

SF 228T

2' x 2' Ceiling Speakers



Extron® Electronics
INTERFACING, SWITCHING AND CONTROL

68-2018-01 Rev. A
05 11

Safety Instructions • English



This symbol is intended to alert the user of important operating and maintenance (servicing) instructions in the literature provided with the equipment.



This symbol is intended to alert the user of the presence of uninsulated dangerous voltage within the product feet enclosure that may present a risk of electric shock.

Caution

Read Instructions • Read and understand all safety and operating instructions before using the equipment.

Retain Instructions • The safety instructions should be kept for future reference.

Follow Warnings • Follow all warnings and instructions marked on the equipment or in the user information.

Avoid Attachments • Do not use tools or attachments that are not recommended by the equipment manufacturer because they may be hazardous.

Consignes de Sécurité • Français



Ce symbole sert à avertir l'utilisateur que la documentation fournie avec le matériel contient des instructions importantes concernant l'exploitation et la maintenance (réparation).



Ce symbole sert à avertir l'utilisateur de la présence dans le boîtier de l'appareil de tensions dangereuses non isolées posant des risques d'électrocution.

Attention

Lire les instructions • Prendre connaissance de toutes les consignes de sécurité et d'exploitation avant d'utiliser le matériel.

Conserver les instructions • Ranger les consignes de sécurité afin de pouvoir les consulter à l'avenir.

Respecter les avertissements • Observer tous les avertissements et consignes marqués sur le matériel ou présentés dans la documentation utilisateur.

Éviter les pièces de fixation • Ne pas utiliser de pièces de fixation ni d'outils non recommandés par le fabricant du matériel car cela risquerait de poser certains dangers.

Sicherheitsanleitungen • Deutsch



Dieses Symbol soll dem Benutzer in der im Lieferumfang enthaltenen Dokumentation besonders wichtige Hinweise zur Bedienung und Wartung (Instandhaltung) geben.



Dieses Symbol soll den Benutzer darauf aufmerksam machen, daß im Inneren des Gehäuses dieses Produktes gefährliche Spannungen, die nicht isoliert sind und die einen elektrischen Schock verursachen können, herrschen.

Achtung

Lesen der Anleitungen • Bevor Sie das Gerät zum ersten Mal verwenden, sollten Sie alle Sicherheits- und Bedienungsanleitungen genau durchlesen und verstehen.

Aufbewahren der Anleitungen • Die Hinweise zur elektrischen Sicherheit des Produktes sollten Sie aufbewahren, damit Sie im Bedarfsfall darauf zurückgreifen können.

Befolgen der Warnhinweise • Befolgen Sie alle Warnhinweise und Anleitungen auf dem Gerät oder in der Benutzerdokumentation.

Keine Zusatzgeräte • Verwenden Sie keine Werkzeuge oder Zusatzgeräte, die nicht ausdrücklich vom Hersteller empfohlen wurden, da diese eine Gefahrenquelle darstellen können.

Instrucciones de seguridad • Español



Este símbolo se utiliza para advertir al usuario sobre instrucciones importantes de operación y mantenimiento (o cambio de partes) que se desean destacar en el contenido de la documentación suministrada con los equipos.



Este símbolo se utiliza para advertir al usuario sobre la presencia de elementos con voltaje peligroso sin protección aislante, que puedan encontrarse dentro de la caja o alojamiento del producto, y que puedan representar riesgo de electrocución.

Precaución

Leer las instrucciones • Leer y analizar todas las instrucciones de operación y seguridad, antes de usar el equipo.

Conservar las instrucciones • Conservar las instrucciones de seguridad para futura consulta.

Obedecer las advertencias • Todas las advertencias e instrucciones marcadas en el equipo o en la documentación del usuario, deben ser obedecidas.

Evitar el uso de accesorios • No usar herramientas o accesorios que no sean específicamente recomendados por el fabricante, ya que podrían implicar riesgos.

安全须知 • 中文



这个符号提示用户该设备用户手册中有重要的操作和维护说明。



这个符号警告用户该设备机壳内有暴露的危险电压，有触电危险。

注意

阅读说明书 • 用户使用该设备前必须阅读并理解所有安全和使用说明。

保存说明书 • 用户应保存安全说明书以备将来使用。

遵守警告 • 用户应遵守产品和用户指南上的所有安全和操作说明。

避免追加 • 不要使用该产品的厂商没有推荐的工具或追加设备，以避免危险。

Warning

Power sources • This equipment should be operated only from the power source indicated on the product. This equipment is intended to be used with a main power system with a grounded (neutral) conductor. The third (grounding) pin is a safety feature, do not attempt to bypass or disable it.

Power disconnection • To remove power from the equipment safely, remove all power cords from the rear of the equipment, or the desktop power module (if detachable), or from the power source receptacle (wall plug).

Power cord protection • Power cords should be routed so that they are not likely to be stepped on or pinched by items placed upon or against them.

Servicing • Refer all servicing to qualified service personnel. There are no user-serviceable parts inside. To prevent the risk of shock, do not attempt to service this equipment yourself because opening or removing covers may expose you to dangerous voltage or other hazards.

Slots and openings • If the equipment has slots or holes in the enclosure, these are provided to prevent overheating of sensitive components inside. These openings must never be blocked by other objects.

Lithium battery • There is a danger of explosion if battery is incorrectly replaced. Replace it only with the same or equivalent type recommended by the manufacturer. Dispose of used batteries according to the manufacturer's instructions.

Avertissement

Alimentations • Ne faire fonctionner ce matériel qu'avec la source d'alimentation indiquée sur l'appareil. Ce matériel doit être utilisé avec une alimentation principale comportant un fil de terre (neutre). Le troisième contact (de mise à la terre) constitue un dispositif de sécurité : n'essayez pas de le contourner ni de le désactiver.

Déconnexion de l'alimentation • Pour mettre le matériel hors tension sans danger, déconnectez tous les cordons d'alimentation de l'arrière de l'appareil ou du module d'alimentation de bureau (s'il est amovible) ou encore de la prise secteur.

Protection du cordon d'alimentation • Acheminer les cordons d'alimentation de manière à ce que personne ne risque de marcher dessus et à ce qu'ils ne soient pas écrasés ou pincés par des objets.

Réparation-maintenance • Faire exécuter toutes les interventions de réparation-maintenance par un technicien qualifié. Aucun des éléments internes ne peut être réparé par l'utilisateur. Afin d'éviter tout danger d'électrocution, l'utilisateur ne doit pas essayer de procéder lui-même à ces opérations car l'ouverture ou le retrait des couvercles risquent de l'exposer à de hautes tensions et autres dangers.

Fentes et orifices • Si le boîtier de l'appareil comporte des fentes ou des orifices, ceux-ci servent à empêcher les composants internes sensibles de surchauffer. Ces ouvertures ne doivent jamais être bloquées par des objets.

Lithium Batterie • Il y a danger d'explosion si la batterie est remplacée de manière incorrecte. Remplacer uniquement avec une batterie du même type ou d'un type équivalent recommandé par le constructeur. Mettre au rebut les batteries usagées conformément aux instructions du fabricant.

Vorsicht

Stromquellen • Dieses Gerät sollte nur über die auf dem Produkt angegebene Stromquelle betrieben werden. Dieses Gerät wurde für eine Verwendung mit einer Hauptstromleitung mit einem geerdeten (neutralen) Leiter konzipiert. Der dritte Kontakt ist für einen Erdschluß, und stellt eine Sicherheitsfunktion dar. Diese sollte nicht umgangen oder außer Betrieb gesetzt werden.

Stromunterbrechung • Um das Gerät auf sichere Weise vom Netz zu trennen, sollten Sie alle Netzkabel aus der Rückseite des Gerätes, aus der externen Stromversorgung (falls dies möglich ist) oder aus der Wandsteckdose ziehen.

Schutz des Netzkabels • Netzkabel sollten stets so verlegt werden, daß sie nicht im Weg liegen und niemand darauf treten kann oder Objekte darauf- oder unmittelbar dagegengestellt werden können.

Wartung • Alle Wartungsmaßnahmen sollten nur von qualifiziertem Servicepersonal durchgeführt werden. Die internen Komponenten des Gerätes sind wartungsfrei. Zur Vermeidung eines elektrischen Schocks versuchen Sie in keinem Fall, dieses Gerät selbst öffnen, da beim Entfernen der Abdeckungen die Gefahr eines elektrischen Schlags und/oder andere Gefahren bestehen.

Schlitze und Öffnungen • Wenn das Gerät Schlitze oder Löcher im Gehäuse aufweist, dienen diese zur Vermeidung einer Überhitzung der empfindlichen Teile im Inneren. Diese Öffnungen dürfen niemals von anderen Objekten blockiert werden.

Lithium-Batterie • Ein Explosionsgefahr, falls die Batterie nicht richtig ersetzt wird. Ersetzen Sie verbrauchte Batterien nur durch den gleichen oder einen vergleichbaren Batterietyp, der auch vom Hersteller empfohlen wird. Entsorgen Sie verbrauchte Batterien bitte gemäß den Herstelleranweisungen.

Advertencia

Alimentación eléctrica • Este equipo debe conectarse únicamente a la fuente/tipo de alimentación eléctrica indicada en el mismo. La alimentación eléctrica de este equipo debe provenir de un sistema de distribución general con conductor neutro a tierra. La tercera pata (puesta a tierra) es una medida de seguridad, no puentearla ni eliminarla.

Desconexión de alimentación eléctrica • Para desconectar con seguridad la acometida de alimentación eléctrica al equipo, desenchufar todos los cables de alimentación en el panel trasero del equipo, o desenchufar el módulo de alimentación (si fuera independiente), o desenchufar el cable del receptáculo de la pared.

Protección del cable de alimentación • Los cables de alimentación eléctrica se deben instalar en lugares donde no sean pisados ni apretados por objetos que se puedan apoyar sobre ellos.

Reparaciones/mantenimiento • Solicitar siempre los servicios técnicos de personal calificado. En el interior no hay partes a las que el usuario deba acceder. Para evitar riesgo de electrocución, no intentar personalmente la reparación/mantenimiento de este equipo, ya que al abrir o extraer las tapas puede quedar expuesto a voltajes peligrosos u otros riesgos.

Ranuras y aberturas • Si el equipo posee ranuras o orificios en su caja/alojamiento, es para evitar el sobrecalentamiento de componentes internos sensibles. Estas aberturas nunca se deben obstruir con otros objetos.

Batería de litio • Existe riesgo de explosión si esta batería se coloca en la posición incorrecta. Cambiar esta batería únicamente con el mismo tipo (o su equivalente) recomendado por el fabricante. Desachar las baterías usadas siguiendo las instrucciones del fabricante.

警告

电源 • 该设备只能使用产品上标明的电源。设备必须使用有地线的供电系统供电。第三条纹（地线）是安全设施，不能不用或跳过。

拔掉电源 • 为安全地从设备拔掉电源，请拔掉所有设备后或桌面电源的电源线，或任何接到市电系统的电源线。

电源线保护 • 妥善布线，避免被踩踏，或重物挤压。

维护 • 所有维修必须由认证的维修人员进行。设备内部没有用户可以更换的零件。为避免出现触电危险不要自己试图打开设备盖子维修该设备。

通风孔 • 有些设备机壳上有通风槽或孔，它们是用来防止机内敏感元件过热。不要使用任何东西挡住通风孔。

锂电池 • 不正确的更换电池会有爆炸的危险。必须使用与厂家推荐的相同或相近型号的电池。按照生产厂家的建议处理废弃电池。

FCC Class A Notice

This equipment has been tested and found to comply with the limits for a Class A digital device, pursuant to part 15 of the FCC Rules. Operation is subject to the following two conditions:

1. This device may not cause harmful interference.
2. This device must accept any interference received, including interference that may cause undesired operation.

The Class A limits are designed to provide reasonable protection against harmful interference when the equipment is operated in a commercial environment. This equipment generates, uses, and can radiate radio frequency energy and, if not installed and used in accordance with the instruction manual, may cause harmful interference to radio communications. Operation of this equipment in a residential area is likely to cause harmful interference, in which case the user will be required to correct the interference at his own expense.

NOTE: This unit was tested with shielded cables on the peripheral devices. Shielded cables must be used with the unit to ensure compliance with FCC emissions limits.

For more information on safety guidelines, regulatory compliances, EMI/EMF compliance, accessibility, and related topics, [click here](#).

Conventions Used in this Guide

In this user guide, the following are used:

NOTE: A note draws attention to important information.

TIP: A tip provides a suggestion to make working with the application easier.

CAUTION: A caution indicates a potential hazard to equipment or data.

WARNING: A warning warns of things or actions that might cause injury, death, or other severe consequences.

Copyright

© 2011 Extron Electronics. All rights reserved.

Trademarks

All trademarks mentioned in this guide are the properties of their respective owners.

Contents

Precautions/Safety Instructions	ii
FCC Information	iii
Copyright, and Trademark Information	iv

Introduction	1
About this User Guide.....	1
Features.....	1
Application Example	2

Installation	3
Installation Considerations	3
Installing the Speakers	3
Speaker Cabling.....	5
70/100 V Audio Distribution System.....	5
Direct 8 ohm Connection to an Amplifier	8
Completing the Installation	9

Specifications, Dimensions and Packaging ...	11
Specifications.....	11
Part Numbers.....	12
Included Parts	12
Optional Parts and Accessories	12
Dimensions	13
Packaging	14

Introduction

About this User Guide

This user guide contains information about the Extron SF 228T 2-way ceiling speakers.

The SF 228T features a low profile design that houses an 8-inch woofer and 1-inch dome tweeter and has the appearance of a standard ventilation grill. All drivers and components above the ceiling are hidden behind the grill.

The SF 228T is designed for use in plenum rated ceiling spaces and can be mounted into a standard 2 feet x 2 feet or 2 feet x 4 feet (with supplied cross bars) false ceiling tile space on a T-bar grid, or, a frame installed in solid ceilings.

Features

- Drop-in 2-way speakers for suspended ceilings.
- UL-2043 plenum rated enclosure.
- An 8-inch, (20.3 cm), full range woofer provides extended low frequency response.
- A 1-inch, (2.5 cm), dome tweeter provides extended high frequency response.
- The white perforated grille matches the appearance of air conditioning vents.
- 8 ohm direct or 70/100 Volt operation with 32, 16, 8, 4, and 2 watt selectable power taps accessed with speaker wiring connections inside the rear panel.
- Frequency response of 50 Hz to 20 kHz.
- 60 watts continuous pink noise, 120 watts continuous program rated.
- 90° conical coverage.
- Low profile enclosure for plenum environments.
- 5 year parts and labor warranty.

Application Example

The following illustration is an application example.

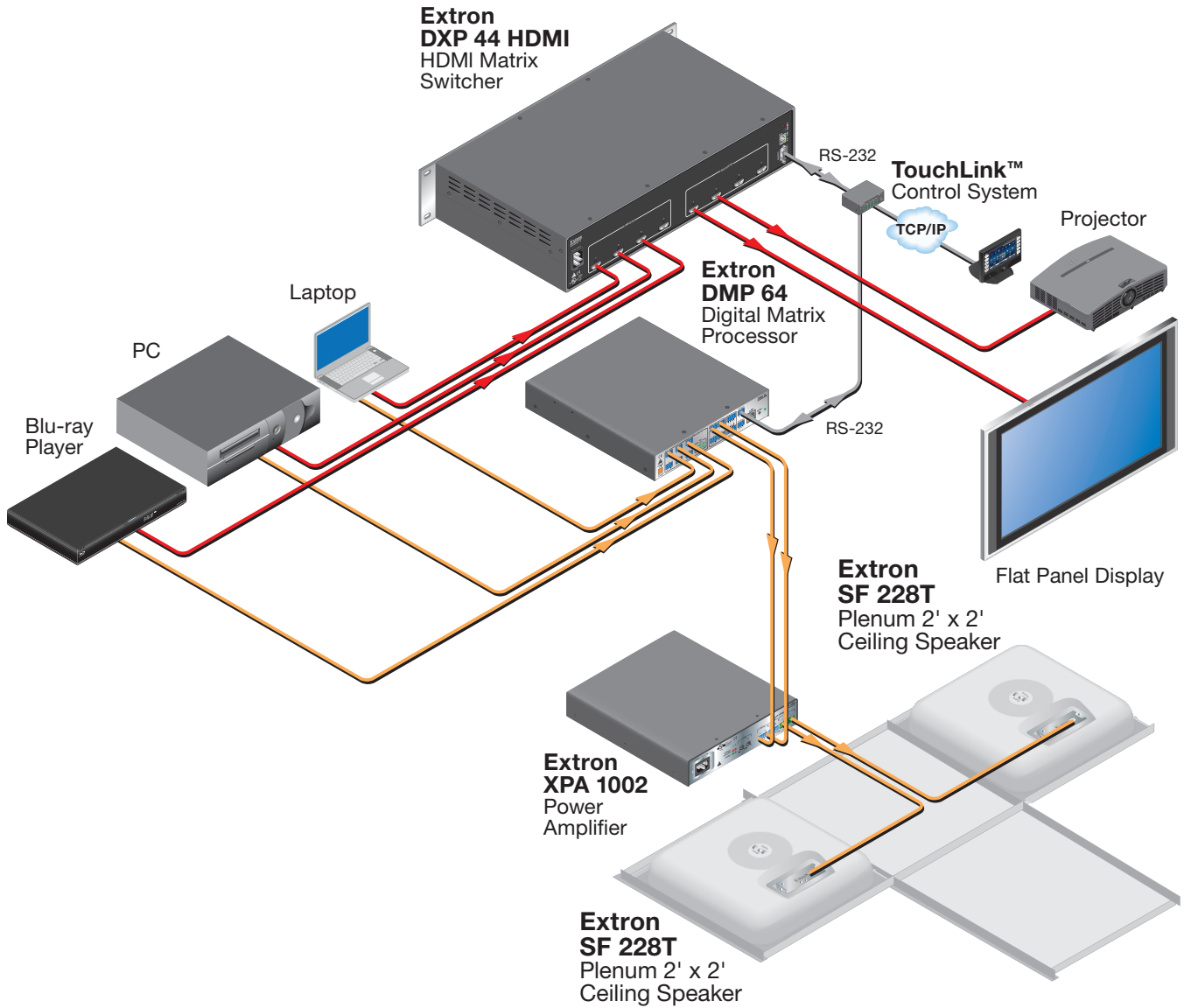

Figure 1. SF 228T Application Example

Installation

This section discusses how to install the SF 228T speaker and includes:

- [Installation Considerations](#)
- [Installing the Speakers](#)
- [Speaker Cabling](#)
- [Completing the Installation](#)

CAUTION: Installation and service must be performed by authorized personnel only.

Installation Considerations

- Installation of conduit and conduit adapters must conform to all applicable building codes and local ordinances.
- Installation in a plenum-rated environment requires a wire gauge of 12 AWG to 18 AWG. Conduit may be required.

NOTE: When daisy chaining speakers in 70 V or 100 V configuration, the maximum wire gauge is 16 AWG.

When daisy chaining speakers in direct (8 ohm) configuration, the maximum wire gauge is 14 AWG.

- If using seismic supports, the installer provides the safety cable.

NOTE: Observe all applicable building codes and local ordinances when installing the speaker.

- Wiring connections depend on the audio system the speakers are being installed with.

Installing the Speakers

1. **Power down** — Power down all attached devices before proceeding.
2. **Remove the suspended ceiling tile** — Remove the ceiling tile where the SF 228T will be installed and lay it aside.

3. **Remove the terminal cover plate** — Loosen (do not remove) the two screws in the keyhole slots on the top terminal cover plate and remove the cover plate as shown below.

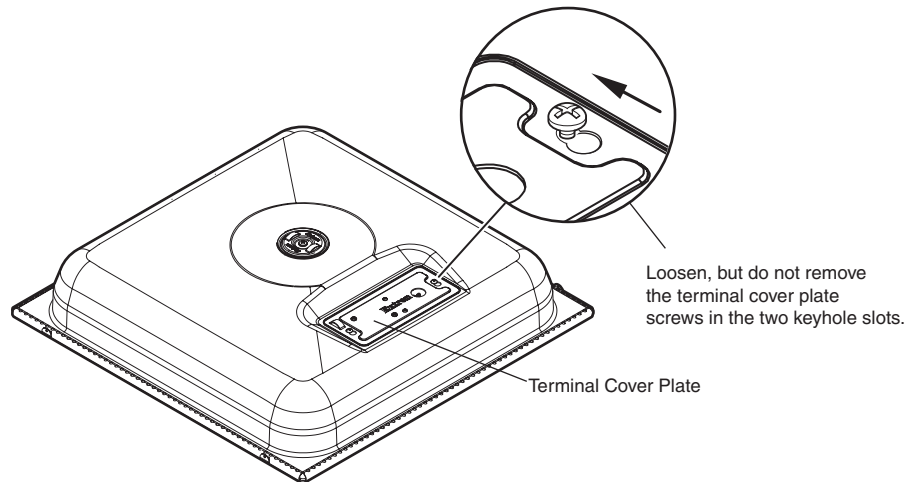

Figure 2. Remove Terminal Cover Plate

4. **Routing cables through the terminal cover plate** — The plate is mounted to the speaker with the transformer side down.
 - a. **When using flexible conduit** — Insert the conduit into the cover plate opening using an appropriate conduit adapter, and secure the conduit to the plate. See below.

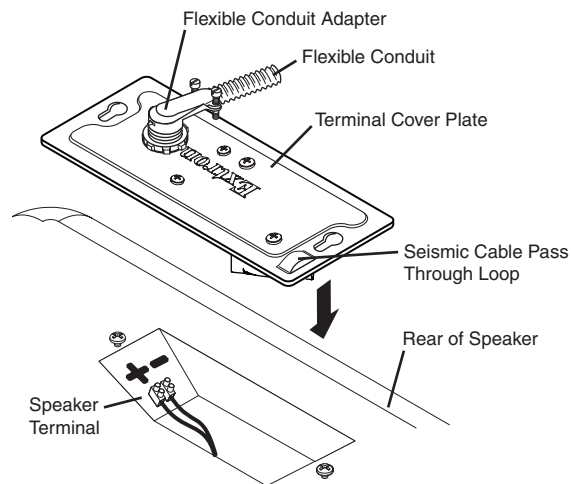

Figure 3. Flexible Conduit Adapter

NOTE: Installation of conduit and conduit adapters should conform to all applicable building codes and local ordinances.

- b. When using speaker wires without conduit** — Secure the cable clamp adapter (included) to the cover plate and insert the wires through the clamp, (see the illustration below).

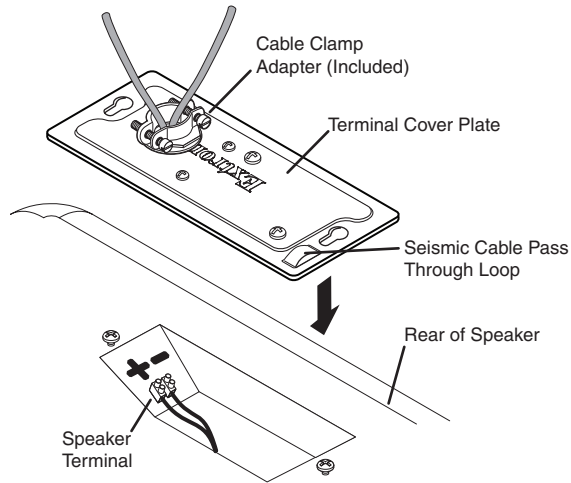

Figure 4. Using a Cable Clamp Adapter

Proceed to **“70/100 V Audio Distribution System”** on page 5 or **“Direct 8 Ohm Connection to an Amplifier”** on page 8 for the appropriate wiring procedure for either a distributed audio system (70V or 100V line distribution through the transformer) or for a direct (8 ohm) connection from an amplifier (bypassing the transformer).

Speaker Cabling

70/100 V Audio Distribution System

NOTE: In the 70V or 100V distribution system diagram below, an optional speaker has been added as an example of daisy chaining SF 228T speakers to a single amplifier output.

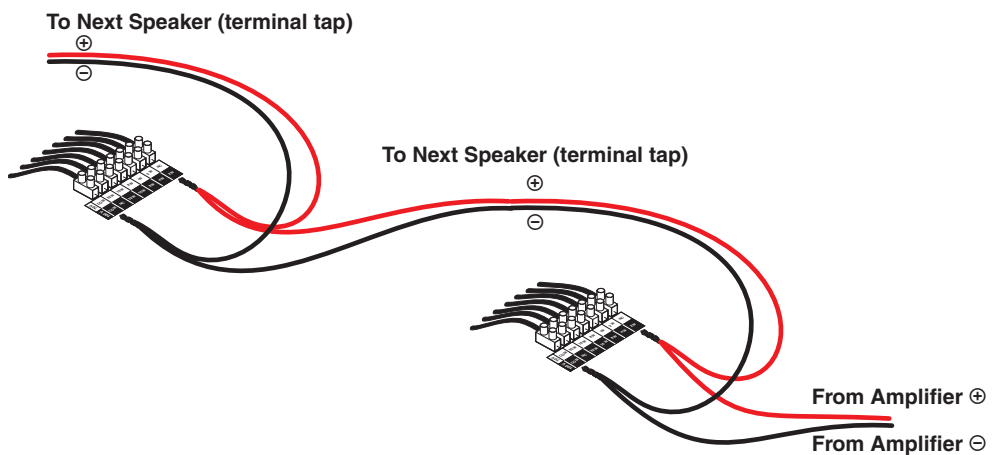

Figure 5. 70/100 V Terminal Connection

1. Flip the terminal cover plate so the transformer side is up.

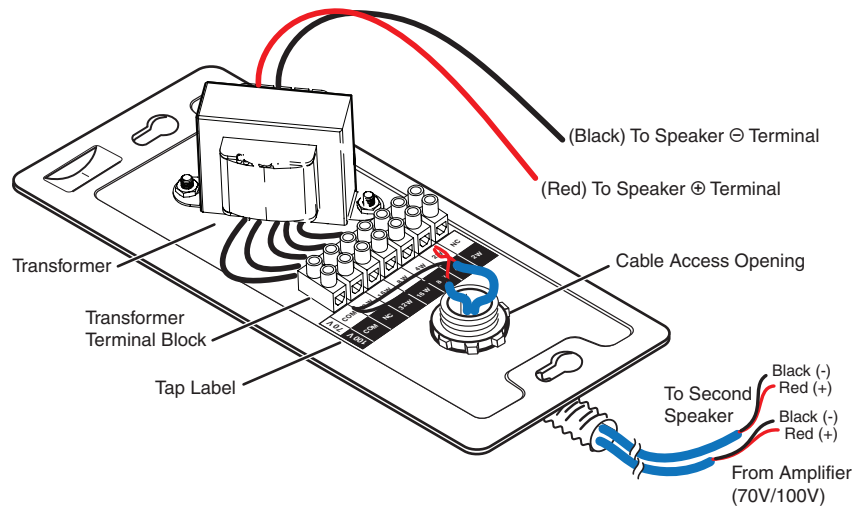

Figure 6. Terminal Cover With Transformer Side Exposed

- a. Route the two wires from the amplifier through the cable access opening to the transformer terminal block. If conduit is used, pull the wires coming from the amplifier through and out of the conduit.
- b. Strip 3/16 inch (5 mm) from the wire ends and keep the wire end strands together by twisting them. Do not tin the wires.
- c. Secure the wires to the appropriate taps on the captive screw connectors of the seven-connector transformer terminal block as indicated on the tap label.

When wiring to a single speaker, the black negative (–) wire attaches to the “COM” terminal, and the red positive (+) wire attaches to the desired terminal tap.

NOTE: Pay close attention to the polarity of the wires. Do not mix negative and positive wires.

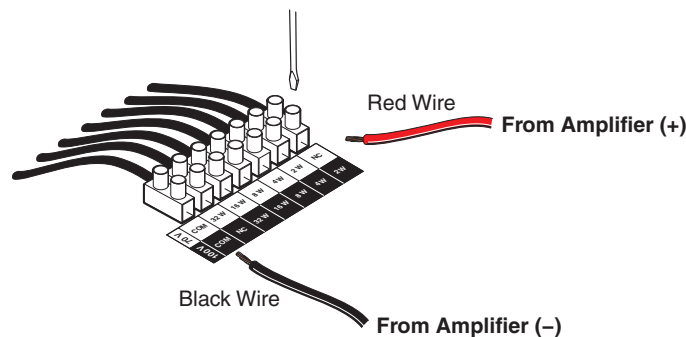

Figure 7. Secure Wiring to Terminal Block

- d. Use a small flat blade screwdriver to tighten the terminal block screws.

- e. To wire additional speakers, route the speaker wires from the second speaker through the cover plate hole to the transformer side. Twist the black negative (–) wires together and the red positive (+) wires together before inserting them into the terminal block. Additional speakers can be daisy-chained this way. See below.

NOTE: Pay close attention to the polarity of the wires. Do not mix negative and positive wires.

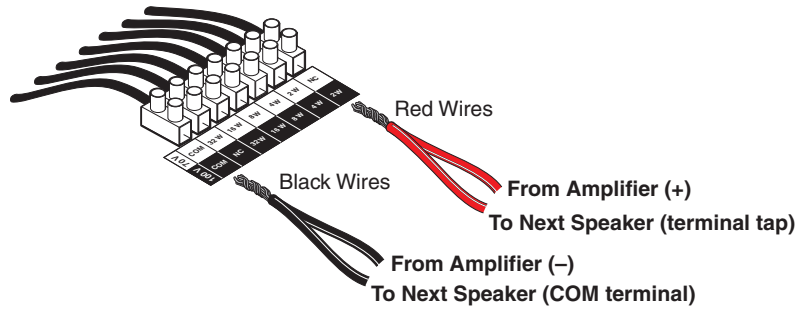

Figure 8. Wiring Additional Speakers

2. Connect wires from the transformer to the speaker.
 - a. Keep the wire strands together by twisting them (do not tin the wires).
 - b. Connect the red positive (+) wire to the + speaker terminal and connect the black negative (–) wire to the – speaker terminal as shown below.

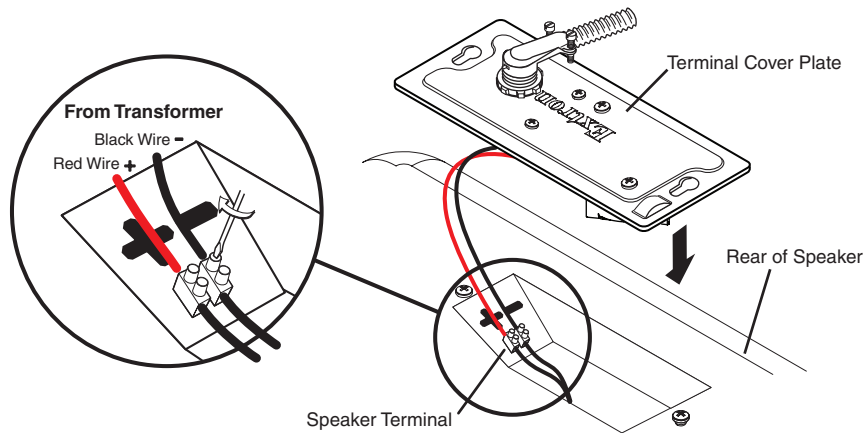

Figure 9. Connect the Speaker Wires

3. Replace the terminal cover plate and tighten the two cover plate screws that were loosened in step 3 of **“Installing the Speakers”** on page 3.
4. Test the system by powering on the amplifier and listening for the correct response from the speakers. Disconnect the power from the amplifier.
5. Proceed to **“Completing the Installation”** on page 8.

Direct 8 Ohm Connection to an Amplifier

1. An amplifier 8 ohm speaker output can be directly connected to the speaker terminal of the SF 228T, (see the diagram below).

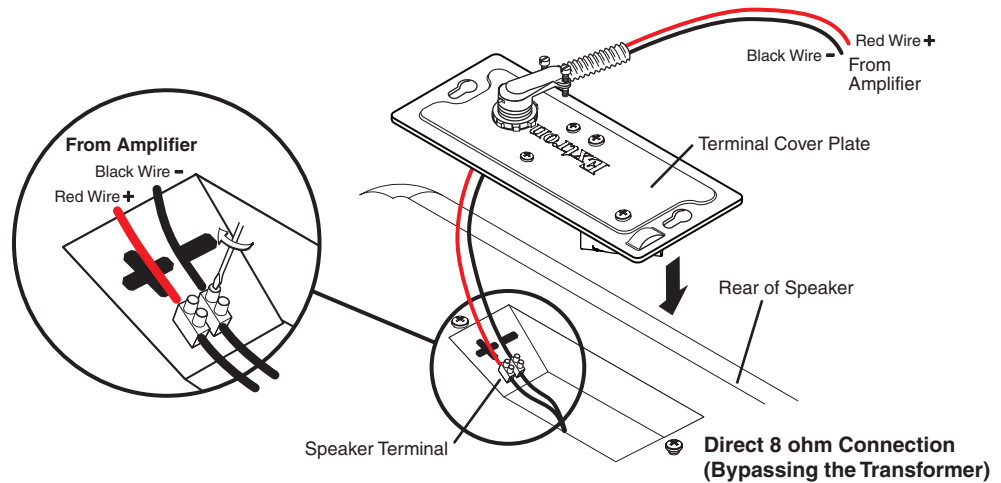

Figure 10. Direct Amplifier Connection to Speaker

2. Route the wires from the amplifier speaker output to the speaker using the same procedure for routing speaker wire (and conduit if applicable) through the terminal cover plate, see ["Installing the Speakers"](#) on page 3.
3. Strip 3/16 inch (5 mm) from the ends of the two speaker wire leads coming from the amplifier. Keep the wire strands together by twisting them (do not tin the wires).
4. Secure the wires to the input terminals of the speaker, observing the correct polarity. Connect the red positive (+) wires to the + speaker terminal and the black negative (-) wires to the - speaker terminal.

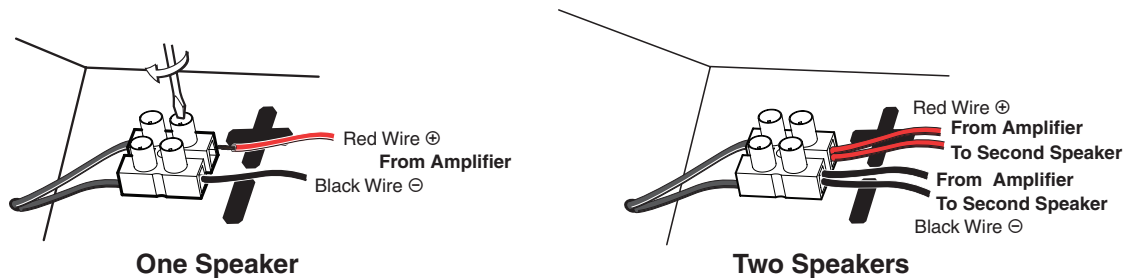

Figure 11. Speaker Terminal Wiring

5. Replace the terminal cover plate and tighten the two cover plate screws that were loosened in step 3 of ["Installing the Speakers"](#) on page 3.
6. Test the system by powering on the amplifier and listening for the correct response from the speakers. Disconnect the power from the amplifier.
7. Proceed to ["Completing the Installation"](#) on page 8.

Completing the Installation

NOTE: Observe all applicable building codes and local ordinances when installing the speaker.

1. For installation in a 2 feet x 2 feet ceiling tile, remove a tile and place the speaker on the existing support rails as shown below.

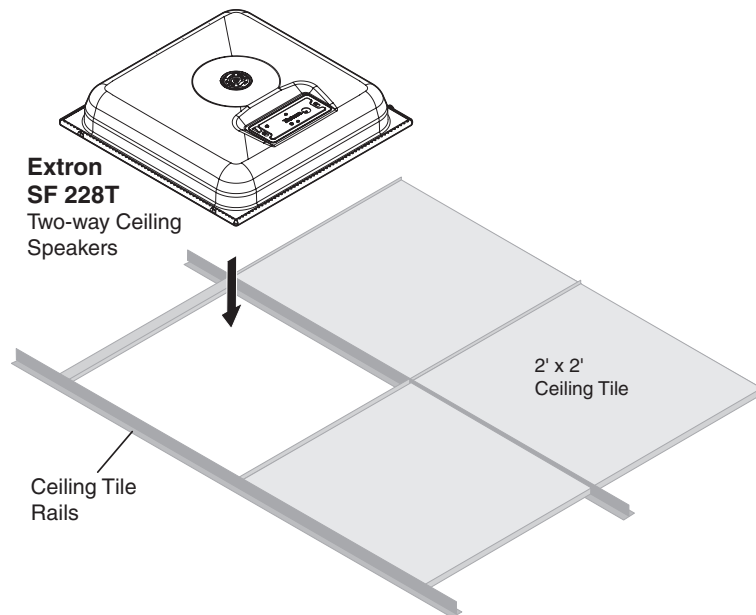

Figure 12. 2 Feet x 2 Feet Ceiling Tile Installation

For installation in a 2 feet x 4 feet ceiling tile, remove a tile and cut the tile in half. Install the supplied T-rail crosspiece, then replace the half-tile as shown below.

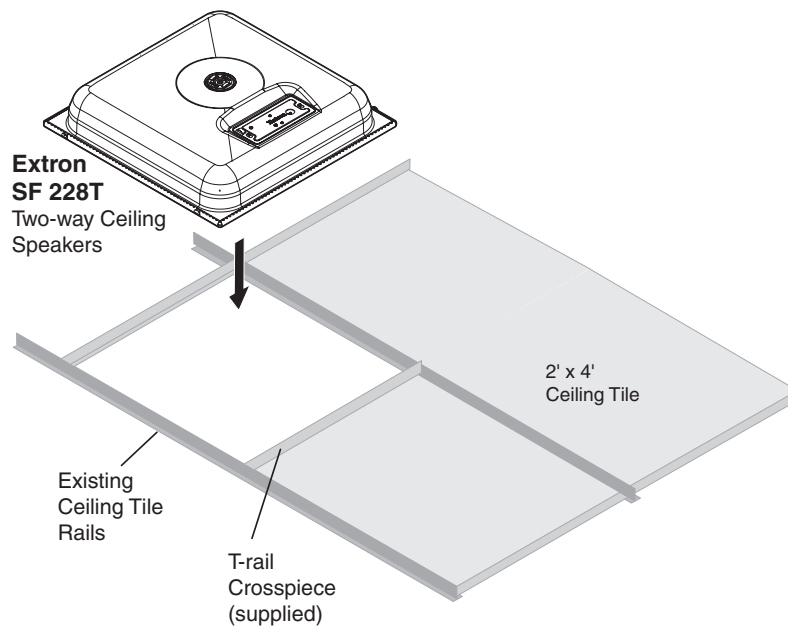
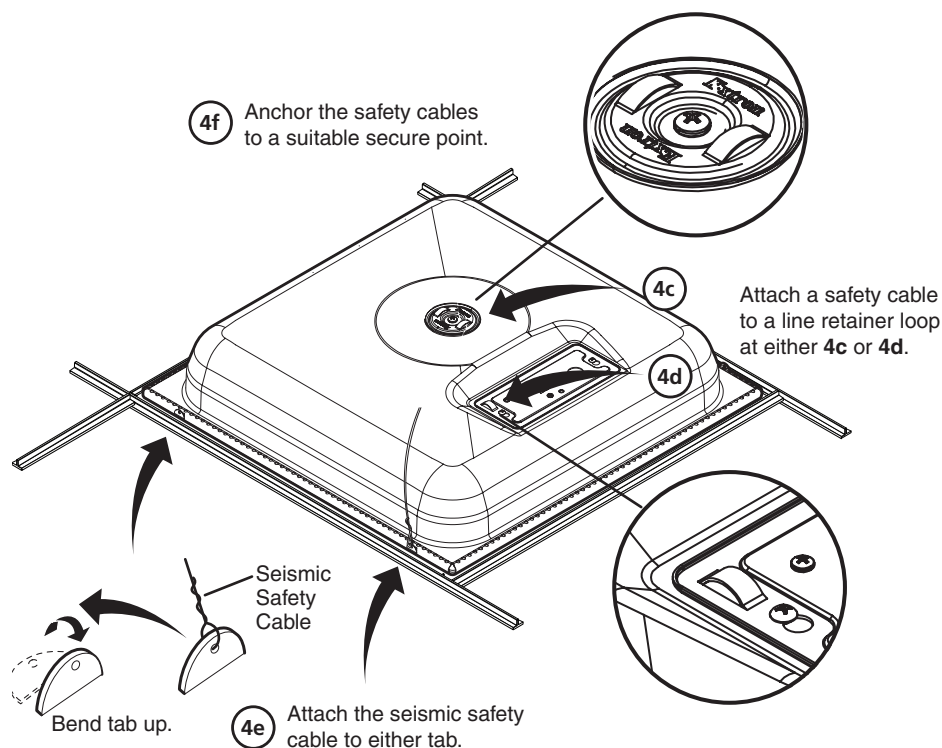

Figure 13. 2 Feet x 4 Feet Ceiling Tile Installation

Set the speaker in place in the ceiling and position it so the speaker edges are hidden by the existing rails or T-rails.

2. If seismic safety lines are being used, install them now. In addition to the tie off at **4c**, Extron recommends tie offs on at least two at the four available tabs at **4e**. See the illustration below.



CAUTION: Repeated bending may cause the tab to break off.

Figure 14. Install the Seismic Safety Lines

- a. Shut off power to all connected equipment.
- b. Temporarily remove a ceiling tile adjacent to the speaker and set it aside.
- c. Attach seismic safety cable to one or both line retainer loops at **4c**.
- d. If a seismic support cable has not been connected at **4c**, attach one at **4d**.

NOTE: A seismic support cable attached at **4c** is recommended. **4d** should be considered only if attaching to **4c** is not possible.

- e. Attach seismic safety cable to at least two of the four seismic bendout tabs located on either side of the speaker.
 - f. Attach the other end of the cables to a sturdy part of the building (studs, roof struts, support girders or similar structure).
 - g. For additional support lines repeat as needed.
 - h. Replace the ceiling tile removed in step **4b**.
3. Power on the amplifier, test and make any source device and system adjustments following the amplifier operating instructions.

Specifications, Dimensions and Packaging

This section discusses the specifications, part number, and packaging for the SF 228T speakers. Topics that are covered, include:

- [Specifications](#)
- [Part Numbers](#)
- [Dimensions](#)
- [Packaging](#)

Specifications

Audio/acoustic and electrical

Speaker type	2-way, full-range, in-ceiling speaker
Frequency range.....	50 Hz to 20 kHz, -10 dB, half space
Power capacity	60 W (rms) continuous pink noise (per IEC 60268-5) 120 W (rms) continuous program
Nominal sensitivity.....	89 dB SPL, 1 watt, 1 m, half space
Nominal coverage angle.....	90° conical coverage
Nominal impedance	8 ohms per speaker
Crossover frequency.....	4.5 kHz
Woofer	(1) 8" (203 mm) polypropylene cone with moisture resistant coating
Tweeter	(1) 1" (25 mm) silk dome
Input connectors	(1) 10 mm Euro-style captive screw terminal block, 7 pole (for transformer input) (1) 10 mm Euro-style captive screw terminal block, 2 pole (for direct 8 ohm input)
Tap settings	
70V input.....	32 W, 16 W, 8 W, 4 W, 2 W, null (bypass 8 ohm direct connection)
100V input.....	Null, 32 W, 16 W, 8 W, 4 W, 2 W (bypass 8 ohm direct connection)

General

Package	2 speakers (1 pair) with 2 feet (61 cm) cross bars
Temperature/humidity	Storage: -40 to +158 °F (-40 to +70 °C) / 10% to 90%, noncondensing Operating: +32 to +122 °F (0 to +50 °C) / 10% to 90%, noncondensing
Mounting.....	Drops into 2 feet x 2 feet (61 cm x 61 cm) or 2 feet x 4 feet (61 cm x 122 cm) suspended tile ceilings
Enclosure type.....	Composite, square, with metal grille
Enclosure outer dimensions.....	5.3" H x 23.75" W x 23.75" L (13.5 cm H x 60.3 cm W x 60.3 cm L)
Product weight.....	Single: 18.5 lbs (8.4 kg)
Shipping weight.....	Pair: 45 lbs (21 kg) with mounting kit

Vibration ISTA 1A in carton (International Safe Transit Association)
Regulatory compliance
 Safety NFPA90A, NFPA70;
 UL Listed for use in plenum airspaces: meets UL 2043 for heat and smoke release,
 meets UL 1480 for commercial and professional audio systems
Warranty 5 years parts and labor

NOTE: All nominal levels are at $\pm 10\%$.

NOTE: Specifications are subject to change without notice.

Part Numbers

Included Parts

Part Description	Part Number
(2) SF 228T Speakers	
(2) Cross bars, (2 feet in length)	
(2) Cable clamp connectors	10-333-02LF
<i>SF 228T Setup Guide</i>	

Optional Parts and Accessories

Part description	Part number
Terminal cover kit with transformer	881285-RK

Dimensions

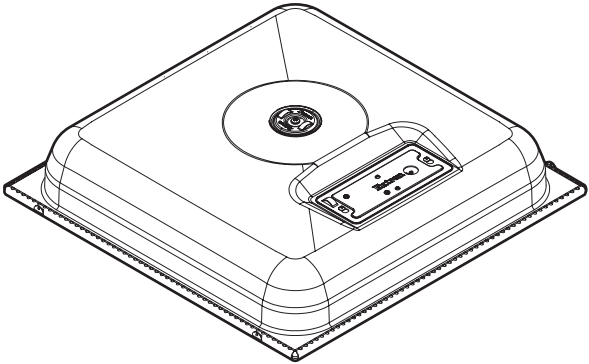
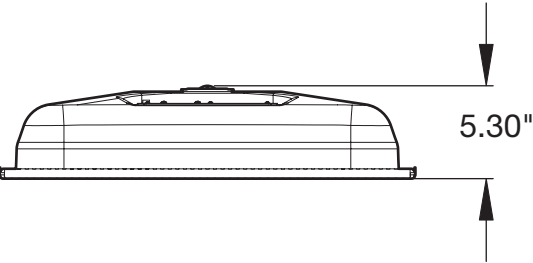
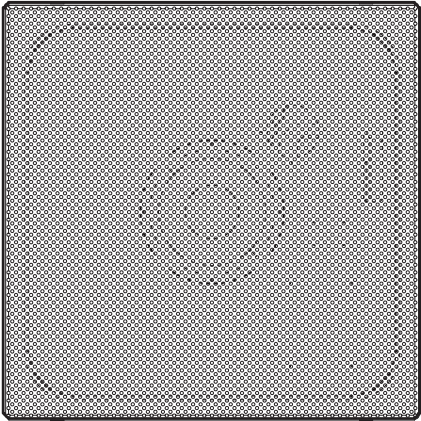
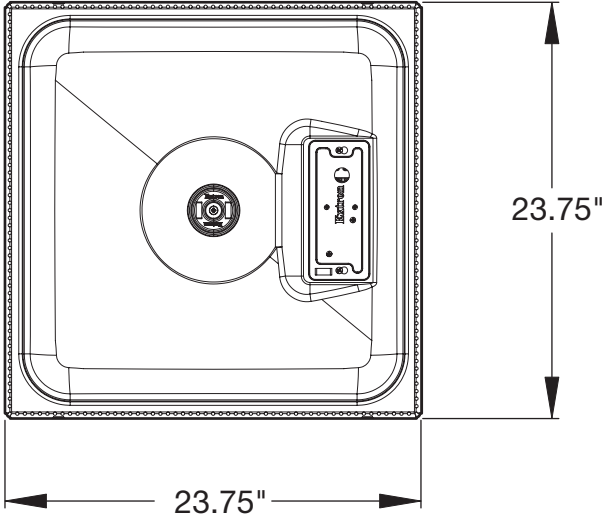

SF 228T

Packaging

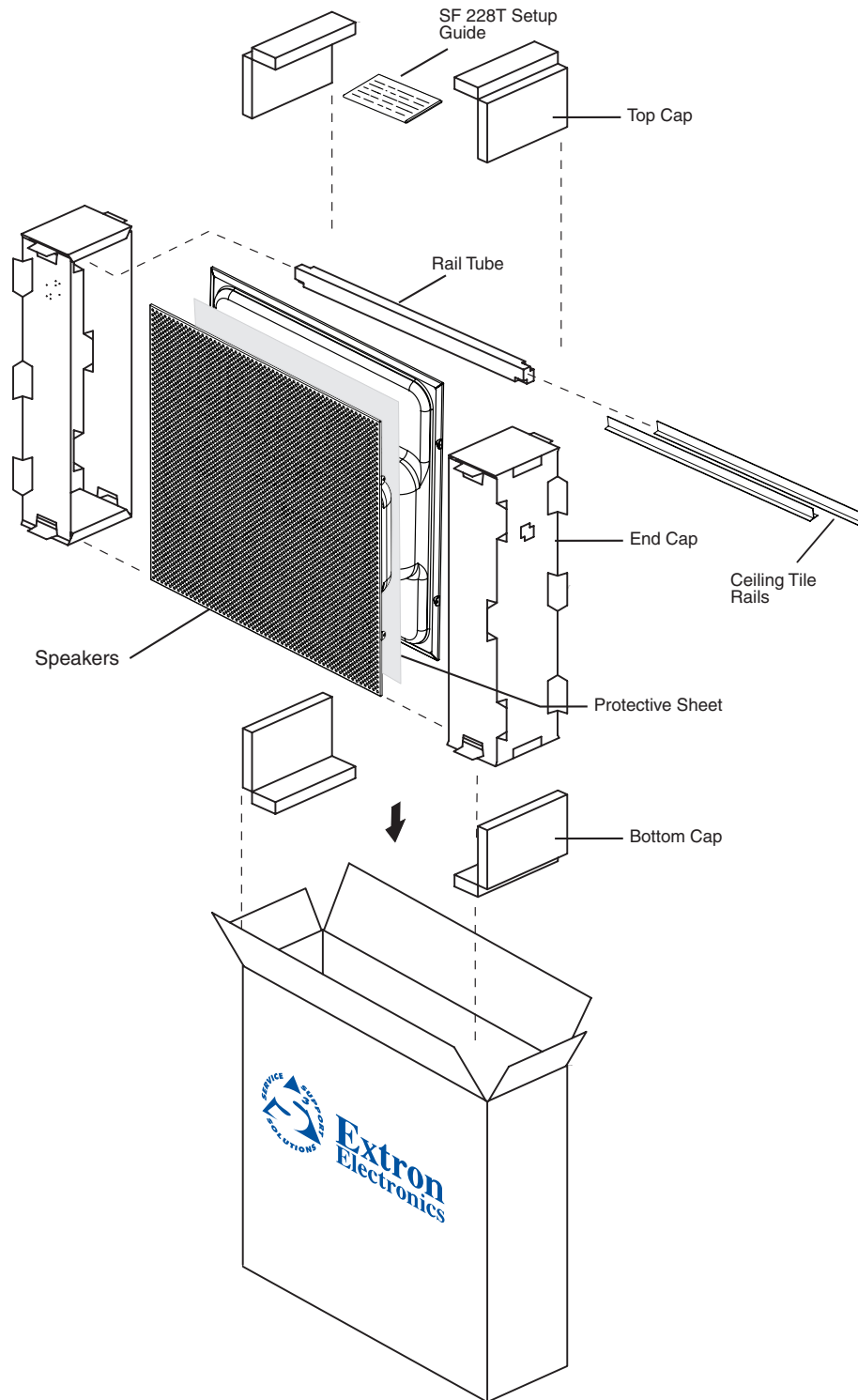

Extron® Warranty

Extron Electronics warrants this product against defects in materials and workmanship for a period of three years from the date of purchase. In the event of malfunction during the warranty period attributable directly to faulty workmanship and/or materials, Extron Electronics will, at its option, repair or replace said products or components, to whatever extent it shall deem necessary to restore said product to proper operating condition, provided that it is returned within the warranty period, with proof of purchase and description of malfunction to:

USA, Canada, South America, and Central America:

Extron Electronics
1001 East Ball Road
Anaheim, CA 92805
U.S.A.

Japan:

Extron Electronics, Japan
Kyodo Building, 16 Ichibancho
Chiyoda-ku, Tokyo 102-0082
Japan

Europe, Africa, and the Middle East:

Extron Europe
Hanzeboulevard 10
3825 PH Amersfoort
The Netherlands

China:

Extron China
686 Ronghua Road
Songjiang District
Shanghai 201611
China

Asia:

Extron Asia
135 Joo Seng Road, #04-01
PM Industrial Bldg.
Singapore 368363
Singapore

Middle East:

Extron Middle East
Dubai Airport Free Zone
F12, PO Box 293666
United Arab Emirates, Dubai

This Limited Warranty does not apply if the fault has been caused by misuse, improper handling care, electrical or mechanical abuse, abnormal operating conditions, or modifications were made to the product that were not authorized by Extron.

NOTE: If a product is defective, please call Extron and ask for an Application Engineer to receive an RA (Return Authorization) number. This will begin the repair process.

USA: (714) 491-1500
Asia: 65.6383.4400

Europe: 31.33.453.4040
Japan: 81.3.3511.7655

Units must be returned insured, with shipping charges prepaid. If not insured, you assume the risk of loss or damage during shipment. Returned units must include the serial number and a description of the problem, as well as the name of the person to contact in case there are any questions.

Extron Electronics makes no further warranties either expressed or implied with respect to the product and its quality, performance, merchantability, or fitness for any particular use. In no event will Extron Electronics be liable for direct, indirect, or consequential damages resulting from any defect in this product even if Extron Electronics has been advised of such damage.

Please note that laws vary from state to state and country to country, and that some provisions of this warranty may not apply to you.

Extron USA - West Headquarters	Extron USA - East	Extron Europe	Extron Asia	Extron Japan	Extron China	Extron Middle East
+800.633.9876 Inside USA/Canada Only	+800.633.9876 Inside USA/Canada Only	+800.3987.6673 Inside Europe Only	+800.7339.8766 Inside Asia Only	+81.3.3511.7655 +81.3.3511.7656 FAX	+400.883.1568 Inside China Only	+971.4.2991800 +971.4.2991880 FAX
+1.714.491.1500 +1.714.491.1517 FAX	+1.919.863.1794 +1.919.863.1797 FAX	+31.33.453.4040 +31.33.453.4050 FAX	+65.6383.4400 +65.6383.4664 FAX		+86.21.3760.1568 +86.21.3760.1566 FAX	

Free Manuals Download Website

<http://myh66.com>

<http://usermanuals.us>

<http://www.somanuals.com>

<http://www.4manuals.cc>

<http://www.manual-lib.com>

<http://www.404manual.com>

<http://www.luxmanual.com>

<http://aubethermostatmanual.com>

Golf course search by state

<http://golfingnear.com>

Email search by domain

<http://emailbydomain.com>

Auto manuals search

<http://auto.somanuals.com>

TV manuals search

<http://tv.somanuals.com>