

User's Manual



PA 300 Peaking Amplifier

68-1108-01 **B**
12 08

Precautions

Safety Instructions • English



This symbol is intended to alert the user of important operating and maintenance (servicing) instructions in the literature provided with the equipment.



This symbol is intended to alert the user of the presence of uninsulated dangerous voltage within the product's enclosure that may present a risk of electric shock.

Caution

Read Instructions • Read and understand all safety and operating instructions before using the equipment.

Retain Instructions • The safety instructions should be kept for future reference.

Follow Warnings • Follow all warnings and instructions marked on the equipment or in the user information.

Avoid Attachments • Do not use tools or attachments that are not recommended by the equipment manufacturer because they may be hazardous.

Consignes de Sécurité • Français



Ce symbole sert à avertir l'utilisateur que la documentation fournie avec le matériel contient des instructions importantes concernant l'exploitation et la maintenance (réparation).



Ce symbole sert à avertir l'utilisateur de la présence dans le boîtier de l'appareil de tensions dangereuses non isolées posant des risques d'électrocution.

Attention

Lire les instructions • Prendre connaissance de toutes les consignes de sécurité et d'exploitation avant d'utiliser le matériel.

Conservier les instructions • Ranger les consignes de sécurité afin de pouvoir les consulter à l'avenir.

Respecter les avertissements • Observer tous les avertissements et consignes marqués sur le matériel ou présents dans la documentation utilisateur.

Éviter les pièces de fixation • Ne pas utiliser de pièces de fixation ni d'outils non recommandés par le fabricant du matériel car cela risquerait de poser certains dangers.

Sicherheitsanleitungen • Deutsch



Dieses Symbol soll dem Benutzer in der im Lieferumfang enthaltenen Dokumentation besonders wichtige Hinweise zur Bedienung und Wartung (Instandhaltung) geben.



Dieses Symbol soll den Benutzer darauf aufmerksam machen, daß im Inneren des Gehäuses dieses Produktes gefährliche Spannungen, die nicht isoliert sind und die einen elektrischen Schock verursachen können, herrschen.

Achtung

Lesen der Anleitungen • Bevor Sie das Gerät zum ersten Mal verwenden, sollten Sie alle Sicherheits- und Bedienungsanleitungen genau durchlesen und verstehen.

Aufbewahren der Anleitungen • Die Hinweise zur elektrischen Sicherheit des Produktes sollten Sie aufbewahren, damit Sie im Bedarfsfall darauf zurückgreifen können.

Befolgen der Warnhinweise • Befolgen Sie alle Warnhinweise und Anleitungen auf dem Gerät oder in der Benutzerdokumentation.

Keine Zusatzgeräte • Verwenden Sie keine Werkzeuge oder Zusatzgeräte, die nicht ausdrücklich vom Hersteller empfohlen wurden, da diese eine Gefahrenquelle darstellen können.

Instrucciones de seguridad • Español



Este símbolo se utiliza para advertir al usuario sobre instrucciones importantes de operación y mantenimiento (o cambio de partes) que se desean destacar en el contenido de la documentación suministrada con los equipos.



Este símbolo se utiliza para advertir al usuario sobre la presencia de elementos con voltaje peligroso sin protección aislante, que puedan encontrarse dentro de la caja o alojamiento del producto, y que puedan representar riesgo de electrocución.

Precación

Leer las instrucciones • Leer y analizar todas las instrucciones de operación y seguridad, antes de usar el equipo.

Conservar las instrucciones • Conservar las instrucciones de seguridad para futura consulta.

Obedecer las advertencias • Todas las advertencias e instrucciones marcadas en el equipo o en la documentación del usuario, deben ser obedecidas.

Evitar el uso de accesorios • No usar herramientas o accesorios que no sean específicamente recomendados por el fabricante, ya que podrían implicar riesgos.

Warning

Power sources • This equipment should be operated only from the power source indicated on the product. This equipment is intended to be used with a main power system with a grounded (neutral) conductor. The third (grounding) pin is a safety feature, do not attempt to bypass or disable it.

Power disconnection • To remove power from the equipment safely, remove all power cords from the rear of the equipment, or the desktop power module (if detachable), or from the power source receptacle (wall plug).

Power cord protection • Power cords should be routed so that they are not likely to be stepped on or pinched by items placed upon or against them.

Servicing • Refer all servicing to qualified service personnel. There are no user-serviceable parts inside. To prevent the risk of shock, do not attempt to service this equipment yourself because opening or removing covers may expose you to dangerous voltage or other hazards.

Slots and openings • If the equipment has slots or holes in the enclosure, these are provided to prevent overheating of sensitive components inside. These openings must never be blocked by other objects.

Lithium battery • There is a danger of explosion if battery is incorrectly replaced. Replace it only with the same or equivalent type recommended by the manufacturer. Dispose of used batteries according to the manufacturer's instructions.

Avvertimento

Alimentazione • Non fare funzionare ce matériel qu'avec la source d'alimentation indiquée sur l'appareil. Ce matériel doit être utilisé avec une alimentation principale comportant un fil de terre (neutre). Le troisième contact (de mise à la terre) constitue un dispositif de sécurité: n'essayez pas de la contourner ni de la désactiver.

Déconnexion de l'alimentation • Pour mettre le matériel hors tension sans danger, déconnectez tous les cordons d'alimentation de l'arrière de l'appareil ou du module d'alimentation de bureau (s'il est amovible) ou encore de la prise secteur.

Protection du cordon d'alimentation • Achémener les cordons d'alimentation de manière à ce que personne ne risque de marcher dessus et à ce qu'ils ne soient pas écrasés ou pincés par des objets.

Réparation-maintenance • Faire exécuter toutes les interventions de réparation-maintenance par un technicien qualifié. Aucun des éléments internes ne peut être réparé par l'utilisateur. Afin d'éviter tout danger d'électrocution, l'utilisateur ne doit pas essayer de procéder lui-même à ces opérations car l'ouverture ou le retrait des couvercles risquent de l'exposer à de hautes tensions et autres dangers.

Fentes et orifices • Si le boîtier de l'appareil comporte des fentes ou des orifices, ceci sert à empêcher les composants internes sensibles de surchauffer. Ces ouvertures ne doivent jamais être bloquées par des objets.

Lithium Batterie • Il a danger d'explosion s'il y a un remplacement incorrect de la batterie. Remplacer uniquement avec une batterie du même type ou d'un équivalent recommandé par le constructeur. Mettre au rebut les batteries usagées conformément aux instructions du fabricant.

Vorsicht

Stromquellen • Dieses Gerät sollte nur über die auf dem Produkt angegebene Stromquelle betrieben werden. Dieses Gerät wurde für eine Verwendung mit einer Hauptstromleitung mit einem geerdeten (neutralen) Leiter konzipiert. Der dritte Kontakt ist für einen Erdschluß, und stellt eine Sicherheitsfunktion dar. Diese sollte nicht umgangen oder außer Betrieb gesetzt werden.

Stromunterbrechung • Um das Gerät auf sichere Weise vom Netz zu trennen, sollten Sie alle Netzkabel aus der Rückseite des Gerätes, aus der externen Stromversorgung (falls dies möglich ist) oder aus der Wandsteckdose ziehen.

Schutz des Netzkabels • Netzkabel sollten stets so verlegt werden, daß sie nicht im Weg liegen und niemand darauf treten kann oder unmittelbar dagegen gestellt werden können.

Wartung • Alle Wartungsmaßnahmen sollten nur von qualifiziertem Servicepersonal durchgeführt werden. Die internen Komponenten des Gerätes sind wartungsfrei. Zur Vermeidung eines elektrischen Schocks versuchen Sie in keinem Fall, dieses Gerät selbst öffnen, da beim Entfernen der Abdeckungen die Gefahr eines elektrischen Schlags und/oder anderer Gefahren bestehen.

Schlitze und Öffnungen • Wenn das Gerät Schlitze oder Löcher im Gehäuse aufweist, dienen diese zur Vermeidung einer Überhitzung der empfindlichen Teile im Inneren. Diese Öffnungen dürfen niemals von anderen Objekten blockiert werden.

Lithium-Batterie • Explosionsgefahr, falls die Batterie nicht richtig ersetzt wird. Ersetzen Sie verbrauchte Batterien nur durch den gleichen oder einen vergleichbaren Batterietyp, der auch vom Hersteller empfohlen wird. Entsorgen Sie verbrauchte Batterien bitte gemäß den Herstelleranweisungen.

Advertencia

Alimentación eléctrica • Este equipo debe conectarse únicamente a la fuente/tipo de alimentación eléctrica indicada en el mismo. La alimentación eléctrica de este equipo debe provenir de un sistema de distribución general con conductor neutro a tierra. La tercera pata (puesta a tierra) es una medida de seguridad, no puentearla ni eliminarla.

Desconexión de alimentación eléctrica • Para desconectar con seguridad la conectada de alimentación eléctrica al equipo, desenchufar todos los cables de alimentación en el panel trasero del equipo, o desenchufar el módulo de alimentación (si fuera independiente), o desenchufar el cable del receptáculo de la pared.

Protección del cables de alimentación • Los cables de alimentación eléctrica se deben instalar en lugares donde no sean pisados ni apretados por objetos que se puedan apoyar sobre ellos.

Reparaciones/mantenimiento • Solicitar siempre los servicios técnicos de personal calificado. En el interior no hay partes a las que el usuario debe acceder. Para evitar riesgo de electrocución, no intentar personalmente la reparación/mantenimiento de este equipo, ya que al abrir o extraer las tapas puede quedar expuesto a voltajes peligrosos u otros riesgos.

Ranuras y aberturas • Si el equipo posee ranuras o orificios en su caja/alojamiento, es para evitar el sobrecalentamiento de componentes internos sensibles. Estas aberturas nunca se deben obstruir con otros objetos.

Batería de litio • Existe riesgo de explosión si esta batería se coloca en la posición incorrecta. Cambiar esta batería únicamente con el mismo tipo (o su equivalente) recomendado por el fabricante. Desachar las baterías usadas siguiendo las instrucciones del fabricante.

安全须知 • 中文



这个符号提示用户该设备用户手册中有重要的操作和维护说明。



这个符号警告用户该设备机壳内有暴露的危险电压，有触电危险。

注意

阅读说明书 • 用户使用该设备前必须阅读并理解所有安全和使用说明。

保存说明书 • 用户应保存安全说明书以备将来使用。

遵守警告 • 用户应遵守产品和用户指南上的所有安全和操作说明。

避免追加 • 不要使用该产品厂商没有推荐的工具或追加设备，以避免危险。

警告

电源 • 该设备只能使用产品上标明的电源。设备必须使用有地线的供电系统供电。第三条线（地线）是安全设施，不能不用或跳过。

拔掉电源 • 为安全地从设备拔掉电源，请拔掉所有设备后或桌面电源的电源线，或任何接到市电系统的电源线。

电源线保护 • 妥善布线，避免被踩踏，或重物挤压。

维护 • 所有维修必须由认证的维修人员进行。设备内部没有用户可以更换的零件。为避免出现触电危险不要自己试图打开设备盖子维修该设备。

通风孔 • 有些设备机壳上有通风槽或孔，它们是用来防止机内敏感元件过热。不要用任何东西挡住通风孔。

锂电池 • 不正确的更换电池会有爆炸的危险。必须使用与厂家推荐的相同或相近型号的电池。按照生产厂的建议处理废弃电池。

FCC Class A Notice

This equipment has been tested and found to comply with the limits for a Class A digital device, pursuant to part 15 of the FCC Rules. Operation is subject to the following two conditions: (1) this device may not cause harmful interference, and (2) this device must accept any interference received, including interference that may cause undesired operation. The Class A limits are designed to provide reasonable protection against harmful interference when the equipment is operated in a commercial environment. This equipment generates, uses, and can radiate radio frequency energy and, if not installed and used in accordance with the instruction manual, may cause harmful interference to radio communications. Operation of this equipment in a residential area is likely to cause harmful interference, in which case the user will be required to correct the interference at his own expense.

NOTE

This unit was tested with shielded cables on the peripheral devices. Shielded cables must be used with the unit to ensure compliance with FCC emissions limits.



Table of Contents

Chapter One • Introduction	1-1
About this Manual	1-2
About the PA 300.....	1-2
Features	1-2
Chapter Two • Installation and Operation	2-1
Installation Overview.....	2-2
Mounting the PA 300	2-2
Tabletop use	2-3
Rack mounting	2-3
Under-desk mounting.....	2-4
Through-desk mounting.....	2-6
Front Panel Features.....	2-7
Rear Panel Features.....	2-7
Cabling	2-8
Chapter Three • Adjusting the Display	3-1
Signal Compatibility	3-2
Potentiometer Adjustments.....	3-2
Adjusting gain with an oscilloscope.....	3-2
Adjusting gain without an oscilloscope.....	3-2
Adjusting the peaking	3-3
Appendix A • Specifications, Part Numbers, and Accessories	A-1
Specifications	A-2
Parts	A-5
Included parts.....	A-5
Optional accessories	A-5
Cables.....	A-5

Table of Contents, cont'd

All trademarks mentioned in this manual are the properties of their respective owners.

68-1108-01 B
12 08



PA 300

1

Chapter One

Introduction

About this Manual

About the PA 300

Features

Introduction

About this Manual

This manual contains information about the Extron PA 300 peaking amplifier, and includes information on how to install, operate and troubleshoot the unit.

About the PA 300

The PA 300 is an ultra high performance RGB peaking amplifier capable of driving a 1600 x 1200 resolution computer signal over 600 feet (185 m) using Extron Mini HR cables, or 1000 feet (300 m) using Extron RG6 cable. The PA 300 is compatible with both RGB and HDTV component signals.

The PA 300 has one gain potentiometer and two peaking potentiometers on the front panel. On the rear panel, the PA 300 provides five BNCs for RGBHV input and five BNCs for RGBHV output. The unit restores the sync signals, but does not process them for format, polarity, or delay.

The PA 300 is housed in a 1U, half rack, 6" (15.2 cm) deep, 2-piece enclosure, and uses an internal power supply.

Features

Bandwidth — 350 MHz (-3 dB) RGB video bandwidth, fully loaded.

Gain and peaking control — allows optimized output compensation for various cable lengths and applications.

Light and compact metal enclosure — 1U, half rack, 6" (15.2 cm) deep, 2-piece enclosure.

Versatile mounting options — can be set on a table; mounted on a rack shelf; or mounted through or under a desk, podium, or tabletop.

Global accessibility — has a universal internal power supply that allows for worldwide usability.



PA 300

2 Chapter Two

Installation and Operation

Installation Overview

Mounting the PA 300

Front Panel Features

Rear Panel Features

Cabling

Installation and Operation

Installation Overview

- 1 Be certain the source device, the PA 300, and the output device are turned off and disconnected from the power source.
- 2 If desired, mount the PA 300 in a rack or furniture. See "Mounting the PA 300", below.
- 3 Cable the inputs and outputs to the PA 300. See "Cabling" on page 2-8.
- 4 Plug the input device, the PA 300, and the output device into a grounded AC source.
- 5 Turn on the input and output devices.

Mounting the PA 300

The PA 300 peaking amplifier can be set on a table; mounted on a rack shelf; or mounted through or under a desk, podium, or tabletop.

The following kits are available for mounting the PA 300:

- RSB 129 1U, 9.5" deep basic rack shelf (part #60-604-01)
- RSU 129 1U, 9.5" deep universal rack shelf kit (part #60-190-01)
- RSB 126 1U, 6" deep basic rack shelf (part #60-604-10)
- RSU 126 1U, 6" deep universal rack shelf kit (part #60-190-10)
- MBU 125 Under-desk mounting kit (part #70-077-01)
- MBD 129 Through-desk mounting kit (part #70-077-02)

The following sections provide instructions for these options.

Tabletop use

Four self-adhesive rubber feet are included with the PA 300. For tabletop use, affix one foot at each corner of the bottom side of the unit and place the unit in the desired location.

Rack mounting

For optional rack mounting, do not install the rubber feet. Mount the PA 300 on a 6" deep, 1U high rack shelf (part #60-190-10 or 60-604-10) or a 9.5" deep 1U high rack shelf (part #60-190-01 or 60-604-01).

1. Remove the rubber feet if they were previously installed on the bottom of the unit.
2. Mount the unit on the rack shelf, using two 4-40 x 3/16" screws in opposite (diagonal) corners to secure it.
3. Install blank panel(s) or other unit(s) on the rack shelf.
4. Attach the rack shelf to the rack using the supplied bolts.

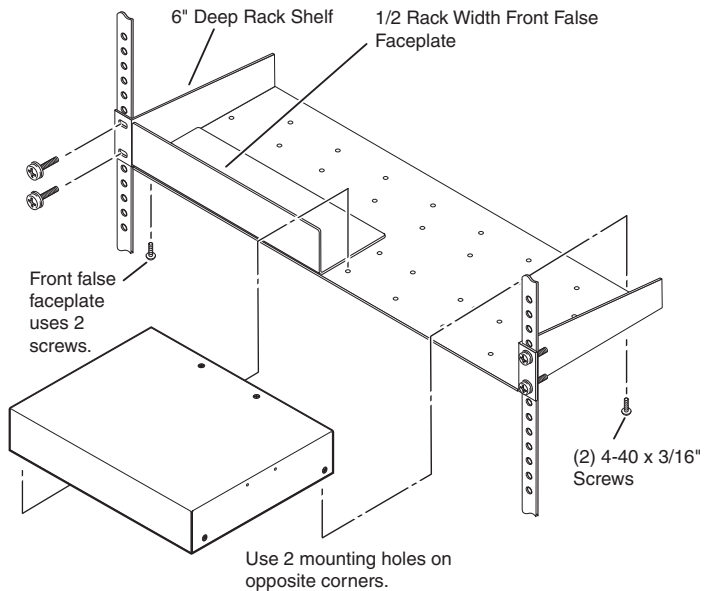

Mounting the PA 300 on a 6-inch deep rack shelf

Installation and Operation, cont'd

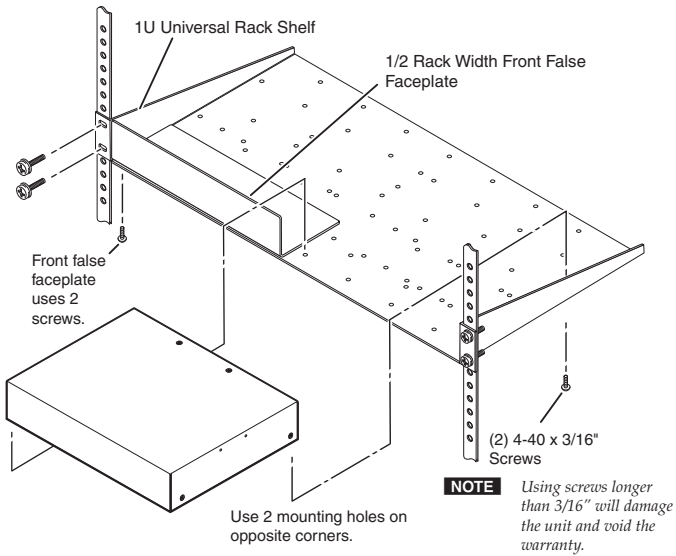

Mounting the PA 300 on a 9.5" deep rack shelf

Under-desk mounting

Furniture-mount (under a desk or shelf) the PA 300 using the optional mounting kit (part #70-077-01), as illustrated below.

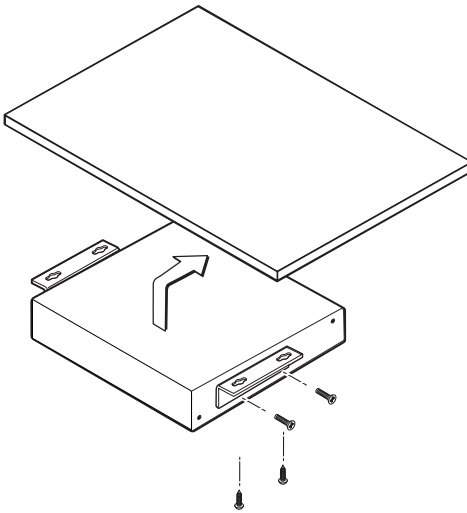

Under-desk mounting the PA 300

-
1. Remove two screws from one side of the unit. Retain the screws for possible future use.
 2. Attach one bracket to the side of the unit, using the provided machine screws.
 3. Repeat steps 1 and 2 on the other side of the unit.
 4. Hold the PA 300 with the attached brackets against the mounting location. On the mounting surface, mark the location of the four bracket screw holes.
 5. Drill pilot holes 1/4" (6.4 mm) deep and 3/32" (2.4 mm) in diameter in the desk or table at the locations of the mounting bracket screws. The holes should be drilled from the underside or inside (concealed side) of the furniture, where the amplifier will be located.
 6. Insert #8 wood screws into the four pilot holes. Tighten each screw into the mounting surface until slightly less than 1/4" of the screw head protrudes.
 7. Align the mounting screws with the slots in the brackets and place the unit against the surface, with the screws through the bracket slots.
 8. Slide the unit slightly forward or back, then tighten all four screws to secure it in place.

Installation and Operation, cont'd

Through-desk mounting

Mount the PA 300 through a desk or table, using the optional mounting kit (part #70-077-02), as illustrated below.

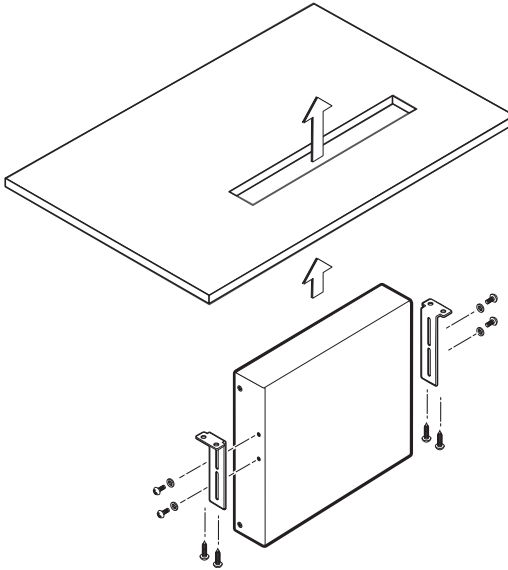

Through-desk mounting the PA 300

1. Install the brackets as shown above. Tighten the screws only enough to allow sliding of the brackets.
2. Mark the opening through which the unit will be mounted — approximately 1.8" by 8.9" (4.6 cm by 22.6 cm).
3. Cut out the material from the installation area.
4. Hold the unit, with the mounting brackets attached, under the furniture where it will be secured. Mark where the screws will attach the mounting bracket to the underside of the furniture.
5. Drill pilot holes 1/4" (6.4 mm) deep and 3/32" (2.4 mm) in diameter in the desk or table at the locations marked in step 4.
6. Using the four provided wood screws, attach the brackets to the mounting surface.
7. Slide the unit up and down or back and forth in the mounting brackets until the face of the PA 300 is at the desired height. Tighten the screws that secure the brackets to the unit.

Front Panel Features

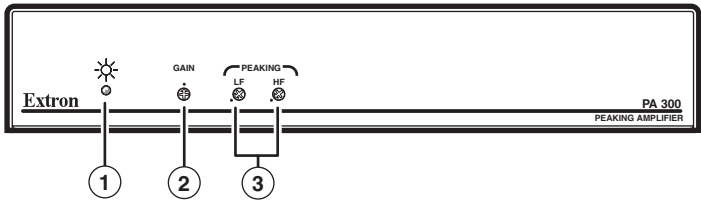

- ① **Power LED** — Lights when the PA 300 is receiving power.
- ② **Gain control potentiometer** — Adjusts the amount of compensation for amplitude losses caused by cable resistance.
- ③ **Peaking control potentiometers** — provide optimum signal compensation. Separate high and low frequency controls.
LF — Provides adjustment to minimize image streaking.
HF — Provides adjustment for achieving the best image detail.

Rear Panel Features

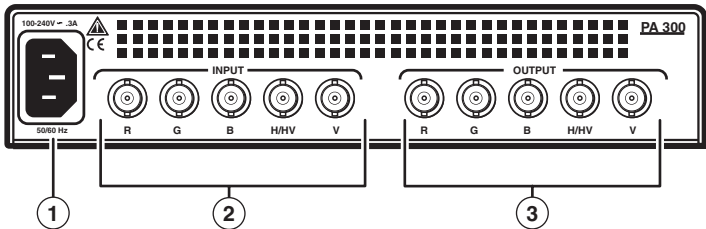

- ① **AC power input connector** — Attach a standard IEC power cord (100 VAC to 240 VAC, 50 or 60 Hz).
- ② **Input BNC connectors** — Connect to the input device.
- ③ **Output BNC connectors** — Connect to the output device.

Installation and Operation, cont'd

Cabling

The PA 300 is specifically designed for long cable run applications. For best results, install the amplifier close to the signal source to drive a long cable to the display.

The inputs of the PA 300 are BNC connectors. If the signal source uses a 15-pin HD connector, use an Extron SYM BNCM cable (Extron part #26-533-xx) to make the connection. See the illustration below.

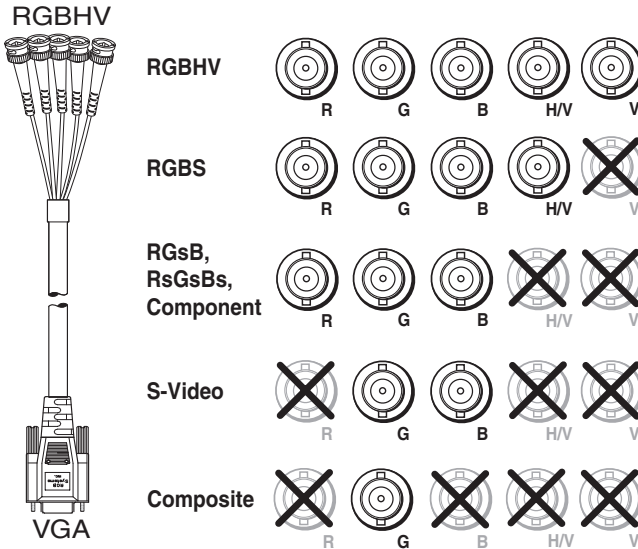

NOTE For component and S-video connections G is luma (Y)

To make input and output connections to other devices, do the following:

1. Turn off the PC and the local monitor.
2. Connect the output of the RGB source to the PA 300 input.
3. Connect the PA 300 output to the RGB display device.
4. Turn on the source and display devices, then the PA 300.
5. Adjust the front panel potentiometers to achieve the optimal image quality for your display. See chapter 3, "Adjusting the Display", for detailed instructions.



PA 300

3

Chapter Three

Adjusting the Display

Signal Compatibility

Potentiometer Adjustments

Adjusting the Display

Signal Compatibility

The PA 300 processes VGA-UXGA, RGBHV, RGBS, RGBsB, RsGsBs, HDTV, and component video signals.

Potentiometer Adjustments

The PA 300 achieves superior amplification by using two independent peaking potentiometers: LF for streaking adjustment and HF for detail adjustment.

The goal in adjusting the PA 300 Gain and Peaking potentiometers is to produce a sharp image (i.e., an image free of streaking or smearing) on the attached display.

An oscilloscope is required for the most accurate gain adjustment, but gain can also be adjusted by observation. The following instructions explain how to adjust the gain with and without the use of an oscilloscope. An oscilloscope is not necessary for the peaking adjustment.

Adjusting gain with an oscilloscope

To adjust the Gain potentiometer using an oscilloscope:

1. Remove the cable from the source and attach a VTG 300 test generator to this cable.
2. Use the White Field test pattern for the VTG 300 setting.
3. Remove the far end of the cable from the projector and attach the oscilloscope using 75 ohm termination.
4. Use an Extron Tweaker to adjust the Gain potentiometer for a 0.7 V_{p-p} reading from white (top) to black (bottom) of the waveform.
5. Once gain is successfully adjusted, replace the source and display cables.
6. See "Adjusting the peaking" on the following page.

Adjusting gain without an oscilloscope

Use an Extron Tweaker to turn the Gain potentiometer until the image reaches the desired level of brightness.

Adjusting the peaking

To adjust the Peaking potentiometers, do the following:

1. Using MS Paint and a spreadsheet, create a testing image on your PC desktop that includes squares, lines, text, and gradations of color. Use the illustration below as a guide.

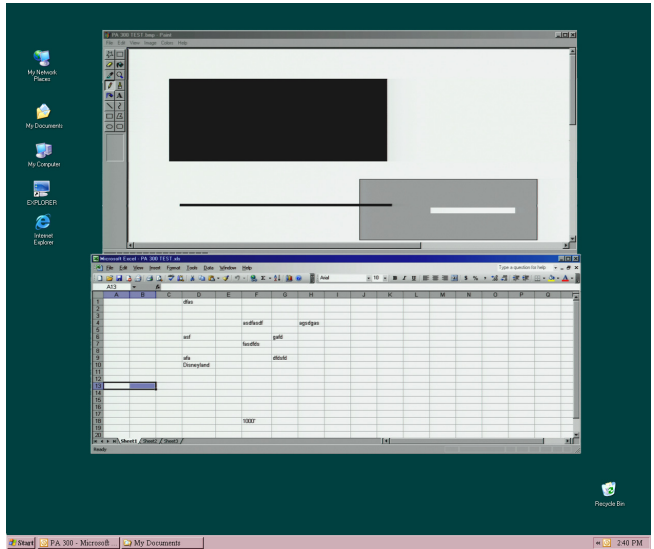

2. Adjust the LF (low frequency) potentiometer until the image is free of streaking. When the LF is over adjusted, the streaking is the same color as the image, as shown below.

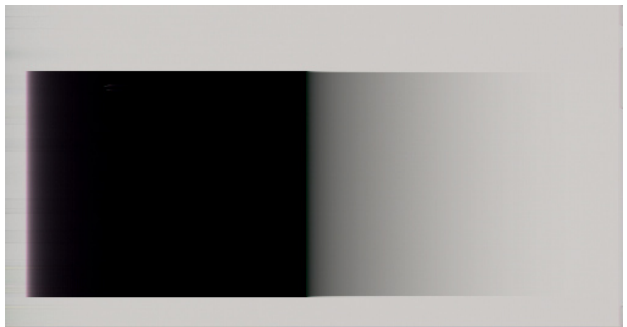

Adjusting the Display, cont'd

When the LF is under adjusted, the streaking is the inverse color of the image, as shown below.



The potentiometer should be adjusted midway between these two extremes.

3. Adjust the HF potentiometer until both text and icon images appear sharp. When HF is over adjusted, ghosting may appear, as illustrated below.



When the HF is under adjusted, smearing may appear, as shown below.



The potentiometer should be adjusted midway between these two extremes.

4. Alternate between adjusting the HF and LF potentiometers until the display shows a clear and sharp image.



PA 300

A

Appendix A

Specifications, Part Numbers, and Accessories

Specifications

Parts

Specifications, Part Numbers, and Accessories

Specifications

Video

Gain	-2.5 to +3.5 dB (x0.75 to x1.4), adjustable; default = 0 dB
Peaking/equalization	
Low frequency	0 to 4 dB at 10 MHz, adjustable
High frequency	0 to 15 dB at 120 MHz, adjustable
Bandwidth	350 MHz (-3 dB)
Output cable driving distance.....	Up to 600' (185 m) with Extron Mini HR cable. Up to 1000' (300 m) with Extron RG6 or RG 59 cable (tested with a 1600x1200, 60 Hz computer video signal)

Video input

Number/signal type	1 analog RGBHV, RGBS, RGsB, RsGsBs, component video (interlaced, progressive, HDTV), S-video, composite video
Connectors	5 BNC female
Nominal level	1.0 Vp-p for Y of component video and S-video and for composite video 0.7 Vp-p for RGB (excluding sync) and for R-Y and B-Y of component video 0.3 Vp-p for C of S-video
Minimum/maximum levels.....	Analog: 0.4 V to 2.0 Vp-p with no offset at unity gain
Impedance.....	75 ohms
Horizontal frequency.....	15 kHz to 150 kHz
Vertical frequency.....	40 Hz to 140 Hz
Return loss	-30 dB @ 0 to 5 MHz
DC offset (max. allowable).....	1 V

Video output

Number/signal type.....	1 analog RGBHV, RGBS, RGsB, RsGsBs, component video (interlaced, progressive, HDTV), S-video, composite video
Connectors	5 BNC female
Nominal level	1.0 Vp-p for Y of component video and S-video, and for composite video 0.7 Vp-p for RGB (excluding sync) and for R-Y and B-Y of component video 0.3 Vp-p for C of S-video [excluding sync when gain and peaking potentiometers are set to unity gain (follows input)]

Minimum/maximum levels.....	Analog: 0.4 V to 2.0 V _{p-p}
Impedance.....	75 ohms
Return loss	-32 dB @ 5 MHz
DC offset	±6 mV with input at 0 offset

Sync

Input type	RGBHV, RGBS, RGsB, RsGsBs, YUV (bi-level and tri-level)
Output type.....	RGBHV, RGBS, RGsB, YUV (bi-level and tri-level)
Input standards	NTSC 3.58, NTSC 4.43, PAL, SECAM
Input level	
RGBHV, RGBS	TTL: 1.8 V to 5.0 V _{p-p}
RGsB, RsGsBs	Analog: 0.3 V _{p-p}
Output level	
RGBHV, RGBS	TTL: 5.0 V _{p-p} , unterminated
RGsB, RsGsBs	Analog: 0.3 V _{p-p} , follows input
Input impedance	510 ohms
Output impedance	50 ohms
Max. propagation delay	H: 50 ns, V: 110 ns
Max. rise/fall time	H: <3 ns, V: <3 ns
Polarity.....	RGBHV, RGBS: positive or negative (follows input) RGsB, RsGsBs: negative

General

Power	100 VAC to 240 VAC, 50/60 Hz, 3.6 watts, internal
Temperature/humidity.....	Storage: -40 to +158 °F (-40 to +70 °C) / 10% to 90%, noncondensing Operating: +32 to +122 °F (0 to +50 °C) / 10% to 90%, noncondensing
Mounting	
Rack mount.....	Yes, with optional 1U, 9.5" deep rack shelf (RSU 129, #60-190-01; RSB 129, 60-604-01); or 1U, 6" deep rack shelf (RSU 126, #60-190-10; RSB 126, 60-604-10).
Furniture mount.....	Yes, with optional under-desk mounting kit, part #70-077-01 (MBU 125) or through- desk mounting kit, part #70-077-02 (MBD 129).
Enclosure type	Metal

Specifications, Part Numbers, Accessories, cont'd

Enclosure dimensions	1.7" H x 8.7" W x 6.0" D (1U high, half rack wide) (4.3 cm H x 22.1 cm W x 15.2 cm D) (Depth excludes connectors.)
Product weight	1.5 lbs (0.7 kg)
Shipping weight	3 lbs (2 kg)
Vibration	ISTA 1A in carton (International Safe Transit Association)
Regulatory compliance	
Safety	CE, CUL, UL
EMI/EMC	CE, C-tick, FCC Class A, ICES, VCCI
Warranty	3 years parts and labor

NOTE *All nominal levels are at $\pm 10\%$.*

NOTE *Specifications are subject to change without notice.*

Parts

Included parts

Included parts	Replacement Part number
PA300	60-755-01
IEC power cord	
Rubber feet (4)	
<i>PA 300 Peaking Amplifier User's Manual</i>	

Optional accessories

Description	Part Number
1U, 9.5" deep Universal Rack Shelf, RSU 129	60-190-01
1U, 9.5" deep Basic Rack Shelf, RSB 129	60-604-01
1U, 6" deep Universal Rack Shelf, RSU 126	60-190-10
1U, 6" deep Basic Rack Shelf, RSB 126	60-604-10
1U, 1/2 Rack Width, Under-Desk Mount Kit, MBU 125	70-077-01
1U, 1/2 Rack Width, Through-Desk Mount Kit, MBD 129	70-077-02

Cables

BNC cables	Part number
MHR-5 BNC 3', 6', 12', 25', 35', 50', 75', 100'	26-260-xx
MHR-5P BNC 3', 6', 12', 25', 35', 50', 75', 100'	26-378-xx
M59-5 BNC 3', 6', 12', 25', 35', 50', 75', 100'	26-499-xx
RG6-5 BNC 3', 6', 12', 25', 35', 50', 75', 100'	26-369-xx
SYM BNCM 6", 1', 3', 6', 12', 25', 50', 75', 100'	26-533-xx

Specifications, Part Numbers, Accessories, cont'd

Extron's Warranty

Extron Electronics warrants this product against defects in materials and workmanship for a period of three years from the date of purchase. In the event of malfunction during the warranty period attributable directly to faulty workmanship and/or materials, Extron Electronics will, at its option, repair or replace said products or components, to whatever extent it shall deem necessary to restore said product to proper operating condition, provided that it is returned within the warranty period, with proof of purchase and description of malfunction to:

USA, Canada, South America, and Central America:

Extron Electronics
1001 East Ball Road
Anaheim, CA 92805
U.S.A.

Japan: Extron Electronics, Japan
Kyodo Building, 16 Ichibancho
Chiyoda-ku, Tokyo 102-0082
Japan

Europe, Africa, and the Middle East:

Extron Europe
Hanzeboulevard 10
3825 PH Amersfoort
The Netherlands

China:
Extron China
686 Ronghua Road, Songjiang
District
Shanghai 201611
China

Asia:

Extron Asia
135 Joo Seng Road, #04-01
PM Industrial Bldg.
Singapore 368363
Singapore

Middle East:

Extron Middle East
Dubai Airport Free Zone
F12, PO Box 293666
United Arab Emirates, Dubai

This Limited Warranty does not apply if the fault has been caused by misuse, improper handling care, electrical or mechanical abuse, abnormal operating conditions or non-Extron authorized modification to the product.

If it has been determined that the product is defective, please call Extron and ask for an Applications Engineer at (714) 491-1500 (USA), 31.33.453.4040 (Europe), 65.383.4400 (Asia), or 81.3.3511.7655 (Japan) to receive an RA# (Return Authorization number). This will begin the repair process as quickly as possible.

Units must be returned insured, with shipping charges prepaid. If not insured, you assume the risk of loss or damage during shipment. Returned units must include the serial number and a description of the problem, as well as the name of the person to contact in case there are any questions.

Extron Electronics makes no further warranties either expressed or implied with respect to the product and its quality, performance, merchantability, or fitness for any particular use. In no event will Extron Electronics be liable for direct, indirect, or consequential damages resulting from any defect in this product even if Extron Electronics has been advised of such damage.

Please note that laws vary from state to state and country to country, and that some provisions of this warranty may not apply to you.

Extron USA - West
Headquarters

+800.633.9876
Inside USA / Canada Only
+1.714.491.1500
+1.714.491.1517 FAX

Extron USA - East

+800.633.9876
Inside USA / Canada Only
+1.919.863.1794
+1.919.863.1797 FAX

Extron Europe

+800.3987.6673
Inside Europe Only
+31.33.453.4040
+31.33.453.4050 FAX

Extron Asia

+800.7339.8766
Inside Asia Only
+65.6383.4400
+65.6383.4664 FAX

Extron Japan

+81.3.3511.7655
+81.3.3511.7656 FAX

Extron China

+400.883.1568
Inside China Only
+86.21.3760.1568
+86.21.3760.1566 FAX

Extron Middle East

+971.4.2991800
+971.4.2991880 FAX

Free Manuals Download Website

<http://myh66.com>

<http://usermanuals.us>

<http://www.somanuals.com>

<http://www.4manuals.cc>

<http://www.manual-lib.com>

<http://www.404manual.com>

<http://www.luxmanual.com>

<http://aubethermostatmanual.com>

Golf course search by state

<http://golfingnear.com>

Email search by domain

<http://emailbydomain.com>

Auto manuals search

<http://auto.somanuals.com>

TV manuals search

<http://tv.somanuals.com>