

Specifications

Video input — RGB 580 χ i AAP / CCS AAP / CCSI AAP

Number/signal type 1 analog RGBHV, RGBS, RGsB, RsGsBs
 Connectors 1 15-pin HD female

Video output — RGB 580 χ i AAP / CCS AAP / CCSI AAP

Number/signal type 1 analog RGBHV, RGBS, RGsB
 Connectors 1 15-pin HD female

General

Temperature/humidity Storage -40° to +158°F (-40° to +70°C) / 10%
 to 90%, non-condensing
 Operating +32° to +122°F (0° to +50°C) / 10%
 to 90%, non-condensing

Enclosure dimensions

RGB 580 χ i AAP/Cable Cubby AAP models (double-height plates)
 Faceplate 1.4" H x 3.5" W (3.6 cm H x 8.9 cm W)
 Circuit board 1.3" H x 2.5" W x 0.9" D
 (3.3 cm H x 6.4 cm W x 2.3 cm D) Depth
 excludes connectors and knobs.

Shipping weight AAP models . 1 lb (0.5 kg)
 Vibration ISTA/NSTA 1A in carton (International Safe
 Transit Association)
 Approvals UL, CUL, CE, FCC Class A
 MTBF 30,000 hours
 Warranty 3 years parts and labor

NOTE Specifications are subject to change without notice.



User's Guide

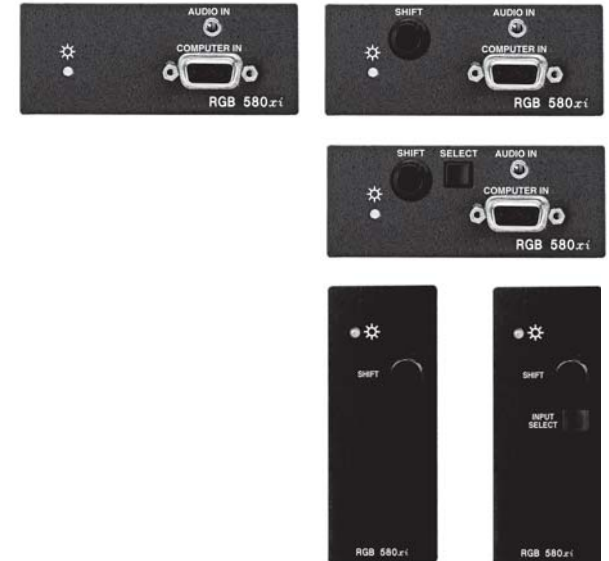

RGB 580 χ i AAP/CC AAP Series

RGB 580 χ i AAP, RGB 580 χ i S/CCS AAP,
 RGB 580 χ i SI/CCSI AAP



Extron Electronics, USA
 1230 South Lewis Street
 Anaheim, CA 92805
 USA
 714.491.1500
 Fax 714.491.1517

Extron Electronics, Europe
 Beeldschermweg 6C
 3821 AH Amersfoort
 The Netherlands
 +31.33.453.4040
 Fax +31.33.453.4050

Extron Electronics, Asia
 135 Joo Seng Road, #04-01
 PM Industrial Building
 Singapore 368363
 +65.6383.4400
 Fax +65.6383.4664

Extron Electronics, Japan
 Kyodo Building
 16 Ichibancho
 Chiyoda-ku, Tokyo 102-0082 Japan
 +81.3.3511.7655
 Fax +81.3.3511.7656

Installation and Operation

Extron's RGB 580 χ i AAP double-space devices are designed to complement the RGB 580 χ i remote interface. They may be mounted to any Extron product which has an AAP faceplate or to an AAP wallplate. See the "AAP Device Part Numbers" and the "Cable Cubby AAP Device Part Numbers" sections for AAP/CC AAP part numbers.

RGB 580 χ i AAP/CC AAP Series Features

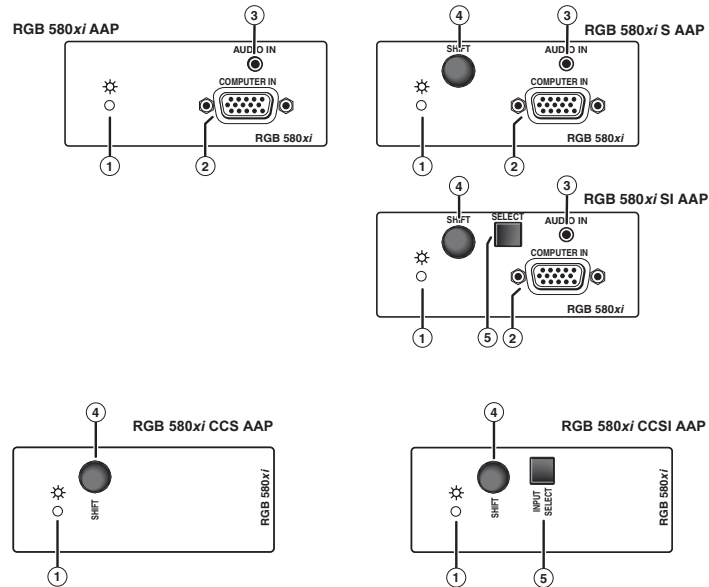

- 1 Power/signal LED** — This LED lights
 - amber to indicate that the AAP device is receiving power.
 - green to indicate that an active sync signal is present at the input and the AAP device is receiving power.

NOTE *The LED will flash green whenever the minimum and maximum limits of the horizontal shift control (H. shift) have been reached.*

- 2 Computer video input connector** — Attach a cable from the computer source to this 15-pin HD female connector.
- 3 Audio input connector** — Plug a 3.5 mm stereo plug into this jack for unbalanced audio input. Wire the male plug as shown in the following illustration.

Installation and Operation

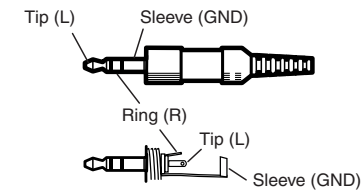

Audio input wiring

- 4 Horizontal shift control knob** — While viewing the displayed image, rotate this control to move the image to the right or left on the screen. The power/signal LED will flash green whenever the minimum and maximum limits of this control are reached.
- 5 Input select button** — Pressing this button will result in contact closure between pins A and B of the contact closure connector on the front panel of the RGB 580 χ i remote interface. This button can also be used for direct control of any Extron contact closure-controlled switcher, or as a direct connection to an external control system.

Mounting the RGB 580 χ i AAP Device

The AAP device should be cabled before attaching the AAP device to a faceplate or wallplate. The screws needed for installing an AAP device are built into its front panel, so no additional screws will be needed.

CAUTION *Installation and service must be performed by authorized personnel only.*

1. Connect the output cables to the AAP device's rear connectors. See the section "Cabling the AAP/Cable Cubby AAP Device Rear Connectors" in this user's guide.
2. Insert the AAP device's screws through the holes in the AAP double-space faceplate, the AAP wallplate, or the Cable Cubby AAP shelf bracket. Secure the AAP device to the faceplate/wallplate/shelf bracket with the provided captive washers and #4-40 nuts.

Installation and Operation

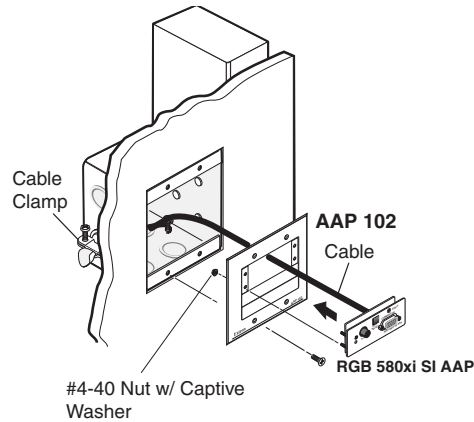

Example of mounting an AAP device to a wallplate

Cabling the AAP/Cable Cubby AAP Device Rear Connectors

Extron's various AAP/Cable Cubby AAP devices for the RGB 580xi may come with several rear connectors that may require cabling.

NOTE Although the control cable, LED, and audio assemblies will come prewired (AAP only) to the captive screw connectors, any subsequent cable assembly replacement will require the following cabling instructions.

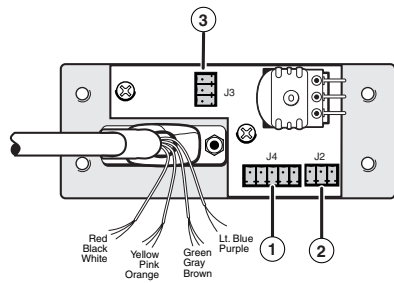

Example of AAP device rear connectors

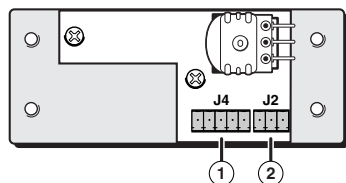

Example of Cable Cubby AAP device rear connectors

Installation and Operation

To cable the captive screw connectors, please refer to the following diagrams and orient the wires according to the view angle of the captive screws. When using Extron's VGA and control cable assembly (see the "Cables" section for part numbers), refer to the color of each wire for signal identification.

- Control connector (J4)** — Insert wires into and tighten the screws on this 3.5 mm, 5-pole captive screw connector. This connector is used for contact closure and horizontal shift signals. Wire the connector as shown below.

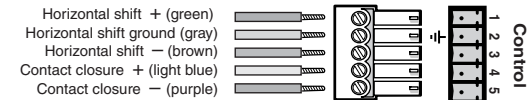

- LED connector (J2)** — Insert wires into and tighten the screws on this 3.5 mm, 3-pole captive screw connector. This connector is used for powering the green/amber LED. Wire the connector as shown below.

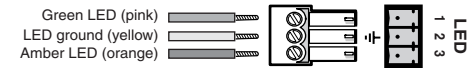

- Audio output connector (J3)** — Insert wires into and tighten the screws on this 3.5 mm, 3-pole captive screw connector. This connector is used for unbalanced stereo audio output. Wire the connector as shown below.

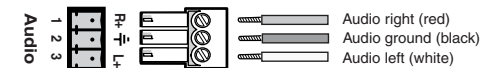

NOTE On Cable Cubby AAP models, the VGA and audio cable assemblies will be routed through the Cable Cubby. Refer to the Cable Cubby User's Manual (part #68-701-01) for Cable Cubby installation instructions.

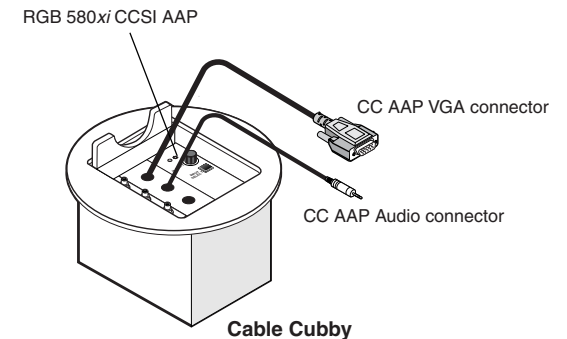

Part Numbers

AAP Devices

Description	Part number
RGB 580 χ i AAP 3' (black, white, RAL9010 white)	70-128-02, -03, -05
RGB 580 χ i AAP 6' (black, white, RAL9010 white)	70-129-02, -03, -05
RGB 580 χ i S AAP 3' (black, white, RAL9010 white)	70-134-02, -03, -05
RGB 580 χ i S AAP 6' (black, white, RAL9010 white)	70-135-02, -03, -05
RGB 580 χ i SI AAP 3' (black, white, RAL9010 white)	70-137-02, -03, -05
RGB 580 χ i SI AAP 6' (black, white, RAL9010 white)	70-138-02, -03, -05

Cable Cubby AAP Devices

Description	Part number
RGB 580 χ i CCS AAP 9' (black)	70-254-02
RGB 580 χ i CCS AAP 12' (black)	70-255-02
RGB 580 χ i CCSI AAP 9' (black)	70-256-02
RGB 580 χ i CCSI AAP 12' (black)	70-257-02

Part Numbers

Optional RGB 580 χ i AAP Extension Cables

NOTE *These cables only apply to the RGB 580 χ i AAP, RGB 580 χ i S AAP, and RGB 580 χ i SI AAP, they do not apply to the RGB 580 χ i CCS AAP or RGB 580 χ i CCSI AAP.*

VGA and control cable assembly	Part number
VGA and control cable 3' (0.9 m)	26-521-01
VGA and control cable 6' (1.8 m)	26-521-02
VGA and control cable 12' (3.6 m)	26-521-03
VGA and control cable 25' (7.6 m)	26-521-04
VGA and control cable 35' (10.6 m)	26-521-05
VGA and control cable 50' (15.2 m)	26-521-06

Free Manuals Download Website

<http://myh66.com>

<http://usermanuals.us>

<http://www.somanuals.com>

<http://www.4manuals.cc>

<http://www.manual-lib.com>

<http://www.404manual.com>

<http://www.luxmanual.com>

<http://aubethermostatmanual.com>

Golf course search by state

<http://golfingnear.com>

Email search by domain

<http://emailbydomain.com>

Auto manuals search

<http://auto.somanuals.com>

TV manuals search

<http://tv.somanuals.com>