



FEATURES

- Single channel DC restored video
- Small sealed enclosure
- Remote operation (200 ft.)
- Dynamic range 2000:1 minimum
- Video data rates to 20 MHz
- Precise sensor alignment
- AR coated window sensor (optional)

GENERAL DESCRIPTION

The CAM1X50 is a new generation of modular line scan cameras designed for incorporation into non-contact electro-optical measurement and process control systems. It is available in 512 1024, or 2048 pixel resolutions. Either single or dual video output channels, with or without DC restoration, can be supplied.

To operate the camera, two differential clock inputs and power are required. A DATA RATE clock with frequencies up to 20 MHz, will determine the video data rate. A LINE RATE clock controls the camera scan rate. The camera outputs a LINE SYNC and DATA RATE differential signals for system interfacing and synchronization. These signal lines should use properly terminated, shielded twisted pair cabling for interconnection.

The camera requires power supply inputs of +5, +15 and -15 volts DC, internal regulators and filters provide noise immunity for the CCD sensor bias voltages. The 75Ω source impedance analog video is available on two coaxial connection as a single or dual (odd/even) channel of unrestored or DC restored video.

FUNCTIONAL DESCRIPTION

The circuitry within the camera is comprised of differential line drivers and receivers, timing control logic, a CCD linear imaging sensor, DC restoration, video combining, output gain and buffering.

IMAGE SENSOR

The Charge Coupled Device (CCD) used in the CAM1X50 is a high speed linear imaging sensor with 512, 1024 or 2048 photoelements. This device is a monolithic component containing a single row of 13μm x 13μm light sensing elements (photosites or pixels), two analog shift registers, and two output sense amplifiers that provide separate odd and even channels of sensor video.

Light energy detected by the photosites generate electron charge packets proportional to the product of integration time and incident light intensity. Periodically the collected photosite charge packets are transferred in parallel to their respective odd and even analog shift registers in response to a low to high transition of the ϕ_x sen-



sor input signal. The shift registers, clocked by the sensor ϕ_T input, deliver the charge to packets to a charge sensing amplifier where they are converted to proportional voltage levels. This synchronous stream of analog voltage levels is available on the sensor VIDEOOUTA and VIDEOOUTB pins.

CAMERA TIMING

The CAM1X50 is driven by supplying two differential RS-422 like clocks. The DATA RATE clock input will determine the video pixel output rate. The LINE RATE clock input controls the camera exposure and scanning rate. The frequency of the LINE RATE clock determines the camera scan rate, while the interval between successive clocks is the period for which the CCD has integrated light.

The camera outputs a LINE SYNC and DATA RATE differential signals are used for system interfacing. LINE SYNC indicates the start of a new scan readout and always precedes the first active pixel by 23 clocks. The DATA RATE output is used as a digitize clock for an A/D to accommodate propagation delays due to long cable lengths.

The differential line driven clock inputs are converted into TTL levels within the camera by differential line receivers. Single ended TTL input clocks may be used at low data rates for short cable lengths if the negative clock input is biased at +1 volt. Operating the camera in this single ended mode is not guaranteed and camera performance varies with application implementation.

VIDEO

The two video outputs of the CCD sensor are DC restored on the dark reference cells that precede each scan line. The video is combined into a single channel of sequential pixels with a high speed video switch. The video is then inverted and amplified to provide a positive 1 volt peak signal at sensor saturation when terminated into 75Ω.

CAM1X50

OPTICAL COMPONENTS

Each photosite element is 13 μ m (0.0051 inch) square. The total active array length is 6.65mm (0.26 inch), 13.3mm (0.52 inch), and 26.6mm (1.04 inch) for the CAM 1250, CAM1350, and CAM1550, respectively. The CAM1250 has a resolution of 512 elements. The CAM1350 has a resolution of 1024 elements. The CAM1550 has a resolution of 2048 elements.

All cameras are shipped with a removable Schott KG-1 infrared blocking optical filter inserted in the camera faceplate lens opening. The filter transmission convolved with the sensor spectral response yields a camera response from about 400nm to 800nm, with a peak response at about 600nm.

Cameras with a resolution of 512 or 1024 elements are supplied with a removable C lens mounting ring for use with standard 1 inch format CCTV lens. An Olympus or Nikon Bayonet mount is provided for the 2048 element CAM1550, which is specified in the camera order suffix code.

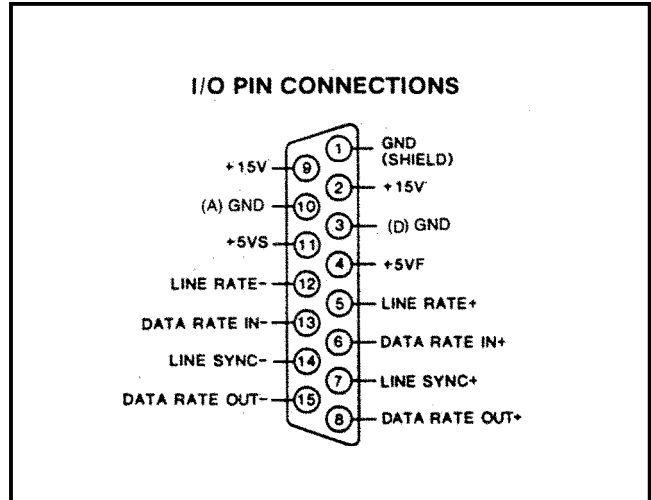

OPERATING CONDITIONS

SYMBOL	PARAMETER	RANGE			UNITS
		MIN	TYP	MAX	
f _{DR}	DATA RATE Frequency	0		20	MHz
+15VDC	15 Volt DC Power Supply	14.8	15.0	15.2	V
+5 VDC	5 Volt DC Power Supply	4.5	5.0	5.5	V
-15 VDC	-15 Volt DC Power Supply	-15.2	-15.0	-14.8	V
T _A	Operating Temperature	0.0		60	°C
T _S	Storage Temperature	-40.0		100	°C

PERFORMANCE CHARACTERISTICS (Conditions: T_a = 25°, f_{DR} = 1MHz, t_{INT} = 8.33 msec, nominal voltages.)

SYMBOL	PARAMETER	RANGE			UNITS
		MIN	TYP	MAX	
V _{SENS}	Differential Input Sensitivity	200			mV
V _{HYS}	Differential Input Hysteresis	120			mV
V _{SAT}	Saturation Output Level	0.9	1.0	1.2	V
V _{RIPPLE}	Output Signal Coherent Hoise (P-P)		25	50	mV
N _{PP}	Random Noise (P-P)			2.5	mV
N _{RMS}	Random Noise (RMS)			450	μ V
V _{OFF}	DC Offset			50	mV
DR	Dynamic Range (relative to P-P noise) (relative to RMS noise)	360:1 2000:1			
SE	Saturation Exposure		0.67		μ J/cm ²
CTE	Charge Transfer Efficiency	.99995	.99998		
PRNU	Photoresponse Non-uniformity (P-P)		\pm 3	\pm 5	%
DSNU	Dark signal Non-uniformity		10	20	mV
R	Responsivity		3.0		V/ μ J/cm ²

CAM1X50

MECHANICAL DIMENSIONS

(NOTE: ALL DIMENSIONS ARE IN INCHES UNLESS SPECIFIED)

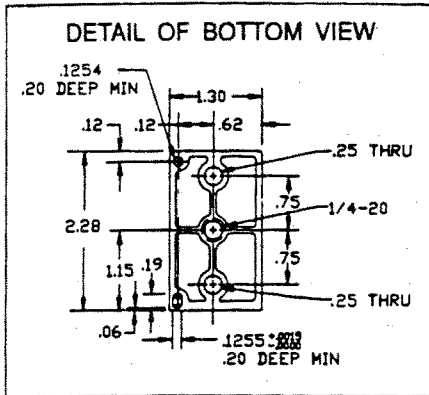
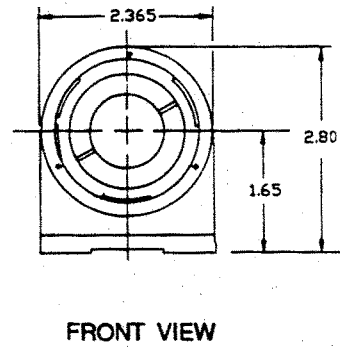
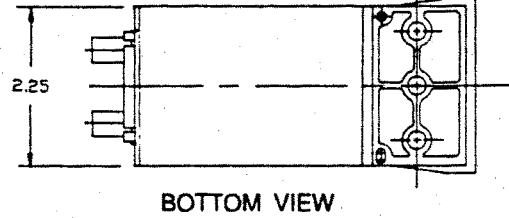
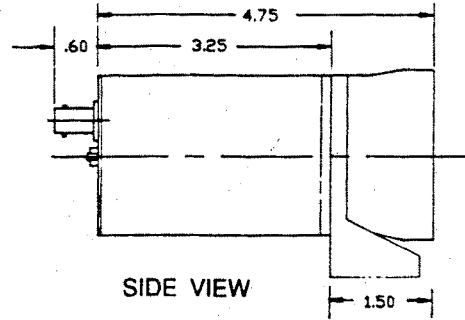
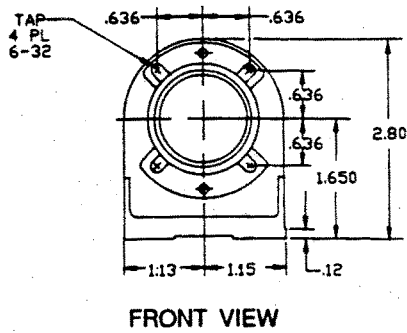
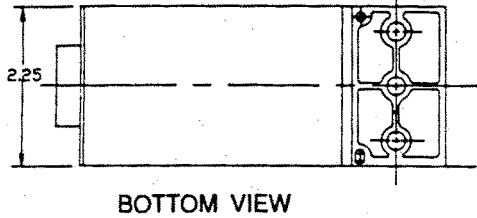
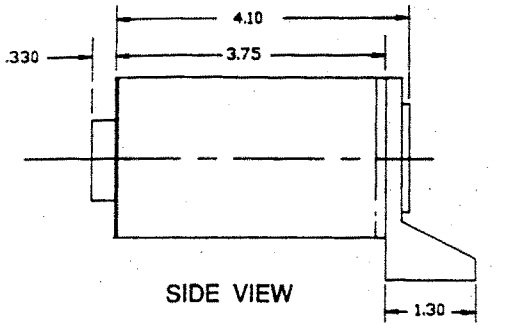

REAR VIEW

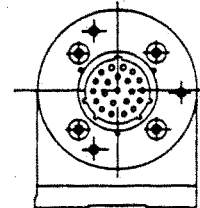
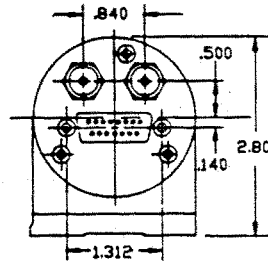

CAM1X50

SIGNAL DESCRIPTIONS

Power and Grounds

SIGNAL NAME	PIN	DESCRIPTION
GND SHIELD	1 (U, V)	Shield ground.
AGND	10, (B)	Analog ground. All the analog ground pins are connected internally.
DGND	3 (D)	Digital ground. This ground is isolated from AGND.
+15 VDC	9 (C)	+15 Volt DC Supply (30mA @ 20MHz)
+ 5 VDC	4, 11 (A)	+ 5 Volt DC Supply (420mA @ 20MHz)
-15 VDC	2 (T)	-15 Volt DC Supply (120mA @ 20MHz)

Inputs

SIGNAL NAME	PIN	DESCRIPTION
DATA RATE (+) DATA RATE (-)	6 (G) 13 (H)	Data rate clock. Duty cycle must be 45–55%. Data is output at this frequency.
LINE RATE (+) LINE RATE (-)	5 (E) 12 (F)	Line control clock. New lines are started on the low to high transition of this clock. The state of this clock is sensed on the rising edge of DATA RATE.

Outputs

SIGNAL NAME	PIN	DESCRIPTION
VOUT	BNC	Video output.
DATA RATE (+) DATA RATE (-)	8 (J) 15 (K)	Output pixel data rate.
LINE SYNC (+) LINE SYNC (-)	7 (L) 14 (M)	Pulse indicating start of new line.

ORDERING INFORMATION

The CAM1X50 can be ordered in a variety of configurations. Camera resolutions of 512, 1024 and 2048 elements are available for the CAM1250, CAM1350 and CAM1550 respectively. The camera interface connector may be standard 15 pin D or rugged industrial Burndy. Selection of lens mount, as well as output video format, is specified when the camera is ordered.

All Fairchild Imaging cameras and camera systems can be modified to suit unusual applications. The CCD Imaging Division is interested in developing and manufacturing customized versions of the basic camera for volume purchasers. Contact the Marketing department to discuss design modifications, pricing, and application support.

ORDER CODE

- C — C Mount*
- N — Nikon Mount
- O — Olympus Mount
- R — DC Restored Video
- V — Buffered Raw Sensor Video
- D — Mail 15 pin D connector
- I — Industrial 22 pin Burndy connector
- 1 — Combined single channel Output
- 2 — Dual Channel Output

EXAMPLE: CAM1350CRDI

* Not recommended for CAM1550

WARRANTY

Within twelve months of delivery to the end customer, Fairchild Imaging will repair or replace, at our option, any Fairchild Imaging camera product if any part is found to be defective in materials or workmanship. Contact factory for assignment of warranty return number and shipping instructions to ensure prompt repair or replacement.

CERTIFICATION

Fairchild Imaging certifies that all products are carefully inspected and tested at the factory prior to shipment and will meet all requirements of the specification under which it is furnished.

SPECIALS

All Fairchild Imaging CCD cameras and camera systems can be modified to suit unusual applications. The CCD Imaging Division is interested in developing and manufacturing customized versions of the basic camera for volume purchasers and is willing to assist low-volume purchasers in development of custom modifications by provision of design and applications engineering assistance.

Free Manuals Download Website

<http://myh66.com>

<http://usermanuals.us>

<http://www.somanuals.com>

<http://www.4manuals.cc>

<http://www.manual-lib.com>

<http://www.404manual.com>

<http://www.luxmanual.com>

<http://aubethermostatmanual.com>

Golf course search by state

<http://golfingnear.com>

Email search by domain

<http://emailbydomain.com>

Auto manuals search

<http://auto.somanuals.com>

TV manuals search

<http://tv.somanuals.com>