

Fellowes®

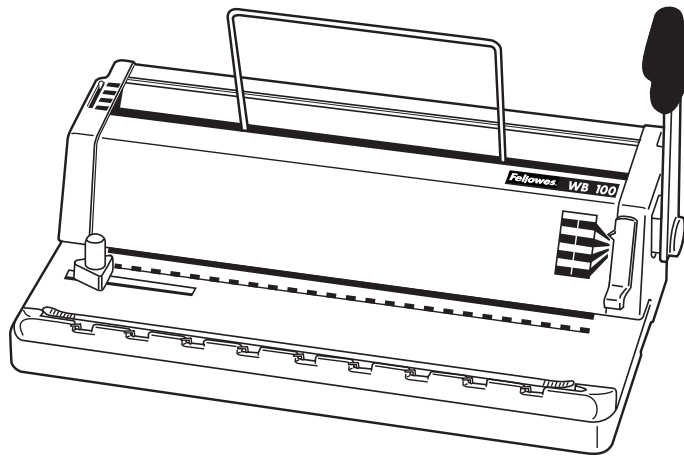

Operating Instructions

A

Operating Instructions

B

Operating Instructions

C

Model:

WB 100

Equipment Parts

1. Punching/Crimping Handle
2. Punching Area
3. Adjustable Margin Guide
4. Wire Size Selector
5. Paper Support
6. Binding Support
7. Crimping Area
8. Crimping Area Adjustor Dial
9. Waste Paper Tray
10. Crimping Area Size Indicator

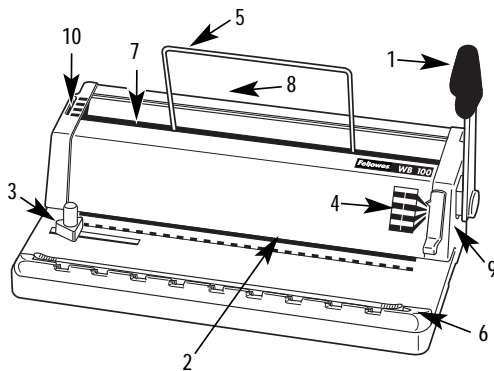

2. Slide all sheets to the back of the punching area.
Note: a maximum of 8 sheets can be punched at a time.
3. Lower the handle to punch holes in paper.
4. Return handle to its original vertical position and remove sheets.
5. Repeat until all sheets and covers have been punched.

Determining Wire Size

The WB 100 Binding Machine has a built-in Wire Size Selector to simplify the binding process. To determine correct size, insert entire document to be bound under Wire Size Selector. Move Selector downward until the bottom portion touches document. Read the corresponding Wire Size on the Selector.

Binding the Document

1. Move the Crimping Area Adjustor to the correct position so it corresponds with the appropriate Wire Size according to the Wire Size Selector.
2. Place wire on binding support hooks with open side facing upward. Slide plastic guide strip above hooks to the right to lock wire binding in place.
3. Insert the punched sheets onto the wire binding.
NOTE: For a correctly bound presentation, the opening of the binding should be placed between the last page and back cover of the document.
4. Slide plastic guide strip to the left, back to its original starting position, and remove entire presentation.
5. Holding document in a vertical position, carefully insert wire binding element into the Crimping Area.
NOTE: Wire Binding element should be in an inverted "U" position.
6. To secure document, crimp Wire Binding element by lowering the Punching/Crimping Handle.
7. Return handle to its original vertical position and remove document.

Emptying Paper Clippings

To remove, simply slide the waste paper tray out from the right side of the machine.

To prevent clogging and jamming, be sure to empty waste paper tray frequently.

Assembly

To assemble your WB 100 Wire Binding Machine, simply attach the Punching Handle to the right side of the machine and secure with the screw supplied. Next, attach Paper Support in Crimping Area as show in the diagram.

Using the Binding Machine

Punching holes

1. Holes should always be centered between the top and the bottom of paper edge. To center holes, set the adjustable margin guide on the left-side of the machine for oversized covers (8-3/4" x 11-1/4") or letter size documents (8-1/2" x 11"). For optimum results, first use several "practice sheets" to set up margin guide position.

A

B

C

Specifications

Maximum Binding Length	11" (279mm)
Maximum Punching Capacity (at a time)	8 sheets
Maximum Binding Capacity	120 sheets
Maximum Binding Diameter	5\8" (16mm)
Dimensions (LxWxH)	14-3\8" x 8-9\16" x 7-1\4"
Weight	11lbs. (5kg)
Warranty	1 Year

Limited Warranty

Fellowes Manufacturing Company warrants all PB Model Binding Machines to be free from defects in material and workmanship for a period of one year from the date of purchase by the original consumer. The exception to this are the punching dies which are subject to wear. If any part is found to be defective during the warrant period, your sole and exclusive remedy will be repair or replacement, at Fellowes' option and expense, of the defective part.

This warranty does not apply in cases of abuse, mishandling or unauthorized repair. ANY IMPLIED WARRANTY, INCLUDING THAT OF MERCHANTABILITY OR FITNESS FOR A PARTICULAR PURPOSE, IS HEREBY LIMITED IN DURATION TO THE APPROPRIATE WARRANTY PERIOD SET FORTH ABOVE. In no event shall Fellowes be liable for any consequential or incidental damages attributable to this product. This warranty gives you specific legal rights. You may have other legal rights which vary from state to state. To obtain service under this warranty on machines purchased in the USA, return the machine prepaid to the address below. Please allow two weeks for processing.

Return with machine:

- Copy of original sales receipt.
- A card stating your name, address, daytime telephone number, machine model and serial number, plus a brief description of the problem.

For specific instructions on obtaining service under this warranty on machines purchased outside the USA, contact the appropriate location listed below.

Warrantor: Fellowes Manufacturing Company



U.S.	1-800-955-0959
Australia	+ 6139-330-3211 (inside Melbourne) 1-800-331-177 (outside Melbourne)
Benelux	+ 31-3473-77988
Canada	1-800-665-4339
France	+ 334-789-12279
Germany	+ 4951-31-49770
Japan	+ 81-3-5496-2401
U.K.	+ 44-1302-885331

Fellowes 1789 Norwood Avenue, Itasca, Illinois 60143-1095 630-893-1600 Customer Service 1-800-945-4545 <http://www.fellowes.com>

Australia	Benelux	Canada	France	Germany	Italy	Japan	Poland	United Kingdom
Tullamarine, Vic	Vianen, NL	Markham, Ont.	Rennes, I-V	Garbsen, Han.	Camerano, AN	Tokyo	Warsaw	Doncaster, S. Yorks.

Part No.

© 2000 Fellowes Printed in U.S.A.

Free Manuals Download Website

<http://myh66.com>

<http://usermanuals.us>

<http://www.somanuals.com>

<http://www.4manuals.cc>

<http://www.manual-lib.com>

<http://www.404manual.com>

<http://www.luxmanual.com>

<http://aubethermostatmanual.com>

Golf course search by state

<http://golfingnear.com>

Email search by domain

<http://emailbydomain.com>

Auto manuals search

<http://auto.somanuals.com>

TV manuals search

<http://tv.somanuals.com>