

X SERIES LOUDSPEAKER SYSTEMS



From Fender Pro Audio

Owner's Manual for
1110X / 1201X / 1205X

P/N 052048





FENDER
PA
BUILT FROM THE SOUND UP™

sunn 



Fender Musical Instruments
7975 North Hayden Road, Scottsdale, Arizona 85258 U.S.A.

A Message from the Chairman

At Fender, we know the importance of sound reinforcement. From the simple box-top powered mixer to today's touring concert systems, the need to communicate to make the connection between the performer and the audience is foremost in our mind.

Perhaps no other piece of gear can make or break your message or your band's sound than your sound reinforcement gear. Your sound system is far more than just a combination of dials, wires and speakers. It is an integral part of the audio chain and should be treated with special care and attention to detail.

Fender knows what building quality musical instruments and sound reinforcement equipment is all about. In fact, many of the world's best sounding electric musical instruments and sound reinforcement equipment proudly wear the Fender name.

Whether you need a small powered mixer for your Saturday afternoon "jam" or a professional full-size concert system, Fender has the sound reinforcement gear to meet your needs. Likewise, your decision to purchase quality Fender Professional Audio Equipment is one you will appreciate with each performance for years to come.

Wishing you years of enjoyment and a heartfelt *thank you*,

Bill Schultz

Bill Schultz
Chairman of the Board
Fender Musical Instruments Corporation



1110X / 1201X / 1205X PROFESSIONAL LOUDSPEAKER SYSTEMS

INTRODUCTION

High Current 1/4" Phone Jacks

Thank you for purchasing an X Series 1110X / 1201X / 1205X Loudspeaker System from Fender® Pro Audio. We are sure you will find it both a unique and effective sound reinforcement product, providing years of trouble-free service day in and day out.

Dual Piezoelectric Horn

Rugged Metal Grille

X Series Loudspeaker Systems are professional, full-range, two-way, compact loudspeakers designed for the most demanding permanent or portable sound reinforcement requirements. Moreover, these speakers are ideal for use as a two-way system or as the mid / high pack in a three-way set-up incorporating a Fender 115sA / 118sA subwoofer loudspeaker system.

Metal Corners and Rubber Feet

X Series Loudspeaker Systems are designed to form the basis of everything from a small public address system to the nightly rigors of a "working band's" sound system. After moisture sealing, X Series cabinets are covered in tough black Tolex® covering. Likewise, X Series cabinets also feature metal corners and rubber feet for a longer life and lasting looks.

Tough Tolex® Covering

Please read through this owner's guide in order to more fully understand the operational characteristics of your X Series Loudspeaker enclosure.

CAUTION: Almost all speakers produce strong magnetic fields which may interfere with the normal operation of nearby electronic devices, including televisions and computer video monitors. To reduce or eliminate interference, increase the distance between this product and other nearby electronic devices.

SPEAKER WIRING AND CONNECTIONS

Parallel or series are the two basic ways which multiple speakers can be connected to a single power amplifier. When speakers are connected in parallel, their combined impedance decreases. For speakers wired in series the opposite is true, their combined impedance increases. Thus, when speakers are wired in series, higher impedance speakers in the series draw more power from the amplifier than do speakers in the series with lower impedances. When speakers are wired in parallel, the opposite is true. Higher impedance speakers will draw less power from the amplifier than lower impedance speakers will draw.

At Fender®, we recommend connecting multiple speakers in parallel for several reasons. First, if one speaker fails, the others will continue to operate. Second, because in a series connection one speaker affects the output of the other speakers, unpredictable frequency response is a concern. Third, most speaker cabinets are already wired for parallel connections making parallel connections the most common wiring method.

Below are two charts demonstrating how to calculate both parallel and series impedance.

PARALLEL IMPEDANCE

Cabinet B Impedance	16Ω*	5.3*	8
	8Ω	4	5.3
	8Ω * 16Ω		
	Cabinet A Impedance		

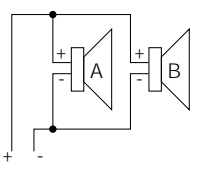
$$Z_p = \frac{1}{\frac{1}{Z_1} + \frac{1}{Z_2} + \dots + \frac{1}{Z_n}}$$

*Example- Cabinet A is 8 ohms. Cabinet B is 16 ohms. The total impedance when connected in parallel is:

$$Z_p = \frac{1}{\frac{1}{8} + \frac{1}{16}} = 5.3 \text{ ohms.}$$

SERIES IMPEDANCE

Cabinet B Impedance	16Ω*	18	20*	24	32
	8Ω	10	12	16	24
	4Ω	6	8	12	20
	2Ω	4	6	10	18
	2Ω 4Ω* 8Ω 16Ω				
	Cabinet A Impedance				

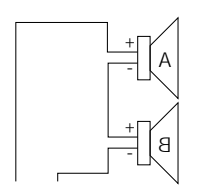
$$Z_s = Z_1 + Z_2 + \dots + Z_n$$

Keep in mind, power and audio signal cables are the most common sources of sound system failure. Well made and carefully maintained cables are essential to the reliability of the entire sound system. If long speaker cables are required, it is important to ensure the cable's gauge is sufficient to transfer all of the available amplifier power to the speakers rather than absorbing the power itself. As a rule of thumb, larger wires are better as they conduct more power to the speakers (larger wire has smaller gauge numbers).

Below are two charts listing speaker wire gauges and recommendations for best results.

SPEAKER WIRE GAUGE

SPEAKER WIRE LENGTH	100'-UP (30.5 m-UP)	10	12	14
	50'-100' (15.25-30.5 m)	12	14	16
	*25'-50' (7.60-15.25 m)	14	*16	18
	10'-25' (3.05-7.60 m)	16	18	18
	0'-10' (0.00-3.05 m)	18	18	18
		4Ω	*8Ω	16Ω

SPEAKER IMPEDANCE [z]

*Example - If the speaker wire length required is between 25-50 feet (7.60-15.25 meters) and the speaker impedance is 8Ω, the minimum recommended speaker wire gauge is 16.

AWG	Cross-Section [mm ²]	Resistance in Ω per foot (30.5 cm) @ 77° F (25° C)
18	0.83	.00651
16	1.32	.00409
14	2.10	.00258
12	3.32	.00162
10	5.27	.00102
8	8.38	.00064

X SERIES SPEAKER CONNECTIONS

The X Series Loudspeaker Systems' 1/4" jacks are wired in parallel allowing any one of the connectors to be used as an input and any other as an output. This allows "daisy chaining" of multiple loudspeakers, eliminating the need for several long, cumbersome runs of speaker cable (see diagram on page 6). Their connections are as follows:

Polarity	Phone Jack
Positive (+)	Tip
Negative (-)	Sleeve

If X enclosures are used as the mid / high pack in a larger three-way loudspeaker array, an external crossover may be used with the speaker and two channels of power amplification will be required: one for the low frequencies and another for the high frequencies (see diagram on page 7).

SETUP SUGGESTIONS

The placement of any speaker can dramatically affect its sound. Thus, there are several considerations to review when placing loudspeakers.

First, the range of the horizontal coverage should be determined. The speaker may be used as a single unit, as part of a pair, or as part of a group of widely spaced enclosures, in any case, maximum horizontal coverage will be desired. Examples of these types of setups are shown. The horn in this configuration has a horizontal coverage angle of 70° and a vertical coverage of 35°.

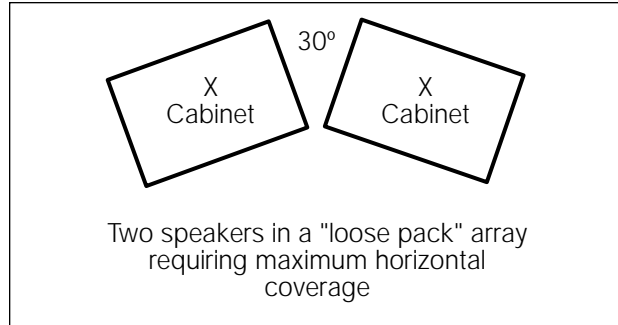
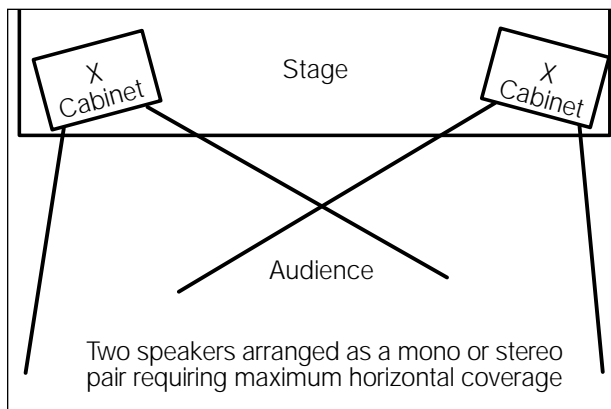

NOTE: When setting up your X Series enclosures, be sure to place the cabinets in such a way as to minimize overlapping radiating patterns.

A **second** consideration is for feedback and bass performance. If the speaker is placed near a large, flat wall, the bass output will increase by approximately 6 dB. Placing the speaker near a wall can cause feedback. If this occurs, the speaker must be moved.

A **third** consideration is to what degree the speaker should be "heard and not seen", especially in permanent installations. Remember, where the speaker cabinets are placed will effect both their tone and radiating patterns.

CARPET COVERING CARE



X Series cabinets are covered in a tough, black Tolex covering for long life and lasting good looks. To clean the Tolex covering, use a sponge and a light soapy water solution to wipe away any smudges or dirt. For stubborn stains, a slightly more concentrated soapy solution may be used. Avoid spilling liquids on the input panel, grille and speakers.

"DAISY CHAINING" X SERIES ENCLOSURES

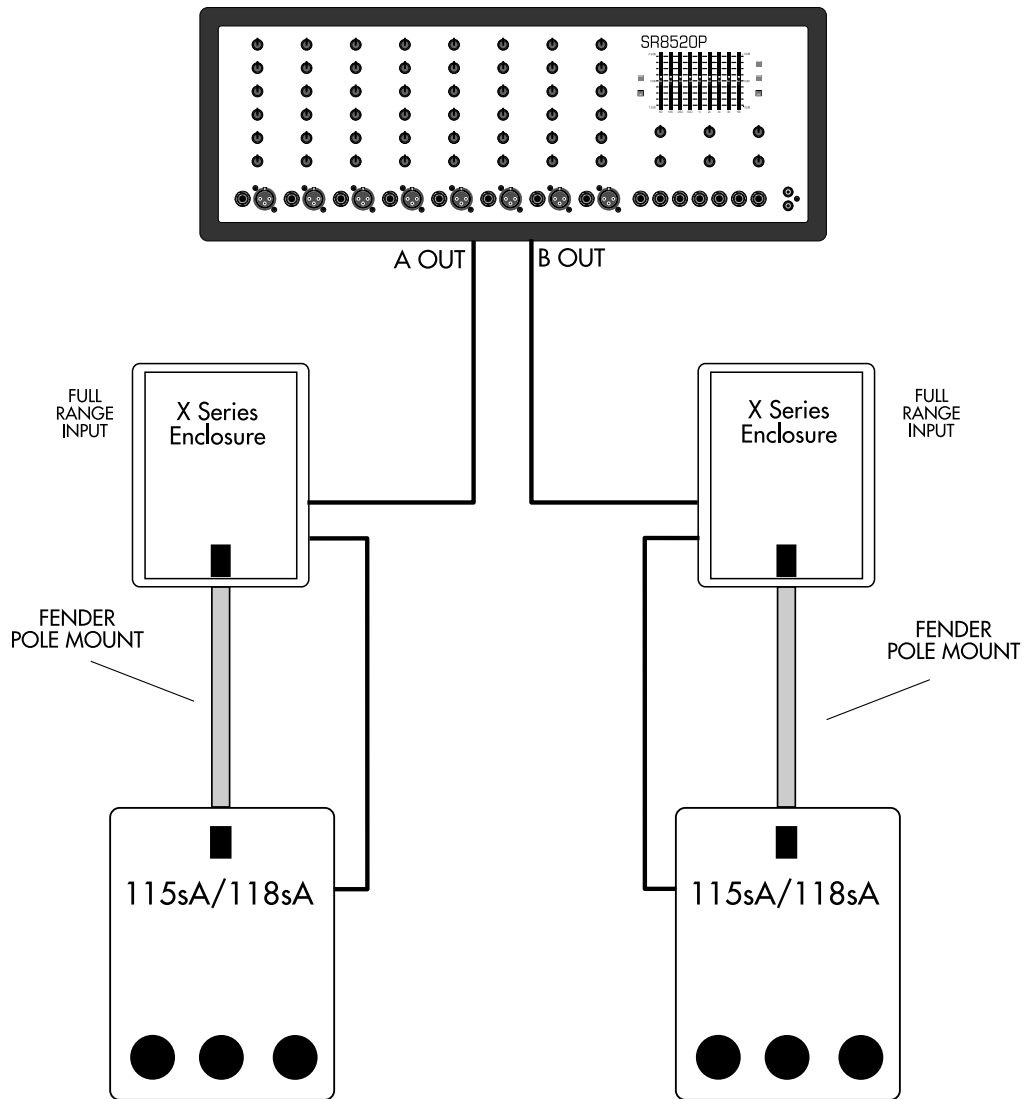

USING AN ELECTRONIC CROSSOVER WITH X SERIES ENCLOSURES

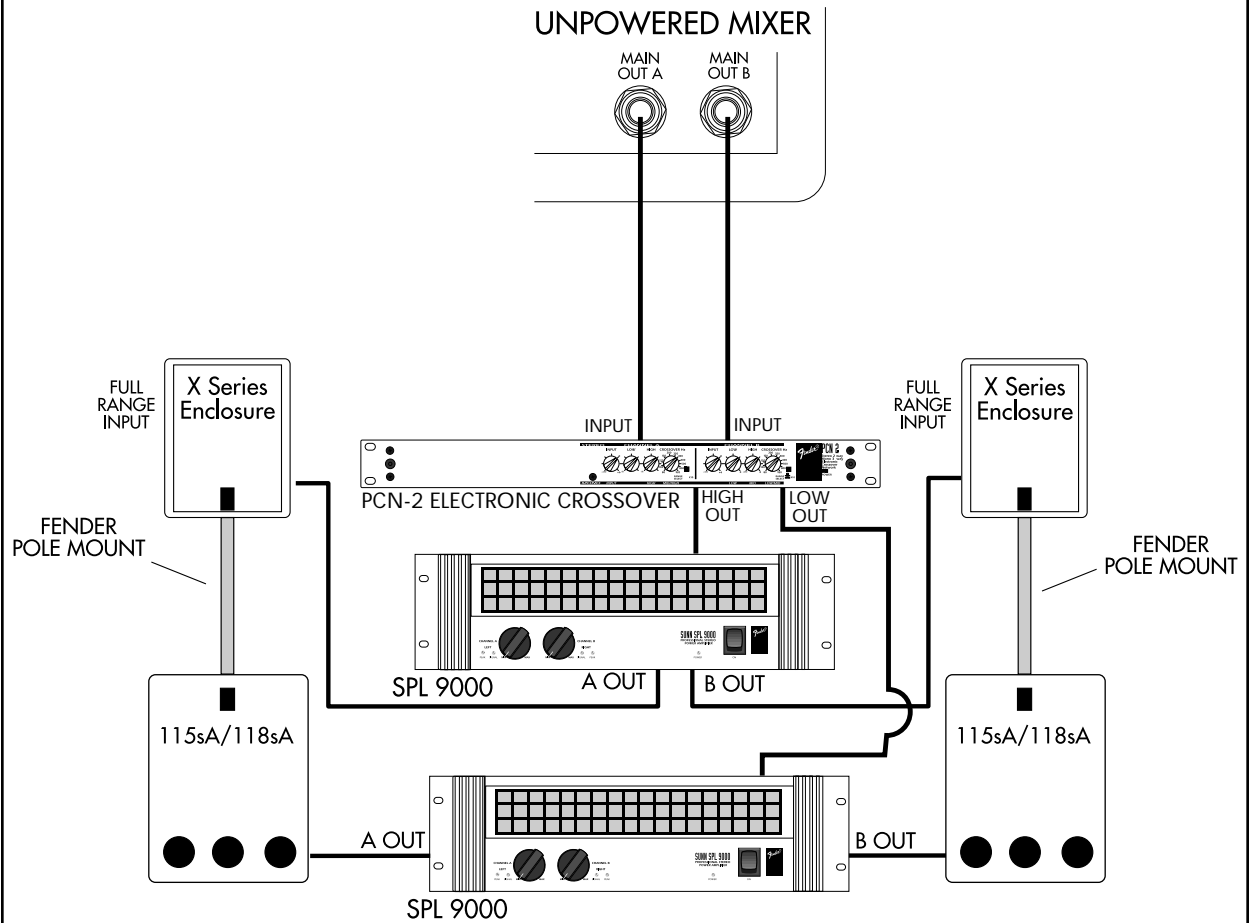

SPECIFICATIONS

MODEL		1110X	1201X	1205X
PART NUMBER		071-1100-200	071-1201-200	071-1205-200
MAXIMUM dB SPL OUTPUT LONG TERM		120 dB	121 dB	121 dB
CABINET		3/4" (1.9 cm) Birch Plywood	3/4" (1.9 cm) Birch Plywood	3/4" (1.9 cm) Birch Plywood
CONNECTIONS		(2) 1/4" Phone Jacks	(2) 1/4" Phone Jacks	(2) 1/4" Phone Jacks
DRIVER	Low:	10" (25.4 cm) woofer 2" (5 cm) voice coil	12" (30.5 cm) woofer 2" (5 cm) voice coil	15" (38.1 cm) woofer 2.5" (6.35 cm) voice coil
	High:	1" (2.5 cm) Exit Throat Polymer Diaphragm Dual Piezoelectric Driver	1" (2.5 cm) Exit Throat Polymer Diaphragm Dual Piezoelectric Driver	1" (2.5 cm) Exit Throat Polymer Diaphragm Dual Piezoelectric Driver
FREQUENCY RESPONSE	Axial +/- 3 dB:	65 Hz to 20kHz	60 Hz to 20kHz	60 Hz to 20kHz
AXIAL SENSITIVITY	SPL @ 1W/1m:	94 dB	95 dB	95 dB
POWER RATING		100W	100W	150W
NOMINAL IMPEDANCE		8Ω	8Ω	8Ω
DIMENSIONS	Height	19.5" (49.3 cm)	21" (53 cm)	25.25" (64 cm)
	Width	16" (40.5 cm)	17" (43.2 cm)	19.25" (48.7 cm)
	Depth	11" (28 cm)	12.6" (32 cm)	13" (33 cm)
WEIGHT		35 lbs. (15.9kg)	47 lbs. (21.5 kg)	55 lbs. (25 kg)

A PRODUCT OF:
FENDER MUSICAL INSTRUMENTS CORP.
 CORONA, CA 91720 USA

Free Manuals Download Website

<http://myh66.com>

<http://usermanuals.us>

<http://www.somanuals.com>

<http://www.4manuals.cc>

<http://www.manual-lib.com>

<http://www.404manual.com>

<http://www.luxmanual.com>

<http://aubethermostatmanual.com>

Golf course search by state

<http://golfingnear.com>

Email search by domain

<http://emailbydomain.com>

Auto manuals search

<http://auto.somanuals.com>

TV manuals search

<http://tv.somanuals.com>