

Fender[®]

THE SOUND THAT CREATES LEGENDS

KEYBOARD
EXTENDED
RANGE **KXR**

One hundred
TYPE: PR 262

Owner's Manual

P/N 047761

KXR 100 Owner's Manual

Congratulations on your purchase of the **Fender KXR 100 keyboard** amplifier. The **Fender KXR 100** is the most recent effort in state of the art keyboard amplifier technology, and is a member of the **FENDER KXR** series. The design execution of the **KXR 100** was carried out with the aid of some of today's best musicians, and represents years of thought and consideration in determining features and specifications.

The **KXR 100** is actually much more than a keyboard amp. With its heavy-duty *Fender Special Design* speaker and dual piezo-electric horn, it could actually be classified as a self-contained portable PA. system, suitable for almost any musical instrument requiring full-range reinforcement, for example electronic keyboards, acoustic/electric guitar, electric violin, and voice. Compact packaging and medium-level output power make the **KXR 100** the perfect full-range instrument amplifier for rehearsal, studio, or small club performances.

The preamp section of the **KXR 100** features three independent channels, a 4 band master EQ, and master reverb and volume controls. Each channel features a single 1/4 inch input jack and volume control. In addition to the 1/4 inch input jack, channel #1 features an XLR input jack for the connection of a low impedance microphone. The EFFECTS SEND and EFFECTS RETURN jacks can be used with a wide variety of effects devices, or as patch points for slaving multiple amps together. The EFFECTS SEND can also be used to connect your **KXR 100** directly to a recording console or sound reinforcement mixer.

The HEADPHONE jack automatically mutes the speaker while driving stereo or mono headphones for private practice sessions. The HEADPHONE jack can also be used as another line level output. RECORD OUT RCA jacks are provided to deliver a line level preamp signal for tape recording convenience.

The rugged 80 watt power amplifier was designed to give years of reliable service under all conditions and is equipped with a unique implementation of our exclusive DELTACOMP™ adaptive compression system. When DELTACOMP™ engages, it is practically impossible to cause the power amplifier to clip (distort). With DELTACOMP™, apparent compressor release time is kept short, yet waveform distortion is kept to a minimum at low frequencies.

The selection of a Fender amplifier will reward you with years of quality music in a wide range of sonic possibilities. This manual is designed to familiarize you with the features and functions of your **KXR 100** amplifier. Read this manual carefully so you will benefit from these features as soon as you start using your new Fender amplifier.

The built-in quality of a Fender amplifier is the result of over four decades of dedication in the combined skills of the Fender design team. That's why we proudly say, *FENDER.. The Sound That Creates Legends.*

KXR 100 Front Panel Functions

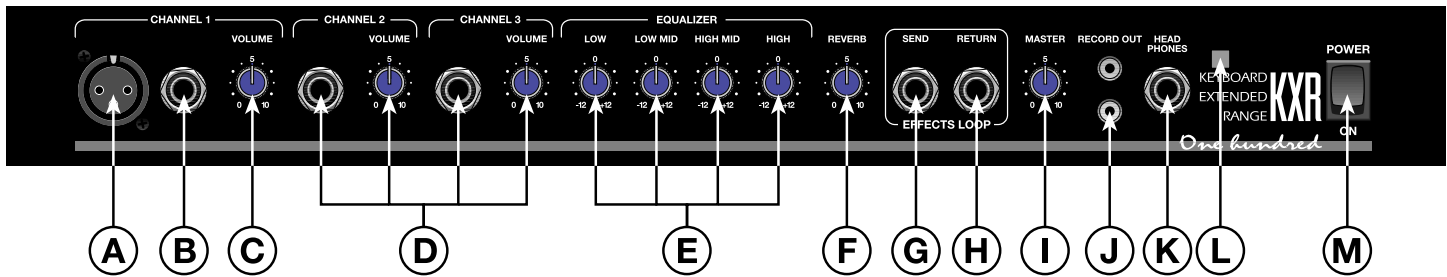

A. Channel 1 Input (XLR)- A high sensitivity, XLR style connector designed for use with microphones. This balanced input can handle as much as 1V R.M.S.

B. Channel 1 Input (Phone)- Plug-in connection for instruments. This balanced input can handle as much as 8V R.M.S.

C. Channel 1 Volume- This control adjusts the preamplifier gain of channel 1. It works in conjunction with the Master Volume control (item 1) to set the overall loudness of the amplifier for channel 1 only. Being a true "gain" control, it allows for the use of a variety of microphones, keyboards or other instruments with differing output signal levels. Low-level instruments generally require a higher Channel Volume setting while "hotter" keyboards will require a lower setting.

D. Channels 2 and 3 - These channels are provided for two additional instruments. The inputs and volume controls operate in the same manner as items B and C in Channel 1. These channels are muted when nothing is plugged into their inputs, and thus will contribute no additional residual noise to the amplifier output when left unused. All three channels may be used simultaneously, however Channel 1 should be used first if only one input is needed.

E. Equalizer- The equalizer allows precise adjustments of the tonal characteristics of the amplifier. Each control provides a 12 dB boost or cut to bands of frequencies centered about 100, 338, 1588, and 4000 Hz.

F. Reverb control- This control adjusts the amount of reverb to be mixed with the dry signal. The input to the reverb circuitry is the sum of channels 1, 2 and 3.

G. Effects Send jack- This jack provides an unbalanced output signal from the preamp. This output can be used with the Effects Return jack (item H) as a patch point for mono effects devices. The Effects Send is connected to the input of the effect (digital delay or other effects device) and the output of the effect is connected to the Effects Return jack (item H). The Effects Send can also be used to provide a signal to a

recording or sound reinforcement mixer. In addition, this output can be used to drive another KXR 100 as a slave amp. This is done by connecting a standard guitar cord from the Effects Send jack of the master amp to the Effects Return jack of the slave amp.

H. Effects Return jack- This balanced jack inputs signal to the Master Volume control, which drives the power amp section. It automatically disconnects the preamp when used. This jack is useful with the effects loop feature, or when using the KXR 100 as a slave amp.

I. Master Volume control- This control adjusts the level of the signal coming out of the preamplifier section. This control is used in conjunction with the Channel Volume controls to set the overall sound level of the amplifier. In order to maximize headroom and minimize noise, instruments with low-level output will require a high Channel Volume setting and a low Master Volume setting, while other instruments may require a lower Channel Volume and higher Master Volume setting. It is recommended that the Master Volume control be set as high as possible for maximum DELTACOMP' compressor range.

J. Record Out jack- Two RCA style jacks provide an unbalanced, mono signal for recording. This signal is derived from the preamp and is at line level, similar to that of the Effects Send jack. The level is not affected by the Master Volume Control.

K. Headphone jack- This jack allows the use of stereo headphones for private listening. When this jack is used, the internal speaker is disconnected. **WARNING: BE CAREFUL WHEN USING HEADPHONES, AS EXCESSIVE VOLUME WILL DAMAGE YOUR HEARING.**

L. Power Indicator- When this LED is illuminated, the KXR 100 is receiving power.

M. Power Switch- This switch turns the KXR 100 on or Off. When the switch is off, the amplifier is completely shut down.

KXR 100 Rear Panel Functions

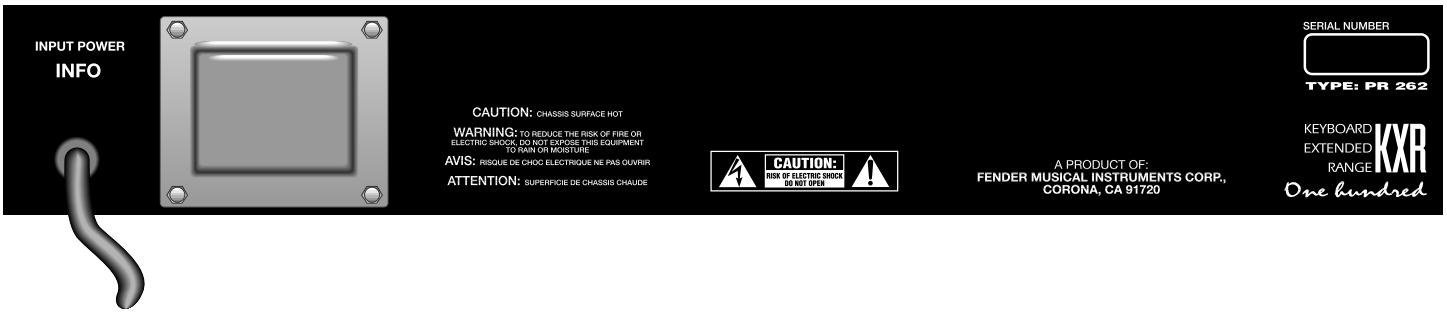

NOTE: DO NOT BLOCK THE AIR FLOW TO THE REAR PANEL; FOR EXAMPLE, BY BACKING THE AMPLIFIER UP AGAINST A WALL. The rear panel is used to keep the output devices from getting too hot.

POWER CORD - This amplifier is equipped with a grounding type supply cord to reduce the possibility of shock hazard. Be sure to connect it to a grounded AC receptacle. The line cord should be connected to a suitable power source, in accordance with the voltage and frequency as shown by the power rating on the rear panel. **DO NOT ALTER THE AC (MAINS) PLUG.**

WARNING: THIS EQUIPMENT MUST BE GROUNDED.

COVERING CARE- The exclusive vinyl covering on your cabinet has been especially designed for years of lasting beauty. A very light, soapy solution on a sponge may be used to remove dirt and residue that may accumulate in the texture. Be careful not to let any liquid come in contact with the operating surfaces. **UNPLUG THE POWER CORD BEFORE CLEANING.**

Troubleshooters Checklist

If the amp is set up but does not function, check the following items:

- Is the amp power cord plugged into an electrical outlet?
- Is there power at the outlet?
- Are all the control knobs turned up?
- Is the volume control on the instrument turned up?
- Is the instrument properly plugged into the amplifier?
(Eliminate any effect pedals and try another guitar cord.)

If, after checking all of the above, the system is still not performing correctly, consult your FENDER Service Dealer.

KXR 100 Specifications

Part Number:	120V Version:	22-8501
	230V Version:	22-8561
Type Specification:	PR 262	
Power Requirements:	100V Version:	100VAC, 50/60 Hz, 360W Max.
	120V Version:	120VAC, 60 Hz 360W Max.
	230V Version:	230VAC, 50 Hz, 360W Max.
	240V Version:	240VAC, 50 Hz, 360W Max.

POWER AMPLIFIER SECTION:

Power output:	80 watts R.M.S.
Rated load impedance:	4 Ohms
Distortion at 80 watts:	Less than .1% @ 1kHz, before compression. less than 1% @ 1kHz, maximum compression.
Sensitivity:	370mV R.M.S.
Input impedance:	33k Ohms
DELTA COMP™ range:	20 db

PREAMP SECTION:

Input impedance:	XLR - 10k Ohms Phone - 36k Ohms
Sensitivity for 80 W: CHANNEL AND MASTER VOLUME at maximum, all tone controls at "0"	XLR - 2.8mV Phone - 28mV
Equalizer:	Low +/- 12 dB @ 100 Hz (shelving) Low Mid +/- 12 dB @ 338 Hz High Mid +/- 12 dB @ 1588 Hz High +/- 12 dB @ 44 Hz (shelving)

PHYSICAL SPECIFICATIONS:

Height:	27-1/2 inches	(69.8 cm)
Width:	20-1/2 inches	(52.1 cm)
Depth:	12 inches	(30.5 cm)
Weight:	55 lbs.	(25 kg)
Speaker:	15" Fender Special Design (P/N 047539) Dual piezo horn (P/N 028813)	

WARNING: NO USER SERVICEABLE PARTS INSIDE. REFER SERVICING TO QUALIFIED PERSONNEL ONLY.
TO PREVENT FIRE OR SHOCK DO NOT EXPOSE THIS EQUIPMENT TO RAIN OR MOISTURE

KXR 100 Block Diagram

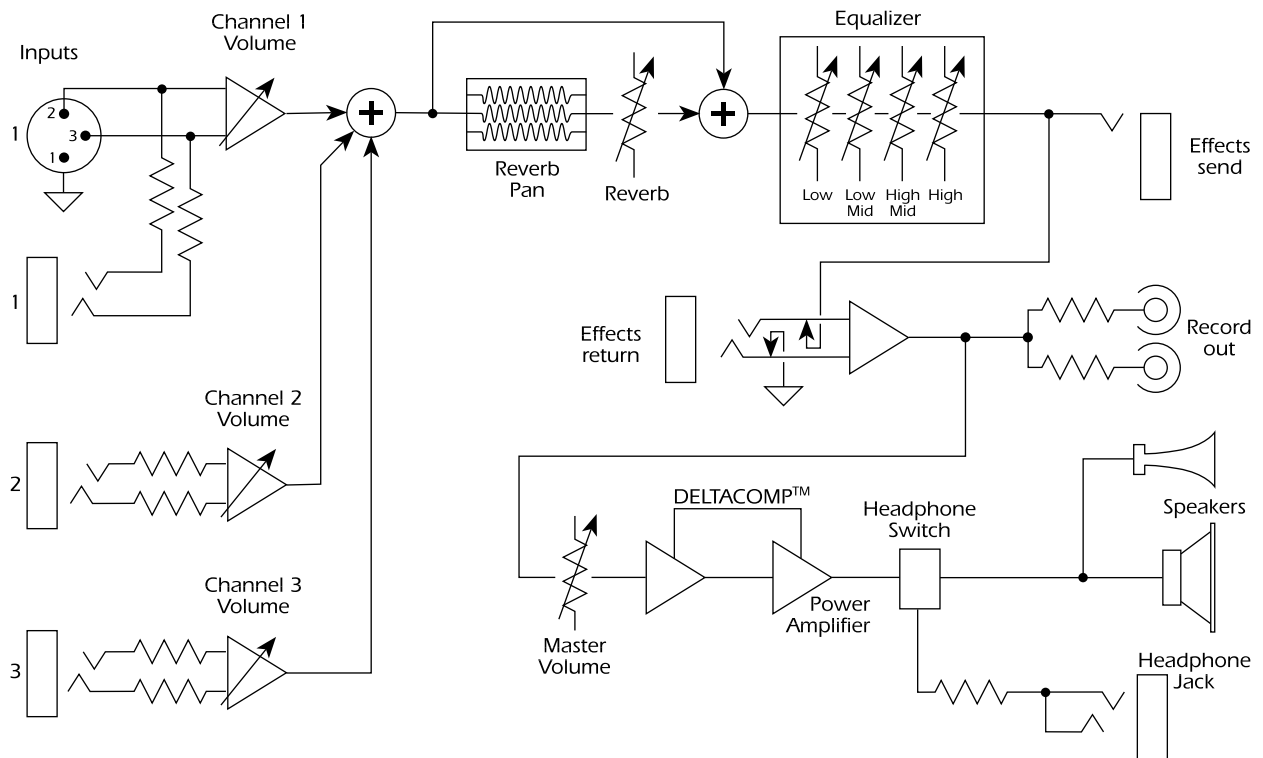

Notes

A PRODUCT OF:
FENDER MUSICAL INSTRUMENTS CORP.,
CORONA, CA 91720

Free Manuals Download Website

<http://myh66.com>

<http://usermanuals.us>

<http://www.somanuals.com>

<http://www.4manuals.cc>

<http://www.manual-lib.com>

<http://www.404manual.com>

<http://www.luxmanual.com>

<http://aubethermostatmanual.com>

Golf course search by state

<http://golfingnear.com>

Email search by domain

<http://emailbydomain.com>

Auto manuals search

<http://auto.somanuals.com>

TV manuals search

<http://tv.somanuals.com>