

Fender®

MADE IN U.S.A.

SRA 200 STEREO POWER AMPLIFIER (Professional Sound Reinforcement Amplifier)

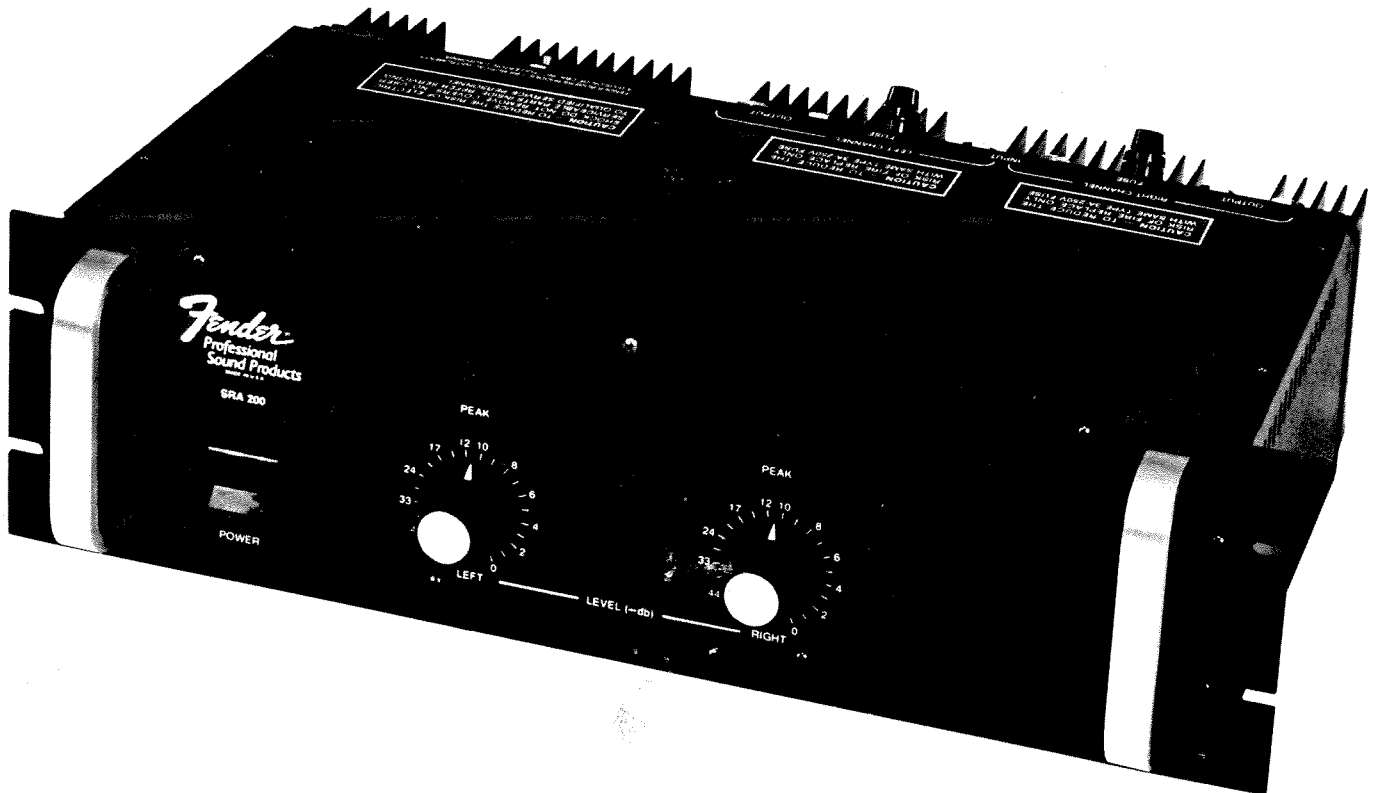

OPERATION INSTRUCTION MANUAL

MANUAL NO. 017055

WARNING
TO REDUCE THE RISK OF FIRE
OR SHOCK HAZARD, DO NOT
EXPOSE THIS APPLIANCE TO
RAIN OR MOISTURE

SRA 200
STEREO POWER AMPLIFIER
OPERATION INSTRUCTION MANUAL

BY

Fender[®]
MADE IN U.S.A.

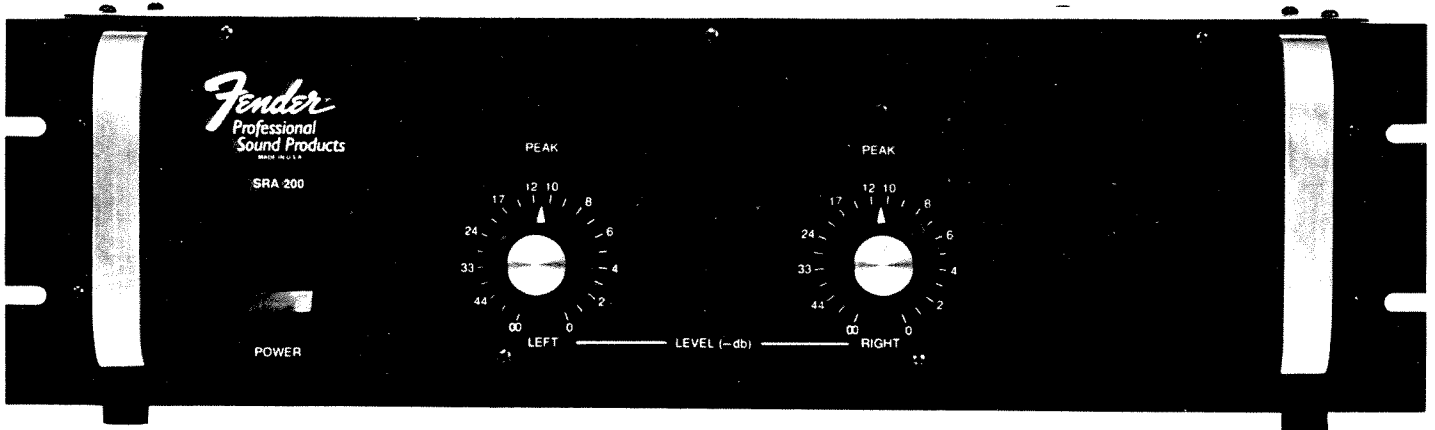

PHYSICAL DIMENSIONS (APPROXIMATE, FOR SHIPPING PURPOSES)

	U.S. System	Metric System
Weight	25 pounds	11.3 kg
Width	19 inches	48.3 cm
Depth	11.4 inches	29.8 cm
Height	5.25 inches	13.3 cm

P.O. BOX 4137 • 1300 EAST VALENCIA DRIVE • FULLERTON, CALIFORNIA 92634

NOTE: See accompanying limited warranty folder.

TABLE OF CONTENTS

	PAGE		PAGE
Introduction	iii	SECTION II	
SECTION I		SETTING UP THE SYSTEM	3
SRA 200 FRONT PANEL	1	Sound System Connections	3
Input Attenuators	1	Speaker Placement	3
LED Peak Indicators	1	Speaker Connection	3
Power Switch	1	Stereo Program Connection	3
SRA 200 REAR PANEL	1	Monophonic Connection	4
Right Channel Output Jacks	1	Monophonic/Monitor Connection	4
Left Channel Output Jacks	1	Stereo Bi-Amplified Connection	4
Fuses	1	Stereo Bi-Amplified Connection #2	4
Right Channel Input Jacks	2	Monophonic Bi-Amplified Connection	4
Left Channel Input Jacks	2	SECTION III	
Circuit Breaker	2	Sound System Block Diagrams	5-7
Line Cord Receptacle	2	Preliminary Operating Sequence	8
Voltage Selector Switch	2	SRA 200 General Specifications	9

LIST OF FIGURES

FIGURE	DESCRIPTION	PAGE
1	Front Panel Functions	1
2	Rear Panel Connections	2
3	Typical Stage Setup	3
4	Typical Stereo Program Connection	5
5	Two Channel Output From Single Source (Monophonic)	5
6	Monophonic Program/Monitor Connection	6
7	Stereo Bi-Amplified Connection	6
8	Stereo Bi-Amplified Connection #2	7
9	Monophonic Bi-Amplified Connection	7

INTRODUCTION

The Fender SRA 200 is a 100 watts per channel solid state Stereo power amplifier designed for sound reinforcement applications. It is designed for standard 19" rack mounting and is ruggedly constructed to withstand the physical abuse often encountered in road travel. Unique fast acting LED Indicators show the operator when actual clipping occurs, rather than simply indicating a near-clipping level. In addition, they inform the operator when the unit is operating with large amounts of slew-induced distortion present in the output. The SRA 200 incorporates detented input attenuators with 22 steps calibrated in dB. These input attenuators allow for predictable and repeatable set-ups, accurate input sensitivity adjustments, and precise channel tracking. Each channel employs a FET controlled turn-on/turn-off muting circuit, a low noise/high slew rate operational amplifier, and four rugged NPN output transistors mounted on conservatively designed heatsinks.

The SRA 200 features protective circuits such as output transistor thermal cutout, fast action speaker fuses, power transformer thermal cutout, and primary circuit breaker, making it practically abuse proof. The following pages of this manual detail the functions of the various controls and jacks, and use of the SRA 200 in a professional sound system.

BEFORE ATTEMPTING TO USE THE UNIT, FAMILIARIZE YOURSELF WITH THE INFORMATION CONTAINED IN THIS MANUAL.

SECTION I

SRA 200 FRONT AND REAR PANELS

SRA 200 FRONT PANEL

Input Attenuators (Fig. 1 - Item 1)

These calibrated stepped Input Attenuators lower input signal levels to their respective channels ahead of amplification stages.

LED Peak Indicators (Fig. 1 - Item 2)

These LED Indicators glow red when the corresponding power amplifier output channel is distorting due to clipping or to slew induced distortion.

Power Switch (Fig. 1 - Item 3)

This switch controls AC power to the SRA 200 unit. The internal switch lamp glows red when the power is turned on.

SRA 200 REAR PANEL

Right Channel Output Jacks (Fig. 2 - Item 1)

Left Channel Output Jacks (Fig. 2 - Item 2)

Each pair of these phone jacks is wired in parallel and serves to connect each speaker enclosure to its respective output channel. Total impedance of the speakers in each channel should not be less than 8 ohms.

Fuses (Fig. 2 - Item 3)

These fuses are connected in series with their respective speaker jacks. They protect the speakers in the event of amplifier failure, and prevent damage to the amplifier caused by driving low impedance loads. Each fuse is rated at 3 amperes and should be replaced only with one of the same rating and type.

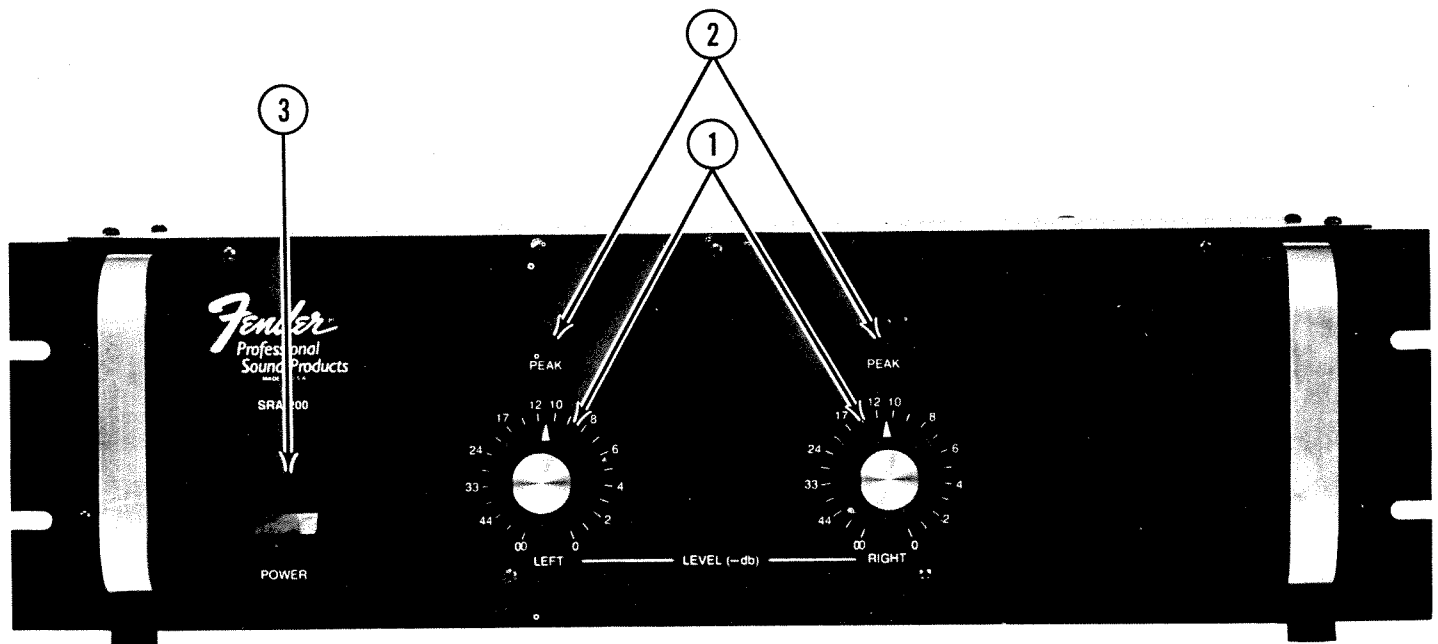

FIGURE 1 — Front Panel

Right Channel Input (Fig. 2 - Item 4)

Left Channel Input (Fig. 2 - Item 5)

These phone jacks on each channel are unbalanced and are used to connect an external signal such as that from the output of a mixer, to the respective power amplifier input channel (input impedance 33K ohms). If only the right channel input jack is used, the left channel input jack is automatically fed the right channel's input information, via an internal switch. This feature is very beneficial in monophonic sound applications. (See Sound System Connections).

Circuit Breaker (Fig. 2 - Item 6)

This Circuit Breaker provides protection in the event of internal amplifier failure. The breaker is reset by pushing in the red button.

Line Cord Receptacle (Fig. 2 - Item 7)

This receptacle provides connection for the detachable power cord.

Voltage Selector Switch (Fig. 2 - Item 8)
(Export version only)

This switch allows selection of the following 50 or 60 Hz AC line voltages:

100 — 120 — 127 — 220 — 240 — 260.

Always turn OFF the power switch (Figure 1 - Item 3) before making line voltage changes. Selection should be made only to the proper AC line voltage for your area.

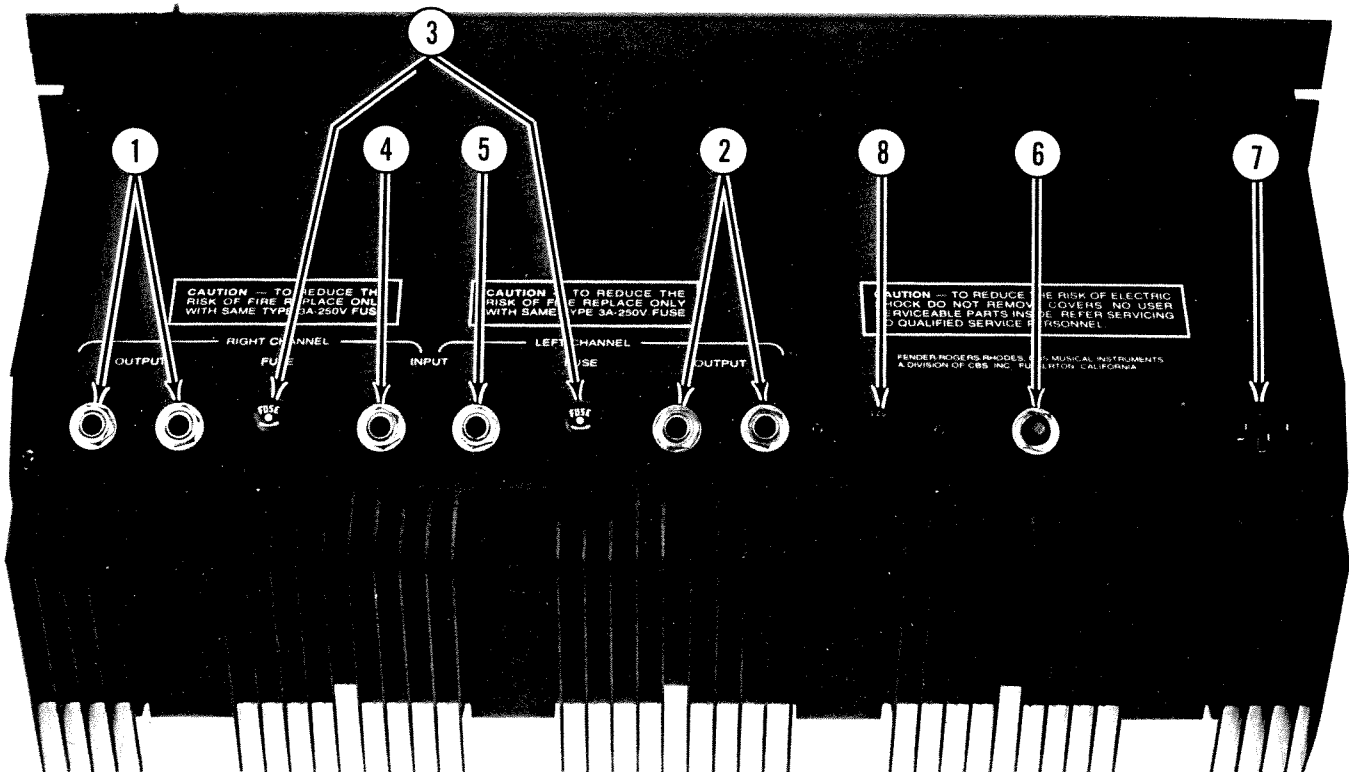

FIGURE 2 — Rear Panel

SECTION II

SETTING UP THE SYSTEM

SOUND SYSTEM CONNECTIONS

The SRA 200 is a stereo (two channel) amplifier and special care must be taken in setting it up. The unit contains two channels of power amplification, and offers some special connections which may be advantageous under certain conditions. The normal set-up and some of the special connections are detailed in this section.

Speaker Placement (Fig. 3)

In order to minimize feedback in a typical stage set-up the speakers should be placed forward of the microphones. The speakers should be used in their normal up-right position (not turned on their sides) in order to take advantage of their inherent directional quality.

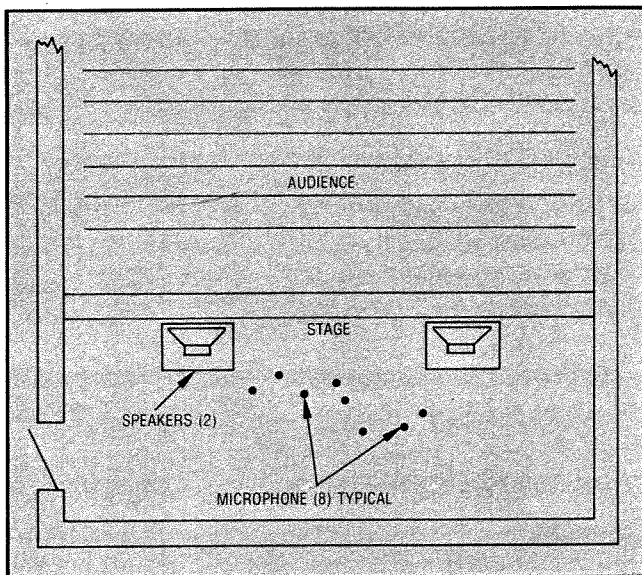

FIGURE 3 — Typical Stage Setup

SPEAKER CONNECTION

Each output channel of the SRA 200 is designed for a minimum total load impedance of 8 ohms. If the total impedance of the speakers on either channel output is less than 8 ohms the amplifier may be overloaded and cause the corresponding channel's speaker fuse to blow. For example; at high volume, overload might occur if two 8 ohm speakers were plugged into one channel's pair of output jacks (a parallel connection resulting in a load impedance of 4 ohms), or, if only one 4 ohm speaker were used. Connect the speakers to the power amplifier using #18 AWG or larger unshielded wire. "Zip Cord" is suitable for this purpose. For long runs of speaker cable (over 25 feet), #16 AWG or larger wire is recommended. While use of a shielded guitar cable to connect the speakers will not damage the equipment, a loss of volume or damage to the shielded cable may result. Choose only high quality ¼" phone plugs, and check the cables for possible short-circuits; an internal short-circuit or a cracked phone plug insulator might blow a fuse in the power amplifier.

Stereo Program Connection (Fig. 4)

The conventional stereo program system setup is illustrated in Figure 4. In this connection the program outputs of a conventional stereo mixer are fed to the corresponding channel inputs of the SRA 200. Channel outputs of the SRA 200 are then connected to their corresponding speakers. The speaker on the left side of the stage should be connected to one of the left speaker output jacks on the back of the amplifier.

The speaker on the right side should be connected to one of the right speaker output jacks.

Monophonic Connection (Fig. 5)

This shows how a monophonic signal source such as one program channel of a mixer, can be used to drive both channels of the SRA 200 power amplifier in monophonic mode. When a monophonic source is connected to the right channel input jack, the left channel input jack is automatically fed the right channel's input information via an internal switch.

Monophonic/Monitor Connection (Fig. 6)

This diagram shows that if stereo program output is not necessary, one channel of power amplification in the SRA 200 may be allocated to the program material, and the other to the monitor material. In the case illustrated, the left channel has been allocated to the program material, and the right channel has been assigned to the monitor material.

Stereo Bi-Amplified Connection (Fig. 7)

A bi-amplified system can provide increased headroom, efficiency, damping factor, and decreased distortion. The SRA 200 Power Amplifier can be incorporated in bi-amplified sound systems to realize these advantages. This diagram shows the left and right program mixes fed to a two channel electronic crossover, where each channel is frequency-divided into low frequencies and high frequencies. The left program channel's low frequency material is fed to the SRA 200 right channel input, while the left program channel's high frequency material is fed to the SRA 200 left channel input.

The SRA 200 left channel output is connected to the high frequency driver (tweeter) of the left bi-amplified speaker. The SRA 200 right channel output is connected to the low frequency driver (woofer) of the left bi-amplified speaker. Similarly, the right program channel's material is processed and eventually amplified by an additional stereo power amplifier and fed to a right bi-amplified speaker.

Stereo Bi-Amplified Connection #2 (Fig. 8)

This diagram shows a second bi-amp scheme that is widely used. In this stereo system one power amplifier is used to amplify only the highs, and another amplifier to process the lows. In most popular music low frequency material contains considerably more energy than high frequency material, and most sound reinforcement speaker systems have high frequency drivers which have greater efficiencies than their associated low frequency drivers. As a result, the power amplifier chosen to amplify the high frequency material need NOT be as powerful as the one chosen to amplify the low frequency material. In the system shown in Figure 8, the SRA 200 was chosen as the low frequency amplifier.

Monophonic Bi-Amplified Connection (Fig. 9)

This diagram shows how the SRA 200 can also be used independently in a monophonic bi-amplified system.

SECTION III

SRA 200 STEREO POWER AMPLIFIER

SOUND SYSTEM CONNECTIONS

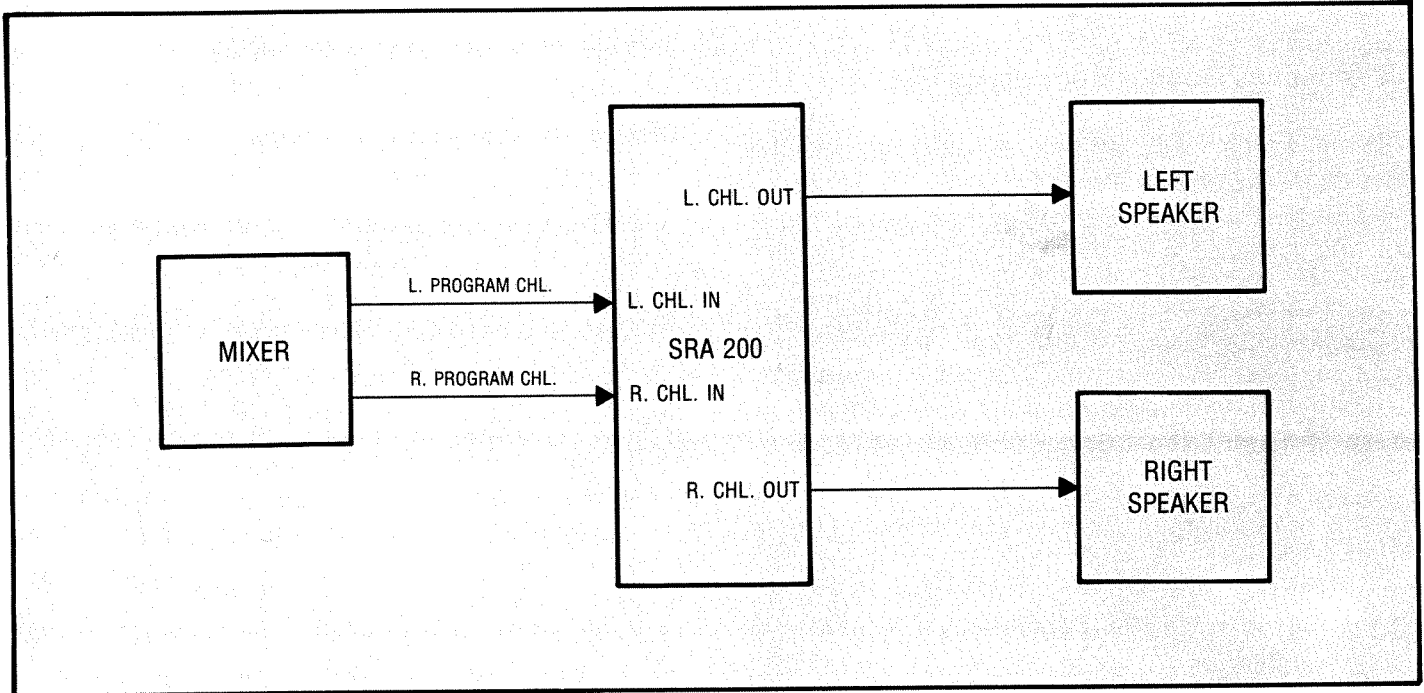

FIGURE 4 — Typical Stereo Program Connection

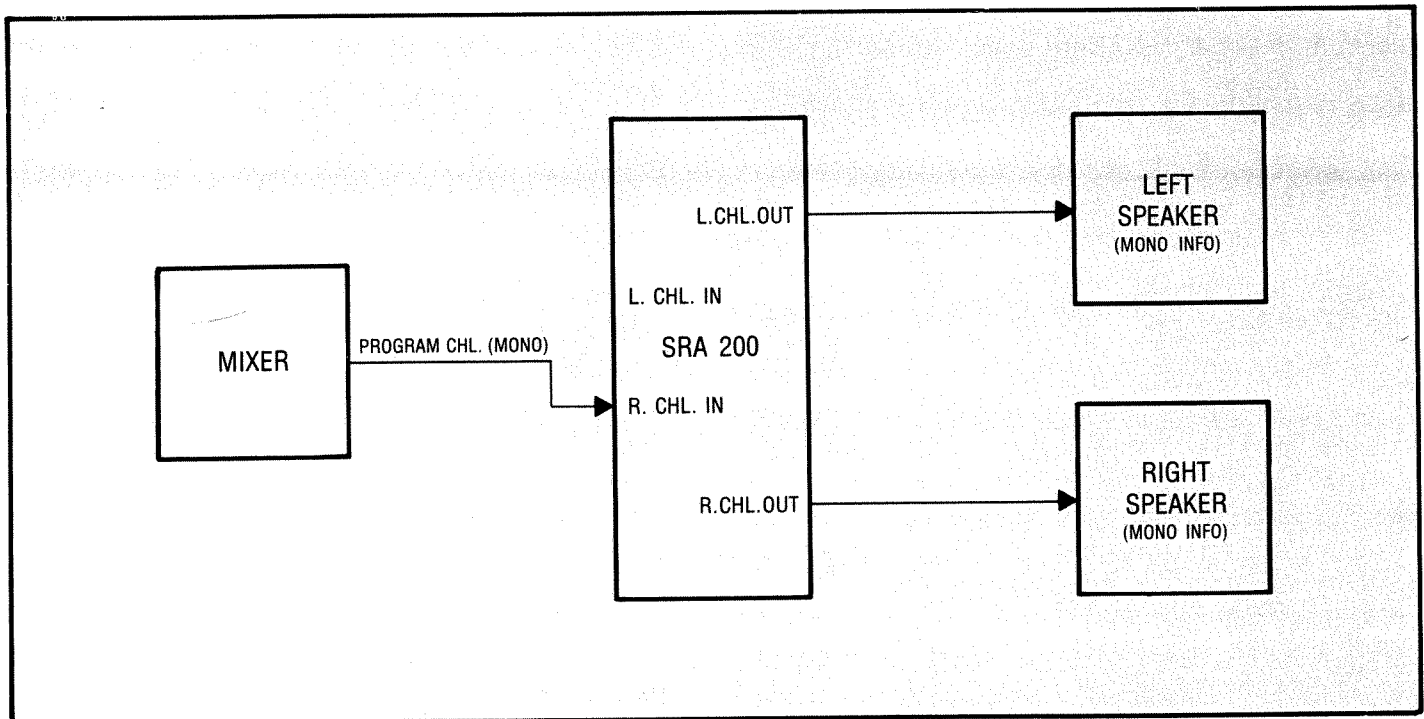

FIGURE 5 — Two Channel Output From Single Source (Monophonic)

SRA 200 STEREO POWER AMPLIFIER SOUND SYSTEM CONNECTIONS

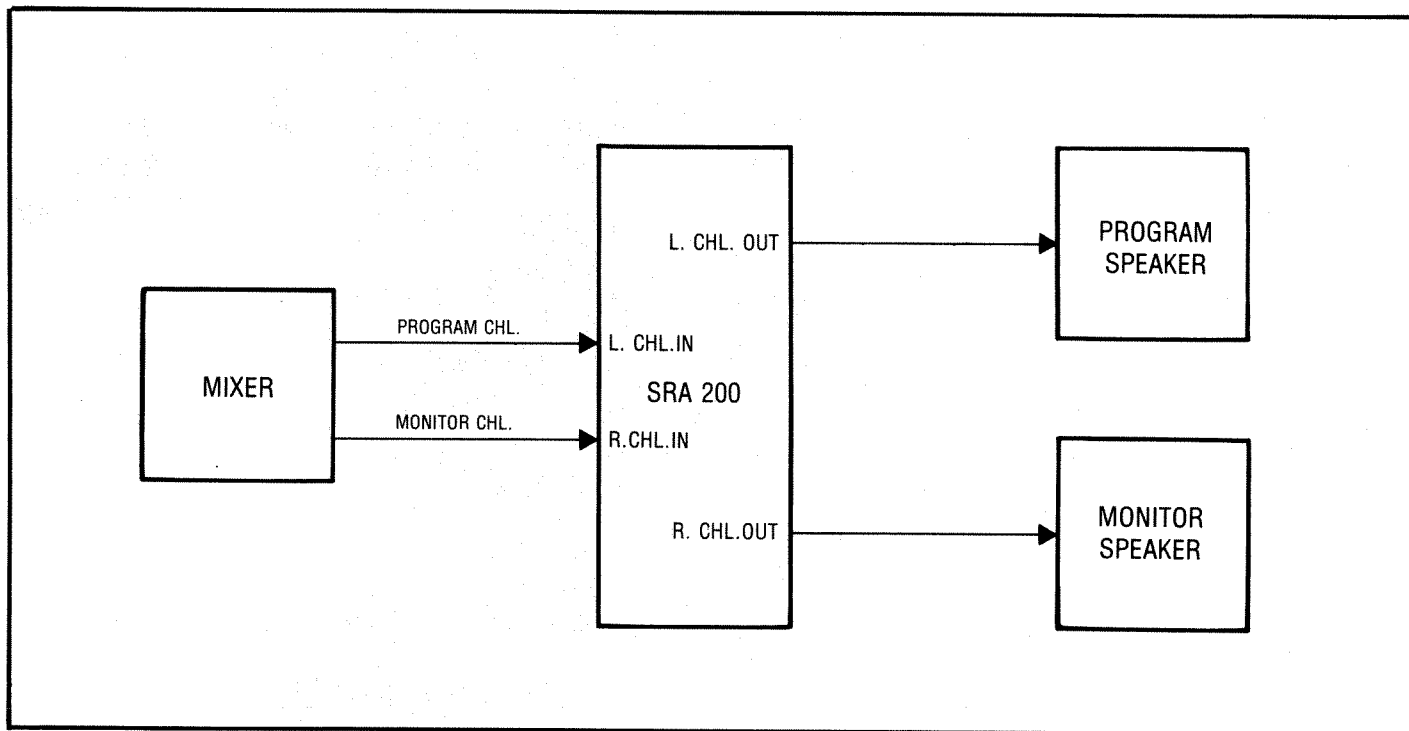

FIGURE 6 — Monophonic Program/Monitor Connection

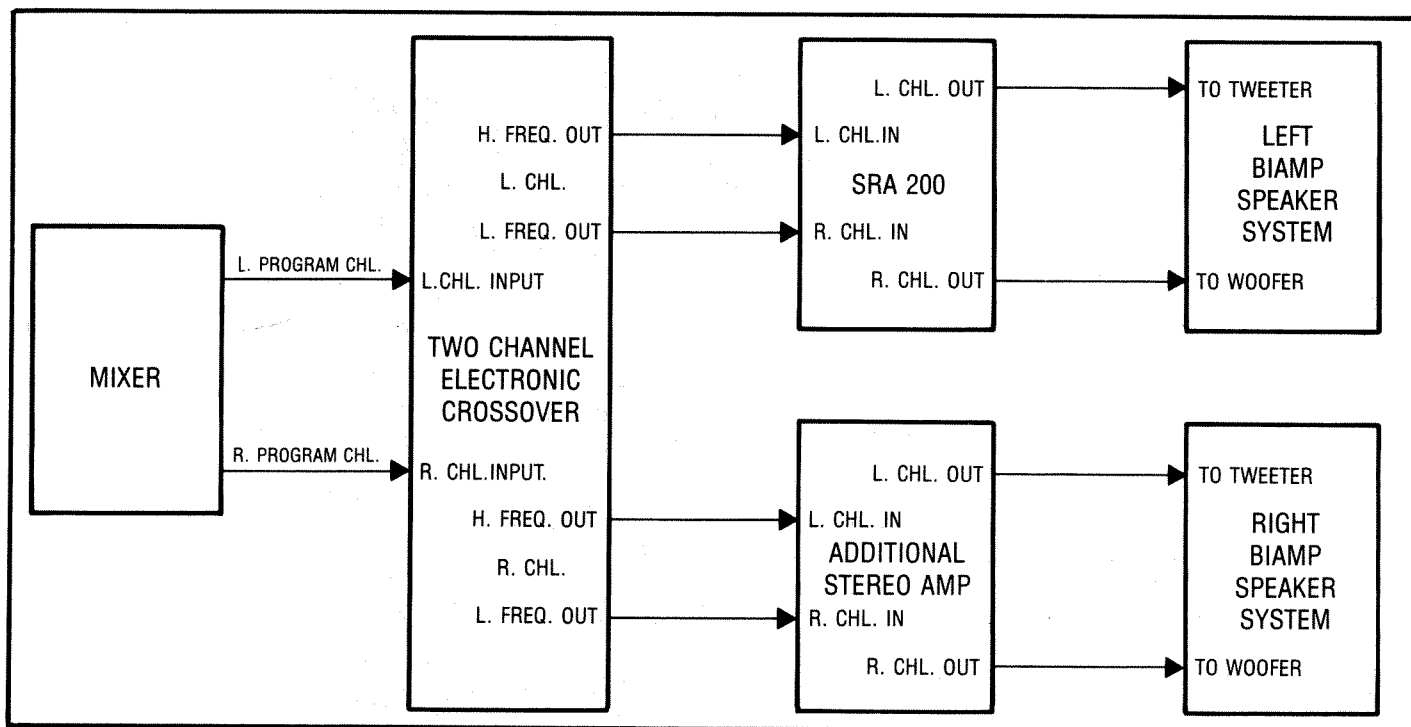

FIGURE 7 — Stereo Bi-Amplified Connection #—1

SRA 200 STEREO POWER AMPLIFIER SOUND SYSTEM CONNECTIONS

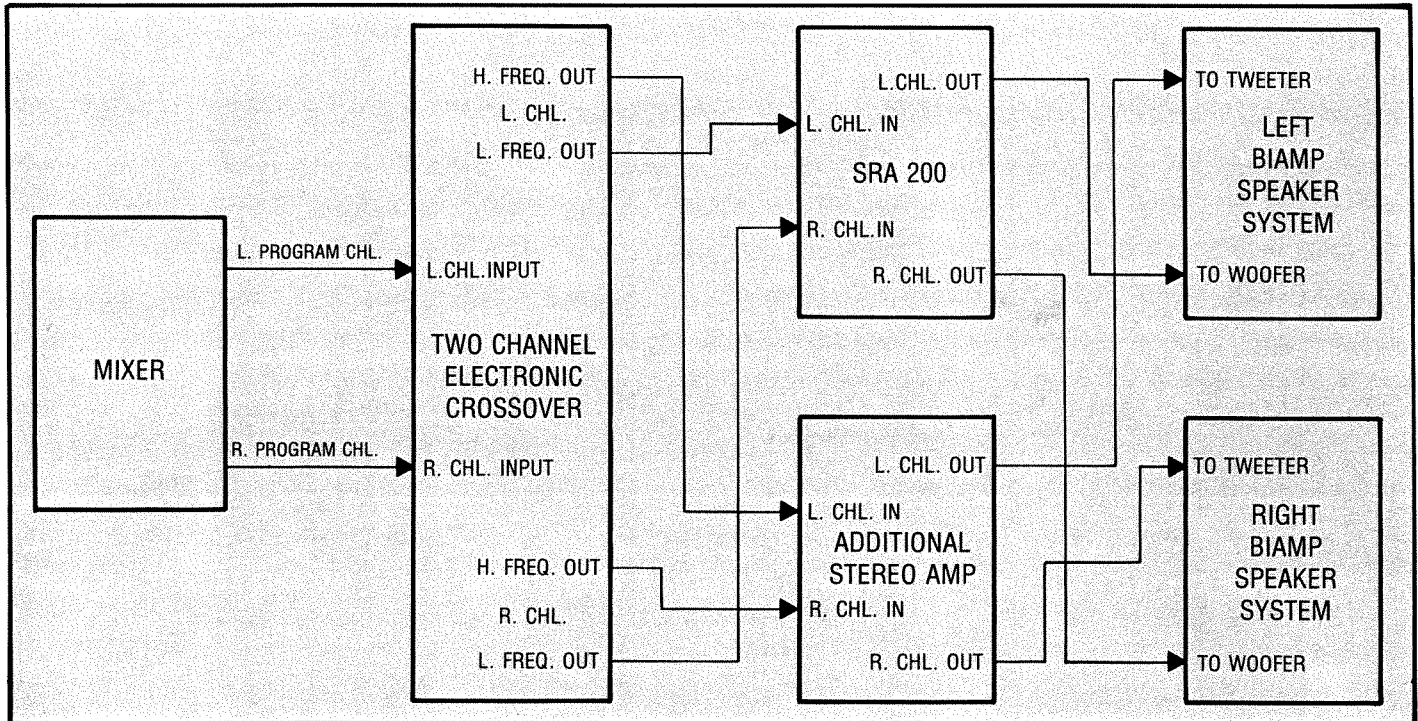

FIGURE 8 — Stereo Bi-Amplified Connection #—2

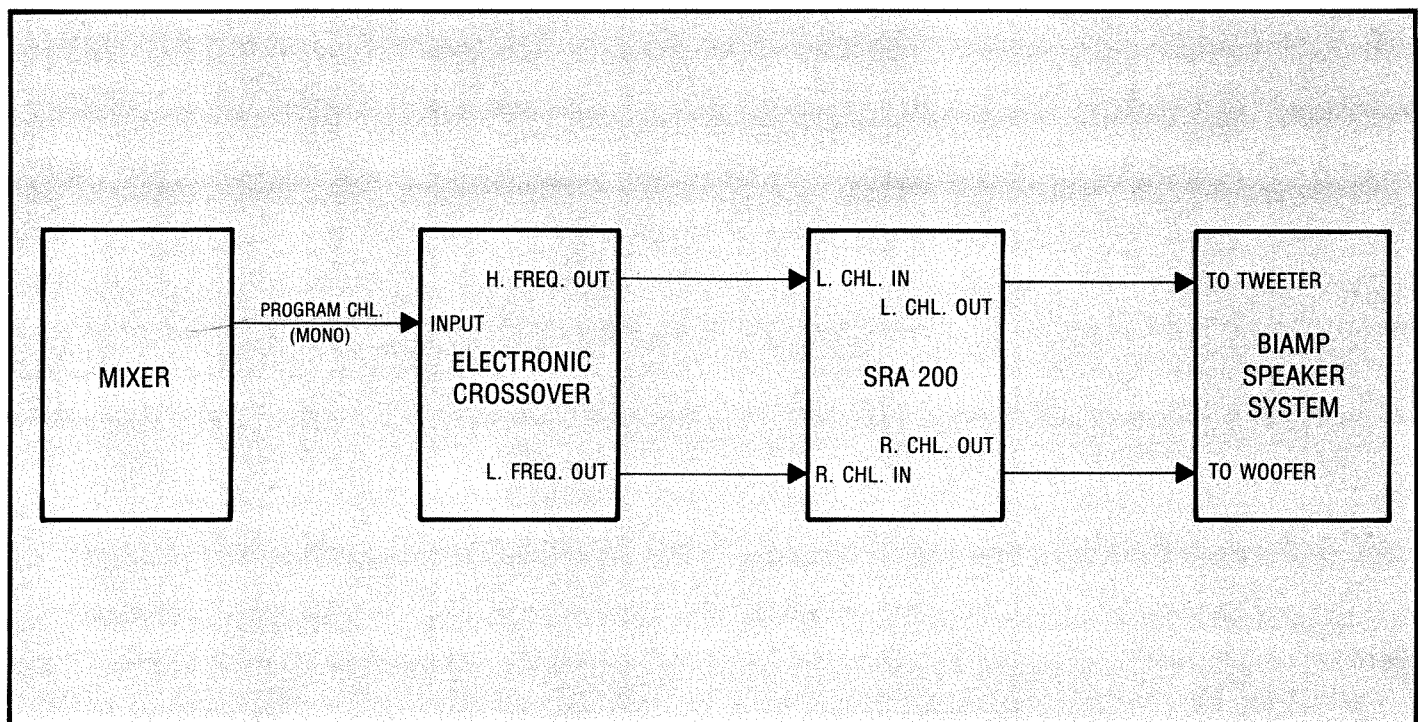

FIGURE 9 — Monophonic Bi-Amplified Connection

PRELIMINARY OPERATING SEQUENCE

NOTE: If the SRA 200 is to be rack-mounted, care should be taken to position it so that the fuse-holders and AC line cord do NOT interfere with the unit mounted directly above it. This can be prevented if a unit of less depth than the SRA 200, or a spacing panel is mounted above it.

1. Connect the sound system required for your specific application. (See Sound System Connections pp. 5-7).
2. Turn on the sound system's mixer and adjust per owner's manual to proper program and monitor level outputs.
3. Set both channel input attenuators (Fig. 1 - Item 1) to their minimum level position (∞).
4. Plug the power cord (supplied) into the line cord receptacle located on the rear panel (Fig. 2 - Item 7). Do NOT remove the grounding prong on the AC plug, it prevents hum and possible shock. If necessary, use a three-prong to two-prong adapter.
5. Turn the power switch on (Fig. 1 - Item 3). The switch's internal lamp will light up. If it does not, check the power cord connection and the circuit breaker (Fig. 2 - Item 6).
6. Adjust the volume level with the channel input attenuators. Maximum permissible volume is reached when the LED peak indicators (Fig. 1 - Item 2) begin to flicker. Beyond this point, audible distortion and blown fuses may result.

GENERAL SPECIFICATIONS

Power Output per Channel:	100 watts continuous average sine wave power into 8 ohms with .007% THD, at 1 kHz, both channels driven. 90 watts continuous average sine wave power into 8 ohms with 0.2% THD, over a bandwidth of 20 Hz to 20 kHz, both channels driven.
Frequency Response:	+0. -0.7 dB (20 Hz — 20 kHz) +0. -3.0 dB (10 Hz — 60 kHz)
Total Harmonic Distortion:	.007% at 100 watts, 8 ohms, 1 kHz 0.2% at 90 watts, 8 ohms, (20 Hz to 20 kHz)
Intermodulation Distortion:	.008% using frequencies of 60 Hz and 7 kHz, mixed in a ratio of 4:1 single channel power output of 100 watts into 8 ohms.
Input Sensitivity:	An input of 1.28 VRMS produces an output of 100 watts into 8 ohms. Input attenuator set for maximum level.
Input Impedance:	33 K (input attenuator at max level, stereo operation). 50 K (input attenuator at min level, stereo operation).
Hum and Noise:	102 dB signal to noise ratio. Unweighted measurement reference to full power output (100 W into 8Ω).
Power Requirements:	120 volts AC nominal, 50-60 Hz (108 VAC minimum, 132 VAC maximum) 350 volt-amperes maximum at 120 V. Approximately 30 volt-amperes at idle.
Speaker Fuses:	3 A, 250 V quick acting (Littlefuse Cat. No. 312003 or equivalent).

"SPECIFICATIONS SUBJECT TO CHANGE WITHOUT NOTICE"

NOTE: SEE ACCOMPANYING LIMITED WARRANTY FOLDER



P.O. BOX 4137 • 1300 EAST VALENCIA DRIVE • FULLERTON, CALIFORNIA 92634

Free Manuals Download Website

<http://myh66.com>

<http://usermanuals.us>

<http://www.somanuals.com>

<http://www.4manuals.cc>

<http://www.manual-lib.com>

<http://www.404manual.com>

<http://www.luxmanual.com>

<http://aubethermostatmanual.com>

Golf course search by state

<http://golfingnear.com>

Email search by domain

<http://emailbydomain.com>

Auto manuals search

<http://auto.somanuals.com>

TV manuals search

<http://tv.somanuals.com>