



A Sierra Monitor Company

Driver Manual
(Supplement to the FieldServer Instruction Manual)

FS-8700-17 Optomux

APPLICABILITY & EFFECTIVITY

Effective for all systems manufactured after January 1, 1999

Instruction Manual Part Number FS-8700-01
--

2/18/2004

Rev: 1.2

TABLE OF CONTENTS

1	Optomux Driver Description.....	1
1.1	Operating Methods	1
1.2	Statistics and Command Responses	1
2	Driver Scope of Supply	2
2.1	Supplied by FieldServer Technologies for this driver	2
2.2	Provided by user.....	2
3	Hardware Connections	3
4	Configuring the FieldServer as a Optomux Driver Client.....	4
4.1	Data Arrays.....	4
4.2	Client Side Connections	5
4.3	Client Side Nodes.....	5
4.4	Client Side Map Descriptors	6
4.4.1	FieldServer Related Map Descriptor Parameters	6
4.4.2	Driver Related Map Descriptor Parameters	7
4.4.3	Timing Parameters	9
4.4.4	Map Descriptor Example 1 – Read on/off Status	10
4.4.5	Map Descriptor Example 2 – Read On/Off Status (Data stored differently)	11
4.4.6	Map Descriptor Example 3 – Command Response/Completion Status	12
4.4.7	Map Descriptor Example 4 – Triggered Action	13
4.4.8	Map Descriptor Example 5 – Using Address and Length to tell the FieldServer which module positions to access.....	14
4.4.9	Map Descriptor Example 6 – Using a Mask to Address specific module positions	15
4.4.10	Map Descriptor Example 7 – Specifying Module Positions Dynamically	16
5	Configuring the FieldServer as a Optomux Server.....	17
6	Driver Notes	18
6.1	Data_Array_Name, DA_Bit_Name, DA_Byte_Name	18
6.2	Module Positions	18
6.3	Command Response Status.....	18
6.4	Optomux Commands.....	19
6.5	Driver Stats	25

1 Optomux Driver Description

The Optomux Driver allows the FieldServer to transfer data to and from devices over either RS-232 or RS-485 using the Optomux Driver protocol.

The Optomux driver is a client only driver. This means that the driver can poll an Optomux protocol compliant device but cannot emulate one.

The Optomux protocol provides a large command set. Many of the commands are used for OPTO22 device configuration. This driver supports the full command set and thus the driver may be used to configure as well as to poll OPTO22 devices.

1.1 Operating Methods

The Optomux driver provides three methods of operation. Users may use any combination of methods.

Static Operation

If the hardware configuration is fixed and known then this is a suitable method. The devices to be polled / commanded are configured using the FieldServer CSV file.

Dynamic Operation

If the hardware configuration may change or if hardware settings may change dynamically or (more realistically) if you wish to change some aspect of the hardware configuration such as a delay time or reset a latch without changing the CSV file and resetting the FieldServer then this operating method is suitable. The commands set can be configured by changing the values in the FieldServer's data arrays. This operating mode may be considered a data driven one.

Triggered Operation

This operating mode allows commands to be triggered by changing the value in the FieldServer's data arrays. This operating mode is useful if requiring an action triggered by a remote device.

1.2 Statistics and Command Responses

All FieldServer drivers report communication statistics that allow the operation of the driver to be monitored.

In addition to the standard statistics, this driver exposes the communication statistics for each port by presenting them in a user specified data array where they can be monitored by a remote device or HMI system.

The Optomux driver also exposes the response status to each poll and command (if required) by writing the response statuses to a user specified data array. This useful feature allows remote devices to check whether a command has been completed successfully.

2 Driver Scope of Supply

2.1 Supplied by FieldServer Technologies for this driver

Driver Manual.

2.2 Provided by user

Optomux System

3 Hardware Connections

The FieldServer is connected to the OPTO22 device as shown below. Configure the OPTO22 device according to manufacturer's instructions.

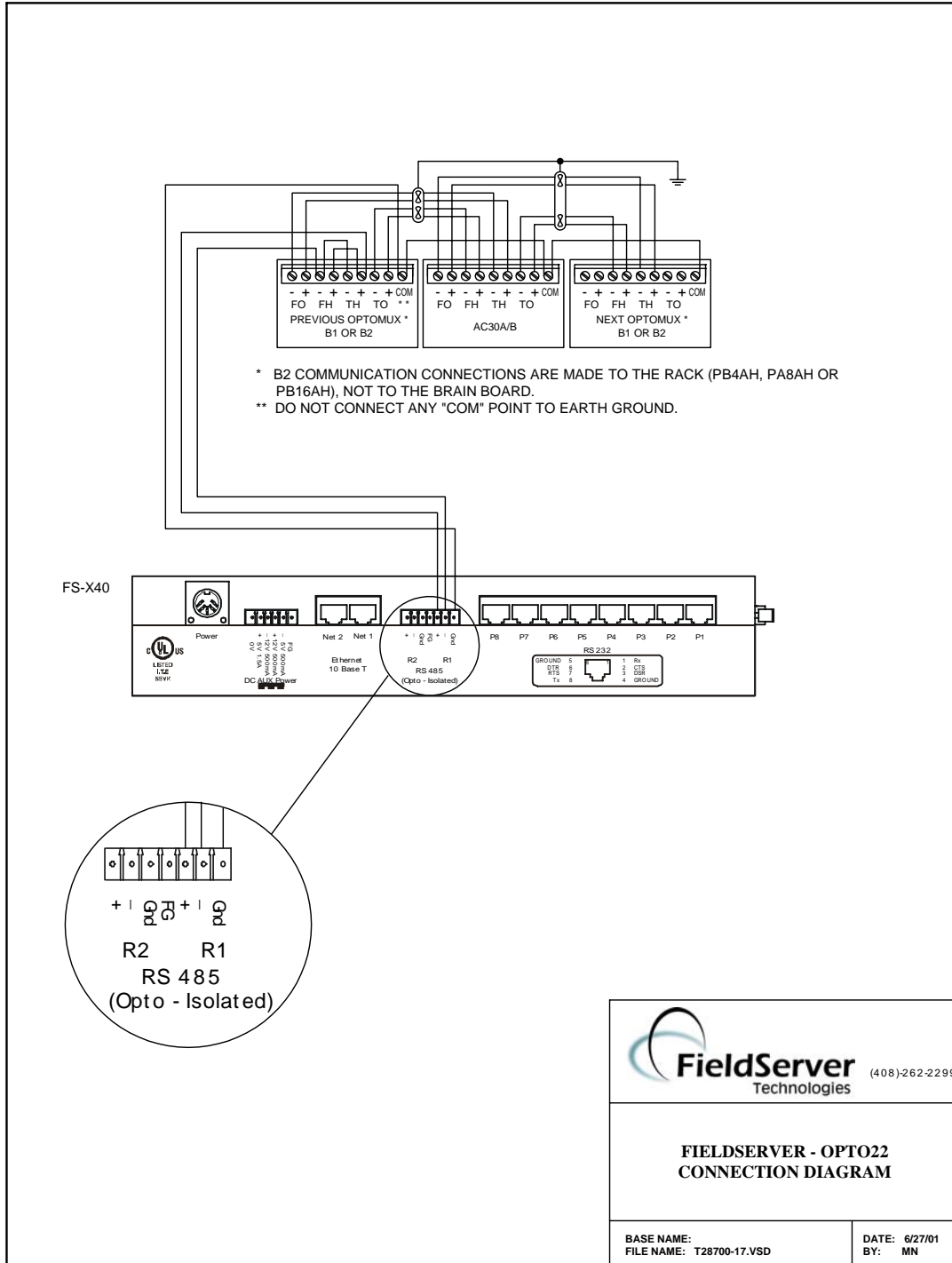

4 Configuring the FieldServer as a Optomux Driver Client

For a detailed discussion on FieldServer configuration, please refer to the FieldServer Configuration Manual. The information that follows describes how to expand upon the factory defaults provided in the configuration files included with the FieldServer (See “.csv” files on the driver diskette).

This section documents and describes the parameters necessary for configuring the FieldServer to communicate with an Optomux Device.

The configuration file tells the FieldServer about its interfaces, and the routing of data required. In order to enable the FieldServer for Optomux Driver communications, the driver independent FieldServer buffers need to be declared in the “Data Arrays” section, the destination device addresses need to be declared in the “Client Side Nodes” section, and the data required from the servers needs to be mapped in the “Client Side Map Descriptors” section. Details on how to do this can be found below.

Note that in the tables, * indicates an optional parameter, with the bold legal value being the default.

4.1 Data Arrays

Section Title		
Data_Arrays		
Column Title	Function	Legal Values
Data_Array_Name	Provide name for Data Array	Up to 15 alphanumeric characters
Data_Format	Provide data format. Each data array can only take on one format.	FLOAT, BIT, UInt16, SInt16, Packed_Bit, Byte, Packed_Byte, Swapped_Byte
Data_Array_Length	Number of Data Objects. Must be larger than the data storage area required for the data being placed in this array.	1-10,000

Example

```

//      Data Arrays
//
Data_Arrays
Data_Array_Name,      Data_Format,      Data_Array_Length
DA_AI_01,             UInt16,           200
DA_AO_01,             UInt16,           200
DA_DI_01,             Bit,              200
DA_DO_01,             Bit,              200
    
```

4.2 Client Side Connections

Section Title		
Connections		
Column Title	Function	Legal Values
Port	Specify which port the device is connected to the FieldServer	R1-R2, (FS-X40 Series) R1 (FS-X20 Series)
Baud*	Specify baud rate	110 – 115200, standard baud rates only At the time of publication of this manual the OPTO22 device's support standard baud Rates in the range 300-38400.
Parity*	Specify parity	Even, Odd, None , Mark, Space
Data_Bits*	Specify data bits	7, 8
Stop_Bits*	Specify stop bits	1
Protocol	Specify protocol used	Optomux
Handshaking*	Specify hardware handshaking	RTS, RTS/CTS, None
Poll Delay*	Time between internal polls	0-32000 seconds default 1 second

Example

```
// Client Side Connections

Connections
Port, Baud, Parity, Protocol, Handshaking, Poll_Delay
R1, 9600, None, Opto22, None, 0.100s
```

4.3 Client Side Nodes

Section Title		
Nodes		
Column Title	Function	Legal Values
Node_Name	Provide name for node	Up to 32 alphanumeric characters
Node_ID	OPTO22 device address.	0-255
Protocol	Specify protocol used	Optomux
Port	Specify which port the device is connected to the FieldServer	R1-R2, (P1-P8 with a converter)

Example

```
// Client Side Nodes

Nodes
Node_Name, Node_ID, Protocol, Port
Optomux1, 1, Optomux, R1
```

4.4 Client Side Map Descriptors

4.4.1 FieldServer Related Map Descriptor Parameters

Column Title	Function	Legal Values
Map_Descriptor_Name	Name of this Map Descriptor	Up to 32 alphanumeric characters
Data_Array_Name	<p>Name of Data Array where data is to be stored / retrieved in the FieldServer.</p> <p>The use of this array is dependent on the Optomux command used in the map descriptor.</p> <p>For example some commands use one data value for all module positions to be affected by the command (Driver will only use one data array element). Other commands may use one data element per module position specified. In this case the FieldServer may use up to 16 data array elements.</p> <p>To fully understand this, read the notes in chapter 6.</p>	One of the Data Array names from "Data Array" section above
Da_Bit_Name*	<p>This parameter is only required for dynamic module position specification. I.e. You intend using a data array to tell the driver which module positions to affect by a command. In this case use this parameter. Up to 16 elements will be inspected. The first element will always be used for the first module position , the 2nd element for the 2nd module position</p> <p>Module positions are specified by setting the corresponding array element to a non-zero value. Module positions are left unspecified by setting the module array position to zero.</p> <p>The first element of this array that is used is determined by the Data_Array_Offset parameter.</p> <p>Additional information is provided in chapter 6.</p>	One of the Data Array names from "Data Array" section above

Da_Byte_Name*	Names a data array that the driver will use to store poll/query response status data. One data element is used per map descriptor. The element is determined by the Data_Array_Offset parameter.	One of the Data Array names from "Data Array" section above
Data_Array_Offset	Starting location in Data Array	0 to maximum specified in "Data Array" section above
Function	Function of Client Map Descriptor	RDBC, WRBC, WRBX

4.4.2 Driver Related Map Descriptor Parameters

Column Title	Function	Legal Values
Node_Name	Name of Node to fetch data from	One of the node names specified in "Client Node Descriptor" above
Address*	This field is only required if the address/length method of module position specification is used.	1..16 Indicating 1 st to 16 th module position.
Length	Length of Map Descriptor Only some commands / queries use the value of this map descriptor parameter. This is indicated in a table provide in chapter 6. For those commands and queries that do use the Length parameter the driver never uses more than 16 elements of data even if the length is set to a larger number. Although this driver does not use the length parameter for some commands the FieldServer kernel does use this parameter to ensure that no more than one client map descriptor has <i>control</i> of a range of array data elements. For this reason it is best to always specify the length – in these cases set it to 1.	1 - 1000

<p>Opto22_trigger*</p>	<p>An optional parameter. If used then set the value of this parameter to <i>yes</i> or <i>no</i> and the <i>da_byte_name</i> parameter must be specified too.</p> <p>When this parameter is set to <i>yes</i> then the Optomux driver processes this map descriptor differently from a normal wrbc or rdbc function.</p> <p>The driver processes the map descriptor at the scan interval specified. Each time that it is processed the driver checks the element of the <i>da_byte_name</i> data array specified. If the value of the 1st element of array located at <i>data_array_offset</i> is 1 then the driver executes the command. If the value is not equal to one then the driver ignores the map descriptor.</p> <p>If the map descriptor is triggered then the driver will write a response status to the same data element on completion of the poll. Thus the value of 1 will be set to zero for success or some other value indicating an error.</p> <p>More information is provided in chapter 6.</p>	<p>No, Yes</p>
<p>Opto22_format*</p>	<p>This parameter only has meaning when the function is a read of digital data.</p> <p>By default the OPTO22 devices returns 16 position states when digital data is read (eg. READ STATUS). The Optomux driver writes the data as one 16 bit unsigned integer to one data element of the data array specified. (That is, the data is written to the data array in packed bit format.)</p> <p>For example, if the 1st and 5th inputs were on and all others were off the driver would write the value 17 to the first element of the data array.</p> <p>The driver can be instructed to unpack this data into separate bit states, writing each module position's state to a consecutive data array element.</p> <p>When the <i>Bit</i> keyword is used the driver sets the states of consecutive data array elements starting at <i>Data_Array_Offset</i>. The number of elements that are written is determined by <i>length</i> and a maximum of 16 elements will be written.</p>	<p>Bit, Packed</p>
<p>Opto22_function</p>	<p>This parameter is specified by using one of</p>	<p>See Table 6.1</p>

	<p>the functions provided in table 6.1.</p> <p>The parameter must be spelled and spaced exactly as provided in the table. Leading and trailing spaces are not important but inter-word spaces are very important. Take care not to use tabs.</p>	
Opto22_modifier1*	<p>A few Opto22_Functions require one ore more additional arguments.</p> <p>SET TIME DELAY GENERATE N PULSES READ AND AVERAGE INPUTS</p> <p>Additional information in chapter 6 will indicate the types of values that may be assigned to this parameter.</p>	See Chapter 6.
Opto22_modifier2*	See Opto_modifier1	
Opto22_mask*	<p>The mask specifies the positions (1-16) of a module that will be affected by a command.</p> <p>The positions can be specified dynamically using a data array or statically by using this parameter.</p> <p>When this parameter is used and its value is non zero then the driver does not consider the data contained in the position defining array even if it is also defined.</p> <p>The value of the mask may be specified in hexadecimal or in decimal.</p> <p>To specify a number in hexadecimal the number must be prefixed with 0x and have a maximum of 4 digits.</p> <p>Examples.</p> <p>Decimal: 257 -> Indicates the 1st and 9th positions.</p> <p>Hexadecimal: 0x0101 -> indicates the 1st and 9th positions.</p>	<p>0-65535</p> <p>or</p> <p>0x0000 – 0xffff</p>

4.4.3 Timing Parameters

Column Title	Function	Legal Values
Scan_Interval	Rate at which data is polled	>0.1s

4.4.4 Map Descriptor Example 1 – Read on/off Status

In this example the on/off status of all module positions of the Optomux device are read and stored. They are read continuously (rdbc) every 5 seconds (Scan_Interval). The Read Status command returns one packed 16 bit value. There is one bit per module position, thus, if the returned value was 2 then this would indicate that the 2nd position is on and all other positions are off.

```
Map_Descriptor_Name, Data_Array_Name, Data_Array_Offset, Function, node_name, Length, Scan_Interval, opto22_function ,  
DEVICE77_STAT , DISC_INPUTS , 0 , rdbc , DEV77 , 1 , 5.0s , READ STATUS ,
```

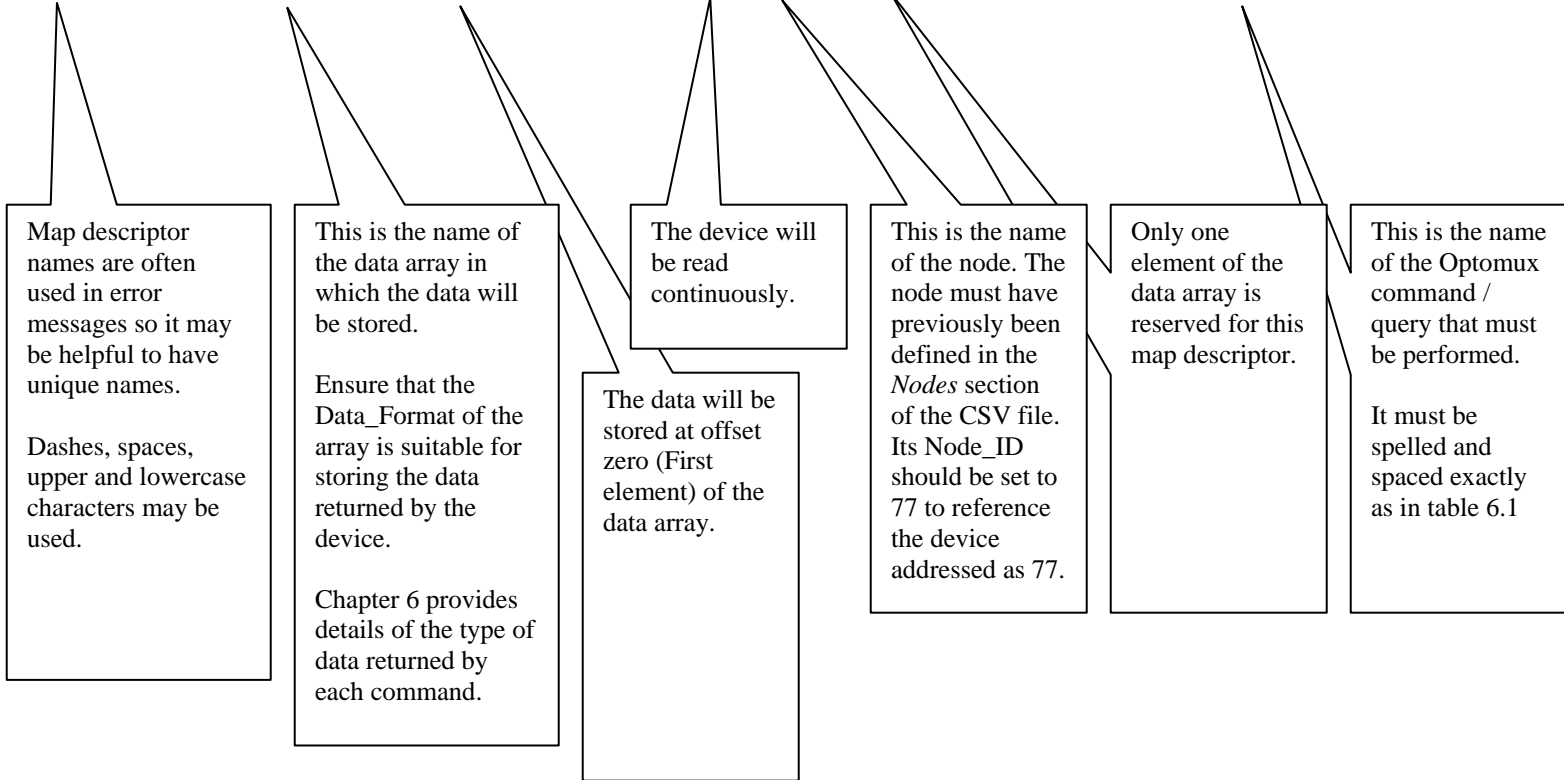

4.4.5 Map Descriptor Example 2 – Read On/Off Status (Data stored differently)

This example reads the same data as the previous example. The difference is that the data is stored differently. In this example the data is unpacked and stored in 16 consecutive data array elements – one element per module position.

Map_Descriptor_Name, Data_Array_Name, Data_Array_Offset, Function, node_name, Length, Scan_Interval, opto22_function , opto22_format
DEVICE77_STAT , DISC_INPUTS , 0 , rdbc , DEV77 , 16 , 5.0s , READ STATUS , Bit

The length has changed to 16 to reserve 16 data array elements for this map descriptor.

This is how the driver is instructed to unpack the digital data.

4.4.6 Map Descriptor Example 3 – Command Response/Completion Status

We use example 1 to show how it can be modified to get the driver to expose the response / status generated when the command was executed. The response / status values indicate the success / failure of the command based either on the driver's ability to complete the command OR on the ack/nack returned by the device.

Map_Descriptor_Name, Data_Array_Name, Data_Array_Offset, Function, node_name, Length, Scan_Interval, opto22_function , DA_Byte_Name
DEVICE77_STAT , DISC_INPUTS , 0 , rdbc , DEV77 , 1 , 5.0s , READ STATUS, RESPONSE_ARR

By virtue of defining the DA_Byte_Name parameter the driver will now store a response status each time the poll is executed.

The response / status code will be stored in the data array called REPONSE_ARR. One element of the array located at Data_Array_Offset will be used. The data array's data format should at least be able to store a byte of data as response/status codes range from 0-255.

4.4.7 Map Descriptor Example 4 – Triggered Action

This example shows the elements necessary to generate a triggered poll. Even though this map descriptor appears to write to the device continuously the driver recognizes the opto22_trigger parameter and based on its value will only send the poll when the trigger value is set.

Map_Descriptor_Name, Data_Array_Name, Data_Array_Offset, Function, Node_Name, Length, Scan_Interval, opto22_function , opto22_trigger, DA_Byte_Name
DEVICE77_STAT , CNTR_POSNS , 0 , wrbc , DEV77 , 16 , 0.2s , CLEAR COUNTERS , Yes , COMMAND_ARRAY

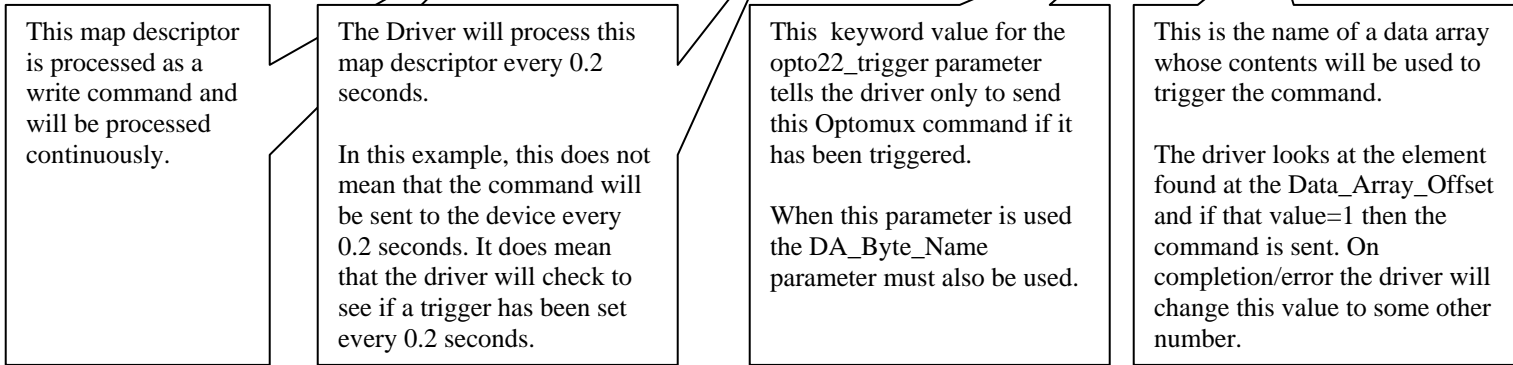

4.4.8 Map Descriptor Example 5 – Using Address and Length to tell the FieldServer which module positions to access.

This example shows a map descriptor which reads analog inputs from an Optomux Device. The address and length tell the driver which inputs to read. Take care to ensure that the data array used for storage has a data format suitable for storing the data type returned by the command. In this case an unsigned integer at least 16 bits long (eg UINT16 or FLOAT). Also take care to ensure that you understand the scaling of the data returned by the Optomux device. There are parameters that you can add to a map descriptor to have the driver scale the value. This is discussed in the FieldServer Configuration Manual.

```
Map_Descriptor_Name, Data_Array_Name, Data_Array_Offset, Function, Node_Name, Address, Length, Scan_Interval, opto22_function  
DEVICE77_STAT , ANA_DATA , 0 , rdbc , DEV77 , 2 , 15 , 1.0s , READ ANALOG INPUTS
```

Data read from the Optomux Device is placed in this array.

Starting at this array position.

The first module position that is read is position 2.
Module positions are numbered 1 to 16.

Data from 15 module positions must be read. Thus starting at 2, the last module position read is 16.

This is the Optomux Driver function that must be performed.

4.4.9 Map Descriptor Example 6 – Using a Mask to Address specific module positions

There may be occasions when it is not suitable to use address and length. For example if you are attempting to address non-consecutive Optomux module positions OR when you wish to use a command that affects all module positions. The driver provides an alternate method for module position specification by allowing you to specify a mask as a parameter in the CSV file. The mask may be specified in decimal or hexadecimal format.

In this example, module positions 1 and 5 are pulsed.

```
Map_Descriptor_Name, Data_Array_Name, Data_Array_Offset, Function, Node_Name, Length, Scan_Interval, opto22_mask, opto22_function
PULSE77, TIME_DATA, 0, wrbc, DEV77, 1, 10.0s, 0x0011, START ON PULSE
```

Module positions are specified in hexadecimal in this example.

0x0001 = Module Position 1
0x0002 = Module Position 2
0x0003 = Module Positions 1 & 2
.....

This function turned on the specified module positions for a specified period. Un specified positions (mask bit positions equal zero) are non affected by the command.

4.4.10 Map Descriptor Example 7 – Specifying Module Positions Dynamically

Previous examples addressed module positions statically. This example illustrates how you can use a data array's value to specify the module position's to be affected by a command. As data arrays can have their values changed by remote devices, the module position specification may be changed dynamically. The CSV file does not require editing. This method can be used all the time or only if you wish to use one of those commands which would typically require dynamic addressing.

In this example, module positions 1 and 5 are pulsed.

```
Map_Descriptor_Name, Data_Array_Name, Data_Array_Offset, Function, Node_Name, Length, Scan_Interval, DA_Bit_Name , opto22_function
CLRLOW77 , LOW_ARRAY , 0 , wrbc , DEV77 , 16 , 10.0s , POS_ARR , READ AND CLEAR LOWEST VALUES
```

In this example, the driver will store 16 lowest values in an array called LOW_ARR starting at position Data_Array_Offset.

Any number 1 to 16.
The driver stops at 16, ignoring larger values.

This data array will be used by the driver to determine the module positions to be affected by the command.
The driver uses the length (max=16) and the Data_Array_Offset. The first specified element corresponds to module position 1. If its value is non-zero then the position is specified by the driver.

5 Configuring the FieldServer as a Optomux Server

The FieldServer does not support the emulation of an Optomux server at present.

6 Driver Notes

6.1 Data Array Name, DA Bit Name, DA Byte Name

These parameters are used to specify data array names. Despite their names a data array of any Data_Format can be used for any of these parameters.

This driver uses DA_Byte_Name exclusively as a location for the commands to trigger map descriptors and in which to store poll response status.

The use of DA_Bit_Name is command sensitive and is used to allow the values in a data array to determine the module positions to be affected by a command.

The use of the Data_Array_Name Parameter is typical i.e. Used to store data that is read or used as a source for data that is written.

6.2 Module Positions

Specify module positions Statically by

- Using Address and Length or
- Using the opto22_mask parameter or

Specify module positions dynamically by

- Using the values of a data array (da_bit_array)

What happens if more than one method is used for module position specification ? The driver evaluates the specification in the order listed above. Thus if address & length are specified as well as the opto22_mask, the driver will use the address and length.

6.3 Command Response Status

If a data array is specified using the DA_Byte_Array parameter then the driver will store a response status code in the array, updating the value each time a command is executed.

Value	Description
0	Command completed successfully.
1	Used to trigger a command.
	All other values indicate error conditions. For Responses 128 to

	255 the Optomux literature should be read for additional information as these are codes returned by the Optomux device.
128	Nak from Optomux Device. Power Up Clear Expected. Command Ignored.
129	Nak from Optomux Device. Undefined Command
130	Nak from Optomux Device. Checksum Error
131	Nak from Optomux Device. Input Buffer Overrun
132	Nak from Optomux Device. Non Printable Ascii character received
133	Nak from Optomux Device. Data Field Error
134	Nak from Optomux Device. Communication watchdog timeout
135	Nak from Optomux Device. Specified limits invalid.
	The following codes are generated by the driver. They all indicate errors.
250	An ack with no data was expected. Ack with Data was received.
251	The driver Complete function returned an error, could be checksum, bad 1st char ... ie. The message was badly formatted.
252	Driver Timeout
253	An ack was received but it was badly formatted
254	A nak was received but was badly formatted
255	Message was not acknowledged correctly.

6.4 Optomux Commands

The following provides a list of commands supported by the driver. The Command Name's provided in the table must be used in providing values for the opto22_function parameter. The notes provided only apply when module positions are specified dynamically.

Read/ Write/ Both	COMMAND NAME	OPTO22_FORMAT OPTION	MASTER LENGTH CONSIDERED (See Notes)	NOTES
w	POWER UP CLEAR		4	
w	RESET		4	
w	SET TURN-AROUND DELAY		4	Uses 1 element of data array. Legal values are 0,1,2,3
w	SET WATCHDOG DELAY		4	Uses 1 element of data array. Legal values are 0 to 7
w	SET WATCHDOG DELAY (Analog)		3	Uses the 1st element of data array for the timer value.
w	SET PROTOCOL		4	Uses 1 element of data array. Legal values are 0,1
r	IDENTIFY Optomux TYPE		4	Polled data is stored in the 1st element of the data array.
w	SET ENHANCED DIGITAL WATCHDOG		3	Delay is found in data array.
w	SET ENHANCED ANALOG WATCHDOG		1	Uses up to Length (max=16) array elements. Module positions specified get setup for fail values by using the corresponding positions in data array.
w	SET TIMER RESOLUTION			Uses 1 element of data array.
w	SET TEMPERATURE PROBE TYPE		3	Temp probe type is found in first element of data array
w	CONFIGURE POSITIONS		3	Non-zero module positions get set to outputs. Zero module positions get set to inputs
w	CONFIGURE AS INPUTS		3	Only module positions specified get affected by command.
w	CONFIGURE AS OUTPUTS		3	Only module positions specified get affected by command.
r	READ MODULE CONFIGURATION		4	
w	WRITE OUTPUTS		1	Uses up to Length (max=16) array elements. Non-zero elements get turned on, zero value elements get turned off.
w	ACTIVATE OUTPUTS		3	Only module positions specified get affected by command.
w	DEACTIVATE OUTPUTS		3	Only module positions specified get affected by command.
r	READ STATUS	1	2	If format=Bit then length is considered during storage as bits are unpacked into data array. If format is non equal to bit then result is written as a single value into one array element. Retrieved data is stored in data array.
w	SET LATCH EDGES		3	Always affects all module positions. Cannot be limited by length. Length is only used when determining which module positions are specified as non-zero. Non-zero (Specified) elements get set on->off, Zero (Non-

Read/ Write/ Both	COMMAND NAME	OPTO22_FORMAT OPTION	MASTER LENGTH CONSIDERED (See Notes)	NOTES
				Specified) module positions get set off->on
w	SET LATCH OFF TO ON		3	Only module positions specified get affected by command.
w	SET LATCH ON TO OFF		3	Only module positions specified get affected by command.
r	READ LATCHES	1	2	If format=Bit then length is considered during storage as bits are unpacked into data array. If format is non equal to bit then result is written as a single value into one array element.
b	READ AND CLEAR LATCHES	1	3,2	Non-zero (Specified) module positions get affected (cleared) by command. But all positions get read. Read data get stored in data array. During storage opto22_format is considered. If format=bit then data is unpacked and stored otherwise the result for all 16 positions is stored as one data element.
w	CLEAR LATCHES		3	Only module positions specified get affected by command.
w	START/STOP COUNTERS		3	All positions are affected by command. Non-zero (specified) module positions start counting, zero (unspecified) module positions stop counting
w	START COUNTERS		3	Only module positions specified get affected by command.
w	STOP COUNTERS		3	Only module positions specified get affected by command.
r	READ COUNTERS		1	Data that is read is put into the corresponding array elements of the data array based on which module positions are read.
b	READ AND CLEAR COUNTERS		1	Data that is read is put into the corresponding array elements of the data array based on which module positions are read.
w	CLEAR COUNTERS		3	Only module positions specified get affected by command.
w	SET TIME DELAY		3	The Modifier is specified in the CSV file with the opto22_modifier1 parameter. The data (timeout) is retrieved from the first element of the data array.
w	INITIATE SQUARE WAVE		3	
w	HIGH RESOLUTION SQUARE WAVE		3	
w	RETRIGGER TIME DELAY		3	Only module positions specified get affected by command.
w	GENERATE N PULSES		3	Only specified module positions get

Read/ Write/ Both	COMMAND NAME	OPTO22_FORMAT OPTION	MASTER LENGTH CONSIDERED (See Notes)	NOTES
				affected. The Modifier (byte 1&2) are specified in the CSV file with the opto22_modifier1/2 parameters. The data (number of pulses) is retrieved from the 1st element of the data array.
w	START ON PULSE		3	Only specified module positions get affected. The data (period of pulses) is retrieved from the 1st element of the data array.
w	START OFF PULSE		3	Only specified module positions get affected. The data (period of pulses) is retrieved from the first element of the data array.
w	SET TRIGGER POLARITY		3	All Module positions are affected by this command. Non-zero (Specified) module positions triggered by on, zero module positions (un-specified) elements get triggered by off.
w	TRIGGER ON POSITIVE		3	Only module positions specified get affected by command.
w	TRIGGER ON NEGATIVE		3	Only module positions specified get affected by command.
r	READ PULSE COMPLETE BITS	1	2	If format=Bit then length is considered during storage as bits are unpacked into data array. If format is non equal to bit then result is written as a single value into one array element. Retrieved data is stored in standard data array.
r	READ DURATION COUNTERS		3	Only specified module positions get read. Data read gets put in corresponding positions of data array.
b	READ AND CLEAR DURATION COUNTERS		3	Only specified module positions get read. Data read gets put in corresponding positions of data array.
w	CLEAR DURATION COUNTERS		3	Only module positions specified get affected by command.
w	WRITE ANALOG OUTPUTS		3	Only specified module positions get written. Data written gets extracted from corresponding positions of data array.
r	READ ANALOG OUTPUTS		3	Only specified module positions get read. Data read gets put in corresponding positions of data array.
w	UPDATE ANALOG OUTPUTS		3	Only specified module positions get written. Data written gets extracted from corresponding positions of data array.
r	READ ANALOG INPUTS		3	Only specified module positions get read. Data read gets put in corresponding positions of data array.

Read/ Write/ Both	COMMAND NAME	OPTO22_FORMAT OPTION	MASTER LENGTH CONSIDERED (See Notes)	NOTES
r	READ AND AVERAGE INPUT		4	Only one module position may be specified. This position is averaged and the result is put in the first element of the data array The number of samples is specified in modifier1 in the csv file.
w	START INPUT AVERAGING		3	Only specified module positions get affected by command. First element in data array is sent as the number of sample to average over.
r	READ AVERAGE COMPLETE BITS	1	2	If format=Bit then length is considered during storage as bits are unpacked into data array. If format is non equal to bit then result is written as a single value into one array element. Retrieved data is stored in standard data array.
r	READ INPUT AVERAGE DATA		3	Only specified module positions get read. Data read gets put in corresponding positions of data array.
r	READ TEMPERATURE INPUTS		3	Only specified module positions get read. Data read gets put in corresponding positions of data array.
r	READ AVERAGE TEMPERATURE INPUTS		3	Only specified module positions get read. Data read gets put in corresponding positions of data array.
w	SET INPUT RANGE		3	Only specified module positions have their range set to the 2 values found in the data array. 1st is high limit, second is lo limit.
r	READ OUT-OF-RANGE LATCHES		4	High limit latches are placed in first element of data array. Low limit latches are placed in 2nd element of data array.
b	READ AND CLEAR RANGE LATCHES		3	Only specified module positions get read and cleared. Data read gets put in corresponding positions of data array.
w	CLEAR OUT-OF-RANGE LATCHES		4	
r	READ LOWEST VALUES		3	Only specified module positions get read. Data read gets put in corresponding positions of data array.
w	CLEAR LOWEST VALUES		3	Only module positions specified get affected by command.
b	READ AND CLEAR LOWEST VALUES		3	Only specified module positions get read and cleared. Data read gets put in corresponding positions of data array.
r	READ PEAK VALUES		3	Only specified module positions get read. Data read gets put in corresponding positions of data array.
w	CLEAR PEAK VALUES		3	Only module positions specified get

Read/ Write/ Both	COMMAND NAME	OPTO22_FORMAT OPTION	MASTER LENGTH CONSIDERED (See Notes)	NOTES
				affected by command.
b	READ AND CLEAR PEAK		3	Only specified module positions get read and cleared. Data read gets put in corresponding positions of data array.
r	CALCULATE OFFSETS		1	Only specified module positions get calculated and read. Data read gets put in corresponding positions of data array.
w	SET OFFSETS		1	Only specified module positions get written. Data written gets extracted from corresponding positions of data array.
r	CALCULATE AND SET OFFSETS		1	Only specified module positions get calculated and read. Data read gets put in corresponding positions of data array.
r	CALCULATE GAIN COEFFICIENTS		1	Only specified module positions get calculated and read. Data read gets put in corresponding positions of data array.
w	SET GAIN COEFFICIENTS		1	Only specified module positions get written. Data written gets extracted from corresponding positions of data array.
r	CALCULATE AND SET GAIN		1	Only specified module positions get calculated and read. Data read gets put in corresponding positions of data array.
w	SET OUTPUT WAVEFORM R		4	Uses opto22_modifier1/2 from the CSV file set waveform rates and types. Only specified positions get affected. 2 elements of data array are used.
w	IMPROVED OUTPUT WAVEFORMS		4	Uses opto22_modifier1/2 from the CSV file set waveform rates and types. Only specified positions get affected. 3 elements of data array are used.

Notes on how the Length parameter is used in the CSV file.

1. The *length* parameter is always considered.
2. The *length* parameter is only considered when the keyword *Bit* is used in the *opto22_format* parameter.
3. The *length* is only used using the address/length method to specify module positions or when the dynamic method is used to specify module positions.
4. The *length* is never considered.

6.5 Driver Stats

In addition to the standard FieldServer communication statistics described in the FieldServer User's Manual the Optomux Driver can also expose some driver statistics by writing data to a data array. A special map descriptor is required. The driver recognizes the map descriptor by its name which must be "opto22-**stats**".

The following example shows how this special map descriptor can be configured.

```

Nodes
Node_name, Node_ID, Protocol
null_node, 0, Optomux

Data_Arrays
Data_Array_Name, Data_Format, Data_Array_Length
OPTO22_STATS, UINT32, 300

Map_Descriptors
Map_descriptor_Name, Data_Array_Name, Node_name, length
Opto22-stats, OPTO22_STATS, null_node, 300
    
```

When the driver sees this map descriptor it uses the data array SK_STATS (in this example) to store driver specific statistics. Only one of these map descriptors may be specified per FieldServer.

The driver stores the following data.

Array Element	Contents	
0	OPTO_STAT_BAD_FUNCTION	The Opto22_Function has a bad value.
1	OPTO_STAT_DYNAMIC_MASK	Mask cannot be specified in a CSV file with a zero value.
2	OPTO_STAT_TIMEOUT	
3	OPTO_STAT_STREAMING	
4	OPTO_STAT_NAK	
5	OPTO_STAT_PROTOCOL	
6	OPTO_STAT_IC_TIMEOUT	
7	OPTO_STAT_DEVICE_MSG_REC'D	
8	OPTO_STAT_DEVICE_BYTES_REC'D	
9	OPTO_STAT_DEVICE_FUNCTION	
10	OPTO_STAT_NO_START	
11	OPTO_STAT_MSG_IGNORED	
12	OPTO_STAT_POLL_MSG_SENT	
12	OPTO_STAT_POLL_BYTES_SENT	

7 Revision History

Date	Resp	Format	Driver Ver.	Doc. Rev.	Comment
2/18/04	JD	MF	0	1	Releasing

Free Manuals Download Website

<http://myh66.com>

<http://usermanuals.us>

<http://www.somanuals.com>

<http://www.4manuals.cc>

<http://www.manual-lib.com>

<http://www.404manual.com>

<http://www.luxmanual.com>

<http://aubethermostatmanual.com>

Golf course search by state

<http://golfingnear.com>

Email search by domain

<http://emailbydomain.com>

Auto manuals search

<http://auto.somanuals.com>

TV manuals search

<http://tv.somanuals.com>