

Type 655 and 655R Actuators for Self-Operated Control

Contents

Introduction	1
Scope of Manual	1
Description	1
Specifications	2
Installation	2
Actuator Mounting	3
Loading Connections	6
Startup	6
Startup for Pressure-Reducing Service	6
Startup for Pressure-Relief Service	7
Adjustment for Pressure-Reducing or Pressure-Relief Service	7
Shutdown	7
Maintenance	7
Actuator	8
Top-Mounted Handwheel	10
Parts Ordering	12
Parts List	12



W0466-1 / IL

Figure 1. Type 655-ED Pressure-Reducing Valve

Introduction

Scope of Manual

This instruction manual provides installation, adjustment, maintenance, and parts ordering for the Type 655 and 655R actuators and the top-mounted handwheel. Refer to separate instruction manuals for information about valves and accessories used with these actuators.

Do not install, operate, or maintain 655 and 655R actuators without first • being fully trained and qualified in valve, actuator, and accessory installation, operation, and maintenance, and • carefully reading and understanding the contents of this manual. If you have any questions about these instructions, contact your Emerson Process Management™ sales office before proceeding.

Description

Type 655 and 655R actuators (figure 1) are pressure-actuated, spring-and-diaphragm actuators used in conjunction with various valves to provide

control for a wide variety of pressure regulation applications. Type 655 actuators are used for pressure-reducing service when mounted on push-down-to-close valves such as the Design ED and ET valves. Type 655R actuators are used for pressure-relief service when mounted on push-down-to-open valves such as the Design EDR and ETR valves. Both types are self-operated and direct-acting; that is, increasing pressure in the diaphragm casing forces the actuator stem downward, and decreasing the pressure allows the actuator spring to lift the actuator stem upward.

Note

Neither Emerson, Emerson Process Management, nor any of their affiliated entities assumes responsibility for the selection, use and maintenance of any product. Responsibility for the selection, use, and maintenance of any product remains with the purchaser and end-user.



655 and 655R Actuators

Table 1. Specifications

Actuator Sizes and Maximum Casing Pressures

ACTUATOR SIZE	MAXIMUM CASING PRESSURE	
	Bar	Psig
3A, 4A	17.2	250
3B, 4B	12.1	175
32, 42	6.9	100
33, 43	4.5	65
34, 44	3.1	45
35, 45	2.1	30
36, 46	1.0	15

Actuator Pressure Setting Ranges

See table 2

Actuator Yoke Boss and Valve Stem Connection Diameters

Sizes 3A through 36: 54 mm (2-1/8 inch) yoke boss with 9.5 mm (3/8 inch) stem connection
Sizes 4A through 46: 71 mm (2-13/16 inch) yoke boss with 12.7 mm (1/2 inch) stem connection

Maximum Travel

Sizes 3A and 4A: 11 mm (0.4375 inch) plus 3 mm (0.125 inch) for seating

All Other Sizes: 19 mm (0.75 inch) plus 3 mm (0.125 inch) for seating

Effective Diaphragm Area

See table 3

Spring Rate

See key 6 in the parts list section

Temperature Capabilities

-29 to 82°C (-20 to 180°F) with standard diaphragm material. For the fluid and temperature capabilities of nonstandard diaphragm materials, consult your Emerson Process Management sales office

Casing Pressure Connections

1/2 NPT internal

Approximate Weights

ACTUATOR SIZE	APPROXIMATE WEIGHT	
	Kg	Lb
3A, 3B, 32, 33	20	45
34, 35, 36	23	50
4A, 4B, 42, 43	29	65
44, 45, 46	34	75

Specifications

Specifications for the Type 655 and 655R actuators are shown in table 1. Information for a specific actuator is also found on the nameplate of that actuator.

Installation



WARNING

To avoid personal injury or property damage caused by bursting of pressure-retaining parts, be certain the service conditions do not exceed the casing pressure limits listed in table 1. Use pressure-limiting or pressure-relieving devices to prevent service conditions from exceeding these limits.

Always wear protective gloves, clothing, and eyewear when performing any installation operations to avoid personal injury.

Check with your process or safety engineer for any additional measures that must be taken to protect against process media.

If installing into an existing application, also refer to the WARNING at the beginning of the Maintenance section in this instruction manual.

Type 655 and 655R actuators are normally shipped mounted on a valve. Refer to the appropriate valve instruction manual when installing the valve in the pipeline. If the actuator is shipped separately or if it is necessary to mount the actuator on the valve, perform the procedures described in the Actuator Mounting portion of this section.

CAUTION

To avoid premature wear of the diaphragm due to debris in the pressure line to the diaphragm, install a strainer in the pipeline ahead of the regulator or relief valve.

Before installing the actuator, inspect it for any damage. Also, keep any adjacent piping clean and free of pipe scale or other debris that could possibly disrupt service. It is recommended that a strainer be installed in the pipeline ahead of the regulator or relief valve to protect it while in service. And a conventional three-valve bypass (see figure 2) should be placed around the regulator or relief valve to permit continuous operation when it is being installed or repaired.

Actuator Mounting

The actuator may be installed either above or below the pipeline.

CAUTION

In steam service applications, avoid premature wear of the diaphragm, due to high temperature steam, by installing the valve with the actuator positioned below the pipeline.

If the regulator or relief valve is to be used for steam service, the valve should be installed with the actuator positioned below the pipeline, and the control line should be sloped down toward the diaphragm casing. This is to ensure that any forming condensate will maintain a water seal to protect the diaphragm.

The following procedure describes how to mount the actuator on either a push-down-to-close or a push-down-to-open valve so that the actuator stem and valve stem thread engagement will allow full travel and proper shutoff. Refer to figure 3 for actuator mounting components. Key numbers refer to figure 4 unless otherwise stated.

1. Turn the adjusting screw (key 10) into the yoke (key 7) to force the diaphragm (key 2) and diaphragm

plate (key 4) against the upper diaphragm casing (key 1).

2. Perform the following steps as appropriate for either push-down-to-close or push-down-to-open valve action.

CAUTION

In the following procedures, do not rotate the valve plug while it is seated since this may cause damage to the seating surfaces and thereby allow excessive leakage. Also, during travel adjustment, use tools carefully to avoid damaging the valve plug stem. A damaged stem could cut the packing and allow leakage.

For Push-Down-To-Close Valves:

- a. Place the actuator part way over the valve stem. Then, place the yoke locknut over the valve stem, and slide the travel indicator disk (key 11, if used) on top of the hex nuts (key 12).
- b. Set the actuator onto the valve body. The length of the valve stem will prevent the actuator yoke (key 7) from sitting on the bonnet properly. Measure the distance from the bottom of the actuator yoke to the mating shoulder on the bonnet, and then add the valve plug travel to this measurement.
- c. Raise the actuator so the valve plug can be lifted off the seat ring.

Note

Either turn the actuator, or tighten the hex nuts together, and use a wrench on the hex nuts to turn the valve plug and stem assembly.

Thread the valve stem into the actuator stem the distance measured in the previous step.

- d. Lower the actuator onto the valve body bonnet, and tighten the yoke locknut.
- e. Connect the pressure control lines as described in the Loading Connection portion of this section.

Table 2. Actuator Pressure-Setting Ranges⁽¹⁾

ACTUA-TOR SIZE	SPRING PART NUMBER	PRESSURE REDUCTION				PRESSURE RELIEF				ACTUA-TOR SIZE	SPRING PART NUMBER	PRESSURE REDUCTION				PRESSURE RELIEF				
		Minimum		Maximum		Minimum		Maximum				Minimum		Maximum		Minimum		Maximum		
		Bar	Psig	Bar	Psig	Bar	Psig	Bar	Psig			Bar	Psig	Bar	Psig	Bar	Psig	Bar	Psig	
3A, 4A	1E792427082	5.4	78	12.0	174	4.5	65	10.1	146	44	1E793327082	0.9	13	1.9	28	0.8	11	1.6	23	
	1F714327092	3.0	44	9.3	135	3.0	43	8.2	119		1E795427082	0.8	11	1.6	23	0.6	9.0	1.3	19	
	1F176927092	2.2	32	6.6	96	2.6	37	5.9	85		34, 44	1E792427082	0.6	9.0	1.4	20	0.5	7.0	1.1	16
	1F176827092	1.8	26	5.4	78	2.3	34	5.2	75			1F714327092	0.3	5.0	1.1	16	0.3	5.0	0.9	13
	1F176727032	1.3	19	4.1	59	1.4	20	3.9	57			1F176927092	0.3	3.8	0.8	11	0.3	4.0	0.7	10
3B	1E793327082	3.4	50	7.4	107	3.0	43	4.4	64	35	1F176827092	0.2	2.8	0.6	8.5	0.1	2.0	0.6	8.5	
	1E795427082	2.9	42	6.3	92	2.4	35	4.4	64		1E793327082	0.6	8.3	1.2	18	0.5	7.0	0.8	11	
4B	1E793327082	3.4	50	7.4	107	3.0	43	6.1	89	45	1E795427082	0.5	7.0	1.0	15	0.4	5.5	0.8	11	
	1E795427082	2.9	42	6.3	92	2.4	35	5.3	77		1E793327082	0.6	8.3	1.2	18	0.5	7.0	1.0	15	
3B, 4B	1E792427082	2.4	35	5.4	78	2.0	29	4.4	64	35, 45	1E795427082	0.5	7.0	1.0	15	0.4	5.5	0.9	13	
	1F714327092	1.4	20	4.1	60	1.3	19	3.7	53		1E792427082	0.4	5.8	0.9	13	0.3	5.0	0.8	11	
	1F176927092	1.0	14	3.0	43	1.2	17	2.6	38		1F714327092	0.2	3.3	0.7	10	0.2	3.2	0.6	9.0	
32	1E793327082	2.2	32	4.5	65	1.8	26	2.6	38	36	1F176927092	0.2	2.4	0.5	7.2	0.2	2.8	0.4	6.3	
	1E795427082	1.8	26	3.8	55	1.5	22	2.6	38		1F176827092	0.1	2.0	0.4	5.9	0.2	2.5	0.4	5.5	
42	1E793327082	2.2	32	4.5	65	1.8	26	3.7	53	46	1F176727032	0.1	1.5	0.3	4.4	0.1	1.5	0.3	4.2	
	1E795427082	1.8	26	3.8	55	1.5	22	3.1	45		1F714427112	0.07	1.0	0.2	2.9	0.09	1.3	0.2	2.8	
32, 42	1E792427082	1.5	22	3.2	47	1.2	18	2.6	38	36	1E793327082	0.4	5.8	0.9	13	0.3	5.0	0.5	7.7	
	1F714327092	0.8	12	2.5	36	0.8	12	2.1	31		1E795427082	0.3	4.9	0.8	11	0.3	4.2	0.5	7.7	
33	1E793327082	1.3	19	2.8	40	1.1	16	1.7	24	46	1E793327082	0.4	5.8	0.9	13	0.3	5.0	0.8	11	
	1E795427082	1.1	16	2.3	34	0.9	13	1.7	24		1E795427082	0.3	4.9	0.8	11	0.3	4.2	0.6	9.0	
43	1E793327082	1.3	19	2.8	40	1.1	16	2.3	33	36, 46	1E792427082	0.3	4.1	0.6	9.2	0.2	3.5	0.5	7.7	
	1E795427082	1.1	16	2.3	34	0.9	13	1.9	28		1F714327092	0.2	2.3	0.5	7.1	0.2	2.3	0.4	6.3	
33, 43	1E792427082	1.0	14	2.0	29	0.8	11	1.7	24	36, 46	1F176927092	0.1	1.7	0.4	5.1	0.1	2.0	0.3	4.5	
	1F714327092	0.5	7.0	1.5	22	0.5	7.0	1.4	20		1F176827092	0.09	1.3	0.3	4.2	0.1	1.8	0.3	4.0	
	1F176927092	0.4	5.2	1.1	16	0.3	5.0	1.1	16		1F176727032	0.07	1.0	0.2	3.1	0.08	1.1	0.2	3.0	
34	1E793327082	0.9	13	1.9	28	0.8	11	1.1	16	36, 46	1F714427112	0.05	0.7	0.1	2.1	0.06	0.9	0.1	2.0	
	1E795427082	0.8	11	1.6	23	0.6	9.0	1.1	16		1F713027112	0.02	0.34	0.08	1.1	0.05	0.7	0.07	1.0	

1. Effects of packing box friction, unbalance, and weight of valve plug not considered in calculations.

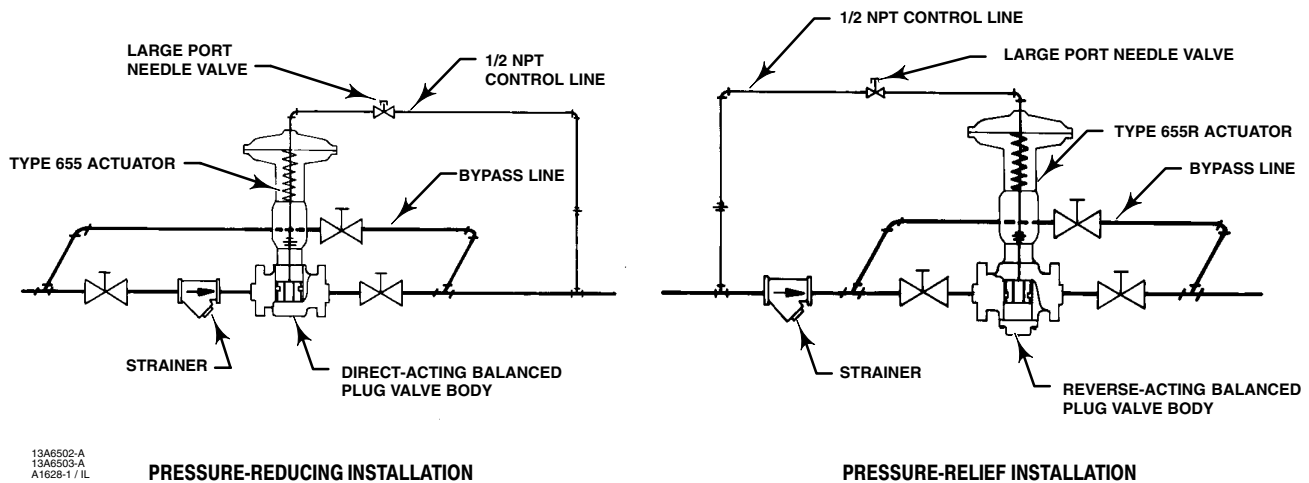
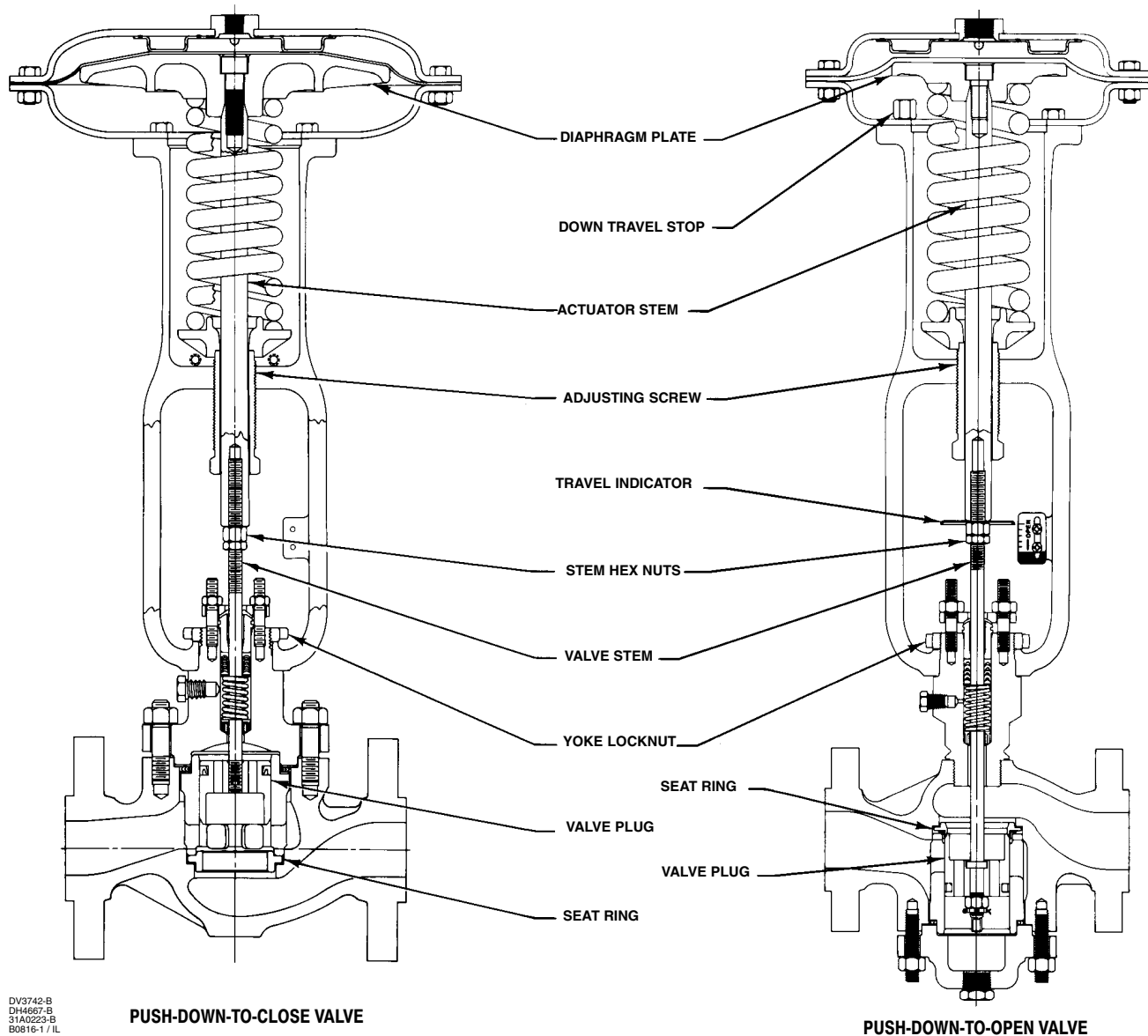

Figure 2. Typical Installation Schematics

Table 3. Effective Diaphragm Area⁽¹⁾

ACTUA- TOR SIZE	TRAVEL DOWN FROM UPPER CASING STOP, mm (IN.)																			
	0		3 (0.125)		5 (0.1875)		6 (0.25)		10 (0.375)		11 (0.4375)		13 (0.5)		14 (0.5625)		19 (0.75)		22 (0.875)	
	Cm ²	In. ²	Cm ²	In. ²	Cm ²	In. ²	Cm ²	In. ²	Cm ²	In. ²	Cm ²	In. ²	Cm ²	In. ²	Cm ²	In. ²	Cm ²	In. ²	Cm ²	In. ²
3A, 4A	66	10.2	62	9.6	61	9.5	61	9.4	59	9.2	59	9.1	57	8.9	56	8.7	---	---	---	---
3B, 4B	152	23.5	139	21.6	136	21.1	134	20.8	132	20.5	131	20.3	130	20.1	128	19.8	117	18.1	103	16.0
32, 42	258	40.0	235	36.4	227	35.2	221	34.2	210	32.6	205	31.8	200	31.0	195	30.3	182	28.2	170	26.4
33, 43	406	63.0	374	58.0	366	56.8	358	55.5	345	53.5	340	52.7	335	52.0	330	51.2	318	49.3	307	47.6
34, 44	600	93.0	547	84.8	534	82.8	523	81.0	508	78.8	502	77.8	497	77.0	490	76.0	474	73.5	465	72.0
35, 45	865	134.0	834	129.2	821	127.2	809	125.4	788	122.2	777	120.5	768	119.0	759	117.6	736	114.1	723	112.0
36, 46	1230	190.0	1170	181.5	1150	179.0	1140	177.0	1120	173.5	1110	172.3	1100	171.0	1100	169.8	1070	166.5	1050	163.5

1. For the spring rates of a particular spring, see key 6 in the Parts List section.



DV3742-B
DH4667-B
31A0223-B
B0816-1/L

Figure 3. Actuator/Valve Components

655 and 655R Actuators

f. Stroke the actuator, and measure the stem movement to check travel. If the movement is more than full travel, turn the valve stem out of the actuator stem the amount of over-travel. If movement is less than full travel, turn the valve stem into the actuator stem the amount of under-travel.

For Push-Down-To-Open Valves:

a. Place the actuator, yoke locknut, and travel indicator disk (key 11, if used) over the valve stem. Support the actuator above the valve body so the actuator stem and valve stem do not contact when the valve plug is seated.

b. Connect the pressure control lines as described in the Loading Connection portion of this section.

c. Move the valve plug, by hand, from the seated to the open position, and make sure that valve stem movement corresponds to the desired travel.

d. Stroke the actuator until the diaphragm plate (key 4) contacts the down travel stop (see figure 3).

e. With the valve plug positioned as described in step c above, lower the actuator until the actuator stem contacts the valve stem, and measure the distance from the bottom of the actuator yoke to the mating shoulder on the bonnet.

f. Thread the valve stem into the actuator stem until the thread engagement is equal to the distance measured in the previous step. Tighten the hex nuts (key 12) together, and use a wrench to turn the valve plug and stem assembly.

g. Lower the actuator onto the valve body bonnet, and tighten the yoke locknut.

h. Stroke the actuator, and measure the stem movement to check travel. If the movement is more than full travel, turn the valve stem into the actuator stem the amount of over-travel. If the movement is less than full travel, turn the valve stem out of the actuator stem the amount of under-travel.

3. After correct travel has been obtained, tighten the hex nuts (key 12) against the actuator stem (key 8), and tighten the yoke locknut with a hammer and punch.

Note

Changing the spring adjustment will not change the actuator pressure range for that particular spring (see table 2). Changing the spring adjustment merely shifts the position of the spring either up or down so that valve travel can coincide with the actuator pressure setting range.

4. While monitoring loading pressure with a pressure gauge, stroke the actuator, and then turn the adjusting screw until the valve begins to travel at the desired pressure. Turn the adjusting screw out of the yoke to decrease spring compression and thus allow the valve to begin travel at a lower loading pressure. Turn the adjusting screw into the yoke to increase spring compression and thus allow the valve to begin travel at a higher loading pressure.

Loading Connections

Install the control line following the steps listed below. Typical installations are shown in figure 2.

1. Connect the control line into either the upstream pipeline for pressure-relief service or into the downstream pipeline for pressure-reducing service as shown in figure 2. Make the pipeline tap at least four to eight pipe diameters away from the regulator or relief valve, or any elbow, swage, or nipple, to avoid abnormal velocities or turbulence.

2. Connect the other end of the control line to the 1/2 NPT connection in the center of the upper diaphragm casing (key 1) or to the connection in the handwheel body (key 28, figures 5 and 6; key 142, figure 7).

3. Fit the control line with a large-port needle valve. Partially closing or throttling this valve will tend to dampen any cycling or pulsating action of the regulator. Never completely close the needle valve while the regulator is in operation.

Startup

The procedures for placing into operation and adjusting the equipment for both pressure-reducing and pressure-relief applications are described below. Typical installation schematics are shown in figure 2.

Startup For Pressure-Reducing Service

1. Open the needle valve in the control line.
2. Open the downstream shutoff valve.
3. Close the valve in the bypass line.

4. Slowly open the upstream shutoff valve.

Startup For Pressure-Relief Service

1. Open the needle valve in the control line.
2. Open the downstream shutoff valve.
3. Slowly open the upstream shutoff valve.
4. Close the valve in the bypass line.

Adjustment For Pressure-Reducing or Pressure-Relief Service

The actuator is factory-set as specified on the order, and the pressure range is stamped on the nameplate. If a pressure setting other than the one specified is desired, change the pressure setting by following the procedures listed below. Be sure to change the nameplate to indicate the new pressure setting. The new pressure setting must not exceed the limits given in tables 1 and 2 or in any applicable codes.

CAUTION

To protect equipment in the process system from a sudden release of pressure, always use a pressure gauge to monitor pressure when making adjustments.

To adjust the downstream pressure setting for pressure-reducing service, or the upstream pressure setting for pressure-relief service, proceed as follows. To decrease the pressure setting, turn the adjusting screw (key 10, figure 4) counterclockwise; to increase the pressure setting, turn the adjusting screw clockwise. If the spring does not provide the required pressure setting, replace it through the following steps:

1. Disassemble the actuator by following steps 1, 3 and 4 of the Disassembly portion of the Maintenance section.
2. Remove the diaphragm (key 2). Then, unscrew the cap screw (key 3), and lift the diaphragm plate (key 4) out of the actuator body.
3. Replace the spring and reassemble the actuator by following steps 5 and 6 of the Assembly portion of the Maintenance section.

Shutdown

For both pressure-reducing and pressure-relief applications, refer to figure 2, and follow the procedures described below.

1. Close the upstream shutoff valve slightly.
2. Slowly open the bypass valve while monitoring downstream pressure.
3. Slowly close the downstream shutoff valve.
4. Close the upstream shutoff valve.
5. Close the needle valve in the control line.

Maintenance

Actuator parts are subject to normal wear and must be inspected and replaced when necessary. The frequency of inspection and replacement depends on the severity of service conditions.

WARNING

Avoid personal injury or property damage from sudden release of process pressure or bursting of parts. Before performing any maintenance operations:

- Always wear protective gloves, clothing, and eyewear when performing any maintenance operations to avoid personal injury.
- Disconnect any operating lines providing air pressure, electric power, or a control signal to the actuator. Be sure the actuator cannot suddenly open or close the valve.
- Use bypass valves or completely shut off the process to isolate the valve from process pressure. Relieve process pressure from both sides of the valve. Drain the process media from both sides of the valve.
- Vent the power actuator loading pressure and relieve any actuator spring precompression.
- Use lock-out procedures to be sure that the above measures stay in effect while you work on the equipment.
- The valve packing box may contain process fluids that are

655 and 655R Actuators

pressurized, *even when the valve has been removed from the pipeline.*

Process fluids may spray out under pressure when removing the packing hardware or packing rings, or when loosening the packing box pipe plug.

- **Check with your process or safety engineer for any additional measures that must be taken to protect against process media.**

The maintenance instructions are divided into two sections: Actuator and Top-Mounted Handwheel.

Actuator

This procedure describes how the actuator can be completely disassembled and assembled. When inspection or repairs are required, disassemble only those parts necessary to accomplish the job; then, start the assembly at the appropriate step.

Key numbers refer to figure 4.

Disassembly

CAUTION

In the following procedure, do not rotate the valve plug while it is seated since this may cause damage to the seating surfaces and thereby allow excessive leakage. Also, during travel adjustment, use tools carefully to avoid damaging the valve plug stem. A damaged stem could cut the packing and allow leakage.

1. Rotate the handwheel (if one is used) counterclockwise to be sure the handwheel is not compressing the spring (key 6).
2. For complete disassembly, the actuator must be removed from the valve, and the actuator stem (key 8) must be completely disengaged from the valve plug stem by rotating the actuator. Perform the appropriate procedure according to the respective valve action.

For Push-Down-To-Close Valves:

Note

To prevent the actuator stem (key 8) from rotating while performing the

following procedure, make sure the adjusting screw (key 10) remains screwed into the yoke (key 7).

- a. Loosen the two hex nuts (key 12).
- b. Loosen the yoke locknut (figure 3) with a hammer and punch, and unscrew it from the valve bonnet.
- c. While lifting the actuator so that the valve plug is not forced against the seat, rotate the entire actuator until the actuator stem disengages completely from the valve plug stem.

For Push-Down-To-Open Valves:

- a. Turn the adjusting screw (key 10) counterclockwise to relieve all spring compression. Then, move the valve plug, by hand, off the seat.
 - b. Loosen the hex nuts (key 12), and unscrew the valve plug stem out of the actuator stem as far as it will go.
 - c. Turn the adjusting screw into the yoke (key 7) to force the diaphragm (key 2) and diaphragm plate (key 4) against the upper diaphragm casing (key 1).
 - d. Loosen the yoke locknut (figure 3) with a hammer and punch, and unscrew it from the valve bonnet.
 - e. Rotate the entire actuator until the actuator stem disengages from the valve plug stem.
3. Turn the adjusting screw (key 10) counterclockwise out of the yoke (key 7) to relieve all spring compression.
 4. To remove the upper diaphragm casing (key 1), unscrew the cap screws (key 19) for size 3A and 4A actuators or the cap screws and hex nuts (keys 19 and 20) for all other sizes.
 5. Remove the diaphragm (key 2); then, lift the diaphragm plate (key 4) and actuator stem assembly out of the actuator body. Also, remove the spring and the lower spring seat (key 9).
 6. For size 3A and 4A actuators, remove the lower diaphragm casing (key 5).
 7. Remove the cap screw (key 3), and separate the diaphragm plate from the actuator stem.
 8. For size 3B through 46 actuators, unscrew the cap screws (key 21), and remove the lower

diaphragm casing (key 5). Some Type 655R actuators will have travel stops (key 13, not shown) in place of three of these six cap screws.

9. If a top-mounted handwheel assembly is used, refer to steps 4 through 8 of the Disassembly portion of the Top-Mounted Handwheel section.

Assembly

This procedure assumes that the actuator is completely disassembled. If it is not, start the instructions at the appropriate step.

1. Before starting assembly, apply moly-grease lubricant to the threads and the bearing end of the adjusting screw (key 10) as indicated in figure 4 by the letter A.
2. For size 3A and 4A actuators, set the lower diaphragm casing (key 5) onto the yoke (key 7).
3. For size 3B through 46 actuators, install the lower diaphragm casing (key 5), and secure it with the cap screws (key 21). Some Type 655R actuators will have travel stops (key 13, not shown) in place of three of these six cap screws.
4. Install the lower spring seat (key 9) and the actuator spring (key 6).

Note

To take some of the slack out of the diaphragm (key 2) at the bolt circle, turn the adjusting screw into the yoke (key 7) to raise the diaphragm plate (key 4). This will also ensure that the diaphragm will have enough slack inside the casings for efficient travel.

5. Secure the diaphragm plate (key 4) to the actuator stem (key 8) with the cap screw (key 3), and install this assembly into the actuator. Install the diaphragm, making sure that the patterned side of the diaphragm is next to the diaphragm plate.

Note

When replacing the upper diaphragm casing (key 1), be sure there are no wrinkles in the diaphragm that might cause the diaphragm to tear or allow leakage.

6. Place the upper diaphragm casing onto the lower diaphragm casing. For size 3A and 4A actuators, secure the casings with the cap screws (key 19). For all other actuator sizes, secure the casing with the cap screws and hex nuts (keys 19 and 20).

Note

When you replace actuator diaphragms in the field, take care to ensure the diaphragm casing bolts are tightened to the proper load to prevent leakage, but not crush the material. Perform the following tightening sequence with a manual torque wrench.

CAUTION

Over-tightening the diaphragm cap screws (key 19) or cap screws and nuts (keys 19 and 20) can damage the diaphragm. Do not exceed 27 N•m (20 lbf•ft) torque.

Note

Do not use lubricant on these bolts and nuts. Fasteners must be clean and dry.

7. Install the upper diaphragm casing (key 1), and install the cap screws (key 19) or cap screws and nuts (keys 19 and 20). Tighten in the following manner.
8. The first four bolts tightened should be diametrically opposed and 90 degrees apart. Tighten these four bolts to 13 N•m (10 lbf•ft).
9. Tighten the remaining bolts in a clockwise, criss-cross pattern to 13 N•m (10 lbf•ft).
10. Repeat this procedure by tightening four bolts, diametrically opposed and 90 degrees apart, to a torque of 27 N•m (20 lbf•ft).
11. Tighten the remaining bolts in a clockwise, criss-cross pattern to 27 N•m (20 lbf•ft).
12. After the last bolt is tightened to 27 N•m (20 lbf•ft), all of the bolts should be tightened again to 27 N•m (20 lbf•ft) in a circular pattern around the bolt circle.
13. Once completed, no more tightening is recommended.
14. Mount the actuator onto the valve by following the procedures outlined in the Actuator Mounting portion of the installation section.
15. Connect the pressure control line by following the procedures outlined in the Loading Connections portion of the Installation section.

655 and 655R Actuators

16. To start up and adjust the actuator, follow the procedures outlined in the Startup section of this instruction manual.

Top-Mounted Handwheel

Top-mounted handwheel assemblies (figures 5, 6 and 7) are normally used as adjustable travel stops to limit full upward travel of the actuator stem. Turning the handwheel clockwise forces the actuator stem downward, while turning the handwheel counterclockwise allows the spring to force the actuator stem upward. If the actuator is used with a push-down-to-close valve, full opening of the valve plug can be restricted through the appropriate positioning of the top-mounted handwheel. If the actuator is used with a push-down-to-open valve, closing of the valve plug can be restricted by using the handwheel. A locknut (key 27, figures 5 and 6; key 137, figure 7) is used to hold the handwheel in position.

Instructions are given below for complete disassembly and assembly. Perform the disassembly only as necessary to accomplish the required maintenance; then, begin the assembly at the appropriate step.

Key numbers refer to figure 5 for size 3A and 4A, figure 6 for size 3B and 4B, and figure 7 for size 32 through 46 top-mounted handwheel assemblies.

Disassembly

1. Bypass the control valve. Relieve all loading pressure, and remove the tubing or pipe from the handwheel body.
2. Loosen the hex nut (key 27, figures 5 and 6; key 137, figure 7). Turn the adjusting screw (key 10, figure 4) and the handwheel (key 25, figures 5 and 6; key 51, figure 7) counterclockwise to relieve all compression.
3. For size 3A and 4A actuators, remove the cap screws (key 19, figure 4), and lift the handwheel body (key 28, figure 5) off the actuator.
4. For size 3B through 46 actuators, remove the cap screws and hex nuts (keys 19 and 20, figure 4), and then lift off the upper diaphragm casing (key 1, figure 4) and handwheel assembly. To replace the O-ring (key 139, figure 7) or for ease of handling, separate the handwheel assembly from the upper diaphragm casing. This can be accomplished by removing the cap screws that secure the handwheel assembly to the upper diaphragm casing (key 33, figure 6; key 141, figure 7).

5. Turn the handwheel clockwise two or three turns. Remove the hex nut (key 22, figures 5 and 6; key 54, figure 7) and washer (key 24, figures 5 and 6; key 134, figure 7), and lift off the handwheel.

6. Unscrew the locknut (key 27, figures 5 and 6; key 137, figure 7) from the handwheel stem (key 26, figures 5 and 6; key 133, figure 7), and then remove the handwheel stem through the bottom of the handwheel body (key 28, figures 5 and 6; key 142, figure 7). A screwdriver slot in the top of the handwheel stem is provided for this purpose.

7. Check the O-ring (key 29, figures 5 and 6; key 138, figure 7), and replace it if necessary.

8. To complete disassembly, drive out the groove pin (key 31, not shown; key 140, figure 7), and slide the pusher plate (key 32, figures 5 and 6; key 135, figure 7) off the handwheel stem. For Type 655, size 3B and 4B actuators, a travel stop (key 34, figure 6) should also be removed with these parts.

Assembly

This procedure assumes that the handwheel assembly is completely disassembled. If it is not, start the instructions at the appropriate step.

1. During assembly, apply lithium grease lubricant (key 241) to the handwheel stem and threads, the pusher, and to the O-rings as shown in figures 5, 6 and 7.
2. Slide the pusher plate (key 32, figures 5 and 6; key 135, figure 7) onto the handwheel stem, and, if necessary, insert the groove pin (key 31, not shown; key 140, figure 7). For Type 655, size 3B and 4B actuators, a travel stop (key 34, figure 6) should also be inserted on the handwheel stem with these parts.
3. Insert the handwheel stem into the handwheel body (key 28, figures 5 and 6; key 142, figure 7); then, screw the hex nut (key 27, figures 5 and 6; key 137, figure 7) onto the handwheel stem.
4. Install the handwheel (key 25, figures 5 and 6; key 51, figure 7) and washer (key 24, figures 5 and 6; key 134, figure 7) onto the handwheel stem, and secure it with the hex nut (key 22, figures 5 and 6; key 54, figure 7).
5. **For size 3A and 4A actuators**, set the handwheel body onto the actuator, and secure it with the cap screws (key 19, figure 4).

Note

When you replace actuator diaphragms in the field, take care to ensure the diaphragm casing bolts are

tightened to the proper load to prevent leakage, but not crush the material. Perform the following tightening sequence with a manual torque wrench.

ensure the diaphragm casing bolts are tightened to the proper load to prevent leakage, but not crush the material. Perform the following tightening sequence with a manual torque wrench.

CAUTION

Over-tightening the diaphragm cap screws (key 19) can damage the diaphragm. Do not exceed 27 N•m (20 lbf•ft) torque.

Note

Do not use lubricant on these bolts and nuts. Fasteners must be clean and dry.

6. Install the upper diaphragm casing (key 1), and install the cap screws (key 19). Tighten in the following manner.
7. The first four bolts tightened should be diametrically opposed and 90 degrees apart. Tighten these four bolts to 13 N•m (10 lbf•ft).
8. Tighten the remaining bolts in a clockwise, criss-cross pattern to 13 N•m (10 lbf•ft).
9. Repeat this procedure by tightening four bolts, diametrically opposed and 90 degrees apart, to a torque of 27 N•m (20 lbf•ft).
10. Tighten the remaining bolts in a clockwise, criss-cross pattern to 27 N•m (20 lbf•ft).
11. After the last bolt is tightened to 27 N•m (20 lbf•ft), all of the bolts should be tightened again to 27 N•m (20 lbf•ft) in a circular pattern around the bolt circle.
12. Once completed, no more tightening is recommended. Proceed to step 21.
13. **For size 3B through 46 actuators**, set the upper diaphragm casing (key 1, figure 4) and handwheel assembly onto the actuator body, and secure it with the cap screws and hex nuts (keys 19 and 20, figure 4).

Note

When you replace actuator diaphragms in the field, take care to

CAUTION

Over-tightening the diaphragm cap screws and nuts (keys 19 and 20) can damage the diaphragm. Do not exceed 27 N•m (20 lbf•ft) torque.

Note

Do not use lubricant on these bolts and nuts. Fasteners must be clean and dry.

14. Install the upper diaphragm casing (key 1), and install the cap screws and nuts (keys 19 and 20). Tighten in the following manner.
15. The first four bolts tightened should be diametrically opposed and 90 degrees apart. Tighten these four bolts to 13 N•m (10 lbf•ft).
16. Tighten the remaining bolts in a clockwise, criss-cross pattern to 13 N•m (10 lbf•ft).
17. Repeat this procedure by tightening four bolts, diametrically opposed and 90 degrees apart, to a torque of 27 N•m (20 lbf•ft).
18. Tighten the remaining bolts in a clockwise, criss-cross pattern to 27 N•m (20 lbf•ft).
19. After the last bolt is tightened to 27 N•m (20 lbf•ft), all of the bolts should be tightened again to 27 N•m (20 lbf•ft) in a circular pattern around the bolt circle.
20. Once completed, no more tightening is recommended.
21. Connect the pressure control line to the top-mounted handwheel assembly by following the procedures outlined in the Loading Connections portion of the Installation section.
22. To start up and adjust the actuator, follow the procedures outlined in the Startup section of this instruction manual.

655 and 655R Actuators

Parts Ordering

When corresponding with your Emerson Process Management sales office about this equipment, refer to the serial number found on the actuator nameplate (key 17, figure 4). Also, specify the complete 11-character part number from the following parts list when ordering replacement parts.



WARNING

Use only genuine Fisher replacement parts. Components that are not supplied by Emerson Process Management should not, under any circumstances, be used in any Fisher valve, because they will void your warranty, might adversely affect the performance of the valve, and could give rise to personal injury and property damage.

Note

Neither Emerson, Emerson Process Management, nor any of their affiliated entities assumes responsibility for the selection, use and maintenance of any product. Responsibility for the selection, use, and maintenance of any product remains with the purchaser and end-user.

Parts List

Note

Part numbers are shown for recommended spares only. For part numbers not shown, contact your Emerson Process Management sales office.

Actuator

Key	Description	Part Number
1	Upper Diaphragm Casing	
2*	Diaphragm, chloroprene	
	Sizes 3A & 4A	1F725102192
	Sizes 3B & 4B	1F725902192
	Sizes 32 & 42	
	W/o top-mounted handwheel	1F702202112
	W/ top-mounted handwheel	1F702202192
	Sizes 33 & 43	
	W/o top-mounted handwheel	1F702302112
	W/ top-mounted handwheel	1F7023X0012
	Sizes 34 & 44	
	W/o top-mounted handwheel	1F702402112
	W/ top-mounted handwheel	1F7024X0022
	Sizes 35 & 45	
	W/o top-mounted handwheel	1F702502112
	W/ top-mounted handwheel	1F7025X0022
	Sizes 36 & 46	
	W/top-mounted handwheel	1F7026X0012
3	Cap Screw	
4	Diaphragm Plate	
5	Lower Diaphragm Casing	
6	Spring	See following table
7	Yoke	
8	Actuator Stem	

Instruction Manual

Form 1292
July 2007

655 and 655R Actuators

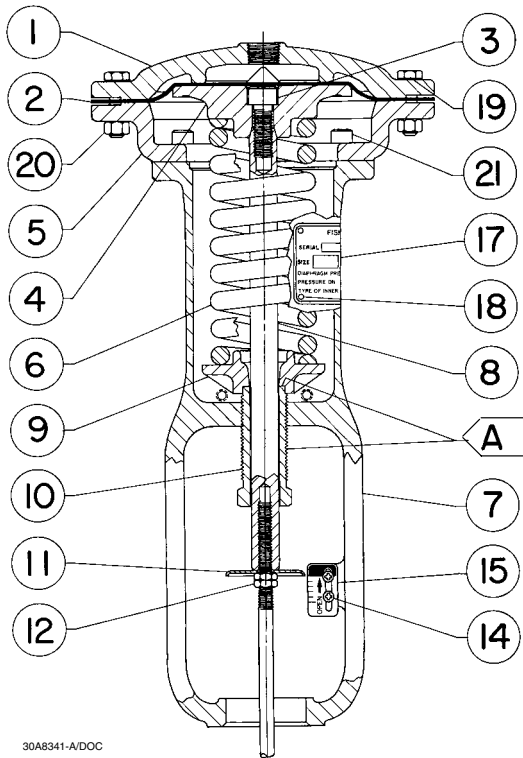

30A8341-A/DOC

A APPLY MOLY-GREASE LUBRICANT TO ADJUSTING SCREW

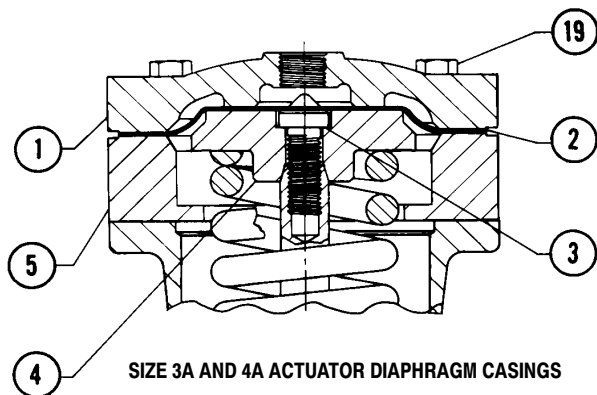

30A8342-A/DOC

Figure 4. Type 655 Actuator

Key	Description	Part Number
9	Lower Spring Seat	
10	Adjusting Screw	
11	Travel Indicator Disk	
12	Hex Nut	
13	Travel Stop	
14	Screw	
15	Travel Indicator Scale	
16	Twin Speed Nut	
17	Nameplate	

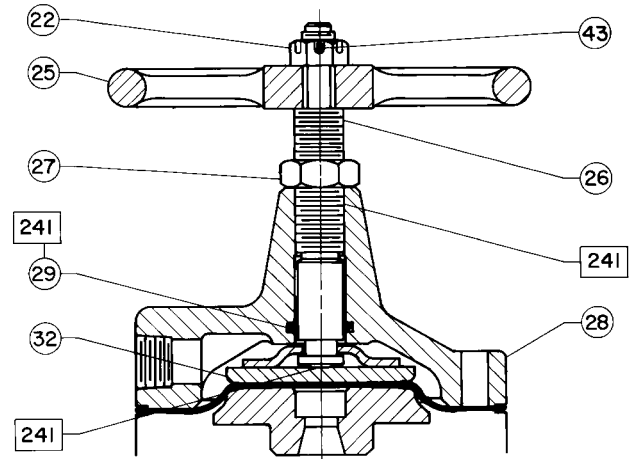

□ APPLY LUB

PART NOT SHOWN : 31

28A1216-C/DOC

Figure 5. Size 3A and 4A Top-Mounted Handwheel Assembly

Key	Description	Part Number
18	Drive Screw	
19	Cap Screw	
20	Hex Nut	
21	Cap Screw	

Top-Mounted Handwheel

Sizes 3A, 4A, 3B & 4B

22	Hex Jam Nut	
24	Washer	
25	Handwheel	
26	Handwheel Stem	
27	Hex Jam Nut	
28	Handwheel Body	
29*	O-Ring, nitrile	1D237506992
30*	O-Ring, nitrile (not shown)	Sizes 3B & 4B only 1D267306992
31	Groove Pin	
32	Pusher Plate	
33	Cap Screw	
34	Travel Stop	

Sizes 32 thru 46

51	Handwheel	
54	Hex Nut	
133	Handwheel Stem	
134	Washer	
135	Pusher	
137	Hex Nut	
138*	O-Ring, nitrile	1D237506992
139*	O-Ring, nitrile	1D267306992
140	Groove Pin	
141	Cap Screw	
142	Handwheel Body	
241	Lithium grease lubricant-1, 0.396 kg (14 oz.) can (not furnished with actuator)	

*Recommended spare parts

655 and 655R Actuators

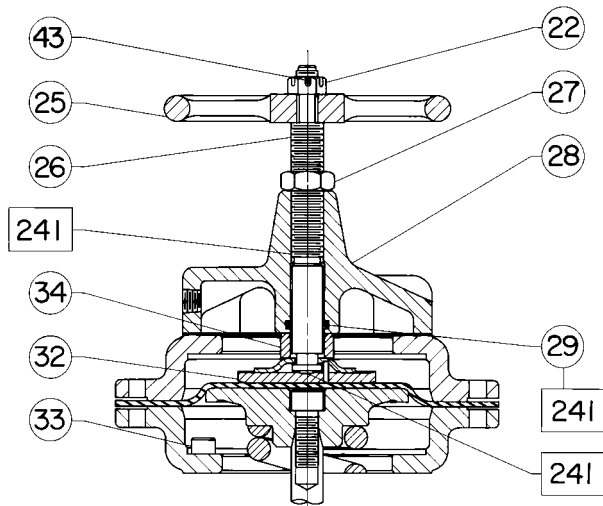

APPLY LUB

PARTS NOT SHOWN : 30 & 31

38A1217-B/DOC

Figure 6. Size 3B and 4B Top-Mounted Handwheel Assembly

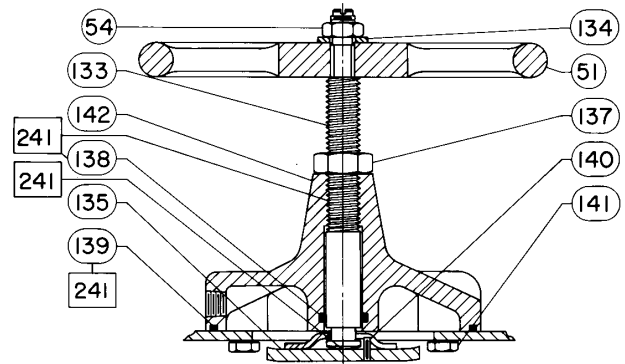

BV8008-E/DOC

Figure 7. Size 32 through 46 Top-Mounted Handwheel Assembly.

Key 6 Spring, steel

COLOR CODE	SPRING RATE		SAFE LOAD	
	N/mm	Lb/in.	N	Lb
Aluminum & red	22	123	1290	290
Aluminum & dark green	43	246	2420	545
Dark green	64	368	3750	843
Aluminum	86	490	4720	1060
Dark blue	107	612	5200	1187
Aluminum & dark blue	145	830	7250	1630
Light blue	220	1260	8184	1840
Light green	257	1470	9790	2200
Light grey	310	1770	11,600	2600
Yellow	368	2100	13,500	3045
Dark grey	129	735	5160	1160
Aluminum & brown	175	1000	7000	1575
White	441	2520	14,010	3150

Fisher is a mark owned by Fisher Controls International LLC, a member of the Emerson Process Management business division of Emerson Electric Co. Emerson Process Management, Emerson, and the Emerson logo are trademarks and service marks of Emerson Electric Co. All other marks are the property of their respective owners.

The contents of this publication are presented for informational purposes only, and while every effort has been made to ensure their accuracy, they are not to be construed as warranties or guarantees, express or implied, regarding the products or services described herein or their use or applicability. We reserve the right to modify or improve the designs or specifications of such products at any time without notice.

Neither Emerson, Emerson Process Management, nor any of their affiliated entities assumes responsibility for the selection, use and maintenance of any product. Responsibility for the selection, use and maintenance of any product remains with the purchaser and end-user.

Emerson Process Management

Marshalltown, Iowa 50158 USA

Cernay 68700 France

Sao Paulo 05424 Brazil

Singapore 128461

www.Fisher.com



Free Manuals Download Website

<http://myh66.com>

<http://usermanuals.us>

<http://www.somanuals.com>

<http://www.4manuals.cc>

<http://www.manual-lib.com>

<http://www.404manual.com>

<http://www.luxmanual.com>

<http://aubethermostatmanual.com>

Golf course search by state

<http://golfingnear.com>

Email search by domain

<http://emailbydomain.com>

Auto manuals search

<http://auto.somanuals.com>

TV manuals search

<http://tv.somanuals.com>