

Fisher & Paykel

Freestanding cooker
OR120 double oven models

**Installation instructions
and User guide**

Safety and warnings	2
Installation instructions	6
Introducing your cooker	20
Using your gas cooktop	21
Cooktop troubleshooting	25
Using your ovens for the first time	26
Oven controls and setting the clock	27
Cooking functions	28
Using the electronic timer	30
Automatic cooking	31
Using your warmer drawer	32
Care and cleaning	33
Warranty and service	47

Important!

SAVE THESE INSTRUCTIONS

The models shown in this document may not be available in all markets and are subject to change at any time. For current details about model and specification availability in your country, please go to our website www.fisherpaykel.com or contact your local Fisher & Paykel dealer.

2 Safety and warnings

Installation

! WARNING!



Electrical Shock Hazard

Always disconnect the cooker from the mains electricity supply before carrying out any maintenance operations or repairs.

Failure to follow this advice may result in death or electrical shock.

! WARNING!



Cut Hazard

Take care - panel edges are sharp.

Failure to use caution could result in injury or cuts.

Important safety precautions

General

- To avoid hazard, follow these instructions carefully before installing or using this product.
- Please make this information available to the person installing the product as it could reduce your installation costs.
- These products are registered:
in New Zealand at www.energysafety.govt.nz
in Australia with AGA at www.gas.asn.au.
- This appliance must be installed in accordance with these installation instructions, local gas fitting regulations, municipal building codes, water supply regulations, electrical wiring regulations, AS5601 / AG 601 and NZS5261 - Gas Installations and any other relevant statutory regulations.
- Failure to install the cooker correctly could invalidate any warranty or liability claims.
- Some appliances have a protective film. Remove this film before using the cooker.
- Do not modify this appliance.
- This appliance is to be installed and serviced only by an authorised person.

Electrical

- This cooker is to be installed and connected to the electricity supply only by an authorised person.
- If the installation requires alterations to the domestic electrical system, call a qualified electrician. The electrician should also check that the electrical system is suitable for the electricity drawn by the cooker.
- The appliance must be connected to the mains electricity supply, checking that the voltage corresponds to the value given in the rating plate and that the electrical cable sections can withstand the load specified on the plate.

- *A suitable disconnection switch must be incorporated in the permanent wiring, mounted and positioned to comply with the local wiring rules and regulations. The switch must be of an approved type installed in the fixed wiring and provide a 3 mm air gap contact separation in all poles in accordance with the local wiring rules.
In Australia and New Zealand, a switch of the approved type with a 3 mm air gap must be installed in the active (phase) conductor of the fixed wiring.*
- *The switch must always be accessible.*
- *The power supply cable must not touch any hot parts and must be positioned so that it does not exceed 75 °C at any point.*
- *To connect the cooker to the mains electricity supply, do not use adapters, reducers or branching devices as they can cause overheating and burning.*
- *This cooker must be connected to a suitable double pole control unit adjacent to the cooker. No diversity can be applied to this control unit.*
- *If the electrical supply cord is damaged, it must only be replaced by an authorised person.*
- *This cooker must be connected to the electrical supply using V105 insulated cable.*
- *The cooker must be earthed.*
- *Do not operate your appliance by means of an external timer or separate remote-control system.*

4 Safety and warnings

Operation

Your freestanding cooker has been carefully designed to operate safely during normal cooking procedures. Please keep the following guidelines in mind when you are using it:

WARNING!



Explosion Hazard

Do not store flammable materials such as gasoline near the cooktop.

Do not store flammable material in the ovens or in the drawers.

Do not spray aerosols near the cooktop during use.

Failure to follow this advice may result in death or serious injury.

WARNING!



Electrical Shock Hazard

Switch the power to the cooker off at the wall before replacing fuses or oven lamps.

Failure to do so may result in death or electrical shock.

WARNING!



Hot Surface Hazard

Accessible parts may become hot when this cooker is in use.

To avoid burns and scalds keep children away.

Do not touch hot surfaces inside the ovens or warmer drawer.

Use oven mitts or other protection when handling hot surfaces such as oven shelves or dishes.

Take care when opening the oven doors.

Let hot air or steam escape before removing or replacing food.

Do not touch the cooktop components, burners, trivets/pan supports or the base when hot.

Before cleaning, turn the cooker off and make sure it is cool.

Failure to follow this advice could result in burns and scalds.

Important safety precautions

- *Isolating switch: make sure this cooker is connected to a circuit which incorporates an isolating switch providing full disconnection from the power supply.*
- *Household appliances are not intended to be played with by children.*
- *Children, or persons with a disability which limits their ability to use the appliance, should have a responsible person to instruct them in its use. The instructor should be satisfied that they can use the appliance without danger to themselves or their surroundings.*
- *Safe food handling: leave food in the oven for as short a time as possible before and after cooking. This is to avoid contamination by organisms which may cause food poisoning. Take particular care during warmer weather.*
- *Do not place aluminium foil, dishes, trays, water or ice on the oven floor during cooking as this will irreversibly damage the enamel.*
- *Do not line the walls with aluminium foil.*
- *Do not stand on the doors, or place heavy objects on it.*
- *Do not use harsh abrasive cleaners or sharp metal scrapers to clean the oven doors' glass since they scratch the surface, which may result in shattering of the glass.*
- *Do not use a steam cleaner to clean any part of the cooker.*
- *Do not use an asbestos mat or decorative covers between the flame and the saucepan as this may cause serious damage to your cooktop.*
- *Do not place aluminium foil or plastic dishes on the cooktop burners.*
- *Do not let large saucepans or frying pans overlap the bench as this can deflect heat onto your benchtop and damage the surface.*
- *Do not let large saucepans, frying pans or woks push any other pans aside. This could make them unstable or deflect heat onto your benchtop and damage the surface.*
- *Saucepan handles may be hot to touch. Ensure saucepan handles do not overhang other gas burners that are on. Keep handles out of reach of children.*
- *If the electrical supply cord is damaged, it must only be replaced by an authorised person.*
- *This cooker is not to be used as a space heater, especially if it is installed in marine craft or in a caravan.*
- *The use of a gas cooking appliance results in the production of heat and moisture in the room in which it is installed. Ensure the kitchen is well ventilated. Keep natural ventilation holes open or install a mechanical ventilation device (mechanical extractor hood). Prolonged intensive use of the appliance may call for additional ventilation, for example opening of a window, or more effective ventilation, for example increasing the level of mechanical ventilation where present.*

6 Installation instructions

Product dimensions

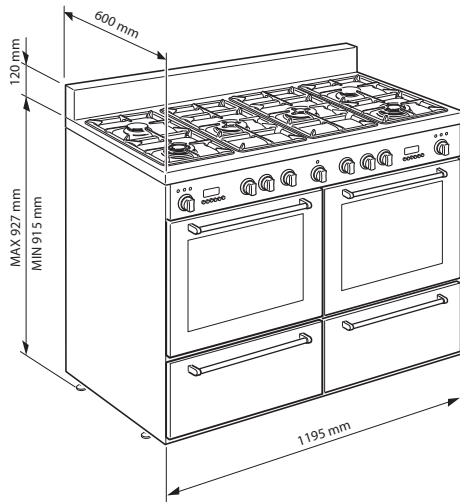

Fig. 1 Product dimensions

Fixing the backguard

- Position the backguard as shown in Fig. 2 and fix it by screwing the five screws "A".

Important!

Installing the backguard is MANDATORY.

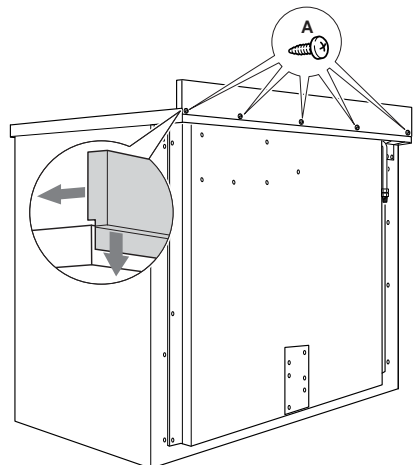

Fig. 2 Fixing the backguard

Clearances

Installation clearances and protection of combustible surfaces shall comply with the current local regulations eg. AG 601 (AS5601/NZS5261) Gas Installations code. Installation shall comply with the dimensions in Fig. 3, bearing in mind the following requirements:

Overhead Clearances

In no case shall the clearance above the highest part of the cooker be less than 650 mm or, for an overhead exhaust fan, 750 mm. All other downward-facing combustible surfaces less than 600 mm above the cooker surface shall be protected for the full width of the cooking surface in accordance with the standards noted above. In no case shall the clearance be less than 450 mm.

Rear and Side Clearances

Where the distance from the periphery of the nearest burner to any vertical combustible surface is less than 200 mm, the surface shall be protected in accordance with the standards to a height of not less than 150 mm above the cooking surface for the full width or depth of the cooking surface.

Where the distance from the periphery of the nearest burner to any horizontal combustible surface is less than 200 mm, the horizontal surface shall be more than 10 mm below the surface of the cooking surface, or the horizontal surface shall be above the trivet (see requirements for vertical combustible surfaces above).

Protection of combustible surfaces

The standards above specify that, where required, protection shall ensure that the surface temperature of combustible surfaces does not exceed 65°C above room temperature.

Do not install the cooker near flammable materials (eg curtains).

If you stand the cooker on a pedestal, make sure you provide safety measures to keep it in place.

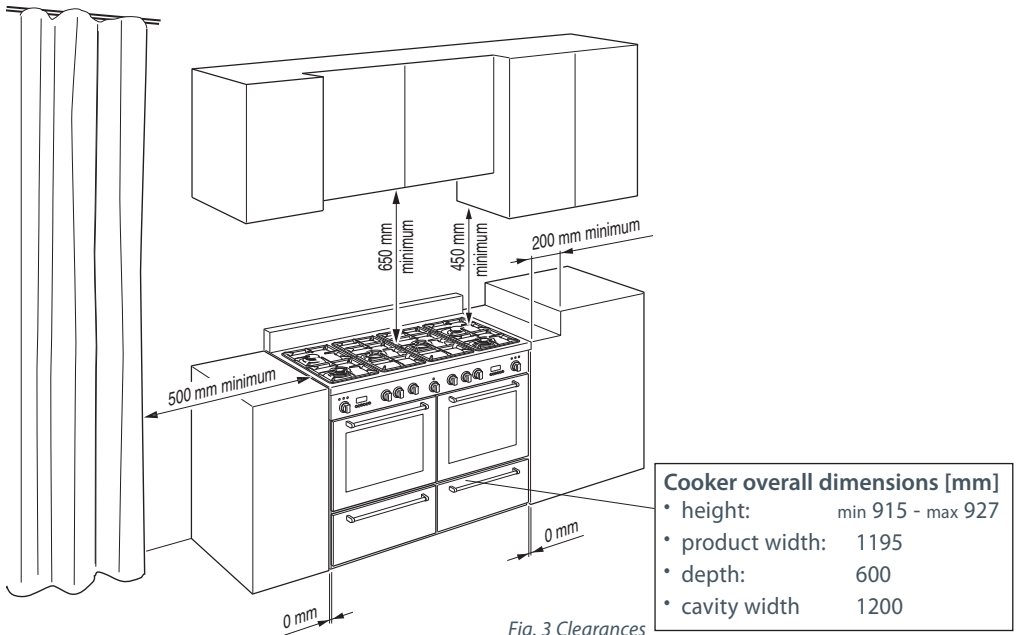

Fig. 3 Clearances

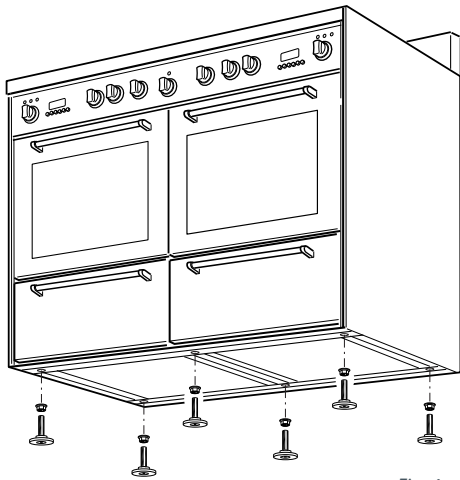

Fig. 4a

Levelling the cooker

Important!

Using the supplied adjustable feet is **MANDATORY**. For safety reasons and to ensure adequate ventilation, the cooker chassis **MUST NOT** sit directly on the floor, a plinth, or other support surface.

- The cooker is already fitted with six levelling feet.
- Level the cooker by screwing or unscrewing the feet (Fig. 4d).
- Make sure you follow the instructions in Figs. 4a, 4b, and 4c.
- Note: nuts are supplied with the cooker in a separate kit.

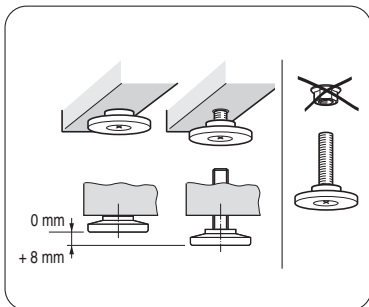

Fig. 4b Do not use the supplied nuts for height adjustments between 0 and 8 mm

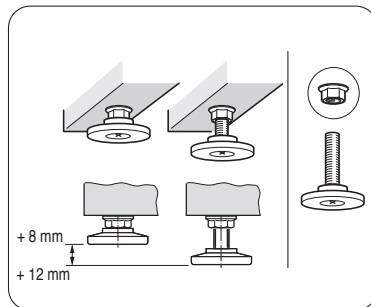

Fig. 4c Use the supplied nuts for height adjustments between 8 and 12 mm

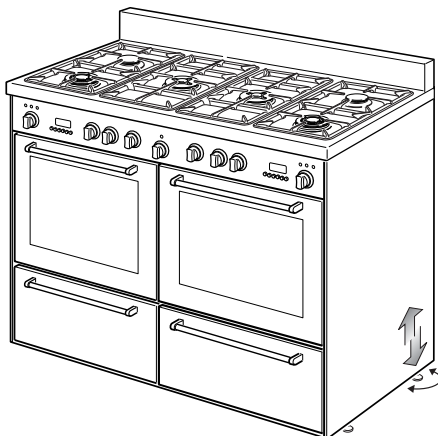

Fig. 4d Screw/unscrew the feet to get the required height

Fitting the anti-tilt bracket

Important!

To restrain the appliance and prevent it tipping accidentally, the anti-tilt bracket and restraining plate supplied must be fitted according to the instructions below.

- 1 Drill four 8mm diameter holes for the fixing screws (two in the wall and two in the floor-see Fig.5) and insert the plastic plugs supplied.

Important!

Before drilling the holes, check that you will not damage any pipes or electrical wires.

- 2 Attach the anti-tilt bracket to the floor and rear wall using the four screws supplied, as shown in Fig. 5.
- 3 After attaching the anti-tilt bracket securely, slide the cooker into place. Ensure that the rear central foot slides under the bracket, as shown in Fig.5.
- 4 Access the bracket by removing the left drawer (Fig. 6):
 - a Slide out the left drawer completely.
 - b Press the lever of the left guide rail down and pull the lever of the right guide rail up.
 - c Holding the levers, disengage and remove the drawer.
- 5 Fix the restraining plate by sliding it into place and securing it with the fixing screw and washer supplied. See Fig. 7.
- 6 Replace the left drawer (Fig. 8):
 - a Insert the drawer rails into the guide rails.
 - b Gently push the drawer in completely; the safety catches will automatically hook.

Important!

Beware of sharp edges when removing or replacing the drawer.

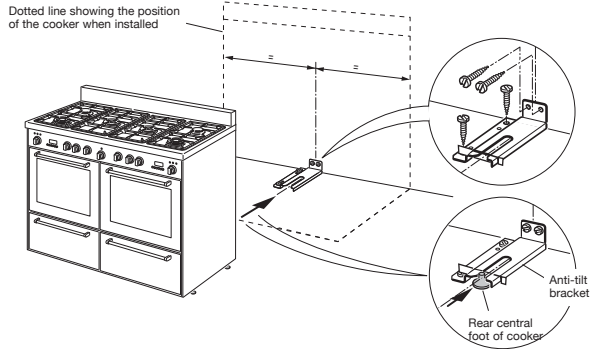

Fig. 5 Attaching the anti-tilt bracket and sliding the cooker into place

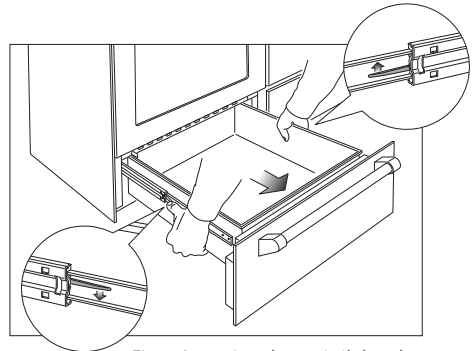

Fig. 6 Accessing the anti-tilt bracket by removing the left drawer

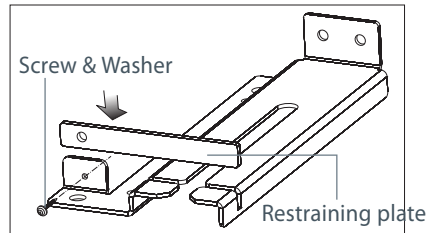

Fig. 7 Fixing the restraining plate

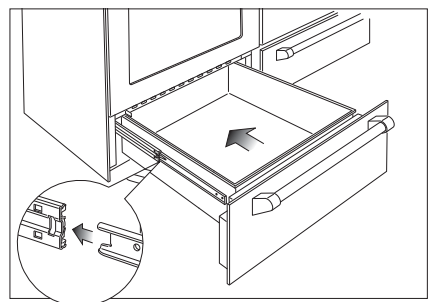

Fig. 8 Replacing the left drawer

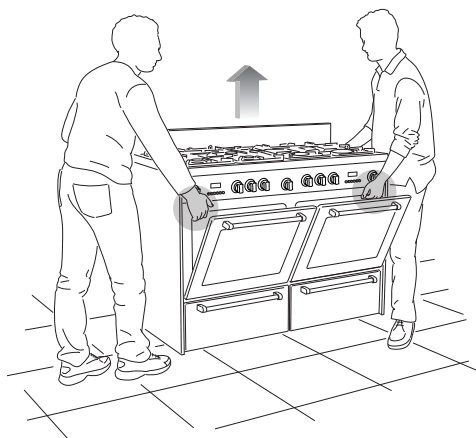

Fig. 9a Correctly lifting the cooker

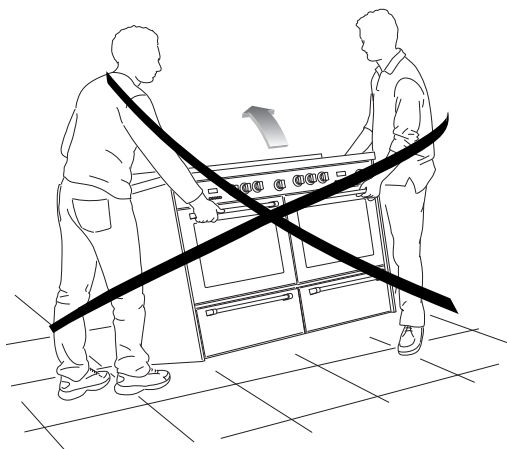

Fig. 9b Incorrectly lifting the cooker

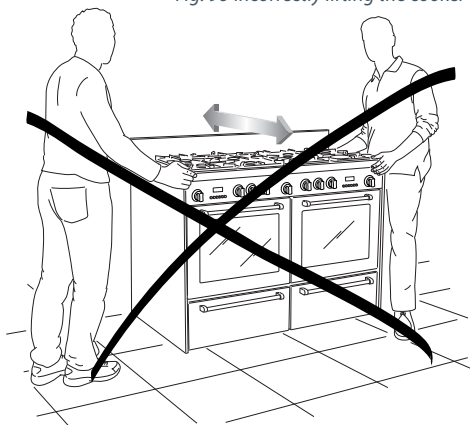

Fig. 9c Incorrectly lifting the cooker

Moving the cooker

Important!

To prevent damaging the adjustable feet, ensure the cooker is always lifted by two people.

Do not lift the cooker by the door handles. **DO NOT DRAG** the cooker. Lift the feet clear of the floor.

Locating the area for gas and electrical connection

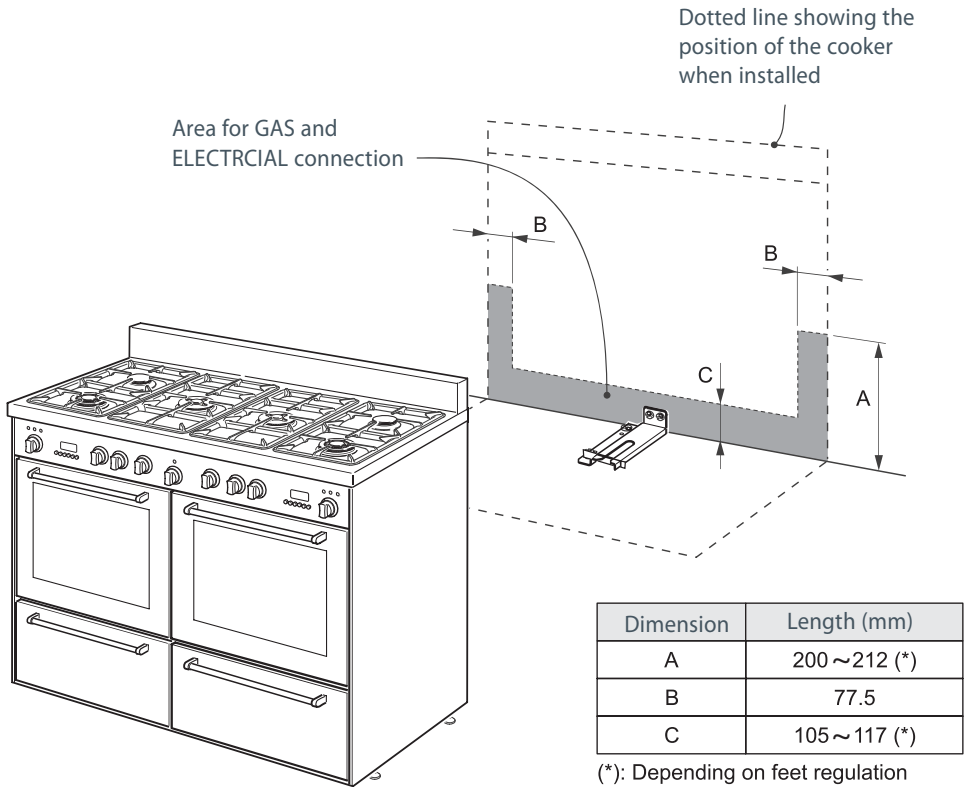

Fig. 10 Locating the area for gas and electrical connection

12 Installation instructions

Connecting the cooker to the gas supply

- The gas connection must be carried out by an authorised person according to the relevant standards.
- Before connecting the appliance to the gas main, mount the brass conical adaptor onto the gas inlet extension pipe, upon which the washer has been placed (see Fig. 12 following).
- Conical adaptor and washer are supplied with the appliance (packed with conversion kit for use with Natural gas or LPG).
- This appliance is suitable for use with Natural gas or LPG gas. (Check the "gas type" sticker attached to the appliance).
- For Natural gas, connect the gas supply to the gas pressure regulator which is supplied with the appliance (Fig.12). Adjust the regulator to obtain a test point pressure of 1 kPa with the two triple-ring wok burners operating at the maximum.
- For LPG, connect the gas supply to the test point adaptor which is supplied with the appliance (Fig.12). Ensure that the supply pressure is regulated to 2.75 kPa.
- The connection must be made at the rear of appliance; the pipe is not to cross the cooker. If the connection pipe does cross the cooker, it must be positioned under the cooker's back panel, as shown (Fig.11).

Important!

Use two spanners to tighten or loosen the connecting pipe and the gas components (Fig.13).

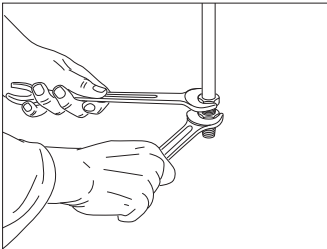

Fig. 13 Adjusting the connecting pipe

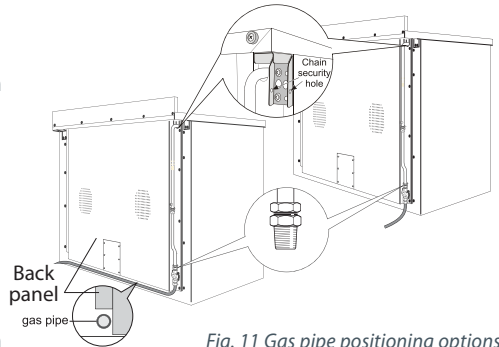

Fig. 11 Gas pipe positioning options

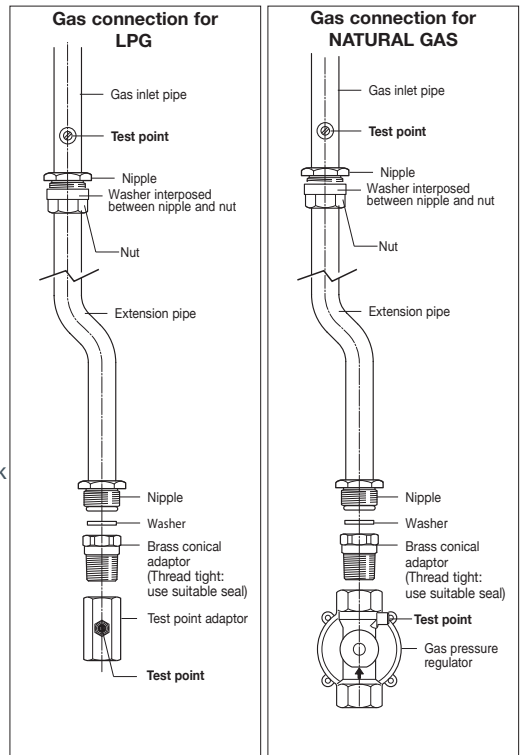

Fig. 12 Gas connection options

Installation with a flexible hose assembly

- If this appliance has to be installed with a hose assembly, the installer shall refer to the network operator or gas supplier for confirmation of the gas type, if in doubt.
- When used with a flexible hose, the connector on the wall should be between 450 mm to 500 mm from the floor and 200 mm to 300 mm from the left-hand side of the appliance as viewed from the front. The hose connection on the appliance shall face downwards.
- It is important that the hose does not come in contact with the metal of the appliance and is secured as per appropriate gas installation codes. A chain 80% of the length of the flexible gas hose must be used to prevent stress being applied to the hose. The chain should be attached securely to the product where shown, and on the wall.
- Flexible hose assemblies should be AS/NZS 1869 Class B or Class D certified. The thread connection shall be Rp 1/2" (ISO 7-1) male.

Important!

After connection the installer must check that the hose is not kinked, subjected to abrasion or permanently deformed. The installer must check also that the hose is not near (or in contact) with any hot surfaces.

- The hose assembly shall be as short as practicable and comply with relevant AS5601 / NZS5261 requirements.

Leak-testing and flame-testing the cooker

After installing the freestanding cooker and connecting the gas supply:

- 1 Using a suitable leak detection fluid solution, check each gas connection one at a time by brushing the solution over the connection.
The presence of bubbles will indicate a leak. If there is a leak, tighten the fitting and then recheck for leaks.

Important!

Do not use a naked flame to test for leaks.

- 2 Adjust the test point pressure or supply pressure to the value that is appropriate for the gas type.
- 3 Test the operation of the appliance:
 - Turn on the appliance gas controls and light each burner individually and in combination. Check for a well-defined blue flame without any yellow tipping. If any abnormality is evident, then check that the burner cap is located properly and the injector nipple is aligned correctly.
 - Check the minimum burner setting by quickly rotating the gas control knob from the maximum to the minimum position. The flame must not go out. If you need to adjust the setting, see section 'Adjusting the minimum burner setting'.
- 4 If satisfactory performance cannot be obtained, the installer shall check the installation and notify the local gas supply authority for a gas supply problem, or if it is an appliance problem, our Customer Service Centre should be called to obtain the nearest authorized Service Agent.

Converting to a different gas type

This appliance is suitable for use with Natural gas or LPG (check the “gas type” sticker attached to the appliance). To convert from one gas type to another, you need to replace the injectors, and then adjust the minimum burning setting. See instructions on pages following.

Important!

- *If you are converting the cooker from Natural gas to LPG, remove the gas pressure regulator before connecting the cooker to the gas supply and replace with the test point adaptor supplied with the conversion kit.*
- *If you are converting the cooker from LPG to Natural gas, remove the test point adaptor before connecting the cooker to the gas supply and replace with the gas pressure regulator supplied with the conversion kit.*

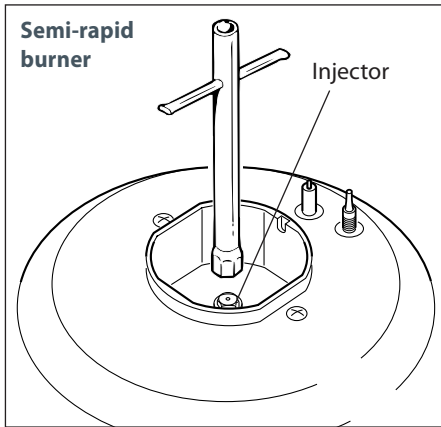

Fig. 14a

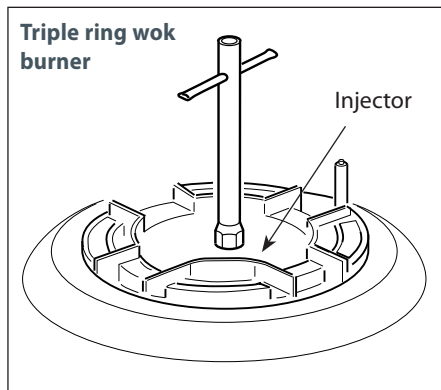

Fig. 14b

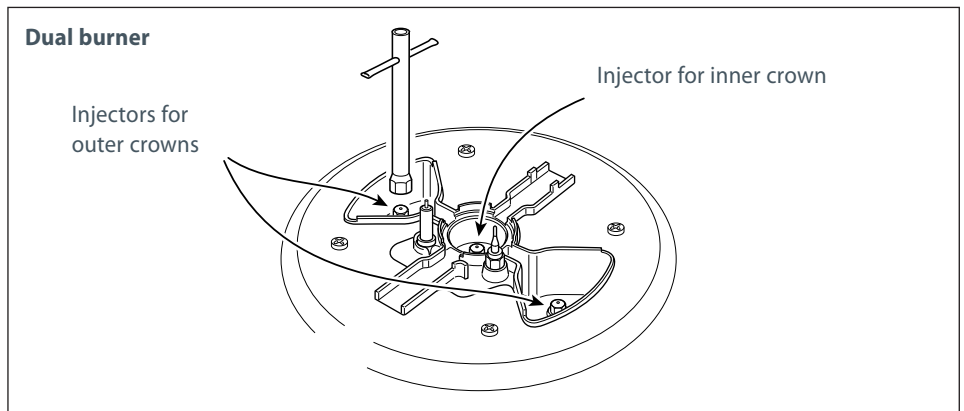

Fig. 14c

Replacing the injectors

If the injectors are not supplied, contact your nearest Fisher & Paykel Authorised Service Centre.

To replace the injectors:

- 1 Remove the trivets and burners from the cooktop.
- 2 Using a spanner, remove the injectors (Figs.14a,14b,14c) and replace them with the ones according to the gas type (see the 'Table for the choice of injectors').
- 3 Fix the warning label (supplied with the conversion kit) at the back of the cooker, near the gas inlet connections. This label states that the gas cooktop has been converted for use with LPG/Natural gas.

The burners are designed so that adjustment of primary air is not required.

Adjusting the minimum burner setting

- Check whether the flame spreads to all burner ports when the burner is lit with the gas valve set to the minimum position. If some ports do not light, increase the minimum gas rate setting.
 - Check whether the burner remains lit even when the gas valve is turned quickly from the maximum to the minimum position. If the burner does not remain lit, increase the minimum gas rate setting.
- To adjust the minimum gas rate setting:

Semi-rapid and triple-ring wok burners

- 1 Light the burner.
- 2 Set the gas valve to the  position.
- 3 Remove the knob.
- 4 Using a small flat screwdriver, turn the screw (see Fig.15a) to the correct regulation.

Inside crown of dual burner

- 1 Light the dual burner.
- 2 Set the gas valve to the  position.
- 3 Remove the knob.
- 4 Using a small flat screwdriver, turn the screw "H" (see Fig.15b) to the correct regulation.

Outside crowns of dual burner

- 1 Light the dual burner.
- 2 Set the gas valve to the  position.
- 3 Remove the knob.
- 4 Using a screwdriver, turn the screw "G" (see Fig.15b) to the correct regulation.

For LPG gas, tighten the adjustment screws completely.

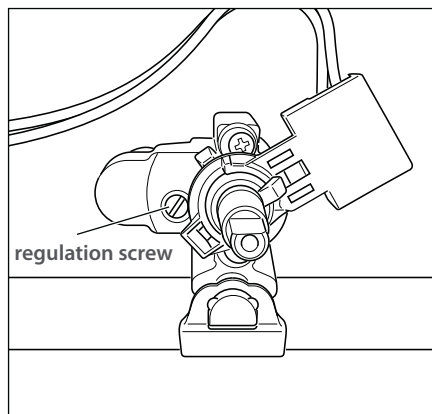

Fig. 15a Adjusting the minimum burner setting—semi-rapid and triple-ring wok burners

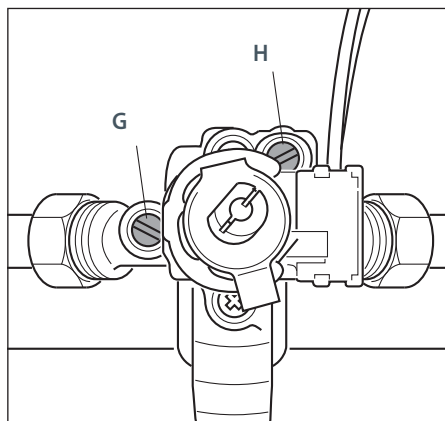

Fig. 15b Adjusting the minimum burner setting—Dual burner

Table for the choice of injectors

		Natural gas		LPG	
Test Point Pressure [kPa]		1.0		2.75	
BURNER		Injector Orifice Dia. (mm)	Gas Consumption [MJ/h]	Injector Orifice Dia. (mm)	Gas Consumption [MJ/h]
Semi-rapid		1.12	6.30	0.70	6.30
Triple-ring wok		1.60	12.70	0.95	11.90
Dual	inner crown	0.85 (no.1 central)	3.60 (*)	0.50 (no.1 central)	3.20 (*)
	outer crowns	1.15 (no.2 outer)	16.00 (#)	0.62 (no.2 outer)	13.00 (#)

(*): Power calculated with inner crown operating.

(#): Power calculated with inner and outer crowns operating.

Lubrication of the gas valves

The gas valves should only be lubricated by a qualified technician.

Important!

All installation, maintenance and conversion of the appliance must be done using original factory parts. The manufacturer declines any liability if these correct parts are not used.

Connecting the power supply cable

To connect the power supply cable to the cooker:

- 1 Remove the four screws that hold shield "A" behind the cooker.
- 2 Open the cable clamp "D" completely.
- 3 Check the position of the U bolts on the terminal block "B" (Fig. 16a) corresponds to the connection diagrams in Fig. 16b and Fig. 16c.
- 4 Insert the power supply cable into the cable clamp "D" and into the cable protector "C". The supply cable must be of a suitable size for the current requirements of the appliance.
 - This cooker must be connected to the power supply using V105 insulated cable.
 - This cooker must be earthed.
- 5 Connect the phase and earth cables to terminal "B" according to Figs. 16b and 16c.
- 6 Tighten the power supply cable and fix it with the cable clamp "D".
- 7 Re-mount shield "A", securing it tightly with the four screws.

Note: the earth conductor must be left about 30 mm longer than the others.

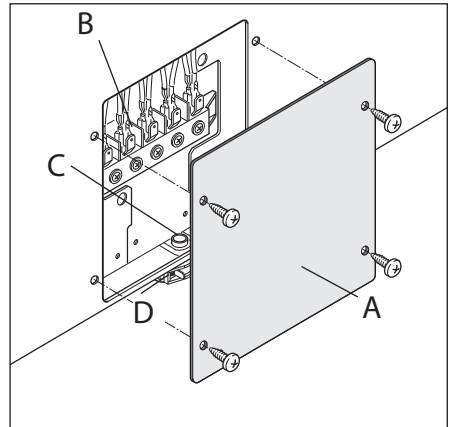

Fig. 16a Accessing the terminal block

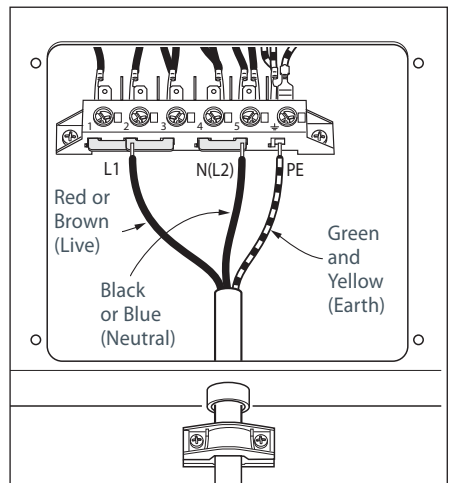

Fig. 16b Electrical connection

Power supply

220 - 240V ~ 5300W 50Hz

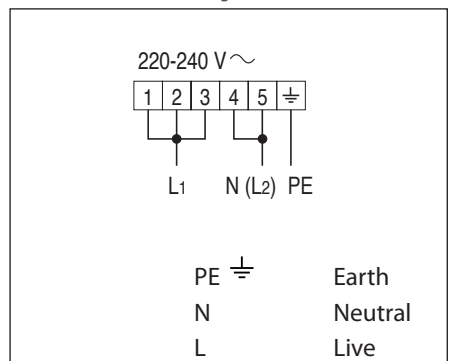
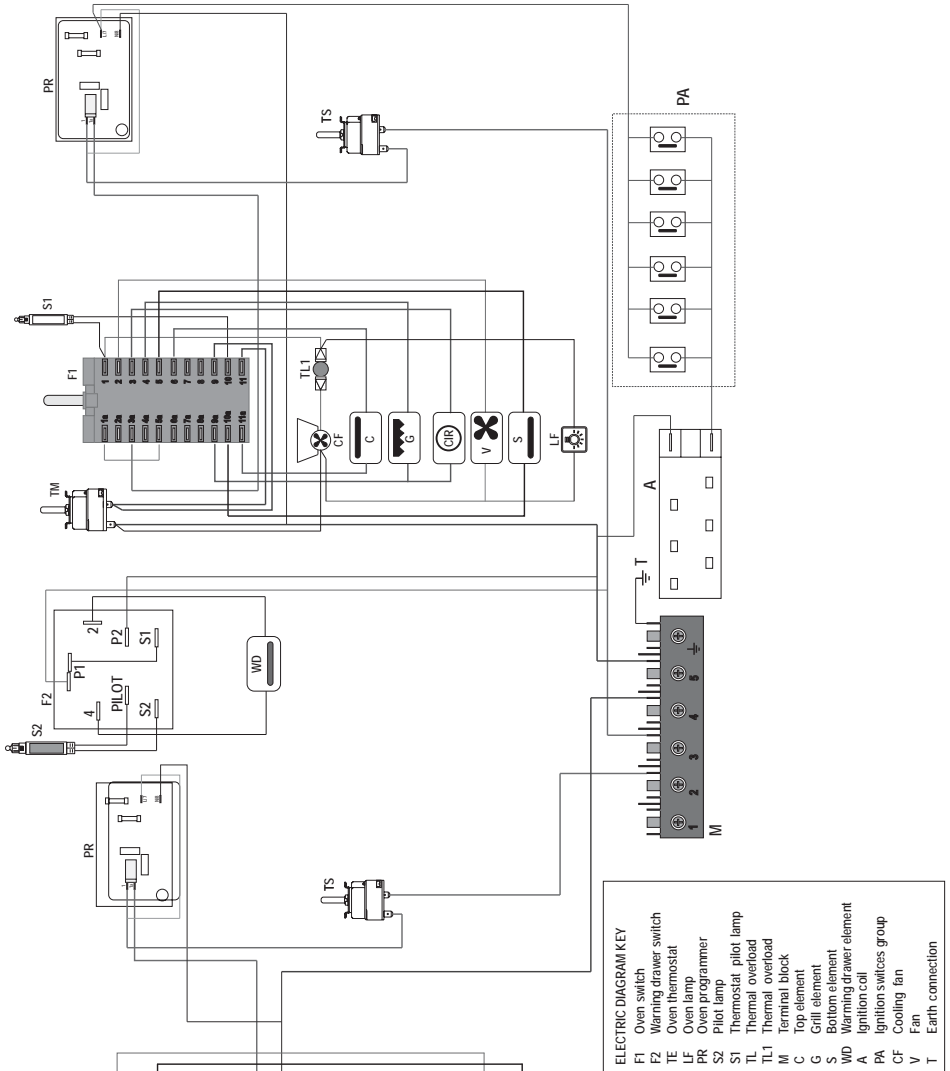

Fig. 16c Connection diagram

Wiring diagram



20 Introducing your cooker

Thank you for buying a Fisher & Paykel freestanding cooker. Once it is installed and ready to use, you will want to know everything about it to make sure you get excellent results right from the start. This guide introduces you to all its special features. We recommend you read the whole guide before using your new cooker, for both safety and cooking success.

For more information, go to www.fisherpaykel.com

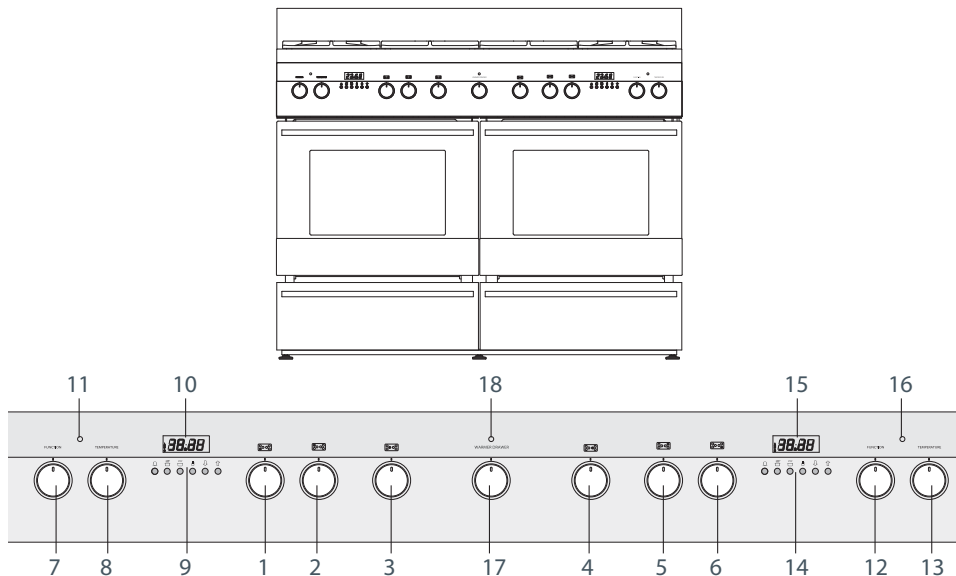

Fig. 17 Cooker control panel

Gas cooktop controls:

- 1 Front left triple-ring wok burner control knob
- 2 Rear left semi-rapid burner control knob
- 3 Central left dual burner control knob
- 4 Central right dual burner control knob
- 5 Rear right semi-rapid burner control knob
- 6 Front right triple-ring wok burner control knob

Right oven controls:

- 12 Function knob
- 13 Temperature knob
- 14 Control buttons
- 15 Clock display
- 16 Oven temperature indicator light

Warmer drawer (left drawer only) controls:

- 17 Warmer drawer control knob
- 18 'Warmer drawer on' indicator light

Left oven controls:

- 7 Function knob
- 8 Temperature knob
- 9 Control buttons
- 10 Clock display
- 11 Oven temperature indicator light

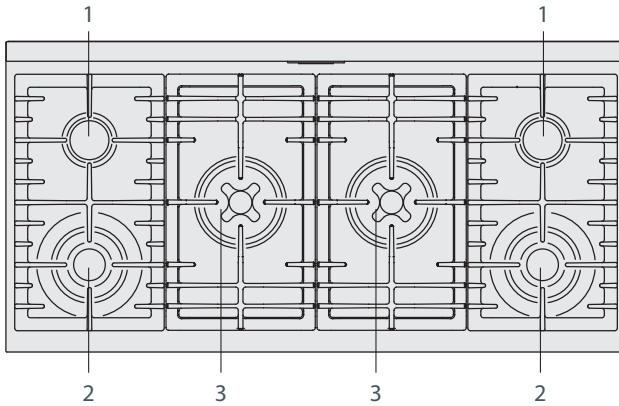









Fig. 18 Cooktop layout

- 1 Semi-rapid burner
- 2 Triple-ring wok burner
- 3 Dual burner

Gas burners

The knob controls the flow of gas through the safety valve.

-  /OFF = closed valve
-  = maximum flow
-  = minimum flow

You can choose to cook at any heat between  and , but never between  and  /OFF.

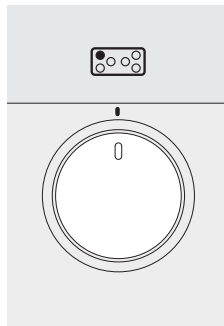

Fig. 19 Burner control knob

Before using your cooktop

Before using your new cooktop, please:

- Read this user guide, taking special note of the 'Safety and warnings' section.
- Switch the power to the cooker on at the wall.
- Make sure all burner control knobs are turned off.

Using the gas burners (semi-rapid and triple-ring wok)

- 1 Choose the control knob for the burner you want to use.
- 2 Press the knob down gently and turn it anticlockwise to the ● position. The ignitors on all the burners will spark.
Hold down the knob for approximately 10 seconds after the burner has lit. Releasing the knob too soon will extinguish the flame.
- 3 Adjust the flame anywhere between the ● and ● positions. Do not adjust the flame between ● and 0 /OFF.
 - Note: if the burner does not light within 15 seconds, turn the control knob off and wait at least one minute before trying again.
- 4 To switch the burner off, turn the knob clockwise until you hear the safety click.
- 5 After use, always turn the knobs to the 0 /OFF position.

Flame failure safety feature

The flame failure probe cuts off the gas supply to the burner if the flame is blown out.

When lighting the burner, hold down the knob for approximately 10 seconds after the burner has lit. Releasing the knob too soon will extinguish the flame.

If the flames are accidentally extinguished, turn off the burner and do not try to light it again for at least one minute (to allow the gas to disperse).

Using the dual gas burners

These burners are very versatile. By controlling the inner crown and the two outer crowns separately, you can use them when you need a small burner or a high-powered one.

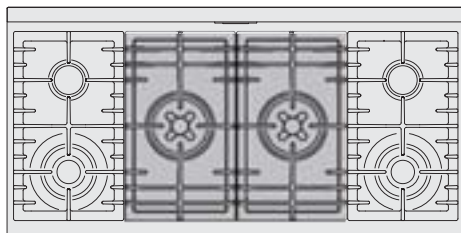

Fig. 20 Dual crown burners

- To use the inner crown only, press down the control knob before turning it, then adjust the flame anywhere between ☉ and ☉. Do not adjust the flame between ☉ and 0 / OFF.
- To use the inner and outer crowns together, press down the control knob before turning it, then adjust the flame anywhere between ☉ and ☉.

If a burner does not light

Check that:

- The cooker is plugged in and the electricity is switched on.
- The gas is turned on.
- The gas bottle is not empty (if you are using bottled gas).
- You have held down the knob for at least 10 seconds.
- The ignitors are sparking. If the ignitors are not sparking, they may be dirty or wet. Clean them with a toothbrush and methylated spirits, as shown in Fig.21.

If the flame is irregular

If the flame is yellow or irregular, check that the burner parts, including the burner cap, are:

- clean and dry.
- positioned correctly. See 'Care and cleaning'.
- See also 'Troubleshooting'.

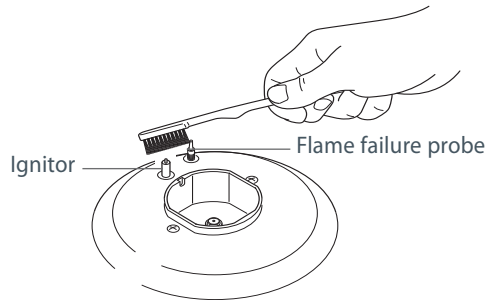

Fig. 21 Cleaning the probe and ignitor

Using the cast-iron griddle

- The griddle is ideal for cooking a variety of foods.
- We recommend using the griddle on the dual burners only.
- Heat the griddle for a few minutes before using.
- To reduce splatter and smoking, brush the food rather than the griddle with oil.
- Cook steak and chargrilled vegetables at high temperatures on the ribbed part of the griddle.
- Griddle scones, pancakes, pikelets, polenta and eggs are best cooked slowly at medium to low temperatures on the flat part of the griddle.
- See 'Care and cleaning' for instructions on how to clean your griddle.

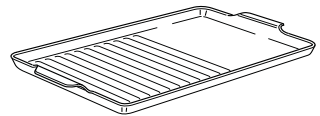

Fig. 22 Enamelled cast-iron griddle

Important!

Prolonged cooking with the griddle at high temperatures may damage the cooktop.

Matching cookware to burner

Use flat-bottomed pans, and make sure that they match your burner, as shown in the following table. A small pot on a large burner is not efficient.

Diameters of pans which may be used on the cooktop

Burners		Minimum	Maximum
Semi-rapid		16 cm	24 cm
Dual	with only inner crown operating	12 cm	24 cm
	with both inner and outer crowns operating	26 cm	28 cm
Triple-ring wok		26 cm	28 cm
		Maximum diameter for wok pans: 36 cm	

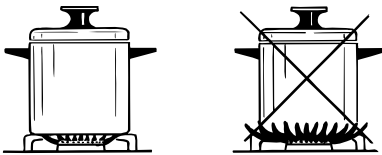

Fig. 23a Correct and incorrect matching



Fig. 23b Efficient and inefficient saucepan bottoms

Using the wok stand

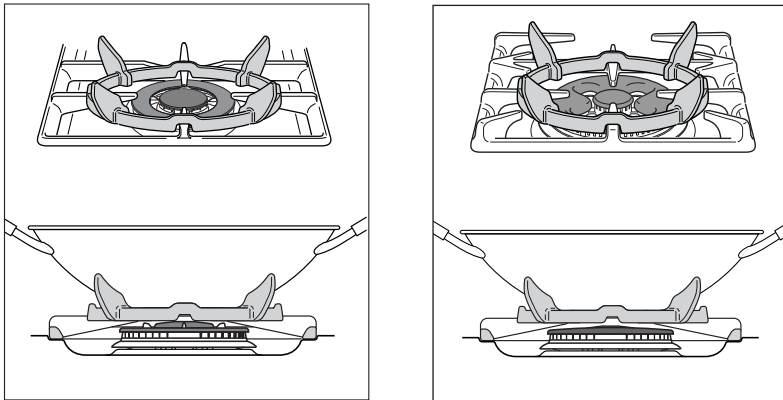

Fig. 24 Correct placement of wok stand

Important!

- Place the wok stand as shown.
- Always use the wok stand for wok cooking. Using a wok without the stand may cause the wok to tip or the burner to operate incorrectly.
- Do not use the wok stand for ordinary, flat-bottomed saucepans.
- Only use the wok stand on the dual or triple-ring wok burners.
- The cooktop becomes very hot during operation. Keep children well out of reach.

Problem	Possible solutions
A burner does not light.	<p>Check that the power to the cooker is switched on at the wall.</p> <p>Check the gas supply valve is turned on and the supply to the house is working. You should hear the gas when you turn a burner on.</p> <p>Check the gas bottle is not empty.</p> <p>The ignitors may be dirty. Clean them with a toothbrush and methylated spirits.</p> <p>The burner parts may not be located properly. Check the assembly and make sure the burner cap is sitting flat.</p>
My burner flames are yellow or hard to start.	<p>The burner parts may not be located properly. Check the assembly and make sure the burner cap is sitting flat.</p> <p>If you use bottled gas, this may indicate you are getting near the end of the bottle.</p> <p>Check the burner parts are clean and dry.</p> <p>The gas pressure may not be at the correct level. Check with your service person or installer.</p> <p>Your cooker may not be set up for the gas you are using. Check this with your service person or installer.</p>
One of my burners has an uneven flame.	<p>Check the burner parts are clean and dry. Check the assembly and make sure the burner cap is sitting flat.</p>
The flame goes out at low settings.	<p>The gas supply pressure may be low. Check this with your service person or installer.</p> <p>The low setting may have been adjusted incorrectly. Check this with your service person or installer.</p> <p>If you use bottled gas, this may indicate you are getting near the end of the bottle.</p>
My burners do not turn down much (when running on bottled gas or LPG).	<p>Your cooktop may not have been adjusted correctly. Check this with your service person or installer.</p>
The flame tips are very yellow.	<p>Call your service person to service the cooker.</p>
There are objectionable odours.	<p>Call your service person to service the cooker.</p>
The flame appears to lift off the burner.	<p>Call your service person to service the cooker.</p>
There is an electricity failure.	<p>If there is an electricity failure, you can still use your cooktop. Light the burners by holding a match close to the side of the burner and turning the control knob to the ● (High) position. Wait until the flame is burning evenly before adjusting.</p>

26 Using your ovens for the first time

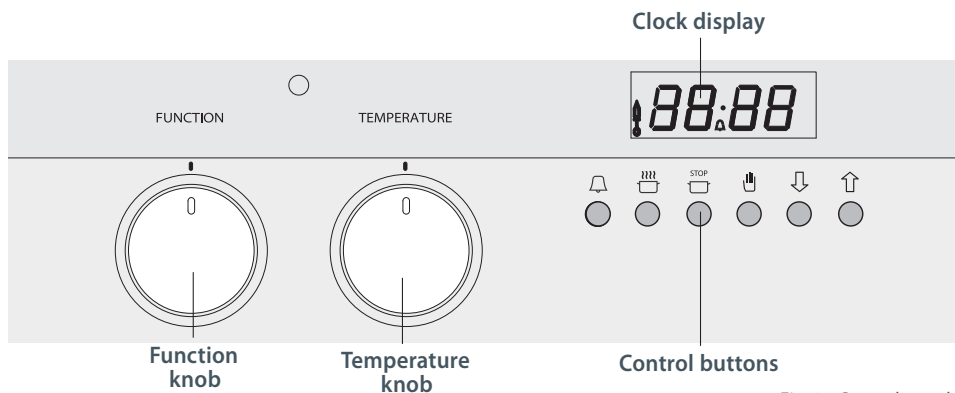





Fig. 25 Control panel

Before using your new oven, please:

- 1 Read this user guide, taking special note of the 'Safety and warnings' section.
- 2 Remove all accessories and packaging. Peel the protective film off all surfaces and accessories.
- 3 Set the clocks. The ovens will not work until the clocks have been set.
- 4 Condition the ovens:
 - Put in the shelves and trays. Fit them between the metal runners or on the sliding shelf supports, with the safety stop notch down and at the back. (If the side racks and sliding shelf supports are not already fitted, see 'Care and cleaning' for how to do this).
 - Heat the ovens on maximum for:
 - 60 minutes in the  position
 - 30 minutes in the  position
 - 15 minutes in the  position
 - There will be a distinctive smell while you are doing this. This is normal, but make sure your kitchen is well ventilated during the conditioning.
- 5 Once cooled, wipe out the ovens with a damp cloth and mild detergent, and dry thoroughly.

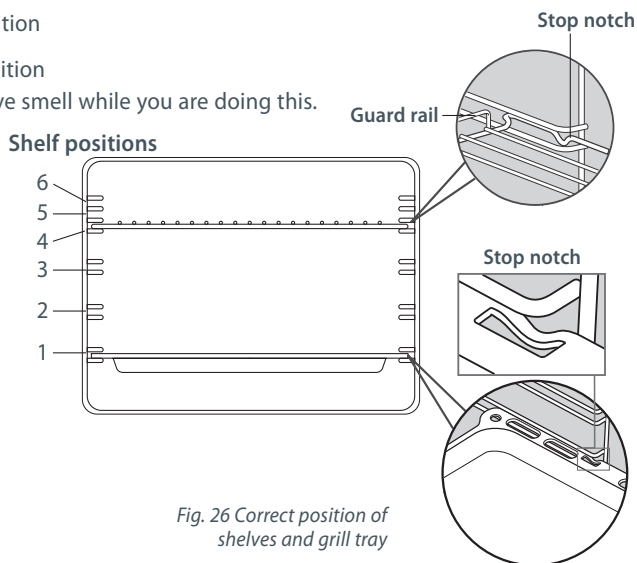







Fig. 26 Correct position of shelves and grill tray

Buttons

-  sets the timer
-  sets the cooking time for automatic cooking
-  sets the stop time for automatic cooking
-  sets the clock, returns oven to manual mode, cancels automatic cooking
-  decreases time and beep volume
-  increases time

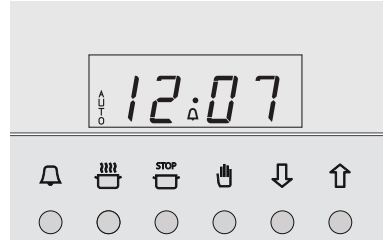







Fig. 27 Clock display and control buttons

Illuminated symbols

	If the display shows	It means that...	For more information
A U T O	flashing with 	The clock needs to be set.	See instructions below.
	steadily lit	The oven is set for automatic cooking.	
	flashing and beeping	Automatic cooking has finished or has been set incorrectly (the stop time is before the time of day).	See section 'Automatic cooking'
	steadily lit	The timer is set.	See section 'Using the electronic timer'
	flashing and beeping	The set time is up.	

To set the clock

When the power to the oven is turned on or restored after a power failure,  and AUTO will flash in the display.

- 1 Press .
- 2 Press  and  until you have the correct time of day.

Oven controls

- 1 Select the function using the function knob. The oven lights will come on.
- 2 Select the temperature using the temperature control knob. The oven temperature indicator light, above the temperature knob on the control panel, will glow until the oven has reached the set temperature, and then it will go out.
- 3 When you have finished cooking, turn the function and temperature control knobs to the off O position.

Note: press the  button if **AUTO** is flashing or steadily illuminated.

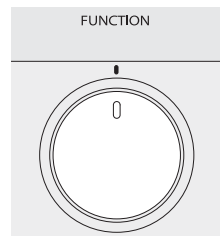

Fig. 28 Function knob

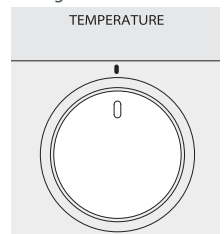

Fig. 29 Temperature knob



Only the oven light comes on. It remains on in all the cooking functions.



The upper and lower heating elements come on. BAKE is the traditional method of cooking. It is best to cook on only one shelf at a time in this function.



The grill at the top of the oven comes on. Preheat for five minutes. Use with the oven door closed and the temperature knob between 50 °C and 225 °C max. Do not grill for longer than 30 minutes at any one time. For best results, use the topmost shelf position when you want quick browning (eg toast).



Only the oven fan comes on. Use with the temperature knob set to O. The fan circulates air around the oven, speeding up the defrosting process by approximately 30%.
Note: this function is not for cooking food.



The circular heating element and the fan come on. The oven set on FAN FORCED can cook several different foods together. Use FAN FORCED for multi-shelf cooking.



Both the grill and the fan come on. Use with the oven door closed and the temperature knob between 50 °C and 225 °C max.



The upper element, the circular element and the fan come on. Set between 50 °C and 140 °C.
Note: this function is not for cooking food.

**FAN BAKE**

The upper and lower heating elements and the fan come on.

Important!

Safe food handling: leave food in the oven for as short a time as possible before and after cooking or defrosting. This is to avoid contamination by organisms which may cause food poisoning. Take particular care during warmer weather.

Notes on baking and roasting:

- **Only use the fat filter for roasting. Remove before baking. Always clean the filter after cooking.**
- Preheat the oven before baking.
- Do not place anything, including water or ice, on the oven floor.

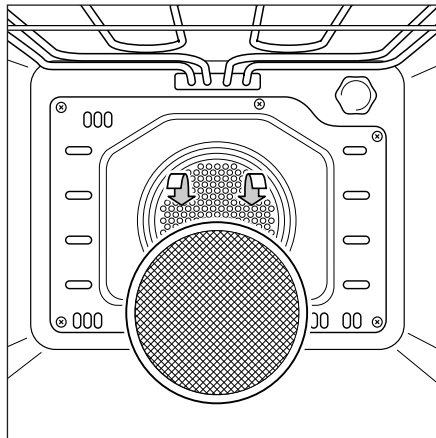

Fig. 30 Fat filter

30 Using the electronic timer

You can use the timer at any time, even when the oven is not in use.

Important!

The timer does NOT turn the oven off.



To set the timer

- 1 Press . will show and the symbol will start flashing.
 - 2 Press and to set the time you want (up to 23 hours and 59 minutes, in 1-minute steps).
- After a few seconds, the clock will show the time of day with the symbol steadily lit. The timer is now counting down.

To check the remaining time

Press .

To cancel the timer

- 1 Press .
 - 2 Press until the time is reset to .
- After a few seconds, the clock will show the time of day.

When the set time is up

- The timer will beep and the symbol will flash. Press to stop the beeping and turn the timer off.
- After a few seconds, the clock will show the time of day.

To adjust the beep volume



Press to hear the next volume level. The last one selected will be stored.

To set the oven for automatic cooking



1 Set the oven:

- Check the clock shows the correct time (eg 12:07).
- Select the function and set the temperature.
The oven will turn on.

2 Set the cooking time:

- Decide how long the food will take to cook, allowing time for preheating if necessary (eg 40 minutes).
- Press .
- Use  and  to set the cooking time. AUTO will show in the display.



3 Set the stop time:

- Decide when you want your food to be ready by (eg 13:30).
- Press .
- Use  and  to set the stop time.



You can turn the oven on manually and set it to turn off automatically by setting the stop time (step 3 above).

When automatic cooking is set

- If there is time before cooking starts, the oven will turn off and the current time of day and AUTO will show in the clock display, indicating that the oven is set for automatic cooking. Note: the cooling fan may stay on.
- The oven will automatically turn on at the required time (eg 12:50) and turn off at the set stop time (eg 13:30).
- To see the remaining cooking time, press .
- To see the set stop time, press .
- To cancel automatic cooking, press  and turn the function and temperature knobs to 0 (off).

When the stop time is reached

- The oven will turn off, the timer will beep and AUTO will flash.
- 1 Press  to stop the beeping and return the oven to manual mode.
 - 2 Turn the function and temperature knobs to 0 (off).

32 Using your warmer drawer

- The warmer drawer is on the left-hand side. You can heat it from 30 °C to 120 °C. It also has a moisture control selector.

Before using your warmer drawer, please:

- Condition it by heating it on maximum for about two hours.
- Once cooled, wipe it out with a damp cloth and mild detergent, and dry thoroughly.

Important!

- *Only use the warmer drawer for keeping hot food warm.*
- *Safe food handling: leave food in the oven for as short a time as possible before and after cooking or defrosting. This is to avoid contamination by organisms which may cause food poisoning. Take particular care during warmer weather.*
- *Do not place food in unopened containers into the warmer drawer, as these may burst.*
- *Do not use plastic containers.*
- *Do not line the drawer with aluminium.*

To use the moisture selector

- To keep food moist, slide the selector to the left. This closes the vents.
- To keep food crisp, slide the selector to the right. This opens the vents.

Reversible rack

Position the reversible rack as shown in Figs. 33a and 33b.

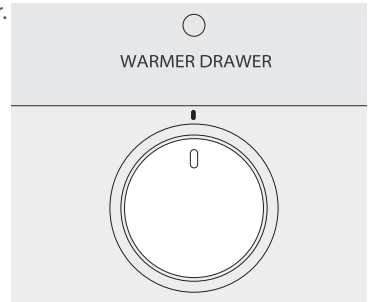

Fig. 31 Warmer drawer knob and indicator light

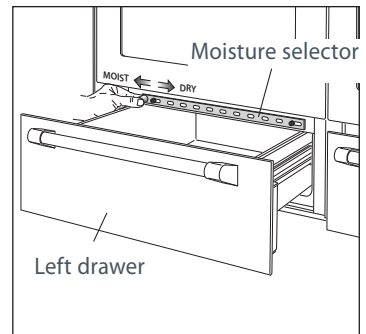

Fig. 32

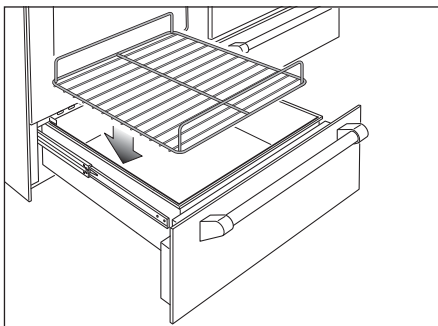

Fig. 33a

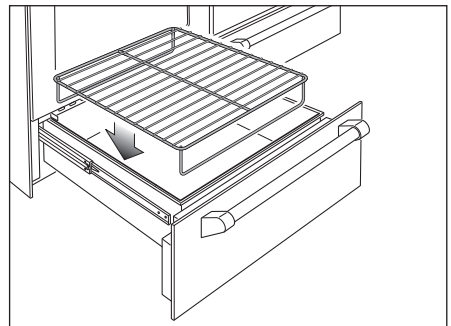

Fig. 33b

Important!

Before you start cleaning your cooker, please:

- *Read these cleaning instructions and the 'Safety and warnings' section at the start of this user guide.*
- *Turn the power to the cooker off at the wall.*
- *Make sure the cooker is a safe temperature to touch.*
- *Do not use a steam cleaner.*
- *Do not keep flammable substances in the ovens or drawers.*

General advice

- Wipe down the cooktop and wipe out the ovens after every use.
- Wipe up spills. Avoid leaving alkaline or acidic substances (such as lemon juice or vinegar) on the oven surfaces.
- Do not use cleaning products with a chlorine or acidic base.

Cleaning the outside of the cooker

Important!

- *Do not use abrasive cleaners, cloths or pads on the outside surfaces of the cooker.*
- *Immediately wipe off any caustic cleaners if they are spilled onto the oven door handles.*

Wipe the cooker's outside surfaces often, using warm water and a mild household detergent. The stainless steel may also be cleaned with a suitable cleaner and polish.

Note: if you choose to use a commercial stainless steel cleaner, please read the label to make sure it does not contain chlorine compounds as these are corrosive and may damage the appearance of your cooker.

Cleaning the gas cooktop

Maintenance Period	Description
Daily	• Clean gas cooktop as per following instructions.
Monthly	<ul style="list-style-type: none"> • Remove all burner parts, and clean using a non-abrasive detergent. Rinse in cold water, dry thoroughly, and replace. • Clean the ignitor and probe carefully, using a toothbrush and methylated spirits.
Every 3-4 years	• Contact your local authorised gas Service Agent to perform a thorough check on all gas components on the gas cooker.

Cleaning the burner parts and trivets

- You can remove and clean these parts with hot soapy water or non-abrasive detergents. Clean spills regularly before they become burnt on. Do not wash these parts in a dishwasher.
- After cleaning, check that the burners and their flame spreaders are dry before replacing correctly.
- It is very important to check that the burner flame spreader and the cap have been correctly positioned. Failure to do so can cause serious problems.
- Note: to avoid damage to the electric ignition, do not try to light a burner without all burner parts in place.

Replacing the burners

- Carefully replace the burner parts as per the following Figs. Check that:
 - The ignitor is always clean to ensure trouble-free sparking.
 - The probe is always clean to ensure correct operation of the safety valves.

Note: both the ignitor and probe must be very carefully cleaned using a toothbrush and methylated spirits.

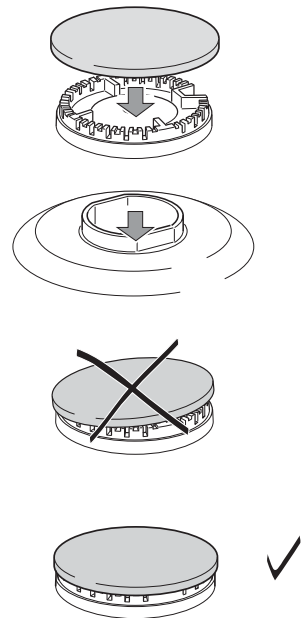
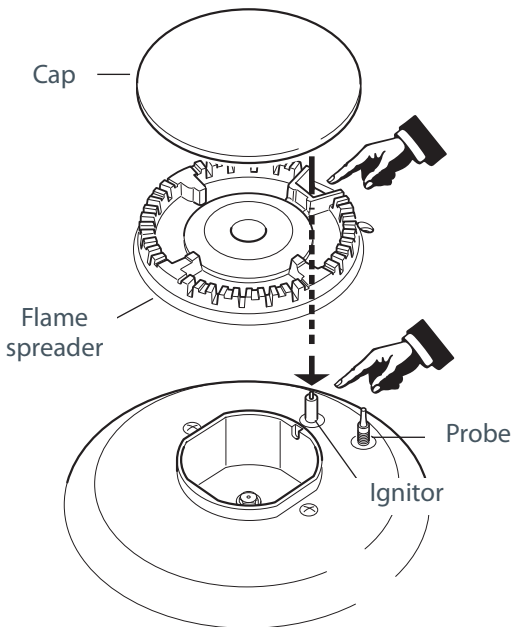

Fig. 34 Correct line-up of semi-rapid burner parts

Fig. 35 Replacing the semi-rapid burner caps

Replacing the triple-ring wok burner

Fit the burner ring to the housing as shown by the arrow in the Fig. following. Make sure the burner is not able to rotate (Fig.36).

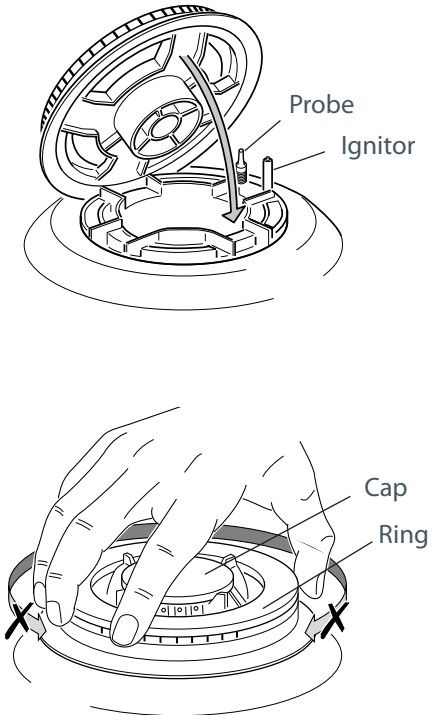

Fig. 36 Correct positioning of cap and ring - triple-ring wok burner

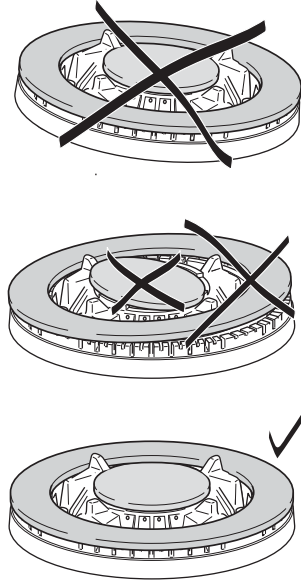

Fig. 37 Incorrect and correct positioning of cap and ring - triple-ring wok burner

Replacing the dual burners

- Ensure that you replace the dual burner correctly; the burner rib must be fitted as shown by the arrows in Fig.38a.
- Position the small central cap in its housing as shown by the arrows in Fig.38b.
- Position the big cap in its housing as shown by the arrows in Fig.38c.

Important!

Never unscrew the burner screws.

Cleaning the cast-iron griddle

- Leave the griddle to soak before cleaning. Scrape away any food residue and wash in warm soapy water.
- Rinse and dry the griddle thoroughly.

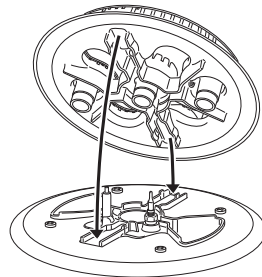

Fig. 38a Fitting the burner rib

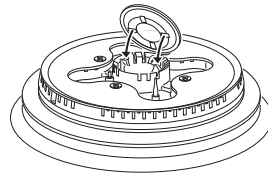

Fig. 38b Positioning the central small cap

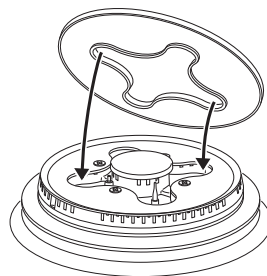

Fig. 38c Positioning the big cap

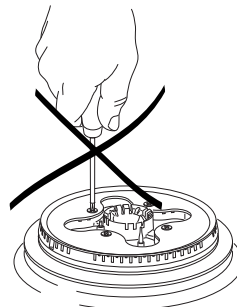

Fig. 38d Do not unscrew burner screws

Cleaning the inside of your ovens

- Do not use abrasive cleaners, cloths or pads to clean the enamel.
- If you have purchased and installed catalytic panels, do not use any oven cleaners, abrasive cleaners, ammonia-based cleaners, products containing acids or alkalis or detergents on them.

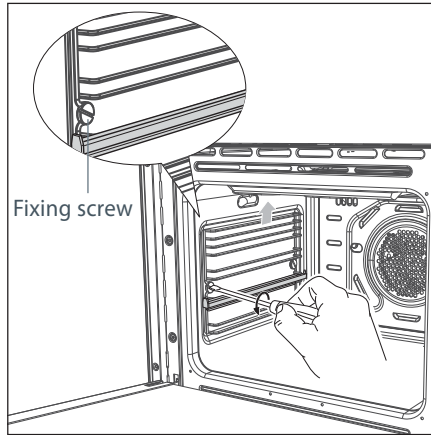

Fig.39 Removing the side racks (and catalytic panels if installed)

To make cleaning easier, you can remove the side racks, the oven door, and the fat filter.

Drop-down grill element

- To lower the grill element: use a flat-head screwdriver or a small coin to loosen the element fixing screw.
- When you have finished cleaning the oven ceiling, raise the grill element and screw the element fixing screw back onto the stud. Make sure that the fixing screw is tightened and the element is held securely in place.
- The grill element itself is self-cleaning.

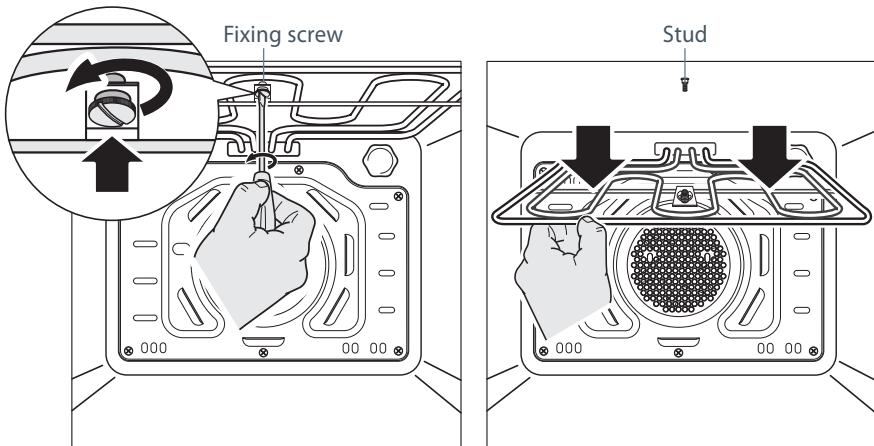

Fig.40 Drop-down grill element

Cleaning the enamel cavity

Do not use abrasive cleaners, cloths or pads to clean the enamel. Clean the enamel on the inside of an oven when it has cooled down, using household detergents or an ammonia-based cleaner. You may use 'off the shelf' oven cleaners, if you carefully follow the manufacturers' instructions.

Caring for the catalytic panels

- The catalytic panels are not supplied with the cooker, but purchased and installed optionally. Contact your local Fisher & Paykel dealer for details.
- The catalytic panels are covered with a special microporous enamel which absorbs and does away with oil and fat splashes during normal cooking over 200 °C. If, after cooking very fatty foods, the panels remain dirty, heat the oven on maximum for an hour to an hour and a half, and they will self-clean. The side panels are reversible. Make sure that you replace them with the arrow up, and on the correct side. To remove the side catalytic panels, you first need to unscrew the side racks. See Fig. 39.

When you replace the panels, make sure that:

- The arrows are pointing upwards.
- Then screw the side racks back onto the oven wall.

Note: in some models, the back panel of the oven is also a catalytic liner, but this is not reversible and should not be removed.

Cleaning the fat filter

Clean the fat filter after every use. If the filter is not cleaned, it will block and shorten the life of the fan element. If it is lightly soiled, place the filter in a dishwasher on normal wash. If the filter is very dirty, place in a saucepan with either two tablespoons of clothes washing powder, or one tablespoon of dishwashing powder. Bring to the boil and leave to soak for at least 30 minutes.

Rinse the filter in clean water and dry.

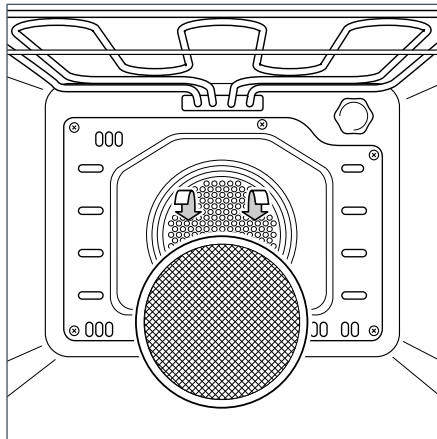

Fig. 41 Fat filter

Sliding shelf supports

The telescopic sliding shelf supports make it safer and easier to insert and remove the oven shelves and trays. They stop when they are pulled out to the maximum position. Wipe the supports with a damp cloth and a mild detergent only. Do not wash them in the dishwasher, immerse them in soapy water, or use oven cleaner on them.

To remove the sliding shelf supports:

- 1 Remove the side racks by unscrewing the fixing screws (Fig. 39).
- 2 Lay down the sliding shelf support and side racks, with the sliding shelf support underneath.
- 3 Find the safety locks. These are the tabs that clip over the wire of the side rack (arrow 1 in Fig. 42).
- 4 Pull the safety locks away from the wire to release the wire (arrow 2 in Fig. 42).

To re-fit the sliding shelf support onto the side racks:

- 1 Screw the side rack onto the oven wall.
- 2 Fit the sliding shelf support onto the top wire of a rack and press (Fig. 43). You will hear a click as the safety locks clip over the wire.

Important!

The sliding supports can only be used on shelf positions 1,2 and 3.

When fitting the sliding shelf supports, make sure that you fit:

- *the slides to the top wire of a rack. They do not fit on the lower wire.*
- *the slides so that they run out towards the oven door, as shown in Fig. 43.*
- *both sides of each pair of shelf slides.*
- *both sides on the same level. Note: you cannot fit the sliding shelf supports to the top shelf position.*

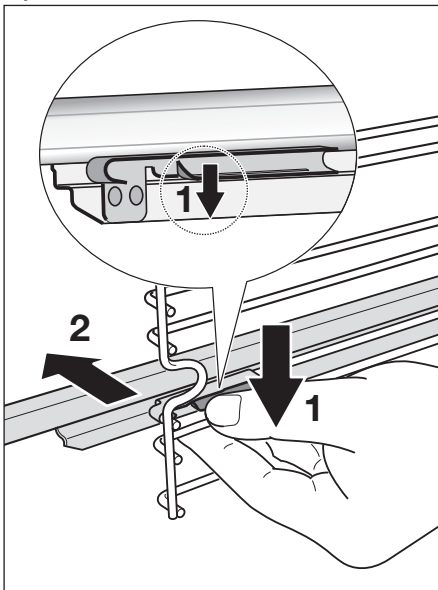

Fig.42 Removing the sliding shelf supports

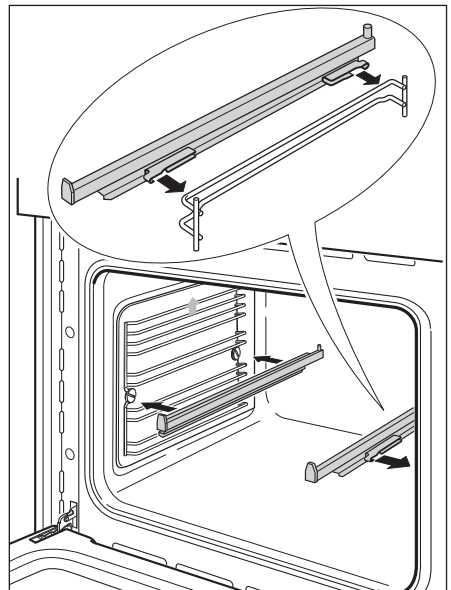

Fig.43 Refitting the sliding shelf supports

Cleaning the oven door glass

Do not use harsh abrasive cleaners or sharp metal scrapers to clean the oven door glass since they scratch the surface, which may result in shattering of the glass.

Removing the inner and middle panes of glass

The oven door has three panes of glass. To clean these, you need to remove the inner and middle panes.

- 1 Lock the door open:
 - Fully open the oven door (Fig. 44a).
 - Fully open the lever "A" on the left and right hinges (Fig. 44b).
 - Gently close the door (Fig. 44c) until the left and right hinges are hooked to part "B" of the door (Fig. 44b).

- 2 Remove the inner pane:
 - Remove the seal "G" by unhooking the three fixing hooks (Fig. 44d).
 - Gently pull out the inner pane of glass (Fig. 44e).
 - Clean the glass with an appropriate cleaner. Dry thoroughly, and place on a soft surface.

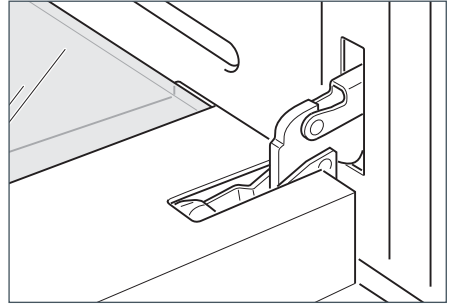

Fig.44a

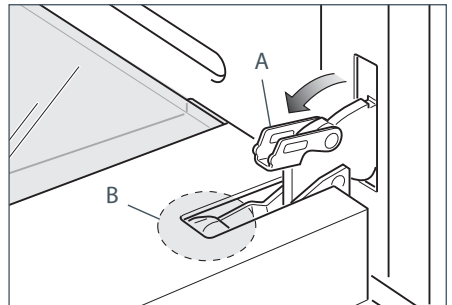

Fig.44b

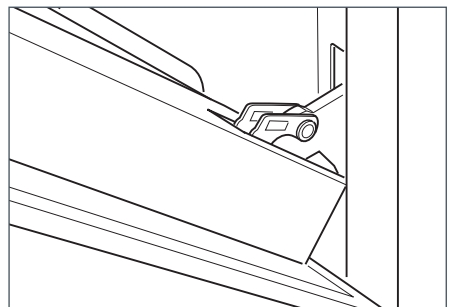

Fig.44c

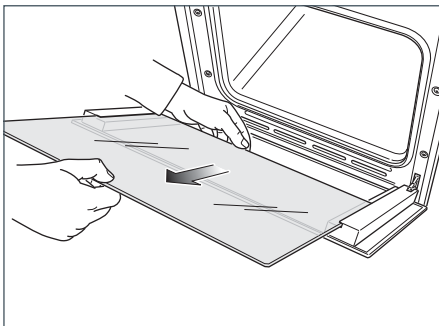

Fig.44e

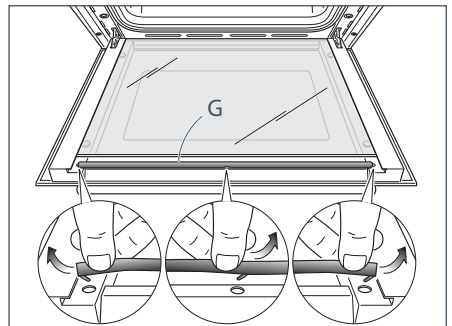

Fig.44d

- 3 Remove the middle pane:
 - Gently unlock the middle pane of glass from the bottom clamps by moving it as in Fig. 45b.
 - Gently lift the bottom edge of the pane (arrow 1 in Fig. 45c) and remove it by pulling it out from the top clamps (arrow 2 in Fig. 45c).
 - Clean the glass with an appropriate cleaner. Dry thoroughly, and place on a soft surface.
- 4 Now you can also clean the inside of the outer glass.

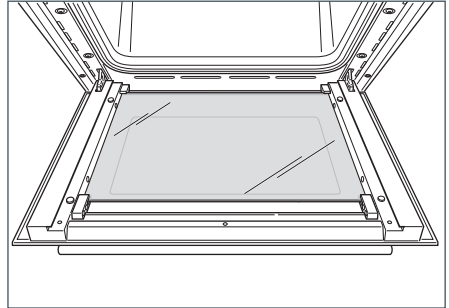

Fig.45a

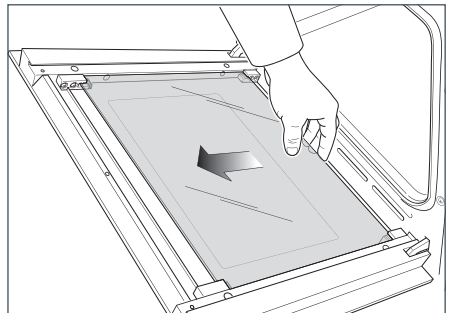

Fig.45b

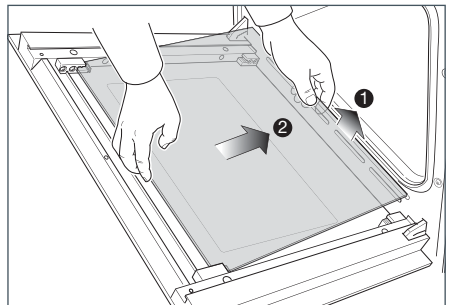

Fig.45c

Replacing the middle and inner panes of glass

- 1 Make sure the door is locked open (see Figs. 44a - 44c).
- 2 Replace the middle pane:
 - Check that the four rubber pads are in place ("M" in Fig. 46a).
 - Check that you are holding the pane the correct way. You should be able to read the wording on it as it faces you.
 - Gently insert the top edge of the pane into the top clamps (arrow 1 in Fig. 46b), then lower the pane and insert the bottom edge into the bottom clamps (arrow 2 in Fig. 46b); and then slide the pane into position (Fig. 46c).

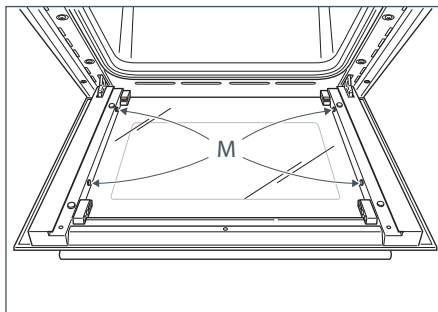

Fig.46a

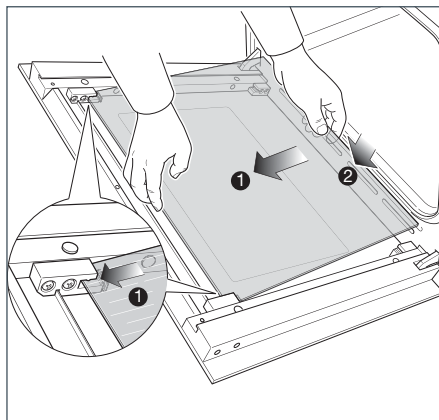

Fig.46b

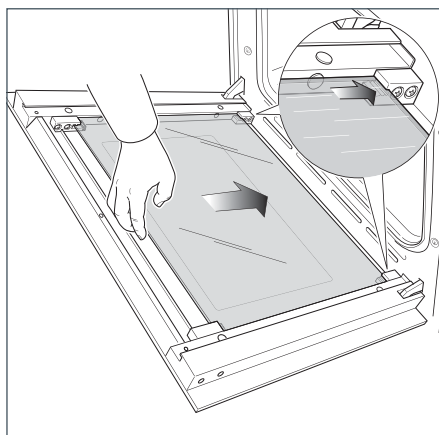

Fig.46c

- 3 Replace the inner pane:
 - Check that the four rubber pads are in place ("D" in Fig. 47a).
 - Check that you are holding the pane the correct way. You should be able to read the wording on it as it faces you.
 - Insert the pane in the left "E" and right "F" slide guides, and gently slide it to the retainers "H" (Fig. 47c).
 - Replace the seal "G" by hooking in the three fixing hooks. Make sure that you put it in the correct way (Fig. 47e).

- 4 Unlock the oven door by opening it completely and closing the lever "A" on the left and right hinges (Fig. 47d).

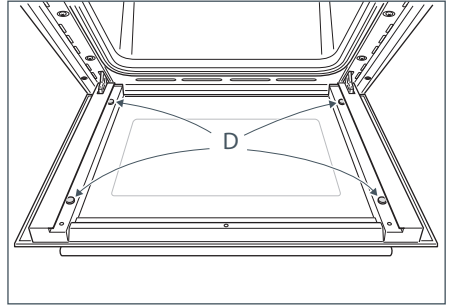

Fig.47a

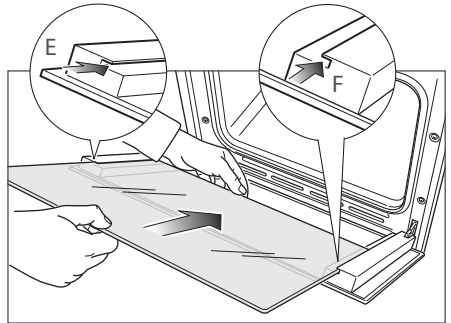

Fig.47b

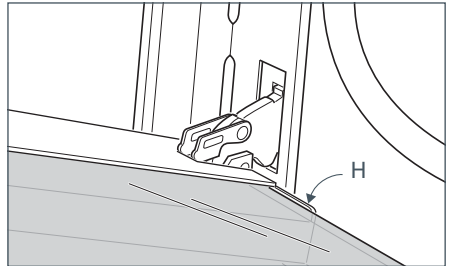

Fig.47c

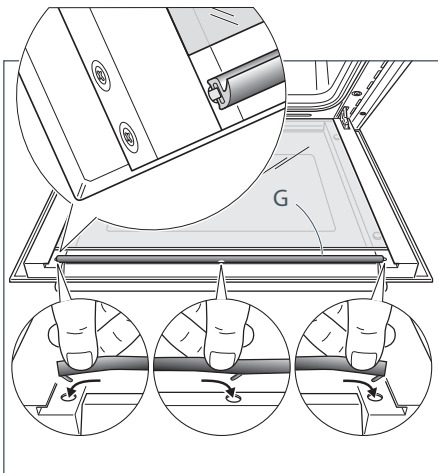

Fig.47e

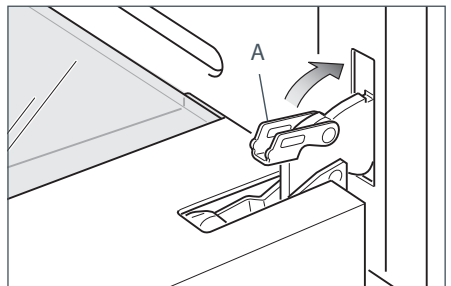

Fig.47d

Removing the oven door(s)

The oven door(s) can easily be removed as follows:

- 1 Open the door to its full extent (Fig. 48a).
- 2 Open the lever "A" completely on the left and right hinges (Fig. 48b).
- 3 Hold the door (Fig. 48c).
- 4 Gently close the door until left and right hinge levers "A" are hooked to part "B" of the door (Fig. 48d).
- 5 Withdraw the hinge hooks from their location following arrow "C" (Fig. 48e).
- 6 Rest the door on a soft surface.

To replace the door, repeat the above steps in reverse order.

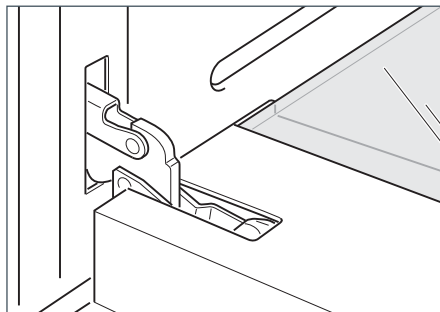

Fig.48a

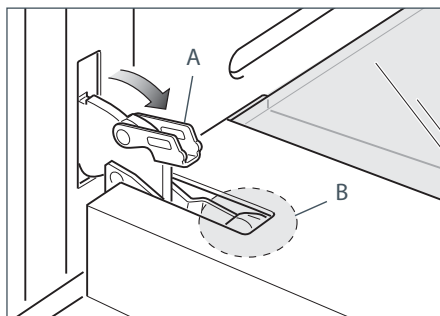

Fig.48b

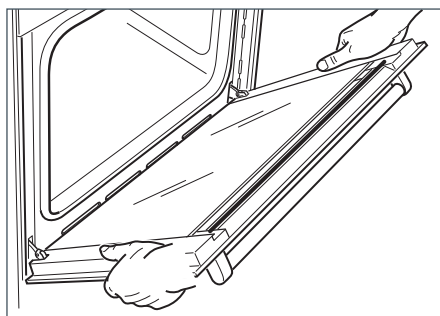

Fig.48c

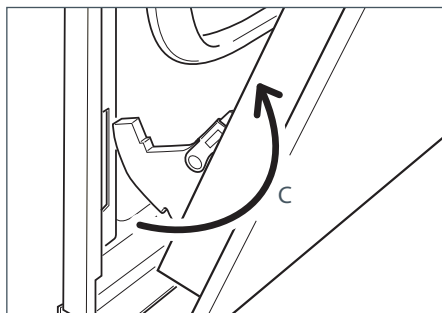

Fig.48e

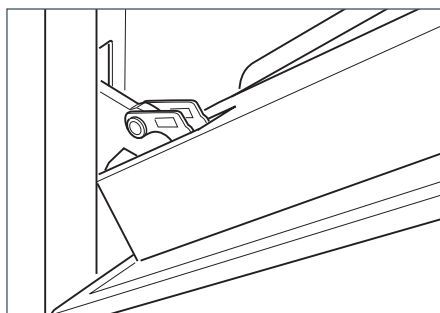

Fig.48d

Removing the drawers

- 1 Open the drawer completely (Fig. 49a).
- 2 To disengage the drawer from the guide rails, press the lever of the left guide rail down and pull the lever of the right guide rail up.
- 3 Remove the drawer, while still holding the levers.

Important!

Warning drawer (left drawer only):

- *Do not remove drawer while hot or during operation.*
- *Be sure drawer is empty before removing.*

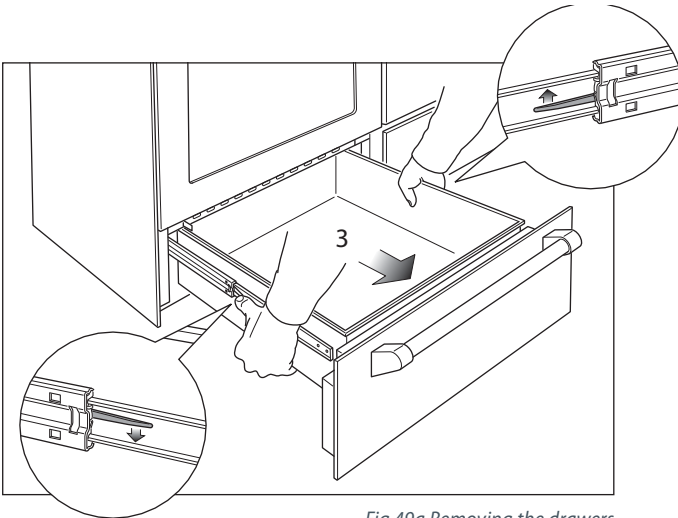

Fig.49a Removing the drawers

Replacing the drawers

- 1 Insert the drawer guides into the guide rails (Fig. 49b).
 - 2 Gently close the drawer completely; the safety catches will automatically hook.
- Note: make sure you put the drawers back on the correct side. The left (warmer) drawer is uncoated stainless steel.

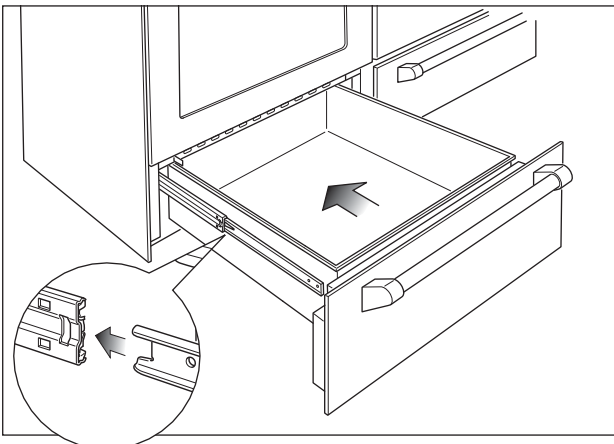

Fig.49b Replacing the drawers

Replacing the oven lamp

- 1 Switch the power to the cooker off at the wall.
- 2 Let the oven cavity and the heating elements cool down.
- 3 Remove the protective cover "C".
- 4 Unscrew and replace the bulb "B" with a new one suitable for high temperatures (300°C), with the following specifications: 230-240V, 50Hz, E14 and same wattage as the bulb being replaced (check wattage stamped on the bulb).
- 5 Refit the protective cover "C".

Note: oven bulb replacement is not covered by your warranty.

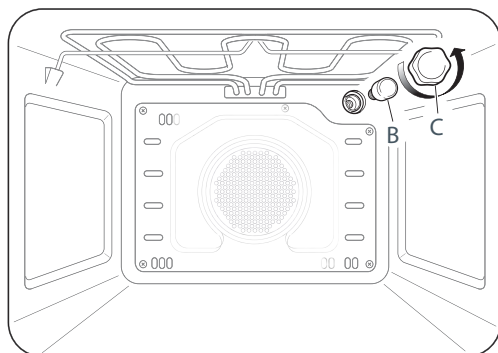

Fig.50 Removing the oven lamp

Before you call for service or assistance ...

Check the things you can do yourself. Refer to the installation instructions and your user guide and check that:

- 1 Your product is correctly installed.
- 2 You are familiar with its normal operation.

If after checking these points you still need assistance, please refer to the Service & Warranty book for warranty details and your nearest Authorised Service Centre, or contact us through our website:

www.fisherpaykel.com

This cooker has been designed and constructed in accordance with the following codes and specifications:

In New Zealand and Australia:

AGA101 (AS 4551) Approval Requirements for Domestic Gas cooking appliances

AS/NZS 60335-1 General Requirements for Domestic electrical appliances

AS/NZS 60335-2-6 Particular Requirements for Domestic electrical cooking appliances

AS/NZS 1044 Electromagnetic Compatibility Requirements.

www.fisherpaykel.co.nz
www.fisherpaykel.com.au

Fisher & Paykel

Copyright © Fisher & Paykel 2012. All rights reserved.

The product specifications in this booklet apply to the specific products and models described at the date of issue. Under our policy of continuous product improvement, these specifications may change at any time. You should therefore check with your Dealer to ensure this booklet correctly describes the product currently available.

Free Manuals Download Website

<http://myh66.com>

<http://usermanuals.us>

<http://www.somanuals.com>

<http://www.4manuals.cc>

<http://www.manual-lib.com>

<http://www.404manual.com>

<http://www.luxmanual.com>

<http://aubethermostatmanual.com>

Golf course search by state

<http://golfingnear.com>

Email search by domain

<http://emailbydomain.com>

Auto manuals search

<http://auto.somanuals.com>

TV manuals search

<http://tv.somanuals.com>