

# VOLKSWAGEN® NEW BEETLE

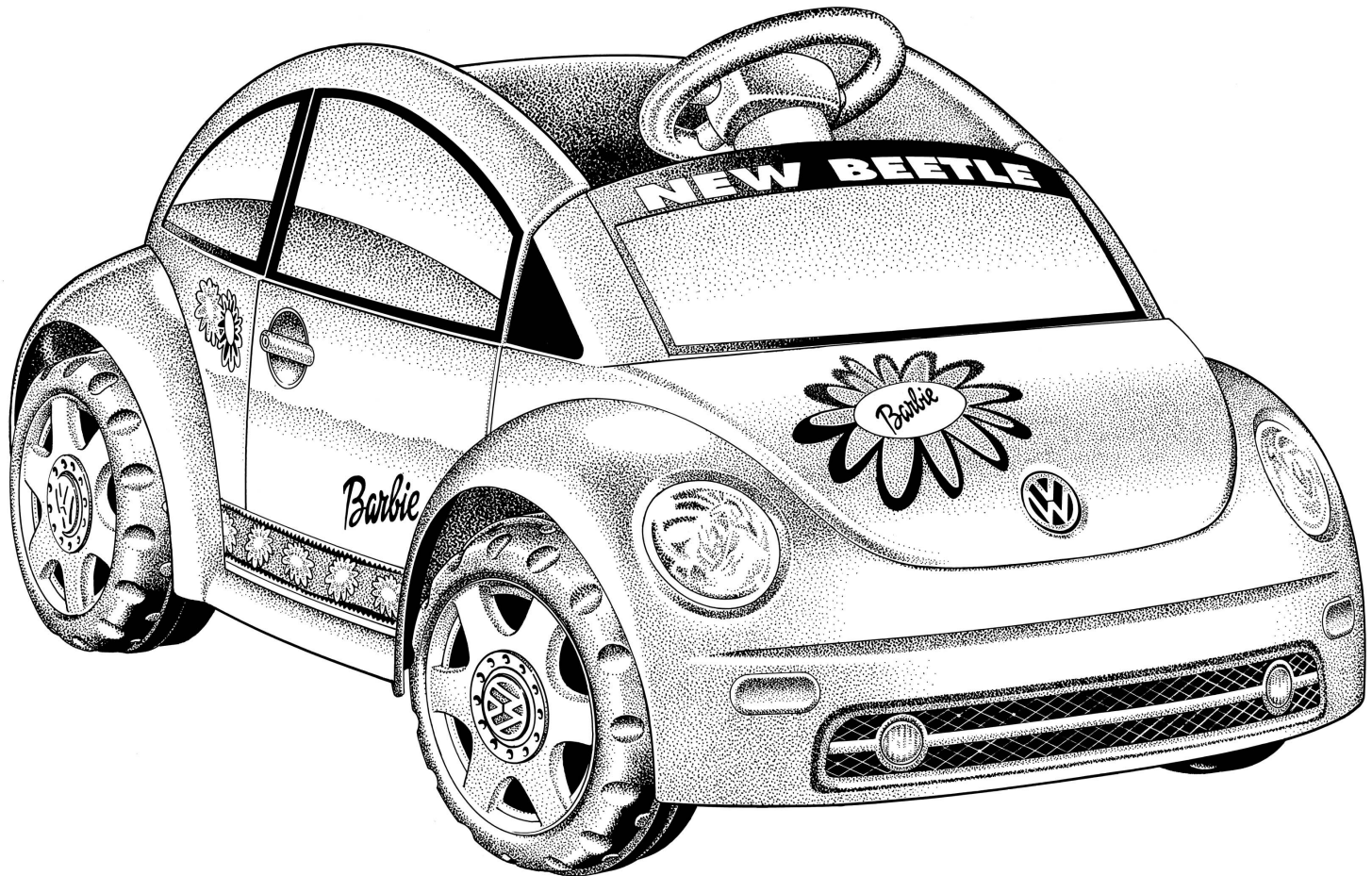

Product features and decoration may vary from the picture above.

**Please read this manual and save it with your original sales receipt.**

Tools needed for assembly: Phillips Screwdriver, Hammer, Slotted Screwdriver,  
Adjustable Wrench and Safety Scissors (tools not included).

Use only with a Power Wheels® Type H 6 Volt Battery, Power Wheels® 25 Amp Fuse and Power Wheels®  
Type H 6 Volt Charger (all included).

Trademarks, design patents and copyrights are used with  
the approval of the owner VOLKSWAGEN AG.  
Fisher-Price, Power Wheels, Power Wheels by Fisher-Price  
and Power Lock are U.S. trademarks of Mattel, Inc.

[www.powerwheels.com](http://www.powerwheels.com)



## Owner's Manual with Assembly Instructions

For Model C3491

## Table of Contents

<b>A</b>	Important Information .....	2
<b>B</b>	Warnings and Cautions .....	3
<b>C</b>	Parts .....	4
<b>D</b>	Parts Diagram .....	7
<b>E</b>	Battery Charging .....	8
<b>F</b>	Assembly .....	11
<b>G</b>	Label Decoration .....	22
<b>H</b>	Battery Installation .....	24
<b>I</b>	Battery Care and Disposal .....	26
<b>J</b>	Caring For Your Vehicle .....	26
<b>K</b>	Rules For Safe Driving .....	27
<b>L</b>	How to Operate Your Vehicle .....	28
<b>M</b>	Statement of Limited Warranty .....	28
<b>N</b>	Problems and Solutions Guide .....	29

# A

## Important Information

- Your new vehicle requires adult assembly. Please set aside at least 45 minutes for assembly.
- You must charge your battery for 18 - 30 hours **before you use your vehicle for the first time**. We recommend that you start charging your battery before beginning assembly. Please see Battery Charging beginning on page 8 for detailed instructions.
- Read this manual carefully for important safety information and operating instructions before using your vehicle. Keep these instructions for future reference as they contain important information.
- Use this vehicle **ONLY** outdoors. Most interior flooring can be damaged by riding this vehicle indoors. Fisher-Price® will not be responsible for damage to floors if the vehicle is used indoors.
- This vehicle is designed for use on: asphalt and other hard surfaces; on generally level terrain; and by children 1 1/2 - 4 years of age.
- Make sure children know and follow these rules for safe driving and riding:
  - always sit on the seat.
  - always wear shoes.
  - only 1 (one) rider at a time.
- To prevent damaging the motors and gears, do not tow anything behind the vehicle or overload it. Do not exceed the maximum weight capacity of 50 lbs (23 kg).
- If you have any questions about your Power Wheels® vehicle, please call our toll-free service lines at **1-800-348-0751** from 8 AM to 6 PM (EST) Monday through Friday. Trained customer service representatives are available to take your call in English or French. Habla Español? Si usted tiene alguna pregunta ó necesita asistencia llame gratis **1-800-348-0755** para los Estados Unidos. Tenemos representantes que hablan español para atender su llamada.
- For your convenience, Power Wheels® maintains an Authorized Service Center Network with more than 400 authorized service centers nationwide. Our authorized service centers will repair or replace parts under warranty at no extra charge, and can perform non-warranty repairs for a minimal charge. For the authorized service center nearest you, please visit us on-line at **www.powerwheels.com** or call **1-800-348-0751**.
- If you would like to register your vehicle, please visit us on-line at **www.powerwheels.com**.

**B****Warnings and Cautions****ELECTRICAL HAZARD** **WARNING**

- Battery can fall out and injure a child if vehicle tips over. Always use battery clamp.
- **PREVENT FIRE**
  - Do not bypass a Power Wheels® fuse. It is a safety device.
  - Use only a Power Wheels® 25 Amp fuse.
  - Never modify the electrical system. Alterations could cause a fire resulting in serious injury and could also ruin the electrical system.
  - Use of the wrong type battery or charger could cause a fire or explosion resulting in serious injury.
  - Use of Power Wheels® components in products other than Power Wheels® vehicles could cause overheating, fire or explosion.
- The battery must be handled by adults only. The battery is heavy and contains sulfuric acid (electrolyte). Dropping the battery could result in serious injury.
- Never allow children to charge the battery. Battery charging must be done by adults only. A child could be injured by the electricity involved in charging the battery.
- Never lift or carry the battery by the wires or connector. This can damage the battery and possibly cause a fire resulting in serious injury. Lift and carry the battery by the case only.
- Read the safety instructions on the battery.
- Examine the battery, charger and their connectors for excessive wear or damage each time you charge the battery. If damage or excessive wear is detected, do not use the charger or the battery until you have replaced the worn or damaged part.
- **HOT** motors. Handle carefully.

**RIDING HAZARD** **WARNING**

- **Prevent Injuries and Deaths**
  - Direct Adult Supervision Required
  - Keep Children Within Safe Riding Areas.  
These areas must be:
    - away from swimming pools and other bodies of water to prevent drownings
    - generally level to prevent tipovers
    - away from steps, driveways, cars, roads and alleys.

 **CAUTION**

- In the unassembled state, this package contains small parts. Adult assembly is required.
- Use the charger in dry locations only.

# C Parts

- If you experience a problem with this product, or are missing a part, please call us at **1-800-348-0751**, rather than return this product to the store.
- Please identify all parts before assembly and save all packaging material until assembly is complete to ensure that no parts are discarded.
- Metal parts have been coated with a lubricant to protect them during shipment. Wipe all metal parts with a paper towel to remove any excess lubricant.

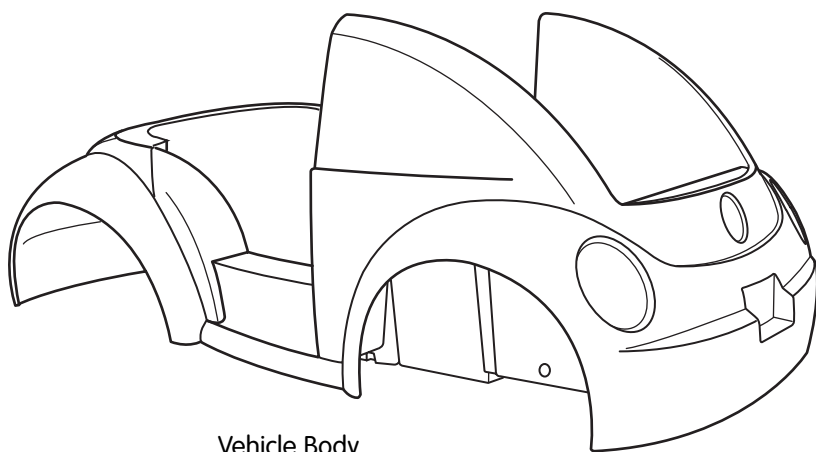

Vehicle Body

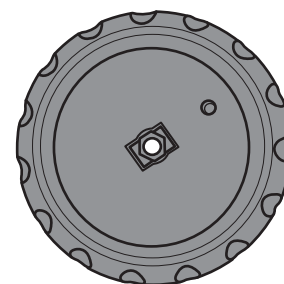

Wheel - 4

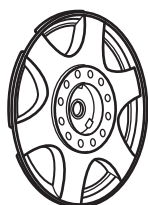

Hubcap - 4

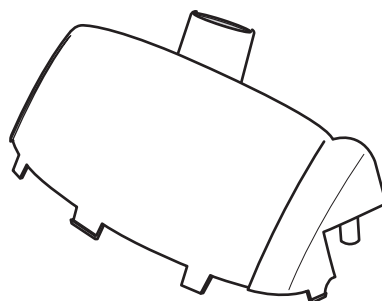

Windshield  
(Taped under vehicle body.)

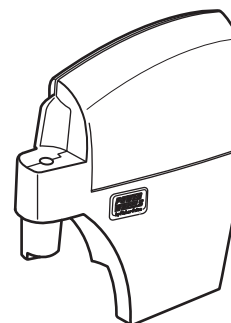

Door



Windshield Hinge

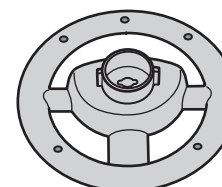

Steering Wheel Bottom

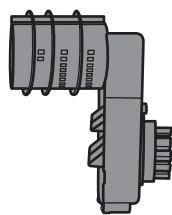

Gearbox

**Note:** The gearbox is temporarily fastened to the inside of the battery compartment. Refer to step 1 in the Assembly section, page 11.

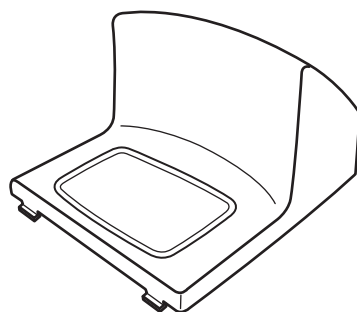

Seat

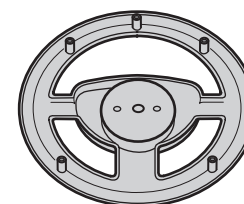

Steering Wheel Top

# Parts

**\*Note:** For your convenience, an extra 25 amp fuse is included.



Rear Axle

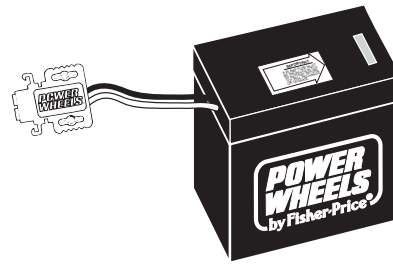

6 Volt Battery  
(Located in cardboard box  
inside battery compartment.)



Steering Column

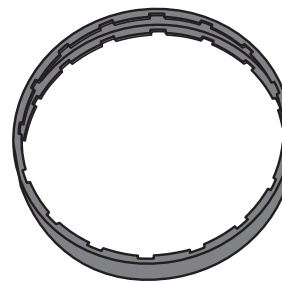

Front Wheel  
Traction Band - 2

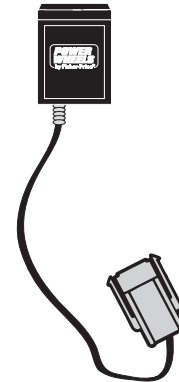

6 Volt Charger  
(Located in cardboard box  
inside battery compartment.)

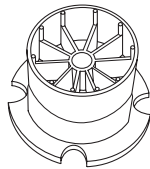

Driver



25 Amp Fuse - 1\*



Steering Linkage Cover  
(Taped under vehicle body.)



Hubcap Cover - 4



Steering Wheel  
Cap

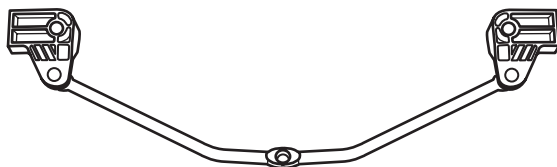

Steering Linkage



Rectangular Bushing - 2



Spacer



Hex Bushing - 2



Round Bushing - 6

**Not Shown:** Label Sheet - 2

## Parts

**\*Note:** For your convenience, an extra .437 white cap nut, .354 black cap nut and lock washer are included.

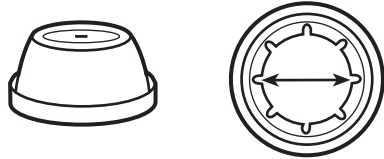

.437 (Large) White Cap Nut - 2\*

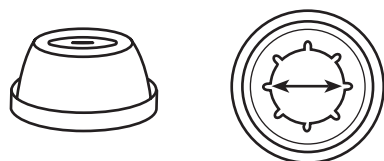

.354 (Small) Black Cap Nut - 2\*

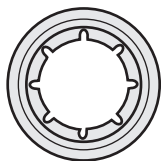

Lock Washer - 4\*

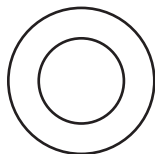

7/16" Large Washer - 5

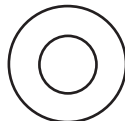

Small Washer - 2



#6 x 1/2" Screw - 5



#6 x 1" Screw - 2



1/4" x 1 1/4" Screw - 2



#8 x 3/4" Screw - 13  
(Small Diameter Head)



#10 x 3/4" Trusshead Screw  
(Large Diameter Head)



#10 Lock Nut

**Note: Tighten and loosen all screws with a Phillips Screwdriver. Do not over-tighten the screws.**

**All Shown Actual Size**

# D

## Parts Diagram

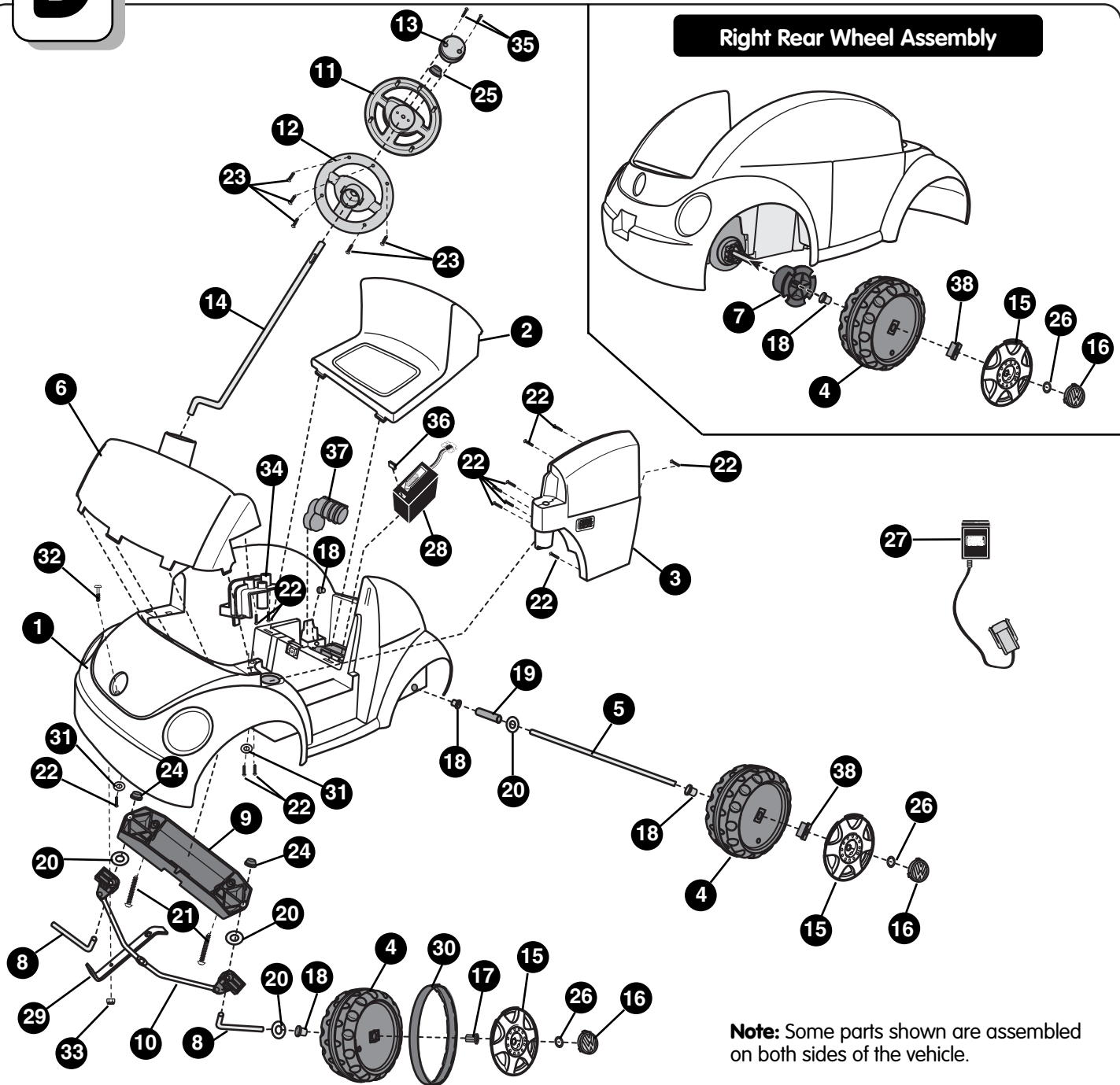

**Note:** Some parts shown are assembled on both sides of the vehicle.

- |                           |                             |                                    |
|---------------------------|-----------------------------|------------------------------------|
| 1. Vehicle Body           | 15. Hubcap - 4              | 27. 6 Volt Charger                 |
| 2. Seat                   | 16. Hubcap Cover - 4        | 28. 6 Volt Battery                 |
| 3. Door                   | 17. Hex Bushing - 2         | 29. Steering Bracket               |
| 4. Wheel - 4              | 18. Round Bushing - 6       | 30. Front Wheel Traction Band - 2  |
| 5. Rear Axle              | 19. Spacer                  | 31. Small Washer - 2               |
| 6. Windshield             | 20. Large Washer - 5        | 32. #10 x 3/4" Trusshead Screw     |
| 7. Driver                 | 21. 1/4" x 1 1/4" Screw - 2 | 33. #10 Lock Nut                   |
| 8. Front Axle - 2         | 22. #8 x 3/4" Screw - 13    | 34. Windshield Hinge               |
| 9. Steering Linkage Cover | 23. #6 x 1/2" Screw - 5     | 35. #6 x 1" Screw - 2              |
| 10. Steering Linkage      | 24. .437 White Cap Nut - 2  | 36. 25 Amp Fuse                    |
| 11. Steering Wheel Top    | 25. .354 Black Cap Nut      | 37. Gearbox                        |
| 12. Steering Wheel Bottom | 26. Lock Washer - 4         | 38. Rectangular Bushing - 2        |
| 13. Steering Wheel Cap    |                             | <b>Not Shown</b> - Label Sheet - 2 |
| 14. Steering Column       |                             |                                    |

## E

## Battery Charging

**ELECTRICAL HAZARD****⚠ WARNING**

- Battery can fall out and injure a child if vehicle tips over. Always use battery clamp.
- **PREVENT FIRE**
  - Do not bypass a Power Wheels® fuse. It is a safety device.
  - Use only a Power Wheels® 25 Amp fuse.
  - Never modify the electrical system. Alterations could cause a fire resulting in serious injury and could also ruin the electrical system.
  - Use of the wrong type battery or charger could cause a fire or explosion resulting in serious injury.
  - Use of Power Wheels® components in products other than Power Wheels® vehicles could cause overheating, fire or explosion.
- The battery must be handled by adults only. The battery is heavy and contains sulfuric acid (electrolyte). Dropping the battery could result in serious injury.
- Never allow children to charge the battery. Battery charging must be done by adults only. A child could be injured by the electricity involved in charging the battery.
- Never lift or carry the battery by the wires or connector. This can damage the battery and possibly cause a fire resulting in serious injury. Lift and carry the battery by the case only.
- Read the safety instructions on the battery.
- Examine the battery, charger and their connectors for excessive wear or damage each time you charge the battery. If damage or excessive wear is detected, do not use the charger or the battery until you have replaced the worn or damaged part.

**⚠ CAUTION**

Use the charger in dry locations only.

**Important Notes**

- **Your new battery must be charged for at least 18 hours before you use it in your vehicle for the first time.**
- We recommend that you start charging your battery before beginning assembly of your new vehicle.
- The battery must be upright while charging.
- The charger is not a toy.
- Do not short circuit the battery.
- You do not need to remove the battery from your vehicle to recharge it.
- Before charging the battery, examine the battery case for cracks or other damage which may allow sulfuric acid (electrolyte) to leak during the charging process. Never attempt to charge a damaged battery. If damage is detected, do not charge the battery or use it in your vehicle. Battery acid is very corrosive and can cause severe damage to surfaces it contacts. Take precautions to protect any surface on which you charge the battery.
- Do not charge the battery on a surface (such as kitchen countertops) which could be damaged by the acid contained inside the battery. Take precautions to protect the surface on which you charge your battery.
- Use only a Power Wheels® Type H 6 volt charger (120 VAC 60 Hz 12W with an output of 6 VDC 4.8W [800 mA]) to charge your Power Wheels® 6 volt battery.
- If your battery is old and will not accept a charge, do not leave it in the vehicle. Always remove a dead battery from the vehicle.



## Battery Charging

**IMPORTANT!** The battery must be removed from your vehicle for the initial charge in order to complete assembly. After assembly is complete, you do not need to remove the battery from your vehicle to recharge it.

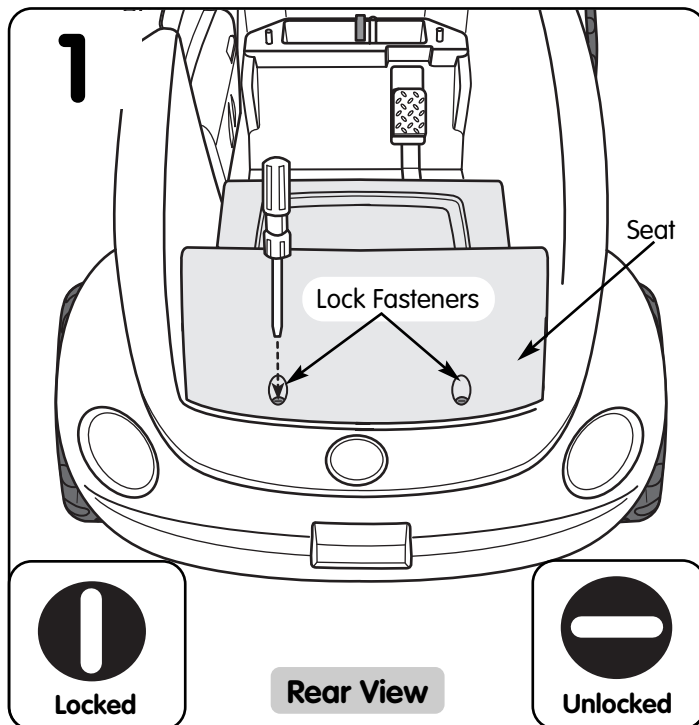

- Locate the lock fasteners in the back of the seat.
- Using a slotted screwdriver, turn each lock fastener  $\frac{1}{4}$  turn to the unlocked  position.

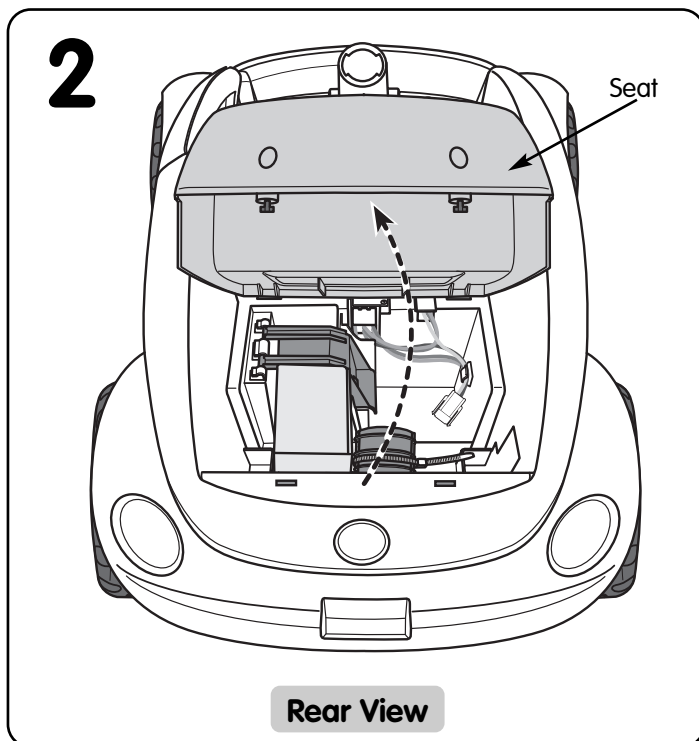

- Lift the seat to remove it from the vehicle body.

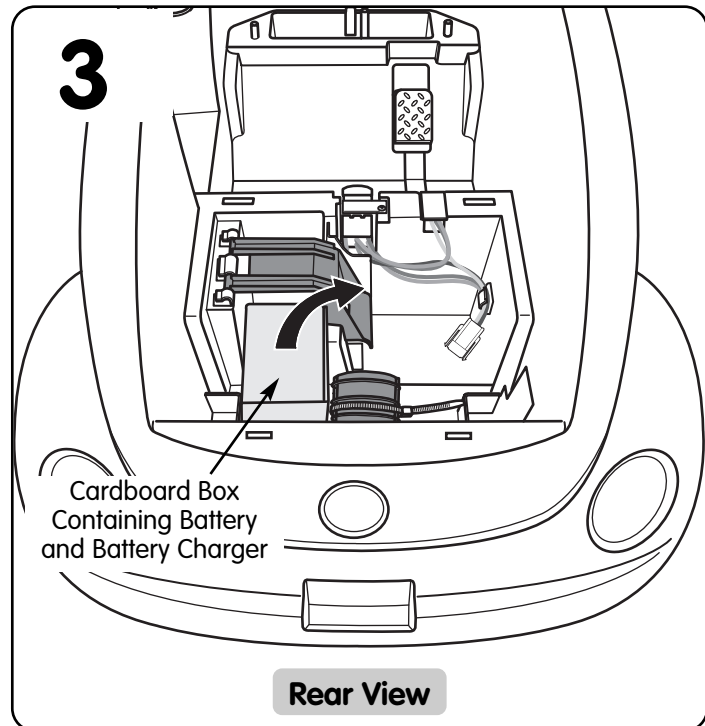

- Remove the cardboard box containing the battery and battery charger from the battery compartment.

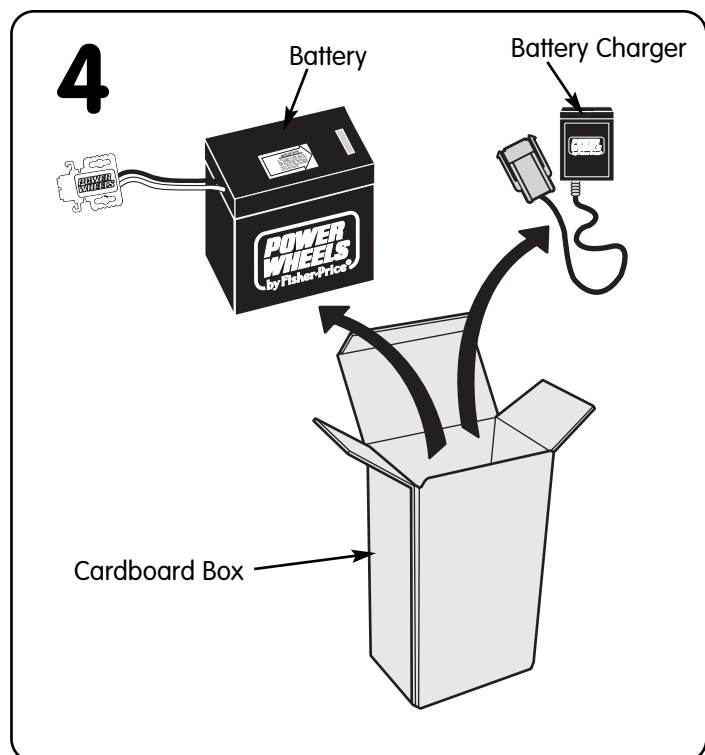

- Remove the battery and the battery charger from the cardboard box. Throw the cardboard box away.

## Battery Charging

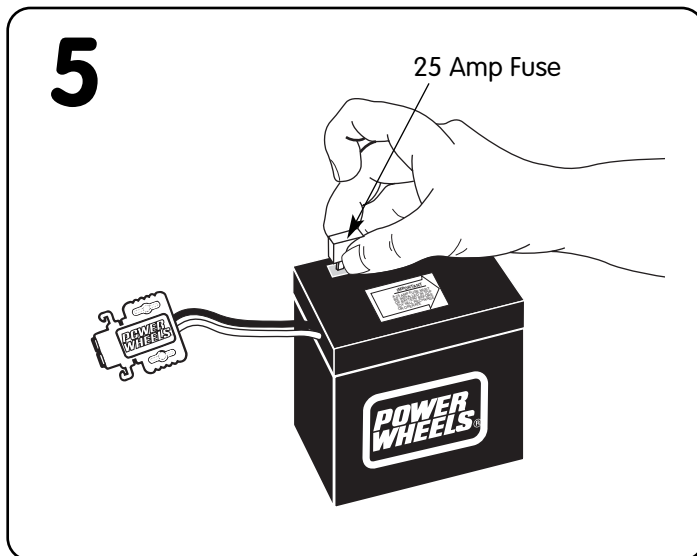

- Insert a Power Wheels® 25 amp fuse into the battery.

**Note:** The top of the fuse will not be flush with the top of the battery when properly installed.

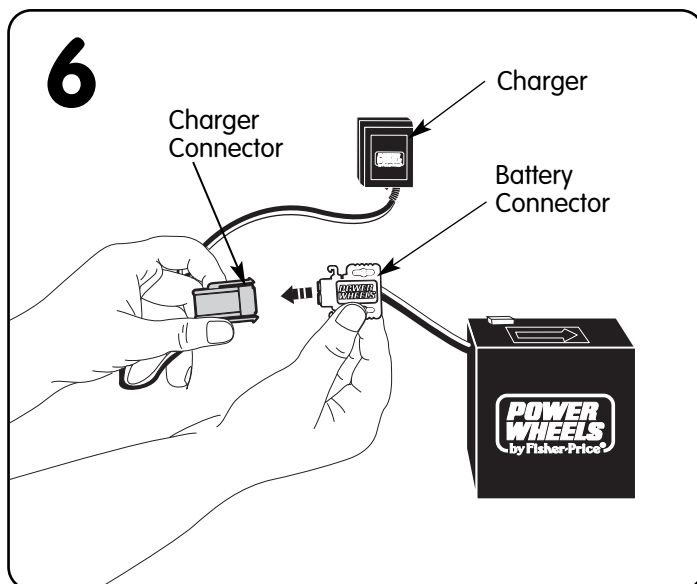

- Plug the battery connector into the charger connector.

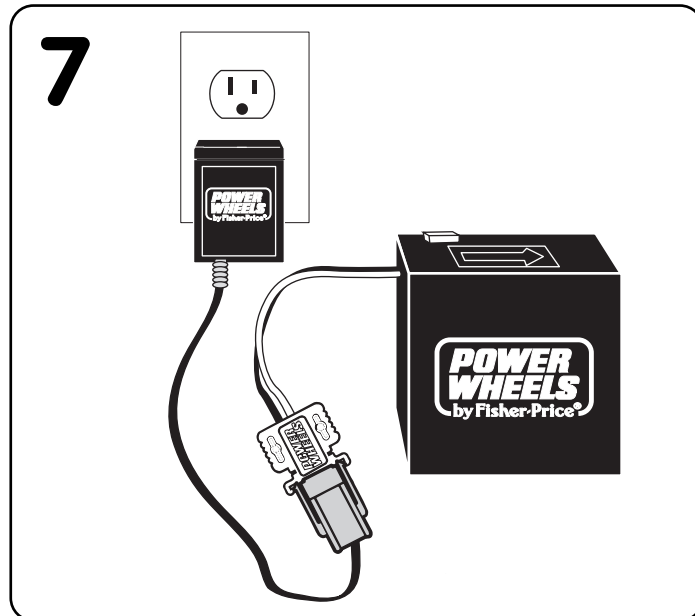

- Plug the charger into a standard 120 volt wall outlet.

**Note:** If power flow to the wall outlet is controlled by a switch, make sure the switch is ON.

- Before first time use, charge the battery for at least 18 hours. Never charge the battery longer than 30 hours.

**Note:** The battery must be upright while charging.

- Recharge the battery after each use of your vehicle for at least 14 hours. Do not charge the battery longer than 30 hours.

- Once the battery is charged, disconnect the charger connector from the battery connector. Unplug the charger from the wall outlet. The battery is now ready to be installed in your vehicle. Please see "Battery Installation" on page 24 for detailed instructions on installing your battery. If your battery is already installed in your vehicle, simply re-connect the battery connector and motor harness connector and re-assemble the seat.

# F

## Assembly

### ! WARNING

Children can be harmed by small parts, sharp edges and sharp points in the vehicle's unassembled state, or by electrical items. Care should be taken in unpacking and assembly of the vehicle. Children should not handle parts, including the battery, or help in assembly of the vehicle.

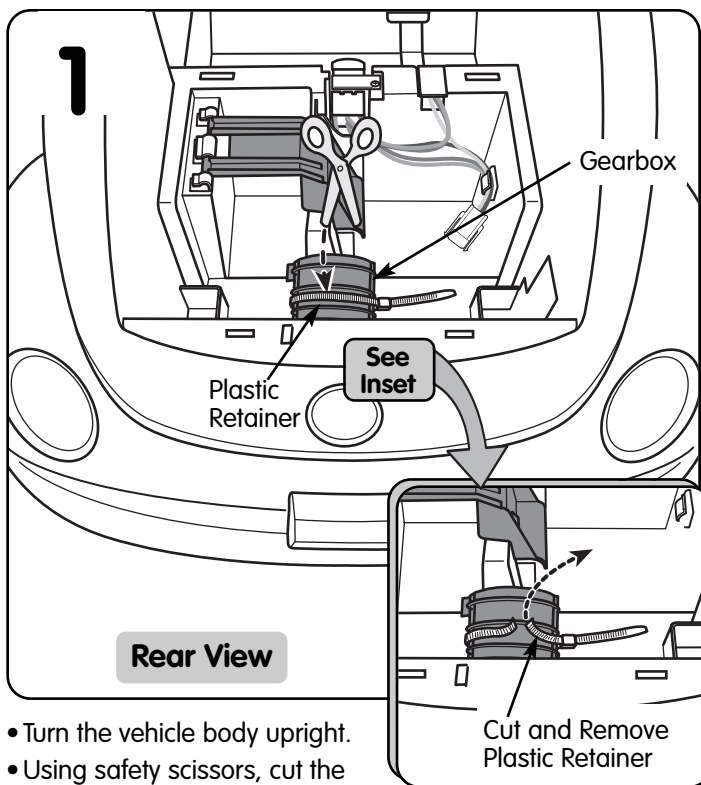

- Turn the vehicle body upright.
- Using safety scissors, cut the plastic retainer holding the gearbox in place.
- Throw the plastic retainer away.

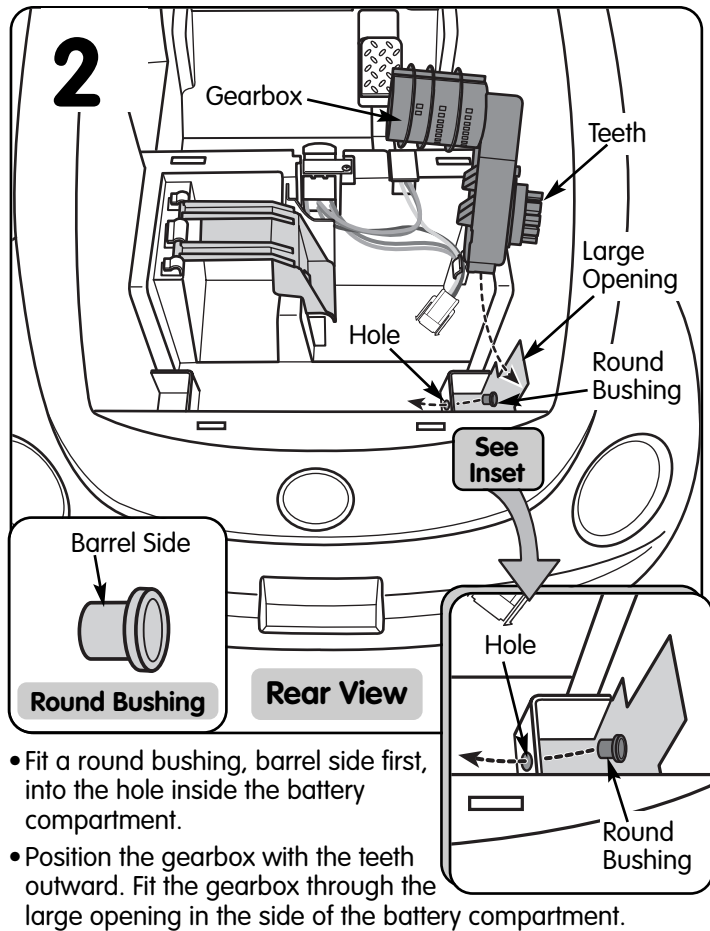

- Fit a round bushing, barrel side first, into the hole inside the battery compartment.
- Position the gearbox with the teeth outward. Fit the gearbox through the large opening in the side of the battery compartment.

## Assembly

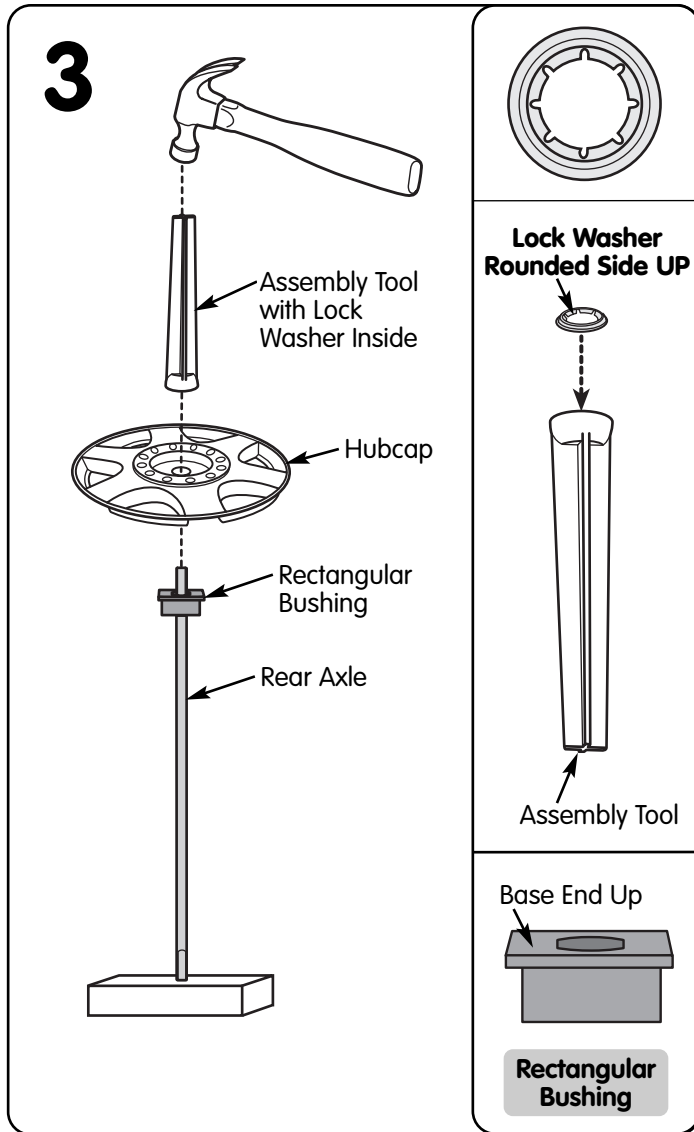

- With the base end up, fit a rectangular bushing onto the end of the rear axle.
  - Position a hubcap with the ridges down. Fit the hubcap onto the rear axle.
  - Fit a lock washer (rounded side up) into the assembly tool. Make sure it fits completely inside the assembly tool.
  - Position the rear axle with the hubcap up, as shown. Fit the assembly tool (with lock washer in it) onto one end of the rear axle.
  - Tap the assembly tool with a hammer to secure the lock washer on the end of the rear axle.
- Hint:** You may want to position the rear axle on a scrap block of wood to protect the assembly surface.
- Pull on the lock washer to be sure it is secure on the rear axle.

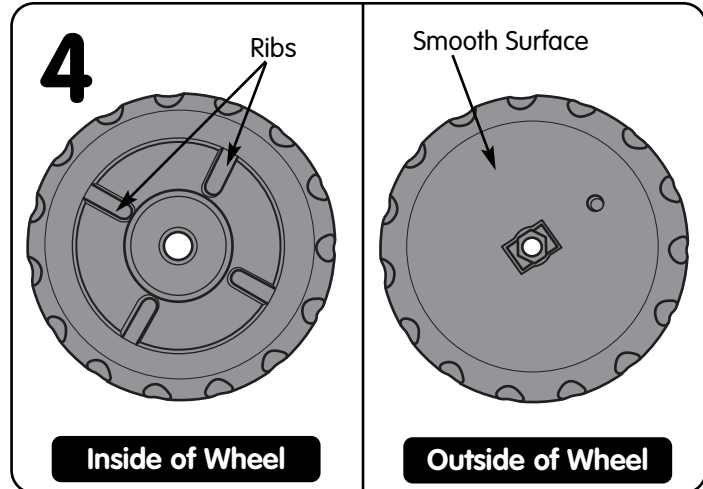

- Identify the inside and the outside of a wheel.
- The inside of the wheel has ribs on its surface. The outside of the wheel has a smooth surface.

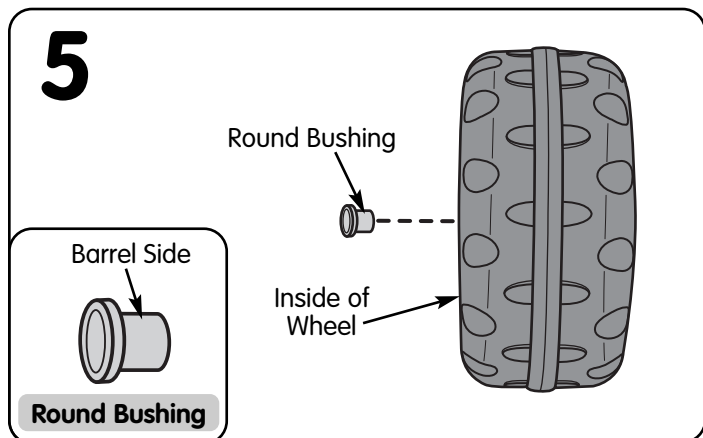

- Fit a round bushing, barrel side first, into the hole in the inside of a wheel (ribbed side).
- Repeat this procedure to insert a round bushing into the inside of another wheel.

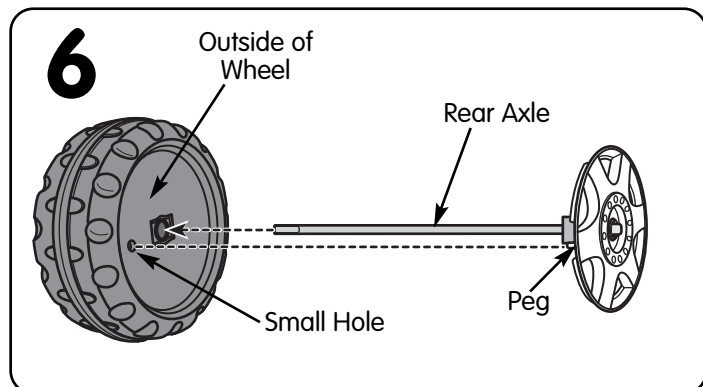

- Insert the rear axle into the hole in the outside (smooth side) of the wheel.
- Be sure to align the rectangular bushing with the rectangular opening in the outside of the wheel.
- Fit the peg on the inside of the hubcap into the small hole in the outside of the wheel.

## Assembly

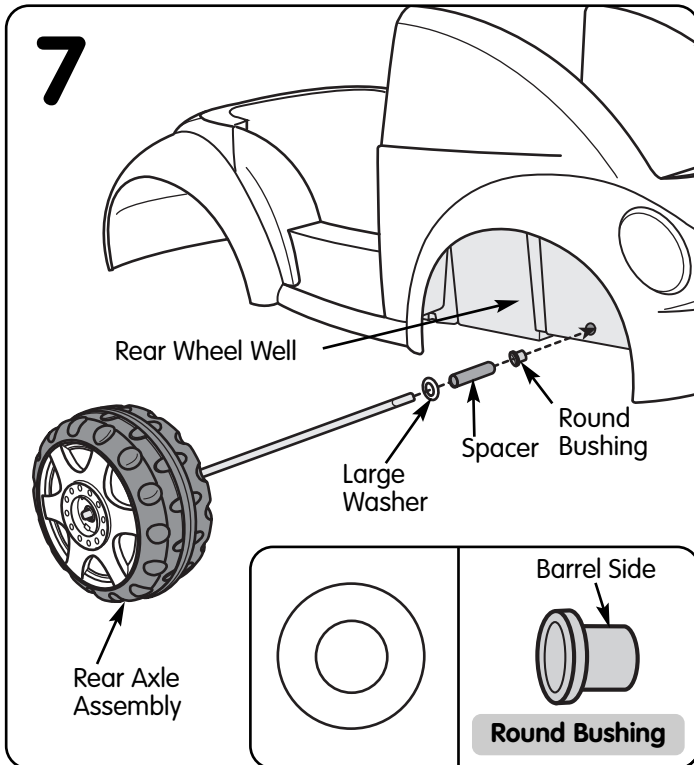

- Fit a round bushing, barrel side first, into the hole in the vehicle body rear wheel well, as shown.
- Slide a large washer onto the rear axle assembly.
- Slide a spacer onto the rear axle assembly.
- Fit the rear axle assembly through the round bushing and into the hole in the vehicle body rear wheel well.

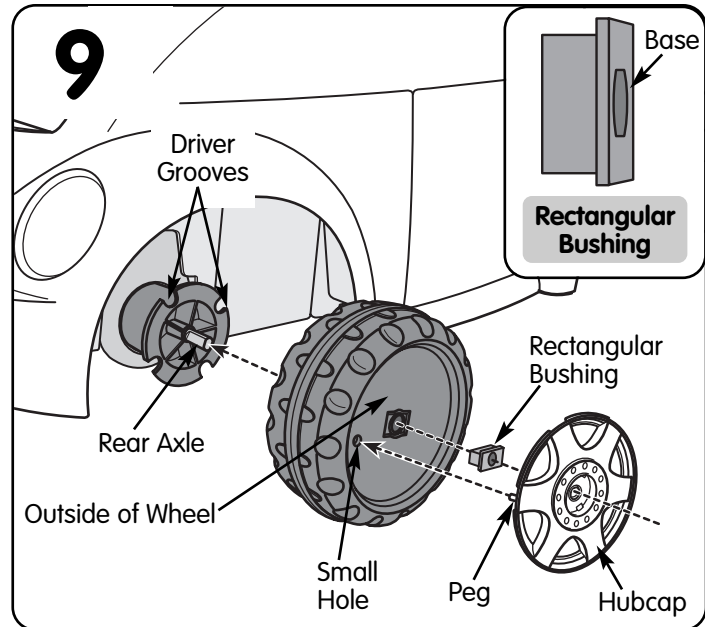

- Fit another wheel (with a round bushing inserted) onto the end of the rear axle. Make sure the outside of the wheel (smooth side) faces out and the ribs on the inside of the wheel fit in the grooves in the driver.
- Fit a rectangular bushing, base side out, onto the rear axle.
- Push the rectangular bushing so that it fits into the rectangular opening in the wheel.
- Fit a hubcap to the outside of the wheel. Make sure the peg on the hubcap fits into the small hole in the outside of the wheel.

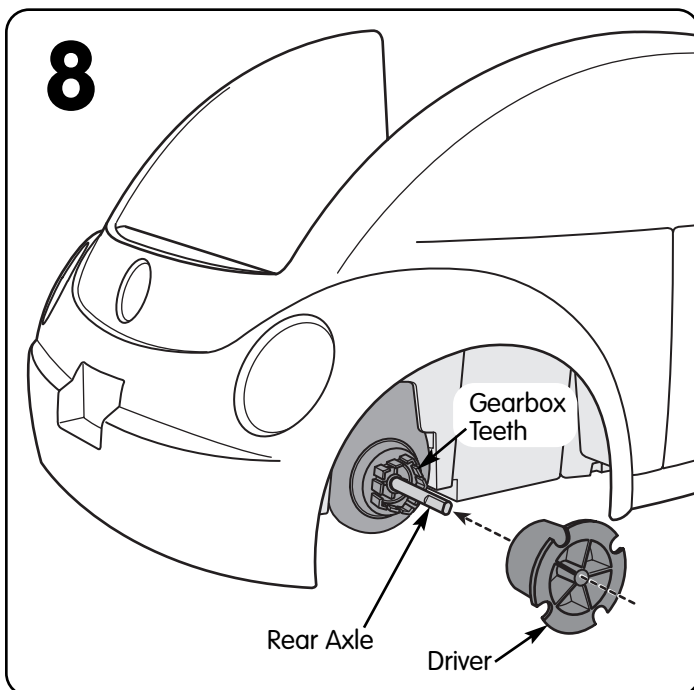

- Fit the driver onto the end of the rear axle.
- Align the ribs on the inside of the driver with the gearbox teeth. Fit the driver to the gearbox.

## Assembly

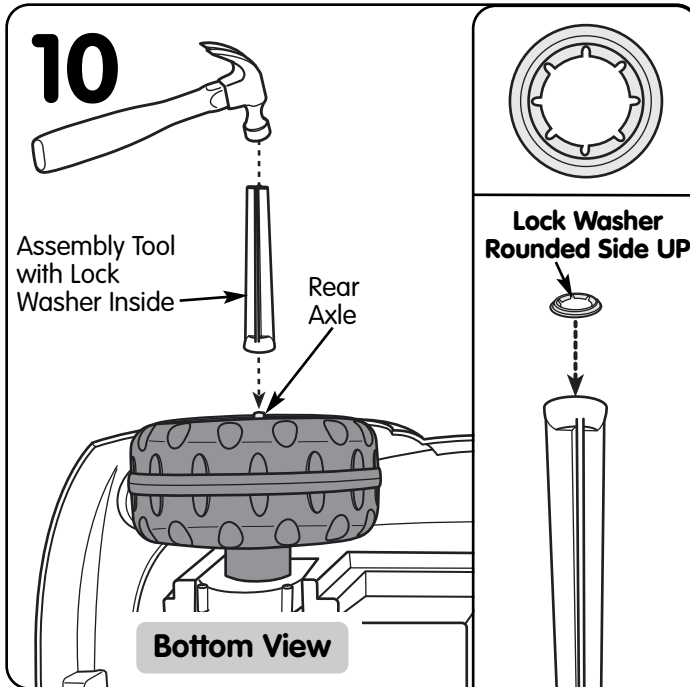

- Turn the vehicle body on its side.
- Fit a lock washer (rounded side up) into the assembly tool. Make sure it fits completely inside the assembly tool.
- Fit the assembly tool (with lock washer in it) onto the end of the rear axle.
- Tap the assembly tool with a hammer to secure the lock washer on the end of the rear axle.
- Pull on the lock washer to be sure it is secure on the rear axle.

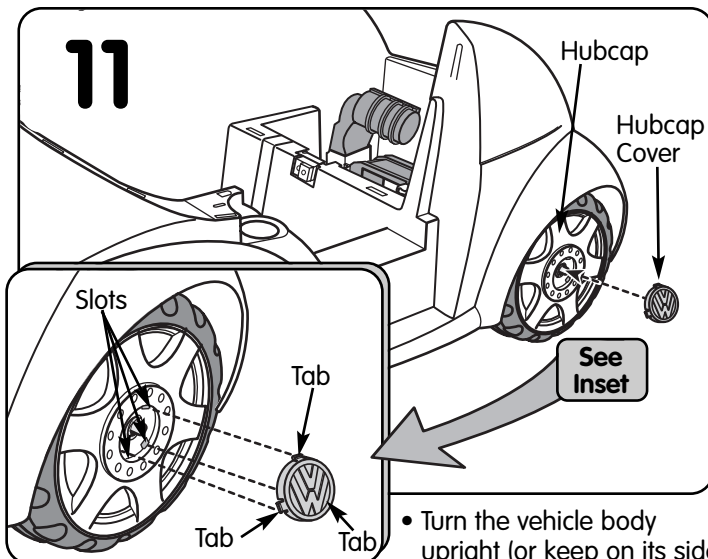

- Turn the vehicle body upright (or keep on its side).
- Insert one of the tabs on the hubcap cover into a slot in the hubcap.
- Then, push with your fingernail (or carefully with a slotted screwdriver), the other two hubcap cover tabs into the slots in the hubcap.
- Repeat this procedure to assemble another hubcap cover to the other hubcap.

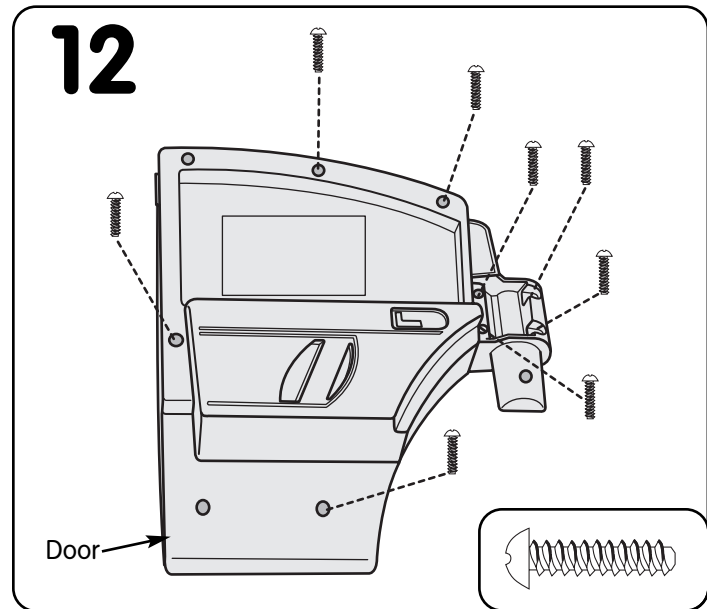

- Insert eight #8 x  $\frac{3}{4}$ " screws into the door, as shown. Tighten the screws.

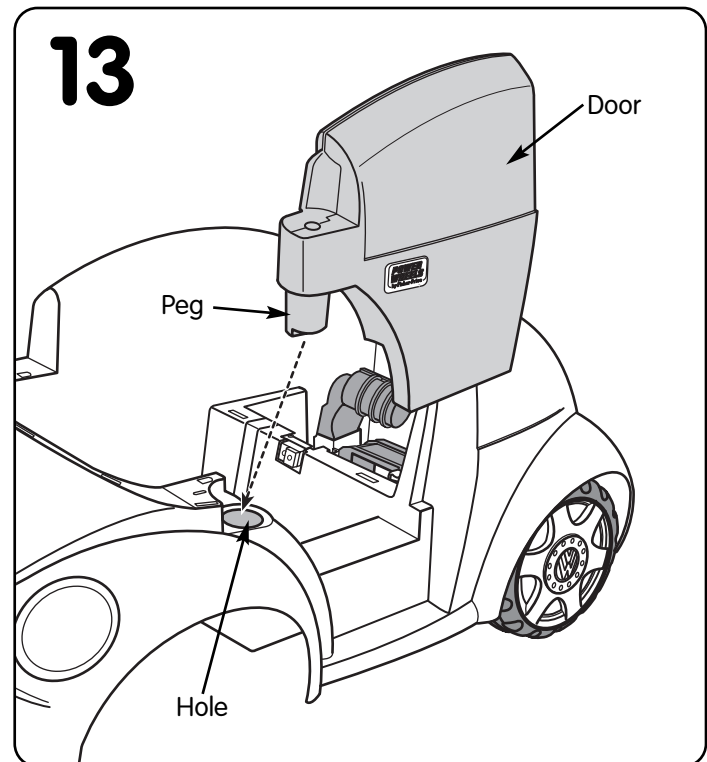

- Fit the door peg into the hole in the top of the vehicle body.

# 14

## Assembly

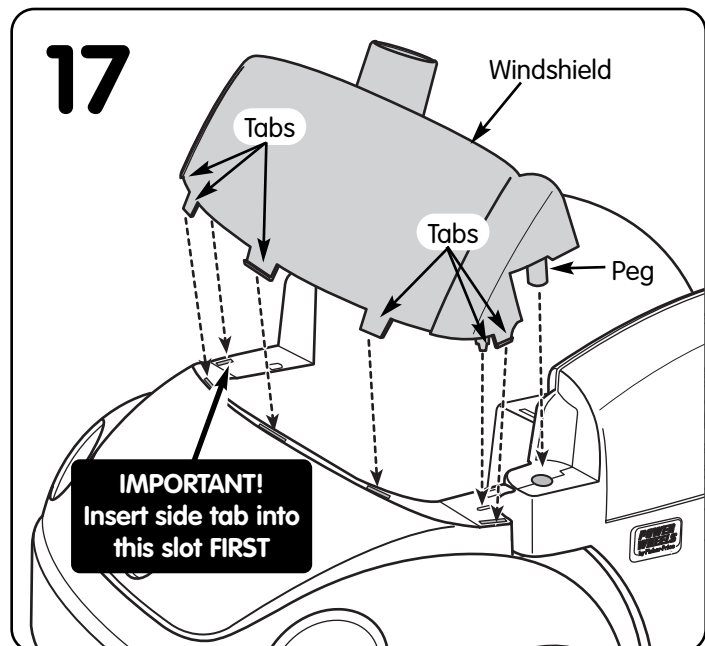
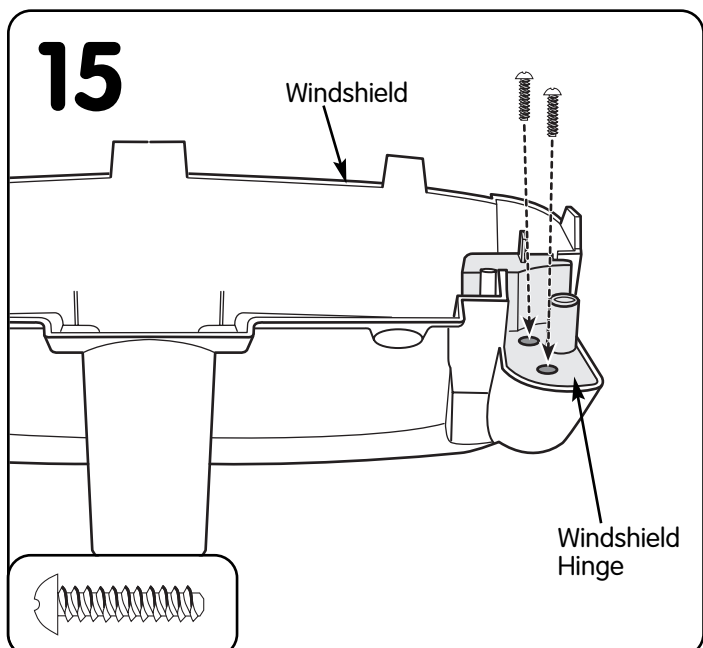
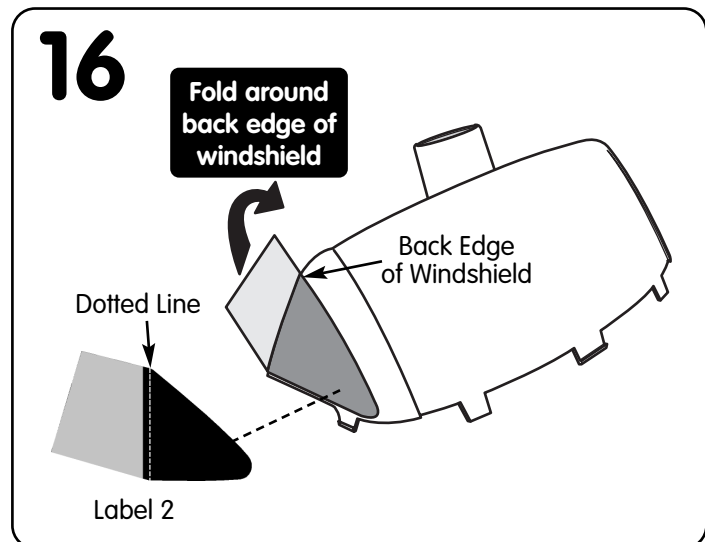
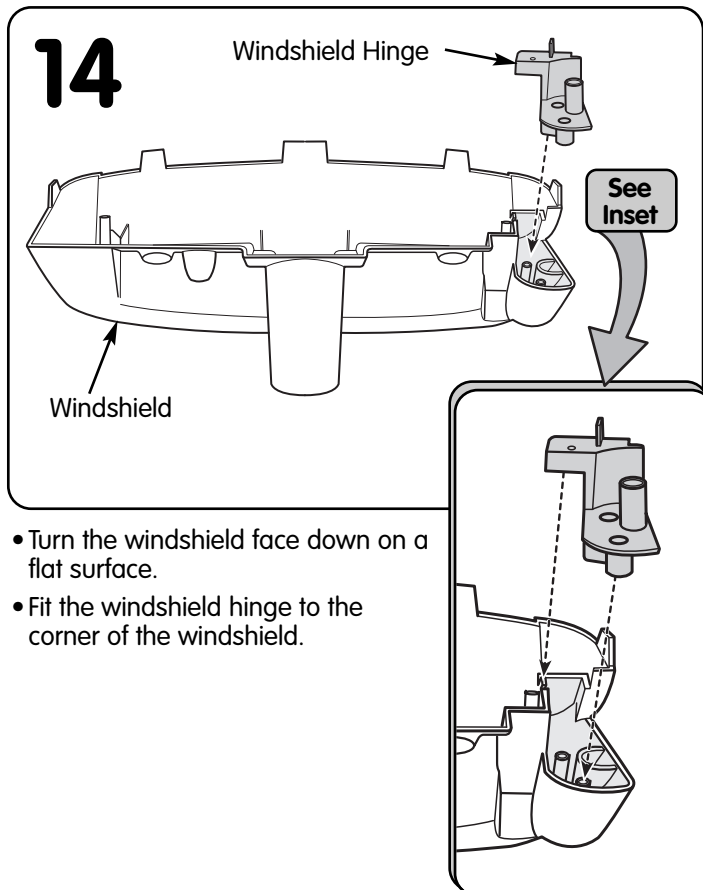

# Assembly

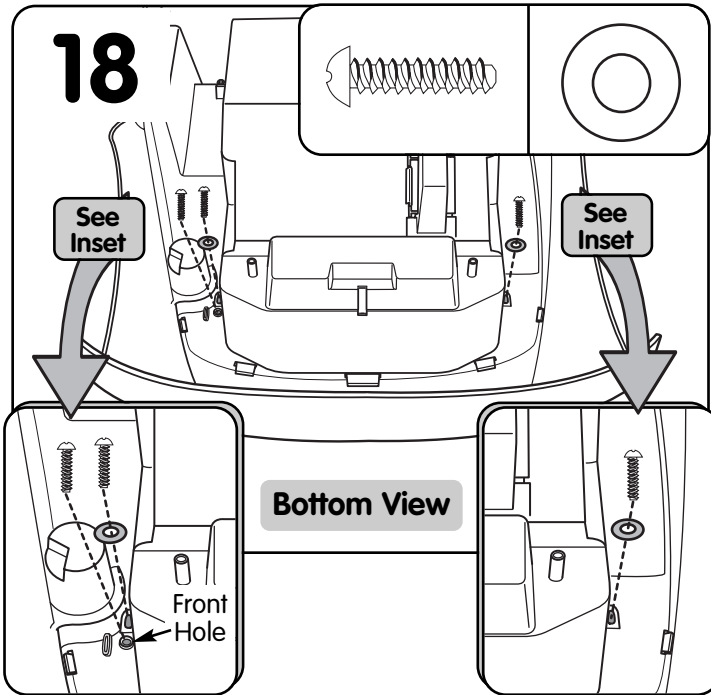

- Turn the vehicle body over so that the bottom faces you.
- Insert one #8 x 3/4" screw through the front hole in the vehicle body and into the windshield, as shown.
- Fit a small washer to two #8 x 3/4" screws. Insert these screws with washers through the other holes in the vehicle body and into the windshield, as shown.
- Tighten the screws.

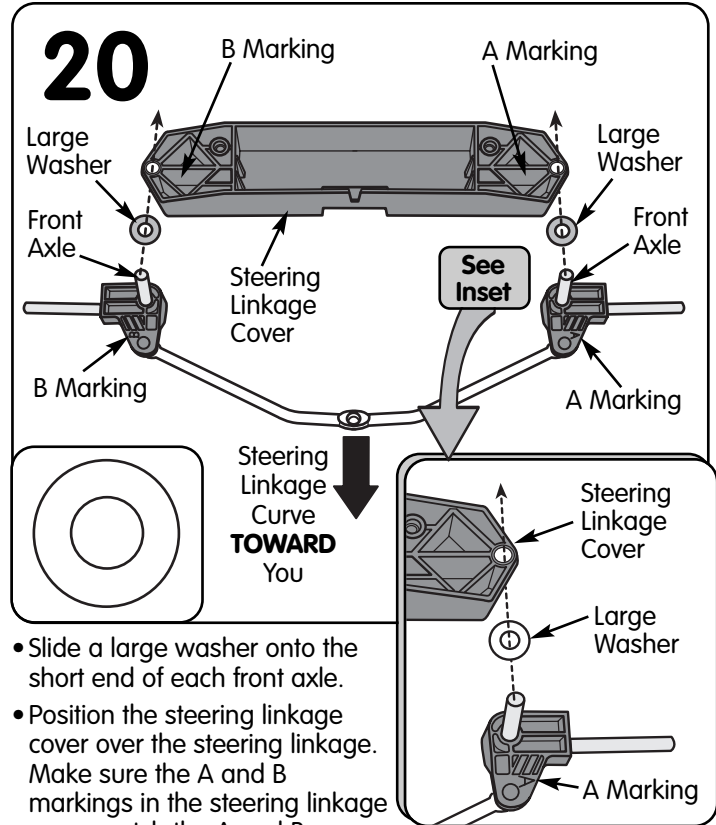

- Slide a large washer on the short end of each front axle.
- Position the steering linkage cover over the steering linkage. Make sure the A and B markings in the steering linkage cover match the A and B markings in the steering linkage. Fit the steering linkage cover onto the front axles.

**Note:** The steering linkage curve should still face you.

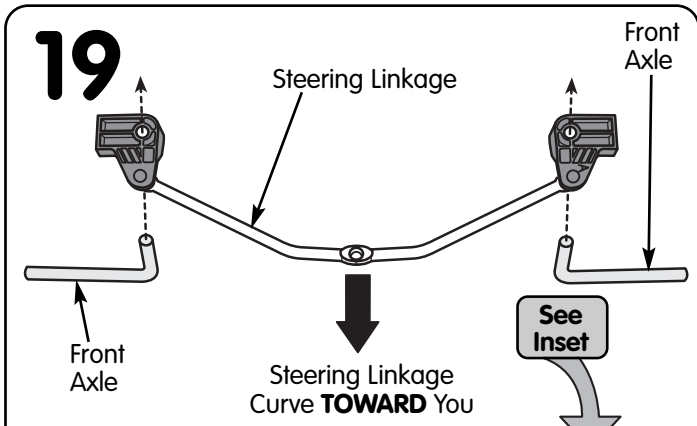

- Turn the steering linkage so that the inside (grooved side) is facing up and the curve is toward you.
- Position each front axle so that the short end is facing up.
- Insert the short end of the front axles up through the ends of the steering linkage, as shown.

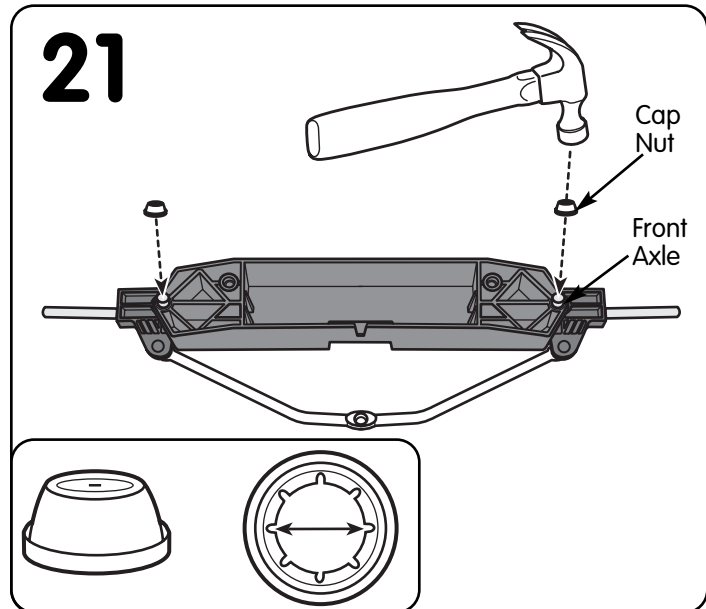

- Fit a .437 white cap nut onto the end of a front axle.
- Tap the cap nut with a hammer to secure it to the end of the front axle.
- Repeat this procedure to fasten another .437 white cap nut to the other front axle.



## Assembly

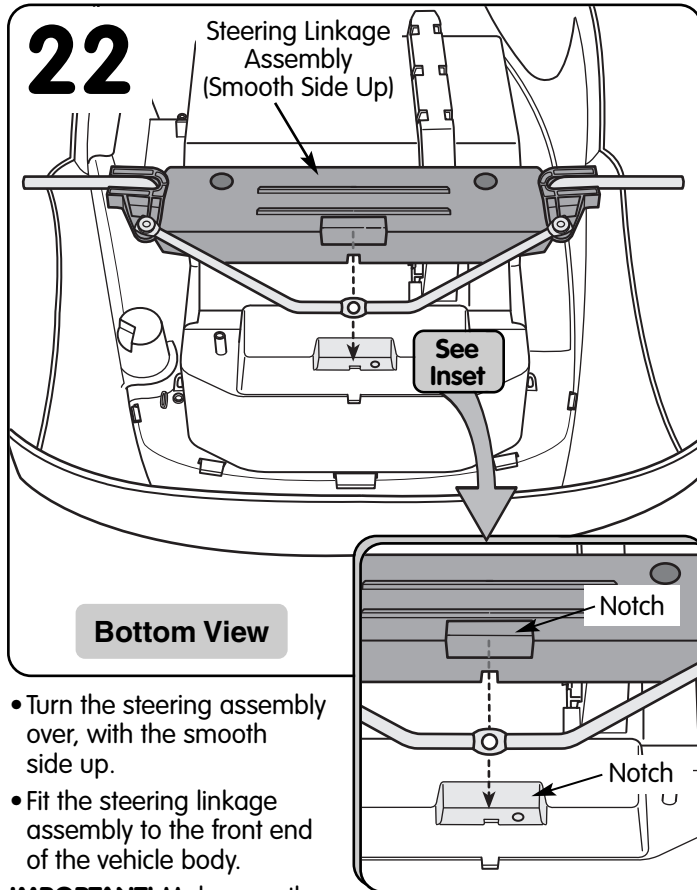

- Turn the steering assembly over, with the smooth side up.
- Fit the steering linkage assembly to the front end of the vehicle body.

**IMPORTANT!** Make sure the notch on the steering linkage assembly aligns with the notch in the front end of the vehicle body.

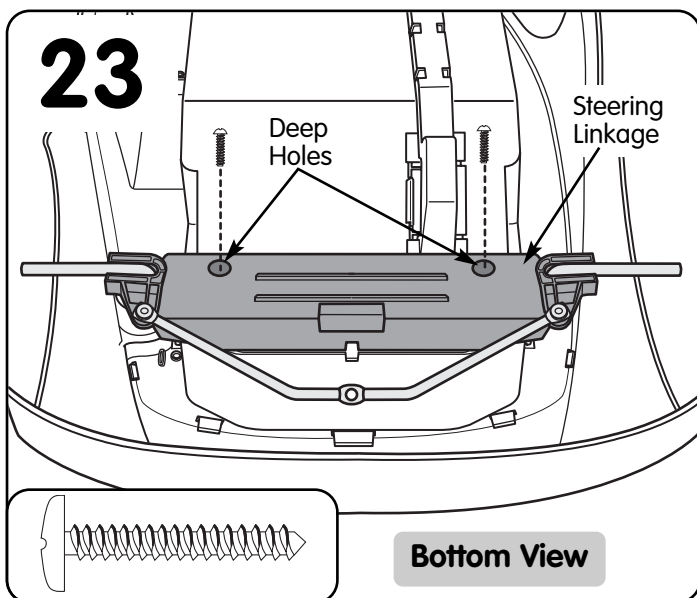

- Insert two  $\frac{1}{4}$ " x  $1\frac{1}{4}$ " screws through the deep holes in the steering linkage assembly and into the vehicle body.
- Tighten the screws with a Phillips screwdriver. Do not over-tighten.
- Pull up on the steering linkage assembly to be sure it is secure. If it is not secure, tighten the screw with a few more turns.

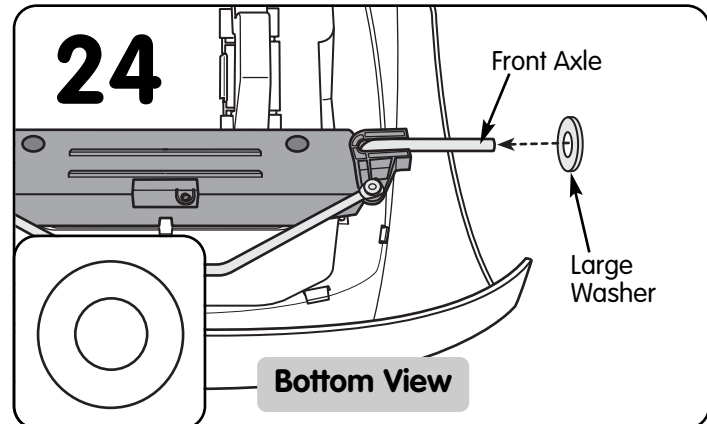

- Fit a large washer onto a front axle.

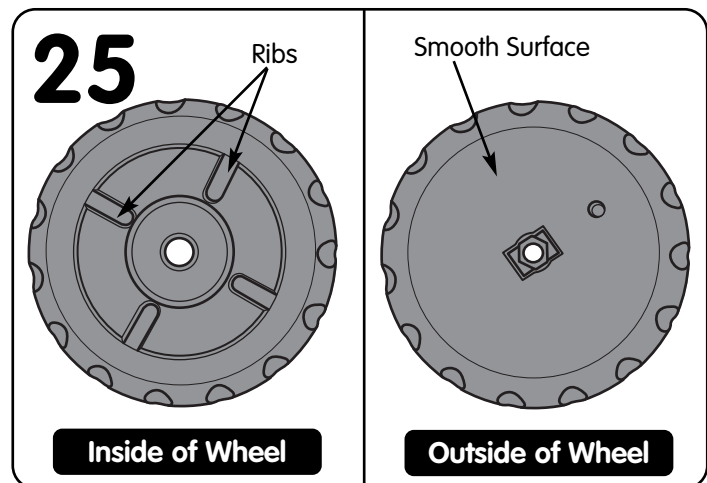

- Identify the inside and the outside of a wheel.
- The inside of the wheel has ribs on its surface. The outside of the wheel has a smooth surface.

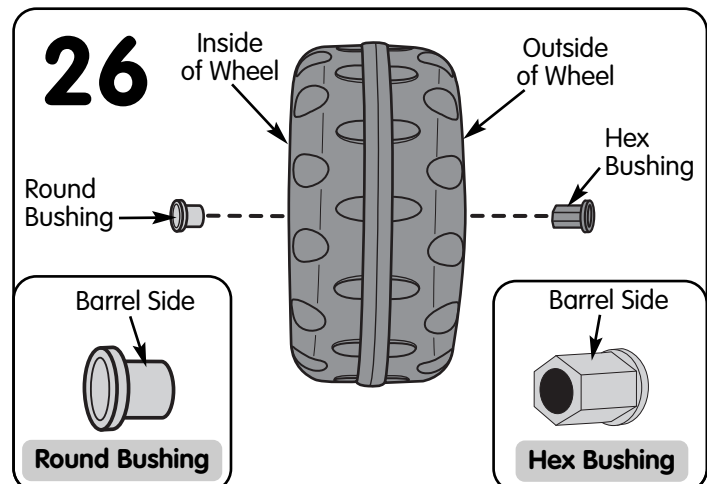

- Fit a round bushing, barrel side first, into the hole in the inside of a wheel (ribbed side).
- Fit a hex bushing, barrel side first, into the hole in the outside of a wheel (smooth side).
- Repeat this procedure to insert a round bushing and hex bushing into the remaining wheel.

## Assembly

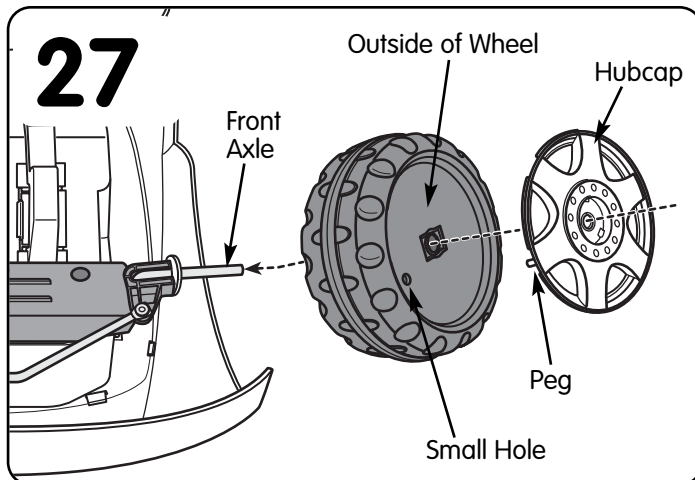

- Fit the wheel (with a round bushing and hex bushing inserted) onto the end of the front axle. Make sure the outside of the wheel (smooth side) faces out.
- Fit a hubcap to the outside of the wheel. Make sure the peg on the hubcap fits into the small hole in the outside of the wheel.

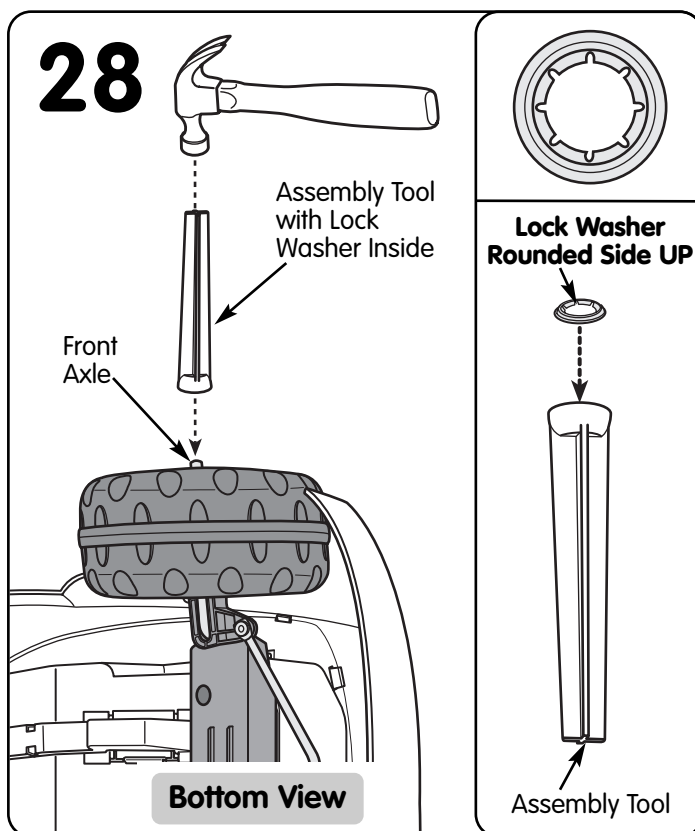

- Turn the vehicle body on its side.
- Fit the lock washer (rounded side up) into the assembly tool. Make sure it fits completely inside the assembly tool.
- Fit the assembly tool (with lock washer in it) onto the end of the front axle.
- Tap the assembly tool with a hammer to secure the lock washer on the end of the front axle.
- Pull the wheel up to be sure it is secure on the front axle.

**18**

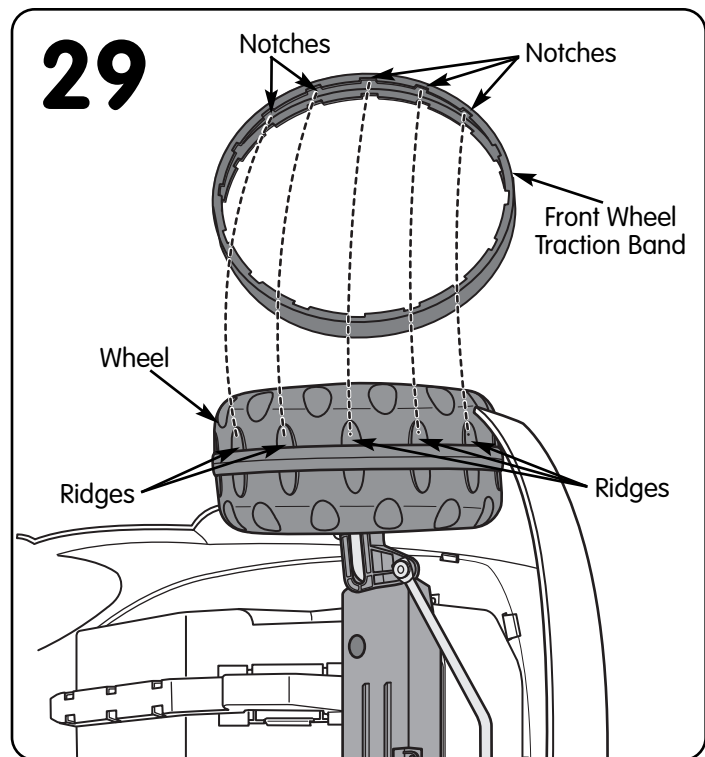

- Fit the notches on the inside of a front wheel traction band to the ridges on a front wheel, as shown.

**Hint:** You may want to soak the traction band in hot water for about two minutes to soften it.

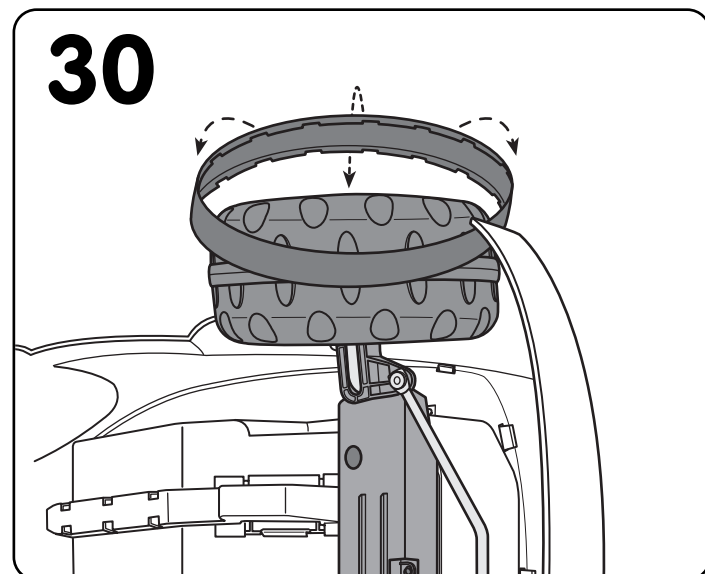

- Slide the other side of the front wheel traction band around the front wheel.

## Assembly

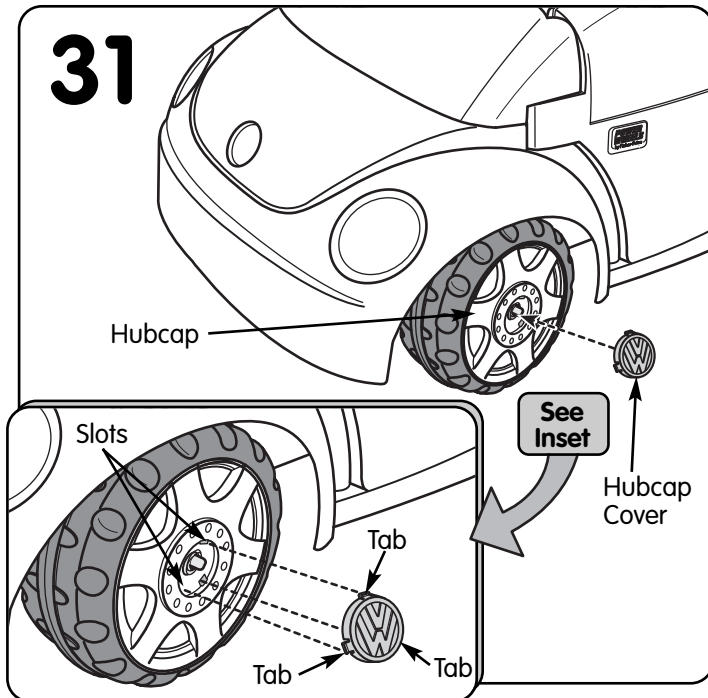

- Turn the vehicle body upright (or keep it on its side).
- Fit a hubcap cover into the hubcap.
- Insert one of the tabs on the hubcap cover into a slot in the hubcap.
- Then, push with your fingernail (or carefully with a slotted screwdriver), the other two hubcap cover tabs into the slots in the hubcap.
- Repeat assembly steps 27 - 31 to assemble the remaining wheel, round bushing, hex bushing, washer, lock washer, front wheel traction bands, hubcap and hubcap cover.

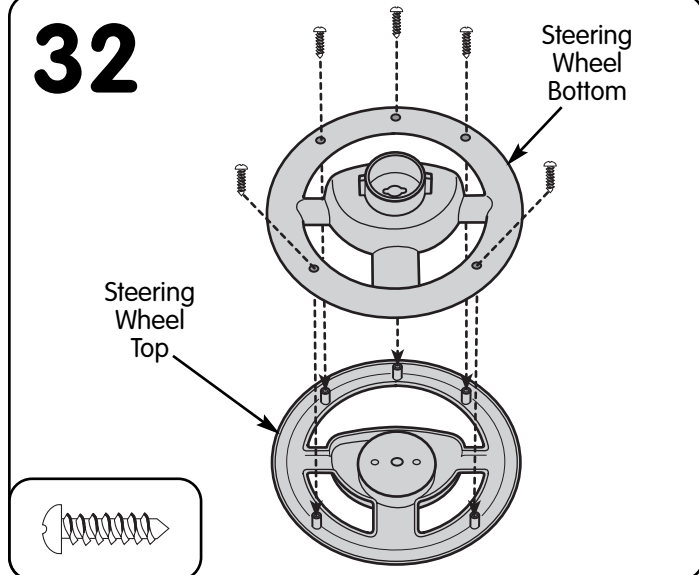

- Place the steering wheel top face down on a flat surface.
- Fit the steering wheel bottom to the steering wheel top.
- Insert five #6 x 1/2" screws through the steering wheel bottom and into the steering wheel top. Tighten the screws.

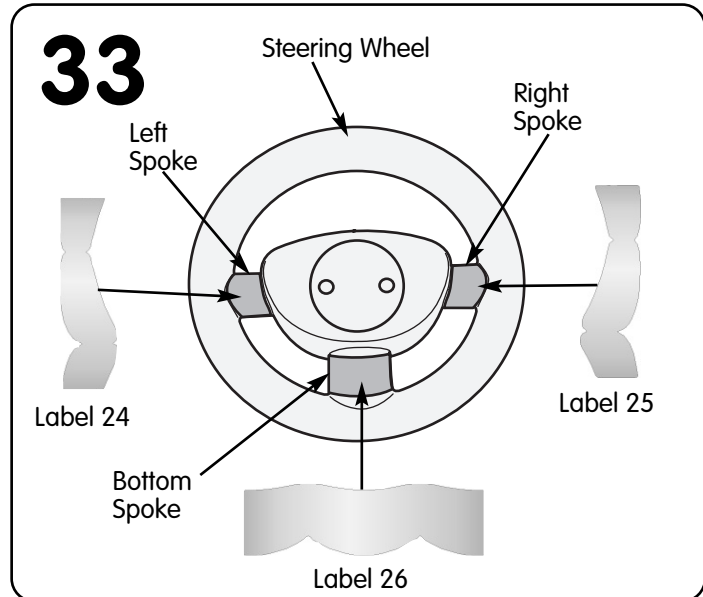

- Cut the steering wheel labels (#24, #25 and #26) from the smaller label sheet. Now, position the steering wheel labels, as shown in the illustration, around the steering wheel.

**Hint:** These labels will be applied around the spokes on the steering wheel. Carefully apply the center portion of each label to the topside of each spoke. Gently smooth the label around each spoke.

- Remove the backing from label 24 and apply the label to the left spoke. Throw the backing away.
- Remove the backing from label 25 and apply the label to the bottom spoke. Throw the backing away.
- Remove the backing from label 26 and apply the label to the right spoke. Throw the backing away.

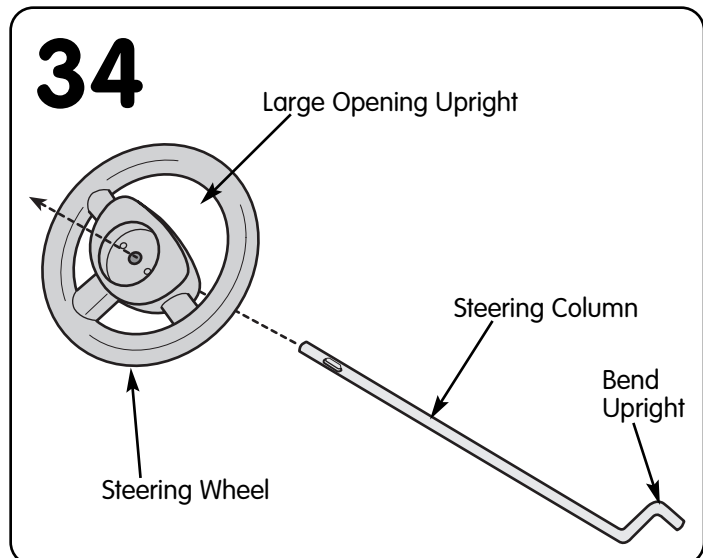

- Position the steering wheel with the large opening **upright**.
- Position the steering column so that the bend is **upright**, as shown.
- Fit the steering column through the center hole in the steering wheel.

## Assembly

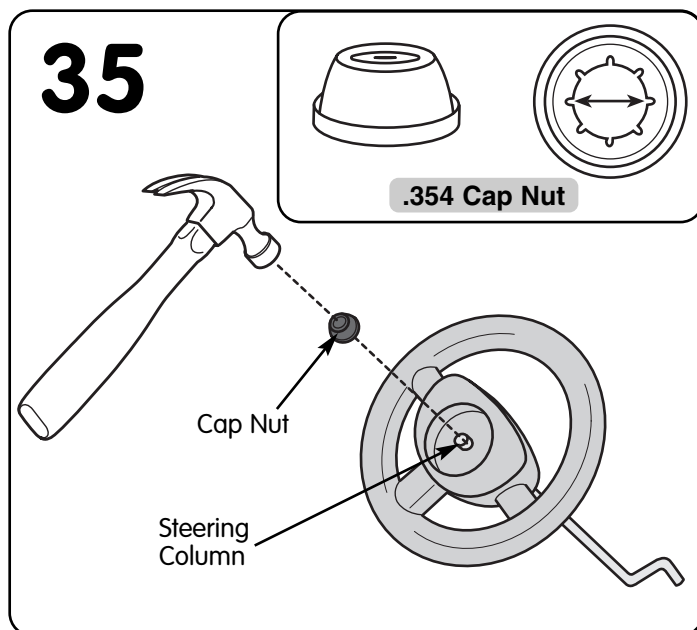

- Fit a .354 black cap nut onto the end of the steering column.
- Tap the cap nut with a hammer to secure it on the steering column.

### Hints:

- You may need the help of another adult to keep these two parts in the correct position.
- You may want to position the steering column on a scrap block of wood to protect the assembly surface.

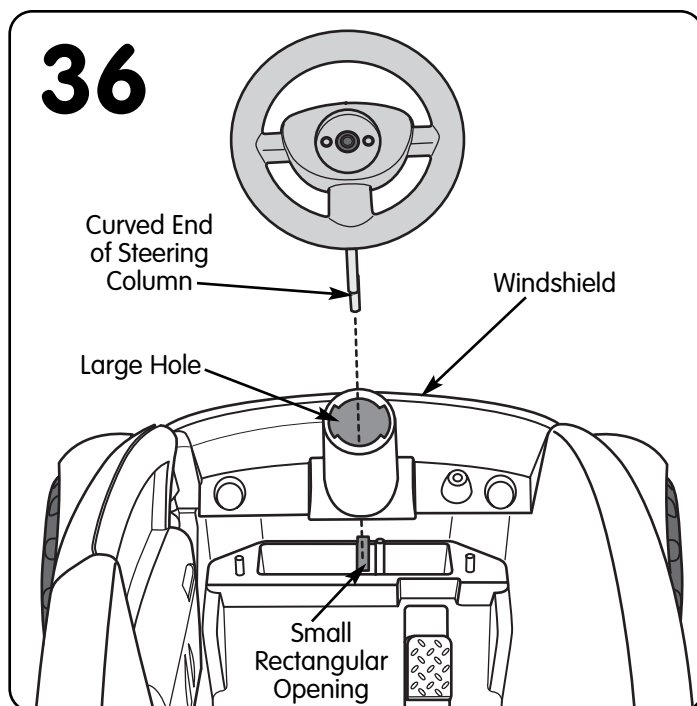

- With the large opening in the steering wheel upright, fit the curved end of the steering column down into the large hole in the windshield.
- Continue to insert the curved end of the steering column through the small, rectangular opening in the floor of the vehicle body.

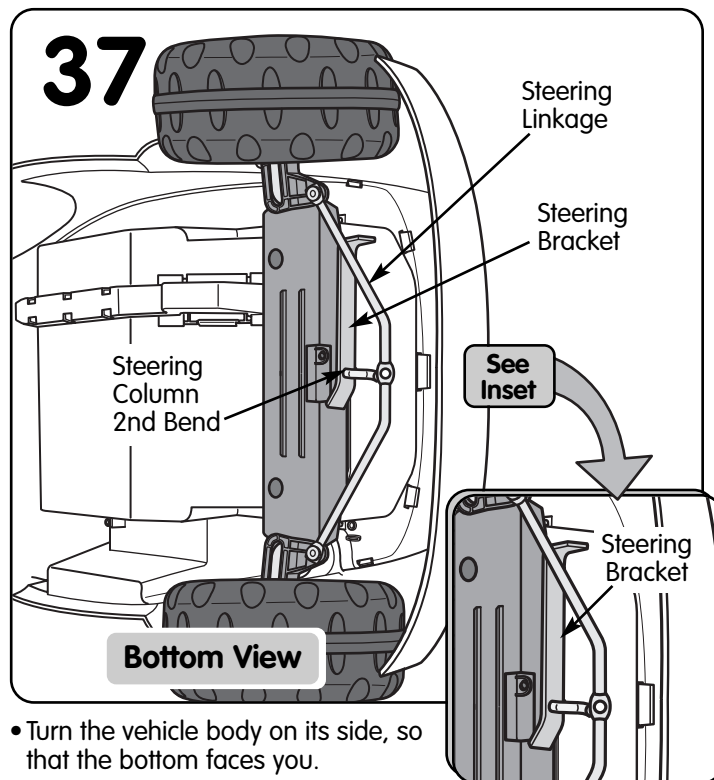

- Turn the vehicle body on its side, so that the bottom faces you.
- Position the steering bracket **behind** the steering linkage, as shown.
- Fit the steering column through the hole in the steering bracket to the second bend.

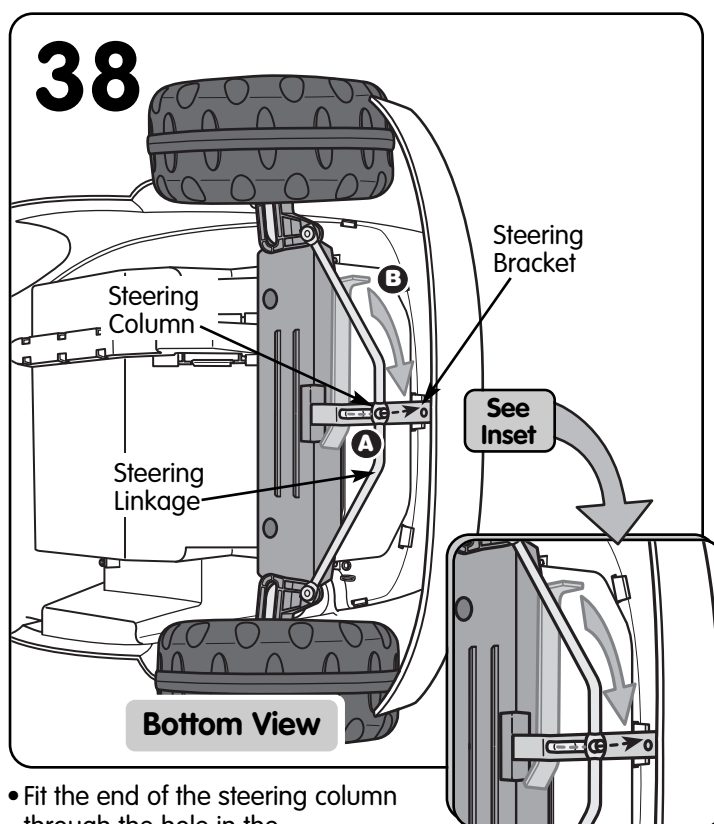

- Fit the end of the steering column through the hole in the steering linkage **A**.
- Turn the steering bracket and fit it into place **B**.

## Assembly

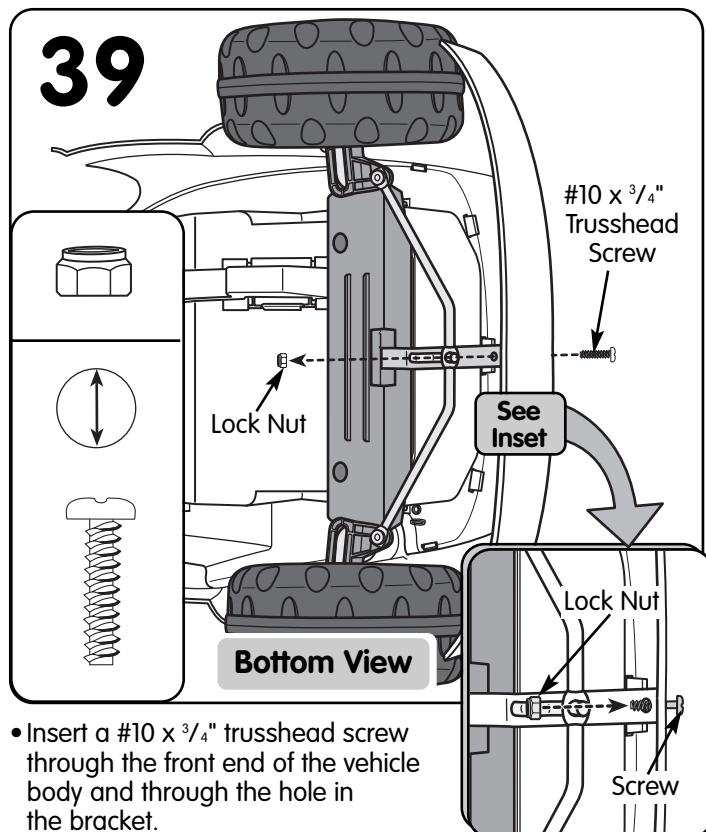

- Insert a #10 x  $\frac{3}{4}$ " trusshead screw through the front end of the vehicle body and through the hole in the bracket.
- Attach a lock nut to the end of the screw.
- While holding the locknut in place with an adjustable wrench, tighten the screw with a Phillips screwdriver. Do not over-tighten.

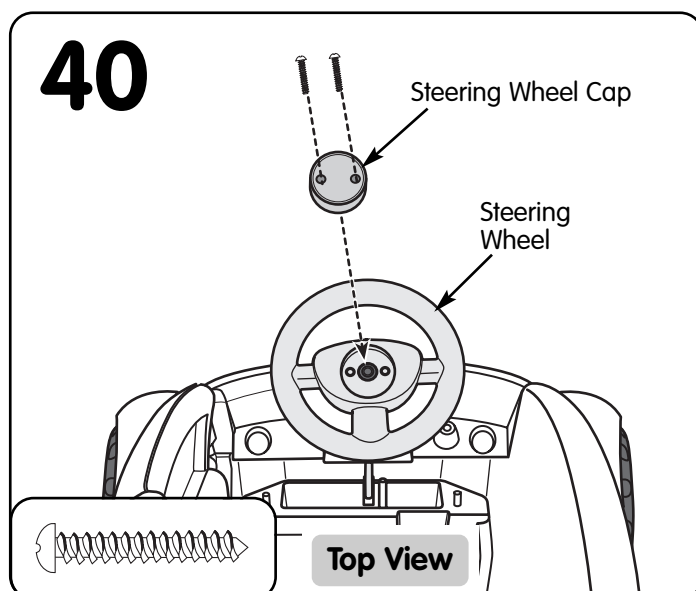

- Turn the vehicle body upright.
- Fit the steering wheel cap into the center of the steering wheel.
- Insert two #6 x 1" screws through the steering wheel cap and into the steering wheel. Tighten the screws.

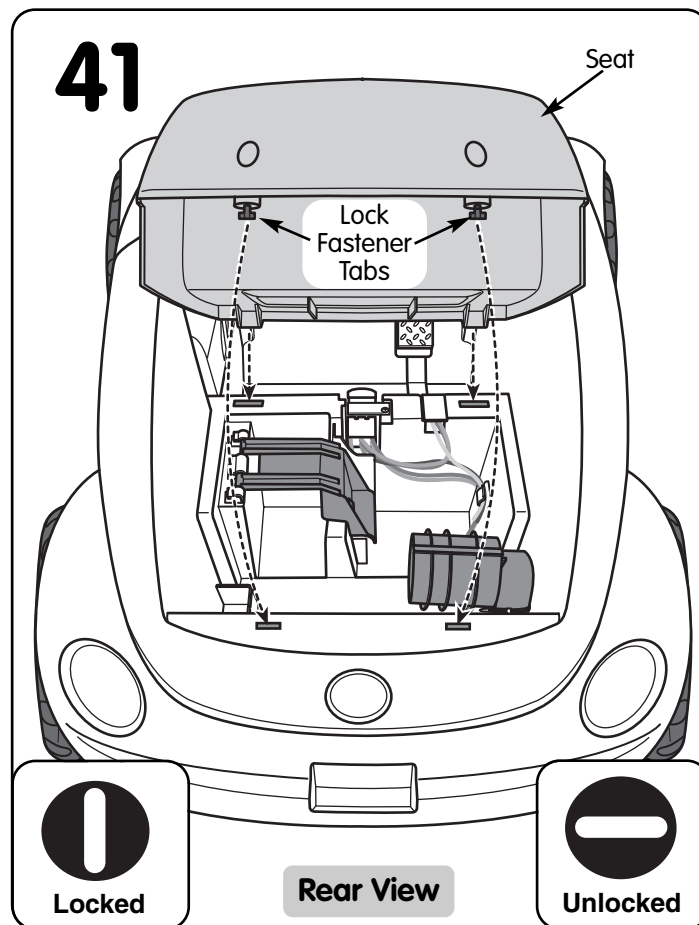

- Insert the seat front tabs into the slots inside the vehicle body.
- Then, insert the lock fastener tabs on the back of the seat into the slots in the vehicle body.
- Using a slotted screwdriver, turn each lock fastener  $\frac{1}{4}$  turn to the locked  position.

**IMPORTANT!** Remember to keep the lock fasteners locked at all times to prevent children from accessing the vehicle battery compartment.

**Assembly is now complete.**

**IMPORTANT!** Please carefully read the owner's information in this manual and teach your child about proper vehicle operation and rules for safe driving before allowing operation of this vehicle.

## G

## Label Decoration

Proper label application will help to keep the labels looking their best! When applying labels, keep the following guidelines in mind:

- Wash your hands before applying the labels.
- Before applying the labels, wipe the surface of the vehicle with a clean, dry cloth to remove any dust or oils.
- Place the labels exactly as shown in the illustrations.
- For best results, avoid repositioning a label once it has been applied to the vehicle.
- **After applying a label, rub the label firmly with a clean, dry cloth to make sure the label is adhered to your vehicle. Start at the center of a label, and smooth towards the outer edges to remove air bubbles.**

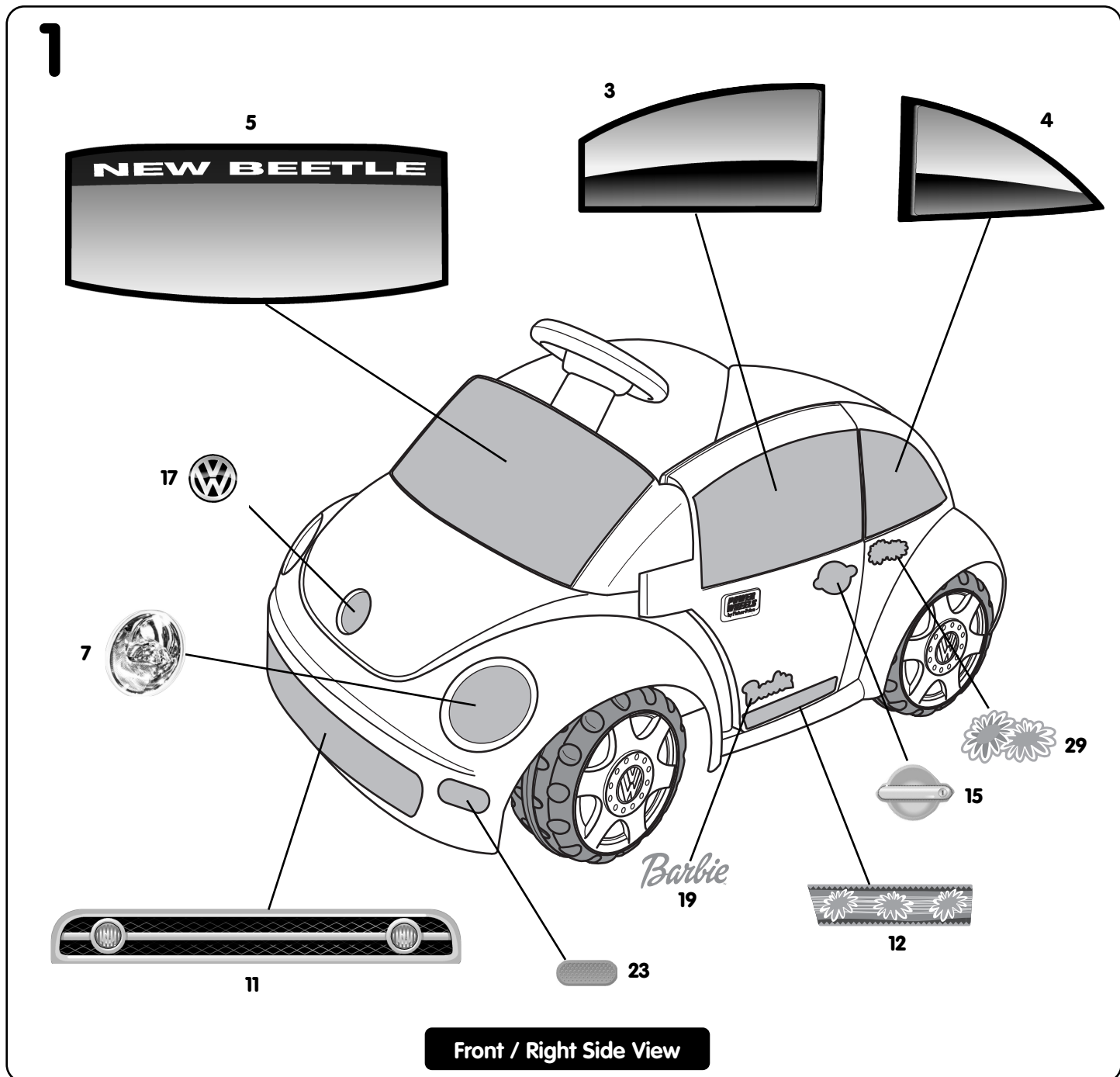

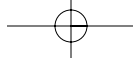

# Label Decoration

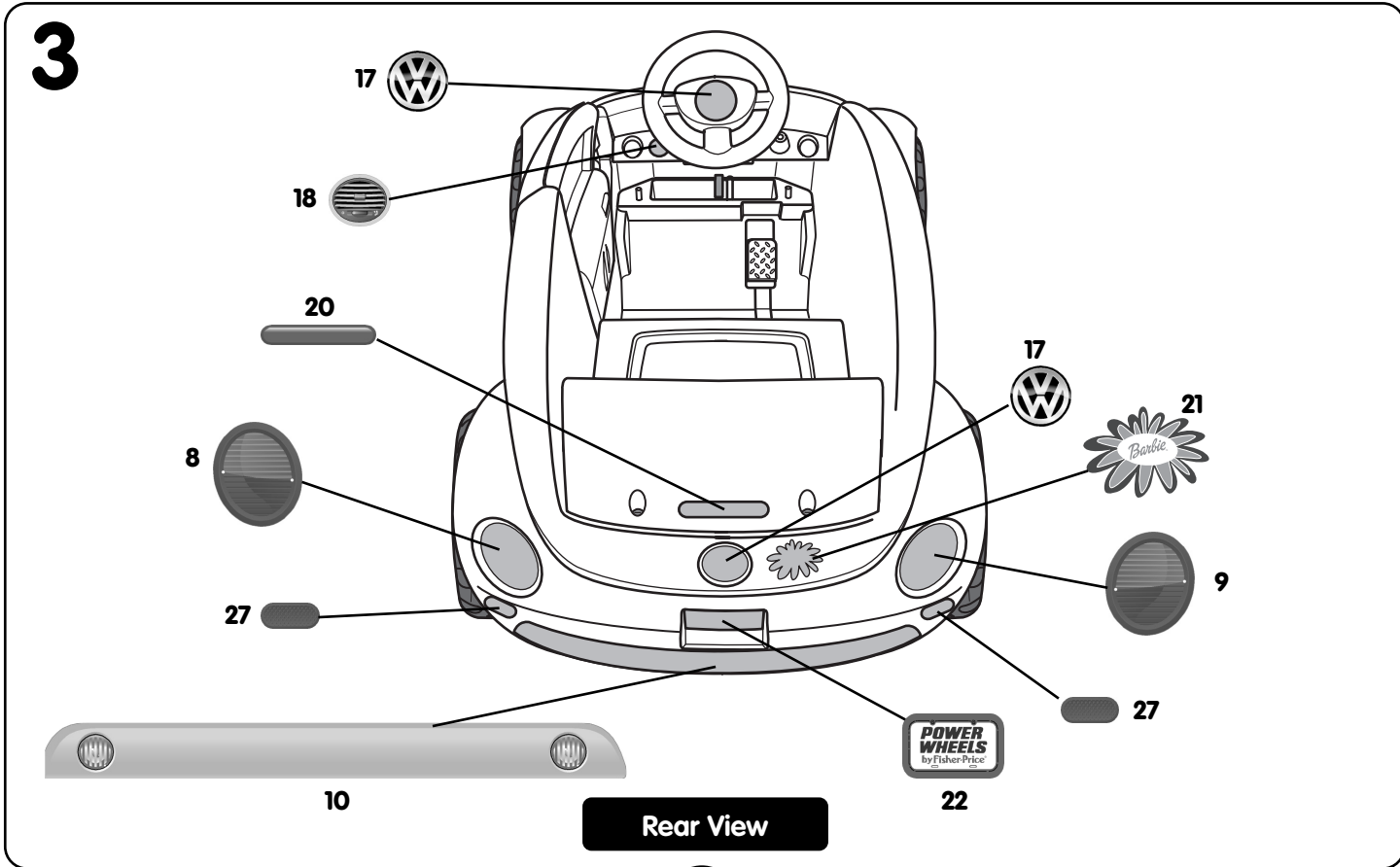
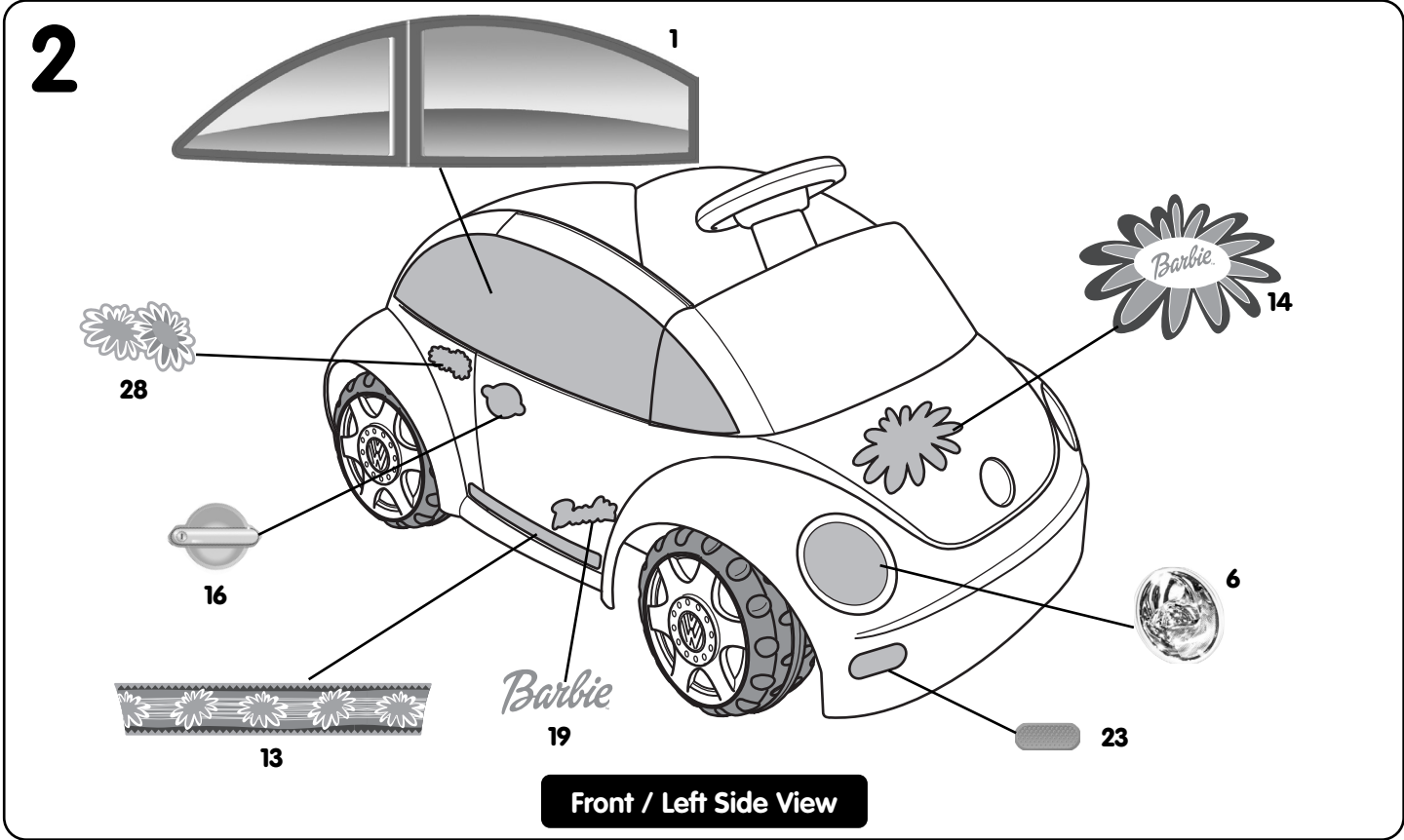



**23**

# H

## Battery Installation

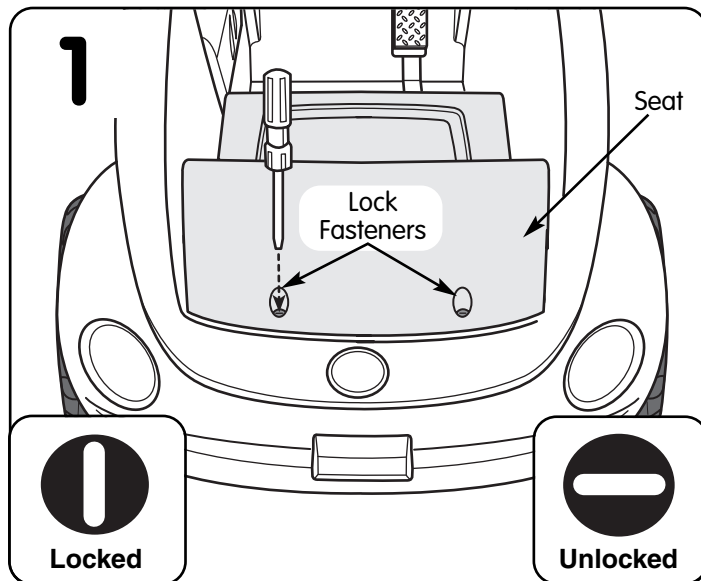
**IMPORTANT!** Use only a Power Wheels® Type H 6 volt battery with a Power Wheels® 25 Amp fuse installed. Use of any other battery or fuse will damage your vehicle. Make sure that you charge the battery for at least 18 hours using the enclosed Power Wheels® 6 volt charger before operating your vehicle for the first time. Charge the battery for at least 14 hours after each use of the vehicle. Never charge the battery longer than 30 hours. Failure to follow these instructions may damage your battery and will void your warranty.



- Locate the lock fasteners in the back of the seat.
- Using a slotted screwdriver, turn each lock fastener  $\frac{1}{4}$  turn to the unlocked  position.

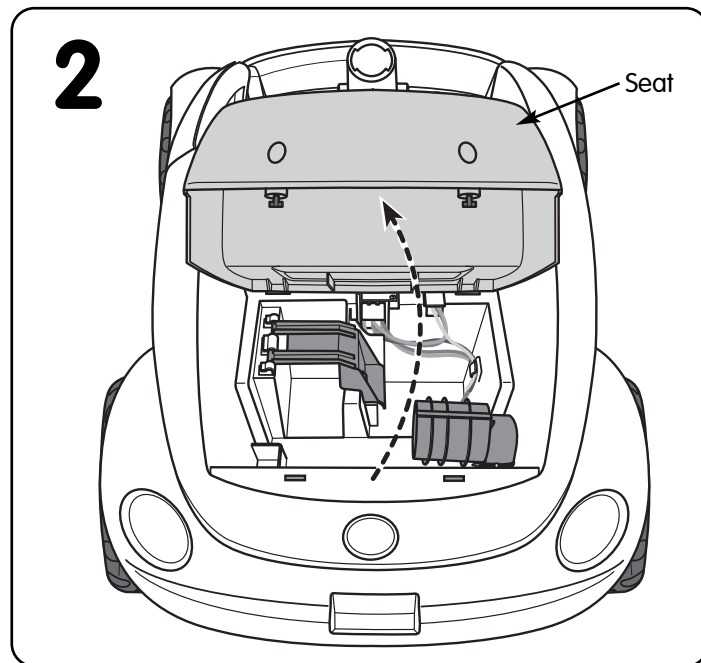

- Lift the seat to remove it from the vehicle body.

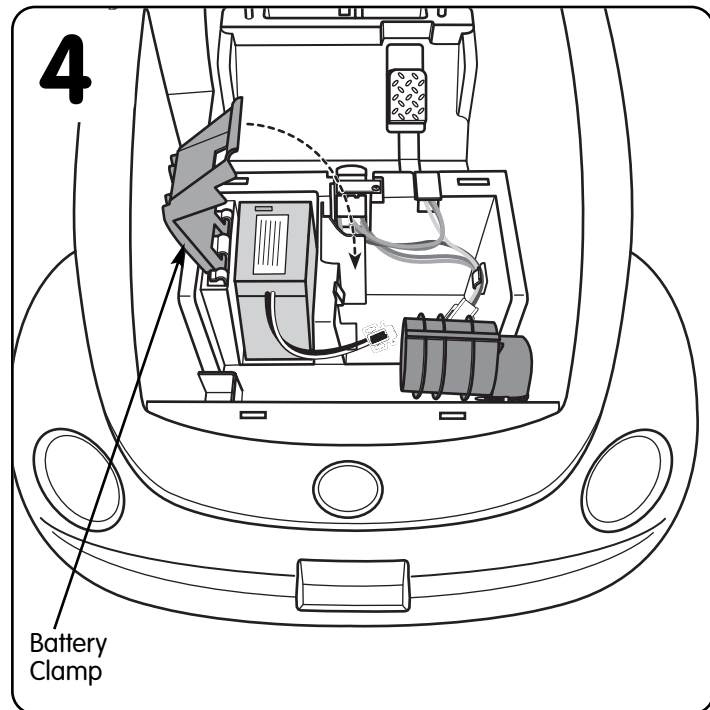
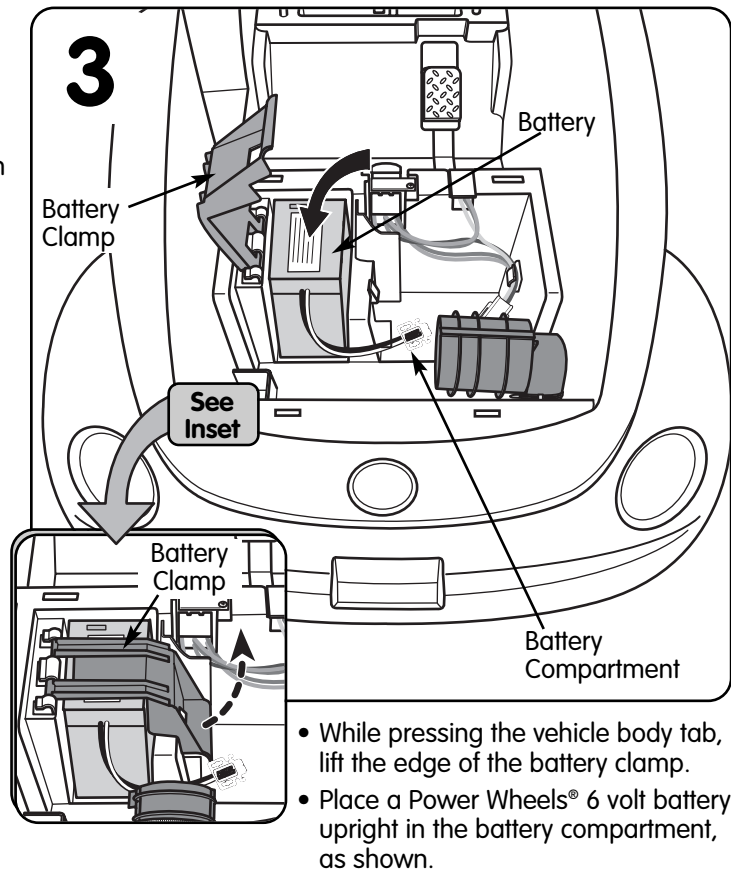



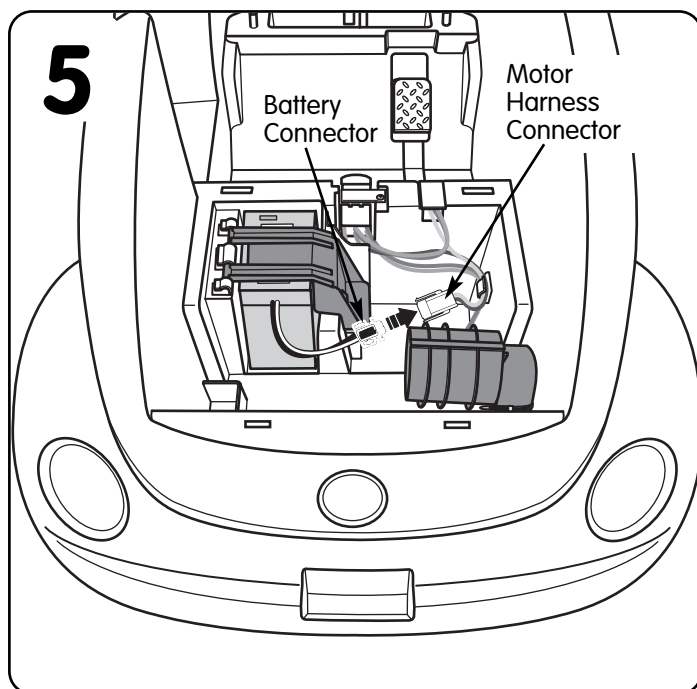

## Battery Installation

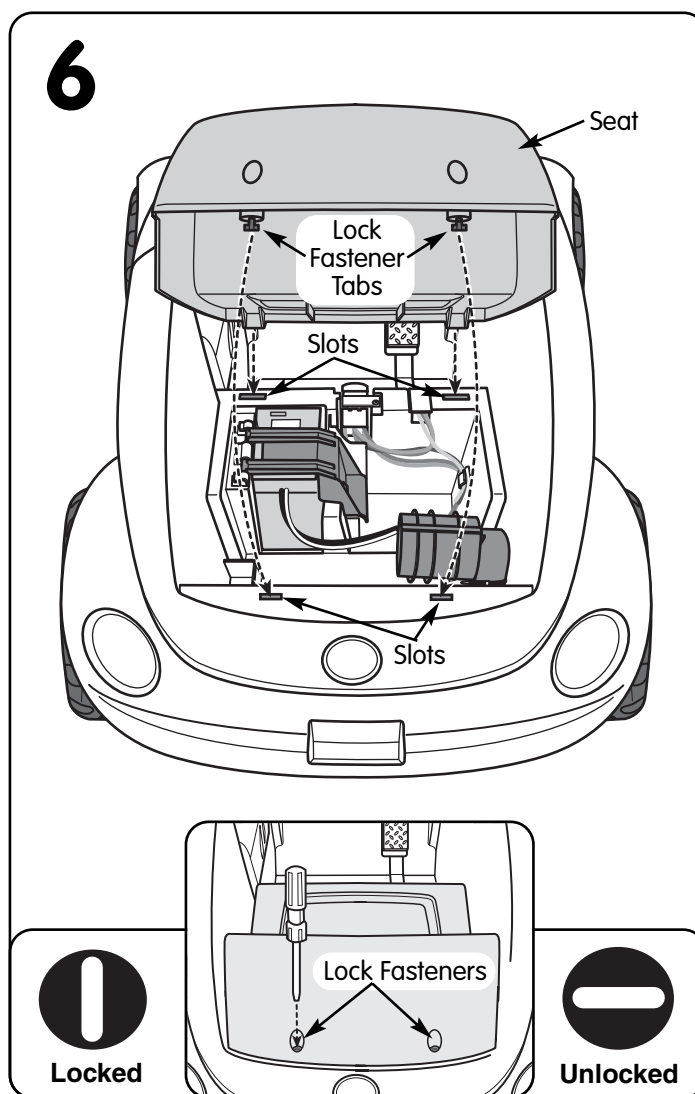

- Plug the battery connector into the motor harness connector.

**Note:** If the battery connector will not plug into the motor harness connector, turn it over and try again! Do not force the battery connector into the motor harness connector.



- Insert the seat front tabs into the slots inside the vehicle body.
- Then, insert the lock fastener tabs on the back of the seat into the slots in the vehicle body.
- Using a slotted screwdriver, turn each lock fastener  $\frac{1}{4}$  turn to the locked  position.

**IMPORTANT!** Remember to keep the lock fasteners locked at all times to prevent children from accessing the vehicle battery compartment.

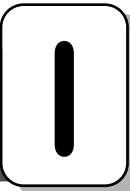

## Battery Care and Disposal

### Care

**If a battery leak develops,** avoid contact with the leaking acid and place the damaged battery in a plastic bag. See information below for proper disposal.

**If acid comes in contact with skin or eyes,** flush with cool water for at least 15 minutes and call a physician.

**If acid is internally ingested,** give water, milk of magnesia or egg whites immediately. Never give emetics or induce vomiting. Call a physician.

- Charge a new battery for at least 18 hours before first use. Never charge the battery longer than 30 hours. Overcharging or undercharging the battery may shorten battery life and decrease vehicle running time.
- After the first charge, recharge the battery for at least 14 hours after each use. Never charge the battery longer than 30 hours. Charge the battery after each use, regardless of how long the vehicle was used.
- The battery must be upright while charging.
- Do not allow the battery to run down completely before charging.
- Charge the battery before storing the vehicle.
- Charge the battery at least once per month, even if the vehicle has not been used.
- Leaving the battery in a discharged condition will ruin it.
- Always remove an exhausted battery from the vehicle. Battery leakage and corrosion can damage the vehicle.
- Do not store the battery on a surface (such as a kitchen countertop) which could be damaged by the acid contained inside the battery. Take precautions to protect the surface on which you store the battery.
- Do not store the battery in temperatures above 75° F or below -10° F.
- Prevent the battery from moving freely inside the battery compartment. Always use the battery clamp to secure the battery in the battery compartment.
- Examine the battery, charger and their connectors for excessive wear or damage each time you charge the battery. If damage is detected, do not use the charger or the battery until you have replaced the worn or damaged part.

## Battery Care and Disposal

### Disposal



- Your Power Wheels® battery is a sealed lead-acid battery. It must be recycled or disposed of in an environmentally sound manner.
- Do not dispose of a lead-acid battery in a fire. The battery may explode or leak.
- Do not dispose of a lead-acid battery in your regular, household trash. The incineration, landfilling or mixing of sealed lead-acid batteries with household trash is prohibited by law in most areas.
- Return exhausted batteries to a federal or state approved lead-acid battery recycler, such as a Power Wheels® authorized service center, or a local seller of automotive batteries. For the service center location nearest you, please call 1-800-348-0751. Contact your local waste management officials for other information regarding the environmentally sound collection, recycling and disposal of lead-acid batteries. If you live in the State of Florida or Minnesota, it is prohibited by law for anyone to throw away lead-acid batteries in the municipal waste stream.



## Caring For Your Vehicle

- Check all screws, cap nuts and their protective coverings regularly and tighten as required. Check plastic parts on a regular basis for cracks or broken pieces.
- During snowy or rainy weather, the vehicle should be stored inside or under a protective cover. Remember to charge the battery at least once per month while your vehicle is not in regular use.
- Avoid operating the vehicle in wet or snowy conditions, and do not spray the vehicle with a hose. Do not wash the vehicle with soap and water. Water or moisture in the motors or electrical switches can cause them to corrode, and could cause switch or motor failure.
- Avoid operating the vehicle on sand, loose dirt or gravel. Sand, loose dirt or gravel in the motors or electrical switches can cause them to jam, and could cause switch or motor failure.
- The vehicle can be wiped down with a soft, dry cloth. For a shiny finish, you can wipe plastic parts with a non-wax furniture polish applied to a soft-cloth. Do not use automotive wax. Do not use soap and water or spray the vehicle with a hose.
- To ensure that your vehicle stays in good operating order, we recommend that you periodically have your vehicle checked by a Power Wheels® authorized service center. For the location of the authorized service center nearest to you, visit us on-line at [www.powerwheels.com](http://www.powerwheels.com).

# K

## Rules for Safe Driving

### RIDING HAZARD

#### WARNING

##### Prevent Injuries and Deaths

- Direct Adult Supervision Required.
- Keep Children Within Safe Riding Areas

These areas must be:

- away from swimming pools and other bodies of water to prevent drownings.
- generally level to prevent tipovers.
- away from steps, driveways, cars, roads and alleys.

#### Teach Safety Rules to Children

While children can quickly develop the skill necessary to drive this vehicle, it is important to remember that their judgment skills are still very immature. Unsupervised driving by children can lead to serious injury. Before children use this vehicle, an adult should carefully evaluate the driving area as well as the children's skill level and ability to drive this vehicle safely. Children are not always able to recognize or anticipate hazards, even when they have been taught about them.

**THERE IS NO ACCEPTABLE SUBSTITUTE FOR DIRECT ADULT SUPERVISION.**

Teach appropriate safety rules to your child before allowing operation of this vehicle. These rules should also be reviewed with neighborhood children or other playmates who want to drive this vehicle.

#### Riding Rules

**Make sure children know and follow these rules for safe driving:**

1. Always sit on the seat.
2. Always wear shoes.
3. Only 1 (one) rider at a time. A child who is not sitting on the seat or who is standing on the vehicle could fall off, cause a tip-over or block the driver's view. A child could be seriously injured.
4. Do not allow any child to drive the vehicle in the street or near moving (motorized) vehicles.
5. Do not allow any child to drive near bodies of water (such as pools or creeks), obstructions (such as furniture, low tree limbs or play equipment), or drop-offs (such as stairs or decks).
6. Do not allow any child to drive the vehicle in the dark. A child could encounter unexpected obstacles and have an accident. Operate the vehicle only in the daytime or a well-lit area.

7. Do not allow your child to drive on sloped or inclined surfaces. **Restrict your child's driving to generally level ground ONLY!**
8. Do not allow your child to drive down or across a steep slope.
  - The vehicle may gain unsafe speed, even if the pedal is released to stop.
  - The vehicle may tilt and tip over.
  - The wheels could lose traction, causing the vehicle to slip.
9. Do not allow your child to drive up steep inclines. The motor may stop and the vehicle could roll backwards at an unsafe speed.
10. Never put anything near any moving parts. Rotating parts such as motors, gear boxes and wheels can snag fingers, hair, etc., causing serious injury. Do not allow operation of the vehicle when it is on its side or in an upside-down position.
11. Do not operate the vehicle near flammable vapors (gasoline, paint thinner, acetone, liquid wax, etc.). The vehicle's electrical switches, like most electrical switches, emit an internal spark when first turned on or turned off. The presence of flammable liquids or vapors could cause an explosion or a fire. Keep all flammable products in tightly sealed containers and away from the vehicle.
12. Do not allow a child to operate the vehicle without direct adult supervision. To prevent unsupervised use of the vehicle, disconnect the motor harness from the battery when the vehicle is not in use.

## L

## How to Operate Your Vehicle

**IMPORTANT!** Use this vehicle **ONLY** outdoors. Most interior flooring can be damaged by riding this vehicle indoors. Fisher-Price® will not be responsible for damage to floors if the vehicle is used indoors.

### Drive Forward

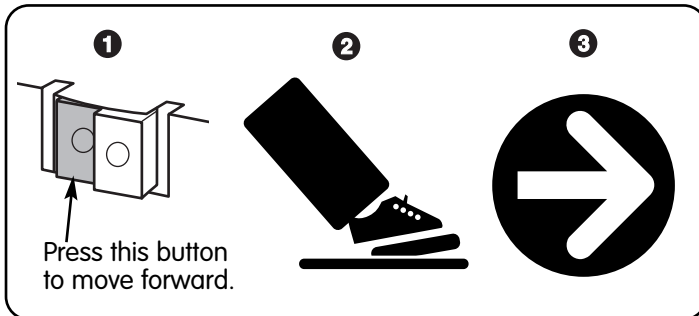

- Press the **FORWARD** ① button below the seat.
- Press the foot pedal ②. The vehicle will drive forward at a maximum of 2.5 mph ③.

### To Stop



- Your vehicle has a patented, electronic braking system that automatically stops the vehicle when your child's foot is lifted from the pedal.
- Make sure your child is comfortable with steering the vehicle and automatically knows how to stop.

### Reverse

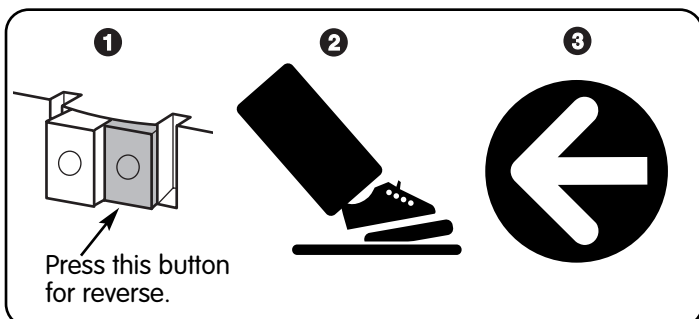

**IMPORTANT!** To avoid damaging the motors and gears, be sure to stop the vehicle before switching from forward to reverse.

- Press the **REVERSE** ① button below the seat.
- Press the foot pedal ②. The vehicle will back up at a maximum of 2.5 mph ③.

## M

## Bumper-to-Bumper\* Limited Warranty

**\*One year limited warranty from the date of purchase on the Power Wheels® vehicle.**

**Six month limited warranty on the 6 volt battery.**

For the original purchaser, this one year limited warranty covers the Power Wheels® ride-on vehicle (purchased from Power Wheels®) against defects in materials and workmanship. The six month limited warranty applies only to the 6 volt battery included by Power Wheels® with the original purchase of the vehicle.

This warranty covers normal use and does not cover the Power Wheels® vehicle or battery if damaged by unreasonable use, neglect, accident, abuse, misuse, improper service or other causes not arising out of defects in materials or workmanship. Evidence of any attempt at consumer repair will void this warranty. **THIS WARRANTY DOES NOT COVER, AND IS INTENDED TO EXCLUDE, ANY LIABILITY ON THE PART OF POWER WHEELS®, WHETHER UNDER THIS WARRANTY OR IMPLIED BY LAW FOR ANY INDIRECT OR CONSEQUENTIAL DAMAGES FOR BREACH OF WARRANTY. SOME STATES DO NOT ALLOW THE EXCLUSION OR LIMITATION SO THIS LIMITATION MAY NOT APPLY TO YOU.**

Should you need service or assistance with your vehicle during the warranty period, **do not return the vehicle to the store.** Power Wheels® has provided a nationwide network of authorized service centers. Power Wheels® is continually expanding our Authorized Service Center Network. If there is not an authorized service center in your area, please call Consumer Relations for information, **1-800-348-0751**.

**THIS WARRANTY GIVES YOU SPECIFIC LEGAL RIGHTS, AND YOU MAY ALSO HAVE OTHER RIGHTS WHICH MAY VARY FROM STATE TO STATE.**

**PLEASE SAVE YOUR ORIGINAL SALES RECEIPT.**



## Problems and Solutions Guide

**IMPORTANT!** If you experience a problem with your vehicle, first check the Problems and Solutions Guide below. If you still experience a problem, please contact Power Wheels® Consumer Relations, toll-free at **1-800-348-0751** between 8 AM and 6 PM (EST) Monday through Friday. Or, contact your local Power Wheels® authorized service center. For the location nearest you, please visit us on-line at [www.powerwheels.com](http://www.powerwheels.com).

Problem	Possible Cause	Solution
Vehicle does not run	Undercharged battery	Charge the battery. A new battery should have been charged for at least 18 hours before using the vehicle for the first time. After first-time use, recharge the battery for at least 14 hours after each use. Never charge the battery longer than 30 hours.
		Check all connectors. Make sure the charger connector is plugged into the battery, and that the charger is plugged into the wall.
		Make sure power flow to the wall outlet is "ON".
	Charger is not working	There is no sure way to tell if your charger is working unless you have a volt meter. If you suspect there is a problem with your charger, contact your local Power Wheels® authorized service center. They can test your charger for you.
	Wrong type or improperly installed fuse	Make sure that the battery has a properly installed Power Wheels® 25 amp fuse before charging. Do not substitute parts.
	Blown fuse	Make sure that the fuse in the battery is in good condition. Replace a blown fuse with a Power Wheels® 25 amp fuse. Do not substitute parts.
	Loose wire or loose connectors	Check all wires and connectors. Make sure the motor harness connector is plugged into the battery, and that there are no loose wires around the motors.
	Dead battery	If your battery is old or if you have not followed Battery Care instructions, your battery may be dead. If you are unsure whether or not the battery is dead, you can have it tested at your local Power Wheels® authorized service center.
	Electrical switch damage	The electrical switches can become corroded due to exposure to water or moisture, or can jam due to loose dirt, sand or gravel. Contact your local Power Wheels® authorized service center for diagnosis and repair.
Motor damage	Contact your local Power Wheels® authorized service center for diagnosis and repair.	
Vehicle was running but suddenly stopped	Loose wire or loose connectors	Check all wires and connectors. Make sure the motor harness connector is plugged into the battery, and that there are no loose wires around the motors.
	Wrong type or improperly installed fuse	Make sure that the battery has a properly installed Power Wheels® 25 amp fuse installed before charging. Do not substitute parts.
	Blown fuse	Make sure that the fuse in the battery is in good condition. Replace a blown fuse with a Power Wheels® 25 amp fuse. Do not substitute parts.
	Vehicle is overloaded	Make sure you do not overload the vehicle by allowing more than 1 rider at one time, by exceeding the 50 lbs (23 kg) maximum weight capacity, or by towing objects behind the vehicle.
	Driving conditions are too stressful	Use only on generally level ground. Extreme temperatures can also affect run time.

## Problems and Solutions Guide

Problem	Possible Cause	Solution
Short run time (Less than 1 - 3 hours per charge)	Undercharged battery	Charge the battery. A new battery should have been charged for at least 18 hours before using the vehicle for the first time. After first-time use, recharge the battery for at least 14 hours after each use. Never charge the battery longer than 30 hours.
		Check all wires and connectors. Make sure the charger connector is plugged into the battery, and that the charger is plugged into the wall.
		Make sure power flow to the wall outlet is "ON".
	Overcharged battery	Do not charge the battery longer than 30 hours. If you suspect that your battery is damaged as a result of overcharging, contact your local Power Wheels® authorized service center. They can test your battery for you.
	Battery is old and will not accept full charge	Even with proper care, a rechargeable battery does not last forever. Average battery life is 1 to 3 years depending on vehicle use and use conditions. Replace the battery with a new Power Wheels® 6 volt rechargeable battery. Do not substitute parts.
	Wrong type or improperly installed fuse	Make sure that the battery has a properly installed Power Wheels® 25 amp fuse installed before charging. For best performance, do not use substitute parts.
	Driving conditions are too stressful	Use only on generally level ground. Extreme temperatures can also affect run time.
Vehicle runs sluggishly	Undercharged battery	Charge the battery. A new battery should have been charged for at least 18 hours before using the vehicle for the first time. After first-time use, recharge the battery for at least 14 hours after each use. Never charge the battery longer than 30 hours.
		Check all connectors. Make sure the charger connector is plugged into the battery, and that the charger is plugged into the wall.
		Make sure power flow to the wall outlet is "ON".
	Battery needs charging	After each use, the battery needs charging.
	Wrong type or improperly installed fuse	Make sure that the battery has a properly installed Power Wheels® 25 amp fuse installed before charging. For best performance, do not use substitute parts.
	Battery is old and will not accept full charge	Even with proper care, a rechargeable battery does not last forever. Average battery life is 1 to 3 years depending on the vehicle use and use conditions. Replace the battery with a new Power Wheels® 6 volt rechargeable battery. Do not substitute parts.
	Vehicle is overloaded	Make sure you do not overload the vehicle by allowing more than one rider at one time, by exceeding the 50 lb. (23kg.) maximum weight capacity, or by towing objects behind the vehicle.
	Driving conditions are too stressful	Use only on generally level ground.

## Problems and Solutions Guide

Problem	Possible Cause	Solution
Sometimes the vehicle doesn't run, but other times it does	Loose wire or connector	Check all wires around the motors and all connectors to make sure they are tight.
	Motor or electrical switch damage	Contact your local Power Wheels® authorized service center for diagnosis and repair.
When the foot pedal is pressed, the vehicle won't run without a push	Loose wire or connector	Check all wires around the motors and all connectors to make sure they are tight.
	"Dead Spot" on motor	Contact your local Power Wheels® authorized service center for diagnosis and repair.
Loud clacking or grinding noise from a motor-gearbox	Broken gears	Contact your local Power Wheels® authorized service center for diagnosis and repair.
Charger gets warm during use	It is normal for some chargers to get warm during use and is not reason for concern.	No action required.
		If your charger does not get warm during use, it does not mean that it is not working properly.
Battery makes a sizzling or gurgling noise when charging	It is normal for some battery to make noise and swell slightly while charging and is not reason for concern.	No action required.
		If your battery does not make noise or swell slightly during charging, it does not mean that it is not accepting the charge.

If, after reviewing the Problems and Solutions Guide, the vehicle still fails to operate, please contact your nearest authorized service center or contact Power Wheels® Consumer Relations toll-free at **1-800-348-0751**.

# IMPORTANT!

**DO NOT use this vehicle for the first time until you have charged the battery for 18 hours.**

Remember to...

- ✓ Insert a 25 amp fuse (included) into the battery.
- ✓ Charge the battery immediately after each use.
- ✓ Charge the battery once a month during storage, even if the vehicle has not been used.

Failure to follow these instructions will permanently damage your battery and void your warranty. Please refer to the Battery Care Section in this manual for more information.

# DO NOT Return your Vehicle to the Store !



Over 400  
Authorized Service Centers!  
Visit us on-line at  
[www.powerwheels.com](http://www.powerwheels.com)  
for the location  
nearest you.

If you are missing parts or need assistance,  
please call us toll-free:

**Power Wheels® Consumer Relations**  
**1-800-348-0751**

**8 AM - 6 PM EST, Monday through Friday.**

Or contact your local, **independently owned and operated**  
Power Wheels® Authorized Service Center.

For the location nearest you,  
visit us on-line at [www.powerwheels.com](http://www.powerwheels.com).



Fisher-Price and Power Wheels by Fisher-Price are U.S. trademarks of Mattel, Inc.  
Fisher-Price, Inc., a subsidiary of Mattel, Inc., East Aurora, New York 14052 U.S.A.  
©2003 Mattel, Inc. All Rights Reserved.

Trademarks, design patents and copyrights are used with the approval of the owner VOLKSWAGEN AG.  
BARBIE is a U.S. trademark of Mattel, Inc.



## Free Manuals Download Website

<http://myh66.com>

<http://usermanuals.us>

<http://www.somanuals.com>

<http://www.4manuals.cc>

<http://www.manual-lib.com>

<http://www.404manual.com>

<http://www.luxmanual.com>

<http://aubethermostatmanual.com>

Golf course search by state

<http://golfingnear.com>

Email search by domain

<http://emailbydomain.com>

Auto manuals search

<http://auto.somanuals.com>

TV manuals search

<http://tv.somanuals.com>