

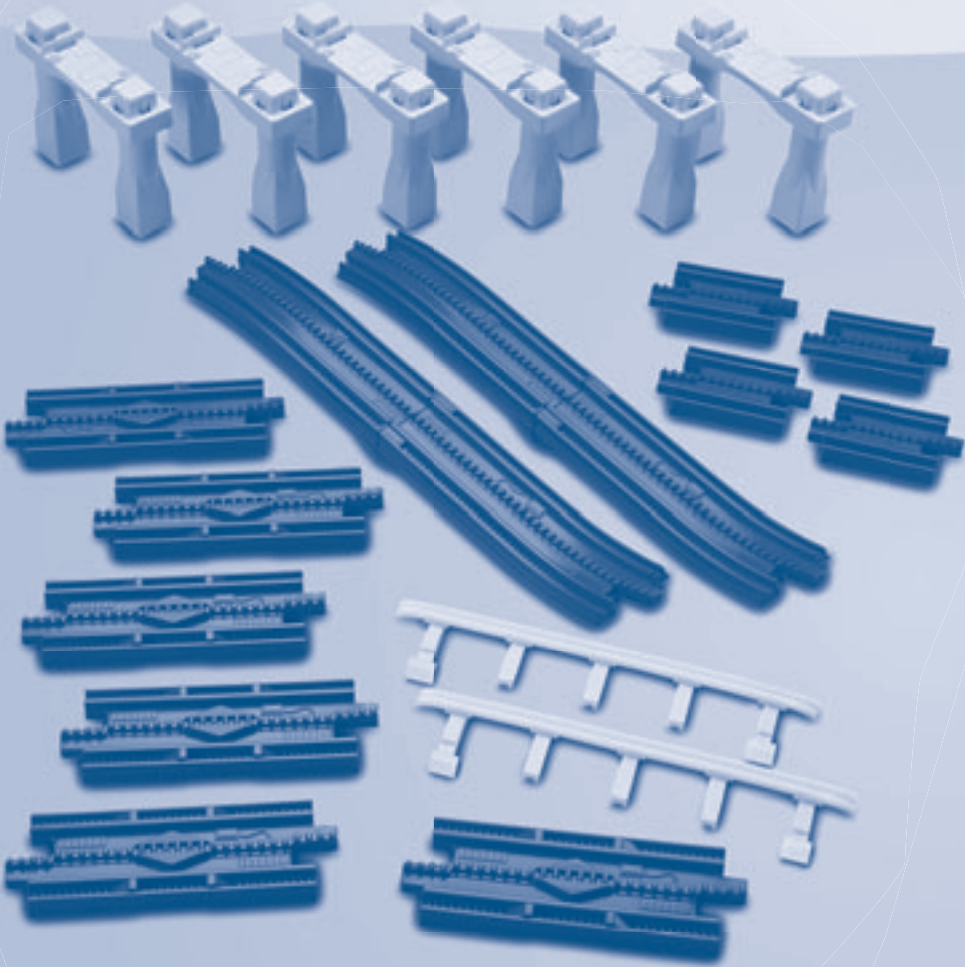

L9182

www.fisher-price.com



GeoTrax™

Rail & Road System

Assembly

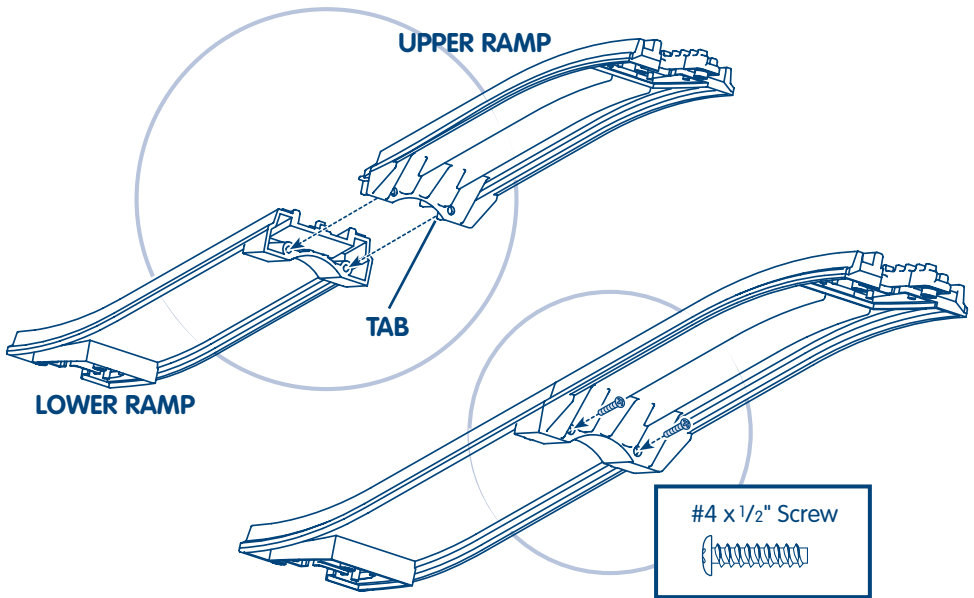

- Fit the tabs on an upper ramp into the slots in a lower ramp.
- Insert two screws into the upper ramp. Tighten the screws with a Phillips screwdriver. Do not over-tighten.
- Repeat this procedure to build the other upper/lower ramp assembly.

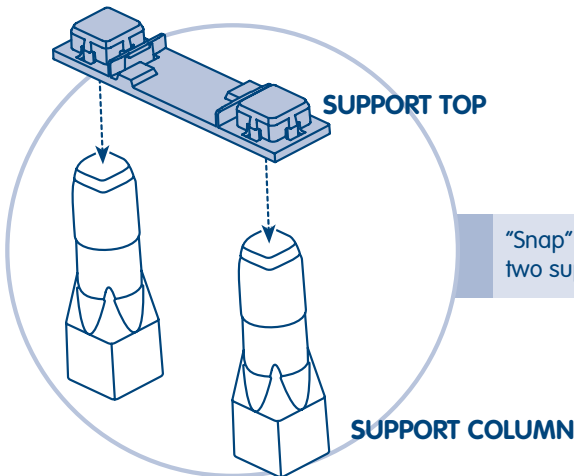

"Snap" a support top onto two support columns.

Elevation Track Tips

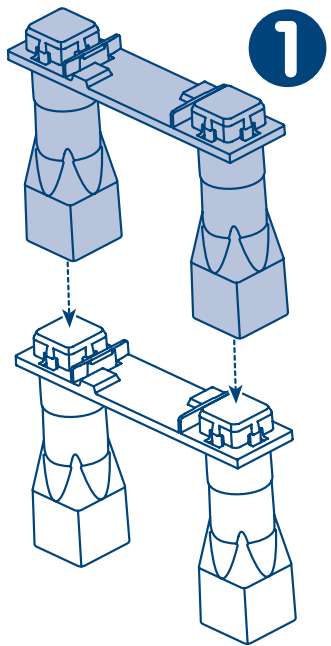

1

You can stack up support column assemblies to make a higher track layout.

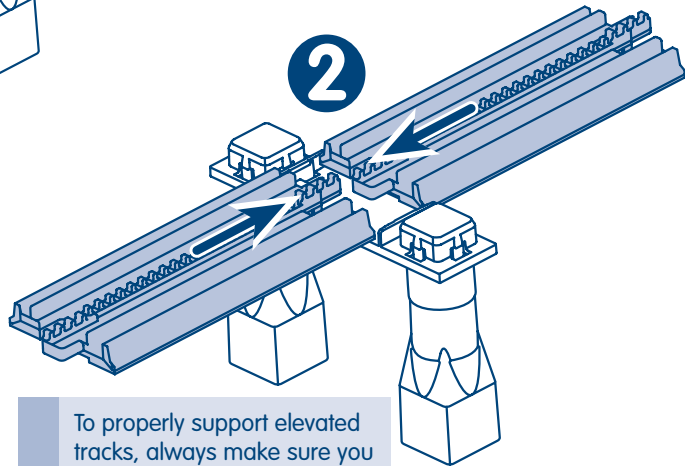

2

To properly support elevated tracks, always make sure you have support columns under track connections.

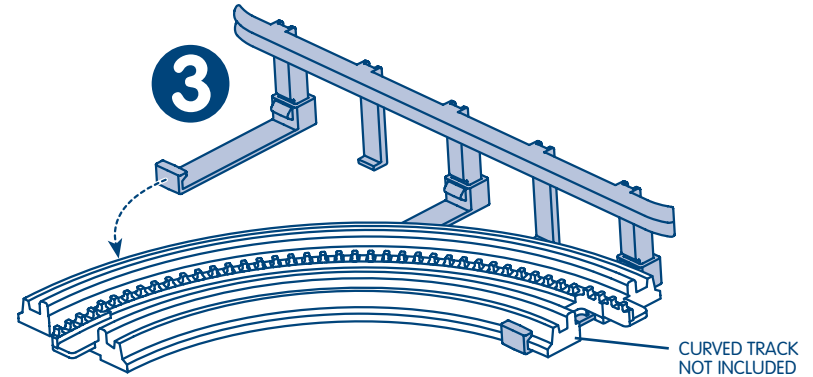

3

CURVED TRACK NOT INCLUDED

- When using a curved track (not included) at the bottom of a ramp assembly, be sure to use a guardrail on the curve. This keeps the fast moving train on the track!
- To attach the guardrail, fit a tab on one end of the guardrail under the curved track, as shown.
- Bend the guardrail slightly to fit the other two tabs to the curved track.

Parts

- A. 6 Straight Tracks
- B. 4 Short Tracks
- C. 6 Support Tops
- D. 2 Upper Ramps
- E. 2 Lower Ramps
- F. 12 Support Columns
- G. 2 Guardrails
- H. #4 x 1/2" Screw - 4

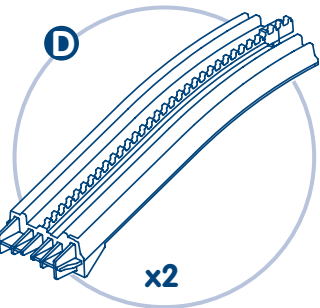
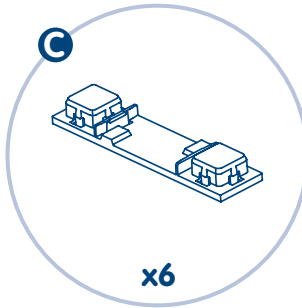
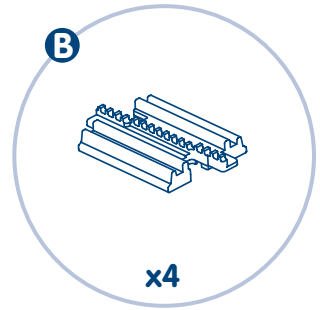
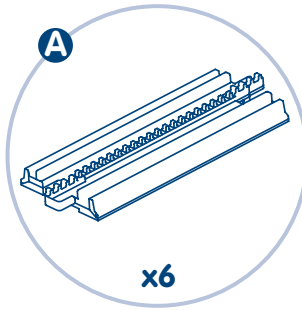

Please keep this instruction sheet for future reference, as it contains important information.

Adult assembly is required.

Tool required for battery installation: Phillips screwdriver (not included).

WARNING

This product contains small parts in its unassembled state. Adult assembly is required.

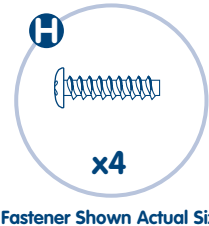
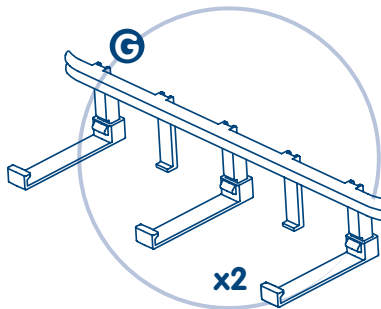
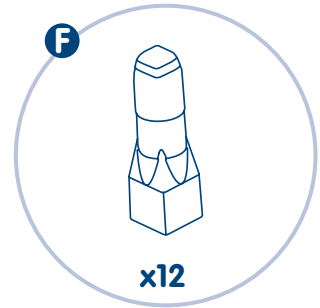
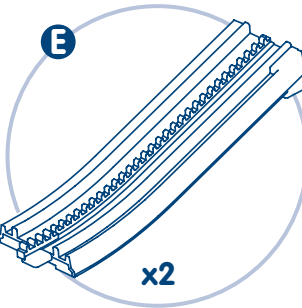

Fastener Shown Actual Size

Fisher-Price®



For layout ideas visit the
GeoTrax® section of
www.fisher-price.com



CONSUMER ASSISTANCE

Call toll free: 1-800-432-5437 (US & Canada only)
M-F 9AM to 7PM / SAT 11AM to 5PM (EST)

service.fisher-price.com

Write to us at: Fisher-Price® Consumer Relations,
636 Girard Avenue, East Aurora, New York 14052.

Hearing-impaired consumers using TTY/TDD equipment,
please call 1-800-382-7470.

For countries outside the United States:

Canada: Mattel Canada Inc., 6155 Freemont Blvd.,
Mississauga, Ontario L5R 3W2; www.service.mattel.com.

Great Britain: Mattel UK Ltd, Vanwall Business Park,
Maidenhead SL6 4UB. Helpline: 01628 500303.
www.service.mattel.com/uk

Australia: Mattel Australia Pty. Ltd., 658 Church Street,
Locked Bag #870, Richmond, Victoria 3121 Australia.
Consumer Advisory Service 1300 135 312.

New Zealand: 16-18 William Pickering Drive,
Albany 1331, Auckland.

Asia: Mattel East Asia Ltd, Room 1106, South Tower,
World Finance Centre, Harbour City, Tsimshatsui, HK, China.

Free Manuals Download Website

<http://myh66.com>

<http://usermanuals.us>

<http://www.somanuals.com>

<http://www.4manuals.cc>

<http://www.manual-lib.com>

<http://www.404manual.com>

<http://www.luxmanual.com>

<http://aubethermostatmanual.com>

Golf course search by state

<http://golfingnear.com>

Email search by domain

<http://emailbydomain.com>

Auto manuals search

<http://auto.somanuals.com>

TV manuals search

<http://tv.somanuals.com>