



KICKER®



SIGNAL PROCESSORS

SX AMPLIFIER REMOTE CONTROL

WIN LOUD

OWNER'S MANUAL

SXRC

SX AMPLIFIER REMOTE CONTROL

KICKER®



SX Series SXRC Remote Control Owner's Manual

SX Series Amplifier Remote Control: **SXRC**

Attention:

Please record your purchase information in the area provided below. We recommend attaching the original sales receipt or a copy of it to this manual for future reference.

If you require service on this remote control during the warranty period, you will need to provide this information and a copy of the receipt to Kicker to validate your warranty.

ALWAYS KEEP YOUR RECEIPT!

Congratulations!

You have just purchase the latest in microprocessor powered amplifier control technology to carry the famous KICKER name. Your KICKER SXRC is designed and built to give you years of unmatched control, flexibility and trouble-free performance in the judging lanes and on the street.

Please read this installation manual, it contains valuable information to help you get the most out of your new SXRC Remote Control.

This is your "Fuel for Livin' Loud"™ "!

Dealer Where Purchased: _____

Purchase Date: _____

Model Number: _____

SXRC _____

Ok...we know you are chomping at the bit to get this new toy plugged in and working but there are some initial steps you will have to take before you can use your SXRC with your SX Series amplifiers.

After you follow the instructions for mounting and wiring your SXRC into your system you will have to perform these steps before you can use your SXRC.

1.) **SET EACH OF YOUR SX AMPLIFIERS TO A UNIQUE COMMUNICATION ADDRESS.**

In order for the SXRC to properly communicate with all your SX Series amplifiers, each amplifier must have its own unique Communication Address.

2.) **PERFORM A SOFTWARE UPGRADE TO ALL OF YOUR SX SERIES AMPLIFIERS!**

The SXRC has new software (Version 3.00) loaded into it for all SX Series amplifiers. By using a one-at-a-time process, each of your amplifiers will need to be updated to Version 3.00 so that all SXRC functions work properly.

So get your initial mounting and wiring done but keep in mind that **BOTH** of the steps outlined above **MUST** be performed before your SXRC will work properly with your SX Series amplifiers.

PLEASE read the entire manual so you are aware of **ALL** the steps required for this procedure.

A Brief Plug For The SXRC SX Amplifier Remote Control And Our Support Materials At www.KICKER.com

The SXRC is a component we envisioned from the start to compliment your KICKER SX Series amplifier. That is why all SX Series amplifiers have been built from day one with the ability to be controlled remotely...and now you have the tool to do so, the SXRC. The SXRC incorporates the latest in microprocessor technology which allows you to not only update the software in your SX Series amplifier (*so you are always on the cutting edge*) but also group, diagnose and control them in a way never before possible in the car audio world. This technological marvel is loaded with diagnostic and control features that literally put the SX Series amplifier controls at your fingertips from the driver's seat...plus a whole lot more! **PLEASE** read this manual so you have a thorough understanding of the capabilities, installation and operation of your SXRC. Also, sometimes things change, we find things we overlooked or a customer points out a mistake we made when writing this manual. When in doubt, always check out the SUPPORT section at www.KICKER.com for the latest information. If we change anything in this manual, or add to it, you will always find the latest version available for download there. Last but not least...grab a cold beverage, kick back and read about this latest creation from the Livin' Loud Labs. Enjoy!

Full Control Of SX Amplifiers The SXRC gives you complete access to all settings and diagnostic tools for up to 16 KICKER SX Series amplifiers.

ISIS Display Indicate Status & Input Settings ISIS is a VFD (Vacuum Fluorescent Display), 5-way soft-touch keypad and 4 memory presets that allows you to view any current settings and make changes to your SXRC and the connected amplifiers.

SXRC Name The name of the SXRC is displayed in the default screen scrolling menu. Name is 'SXRC' by default but can be changed by you to any name using up to 10 characters.

Digital Remote Volume Control (DRVC) Allows instant control of the output level of selected amplifiers. The current setting of the digital remote volume control is displayed in the default screen scrolling menu.

Number Of Units Under SXRC Control The number of amplifiers currently being controlled by the SXRC is displayed in the default screen scrolling menu.

Real Time Calendar & Clock The SXRC is capable of displaying the current date and time and is user adjustable.

Amplifier Temperature Display Selected amplifier's current temperature is displayed in the default screen scrolling menu. All amplifiers can be viewed through SickBay™.

Amplifier Voltage Display Selected amplifier's current voltage is displayed in the default screen scrolling menu. All amplifiers can be viewed through the SickBay™.

Amplifier Adjustment Allows you to individually select and adjust any setting on any amplifier controlled by the SXRC.

Amplifier Grouping & Group Adjustment Allows you to build groups of amplifiers which can then share similar settings and be adjusted all at once. Great for multiple sub amps, front stage, rear stage, etc!

SickBay™ Allows you to view operation history and use diagnostic tools on any amplifier connected to the SXRC.

SXRC Setup Allows you to setup and adjust many options for the SXRC like ISIS display brightness, lock codes, amp names, memory names, etc. See details further in the manual.

Security Mode Allows you to 'Lock' and 'Unlock' your SXRC and connected SX amplifiers to prevent un-authorized adjustments.

Global Memory Presets Allows you to store and recall up to 4 memory settings for all amplifiers connected to the SXRC.

DIN Sized Control Head The controller for the SXRC is very thin and includes hardware to be mounted in a standard DIN sized opening.

PARTS LIST

Here is a breakdown of the components and accessories included with your SXRC Remote Control kit.

SXRC Control Head This is the DIN sized unit used to control the SXRC and your SX amplifiers. It includes an attached 1 meter long 6-pin DIN cable. This cable is also referred to as a PS2 cable and you can use an extension (Male to Female) cable to lengthen the cable if required (not included).

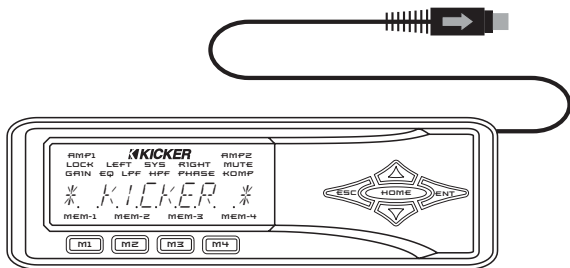

SXRC Interface Box This small enclosure provides the power connections for the SXRC as well as being the communication bridge between the Control Head and your SX Series amplifiers.

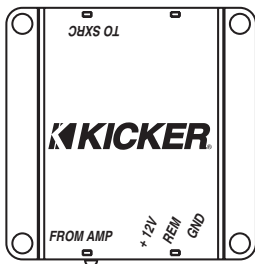

Metal DIN Mounting Cage This cage is designed to mount into a standard DIN sized opening and provide a solid mounting for your SXRC.

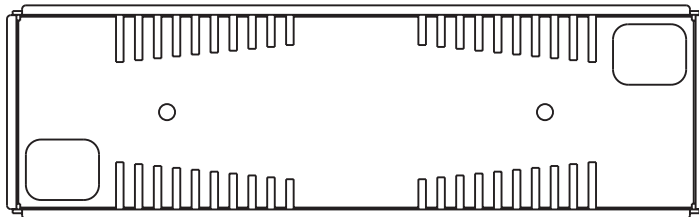

Plastic Cosmetic Trim Ring This ring trims out the DIN Mounting Cage and provides a professional finished look to your install.

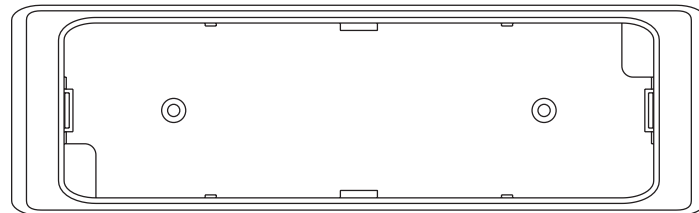

R-Tool Tool used to assist in removing the SXRC Control Head from the Plastic Cosmetic Trim Ring.

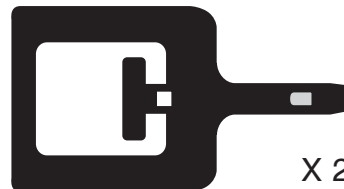

Mounting Hardware Includes four (4) sheet metal screws for mounting the Interface Box and two (2) M3 flathead screws to mount the Cosmetic Trim Ring to the DIN Mounting Cage.



Rubber Mounting Washers Includes four (4) rubber mounting washers to protect the mounting flange on the Interface Box.



One 5-Meter Network Cable This cable is used to create your SXRC Communications Network and connects your Interface Box to your first SX amplifier. This cable is known as a Straight-Through Ethernet Cable.

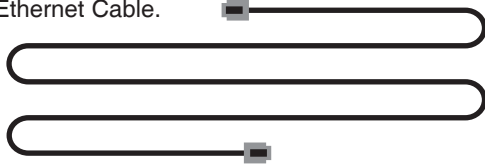

Two 1-Meter Network Cables These cables are used to connect additional SX Series amplifiers to the SXRC Communications Network. These cables are known as a Straight-Through Ethernet Cable.

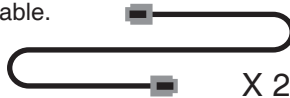

3 Amp Mini Glass Fuse Extra replacement fuse for use in SXRC Interface Box. See the Service section of this manual for replacement instructions



ISIS

The ISIS (Indicate Status & Input Settings) system consists of the VFD (Vacuum Fluorescent Display) and nine soft touch buttons that make up the Keypad. The ISIS allows you to view and adjust the settings of your SXRC and all of the SX Series amplifiers connected to it.

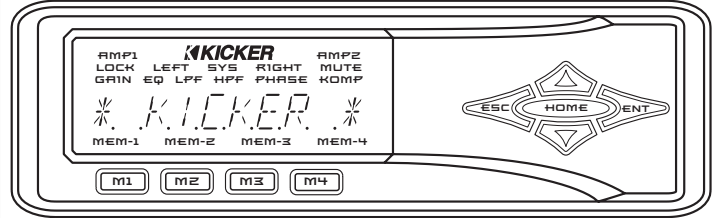

VFD DISPLAY

Here is a brief description of the indicators found on the VFD.

AMP1 - Indicates amplifier 1 is selected for adjustment. Only available with four channel amplifiers.

AMP2 - Indicates amplifier 2 is selected for adjustment. Only available with four channel amplifiers.

LOCK - Indicates the SXRC and/or SX Series amplifier controls are locked out and not usable.

LEFT - Indicates an action or adjustment of the left channel.

SYS - Indicates you are in the System Menu.

RIGHT - Indicates an action or adjustment of the right channel.

MUTE - Indicates you are in the mute menu or the mute function is active.

GAIN - Indicates you are in the gain menu.

EQ - Indicates you are in the equalizer menu.

LFF - Indicates you are in the low pass filter menu.

HPF - Indicates you are in the high pass filter menu.

PHASE - Indicates you are in the phase menu.

KOMP - Indicates you are in the Kompressor™ menu.

MEM-1 - Memory preset 1 activated or stored.

MEM-2 - Memory preset 2 activated or stored.

MEM-3 - Memory preset 3 activated or stored.

MEM-4 - Memory preset 4 activated or stored.

KEYPAD

Here is a brief description of the soft touch buttons.

 **M1** - Used to select memory preset 1 or to store current settings into memory preset 1.

 **M2** - Used to select memory preset 2 or to store current settings into memory preset 2.

 **M3** - Used to select memory preset 3 or to store current settings into memory preset 3.

 **M4** - Used to select memory preset 4 or to store current settings into memory preset 4.

 **ESC** - Used to exit the current menu.

 **ENT** - Used to enter the selected menu.

 **HOME** - Used to return to the Main Menu and other functions explained later in this manual.

 **UP** - Used to advance up through menu selections and/or adjust SXRC and amplifier controls.

 **DOWN** - Used to advance down through menu selections and/or adjust SXRC and amplifier controls.

These controls and their usage will be explained later with more detail in each menu usage section.

MOUNTING

DIN Mounting

Using the supplied hardware you can mount the SXRC into a standard DIN sized opening.

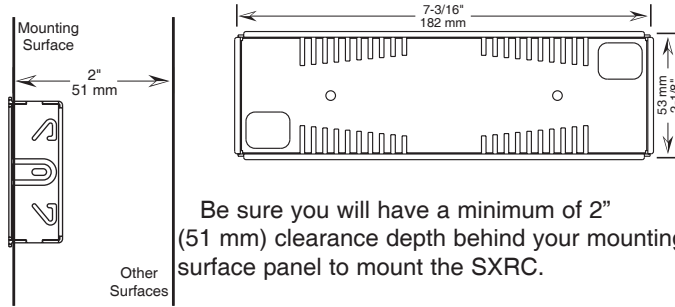

Be sure you will have a minimum of 2" (51 mm) clearance depth behind your mounting surface panel to mount the SXRC.

If not using an existing DIN opening, you will first need to cut an opening that is 7-3/16" (182 mm) by 2-1/8" (53 mm) into your mounting surface panel.

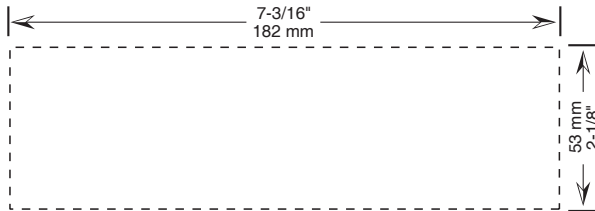

It is VERY important that you DO NOT make the hole any larger than the specified dimensions. If you make the opening too large then the mounting cage will not work properly.

Using the existing DIN opening or the one you just created, slide the Metal DIN Mounting Cage into the opening. Secure the Cage by bending the Mounting Tabs on the sides, top and bottom of the Cage using a small flat-blade screwdriver. Use only the tabs that when bent will secure the Cage to the Mounting Surface.

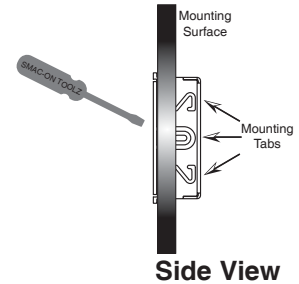

Side View

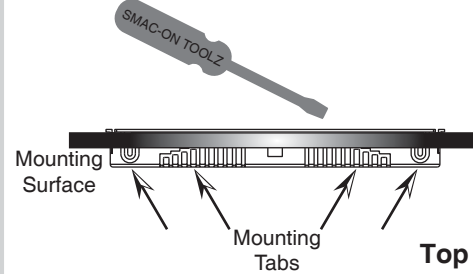

Top and Bottom View

Next, place the Plastic Cosmetic Trim Ring into the Metal DIN Mounting cage. There are two plastic retainers in the Trim Ring (one on top and one on bottom) that will snap into place.

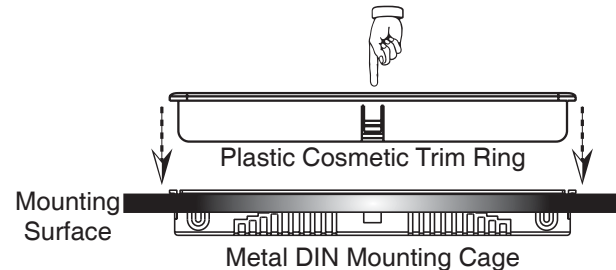

Once in place use the 2 supplied M3 flathead screws to secure the Trim Ring to the Metal Cage.

Trim Ring & Metal Cage Assembly
Front View

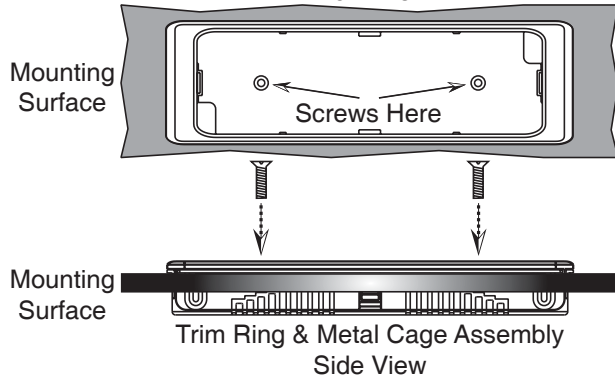

The SXRC Control Head is held in place by two clips (one on each side) of the Plastic Trim Ring.

SXRC Control Head
Mounting Clips

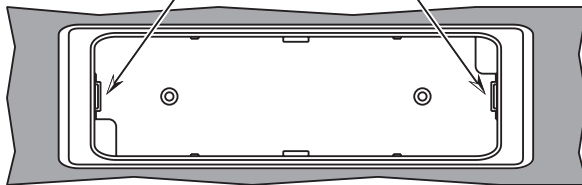

Route the SXRC Control Head cable through one of the openings in the Trim Ring/Metal Cage assembly to your SXRC Interface Box location.

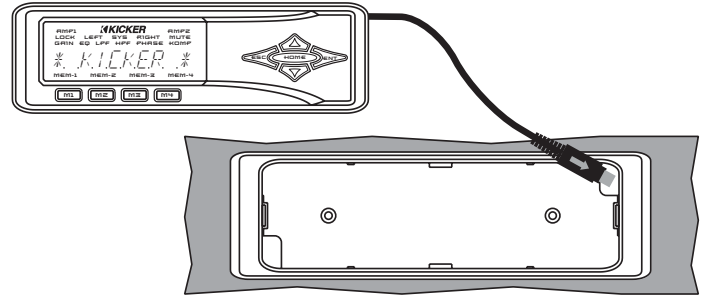

Press the SXRC control head in to the assembly until it locks into place.

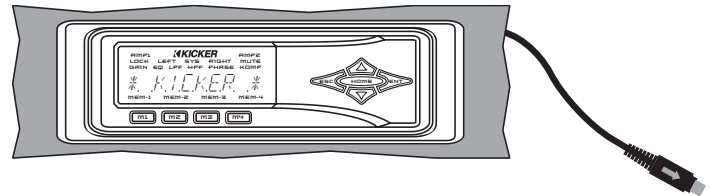

Your SXRC Control Head is now mounted and you can move on to the wiring section of this manual

Surface Mounting With Screws

The SXRC Control Head can also be surface mounted if you do not have a spare DIN opening in your dash or do not want to cut one into an existing panel.

The back of the SXRC Control Head has two metal inserts designed to work with M3 screws.

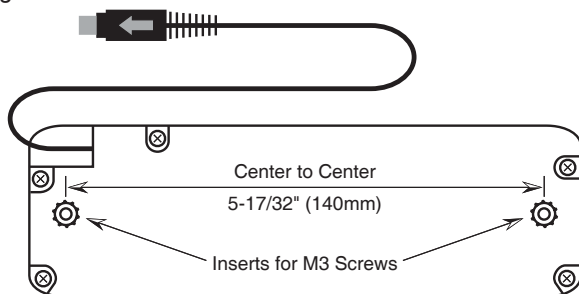

Find a suitable location and drill two 1/8 inch (3 mm) holes to secure the SXRC Control Head. The holes should be 5-17/32" (140 mm) apart from center to center.

NOTE: You will need to have access to the area behind this location to install the mounting screws.

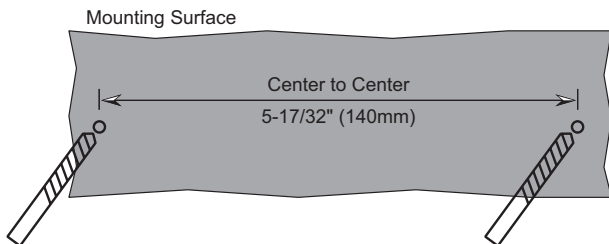

Once your holes are drilled you can use the two supplied M3 screws to secure the SXRC Control Head to your mounting surface. If the supplied screws are not long enough to reach the SXRC Control Head you can supply your own M3 screws of the required length to secure the SXRC.

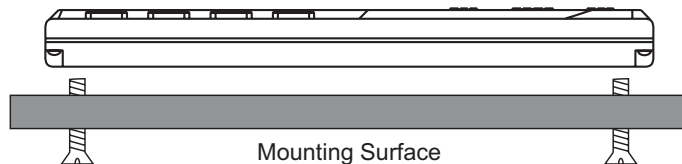

NOTE!!! Whether using the supplied M3 screws from the SXRC kit or your own, the screws can not enter into the SXRC more than 5/16" (4 mm). If you attempt to insert the screw any deeper than this into the SXRC Control Head you will run the risk of damaging the unit.

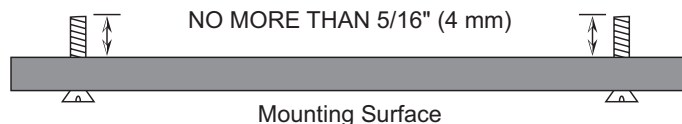

Route the SXRC Control Head cable to your SXRC Interface Box location. Your SXRC Control Head is now mounted and you can move on to the wiring section of this manual.

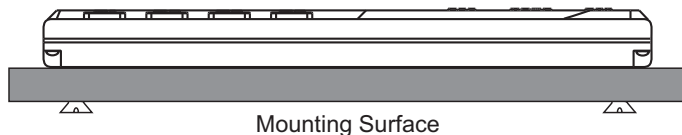

Surface Mounting With Velcro

If you do not want to cut any openings or drill any holes you can use a material such as Velcro™ to secure your SXRC Control Head to your dashboard or other mounting surface. Velcro™ is not supplied with your SXRC but can be obtained from any local fabric or retail store.

Velcro™ is a two piece product, one half is soft and fuzzy(loop) while the other is stiff and prickly (hook). Place a 5" (127 mm) strip of the loop half on the SXRC.

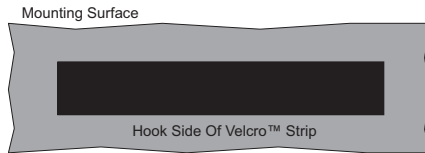
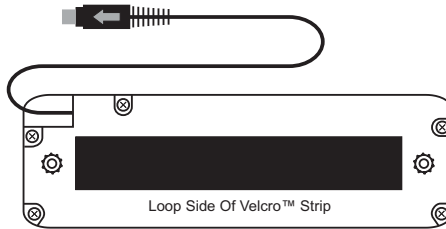

Place the 5" (127 mm) strip of the hook half on the mounting surface.

The SXRC Control Head will now be able to stick to the dash or other mounting surface. Route the SXRC Control Head cable to your SXRC Interface Box location. Your SXRC Control Head is now mounted and you can move on to the wiring section of this manual.

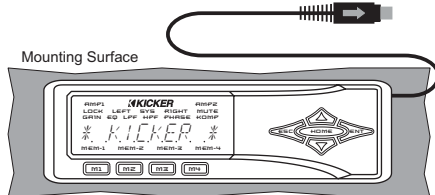

Got No Time For Mounting

If this is the case there are many options...ranging from 'Ok' to 'What are you thinking?'...and we do not recommend any of them. But we know some of you may use these...or a variation of them...so we included these for your entertainment. Got your own idea? E-mail them to questions@kicker.com, Attn: Hank.

In the center console. This one makes some sense as it keeps the SXRC in an 'easy to access' location while protecting it from your gym bag that gets tossed in the ride everyday for ball practice.

In the glove box. Another excellent choice for protection. Just be sure you run the SXRC Control Head cable through the back of the glove box...not out the front with the door pinching the wire.

Lay it in the seat. This allows quick and easy access to your SXRC...just be sure that your girl or best friend Larry does not sit on it when sharing your ride. Being 'sat on and squashed' is not covered under warranty.

Lay it in the catch-all pocket in your center console. This also allows quick and easy access to your SXRC...plus it adds another item to rattle along with all those nickels, dimes and quarters sitting there. Could be very harmonious.

Stand vertically in your cup holder. This is an excellent location that puts your SXRC within reach. Just be sure to tell your guests riding in the car that one cup holder is for you and the other is for your remote...they will just have to hold their 128 oz. Super Ultra Chug drink.

Under your seat. This location is not ideal but is usable. When you need to adjust your SXRC simply 'tap' the brakes which will slide the unit forward onto your floor mat for easy access.

USING THE R-TOOL

The included R-Tools are used to remove the SXRC Control Head from the Trim Ring/Metal Cage assembly. The R-Tools simply slide into the notched area on both sides of the Plastic Cosmetic Trim Ring and will release the clips holding the SXRC Control Head.

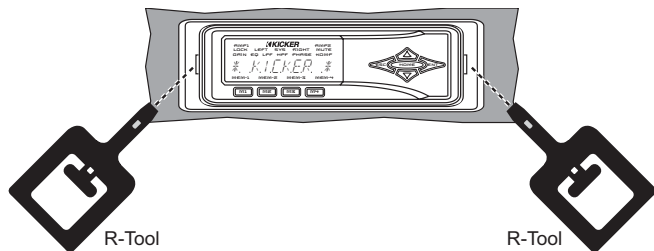

WIRING

Now that you have mounted your SXRC Control Head it is time to do some wiring. The first step is to plug your SXRC Control Head into the SXRC Interface Box.

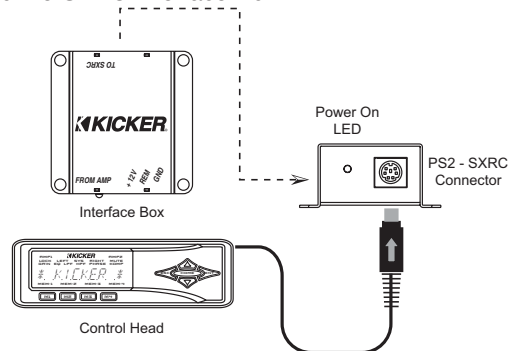

Next, run a fused (5 amp) constant 12 volt, ground and remote turn on to the SXRC Interface Box. Connect the wiring to the removable power plug by loosening the set screws, inserting the stripped wire and then tightening the set screw.

Strip Back Wire
1/4" (6 mm)

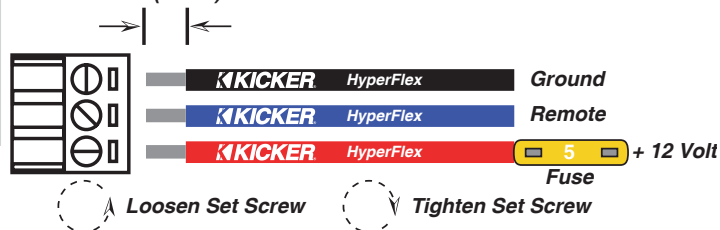

Now insert the removable power plug into the SXRC Interface Box.

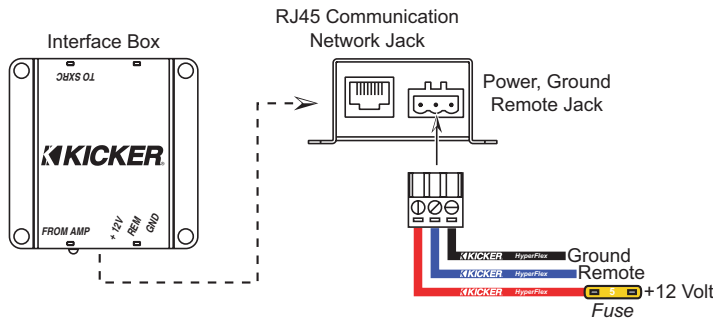

You should have something resembling this picture at this point. The Control Head plugged in and the power plug wired correctly and plugged in.

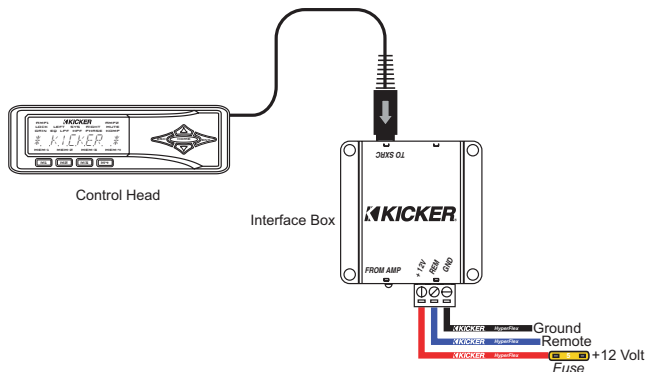

NOTE!!!

There are 8 pins in each RJ45 jack used on the SXRC Interface Box and on SX Series amplifiers. We only use 3 of these pins for the Digital Communications Network: Pins #2, #7 and #8.

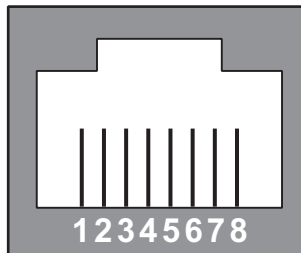

SX Amplifiers

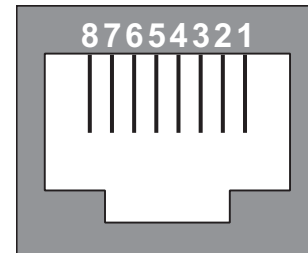

SXRC

If pins #2, #7 or #8 are bent or damaged, you will not be able to establish reliable communications on the SXRC Digital Communications Network.

A common issue is if your SX Series amplifier has been used with the Remote Bass Level Controller prior to being used with the SXRC. Some cables that came with the SX Series amplifiers for use with the Remote Bass level Controller will bend pins #1 and #8 down too far causing poor contact with the SXRC Communications Network Cable. To fix this simply take a small screwdriver or paper-clip and pull these pins back up into place.

Check all the RJ45 jacks on your amplifiers to insure the pins are up and in place before plugging in any of your SXRC Communications Network Cables.

Now we can run the Network Cables from the SXRC Interface Box to your SX Series amplifiers to create the SXRC Communications Network.

Run the supplied 5-meter Network Cable from the Interface Box to the REMOTE IN jack of your first SX Series amplifier.

Run the first supplied 1-meter Network Cable from the first SX Series amplifier's REMOTE OUT jack to the REMOTE IN jack of the second amplifier.

Run the second supplied 1-meter Network Cable from the second SX Series amplifier's REMOTE OUT jack to the REMOTE IN jack of the third amplifier.

You can continue adding amplifiers (16 total) by following this setup and supplying your own Network Cables.

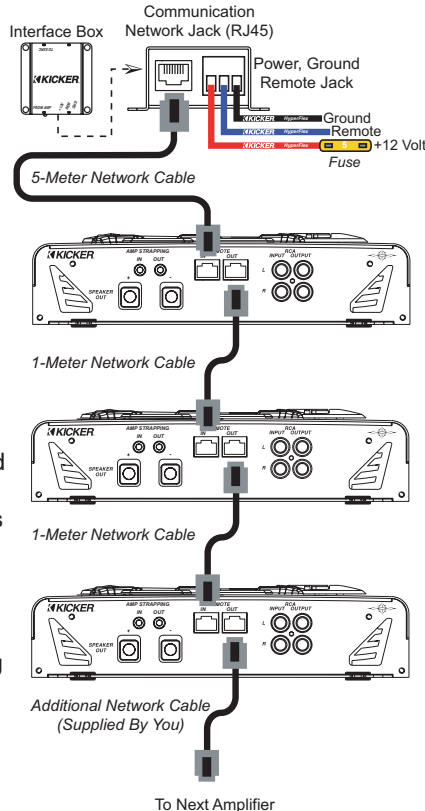

SXRC NETWORK CABLES

The SXRC is supplied with 3 Network Cables, one 5-meter and two 1-meter. This is enough to connect 3 SX Series amplifiers to the SXRC Interface Box. You can connect up to 16 SX Series amplifiers to the SXRC by supplying additional cables.

If you need additional cables or need to use custom lengths, you can purchase pre-made cables at any computer or electronics store. You want to purchase a Straight-Through, Ethernet Network Cable.

If you want to make your own custom length cables you will need:

- Bulk Cat3, Cat5, Cat5e or Cat6 network cable.
- Crimp on RJ45 plugs.
- Cable cutters.
- Electrician's scissors.
- RJ45 crimp tool.
- A UTP/Network Cable stripping tool.

Step 1.) Cut a piece of network cable the required length from the bulk cable roll using your Cable Cutters.

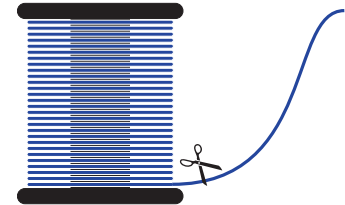

Step 2.) Using the UTP/Network Cable stripping tool, remove 1 inch (25 mm) of the outer insulating jacket from each end of the cable exposing the 8 wires (4 twisted pairs).

- | | |
|---------------|---------------|
| Pair 1 | Pair 2 |
| •Blue-White | •Green-White |
| •Blue | •Green |
| Pair 3 | Pair 4 |
| •Orange-White | •Brown-White |
| •Orange | •Brown |

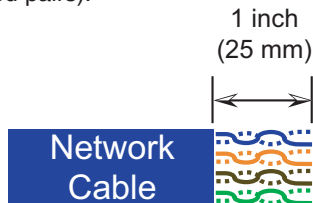

Step 3.) Untwist the 4 wire pairs on each end back to the outer insulating jacket and lay them in this order.

- Orange-White
- Orange
- Green-White
- Blue
- Blue-White
- Green
- Brown-White
- Brown



Step 4.) Hold the now grouped and sorted wires together tightly and using the Electrician's Scissors cut them all 1/2 inch (13 mm) in length at a 90 degree angle.

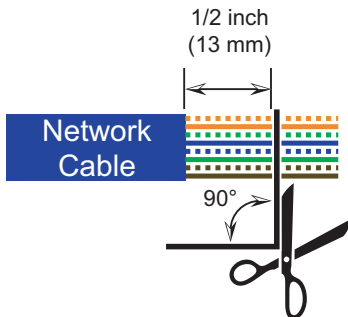

NOTE: The wires must be cut at a 90 degree angle to insure proper fit in the RJ45 plug.

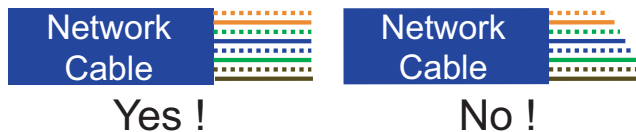

Step 5.) Slide an RJ45 plug (clip side down) onto the cable and seat it fully onto the cable. The 8 wires should butt up against the end of the plug tightly. Crimp the plug onto the wire securely using the RJ45 Crimp Tool. Repeat the process for the other end of the cable.

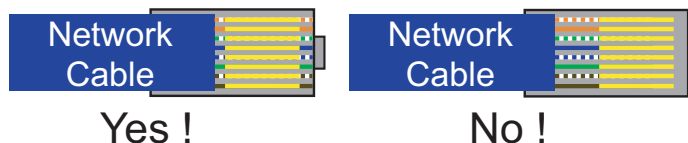

Step 6.) Lay the cable ends side by side (clip down) and verify the wire colors are in the correct order. The ends should be identical. If they are not, cut off the incorrect end and return to step 2 to put on a new RJ45 plug.

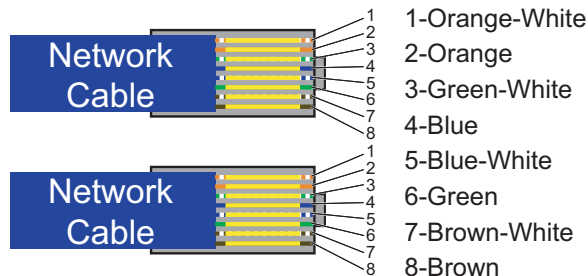

SOFTWARE UPDATES

Now that you have the SXRC mounted and wired properly it is time to update the software in all of your SX Series amplifiers. This process has to be completed for EACH amplifier and does require you to disconnect and reconnect cables between each step. Please read the instructions and follow them exactly as described.

You only have to do this setup and programming process one time for each amplifier.

Step 1.) Un-plug the Communications Network Cables from the REMOTE OUT jacks on ALL the SX Series amplifiers. Leave the Communications Network Cables connected to the REMOTE IN jacks. The SXRC Interface Box should only be connected to the first SX Series amplifier as the diagram to the right is showing.

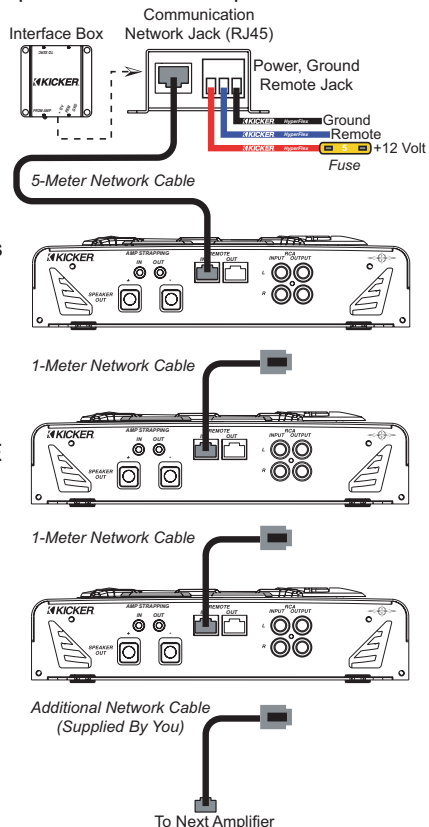

NOTE!!!

Each SX Series amplifier must be assigned its own unique address from the amplifier's keypad before it can be updated and controlled by the SXRC. *This has to be done at each amplifier's keypad and can not be done from the SXRC.* Think of the amplifiers like houses...no two houses can share the same street address...the mailman would throw a complete fit! Well, the SXRC feels the same way about two amps sharing the same Remote Communication Address.

Each series of SX amplifiers (.2-Stereo, .1-Mono Block, .4-Four Channel) has a unique address range that is not shared between the others. So it is impossible to accidentally share addresses from one series with another. All you need to do is assign a unique (different) address to each amplifier in your system. The possible choices for each series are:

- SX.2 Series** - Addresses 10-59
- SX.1 Series** - Addresses 60-109
- SX.4 Series** - Addresses 110-119

All SX Series amplifiers are shipped from the factory with their Remote Address set to the lowest setting.

- SX.2 Series** - Address 10
- SX.1 Series** - Address 60
- SX.4 Series** - Address 110

For example, lets say you have 4 SX.2, 4 SX.4 and 4 SX.1 amplifiers in your system for a grand total of 16 amplifiers. Set the Remote Addresses as such:

- | | | |
|---------------|---------------|----------------|
| SX.2 # 1 - 10 | SX.1 # 1 - 60 | SX.4 # 1 - 110 |
| SX.2 # 2 - 11 | SX.1 # 2 - 61 | SX.4 # 2 - 111 |
| SX.2 # 3 - 12 | SX.1 # 3 - 62 | SX.4 # 3 - 112 |
| SX.2 # 4 - 13 | SX.1 # 4 - 63 | SX.4 # 4 - 113 |

The important thing is that no matter what combination of amplifiers you are running, each amplifier must have its own unique Remote Address.

It is also a good idea to write down which amplifier has been assigned which address. This will help you later in identifying the amplifier and assigning it a name based on its function. For example: *BASS AMP 1, BASS AMP 2, FRONTSTAGE, MIDBASS,* etc. A fill-in-the-blank form is provided in the back of this manual to assist you.

Step 2.) Power up your system so you can access the settings and controls of your SX Series amplifiers. When the amplifiers power up you will see * *KICKER* *. You are now in the amplifiers Default Screen.

Step 3.) Press the **ENT** key to enter the Main Menu of the amplifier.



Step 4.) Press the **UP** or **DOWN** key until the display reads *SYSTEM*. Press the **ENT** key to enter the System Menu.



Step 5.) Press the **UP** or **DOWN** key until the display reads *REMOTE ADDR*. Press the **ENT** key to enter the Remote Address Selection Menu.



Step 6.) Press the **UP** or **DOWN** key to select the Remote Address you want to assign to this amplifier. Press the **ESC** key three times to save your setting and return to the Default Screen.



Step 7.) Repeat steps 3 through 6 for each amplifier.

Step 8.) Power cycle your system by turning it off, waiting 3 seconds, then turning it back on.

NOTE:

At this point each SX Series amplifier has been assigned a unique Remote Address. *Be sure you have properly done this to each amplifier before proceeding!* If multiple amplifiers share the same address, they all will be detected and you will corrupt the software that is loaded into each of the amplifiers. If this happens the SXRC display will flash *FAILED* and then show *MANUAL SW UPDATE REQUIRED*. You will then need to perform a Manual Software Update (*SW UPDATES* Menu) as described on page 73 in this manual for each amplifier.

If you need assistance please visit your local KICKER dealer or contact KICKER Technical Services.

Step 9.) The SXRC will display *STARTING* * while the amp(s) and remote are booting. When completed booting it will switch to * *KICKER* *. You are now in the Default Menu.



Step 10.) Press the **ENT** key one time to enter the SXRC Main Menu. The first Main Menu item will be displayed which is *AMP ADJ*.



Step 11.) Press the **UP** or **DOWN** key until the display reads *SXRC SETUP*. Press the **ENT** key to enter the *SXRC SETUP* Menu.



Step 12.) Press the **UP** or **DOWN** key until the display reads *AUTOSEARCH*. Press the **ENT** key to activate the *AUTOSEARCH* function.



EXTREMELY IMPORTANT NOTE:

DO NOT power down your system or amplifiers during this process (Step 13, A-P). Doing so will corrupt the software and force you to perform a Manual Software Update!

Step 13.) The SXRC is now:

A.) Searching for the first amplifier connected to the Communications Network.

B.) Detecting the amplifier's software boot loader.

C.) Erasing the old software.

D.) Loading the new software into the amplifier.

E.) Checking the software in the amplifier to insure it has been loaded correctly.

F.) Confirming the software update is successful.

G.) Loading the amplifier into the SXRC.

H.) Displaying how many amplifiers have been detected (1 at this point), successfully updated and brought into the SXRC Communications Network.

A KICKER AMP1 LOCK LEFT SYS RIGHT MUTE GAIN EQ LFF HFF PHASE KOMP AMP2 LOCK LEFT SYS RIGHT MUTE GAIN EQ LFF HFF PHASE KOMP
SEARCH *
MEM-1 MEM-2 MEM-3 MEM-4

A KICKER AMP1 LOCK LEFT SYS RIGHT MUTE GAIN EQ LFF HFF PHASE KOMP AMP2 LOCK LEFT SYS RIGHT MUTE GAIN EQ LFF HFF PHASE KOMP
DETECT LDR
MEM-1 MEM-2 MEM-3 MEM-4

A KICKER AMP1 LOCK LEFT SYS RIGHT MUTE GAIN EQ LFF HFF PHASE KOMP AMP2 LOCK LEFT SYS RIGHT MUTE GAIN EQ LFF HFF PHASE KOMP
ERASING *
MEM-1 MEM-2 MEM-3 MEM-4

A KICKER AMP1 LOCK LEFT SYS RIGHT MUTE GAIN EQ LFF HFF PHASE KOMP AMP2 LOCK LEFT SYS RIGHT MUTE GAIN EQ LFF HFF PHASE KOMP
PROGRAM=00
MEM-1 MEM-2 MEM-3 MEM-4

A KICKER AMP1 LOCK LEFT SYS RIGHT MUTE GAIN EQ LFF HFF PHASE KOMP AMP2 LOCK LEFT SYS RIGHT MUTE GAIN EQ LFF HFF PHASE KOMP
VERIFY =00
MEM-1 MEM-2 MEM-3 MEM-4

A KICKER AMP1 LOCK LEFT SYS RIGHT MUTE GAIN EQ LFF HFF PHASE KOMP AMP2 LOCK LEFT SYS RIGHT MUTE GAIN EQ LFF HFF PHASE KOMP
VERIFY OK
MEM-1 MEM-2 MEM-3 MEM-4

A KICKER AMP1 LOCK LEFT SYS RIGHT MUTE GAIN EQ LFF HFF PHASE KOMP AMP2 LOCK LEFT SYS RIGHT MUTE GAIN EQ LFF HFF PHASE KOMP
LOADING *
MEM-1 MEM-2 MEM-3 MEM-4

A KICKER AMP1 LOCK LEFT SYS RIGHT MUTE GAIN EQ LFF HFF PHASE KOMP AMP2 LOCK LEFT SYS RIGHT MUTE GAIN EQ LFF HFF PHASE KOMP
1 UNITS
MEM-1 MEM-2 MEM-3 MEM-4

The SXRC will now ask you if you want to save the current settings of your amplifier into a memory preset. Use the **UP** or **DOWN** keys to select:

I.) SAVE -- YES

J.) SAVE -- NO

and press the **ENT** key to select.

If you select *SAVE -- NO* then the amplifier's current settings are not stored into the SXRC.

If you select *SAVE -- YES* then you choose which Global Memory Location to store the amplifier's settings in by using the **UP** or **DOWN** key to scroll through the options (**K**, **L**, **M**, **N**). When the memory you want to use is selected press the **ENT** key to store. The SXRC will respond by blinking *STORED* (**O**) to confirm the memory storing has completed successfully.

The display will then read *AUTOSEARCH* (**P**) which indicates the software update process has completed and the SXRC is ready to find and update another SX Series amplifier.

All of the above steps happen automatically once you initiate the *AUTOSEARCH* function.

A KICKER AMP1 LOCK LEFT SYS RIGHT MUTE GAIN EQ LFF HFF PHASE KOMP AMP2 LOCK LEFT SYS RIGHT MUTE GAIN EQ LFF HFF PHASE KOMP
SAVE -- YES
MEM-1 MEM-2 MEM-3 MEM-4

A KICKER AMP1 LOCK LEFT SYS RIGHT MUTE GAIN EQ LFF HFF PHASE KOMP AMP2 LOCK LEFT SYS RIGHT MUTE GAIN EQ LFF HFF PHASE KOMP
SAVE -- NO
MEM-1 MEM-2 MEM-3 MEM-4

A KICKER AMP1 LOCK LEFT SYS RIGHT MUTE GAIN EQ LFF HFF PHASE KOMP AMP2 LOCK LEFT SYS RIGHT MUTE GAIN EQ LFF HFF PHASE KOMP
MEMORY--1
MEM-1 MEM-2 MEM-3 MEM-4

A KICKER AMP1 LOCK LEFT SYS RIGHT MUTE GAIN EQ LFF HFF PHASE KOMP AMP2 LOCK LEFT SYS RIGHT MUTE GAIN EQ LFF HFF PHASE KOMP
MEMORY--2
MEM-1 MEM-2 MEM-3 MEM-4

A KICKER AMP1 LOCK LEFT SYS RIGHT MUTE GAIN EQ LFF HFF PHASE KOMP AMP2 LOCK LEFT SYS RIGHT MUTE GAIN EQ LFF HFF PHASE KOMP
MEMORY--3
MEM-1 MEM-2 MEM-3 MEM-4

A KICKER AMP1 LOCK LEFT SYS RIGHT MUTE GAIN EQ LFF HFF PHASE KOMP AMP2 LOCK LEFT SYS RIGHT MUTE GAIN EQ LFF HFF PHASE KOMP
MEMORY--4
MEM-1 MEM-2 MEM-3 MEM-4

A KICKER AMP1 LOCK LEFT SYS RIGHT MUTE GAIN EQ LFF HFF PHASE KOMP AMP2 LOCK LEFT SYS RIGHT MUTE GAIN EQ LFF HFF PHASE KOMP
STORED
MEM-1 MEM-2 MEM-3 MEM-4

A KICKER AMP1 LOCK LEFT SYS RIGHT MUTE GAIN EQ LFF HFF PHASE KOMP AMP2 LOCK LEFT SYS RIGHT MUTE GAIN EQ LFF HFF PHASE KOMP
AUTOSEARCH
MEM-1 MEM-2 MEM-3 MEM-4

NOTE:

If steps 8-13 worked correctly, you have taken the first step to remote control bliss, skip to step 14. If not, then read on.

If the display came back blinking *0 UNITS* after doing the *AUTOSEARCH* then there is a problem with the Communications Network.

- Go back and double check your Communications Network cable and make sure it is inserted properly and 'snapped' into place.
- If you have purchased different cables, double check that they are Straight-Through Ethernet Network cables.
- If you have made your own cables double check them for secure and proper termination.
- Did you check the pins (#1 and #8) in the SX Series amplifiers to make sure they are not bent or damaged?

You have to get the Communications Network working with the first amplifier and update its software before we can proceed with the rest of the amplifiers so double check everything. Try a different cable if necessary. Repeat steps 8-13 after double checking your cable and jacks. Once the first amp is successfully updated and in the SXRC Communications Network you can move on to step 14.

If you can not get the amplifier to accept a software update then visit your local KICKER dealer or call KICKER Technical Services for more troubleshooting advice.

Step 14.) If you are only controlling one SX Series amplifier with the SXRC (*yeah...right...we bet you have at least two!*) you can skip to the next section in the manual titled Operation (look for the gray box tabs on the side of the pages...in case you missed that up to now). If you have more than one SX Series amplifier to control then continue with Step 15.

Step 15.) Plug the Communications Network Cable from the REMOTE IN jack on the second amplifier into the REMOTE OUT jack of the first amplifier in the chain. Even if you have more than two amps, at this point only the first and second one should be connected as the diagram on the right shows.

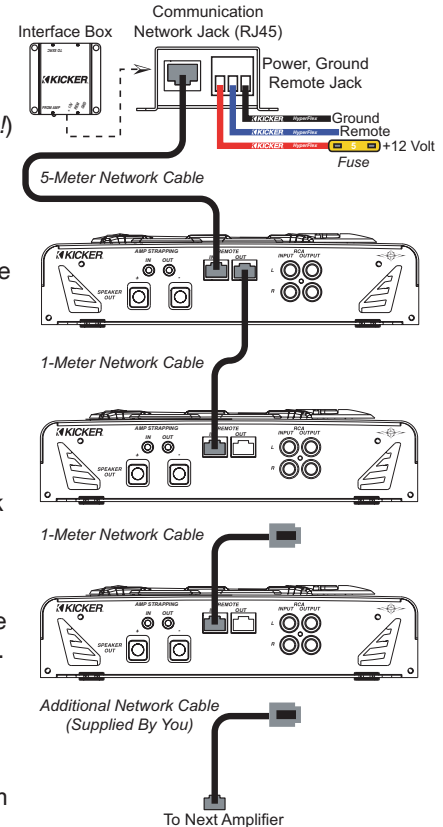

NOTE: If you take longer than three minutes to plug the Network Cable in from the second amplifier (Step 15) the SXRC will time out and return to the scrolling Default Menu. If this happens you will then need to skip Step 16 and return to the Autosearch Menu by following Steps 17-19.

Step 16.) If the ISIS Display is showing *AUTOSEARCH* press the **ENT** key to detect, update and load the second amplifier. **Skip to Step 20.**



Step 17.) Press the **ENT** key one time to enter the SXRC Main Menu. The first Main Menu item will be displayed which is *AMP ADJ.*



Step 18.) Press the **UP** or **DOWN** key until the display reads *SXRC SETUP*. Press the **ENT** key to enter the *SXRC SETUP* Menu.



Step 19.) Press the **UP** or **DOWN** key until the display reads *AUTOSEARCH*. Press the **ENT** key to activate the *AUTOSEARCH* function.



Step 20.) The SXRC is now searching for the second amplifier connected to the Communications Network. It will do the exact same sequence (A-P) as in step 13. Once it detects the amplifier it will load the new software into the amplifier and verify the software upload has been successful. The remote will then display how many amplifiers have been detected (2 at this point), successfully updated and brought into the SXRC Communications Network.



Like before, the SXRC will ask if you want to save the current settings of your second amplifier into a memory preset. Use the **UP** or **DOWN** keys to select *SAVE - YES* or *SAVE - NO* and press the **ENT** key to select.



If you select *SAVE - NO* then the amplifier's current settings are not stored into the SXRC.

NOTE:

The memory settings in the SXRC are a global memory system. What this means is that each memory preset (1-4) stores the settings of all (up to 16) the amplifiers connected to it. This allows you to have unique settings for each amplifier stored and ready for instant recall. If you chose *MEMORY-1* before, you can choose it again. All amplifiers will have their individual settings stored here in memory location 1 for instant recall later.

If you select *SAVE - YES* then you choose which Global Memory Location to store the amplifier's settings in by using the **UP** or **DOWN** key to scroll through the options (*MEMORY-1* through *MEMORY-4*). When the memory you want to use is selected press the **ENT** key to store. The SXRC will respond by blinking *STORED* to confirm the memory storing has completed successfully.



The display will then read *AUTOSEARCH* which indicates the software update process has completed.

NOTE:

If steps 15-20 worked correctly, you should now have two SX Series amplifiers updated and brought into the SXRC Communications Network, skip to step 21. If not, then read on.

If the display came back blinking *1 UNITS* after doing the *AUTOSEARCH* then there is a problem with the Communications Network.

- Go back and double check your Communications Network cable between the first and second amplifier and make sure it is inserted properly and 'snapped' into place.
- If you have purchased different cables, double check that they are Straight-Through Ethernet Network cables.
- If you have made your own cables double check them for secure and proper termination.
- Did you check the pins (#1 and #8) in the SX Series amplifiers to make sure they are not bent or damaged?

You have to get the Communications Network working with the second amplifier and update its software before we can proceed with the rest of the amplifiers so double check everything. Try a different cable if necessary. Repeat steps 15-20 after double checking your cables and jacks. Once the second amp is successfully updated and in the Communications Network you can move on to step 21.

Step 21.) If you are only controlling only two SX Series amplifiers with the SXRC (*sure ...sure ... we know you have them stacked up!*) you can skip to the next section in the manual titled Operation.

If you have more than two SX Series amplifiers to control then continue with Step 23.

Step 22.) Plug the Communications Network Cable from the REMOTE IN jack on the third amplifier into the REMOTE OUT jack of the second amplifier in the chain. Even if you have more than three amps, at this point only the first, second and third ones should be connected as the diagram on the right shows.

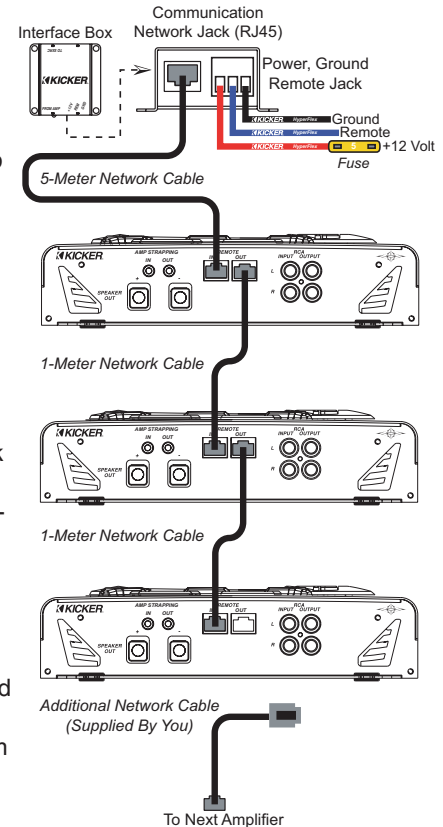

NOTE: If you take longer than three minutes to plug the Network Cable in from the third amplifier (Step 22) the SXRC will time out and return to the scrolling Default Menu. If this happens you will then need to skip Step 23 and return to the Autosearch Menu by following Steps 24-26.

Step 23.) If the ISIS Display is showing *AUTOSEARCH* press the **ENT** key to detect, update and load the second amplifier. **Skip to Step 27.**



Step 24.) Press the **ENT** key one time to enter the SXRC Main Menu. The first Main Menu item will be displayed which is *AMP ADJ.*



Step 25.) Press the **UP** or **DOWN** key until the display reads *SXRC SETUP*. Press the **ENT** key to enter the *SXRC SETUP* Menu.



Step 26.) Press the **UP** or **DOWN** key until the display reads *AUTOSEARCH*. Press the **ENT** key to activate the *AUTOSEARCH* function.



Step 27.) The SXRC is now searching for the third amplifier connected to the Communications Network. It will do the exact same sequence (A-P) as in step 13. Once it detects the amplifier it will load the new software into the amplifier and verify the software upload has been successful. The remote will then display how many amplifiers have been detected (3 at this point), successfully updated and brought into the SXRC Communications Network.



Like before, the SXRC will ask if you want to save the current settings of your third amplifier into a memory preset. Use the **UP** or **DOWN** keys to select *SAVE - YES* or *SAVE - NO* and press the **ENT** key to select.



If you select *SAVE - NO* then the amplifier's current settings are not stored into the SXRC.

NOTE:

Remember, the memory settings in the SXRC are a global memory system. What this means is that each memory preset (1-4) stores the settings of all (up to 16) the amplifiers connected to it. This allows you to have unique settings for each amplifier stored and ready for instant recall. If you chose *MEMORY-1* before, you can choose it again. All amplifiers will have their individual settings stored here in memory location 1 for instant recall later.

If you select *SAVE - YES* then you choose which Global Memory Location to store the amplifier's settings in by using the **UP** or **DOWN** key to scroll through the options (*MEMORY-1* through *MEMORY-4*). When the memory you want to use is selected press the **ENT** key to store. The SXRC will respond by blinking *STORED* to confirm the memory storing has completed successfully.



The display will then read *AUTOSEARCH* which indicates the software update process has completed.

NOTE:

If steps 21-27 worked correctly, you should now have three SX Series amplifiers updated and brought into the SXRC Communications Network, skip to step 30. If not, then read on.

If the display came back blinking *2 UNITS* after doing the *AUTOSEARCH* then there is a problem with the Communications Network.

- Go back and double check your Communication Network cable between the second and third amplifier and make sure it is inserted properly and 'snapped' into place.
- If you have purchased different cables, double check that they are Straight-Through Ethernet Network cables.
- If you have made your own cables double check them for secure and proper termination.
- Did you check the pins (#1 and #8) in the SX Series amplifiers to make sure they are not bent or damaged?

You have to get the Communications Network working with the third amplifier and update its software before we can proceed with the rest of the amplifiers so double check everything. Try a different cable if necessary. Repeat steps 21-27 after double checking your cables and jacks. Once the third amp is successfully updated and in the Communications Network you can move on to step 28.

Step 28.) If you are only controlling only three SX Series amplifiers with the SXRC (*Only 3? You probably have three just on bass duty!*) you can skip to the next section in the manual titled Operation. If you have more than three SX Series amplifiers to control then continue with Step 29.

Step 29.) Plug the Communications Network Cable from the REMOTE IN jack on the fourth amplifier into the REMOTE OUT jack of the third amplifier in the chain. Even if you have more than four amps, at this point only the first, second, third and fourth ones should be connected as the diagram on the right shows.

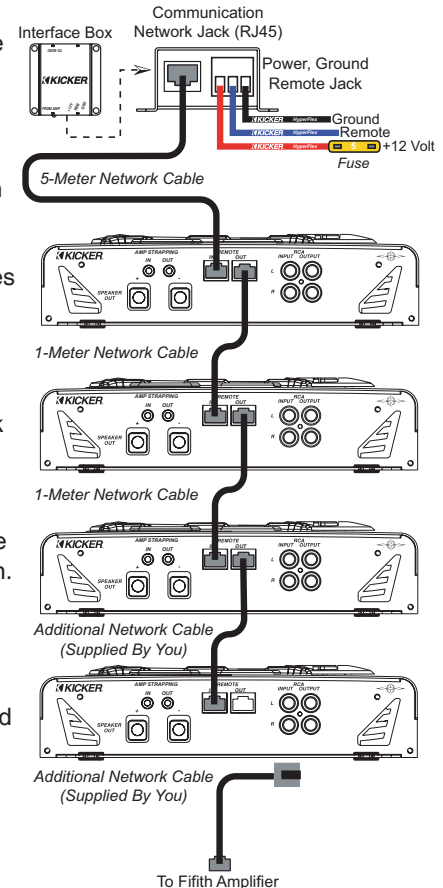

NOTE: If you take longer than three minutes to plug the Network Cable in from the fourth amplifier (Step 29) the SXRC will time out and return to the scrolling Default Menu. If this happens you will then need to skip Step 30 and return to the Autosearch Menu by following Steps 31-33.

Step 30.) If the ISIS Display is showing *AUTOSEARCH* press the **ENT** key to detect, update and load the second amplifier. **Skip to Step 34.**



Step 31.) Press the **ENT** key one time to enter the SXRC Main Menu. The first Main Menu item will be displayed which is *AMP ADJ.*



Step 32.) Press the **UP** or **DOWN** key until the display reads *SXRC SETUP*. Press the **ENT** key to enter the *SXRC SETUP* Menu.



Step 33.) Press the **UP** or **DOWN** key until the display reads *AUTOSEARCH*. Press the **ENT** key to activate the *AUTOSEARCH* function.



Step 34.) The SXRC is now searching for the fourth amplifier connected to the Communications Network. It will do the exact same sequence (A-P) as in step 13. Once it detects the amplifier it will load the new software into the amplifier and verify the software upload has been successful. The remote will then display how many amplifiers have been detected (4 at this point), successfully updated and brought into the SXRC Communications Network.



NOTE:

If steps 28-34 worked correctly, you should now have four SX Series amplifiers updated and brought into the SXRC Communications Network, skip to step 35. If not, then read on.

If the display came back blinking *3 UNITS* after doing the *AUTOSEARCH* then there is a problem with the Communications Network.

- Go back and double check your Communication Network cable between the third and fourth amplifier and make sure it is inserted properly and 'snapped' into place.
- If you have purchased different cables, double check that they are Straight-Through Ethernet Network cables.
- If you have made your own cables double check them for secure and proper termination.
- Did you check the pins (#1 and #8) in the SX Series amplifiers to make sure they are not bent or damaged?

You have to get the Communications Network working with the fourth amplifier and update its software before we can proceed with any additional amplifiers so double check everything. Try a different cable if necessary. Repeat steps 28-34 after double checking your cables and jacks. Once the fourth amp is successfully updated and in the Communications Network you can move on to step 35.

Step 35.) If you are controlling just four SX Series amplifiers with the SXRC (*A nice start...you can always add more...up to a total of 16*) you can skip to the next section in the manual titled Operation. If you have more than four SX Series amplifiers to control then continue with Step 36.

Step 36.) At this point the manual has walked you through the process, step-by-step, on how to install, update and troubleshoot the connection of four SX Series amplifiers to the SXRC. If you are controlling more than four SX Series amplifiers (*which we hope you are!*) simply follow the same steps above (29-34) for each additional amplifier. The process is exactly the same. Just remember that you cannot add another amplifier until you get the current one recognized, updated and brought into the SXRC Communications Network.

The entire process is very easy, even though there seems to be quite a few steps. Once the SXRC detects a new amplifier on the SXRC Communications Network through the *AUTOSearch* function it takes approximately 90 seconds to load and verify the new software. So if you have 16 amplifiers, the entire process will take approximately 25-30 minutes. Remember, this only has to be done once.

If you need any further assistance with these steps please visit your local KICKER dealer or contact KICKER Technical Services for more guidance.

After you have connected all of your SX Series amplifiers and updated the software, you can move on to the Operation section of this manual to learn all the features, functions and operation of your SXRC Remote Control.

Here is a block diagram showing 16 SX Series amplifiers connected to the SXRC. Looks good doesn't it? Go get a napkin...we can see the drool on your chin from here in Stillwater, Oklahoma.

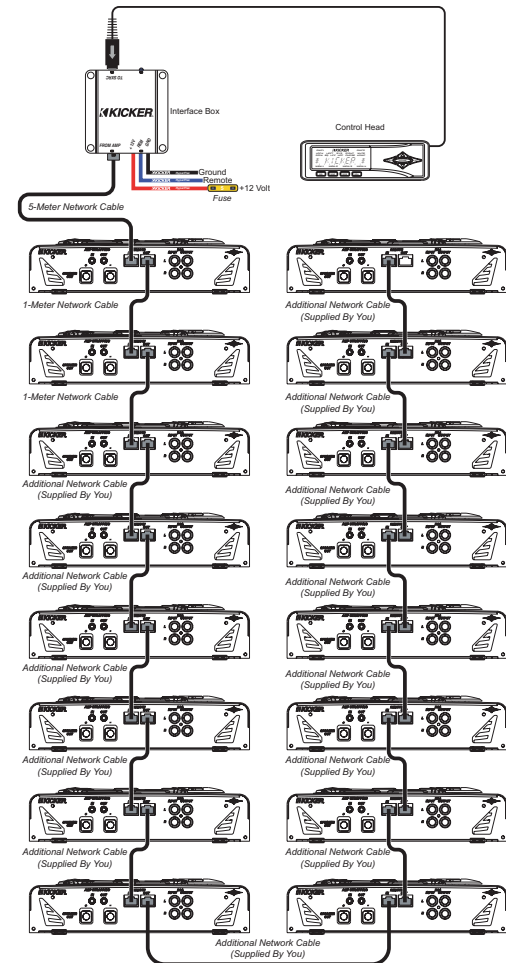

NAVIGATION

Your KICKER SXRC uses the latest in microprocessor technology control to provide you with operational information about your amplifiers, full control over amplifier settings, real-time diagnostics, global memory presets and amplifier group control capability. All of this from the driver's seat of your car using a very simple multi-level menu-driven operating system.

The menu system is designed in layers. There is a starting point and you simply keep drilling down until you get to the menu item you want to view or change. This menu tree gives you an example of how the SXRC menu structure is set up.



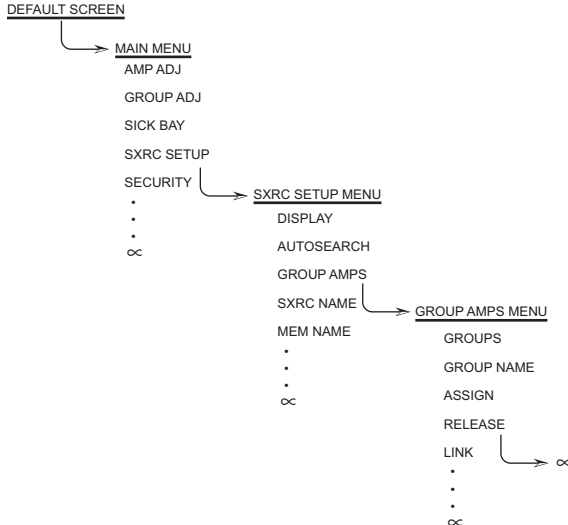

NOTE: Not all menus and menu items shown.



As you can see there can be an infinite number of menu levels and each of these menu levels can have an infinite number of its own items.

Navigating the menu structure is very easy using the 5-way keypad.



You use the **UP**  and **DOWN**  keys to scroll through the available menu items. The **ENT**  key is used to select that menu item. The **ESC**  key backs you up one menu level from where you are, and the **HOME**  key can return you all the way to MAIN MENU by pressing and holding it for 1.5 seconds.

For example let's begin at the DEFAULT SCREEN; our goal is to get to the RELEASE menu item. Pressing the **ENT** key would get us to MAIN MENU. Now use the **UP** or **DOWN** keys to scroll to *SXRC SETUP*, and then press the **ENT** key. Now you are in the SXRC SETUP MENU. Using the **UP** or **DOWN** keys again you scroll to *GROUP AMPS* and press the **ENT** key. You are now in the GROUP AMPS MENU. Use the **UP** or **DOWN** keys again to scroll to *RELEASE* and then press the **ENT** key. That's it! You are there.

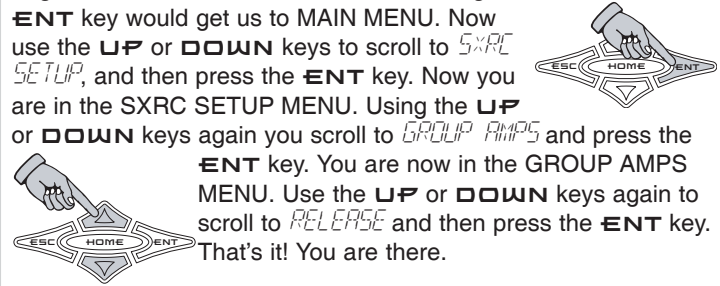

This is how you view information and change settings in your SXRC Remote Control.

Continuing our example, we are now in the **RELEASE** item in the **GROUP AMPS MENU**. If we press the **ESC** key we would go back up to the **GROUP AMPS MENU**. If we press the **ESC** key again we would go to the **SXRC SETUP MENU**. One more press of the **ESC** key and we are in the **MAIN MENU**.



Let's start at the **RELEASE** item in the **GROUP AMPS MENU** again but instead press and hold the **HOME** key for 1.5 seconds. Doing this will take us all the way back to the **MAIN MENU** in one key press. Pressing and holding the **HOME** key **ITEM** you started with in the **MAIN MENU**, no matter how deep in the menu level structure you are. Pretty cool!



This is a very quick way to return to the **MAIN MENU** after drilling down several menu layers to view or change an item.

When adjusting any **SXRC** control the **UP** and **DOWN** arrow keys have 2 speeds, normal and accelerated.

Pressing and releasing the key repeatedly will scroll through the menu items at normal speed.



Pressing the key and holding it in for longer than 1.5 seconds will activate the accelerated scrolling mode and scroll through the menu items at a much faster rate. Releasing the key will return it to normal speed mode.



Menu System

Here are the descriptions of each menu item, its function and how to operate it.

DEFAULT - This menu is displayed when your **SXRC** is first powered up and operating. If you are in another menu making adjustments, the **SXRC** will time-out and return to the **DEFAULT** menu automatically after 3 minutes of no key press activity.

The following information is scrolled through the **ISIS** display one after the other and repeats.

- » * **KICKER** * - Your friend wants to know who makes that wicked sick remote sitting in your dash...we put it right here for you! Plus...it is quicker than a Google™ search!
- » **--SXRC--** - The name of the remote control. You can change this name to whatever you like. See the **SXRC SETUP** section of the manual.
- » **XX X VOLTS** - Displays the current voltage at the selected amplifier's (**INFO AMP**) + 12 volt battery terminal. Selecting the **INFO AMP** is described in the **SXRC SETUP** section of the manual.
- » **XX X DEG F** or **XX X DEG C** - Displays the current temperature of the selected amplifier (**INFO AMP**) in fahrenheit or celsius. Selecting the **INFO AMP** is described in the **SXRC SETUP** section of the manual.

- » *MEMORY NAME* - The name of the current Global Memory Preset in use, if any are currently selected.
- » *VOL = 00 0 00* - The current setting of the Digital Remote Volume Control. You can select which amplifiers are controlled by this function. See the SXRC SETUP section of the manual.
- » *XX UNITS* - How many SX Series amplifiers are currently connected to the SXRC. If you have 4 but it only says 3...time to troubleshoot...or go fishing. Your choice.
- » *DATE DISPLAY* - Displays the current date in month-day-year format. Requires initial setup by you and then is kept up-to-date with internal backup battery. Described later in the SXRC SETUP section of the manual.
- » *TIME DISPLAY* - Displays the current time in 12 hour am/pm format. Requires initial setup by you and then is kept up-to-date with internal backup battery. Described later in the SXRC SETUP section of the manual.

You can freeze the scrolling display on any item in the DEFAULT menu by simply pressing the **HOME** key.



Once you freeze the scrolling display you can manually select any item to view by pressing the **ESC** key. Each press brings up the next item in the DEFAULT menu.

If you want the display to start scrolling again, simply press the **HOME** key.



You can change the Digital Remote Volume Control (DRVC) at any time when you are in the DEFAULT menu. Simply press the **UP** key to increase the volume level or press the **DOWN** key to decrease the volume level.

When you press either the **UP** or **DOWN** key to change the DRVC level, the display will instantly show the current Remote Volume Level.



The Digital Remote Volume Control has an operating range of 0.0 dB to -30.0 dB. Each press of the **UP** key will increase the DRVC level .5 dB and each press of the **DOWN** key decreases the DRVC level .5 dB.



PRESS & HOLD

Pressing and holding either the **UP** or **DOWN** key will cause the DRVC level to change rapidly.

The SXRC will pause on the DRVC level for 2 seconds after you have made your adjustment and then return to the previous DEFAULT menu item that was being displayed before you adjusted the DRVC.

MAIN

This is the first menu you access from the DEFAULT menu and is the gateway to all the settings and information display on your SXRC.

To enter the MAIN menu simply press the **ENT** key while in the DEFAULT menu.



The available selections in the MAIN menu are:

- » AMP ADJ
- » GROUP ADJ
- » SICK BAY
- » SXRC SETUP
- » SECURITY

Use the **UP** and **DOWN** arrow keys to scroll through the available selections in the MAIN menu.



When you have the menu item selected that you want to view or adjust simply press the **ENT** key to select it.



AMP ADJ

AMP ADJ MENU - This menu item lets you select each individual amplifier connected to the SXRC and view or adjust any of its settings.



Once you select the **AMP ADJ** menu a list of all the amplifiers connected to the SXRC will be available. The list will show the current name of the SX Series amplifier. This will either be the default name from the factory (example *SX-500/2*) or any name you may have assigned to the amp.



Use the **UP** and **DOWN** keys to scroll through the list of available amplifiers. If you have several of the same model of amplifier installed and did not change the name prior to installing the SXRC then you will see the same name when you press the **UP** or **DOWN** keys on the SXRC. In other words it appears like nothing changed. It did...just read on.

To help you identify which amp you are currently viewing simply press and hold the **ENT** key and the Remote Address of the amplifier will be displayed. This will aid you in determining which amp you are currently viewing when you have multiple amps of the same make.



Changing the amplifiers name (coming up later in the manual) will help you here. Remember when we said to keep track of which amp had what unique Remote Address? It all makes sense now.



Once you have found the amplifier you wish to adjust simply press the **ENT** key to select it.

Once the amplifier you want to adjust is selected you will be able to choose from the following items. Some of these functions may not be available depending on if the amplifier is assigned to a Group and what LINK property the group has set. This is described in more detail in the SXRC SETUP menu.

| | |
|-----------|--------------|
| » GAIN | » KOMPRESSOR |
| » EQ | » KOMP ADJ |
| » LO-PASS | » GAIN RANGE |
| » HI-PASS | » BYPASS DSP |
| » PHASE | » PINK NOISE |
| » MUTE | » REMOTE VOL |

Use the **UP** and **DOWN** keys to scroll through the selections above and press the **ENT** key to select.



GAIN MENU - Here is where you adjust the selected amplifier's gain controls. The SX Series amplifiers' UltraMatch™ gain structure features both a digital input gain attenuator with five selectable Gain Ranges AND 12dB of "tweakable" Gain adjustment in each range! This super wide adjustment range allows SX amplifiers to operate flawlessly with any source unit, pre-amplifier, or line driver.

In "Gear-Head" terms, the Gain Range and Gain adjustments can be compared to the gear box and gas pedal of a race car. The Gain Range represents what gear you're in and the Gain represents stepping on the gas. In this menu, you are adjusting the gas pedal! The gear box comes up later.

Use the **UP** and **DOWN** keys to scroll through *LEFT CHN*, *RIGHT CHN* or *BOTH CHNS* and then press the **ENT** key to select. *SX.1 Series do not have Left or Right channel options since it is a Mono-Block design. Skip this step and move to next paragraph.*



Now use the **UP** and **DOWN** keys to increase or decrease the gain of the selected channel(s) in .5 dB increments from 0 dB to +12 dB. (0 0 to 12 0)



Press the **ESC** key to save your adjustment and return to the *LEFT CHN*, *RIGHT CHN*, *BOTH CHNS* options menu. You can now select another channel to adjust on this amplifier if desired. Does not apply to SX.1 Series. Pressing the ESC key at this point on a SX.1 Series amplifier exits the GAIN menu.



When you are done adjusting the gain on this amplifier press the **ESC** key while in the *LEFT CHN*, *RIGHT CHN*, *BOTH CHNS* options menu to return to the AMP ADJ menu and choose another function to adjust.



NOTE:

While you are in the GAIN menu the *GAIN* indicator on the ISIS VFD display is lit. This indicates you are making adjustments in the GAIN menu.



The *LEFT* and *RIGHT* indicators will light up as well to indicate which amplifier channel(s) you are currently adjusting.



EQ MENU - Here is where you adjust the selected amplifier's single band parametric equalizer.

Use the **UP** and **DOWN** keys to scroll through *FREQUENCY*, *BOOST/CUT* and *BANDWIDTH* and then press the **ENT** key to select.



FREQUENCY selects the center frequency of the equalizer and can be set at any 1/12th octave spaced frequency from 20 Hz - 20 kHz. (20 Hz to 20325 Hz) *SX.1 Series is 10 Hz to 200 Hz in 1 Hz Steps.*

Use the **UP** and **DOWN** keys to select your frequency. Press the **ESC** key to save your setting and return to the *FREQUENCY*, *BOOST/CUT*, *BANDWIDTH* options menu. You can now select another equalizer option to adjust on this amplifier if desired.



BANDWIDTH (better known as Q) can be set from .5 to 10 in .5 increments. In simple terms, lower Q effects more frequencies around the center frequency while higher Q effects fewer frequencies around the center frequency.

As an example, if our center frequency is 100 Hz, a Q of .5 (area in gray) effects many more frequencies around 100 Hz than a Q of 10 (area in black). There is no right or wrong Q, you use whatever fits the needs of the system or personal taste. KICKER uses a default Q of 3.

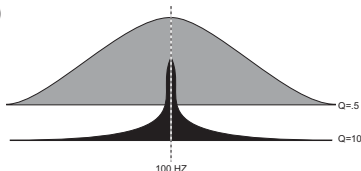

Use the **UP** and **DOWN** keys to select your bandwidth (Q) value and press the **ESC** to save your setting and return to the *FREQUENCY*, *BOOST/CUT*, *BANDWIDTH* options menu. You can now select another equalizer option to adjust on this amplifier if desired.



BOOST/CUT is where you boost or cut the equalizer and has a range of 36 dB; -18 dB to +18 dB in .5 dB steps. Keep in mind that for every 3 dB of boost you are requiring the amplifier to use twice as much power in that equalized area. The default setting from KICKER is *FLAT* (No boost or cut).

Use the **UP** and **DOWN** keys to adjust your boost or cut and press the **ESC** key to save your setting and return to the *FREQUENCY*, *BOOST/CUT*, *BANDWIDTH* options menu. You can now select another equalizer option to adjust on this amplifier if desired.



When you are done adjusting the equalizer on this amplifier press the **ESC** key while in the *FREQUENCY*, *BOOST/CUT*, *BANDWIDTH* options menu to return to the AMP ADJ menu and choose another function to adjust.



NOTE:

While you are in the EQ menu the *EQ* indicator on the ISIS display is lit. This indicates you are making adjustments in the EQ menu.



LO-PASS MENU - Here is where you adjust the selected amplifier's low pass crossover.

Use the **UP** and **DOWN** keys to scroll through *FREQUENCY* and *SLOPE* and then press the **ENT** key to select.



FREQUENCY selects the crossover point and can be set at any 1/12th octave spaced frequency from 30 Hz to 20 kHz. (30 Hz to 20325 Hz) *SX.1 Series is 30 Hz to 200 Hz in 1 Hz steps.*

Use the **UP** and **DOWN** keys to select your frequency. Press the **ESC** key to save your setting and return to the *FREQUENCY* and *SLOPE* options menu. You can now select another low pass crossover option to adjust on this amplifier if desired.



SLOPE selects the roll-off of the crossover and can be set from *OFF* to *36 DB/OCT* in 6 dB steps. *SX.1 Series is OFF to 48 dB in 6 dB Steps.*

Use the **UP** and **DOWN** keys to select your low pass crossover slope. Press the **ESC** key to save your setting and return to the *FREQUENCY* and *SLOPE* options menu. You can now select another low pass crossover option to adjust on this amplifier if desired.



When you are done adjusting the low pass crossover on this amplifier press the **ESC** key while in the *FREQUENCY* and *SLOPE* options menu to return to the AMP ADJ menu and choose another function to adjust.



NOTE:

While you are in the LO-PASS menu the *LPF* indicator on the ISIS display is lit. This indicates you are making adjustments in the LO-PASS menu.



The KICKER SXRC monitors and prevents any low pass crossover point from being set any closer than 1/3 octave from the high pass crossover point. If you cannot set the low pass crossover where you want then check the ISIS display and see if the *LPF* is lit and the *HPF* indicator is flashing. If it is then you need to go to the HI-PASS menu and lower the high pass crossover point.



This is done as a safety precaution to prevent a notch filter condition.

HI-PASS MENU - Here is where you adjust the selected amplifier's high pass crossover.

Use the **UP** and **DOWN** keys to scroll through *FREQUENCY* and *SLOPE* and then press the **ENT** key to select.



FREQUENCY selects the crossover point and can be set at any 1/12th octave spaced frequency from 10 Hz to 16 kHz. (*10 HZ to 16 132 HZ*) *SX.1 Series is 10 Hz to 159 Hz in 1 Hz steps.*

Use the **UP** and **DOWN** keys to select your frequency. Press the **ESC** key to save your setting and return to the *FREQUENCY* and *SLOPE* options menu. You can now select another high pass crossover option to adjust on this amplifier if desired.



SLOPE selects the roll-off of the crossover and can be set from *OFF* to *36 DB/OCT* in 6 dB steps. *SX.1 Series is OFF to 24 dB in 6 dB Steps.*

Use the **UP** and **DOWN** keys to select your high pass crossover slope. Press the **ESC** key to save your setting and return to the *FREQUENCY* and *SLOPE* options menu. You can now select another high pass crossover option to adjust on this amplifier if desired.



When you are done adjusting the high pass crossover on this amplifier press the **ESC** key while in the *FREQUENCY* and *SLOPE* options menu to return to the AMP ADJ menu and choose another function to adjust.



NOTE:

While you are in the HI-PASS menu the *HPF* indicator on the ISIS display is lit. This indicates you are making adjustments in the HI-PASS menu.



The KICKER SXRC monitors and prevents any high pass crossover point from being set any closer than 1/3 octave from the low pass crossover point. If you cannot set the high pass crossover where you want then check the ISIS display and see if the *HPF* is lit and the *LPF* indicator is flashing. If it is then you need to go to the LO-PASS menu and raise the low pass crossover point.



This is done as a safety precaution to prevent a notch filter condition.

PHASE MENU - Here is where you can switch the polarity of each channel(s) output between 0 or 180 degrees.

Use the **UP** and **DOWN** keys to scroll through **BOTH CHNS**, **LEFT CHN** and **RIGHT CHN** then press the **ENT** key to select. *SX.1 Series does not offer Left or Right Channel option...Only 0 Degree or 180 Degree for the entire amplifier since it is a Mono-Block design. Skip this step and move to next paragraph.*



Use the **UP** or **DOWN** keys to select from **0 DEGREE** or **180 DEGREE**. Press the **ESC** key to save your setting and return to the **BOTH CHNS**, **LEFT CHN** and **RIGHT CHN** options menu. You can now select another phase option to adjust on this amplifier if desired. *Does not apply to SX.1 Series. Pressing the ESC key at this point on a SX.1 Series amplifier exits the PHASE menu.*



When you are done adjusting the phase on this amplifier press the **ESC** key while in the **BOTH CHNS**, **LEFT CHN** and **RIGHT CHN** options menu to return to the AMP ADJ menu and choose another function to adjust.



NOTE:

While you are in the PHASE menu the **PHASE** indicator on the ISIS display is lit. This indicates you are making adjustments in the PHASE menu.



There is also a **LEFT** and **RIGHT** indicator in the ISIS display that will light up indicating which channel(s) (Left and/or Right) are currently being adjusted.



By default, all channels in all amplifiers are set to 0 Degree.

MUTE MENU - Here is where you can mute each channel(s) output on the amplifier for setup or testing purposes.

Use the **UP** and **DOWN** keys to scroll through **BOTH CHNS**, **LEFT CHN** and **RIGHT CHN** then press the **ENT** key to select. *SX.1 Series does not offer Left or Right Channel option...Only Mute On or Mute Off for the entire amplifier since it is a Mono-Block design. Skip this step and move to next paragraph.*



Use the **UP** or **DOWN** keys to select from **MUTE ON** or **MUTE OFF**. Press the **ESC** key to save your setting and return to the **BOTH CHNS**, **LEFT CHN** and **RIGHT CHN** options menu. You can now select another mute option to adjust on this amplifier if desired. *Does not apply to SX.1 Series. Pressing the ESC key at this point on a SX.1 Series amplifier exits the MUTE menu.*



When you are done adjusting the mute on this amplifier press the **ESC** key while in the **BOTH CHNS**, **LEFT CHN** and **RIGHT CHN** options menu to return to the AMP ADJ menu and choose another function to adjust.



NOTE:

While you are in the MUTE menu the **MUTE** indicator on the ISIS display is lit. This indicates you are making adjustments in the MUTE menu.



There is also a **LEFT** and **RIGHT** indicator in the ISIS display that will light up indicating which channel(s) (Left and/or Right) are currently being adjusted.



If you exit the MUTE menu with any channel(s) muted (**MUTE ON**), the **MUTE** indicator in the ISIS VFD will begin flashing to indicate this.



The **MUTE** indicator will stop flashing once you un-mute the channel(s) currently muted.

KOMPRESSOR MENU - Here you select from any of the four settings for the SX Series amplifiers Digital Compressor Circuit.

Use the **UP** and **DOWN** keys to scroll through *OFF*, *RED-LINE*, *CONTOUR* or *ATTACK*.



Press the **ESC** key to save your setting and return to the AMP ADJ menu. You can now choose another function to adjust.



NOTE:

While you are in the KOMPRESSOR™ menu the *KOMP* indicator on the ISIS display is lit. This indicates you are making adjustments in the KOMPRESSOR™ menu.



See the specifications pages later in this manual for a brief description of each Kompressor™ setting and some general guidelines for their use.

KOMP. ADJ. MENU - Here you can adjust the operation threshold for the SX Series amplifiers Digital Compressor Circuit (Kompressor™).

The KOMP. ADJ. menu allows you to adjust the activation threshold (in simple terms...the volume level at which it turns on/off) through a 48 dB window, +24 dB to -24 dB. The unit comes preset from KICKER at a default level of 0.0 dB. By adjusting the threshold up or down from this point you can change when the Kompressor™ 'kicks in' in relationship to the volume level to allow for different sized speakers, acoustics or listener tastes.

Use the **UP** and **DOWN** keys to scroll through from *24 0 00* to *-24 0 00*. Remember that *0 0 00* is the default setting.



Press the **ESC** key to save your setting and return to the AMP ADJ menu. You can now choose another function to adjust.



NOTE:

While you are in the KOMP. ADJ. menu the *KOMP* indicator on the ISIS display is lit. This indicates you are making adjustments in the KOMP. ADJ. menu.



There is no right or wrong setting here, you can simply adjust when the Kompressor™ activates in relationship to volume level. Experiment around and find what works for you.

GAIN RANGE MENU - Here you can select the SX Series amplifiers' UltraMatch™ digital input gain range. The UltraMatch™ gain structure features five selectable Gain Ranges (1 volt, 2 volt, 4 volt, 8 volt and 16 volt).

In "Gear-Head" terms, the Gain Range and Gain adjustments can be compared to the gear box and gas pedal of a race car. The Gain Range represents what gear you're in and the Gain represents stepping on the gas. In this menu you are adjusting the gear box. **THE GAIN RANGE OF YOUR AMPLIFIER NEEDS TO BE CORRECTLY ADJUSTED TO PROVIDE MAXIMUM PERFORMANCE!**

Use the **UP** and **DOWN** keys to scroll through *1V RANGE*, *2V RANGE*, *4V RANGE*, *8V RANGE* or *16V RANGE*.



Press the **ESC** key to save your setting and return to the AMP ADJ menu to select another function to adjust.



NOTE:

While you are in the GAIN RANGE menu the *SYS* and *GAIN* indicators on the ISIS display are lit. This indicates you are making adjustments in the GAIN RANGE menu.



The GAIN RANGE function is a SYSTEM menu function and that is why the *SYS* indicator and the *GAIN* are lit while adjusting the GAIN RANGE function

BYPASS DSP MENU - Here you can bypass all the DSP processing for the selected SX Series amplifier and send the RCA input signal directly to the amplifier.

Use the **UP** or **DOWN** keys to select from *BYPASS OFF* or *BYPASS ON*.



Press the **ESC** key to save your setting and return to the AMP ADJ menu to select another function to adjust.



NOTE:

While you are in the BYPASS DSP menu the *SYS* indicator on the ISIS display is lit. This indicates you are making adjustments in the BYPASS DSP menu.



The BYPASS DSP function is a SYSTEM menu function and that is why the *SYS* indicator is lit while adjusting the BYPASS DSP function.

PINK NOISE MENU - Here you can activate the integrated pink noise generator of the selected SX Series amplifier and is very useful for testing and troubleshooting your system.

Pink noise is a sound made up of equal energy at all 1/3 octaves from 20 Hz to 20 kHz and sounds like the static between radio stations.

When activated, pink noise is generated by the SX amplifier's DSP and fed into both the left and right channels.

Use the **UP** or **DOWN** keys to scroll through *NOISE OFF* and *NOISE ON*.



Press the **ESC** key to save your setting and return to the AMP ADJ menu to select another function to adjust.



NOTE:

When the pink noise is activated (*NOISE ON*) the **LEFT** and **RIGHT** indicators on the ISIS display will begin blinking. This indicates that the PINK NOISE generator is active.



If you exit the PINK NOISE menu with the generator on (*NOISE ON*) the **LEFT** and **RIGHT** indicators in the ISIS VFD will stay flashing to indicate this.

The **LEFT** and **RIGHT** indicators will stop flashing once you turn off (*NOISE OFF*) the pink noise generator.



REMOTE VOL MENU - Here you can choose to have the selected SX Series amplifier's output level controlled by the Digital Remote Volume Control (DRVC).

If you wish to use the DRVC as a master volume control, raising and lowering the output level of all the amplifiers, leave all amplifiers set to *REMOTE ON*. By default, all amplifiers are set to *REMOTE ON*.

If you wish to use the DRVC as a bass level controller, raising and lowering the output level on subwoofer amplifiers only, set the REMOTE VOL to *REMOTE OFF* on your non-subwoofer amplifiers.

These are the two most common uses. You can configure whatever combination works for your particular installation.

Use the **UP** or **DOWN** keys to scroll through *REMOTE ON* and *REMOTE OFF*.



Press the **ESC** key to save your setting and return to the AMP ADJ menu to select another function to adjust.



NOTE:

While you are in the REMOTE VOL menu the **SYS** indicator on the ISIS display is lit. This indicates you are making adjustments in the REMOTE VOL menu.



GROUP ADJ

GROUP ADJ MENU - This menu item lets you select each amplifier group (up to 10 can be created in the SXRC SETUP menu) connected to the SXRC and view or adjust any of its settings.



This section describes how to adjust the settings in each group. See the SXRC SETUP section later in the manual for a complete description on amplifier group setup.

When a group is created from the SXRC SETUP menu it can be set as a LINK ON or a LINK OFF group. All of the GROUP ADJ functions are described in this section but what you can adjust for the group will vary based on this setting.

A LINK ON group allows you to adjust each of the following settings and they are shared for each amplifier in the group:

» GAIN
» EQ
» LO-PASS
» HI-PASS
» PHASE
» MUTE
» KOMPRESSOR
» KOMP ADJ
» GAIN RANGE
» PINK NOISE

A LINK OFF group allows you to adjust each of the following settings and they are shared for each amplifier in the group:

» GAIN
» MUTE
» KOMPRESSOR
» PINK NOISE

Look for more details and explanations on grouping amplifiers and setting them up in the SXRC SETUP menu of this manual.

Once you select the **GROUP ADJ** menu a list of all the groups created by the SXRC will be available. The list will show the current name of the selected group. This will either be the default name from KICKER (**GROUP--01** through **GROUP--10**) or any name you may have assigned to the group.



Use the **UP** and **DOWN** keys to scroll through the list of available groups..



Once you have found the group you wish to adjust simply press the **ENT** key to select it.

NOTE:

If the ISIS display reads **N/A** when you enter the GROUP ADJ menu, this signifies that no amplifier groups have been created.



Once the group you want to adjust is selected you will be able to choose from the following items (depending on LINK setting).

»GAIN
 »EQ
 »LO-PASS
 »HI-PASS
 »PHASE
 »MUTE
 »KOMPRESSOR
 »KOMP. ADJ
 »GAIN RANGE
 »PINK NOISE

Use the **UP** and **DOWN** keys to scroll through the selections above and press the **ENT** key to select.



GAIN MENU - Here is where you adjust the selected group's gain controls. All amplifiers in the group will be adjusted up or down when you adjust the gain control.

If each amplifier has different gain settings, the SXRC will display the gain level of the highest amplifier in the group. It also monitors and maintains any differences between channels or individual amplifiers that you may have set separately.

If you can not adjust a group up or down, then it means the channel differences are being maintained and there is no where to go. You will need to adjust each amplifier individually or set each amplifier's gain to a similar setting.

Here are four of the many possible examples.

Example 1

Group-01 has two amplifiers in it, amp 1 has both channels gain set at **12.0** while amp 2 is at **0.0**. When you select this group to adjust the gain you will see **12.0** in the display, the highest gain setting of the group.

| | | | | | |
|-------|-------|--------|-------|-------|-------|
| AMP1 | | KICKER | | AMP2 | |
| LOCK | LEFT | SYS | RIGHT | MUTE | KOMP |
| GAIN | EQ | LFF | HPF | PHASE | |
| 12.0 | | | | 12.0 | |
| MEM-1 | MEM-2 | MEM-3 | MEM-4 | MEM-5 | MEM-6 |

When you try to increase or decrease the gain setting of this group, nothing will happen. Since the gain range is 12 dB (0.0 dB to 12.0 dB) there is no way to increase or decrease the gain and maintain 12 dB of difference between the amplifiers. The SXRC is maintaining the differences you set between the amplifiers.

| | | | | | |
|-------|-------|--------|-------|-------|-------|
| AMP1 | | KICKER | | AMP2 | |
| LOCK | LEFT | SYS | RIGHT | MUTE | KOMP |
| GAIN | EQ | LFF | HPF | PHASE | |
| 00 | | | | 00 | |
| MEM-1 | MEM-2 | MEM-3 | MEM-4 | MEM-5 | MEM-6 |

| | | | | | |
|-------|-------|--------|-------|-------|-------|
| AMP1 | | KICKER | | AMP2 | |
| LOCK | LEFT | SYS | RIGHT | MUTE | KOMP |
| GAIN | EQ | LFF | HPF | PHASE | |
| 12.0 | | | | 12.0 | |
| MEM-1 | MEM-2 | MEM-3 | MEM-4 | MEM-5 | MEM-6 |

Example 2

Group-02 has two amplifiers in it, amp 1 has channel gains set at **3.0** (Left) and **9.0** (Right) while amp 2 is at **5.0** (Left) and **3.0** (Right). When you select this group to adjust the gain you will see **5.0** (Left) and **9.0** (Right) in the display, the highest gain settings of the group.

| | | | | | |
|-------|-------|--------|-------|-------|-------|
| AMP1 | | KICKER | | AMP2 | |
| LOCK | LEFT | SYS | RIGHT | MUTE | KOMP |
| GAIN | EQ | LFF | HPF | PHASE | |
| 3.0 | | | | 9.0 | |
| MEM-1 | MEM-2 | MEM-3 | MEM-4 | MEM-5 | MEM-6 |

Since the gain range is 12 dB (0.0 dB to 12.0 dB) for both channels, when you try to increase or decrease the gain setting of this group you will only have 3 dB of movement in either direction. (3.0 dB to 0.0 dB in the Left channel) and (9.0 dB to 12.0 dB in the Right channel) This will maintain all the channel and amplifier gain differences while allowing you to adjust the gain of all the amplifiers.

| | | | | | |
|-------|-------|--------|-------|-------|-------|
| AMP1 | | KICKER | | AMP2 | |
| LOCK | LEFT | SYS | RIGHT | MUTE | KOMP |
| GAIN | EQ | LFF | HPF | PHASE | |
| 5.0 | | | | 3.0 | |
| MEM-1 | MEM-2 | MEM-3 | MEM-4 | MEM-5 | MEM-6 |

| | | | | | |
|-------|-------|--------|-------|-------|-------|
| AMP1 | | KICKER | | AMP2 | |
| LOCK | LEFT | SYS | RIGHT | MUTE | KOMP |
| GAIN | EQ | LFF | HPF | PHASE | |
| 5.0 | | | | 9.0 | |
| MEM-1 | MEM-2 | MEM-3 | MEM-4 | MEM-5 | MEM-6 |

Example 3

Group-07 has two amplifiers in it, amp 1 has both channels gain set at 0 0 while amp 2 is at 0 0. When you select this group to adjust the gain you will see 0 0 in the display, the highest gain setting of the group.

Since the gain range is 12 dB (0.0 dB to 12.0 dB) and both amplifier's channels are set at 0.0 dB, the SXRC will let you adjust through the full gain range. When you try to increase or decrease the gain setting of this group, you will have a full 12 dB swing up and down on both channels.

Example 4

Group-09 has two amplifiers in it, amp 1 has channel gains set at 0 0 (Left) and 12 0 (Right) while amp 2 is at 0 0 (Left) and 12 0 (Right). When you select this group to adjust the gain you will see 0 0 (Left) and 12 0 (Right) in the display, the highest gain settings of the group.

Since the gain range is 12 dB (0.0 dB to 12.0 dB) for both channels, and each channel on each amplifier is separated by 12 dB, you can only adjust the gain if you do each channel separately. Choosing BOTH CHNS will not work but choosing just the LEFT CHN or RIGHT CHN will allow full adjustment of 12 dB on that channel.



Use the **UP** and **DOWN** keys to scroll through *LEFT CHN*, *RIGHT CHN* or *BOTH CHNS* and then press the **ENT** key to select. *SX.1 Series do not have Left or Right channel options since it is a Mono-Block design. Skip this step and move to next paragraph.*

Now use the **UP** and **DOWN** keys to increase or decrease the gain of the selected group's channel(s) in .5 dB increments from 0 dB to +12 dB. (0 0 to 12 0)

Press the **ESC** key to save your adjustment and return to the *LEFT*, *RIGHT*, *BOTH* options menu. You can now select another channel to adjust in this group if desired. *Does not apply to SX.1 Series. Pressing the ESC key at this point on a SX.1 Series amplifier exits the GAIN menu.*

When you are done adjusting the gain in this group press the **ESC** key while in the *LEFT CHN*, *RIGHT CHN*, *BOTH CHNS* options menu to return to the **GROUP ADJ** menu and choose another function to adjust.

NOTE:

While you are in the **GAIN** menu the *GAIN* indicator on the ISIS VFD display is lit. This indicates you are making adjustments in the **GAIN** menu.

The *LEFT* and *RIGHT* indicators will light up as well to indicate which amplifier's channel(s) you are currently adjusting.



EQ MENU - Here is where you adjust the selected group's EQ controls. All amplifiers in the group will be adjusted.

Use the **UP** and **DOWN** keys to scroll through *FREQUENCY*, *BOOST/CUT* and *BANDWIDTH* and then press the **ENT** key to select.



FREQUENCY selects the center frequency of the equalizer and can be set at any 1/12th octave spaced frequency from 20 Hz - 20 kHz. (20 Hz to 20325 Hz) *SX.1 Series is 10 Hz to 200 Hz in 1 Hz Steps.*

Use the **UP** and **DOWN** keys to select your frequency. Press the **ESC** key to save your setting and return to the *FREQUENCY*, *BOOST/CUT*, *BANDWIDTH* options menu. You can now select another equalizer option to adjust on this group if desired.



BANDWIDTH (better known as Q) can be set from 5 to 10 in .5 increments. In simple terms, lower Q effects more frequencies around the center frequency while higher Q effects fewer frequencies around the center frequency.

As an example, if our center frequency is 100 HZ, a Q of .5 (area in gray) effects many more frequencies around 100 Hz than a Q of 10 (area in black) There is no right or wrong Q, you use whatever fits the needs of the system or personal taste.

KICKER uses a default Q of 3.

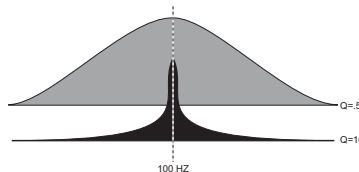

Use the **UP** and **DOWN** keys to select your bandwidth (Q) value and press the **ESC** to save your setting and return to the *FREQUENCY*, *BOOST/CUT*, *BANDWIDTH* options menu. You can now select another equalizer option to adjust in this group if desired.



BOOST/CUT is where you boost or cut the equalizer and has a range of 36 dB; -18 dB to +18 dB in .5 dB steps. Keep in mind that for every 3 dB of boost you are requiring the amplifier to use twice as much power in that equalized area. The default setting from KICKER is *FLAT* (No boost or cut).

Use the **UP** and **DOWN** keys to adjust your boost or cut and press the **ESC** key to save your setting and return to the *FREQUENCY*, *BOOST/CUT*, *BANDWIDTH* options menu. You can now select another equalizer option to adjust in this group if desired.



When you are done adjusting the equalizer in this group press the **ESC** key while in the *FREQUENCY*, *BOOST/CUT*, *BANDWIDTH* options menu to return to the GROUP ADJ menu and choose another function to adjust.



NOTE:

While you are in the EQ menu the *EQ* indicator on the ISIS display is lit. This indicates you are making adjustments in the EQ menu.



LO-PASS MENU - Here is where you adjust the selected group's low pass crossover controls. All amplifiers in the group will be adjusted.

Use the **UP** and **DOWN** keys to scroll through *FREQUENCY* and *SLOPE* and then press the **ENT** key to select.



FREQUENCY selects the crossover point and can be set at any 1/12th octave spaced frequency from 30 Hz to 20 kHz. (30 Hz to 20325 Hz) SX.1 Series is 30 Hz to 200 Hz in 1 Hz steps.

Use the **UP** and **DOWN** keys to select your frequency. Press the **ESC** key to save your setting and return to the *FREQUENCY* and *SLOPE* options menu. You can now select another low pass crossover option to adjust in this group if desired.



SLOPE selects the roll-off of the crossover and can be set from OFF to 36 DB/OCT in 6 dB steps. SX.1 Series is OFF to 48 dB in 6 dB Steps.

Use the **UP** and **DOWN** keys to select your low pass crossover slope. Press the **ESC** key to save your setting and return to the *FREQUENCY* and *SLOPE* options menu. You can now select another low pass crossover option to adjust in this group if desired.



When you are done adjusting the low pass crossover in this group press the **ESC** key while in the *FREQUENCY* and *SLOPE* options menu to return to the GROUP ADJ menu and choose another function to adjust.



NOTE:

While you are in the LO-PASS menu the *LPF* indicator on the ISIS display is lit. This indicates you are making adjustments in the LO-PASS menu.



The KICKER SXRC monitors and prevents any low pass crossover point from being set any closer than 1/3 octave from the high pass crossover point. If you cannot set the low pass crossover where you want then check the ISIS display and see if the *LPF* is lit and the *HPF* indicator is flashing. If it is then you need to go to the GROUP ADJ. HI-PASS menu and lower the high pass crossover point.



This is done as a safety precaution to prevent a notch filter condition.

HI-PASS MENU - Here is where you adjust the selected group's high pass crossover controls. All amplifiers in the group will be adjusted.

Use the **UP** and **DOWN** keys to scroll through *FREQUENCY* and *SLOPE* and then press the **ENT** key to select.



FREQUENCY selects the crossover point and can be set at any 1/12th octave spaced frequency from 10 Hz to 16 kHz. (*10 Hz to 16 132 Hz*) *SX.1 Series is 10 Hz to 159 Hz in 1 Hz steps.*

Use the **UP** and **DOWN** keys to select your frequency. Press the **ESC** key to save your setting and return to the *FREQUENCY* and *SLOPE* options menu. You can now select another high pass crossover option to adjust in this group if desired.



SLOPE selects the roll-off of the crossover and can be set from *OFF* to *36 DB/OCT* in 6 dB steps. *SX.1 Series is OFF to 24 dB in 6 dB Steps.*

Use the **UP** and **DOWN** keys to select your high pass crossover slope. Press the **ESC** key to save your setting and return to the *FREQUENCY* and *SLOPE* options menu. You can now select another high pass crossover option to adjust in this group if desired.



When you are done adjusting the high pass crossover in this group press the **ESC** key while in the *FREQUENCY* and *SLOPE* options menu to return to the **GROUP ADJ** menu and choose another function to adjust.



NOTE:

While you are in the HI-PASS menu the *HPF* indicator on the ISIS display is lit. This indicates you are making adjustments in the HI-PASS menu.



The KICKER SXRC monitors and prevents any high pass crossover point from being set any closer than 1/3 octave from the low pass crossover point. If you cannot set the high pass crossover where you want then check the ISIS display and see if the *HPF* is lit and the *LPF* indicator is flashing. If it is then you need to go to the **LO-PASS** menu and raise the low pass crossover point.



This is done as a safety precaution to prevent a notch filter condition.

PHASE MENU - Here is where you can adjust the selected group's polarity output on each channel(s) between 0 or 180 degrees. All amplifiers in the group will be adjusted.

Use the **UP** and **DOWN** keys to scroll through **BOTH CHNS**, **LEFT CHN** and **RIGHT CHN** then press the **ENT** key to select. *SX.1 Series does not offer Left or Right Channel option...Only 0 Degree or 180 Degree for the entire amplifier since it is a Mono-Block design. Skip this step and move to next paragraph.*



Use the **UP** or **DOWN** keys to select from **0 DEGREE** or **180 DEGREE**. Press the **ESC** key to save your setting and return to the both **CHNS**, **LEFT CHN** and **RIGHT CHN** options menu. You can now select another phase option to adjust in this group if desired. *Does not apply to SX.1 Series. Pressing the ESC key at this point on a SX.1 Series amplifier exits the PHASE menu.*



When you are done adjusting the phase in this group press the **ESC** key while in the **BOTH CHNS**, **LEFT CHN** and **RIGHT CHN** options menu to return to the **GROUP ADJ** menu and choose another function to adjust.



NOTE:

While you are in the **PHASE** menu the **PHASE** indicator on the ISIS VFD display is lit. This indicates you are making adjustments in the **PHASE** menu.



There is also a **LEFT** and **RIGHT** indicator in the ISIS display that will light up indicating which channel(s) (Left and/or Right) are currently being adjusted.



By default, all channels in all amplifiers are set to 0 Degree.

MUTE MENU - Here is where you can mute each channel(s) output in the selected group for setup or testing purposes.

Use the **UP** and **DOWN** keys to scroll through **BOTH CHNS**, **LEFT CHN** and **RIGHT CHN** then press the **ENT** key to select. *SX.1 Series does not offer Left or Right Channel option...Only Mute On or Mute Off for the entire amplifier since it is a Mono-Block design. Skip this step and move to next paragraph.*



Use the **UP** or **DOWN** keys to select from **MUTE ON** or **MUTE OFF**. Press the **ESC** key to save your setting and return to the both **CHNS**, **LEFT CHN** and **RIGHT CHN** options menu. You can now select another mute option to adjust in this group if desired. *Does not apply to SX.1 Series. Pressing the ESC key at this point on a SX.1 Series amplifier exits the MUTE menu.*



When you are done adjusting the mute in this group press the **ESC** key while in the **BOTH CHNS**, **LEFT CHN** and **RIGHT CHN** options menu to return to the **GROUP ADJ** menu and choose another function to adjust.



NOTE:

While you are in the MUTE menu the **MUTE** indicator on the ISIS display is lit. This indicates you are making adjustments in the MUTE menu.



There is also a **LEFT** and **RIGHT** indicator in the ISIS display that will light up indicating which channel(s) (Left and/or Right) are currently being adjusted.



If you exit the MUTE menu with any group channel(s) muted (**MUTE ON**), the **MUTE** indicator in the ISIS display will begin flashing to indicate this.



The **MUTE** indicator will stop flashing once you un-mute the group channel(s) currently muted.

KOMPRESSOR MENU - Here you can adjust the selected group's Kompressor™ settings. The function will vary depending on if this is a LINK ON or LINK OFF group. Both functions are described below.

LINK ON

In a LINK ON group, each amplifier in the group shares the exact same Kompressor™ setting.

Use the **UP** or **DOWN** keys to scroll through *OFF*, *RED-LINE*, *CONTOUR* or *ATTACK*.



Press the **ESC** key to save your setting and return to the GROUP ADJ menu and choose another function to adjust.



LINK OFF

In a LINK OFF group, each amplifier in the group has its own unique Kompressor setting that has been selected from the AMP ADJ menu. Here you can, as a group, turn the Kompressor™ OFF or ON, ON being the individual setting you selected from the AMP ADJ menu.

Use the **UP** or **DOWN** keys to scroll through *OFF* and *ON*.



Press the **ESC** key to save your setting and return to the GROUP ADJ menu and choose another function to adjust.



Example

You have selected a group to adjust which contains four amplifiers and the group has the LINK property set to OFF. The Kompressor™ settings on each amp are as follows:

- Amp 1 - Off
- Amp 2 - Attack
- Amp 3 - Contour
- Amp 4 - Red-Line

If you select the Kompressor™ and turn it *OFF* for this group the amplifier's Kompressor™ will be set as:

- Amp 1 - Off
- Amp 2 - Off
- Amp 3 - Off
- Amp 4 - Off

If you select the Kompressor™ and turn it *ON* for this group the amplifier's Kompressor™ will be set as:

- Amp 1 - Off
- Amp 2 - Attack
- Amp 3 - Contour
- Amp 4 - Red-Line

NOTE:

While you are in the KOMPRESSOR™ menu the *KOMP* indicator on the ISIS display is lit. This indicates you are making adjustments in the KOMPRESSOR™ menu.



See the specifications pages later in this manual for a brief description of each Kompressor™ setting and some general guidelines for their use.

KOMP. ADJ. MENU - Here you can adjust the selected group's operation threshold for each SX Series amplifiers Kompressor™.

The KOMP. ADJ. menu allows you to adjust the activation threshold (in simple terms...the volume level at which it turns on/off) through a 48 dB window, +24 dB to -24 dB. The unit comes preset from KICKER at a default level of 0.0 dB. By adjusting the threshold up or down from this point you can change when the Kompressor™ 'kicks in' in relationship to the volume level to allow for different sized speakers, acoustics or listener tastes.

Use the **UP** and **DOWN** keys to scroll through from **24 0 00** to **-24 0 00**. Remember that **0 0 00** is the default setting.



Press the **ESC** key to save your setting and return to the GROUP ADJ menu and choose another function to adjust.



NOTE:

While you are in the KOMP. ADJ. menu the **KOMP** indicator on the ISIS display is lit. This indicates you are making adjustments in the KOMP. ADJ. menu.



There is no right or wrong setting here, you can simply adjust when the Kompressor™ activates in relationship to volume level. Experiment around and find what works for you.

GAIN RANGE MENU - Here you can adjust the selected group's UltraMatch™ digital input gain range. The UltraMatch™ gain structure features five selectable Gain Ranges (1 volt, 2 volt, 4 volt, 8 volt and 16 volt).

In "Gear-Head" terms, the Gain Range represents what gear you're in and the Gain adjustment represents stepping on the gas. In this menu you are adjusting the gear box. This group adjustment sets the Gain Range of all the amplifiers in the group to the same setting. **THE GAIN RANGE OF YOUR AMPLIFIER NEEDS TO BE CORRECTLY ADJUSTED TO PROVIDE MAXIMUM PERFORMANCE!** *See you SX Series Amplifier Quick Start Guide for details on Gain Range if required.*

Use the **UP** and **DOWN** keys to scroll through **1V RANGE**, **2V RANGE**, **4V RANGE**, **8V RANGE** or **16V RANGE**.



Press the **ESC** key to save your setting and return to the GROUP ADJ menu to select another group function to adjust.



NOTE:

While you are in the GAIN RANGE menu the **SYS** and **GAIN** indicators on the ISIS display are lit. This indicates you are making adjustments in the GAIN RANGE menu.



The GAIN RANGE function is a SYSTEM menu function and that is why the **SYS** and the **GAIN** indicators are lit while adjusting the GAIN RANGE function.

PINK NOISE MENU - Here you can activate the selected group's integrated pink noise generator for testing and troubleshooting your system.

Pink noise is a sound made up of equal energy at all 1/3 octaves from 20 Hz to 20 kHz and sounds like the static between radio stations.

When activated, pink noise is generated by all the SX Series amplifier's in this selected group.

Use the **UP** or **DOWN** keys to scroll through *NOISE OFF* and *NOISE ON*.



Press the **ESC** key to save your setting and return to the GROUP ADJ menu and choose another function to adjust.



NOTE:

When the pink noise is activated (*NOISE ON*) the **LEFT** and **RIGHT** indicators on the ISIS display will begin blinking. This indicates that the PINK NOISE generator is active.



If you exit the PINK NOISE menu with the generator on (*NOISE ON*) the **LEFT** and **RIGHT** indicators in the ISIS display will stay flashing to indicate this.

The **LEFT** and **RIGHT** indicators will stop flashing once you turn off (*NOISE OFF*) the pink noise generator.



SICK BAY™

SICK BAY MENU - This menu item lets you view each amplifier's built in troubleshooting and diagnostic tools.



The available tools in the Sick Bay™ menu are:

- » VOLT NOW
- » VOLT MIN
- » VOLT MAX
- » TEMP NOW
- » TEMP MAX
- » RUN TIME
- » HISTORY
- » PINK NOISE
- » NO. OF AMPS

Use the **UP** and **DOWN** keys to scroll through the selections above.



When you have the SICK BAY menu item selected that you want to view simply press the **ENT** key to select it.



NOTE:

The following 'Helpful Hint' applies to any menu item in the Sick Bay™ which has a scrolling list of amplifiers to choose from.

Use the **UP** or **DOWN** keys to scroll through the list of available amplifiers. If you have several of the same model of amplifier installed and did not change the name prior to installing the SXRC then you will see the same name when you press the **UP** or **DOWN** keys on the SXRC. In other words it appears like nothing changed. It did...just read on.

To help you identify which amp you are currently viewing simply press and hold the **ENT** key and the Remote Address of the amplifier will be displayed. This will aid you in determining which amp you are currently viewing when you have multiple amps of the same make or name.

VOLT NOW MENU - Here you can view the current voltage reading at each amplifier's +12 volt terminal.

Once you select the **VOLT NOW** menu, a list of all the amplifiers connected to the SXRC will be displayed in a scrolling list.

Use the **UP** or **DOWN** keys to scroll through the list of available amplifiers.



When you have the amplifier selected you wish to view simply press the **ENT** key to select it.

The selected amplifier's current +12 volt terminal voltage reading will be displayed in real time.

When done viewing the current amplifier's voltage, press the **ESC** key to return to the list of available amplifiers.

You can now select another amplifier by using the **UP** or **DOWN** keys and view its current +12 volt terminal voltage by pressing the **ENT** key

OR

Press the **ESC** key to return to the SICK BAY menu and select another function.



VOLT MIN MENU - Here you can view the lowest voltage seen at each amplifier's +12 volt terminal since being installed.

Once you select the **VOLT MIN** menu, a list of all the amplifiers connected to the SXRC will be displayed in a scrolling list.

Use the **UP** or **DOWN** keys to scroll through the list of available amplifiers.

When you have the amplifier selected you wish to view simply press the **ENT** key to select it.

The selected amplifier's minimum +12 volt terminal reading will be displayed.

When done viewing the current amplifier's minimum voltage, press the **ESC** key to return to the list of available amplifiers.

You can now select another amplifier by using the **UP** or **DOWN** keys and view its minimum voltage by pressing the **ENT** key

OR

Press the **ESC** key to return to the SICK BAY menu and select another function.



VOLT MAX MENU - Here you can view the highest voltage seen at each amplifier's +12 volt terminal since being installed.

Once you select the **VOLT MAX** menu, a list of all the amplifiers connected to the SXRC will be displayed in a scrolling list.

Use the **UP** or **DOWN** keys to scroll through the list of available amplifiers.

When you have the amplifier selected you wish to view simply press the **ENT** key to select it.

The selected amplifier's maximum +12 volt terminal reading will be displayed.

When done viewing the current amplifier's maximum voltage, press the **ESC** key to return to the list of available amplifiers.

You can now select another amplifier by using the **UP** or **DOWN** keys and view its maximum voltage by pressing the **ENT** key

OR

Press the **ESC** key to return to the SICK BAY menu and select another function.



TEMP NOW MENU - Here you can view the current operating temperature of the selected amplifier.

Once you select the **TEMP NOW** menu, a list of all the amplifiers connected to the SXRC will be displayed in a scrolling list.

Use the **UP** or **DOWN** keys to scroll through the list of available amplifiers.

When you have the amplifier selected you wish to view simply press the **ENT** key to select it.

The selected amplifier's current operating temperature reading will be displayed.

When done viewing the current amplifier's temperature, press the **ESC** key to return to the list of available amplifiers.

You can now select another amplifier by using the **UP** or **DOWN** keys and view its temperature by pressing the **ENT** key.

OR

Press the **ESC** key to return to the SICK BAY menu and select another function.



TEMP MAX MENU - Here you can view the highest operating temperature of the selected amplifier since its installation.

Once you select the **TEMP MAX** menu, a list of all the amplifiers connected to the SXRC will be displayed in a scrolling list.

Use the **UP** or **DOWN** keys to scroll through the list of available amplifiers.

When you have the amplifier selected you wish to view simply press the **ENT** key to select it.

The selected amplifier's maximum operating temperature reading will be displayed.

When done viewing the current amplifier's maximum temperature, press the **ESC** key to return to the list of available amplifiers.

You can now select another amplifier by using the **UP** or **DOWN** keys and view its maximum temperature by pressing the **ENT** key

OR

Press the **ESC** key to return to the SICK BAY menu and select another function.



RUN TIME MENU - Here you can view the total time that the selected amplifier has been powered up since installation in 1/10th of an hour increments.

Once you select the *RUN TIME* menu, a list of all the amplifiers connected to the SXRC will be displayed in a scrolling list.

Use the **UP** or **DOWN** keys to scroll through the list of available amplifiers.

When you have the amplifier selected you wish to view simply press the **ENT** key to select it.

The selected amplifier's total run time reading will be displayed.

When done viewing the current amplifier's run time, press the **ESC** key to return to the list of available amplifiers.

You can now select another amplifier by using the **UP** or **DOWN** keys and view its run time by pressing the **ENT** key.

OR

Press the **ESC** key to return to the SICK BAY menu and select another function.



HISTORY MENU - Here you can view the last 5 fault codes and how long ago they happened versus the run time clock for the selected amplifier. The following conditions are logged:

- THERMAL* - Thermal cutoff protection engaged.
- OVERLOAD* - Short circuit protection engaged.
- LO-VOLT* - Low voltage protection engaged.
- HI-VOLT* - High voltage protection engaged.
- SERVICE* - Amp requires service by KICKER.

Once you select the *HISTORY* menu, a list of all the amplifiers connected to the SXRC will be displayed in a scrolling list.

Use the **UP** or **DOWN** keys to scroll through the list of available amplifiers.

When you have the amplifier selected you wish to view simply press the **ENT** key to select it.

If there have not been any fault codes triggered on the selected amplifier, the display will read *NO HISTORY*.

If there are fault codes listed they are numbered in order from 1 (the newest) to 5 (the oldest). When a new fault code is triggered the fault code stack rolls and the oldest of the 5 is discarded.



Use the **UP** or **DOWN** keys to scroll through the list of fault codes stored for this selected amplifier.

To see how long ago a fault code was triggered, press the **ENT** key.

The display will now show you how long ago this fault code was triggered in relation to the built in Run Time clock. So a display showing *T- 45 HR* is telling you this fault code was triggered 4.5 hours ago from the current Run Time clock.

Press the **ESC** key to return to the history list for the selected amplifier.

When done viewing the current amplifier's history, press the **ESC** key to return to the list of available amplifiers.

You can now select another amplifier by using the **UP** or **DOWN** keys and view its history by pressing the **ENT** key.

OR

Press the **ESC** key to return to the SICK BAY menu and select another function.



PINK NOISE MENU - Here you can activate the integrated pink noise generator of the SX Series amplifiers. This is very useful for testing and troubleshooting your system. See the Help section of this manual for more details on pink noise use.

Pink noise is a sound made up of equal energy at all 1/3 octaves from 20 Hz to 20 kHz and sounds like the static between radio stations.

When activated, pink noise is generated by the SX amplifier's DSP and fed into both the left and right channels.

Use the **UP** or **DOWN** keys to scroll through *SELECT AMP* or *ALL AMPS* and press the **ENT** key to select.

ALL AMPS allows you to turn the pink noise generator on and off for all SX Series amplifiers connected to the SXRC *ALL AMPS* at the same time.

SELECT AMP allows you to select each amp individually and turn on or off its pink noise generator.

If you chose *ALL AMPS* then use the **UP** or **DOWN** keys to select *NOISE ON* or *NOISE OFF*.

When done adjusting all the amplifier's pink noise generator, press the **ESC** key to return to the *ALL AMPS*, *SELECT AMP* menu.



If you chose *SELECT AMP* then use the **UP** or **DOWN** keys to scroll through the list of available amplifiers and press **ENT** to select.



You can then use the **UP** or **DOWN** keys to select *NOISE ON* or *NOISE OFF* for the selected amplifier.



When done adjusting the current amplifier's pink noise generator, press the **ESC** key to return to the list of available amplifiers.



You can now select another amplifier by using the **UP** or **DOWN** keys and adjust its pink noise generator by pressing the **ENT** key.



OR

Press the **ESC** key to return to the *ALL AMPS, SELECT AMP* menu.



Pressing the **ESC** key again while in the *ALL AMPS, SELECT AMP* menu will return you to the *SICK BAY* menu to select another menu item.



NOTE:

When the pink noise is activated (*NOISE ON*) the *LEFT* and *RIGHT* indicators on the ISIS display will begin blinking. This indicates that the **PINK NOISE** generator is active.



If you exit the **PINK NOISE** menu with the generator on (*NOISE ON*) the *LEFT* and *RIGHT* indicators in the ISIS display will stay flashing to indicate this.

The *LEFT* and *RIGHT* indicators will stop flashing once you turn off (*NOISE OFF*) the pink noise generator.

NO OF AMPS MENU - Here you can see how many SX Series amplifiers are currently connected to the SXRC.

Once you select the **NO OF AMPS** menu, the SXRC will display how many amplifiers are currently connected to it. (from 1 to 16 units)



When done viewing the number of amplifiers connected to the SXRC, press the **ESC** key to return to the SICK BAY menu.



SXRC SETUP

SXRC SETUP MENU - This menu item lets you select and adjust many operating parameters for your SXRC, create amplifier groups, change names, change lock codes and update your SX Series amplifier software. A lot of very powerful tools and functions are built into your SXRC.



Here is a list of the menu items contained in the SXRC SETUP menu.

- | | |
|--------------|--------------|
| » DISPLAY | » SAVE ALL |
| » AUTOSEARCH | » LOCK CODE |
| » GROUP AMPS | » RESET SXRC |
| » SXRC NAME | » SW UPDATES |
| » MEM NAME | » ABOUT |
| » AMP NAME | |

Use the **UP** and **DOWN** arrow keys to scroll through the available selections in the SXRC SETUP menu.



When you have the menu item selected that you want to view or adjust simply press the **ENT** key to select it.



DISPLAY MENU - Here you can adjust the items displayed in the **DEFAULT** menu as well as customize the display to fit your use.

Here is a list of the menu items contained in the **DISPLAY** menu.

| | |
|---------------------|----------------------|
| » BRIGHTNESS | » SET TIME |
| » TEMP. C/F | » INFO AMP |
| » HOLD TIME | » LED ON LVL |
| » SCANSWNER | » LED DIM LVL |
| » SET DATE | » LED TIME |

Use the **UP** and **DOWN** arrow keys to scroll through the available selections in the **DISPLAY** menu.



When you have the menu item selected that you want to view or adjust simply press the **ENT** key to select it.



BRIGHTNESS MENU - Here you can adjust the intensity level of the **ISIS** display from 1 of 5 different levels.

Use the **UP** and **DOWN** arrow keys to scroll through the available settings: **HIGH, MEDIUM, LOW, MINIMUM.**



Press the **ESC** key to save your setting and return to the **DISPLAY** menu to select another display function to adjust.



TEMP. C/F MENU - Here you can select in which format, Celsius or Fahrenheit, the temperature readings are displayed.

Use the **UP** or **DOWN** arrow keys to scroll through the available settings: **FAHRENHEIT** and **CELSIUS.**



Press the **ESC** key to save your setting and return to the **DISPLAY** menu to select another display function to adjust.



HOLD TIME MENU - Here you can select how long each item in the **DEFAULT** menu pauses (1 to 11 seconds) before scrolling continues. The default setting for this 2 seconds.

Use the **UP** and **DOWN** arrow keys to scroll through the available settings: **1 SEC. to 11 SEC.** in 1 second increments.



Press the **ESC** key to save your setting and return to the **DISPLAY** menu to select another display function to adjust.



SCREENSAVER MENU - Here you can turn on (*AUTO*) or off (*OFF*) the built in screensaver function for the ISIS display. If turned on, the display will power down and go blank after 90 seconds with no key press activity. Pressing any key on the SXRC will wake up the screen.

Use the **UP** or **DOWN** arrow keys to scroll through the available settings: *OFF* and *AUTO*.



Press the **ESC** key to save your setting and return to the DISPLAY menu to select another display function to adjust.



SET DATE MENU - Here is where you can set the proper date (Month, Day, Year) that is displayed in the scrolling DEFAULT menu. The SXRC contains a backup battery good for 5 years to maintain this setting even if power is removed from the unit.



The month will begin blinking when you enter the menu. Use the **UP** and **DOWN** arrow keys to scroll through and set the month. Press the **ENT** key to save the month setting and advance to the day.



The day will begin blinking, use the **UP** and **DOWN** arrow keys to scroll through and set the day. Press the **ENT** key to save the day setting and advance to the year.



The year will begin blinking, use the **UP** and **DOWN** arrow keys to scroll through and set the year. Press the **ENT** key to save the year setting and return to the month.



When you have set the month, day and year correctly then press and hold the HOME key for 1.5 seconds to save your settings and return to the DISPLAY menu.



When saved the display will return to the DISPLAY menu.

NOTE:

After 3 minutes without any key press activity, the SXRC will save the current date settings and return to the scrolling DEFAULT menu.

SET TIME MENU - Here is where you can set the proper time am/pm format that is displayed in the scrolling DEFAULT menu. It is also protected by the backup battery.



The hour will begin blinking when you enter the menu. Use the **UP** and **DOWN** arrow keys to scroll through and set the hour. Press the **ENT** key to save the hour setting and advance to the minutes.



The minutes will begin blinking, use the **UP** and **DOWN** arrow keys to scroll through and set the minutes. Press the **ENT** key to save the minutes setting and advance to the am/pm selection.



The am/pm indicator will begin blinking, use the **UP** and **DOWN** arrow keys to select *AM* or *PM*. Press the **ENT** key to save the am/pm setting and advance to the hour.



When you have set the time correctly then press and hold the **HOME** key for 1.5 seconds to save your settings and return to the **DISPLAY** menu.



NOTE:

After 3 minutes without any key press activity, the SXRC will save the current time settings and return to the scrolling **DEFAULT** menu.

INFO AMP MENU - Here is where you select which of the amplifiers connected to the SXRC has its voltage and temperature scrolled through the **DEFAULT** menu.



Once you select the **INFO AMP** menu, a list of all the amplifiers connected to the SXRC will be displayed in a scrolling list. Use the **UP** or **DOWN** keys to scroll through the list of available amplifiers.



To help you identify which amp you are currently viewing simply press and hold the **ENT** key and the Remote Address of the amplifier will be displayed. This will aid you in determining which amp you are currently viewing when you have multiple amps of the same make or name.



When you have the amplifier selected you wish to use simply press the **ESC** key to select it and return to the **DISPLAY** menu.



NOTE:

All of the amplifier's voltage and temperature can be viewed from the Sick Bay, this simply selects which amplifier gets the privilege of being up front on the **DEFAULT** menu all the time. You can always change this to any other amplifier connected to the SXRC if jealousy breaks out among the ranks.

LED ON LVL MENU - The backlit keys on the SXRC have two intensity modes, On and Dim. When the keys are pressed and in use they will brighten to the level set in this menu. The default setting from KICKER is 11.



Use the **UP** and **DOWN** arrow keys to scroll through the available settings:
 !! (Brightest) to 0 (Off)



Press the **ESC** key to save the setting and return to the DISPLAY menu.



NOTE:

As you lower the brightness level of the LED ON LVL you may not be able to reach the 0 setting. This is because the On level can not be set any lower than the current Dim level. So...if the Dim level (discussed next) is set to 3, you would only be able to lower the On level to 3. If you want to use a lower value for the On level you will need to lower the value of the Dim level.

LED DIM LVL MENU - The backlit keys on the SXRC have two intensity modes, On and Dim. When the keys are not being used they will dim to the level set in this menu. The default setting from KICKER is 3.



Use the **UP** and **DOWN** arrow keys to scroll through the available settings:
 !! (Brightest) to 0 (Off)



Press the **ESC** key to save the setting and return to the DISPLAY menu.



NOTE:

As you raise the brightness level of the LED DIM LVL you may not be able to reach the 11 setting. This is because the Dim level can not be set any higher than the current On level. So...if the On level (discussed previously) is set to 7, you would only be able to raise the Dim level to 7. If you want to use a higher value for the Dim level you will need to raise the value of the On level.

LED TIME MENU - The backlit keys on the SXRC have two intensity modes, On and Dim. This menu lets you select how long the SXRC waits when there is no button press activity before switching from the On level to the Dim level. The default is 90 seconds.



Use the **UP** and **DOWN** arrow keys to scroll through the available settings:
1 SEC (shortest delay) to **240 SEC**
 (longest delay)



Press the **ESC** key to save the setting and return to the DISPLAY menu.



NOTE:

This menu item works hand-in-hand with the LED ON LVL and LED DIM LVL menu items. Use this menu setting to determine how long your ISIS keys stay brightly lit after making your SXRC adjustments.

At this point you have explored all the settings in the DISPLAY menu. Press the **ESC** key to return to the SXRC SETUP menu.



AUTOSEARCH MENU - You should be familiar with this menu from the software updates we did earlier in the manual. The AUTOSEARCH function seeks out any amplifier connected to the SXRC Communications Network, updates the amplifier's software if required and loads it in to the SXRC.



If for any reason you lose an amplifier from the SXRC due to being un-plugged from the Communications Network, bad cable, etc. OR if you are adding a new amplifier to the SXRC you use this function.

Press the **ENT** key to activate the Autosearch function.



The SXRC will perform all of its steps (*highly detailed on page 18...attempting to save a forest here...go back and check it out there.*) and return to the SXRC SETUP menu.

GROUP AMPS MENU - Here you can create and customize amplifier groups in the SXRC. This is one of the most powerful and fun functions of the SXRC. Once you assign an amplifier to a group, it and all the other amplifiers in its' group can be adjusted in unison from the GROUP ADJ menu. All amplifiers in a group still maintain the ability to be adjusted individually in the AMP ADJ menu even when they are grouped...just what functions are accessible will vary based on the group setup.

The complete list of what functions can be controlled together (*GROUP ADJ*) or separately (*AMP ADJ*) are described in the LINK menu a little bit later in the manual.

The SXRC has 10 groups (*GROUP--01* through *GROUP--10*) for you to use. Each of these groups is capable of having up to 16 amplifiers assigned to it. No more than 16 amps total can be controlled by the SXRC. So if you have 16 amplifiers connected to the SXRC and you assign all 16 to Group-01, you can not create any more groups.

Some examples of why you would want to use grouping are:

Example 1

You have multiple amplifiers driving your subwoofer(s) and want to control all of them at the same time. Change a setting and have it changed in all of the amplifiers simultaneously.

Example 2

You have multiple amplifiers driving the front stage of your system (Midbass, Midrange and Tweeter) and you want to control them as a group.

Example 3

You have a 5.1 channel setup using multiple amplifiers to drive your front, center, rear and subwoofer setup. You want to create amplifier groups to control each section. Two amplifiers on front, two on center, two on rear and 4 on subwoofer.

Example 4

Our manual writer just experienced a combination of brain freeze and writer's block. Use your imagination and insert your own wild and crazy setup here for Example 4.

These are just a few of the many examples possible.

Here is a list of the menu items contained in the GROUP AMPS menu.

```

»GROUPS
»GROUP NAME
»ASSIGN
»RELEASE
»LINK
»REMOTE VOL
  
```

Use the **UP** and **DOWN** arrow keys to scroll through the available selections in the GROUP AMPS menu.

When you have the menu item selected that you want to view or adjust simply press the **ENT** key to select it.



GROUPS MENU - Here you can view the groups you have created and see which SX Series amplifiers have been assigned to each group.



If the display shows *N/A*, this means you do not have any groups created.

If you do have groups created then you will be able to scroll through the available groups using the **UP** and **DOWN** keys.



When you have the group selected that you want to view simply press the **ENT** key to select it.



You can now use the **UP** and **DOWN** keys to view each amplifier assigned to this group.



If you have multiple amps of the same make or name you can check its' Remote Address to help you identify which amp you are currently viewing. Simply press and hold the **ENT** key and the Remote Address of the amplifier will be displayed.



Press the **ESC** key to return to the list of available groups.



GROUP NAME MENU - Here you can change the default name of the 10 groups (*GROUP-01* to *GROUP-10*) to any 10 character name you want. Very useful for identifying a group of amps by their function or location.

Use the **UP** or **DOWN** keys to scroll through the available groups (*GROUP 1* through *GROUP 10*)



When you have the group selected that you want to name simply press the **ENT** key to select it.



You can now use the **ESC** and **ENT** keys to move the blinking cursor left or right to select which character you want to change.



Use the **UP** and **DOWN** keys to change the selected character. (*A B C ... 1 2 3 ...etc.*)



When you are finished press and hold the **HOME** key for 1.5 seconds to save your new group name.



You can now select another Group Name to change or press the **ESC** key to return to the SXRC SETUP menu.



ASSIGN MENU - Here you can select any of the 10 groups and select which amplifiers belong to that group.

An amplifier can only belong to ONE group at any time...so once you assign it to a group it can not be assigned to another group unless you remove it from the group it is currently assigned to. To remove an amplifier from a group you use the **RELEASE** menu function.

Use the **UP** or **DOWN** keys to select which group you want to assign amplifiers to and press the **ENT** key to select it.



If the display shows **N/A** then all amplifiers are currently assigned to a group. You have to use the **RELEASE** menu to free up the amplifier(s) you are wanting to use.



If there are amps available to assign then use the **UP** or **DOWN** keys to scroll through the list of available amplifiers.



If you have multiple amps of the same make or name you can check its' Remote Address to help you identify which amp you are currently viewing. Simply press and hold the **ENT** key and the Remote Address of the amplifier will be displayed.



Press **ENT** to add the selected amplifier to the current selected group.



The display will flash **ASSIGNED** to confirm the amplifier has been added. Once an amplifier is added to a group it is removed from the list of available amplifiers.



Continue assigning the amplifiers you want associated with this group by using the **UP** or **DOWN** keys to select the amp and the **ENT** key to select it.



When you are done assigning amplifiers to this group, press the **ESC** key to return to the **ASSIGN** menu's group selection screen. You can then select another group and assign amplifiers to it.



NOTE:

While selecting amplifiers to assign to a group, If you use up all the available amplifiers the display will read **N/A** letting you know there are no more amplifiers available to assign.



RELEASE MENU - Here you can remove any amplifier(s) from a group it is currently assigned to.

An amplifier can only belong to ONE group at any time...so if you wish to use an amplifier in a different group than the one it is currently assigned to, you have to release it from the current group. Here is where you can perform that precise surgical removal process. Don't touch the sides as you reach for the funny bone. BZZZ!

Use the **UP** or **DOWN** keys to select which group you want to release an amplifier(s) from and press the **ENT** key to select it.



If the display shows **N/A** then there are no amplifiers currently assigned to that group.



If there are amps assigned to the group then use the **UP** or **DOWN** keys to scroll through the list of amplifiers.



If you have multiple amps of the same make or name you can check its' Remote Address to help you identify which amp you are currently viewing. Simply press and hold the **ENT** key and the Remote Address of the amplifier will be displayed.



Press **ENT** to remove the selected amplifier from the current selected group.



The display will flash **RELEASED** to confirm the amplifier has been removed. Once an amplifier is removed from a group it is added back to the list of available amplifiers in the **ASSIGN** menu.



Continue releasing the amplifiers you want removed from this group by using the **UP** or **DOWN** keys to select the amp and the **ENT** key to select it.



When you are done releasing amplifiers from this group, press the **ESC** key to return to the **RELEASE** menu's group selection screen. You can then select another group to release amplifiers from.



NOTE:

While selecting amplifiers to remove from a group, if you remove all the amplifiers the display will read **N/A** letting you know there are no more amplifiers assigned to this group.



LINK MENU - Here you can set the Link property of the selected group to Link On or Link Off. By default all groups have the Link property set to Link Off.

The Link property sets a group to have certain characteristics depending on the setting (Link On or Link Off). By adjusting this one setting you completely change what settings and adjustments are shared between amplifiers in the group, what settings you can select to adjust in the AMP ADJ and GROUP ADJ menus and how certain settings act once they are selected. You have all ready seen an example of this in the GROUP ADJ menu when adjusting the Kompressor™.

Link Off - AMP ADJ

If you set the group's Link property to Link Off each amplifier in the group can have these items adjusted from the AMP ADJ menu.

```
» GAIN           » KOMPRESSOR
» EQ             » KOMP. ADJ
» LO-PASS       » GAIN RANGE
» HI-PASS       » BYPASS DSP
» PHASE         » PINK NOISE
» MUTE
```

Link Off - GROUP ADJ

If you set the group's Link property to Link Off each amplifier in the group can have these items adjusted from the GROUP ADJ menu.

```
» GAIN
» MUTE
» KOMPRESSOR
» PINK NOISE
```

Link On - AMP ADJ

If you set the group's Link property to Link On each amplifier in the group can have these items adjusted from the AMP ADJ menu.

```
» GAIN
» MUTE
```

Link On - GROUP ADJ

If you set the group's Link property to Link On each amplifier in the group can have these items adjusted from the GROUP ADJ menu.

```
» GAIN           » MUTE
» EQ             » KOMPRESSOR
» LO-PASS       » KOMP. ADJ
» HI-PASS       » GAIN RANGE
» PHASE         » PINK NOISE
```

Wow...things do change up quite a bit. But why? Glad you asked! The following two examples show why this happens and why the Link function exists...but we know there are many more.

Example 1

You have four SX.1 Series amplifiers driving four Solobaric L7 12 inchers. First off...you got game baby! Deep smooth bass for days...you could share some with the boys lounging around down at Local 317 and still have plenty! Ok...enough of that...here is one of the many reasons the Link function exists.

You would want to control all of these amplifiers together and share many settings between them the same since they are all on bass duty.

You would select a group and assign each of your four SX.1 Series amplifiers to this group. For this example we will assume you also changed the name of the group to BIG BASS.

Next select the BIG BASS group from the LINK menu and set its Link Property to Link On.

Now you would be able to set the gain range, gain, equalizer, low pass crossover, high pass crossover, Kompressor™, Kompressor™ Adjustment, etc. for all four amplifiers at the same time using the BIG BASS group you created. Each amplifier would share these important settings and you don't have to adjust four amplifiers, just adjust the BIG BASS group from the GROUP ADJ menu and that's it.

The only options you would be able to adjust from the AMP ADJ menu would be each amplifiers individual gain setting and mute function.

The gain setting allows you to level match each amplifier in the group independently in case one channel or amp needs to be tweaked to match the rest.

The mute function is for muting individual channels or entire amplifiers for setup and testing purposes.

Example 2

You have three SX.2 Series amplifiers driving the front stage of your audio system. One on tweeter duty, another on midrange and the last one on midbass.

You would want to control some of the functions of these amplifiers together but many you do not. Each amplifier needs its own unique crossover point to handle its required duties so Link On would not work.

You would select a group and assign each of your SX.2 Series amplifiers to this group. For our example we will assume this group has been named FRONTSTAGE.

Next select the FRONTSTAGE group from the LINK menu and set its Link Property to Link Off.

Now you would use the AMP ADJ menu to adjust each amplifier's gain range, gain, equalizer, low pass crossover, high pass crossover, Kompressor™, Kompressor™ Adjustment, etc. to fit its unique needs.

So why group them then? Because now you can use the GROUP ADJ menu to select FRONTSTAGE and be able to:

- »Adjust the overall output gain of all three amps together.
- »Turn their Kompressors™ on and off in unison.
- »Mute the entire front stage for setup and testing.
- »Use the pink noise generator on the entire front stage for setup and testing.

These are just two real world examples of how powerful grouping amplifiers can be and the flexibility it gives you when used in conjunction with the Link property. Use your imagination to come up with what works for you.

Once you select the *LINK* menu, a list of all 10 groups controlled by the SXRC will be displayed in a scrolling list. The list will either display the names you have created or the default names if you have not re-named them.



Use the **UP** or **DOWN** keys to scroll through the list of groups and press the **ENT** key to select.



Use the **UP** or **DOWN** keys to select *LINK ON* or *LINK OFF* for the group.



When done selecting the current group's Link property, press the **ESC** key to save the setting and return to the list of groups.



You can now select another group to view or adjust by using the **UP** or **DOWN** keys and select it by pushing the **ENT** key.



OR

Press the **ESC** key to return to the GROUP AMPS menu and select another function.



REMOTE VOL MENU - Here you can choose to have the selected group's output level controlled by the Digital Remote Volume Control (DRVC).

If you wish to use the DRVC as a master volume control, raising and lowering the output level of all the amplifiers, select all the groups and set to them *REMOTE ON*. By default, all groups are set to *REMOTE OFF*.

If you wish to use the DRVC as a bass level controller, raising and lowering the output level on subwoofer amplifiers only, set the REMOTE VOL to *REMOTE ON* for the group(s) controlling your subwoofer amplifiers and leave all other non-subwoofer groups set to *REMOTE OFF*.

These are the two most common uses. You can configure whatever combination works for your particular installation.

Use the **UP** or **DOWN** keys to scroll through the list of groups and press the **ENT** key to select.



Use the **UP** or **DOWN** keys to scroll through *REMOTE ON* and *REMOTE OFF*.



When done selecting the current group's Remote Vol setting, press the **ESC** key to save the setting and return to the list of groups.



You can now select another group to view or adjust by using the **UP** or **DOWN** keys and select it by pushing the **ENT** key.

OR

Press the **ESC** key to return to the GROUP AMPS menu and select another function.



SXRC NAME MENU - Here you can change the default name of the SXRC controller (**--SXRC--**) to any 10 character name you want. This is the name that scrolls in the DEFAULT menu.



Use the **ESC** and **ENT** keys to move the blinking cursor left or right to select which character you want to change.



Use the **UP** and **DOWN** keys to change the selected character. (**A B C ... 1 2 3 ...**etc.)



When you are finished press and hold the **HOME** key for 1.5 seconds to save your new SXRC name.



You are now back in the SXRC SETUP menu.

MEM NAME MENU - Here you can change the default name of each of the four global memories (*MEMORY--1* to *MEMORY--4*) to any 10 character name you want. Very useful for identifying a preset by its purpose (*SPL, SOUND Q, ROCK, RAP, etc.*).

Use the **UP** or **DOWN** keys to scroll through the available memories (*MEMORY--1* through *MEMORY--4*)



When you have the memory selected that you want to name simply press the **ENT** key to select it.

You can now use the **ESC** and **ENT** keys to move the blinking cursor left or right to select which character you want to change.

Use the **UP** and **DOWN** keys to change the selected character. (*A B C ... 1 2 3 ...etc.*)

When you are finished press and hold the **HOME** key for 1.5 seconds to save your new group name.

You can now select another Memory Name to re-name or press the **ESC** key to return to the SXRC SETUP menu.



AMP NAME MENU - Here you can change the default name of each SX Series amplifier (*SX--500/2*) to any 10 character name you want. Very useful for identifying an amplifier by its purpose (*BASS, CENTER, FRONT, REAR, etc.*).

Use the **UP** or **DOWN** keys to scroll through the amplifiers connected to the SXRC.



When you have the amplifier selected that you want to re-name simply press the **ENT** key to select it.

You can now use the **ESC** and **ENT** keys to move the blinking cursor left or right to select which character you want to change.

Use the **UP** and **DOWN** keys to change the selected character. (*A B C ... 1 2 3 ...etc.*)

When you are finished press and hold the **HOME** key for 1.5 seconds to save your new amplifier name.

You can now select another amplifier to re-name or press the **ESC** key to return to the SXRC SETUP menu.



SAVE ALL MENU - Here you can download the current SXRC settings for each amplifier into any one of the four SX Series amplifiers on-board memories. (MEM-1 through MEM-4)

This is useful for several purposes.

1.) You could have a preferred setup programmed into the SXRC and then simply plug it into the system and download all the settings into the amplifiers. Then un-plug the SXRC and the settings are now loaded into one of the amplifier's memory presets for use. Talk about a one-touch programming tool!

2.) You may want to disconnect your SXRC from the system and take it with you. By saving all the current settings in the SXRC to the amplifiers the system will operate without the SXRC but with the exact settings you were using.

3.) The 3-step-plan to sanity: Save, Save and Save. By saving your current settings from the SXRC into your amplifiers you have a backup of all your programming. If something should ever happen to your SXRC (Beverage spill, Sat on and crushed, girlfriend throws out the window at 60 MPH) you will have all your hard-earned system programming backed-up in your amplifiers. You could then follow the 3-step-plan to happiness: Remember, Remember, Remember. Simply plug in a new (or repaired) SXRC, perform an Autosearch, save the settings back into a global SXRC memory and your back in business.

Ain't technology just swell!

Once you are in the SAVE ALL menu you need to decide if you want to download the current settings in the SXRC or any one of the four SXRC global memories. If you want to download the current settings in use, skip the steps marked with a *

* Press any one of the four SXRC global memory presets to load it into the SXRC.



* The display will show *LOADING* while the global memory preset loads and then the display will show which preset is loaded and active.



Press the **ENT** key to enter the SAVE ALL memory location selection menu.



Use the **UP** or **DOWN** keys to scroll through the available memories (MEM-1 through MEM-4). This will be the memory preset the SXRC uses on each amplifier to store your settings.



When you have the memory selected that you want to use simply press the **ENT** key to select it.



The settings will be saved to the SX Series amplifiers and the display will return to *SAVE ALL*. You are now back in the SXRC SETUP menu.



LOCK CODE MENU - Here you can change the default security lock code used for the SXRC Security function. This code is used to unlock the SXRC after it has been locked to prevent un-authorized use. The default lock code is *123*.

Use the **ESC** and **ENT** keys to move the blinking cursor left or right to select which character you want to change.



Use the **UP** and **DOWN** keys to change the selected character. (*A B C ... 1 2 3 ...etc.*)



When you are finished press and hold the **HOME** key for 1.5 seconds to save your new security lock code.



You are now back in the SXRC SETUP menu.

NOTE:

Please write down your lock code and keep it in a safe place. If you lock the SXRC you will need this code to un-lock the unit. Without this code you will be very, very unhappy when at 1:00 am Friday night hanging out at BK Lounge you can't unlock your SXRC to show it off to your friends.

If you have lost your lock code you will have to chill until Monday morning, 8:00 am Central time, to ask a KICKER tech what magic he may be able to work for you. Be nice to him...it's Monday...It's early...he enjoys weekends too!

RESET SXRC MENU - Sometimes things just go wacky and the only way to fix things is to start fresh. Or perhaps you just want to start with a clean new slate. Either way, Ctrl-Alt-Delete works for Microsoft™...RESET SXRC works for us.

The SXRC is designed to handle the automotive electrical system and all its wonderful peculiarities but extreme low voltage conditions in your car, jump starting, voltage spikes, etc. could cause glitches or errors in your SXRC settings. If this ever happens here is where you can fix it.

Use the **UP** or **DOWN** arrow keys to select *SKIP RESET* or *DO RESET* and press the **ENT** key to select.



The SXRC will perform a complete reset back to factory defaults...

Then will search for all the amplifiers connected to it...

And will load all the amplifier settings back into the SXRC.

The SXRC will now ask you if you want to save the amplifier settings into a global memory preset in the SXRC. Use the **UP** or **DOWN** keys to select *SAVE - YES* or *SAVE - NO* and press the **ENT** key to select.



If you select *SAVE - NO* then the all of the connected amplifier's current settings are not stored into the SXRC. We recommend that you choose *SAVE - YES* and save them.

If you select *SAVE - YES* then you will choose which global memory location to store all of the connected amplifier's settings in by using the **UP** or **DOWN** key to scroll through the four memory locations. (*MEMORY-1* through *MEMORY-4*)



When the memory you want to use is selected press the **ENT** key to store.



The SXRC will respond by blinking *STORED* in the display to confirm the memory storing has completed successfully.



You are now back in the SXRC SETUP menu.

SW UPDATES MENU - This menu allows you to manually reload an SX Series amplifier with its operating software which is stored in the SXRC. The only time you would use this manual programming option is if:

- 1.) The operating software on an amplifier has been damaged or lost during normal operation.
- 2.) During the software update portion of the AUTOSEARCH function you experience a catastrophic failure. (Examples - More than one amp sharing the same Remote Address, Powering down an amplifier during software update, Communications Network failure)

You will know this has happened if:

- The ISIS display on the SX Series amplifier refuses to come back on.
- The ISIS display on the SX Series amplifier is filled with garbage characters.
- The SXRC ISIS display blinks *FAILED* and then scrolls *MANUAL SW UPDATE REQUIRED*.

NOTE:

This reload has to be performed with **ONLY** the amp you need to program plugged into the SXRC Interface Box. It is so important we will say it again...The **ONLY** amplifier plugged into the SXRC Interface Box is the one needing programmed. Please **READ** and **FOLLOW** the directions on how to perform this reload.

You will need to change some wiring on the Interface Box to perform this manual software upload.

The SXRC will have to be wired so it is on all the time. You do this by removing the remote turn-on wire from the Interface Box and using a short piece of wire to temporarily jumper the Remote Turn-On to the constant +12 volt.

The SX Series amplifier should have Power, Ground and Remote connected to it but be off at this point, no power on the Remote line. (System Off)

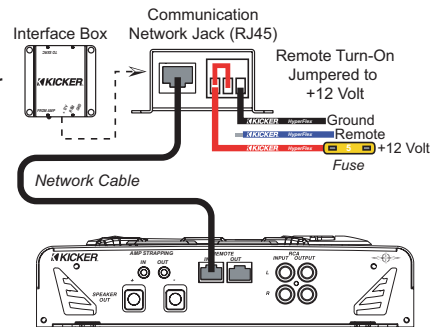

ABOUT MENU - The ABOUT menu displays information about the DAP (Digital Audio Processor) in your SXRC.

Use the **UP** or **DOWN** keys to view the model name, software version and software build date.



Press the **ESC** key to return to the SXRC SETUP menu.



SECURITY

SECURITY MENU - Want to keep your friends from adjusting your system to their tastes instead of yours? The SXRC lets you do it! Here you get to lock out the controls and prevent tampering with your system settings.

When the SXRC is locked down you will still see all of the DEFAULT menu items scrolling through the display, you can freeze and un-freeze the scrolling and you can adjust the Digital Remote Volume Control. These are the only controls accessible when the SXRC is locked.

Use the **UP** or **DOWN** arrow keys to scroll through the selections and press the **ENT** key to select.



DON'T LOCK does just that. It skips the entire locking function and returns to the MAIN menu.

LOCK SXRC locks out all the SXRC controls.

LOCK AMPS locks out the controls on all SX Series amplifiers connected to the SXRC. This prevents tampering at the amp directly unless you know the code.

LOCK ALL locks out all the SXRC controls and all SX Series amplifiers connected to the SXRC.

UNLOCK unlocks the controls on all SX Series amplifiers connected to the SXRC.

If you select any of the Lock functions, the SXRC will flash **LOCKED** in the display to verify the lock has completed successfully.



Once the SXRC is locked it will return to the DEFAULT menu and the **LOCK** indicator will be lit in the ISIS display.



From the DEFAULT menu press the **ENT** key to unlock the SXRC.



The display will show **UNLOCK**. Press the **ENT** key again to enter the UNLOCK menu and enter your code.



Use the **ESC** and **ENT** keys to move the blinking cursor left or right to select which character you want to change.



Use the **UP** and **DOWN** keys to change the selected character. (A B C ... 1 2 3 ...etc.)



When you are finished press and hold the **HOME** key for 1.5 seconds to enter your unlock code.



If the code is correct the SXRC will unlock and return to the MAIN menu. If this did not happen, then read on...

If you enter the wrong code the display will flash the message *BAD CODE* and return you to the UNLOCK menu.



Press the **ENT** key to enter your lock code again.



Enter your code again making sure to place the correct character in the correct position in the display. Blank spaces count as part of the code so be sure you are entering your code correctly.

If you have tried entering your code several times with no success (several is defined as more than 3...less than 10) then you probably have forgotten your lock code.

You will need to call KICKER directly at (405) 624-8583 and speak to a tech to handle this situation. You will need to have your amplifier's serial number AND your receipt by the phone as the guys and gals answering the phone will need this information from you to be of assistance.

Take the time right now to fill out the first page in this manual and staple your receipt to it. That way if you ever need service (like forgetting your lock code) you will have all the information you need right here with the manual.

NOTE:

The local ISIS keypads on all SX Series amplifiers are disabled once connected to the SXRC, their display will scroll *SXRC CTRL* to indicate this. If you disconnect the SXRC Control Head and power up the system, the local keypad at each amplifier will become active again. The LOCK AMPS menu item on the SXRC prevents the use of the amplifier's local keypad when the SXRC Control Head is disconnected ... unless you know the lock code.

If *LOCK AMPS* is activated, the *LOCK* indicator on all connected SX Series amplifiers will be turned on. If you use *UNLOCK*, the indicators will be turned off.

MEMORY PRESETS

There are four global memory presets built into the SXRC, each with its own indicator in the ISIS display and a dedicated memory key to activate it.

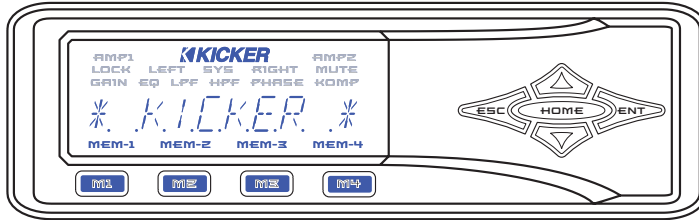

Each memory preset stores all the values shown at the right for each amplifier connected to the SXRC.

This gives you the ability to dial in four completely different system settings and store them in the memory presets for instant recall at any time.

STORING A PRESET

To store the current amplifier or group settings in the SXRC into a memory preset simply press and hold the desired memory key until the ISIS display flashes *STORED* and then release the memory key.

- » GAIN
- » EQ
- » LO-PASS
- » HI-PASS
- » PHASE
- » MUTE
- » KOMPRESSOR
- » KOMP. ADJ
- » REMOTE VOL



RECALLING A PRESET

To recall a memory preset simply press and release the desired memory key. The matching indicator in the ISIS display will light up and the SXRC will display *LOADING* while it loads all the settings stored in that preset into each SX Series amplifier.



KOMPRESSOR™

Powered by the on-board SX DAP (Digital Audio Processor), the Kompressor™ included in all SX Series amplifiers (and controlled by the SXRC) is a complete digital compressor solution used to compress or expand the audio signal in different ways based on the setting selected.

Using 'real world' testing in the automotive environment, KICKER engineers developed three compression/expansion settings for use in your SX Series amplifiers. Each setting controls 6 Kompressor™ parameters:

Compression Above Threshold - Controls how much expansion or compression is applied to the audio signal when its level is higher than the threshold.

Compression Below Threshold - Controls how much expansion or compression is applied to the audio signal when its level is lower than the threshold.

Threshold - This is the signal strength reference point that the Kompressor™ uses to determine when to compress or expand the signal.

Integration Time - Controls the energy detection part of the Kompressor™ circuitry and determines whether to look for peak output, averaged output or anything in between the two extremes.

Attack Time - Controls how quickly the Kompressor™ reacts to any signal above or below the threshold.

Release Time - Controls how quickly the Kompressor™ effect is released when any signal above or below the threshold is detected.

When you select one of the Kompressor™ presets (Contour, Red-Line or Attack) each of these 6 parameters is adjusted to provide the desired effect on the audio signal.

CONTOUR - This preset applies expansion below the threshold point to provide a fuller sound at lower volume levels. Effect decreases at higher volume levels. Nice effect for someone wanting a fuller sound at low to moderate listening levels.

ATTACK - This preset applies expansion above the threshold point to provide a nice quick punch or attack to the music. Effect increases with higher volume levels. Like music with a quick and punchy sound? Sub-bass need a little more snap to it? Give this one a try.

RED-LINE - Provides a quick clamp to dynamic peaks while still allowing a full sound to come through. Effect increases at higher volume levels. Like to play it loud but want to protect your speakers? Want low level details to come through over road noise? Want a more even volume level to your music? All can be achieved with this preset.

OFF - Pretty much says it all. This turns the Kompressor™ off. This is the factory default setting.

After selecting your Kompressor™ setting you can adjust the Threshold level through a 48 dB window (+24 dB to -24 dB from the default setting) by accessing the Kompressor™ Adjustment (KOMP ADJ.) setting located in the System menu. There you can change the threshold point to customize the Kompressor™ effect to fit your speakers, car or personal tastes.

A few words on the Kompressor™. The effect is most noticeable in the bass area of your music (Bass/Midbass). You can use the Kompressor™ in any amplifier configuration (Low Pass, High Pass, Band Pass or Full Range) but we feel the most dramatic results are obtained when the amp is in a Low Pass (subwoofer) or Band Pass (midbass) situation.

A few exceptions to this statement are:

The *RED-LINE* setting is good for use in any configuration as it helps control dynamic peaks and limit distortion at higher output levels. VERY effective at controlling speaker damaging distortion caused by over-driving or clipping the amplifier.

The *CONTOUR* setting is also another good all around use setting and when used in Full Range or High Pass configurations tends to enhance the vocal and top end of the music. Great for helping to cover up interior noise.

The *ATTACK* setting is really geared for bass and midbass duty but can be used in any setup.

Remember, these are just suggestions, play around with each Kompressor™ preset and the Threshold (KOMP ADJ) to find what works for you.

The possibilities are almost endless! ***Tweak away!***

SXRC SPECIFICATIONS

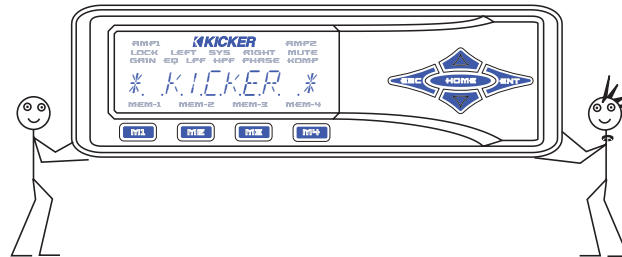

| | |
|---|---|
| Operating Voltage: | 9-16 volts DC |
| Remote Turn-On Voltage: | 9-16 volts DC |
| Internal Fusing in SXRC Interface Box: | Mini Glass Fast Blow 3 amp |
| Maximum Amplifiers: | 16 units |
| Maximum Groups: | 10 groups |
| DRVC Range: | 30 dB |
| Power, Ground, Remote Terminals: | Removable plug will accept up to 12 gauge wire. |
| Mounting Hardware: | Standard DIN 7-3/16 x 2-1/8 182mm x 53mm |

INTERFACE BOX FUSE

The SXRC is protected by a fuse which is internally mounted in the Interface Box. If you ever need to replace this fuse an extra one has been supplied with your SXRC kit. If you lose this fuse or ever need another one, please replace with the the same size and style of fuse.

To replace the fuse, first disconnect the power harness from the SX Interface Box.

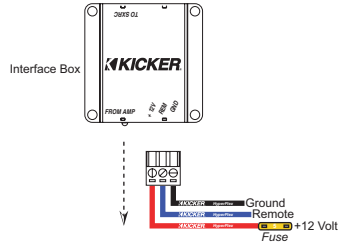

Next, remove the four screws holding the Interface Box to its mounting surface.

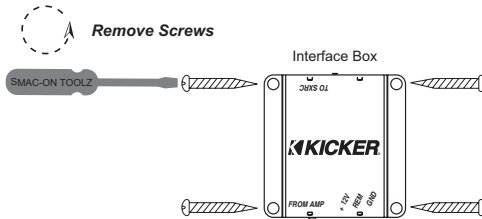

Now, remove the two screws on the side of the Interface Box which secure the top cover/mounting base to the bottom.

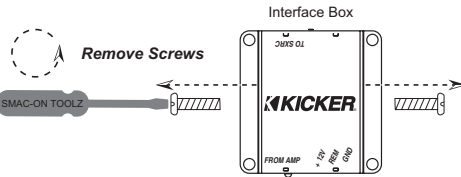

With the screws removed, carefully lift the top cover off the SX Interface Box.

With the top removed you can now see the 3 amp fuse held in place by two fuse clips.

Examine the fuse visually and see if it is blown and needs replaced.

Fuse Good



Fuse Blown



If blown, then gently pry the fuse up and away from the fuse clips using a small screwdriver.

Press in the new fuse until it locks fully into place.

You can now re-assemble the Interface Box following the above instructions in reverse.

NOTE:

Just a reminder that you should be very careful with the top cover removed from the Interface Box as to not damage any of the components inside. NEVER use a fuse with a higher rating than 3 amps. DO NOT connect the power harness to the Interface Box until it is fully assembled.

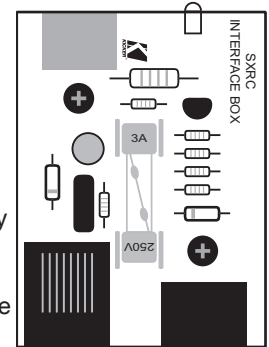
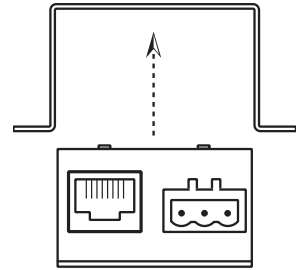

TROUBLESHOOTING

If your SXRC does not appear to be working, check obvious things first such as blown fuses, poor or incorrect wiring connections, cables and connectors not fully seated, etc.

There is a blue LED located on one end of the SXRC Interface Box. This LED indicates the SXRC is receiving power and is turned on.

○ Blue LED off:

- ⇨ Verify the external fuse to the Interface Box is good.
- ⇨ Verify the power plug is fully seated in the Interface Box.
- ⇨ Verify the wiring is correct at the power plug.
- ⇨ With a Volt Ohm Meter's (VOM) negative probe attached to chassis ground check:
 - +12 volt power terminal (should read +12V to +16V)
 - Remote turn-on terminal (should read +12V to +16V)
 - Ground terminal (should read 0V)
- ⇨ Verify the internal fuse in the Interface Box is good.

○ Blue LED on, no display on SXRC Control Head:

- ⇨ Verify the cable from the Control Head is plugged securely into the Interface Box.
- ⇨ If using an extension cable between the Interface Box and the Control Head, Verify the connectors are plugged in securely on both ends.
- ⇨ If using an extension cable between the Interface Box and the Control Head, Verify the cable is a 6 conductor PS2 type cable.
- ⇨ If using an extension cable between the Interface Box and the Control Head, the cable or connectors on it may be bad, try bypassing the extension cable and plugging the Control Head directly into the Interface Box. If this works, then try a new cable.

○ Blue LED on, garbage characters in display:

- ⇨ Power cycle your system (turn off, wait 3 seconds, turn on).
- ⇨ Reset the SXRC form the SXRC SETUP menu.
- ⇨ Verify all cables are securely plugged into the Interface Box.
- ⇨ Verify all Network Cables are securely plugged in at the Interface Box and SX Series amplifiers.
- ⇨ Verify all Network cables are good. If you made these cables check that they are properly wired and terminated.

○ Blue LED on, STARTING * displayed for a long time, amplifiers not responding:

- ⇨ Does SX Series amplifier(s) scroll *SXRC ETL* in display?
 - ✓ If not, then that amplifier is not connected or communicating to the SXRC.
- ⇨ Go back and double check your Communications Network cables and make sure they are inserted properly and 'snapped' into place.
- ⇨ If you have purchased different cables, double check that they are Straight-Through Ethernet Network cables.
- ⇨ If you have made your own cables double check them for secure and proper termination.
- ⇨ Check the pins (#1 and #8) in the SX Series amplifiers to make sure they are not bent or damaged.
- ⇨ Power cycle your system (turn off, wait 3 seconds, turn on).
- ⇨ Reset the SXRC form the SXRC SETUP menu.

○ Blue LED on, SXRC display ok, SX Series amplifiers on, garbage characters in SX Series amplifier display, blank SX Series amplifier display:

- ⇨ Power cycle your system (turn off, wait 3 seconds, turn on).
- ⇨ Perform a Manual Software Update for each amplifier exhibiting problem.
- ⇨ Reset the SXRC form the SXRC SETUP menu.

○ **SXRC displays FAILED and MANUAL SW UPDATES REQUIRED:**

- ↗ Autosearch function has failed due to a catastrophic failure, loss of communication network, loss of power during software update.
 - ✓ Go back and double check your Communications Network cables and make sure they are inserted properly and 'snapped' into place.
 - ✓ If you have purchased different cables, double check that they are Straight-Through Ethernet Network cables.
 - ✓ If you have made your own cables double check them for secure and proper termination.
 - ✓ Check the pins (#1 and #8) in the SX Series amplifiers to make sure they are not bent or damaged.
- ↗ Perform a Manual Software Update for each amplifier exhibiting problem.

○ **Everything powers up and looks great, just no sound:**

- ↗ Is the *MUTE* indicator blinking in the SXRC display?. Turn off mute for all amplifiers.
- ↗ Use the Pink Noise function to test system for audio output. The pink noise function injects its signal directly into the amplifier after the DSP processor. This helps to determine if the problem is before the DSP and amplifier or after.
 - ✓ If you have pink noise from all your speakers then check your :
 - Gain Range settings.
 - Gain settings.
 - Crossover settings.
 - RCA cables and connections.
 - Head unit fader, balance and volume controls.

- ✓ If you don't have pink noise from all your speakers then check your :
 - Speakers.
 - Speaker cables and connections.
 - Amplifier power and speaker connections.

○ **All of my amplifier's volumes vary when I use the DRVC (Remote Volume Control). I just want to control my bass!:**

- ↗ By default, all amplifiers connected to the SXRC are controlled by the DRVC. Turn the *REMOTE VOL* function off for all amplifiers not connected to your subwoofers.
 - Select appropriate amp through *AMP ADJ* menu.

OR

- Select appropriate group through *GROUP ADJ* menu.

THEN

- Select *REMOTE VOL*.
- Select *OFF*.

○ **Other problem, I am lost, I don't know, Help!:**

- ↗ Contact your local Authorized KICKER Dealer where you purchased your unit for assistance.
- ↗ Contact KICKER Technical Services for assistance.
- ↗ Ctrl+Alt+Del.

CAUTION: When jump starting the vehicle, be sure that connections made with the jumper cables are correct. Improper connections (+ to - & - to +) will result in blown fuses as well as failure to other systems in the vehicle.

If you have questions about the installation and operation of your new KICKER SXRC Remote Control, see the Authorized KICKER Dealer in your area or contact KICKER Technical Services directly at (405)624-8583.

REMOTE ADDRESS CHART

Use this fill-in-the-blank chart to keep track of your SX Series amplifier's remote address and name. This is very helpful for setting up your SXRC.

| Amplifier | Remote Address | Name |
|--------------|----------------|-------|
| Amplifier 1 | _____ | _____ |
| Amplifier 2 | _____ | _____ |
| Amplifier 3 | _____ | _____ |
| Amplifier 4 | _____ | _____ |
| Amplifier 5 | _____ | _____ |
| Amplifier 6 | _____ | _____ |
| Amplifier 7 | _____ | _____ |
| Amplifier 8 | _____ | _____ |
| Amplifier 9 | _____ | _____ |
| Amplifier 10 | _____ | _____ |
| Amplifier 11 | _____ | _____ |
| Amplifier 12 | _____ | _____ |
| Amplifier 13 | _____ | _____ |
| Amplifier 14 | _____ | _____ |
| Amplifier 15 | _____ | _____ |
| Amplifier 16 | _____ | _____ |

SPAIR

It is going to happen, you will change your mind or change your system. Here is a backup chart. Photocopy this page and you can have all the charts you need.

| Amplifier | Remote Address | Name |
|--------------|----------------|-------|
| Amplifier 1 | _____ | _____ |
| Amplifier 2 | _____ | _____ |
| Amplifier 3 | _____ | _____ |
| Amplifier 4 | _____ | _____ |
| Amplifier 5 | _____ | _____ |
| Amplifier 6 | _____ | _____ |
| Amplifier 7 | _____ | _____ |
| Amplifier 8 | _____ | _____ |
| Amplifier 9 | _____ | _____ |
| Amplifier 10 | _____ | _____ |
| Amplifier 11 | _____ | _____ |
| Amplifier 12 | _____ | _____ |
| Amplifier 13 | _____ | _____ |
| Amplifier 14 | _____ | _____ |
| Amplifier 15 | _____ | _____ |
| Amplifier 16 | _____ | _____ |

ELECTRONICS LIMITED WARRANTY

Kicker warrants this product to be free from defects in material and workmanship under normal use for a period of **THREE (3) MONTHS** from date of original purchase with receipt. When purchased from a Authorized KICKER Dealer it is warranted for **TWO (2) YEARS** from date of original purchase with receipt. In all cases you **must have the original receipt!** Should service be necessary under this warranty for any reason due to manufacturing defect or malfunction during the warranty period, Kicker will repair or replace (at its discretion) the defective merchandise with equivalent merchandise at no charge. Warranty replacements may have cosmetic scratches and blemishes. Discontinued products may be replaced with more current equivalent products.

This warranty is valid only for the **original purchaser** and is not extended to owners of the product subsequent to the original purchaser. Any applicable implied warranties are limited in duration to a period of the express warranty as provided herein beginning with the date of the original purchase at retail, and no warranties, whether express or implied, shall apply to this product thereafter. Some states do not allow limitations on implied warranties, therefore these exclusions may not apply to you.

This warranty gives you specific legal rights; however you may have other rights that vary from state to state.

WHAT TO DO IF YOU NEED WARRANTY OR SERVICE

Defective merchandise should be returned to your local Authorized Stillwater Designs (Kicker) Dealer for warranty. Assistance in locating an Authorized Dealer can be found at www.kicker.com or by contacting Stillwater Designs directly. You can confirm that a dealer is authorized by asking to see a current authorized dealer window decal.

If it becomes necessary for you to return defective merchandise directly to Stillwater Designs (Kicker), call the Kicker Customer Service Department at (405)624-8510 for a Return Authorization (RMA) number. Package all defective items in the original container or in a package that will prevent shipping damage, and return to

Stillwater Designs, 5021 North Perkins Road, Stillwater, OK 74075

The RMA number must be clearly marked on the outside of the package. Return **only defective components**. Return of entire cabinets, system packs, pairs, etc. increases your return freight charges. Non-defective items received will be returned freight collect.

Include a **"proof-of-purchase"** statement! This would be a copy of the original receipt with the Purchase date clearly visible, Customer's name, Dealer's name, Invoice number and Product purchased. Warranty expiration on items without a proper **proof-of-purchase** will be determined from type of sale and the manufacturing date code. Freight must be prepaid; items received freight collect will be refused.

Failure to follow these steps may void your warranty. Any questions can be directed to the Kicker Customer Service Department at (405)624-8510.

WHAT IS NOT COVERED?

This warranty is valid only if the product is used for the purpose for which it was designed.

It does not cover:

- Damage due to improper installation.
- Subsequent damage to other components.
- Damage caused by exposure to moisture, excessive heat, chemical cleaners, and/or UV radiation.
- Damage through negligence, misuse, accident or abuse. Repeated returns for the same damage may be considered abuse.
- Any cost or expense related to the removal or reinstallation of product.
- Speakers damaged due to amplifier clipping or distortion.
- Items previously repaired or modified by any unauthorized repair facility.
- Return shipping on non-defective items.
- Products with tampered or missing barcode labels.
- Products returned without a Return Authorization (RMA) number.
- Freight Damage.
- The cost of shipping product to Kicker.
- Service performed by anyone other than Kicker.

HOW LONG WILL IT TAKE?

Kicker strives to maintain a goal of 72-hour service for all electronics (amps, crossovers, eq, etc.) returns. Delays may be incurred if lack of replacement inventory or parts is encountered.

INTERNATIONAL WARRANTY

Contact your International Kicker dealer or distributor concerning specific procedures for your country's warranty policies.

STILLWATER
Designs®

P.O. Box 459 • Stillwater, Oklahoma 74076 • U.S.A. • 405 624-8510

WARNING:

KICKER drivers are capable of producing sound levels that can permanently damage your hearing! Turning up a system to a level that has audible distortion is more damaging to your ears than listening to an undistorted system at the same volume level. The threshold of pain is always an indicator that the sound level is too loud and may permanently damage your hearing.
Please use common sense when controlling volume!

Today's System Diagram

Tomorrow's System Diagram

NOTES

MY FUTURE 'DROOL' SYSTEM

CASH MONEY PLAN



Free Manuals Download Website

<http://myh66.com>

<http://usermanuals.us>

<http://www.somanuals.com>

<http://www.4manuals.cc>

<http://www.manual-lib.com>

<http://www.404manual.com>

<http://www.luxmanual.com>

<http://aubethermostatmanual.com>

Golf course search by state

<http://golfingnear.com>

Email search by domain

<http://emailbydomain.com>

Auto manuals search

<http://auto.somanuals.com>

TV manuals search

<http://tv.somanuals.com>