



PROTECTOR® SERIES GAS FRYERS

Service & Parts Manual



Frymaster, a member of the Commercial Food Equipment Service Association, recommends using CFESA Certified Technicians.

24-Hour Service Hotline 1-800-551-8633

FEBRUARY 2009

* 8196345 *

www.frymaster.com

E-mail: service@frymaster.com

NOTICE

IF, DURING THE WARRANTY PERIOD, THE CUSTOMER USES A PART FOR THIS MANITOWOC FOOD SERVICE EQUIPMENT OTHER THAN AN **UNMODIFIED** NEW OR RECYCLED PART PURCHASED DIRECTLY FROM FRYMASTER DEAN, OR ANY OF ITS AUTHORIZED SERVICE CENTERS, AND/OR THE PART BEING USED IS MODIFIED FROM ITS ORIGINAL CONFIGURATION, THIS WARRANTY WILL BE VOID. FURTHER, FRYMASTER DEAN AND ITS AFFILIATES WILL NOT BE LIABLE FOR ANY CLAIMS, DAMAGES OR EXPENSES INCURRED BY THE CUSTOMER WHICH ARISE DIRECTLY OR INDIRECTLY, IN WHOLE OR IN PART, DUE TO THE INSTALLATION OF ANY MODIFIED PART AND/OR PART RECEIVED FROM AN UNAUTHORIZED SERVICE CENTER.

NOTICE

This appliance is intended for professional use only and is to be operated by qualified personnel only. A Frymaster DEAN Factory Authorized Service Center (FASC) or other qualified professional should perform installation, maintenance, and repairs. Installation, maintenance, or repairs by unqualified personnel may void the manufacturer's warranty. See Chapter 1 of this manual for definitions of qualified personnel.

NOTICE

This equipment must be installed in accordance with the appropriate national and local codes of the country and/or region in which the appliance is installed. See **NATIONAL CODE REQUIREMENTS** in Chapter 2 of this manual for specifics.

NOTICE TO U.S. CUSTOMERS

This equipment is to be installed in compliance with the basic plumbing code of the Building Officials and Code Administrators International, Inc. (BOCA) and the Food Service Sanitation Manual of the U.S. Food and Drug Administration.

NOTICE

Drawings and photos used in this manual are intended to illustrate operational, cleaning and technical procedures and may not conform to onsite management operational procedures.

NOTICE TO OWNERS OF UNITS EQUIPPED WITH COMPUTERS

U.S.

This device complies with Part 15 of the FCC rules. Operation is subject to the following two conditions: 1) This device may not cause harmful interference, and 2) This device must accept any interference received, including interference that may cause undesired operation. While this device is a verified Class A device, it has been shown to meet the Class B limits.

CANADA

This digital apparatus does not exceed the Class A or B limits for radio noise emissions as set out by the ICES-003 standard of the Canadian Department of Communications.

Cet appareil numérique n'émet pas de bruits radioélectriques dépassant les limites de classe A et B prescrites dans la norme NMB-003 édictée par le Ministre des Communications du Canada.

DANGER

Improper installation, adjustment, maintenance or service, and unauthorized alterations or modifications can cause property damage, injury, or death. Read the installation, operating, and service instructions thoroughly before installing or servicing this equipment. Only qualified service personnel may convert this appliance to use a gas other than that for which it was originally configured.

⚠ DANGER

No structural material on the fryer should be altered or removed to accommodate placement of the fryer under a hood. Questions? Call the Frymaster Dean Service Hotline at 1-800-551-8633.

⚠ DANGER

Adequate means must be provided to limit the movement of this appliance without depending upon the gas line connection. Single fryers equipped with legs must be stabilized by installing anchor straps. All fryers equipped with casters must be stabilized by installing restraining chains. If a flexible gas line is used, an additional restraining cable must be connected at all times when the fryer is in use.

⚠ DANGER

The front ledge of the fryer is not a step! Do not stand on the fryer. Serious injury can result from slips or contact with the hot oil.

⚠ DANGER

Do not store or use gasoline or other flammable liquids or vapors in the vicinity of this or any other appliance.

⚠ DANGER

Instructions to be followed in the event the operator smells gas or otherwise detects a gas leak must be posted in a prominent location. This information can be obtained from the local gas company or gas supplier.

⚠ DANGER

This product contains chemicals known to the state of California to cause cancer and/or birth defects or other reproductive harm.

Operation, installation, and servicing of this product could expose you to airborne particles of glasswool or ceramic fibers, crystalline silica, and/or carbon monoxide. Inhalation of airborne particles of glasswool or ceramic fibers is known to the State of California to cause cancer. Inhalation of carbon monoxide is known to the State of California to cause birth defects or other reproductive harm.

⚠ DANGER

The crumb tray in fryers equipped with a filter system must be emptied into a fireproof container at the end of frying operations each day. Some food particles can spontaneously combust if left soaking in certain shortening material.

⚠ WARNING

Do not bang fry baskets or other utensils on the fryer's joiner strip. The strip is present to seal the joint between the fry vessels. Banging fry baskets on the strip to dislodge shortening will distort the strip, adversely affecting its fit. It is designed for a tight fit and should only be removed for cleaning.

NOTICE

The Commonwealth of Massachusetts requires any and all gas products to be installed by a licensed plumber or pipe fitter.

PROTECTOR[®] SERIES GAS FRYERS

TABLE OF CONTENTS

CAUTIONARY STATEMENTS	i
CHAPTER 1: Service Procedures	
1.1 Functional Description	1-1
1.2 The Electronic Ignition System.....	1-1
1.3 Interface Board	1-2
1.4 Thermostats	1-4
1.5 Accessing Fryers for Servicing	1-4
1.6 Cleaning the Gas Valve Vent Tube.....	1-5
1.7 Checking the Burner Manifold Gas Pressure.....	1-5
1.8 Measuring Flame Current.....	1-7
1.9 Replacing Fryer Components.....	1-7
1.9.1 Replacing the Controller or the Controller Wiring Harness.....	1-7
1.9.2 Replacing the Temperature Probe or High-Limit Thermostat	1-8
1.9.3 Replacing the Interface Board.....	1-8
1.9.4 Replacing an Ignition Module.....	1-9
1.9.5 Replacing an Ignitor Assembly	1-9
1.9.6 Replacing or Cleaning a Combustion Air Blower.....	1-10
1.9.7 Adjusting the Air/Gas Mixture.....	1-11
1.9.8 Replacing a Gas Valve	1-12
1.9.9 Replacing a Burner Assembly.....	1-13
1.9.10 Replacing the Filter Motor, Filter Pump, or Filter Pump Solenoid Valve	1-14
1.9.11 Replacing the Frypot	1-14
1.9.12 Replacing Frypot Insulation and/or Upper Burner Rails.....	1-16
1.10 Troubleshooting and Problem Isolation	1-19
1.10.1 Ignition Failure	1-19
1.10.2 Improper Burner Function.....	1-20
1.10.3 Improper Temperature Control	1-21
1.10.4 Computer Malfunctions.....	1-22
1.10.5 Filtration Malfunctions.....	1-22
1.10.6 Leakage	1-24
1.10.7 Basket Lift Malfunctions.....	1-24
1.11 Troubleshooting Guides	1-26
1.11.1 Troubleshooting the 24 VAC Circuit	1-26
1.11.2 Troubleshooting the Gas Valve.....	1-28
1.11.3 Troubleshooting the Temperature Probe.....	1-28
1.12 Probe Resistance Chart.....	1-29
1.13 ATO (Automatic Top-Off) Service Procedures	1-29
1.13.1 ATO (Automatic Top-Off Troubleshooting.....	1-30
1.13.2 ATO (Automatic Top-Off) Board Positions and Harnesses	1-31
1.13.3 Replacing the ATO Board or Transformer.....	1-32
1.13.4 Replacing the ATO Pump or Solenoid.....	1-32
1.14 CM7 Computer Service Procedures	1-32
1.14.1 CM7 Computer Troubleshooting	1-32
1.14.2 CM7 Useful Codes and Passwords	1-35
1.14.3 CM7 Menu Summary Tree.....	1-36
1.14.4 CM7 Board Pin Positions and Harnesses	1-37

PROTECTOR® SERIES GAS FRYERS

TABLE OF CONTENTS cont.

1.15	Loading and Updating Software Procedures.....	1-38
1.16	Principal Wiring Connections	1-39
1.17	Wiring Diagrams	1-40
1.17.1	Main Wiring	1-40
1.17.2	Transformer / Filter Boxes	1-41
1.17.2.1	FPGL230 and 430 Transformer/Filter Box (Domestic)	1-41
1.17.2.2	FPGL330 Transformer/Filter Box (Domestic).....	1-42
1.17.3	Modular Basket Lift (100/120V).....	1-43
1.17.4	Modular Basket Lift (208/250V).....	1-44
1.18	Simplified Wiring Diagrams	1-45
1.18.1	FPGL30 Full-Vat Dual-Spark Module	1-45
1.18.2	FPGL30 Full-Vat Single-Spark Module (Australia & Pacific Rim).....	1-46
1.18.3	FPGL30 Series Simplified Wiring	1-47
1.18.4	FPGL30 Series Data Network Flowchart.....	1-48

CHAPTER 2: Parts List

2.1	Accessories.....	2-1
2.2	Basket Lift Assemblies and Associated Parts	2-2
2.3	Doors, Sides, Flue Caps, Top Caps and Casters	2-4
2.4	Drain System Components.....	2-5
2.4.1	Drain Valves and Associated Parts	2-5
2.4.2	Drain Tube Sections and Associated Parts.....	2-6
2.5	Electronics and Electrical Components.....	2-7
2.5.1	Component Boxes	2-7
2.5.2	Transformer Boxes	2-9
2.5.3	Computers and Associated Components.....	2-11
2.6	Wiring.....	2-12
2.6.1	Main Wiring Harnesses	2-12
2.6.2	CM7 and ATO Wiring Harnesses	2-13
2.7	Frypots and Associated Components	2-14
2.7.1	Full-Vat Frypot Components.....	2-14
2.7.2	Frypot Assemblies and Associated Parts.....	2-16
2.8	Gas Supply and Combustion System Components	2-17
2.9	Gas Valves and Associated Components	2-19
2.10	Filtration System Components	2-21
2.11	Return Valve Assembly and Associated Parts	2-23
2.12	ATO (Auto Top-Off) Components.....	2-24
2.12.1	JIB (Jug In Box) Low Indicator Light Assembly	2-24
2.12.2	ATO (Automatic Top-Off) Board	2-24
2.12.3	ATO (Automatic Top-Off) Solenoid and Pump Assemblies	2-25
2.12.4	JIB Cradle, JIB/BIB Cap and Pick Up Assemblies.....	2-25
2.13	Wiring Connectors, Pin Terminals, and Tools	2-26
2.14	Fasteners.....	2-27

THIS PAGE INTENTIONALLY LEFT BLANK

PROTECTOR® SERIES GAS FRYER

CHAPTER 1: SERVICE PROCEDURES

1.1 Functional Description

Protector® series gas fryers contain a welded stainless steel frypot that is directly heated by a high efficiency infrared burner system, requiring approximately 43% less energy than conventional burners to cook the same volume.

Self-contained combustion chambers (referred to as “burners”) are fitted into rails attached to the sides of the frypot, one on each side. Each combustion chamber is fitted with special ceramic tiles that are heated by the burning of a forced air/gas mixture. The tiles transfer heat to the frypot by means of infrared radiation, providing much more constant and uniform heat dispersion over the surface of the frypot than do conventional burners. Because less heat is lost to the atmosphere in the process, compared to “open-burner” designs, less fuel is required to achieve and maintain a given frypot temperature.

In full-vat units, gas flow to both of the burners is regulated by one electromechanical gas valve. All fryers in this series are equipped with 24 VAC gas valve systems, and all are configured with electronic ignition.

1.2 The Electronic Ignition System

An ignition module mounted in the component box (located behind the control panel) is connected to an ignitor assembly at the burner. The ignition module performs four important functions: it provides fuse protection for the 24-volt circuit, provides an ignition spark, supplies voltage to the gas valve, and proofs the burner flame. The module contains a four second time delay circuit and a coil that activates the gas valve. Three types are in use. A closed-box design is used in most fryers, but in some fryers built for export, the module resembles an interface board. A single dual-spark module is used on current production full-vat fryers.

The ignitor assembly consists of a spark plug, an enrichment tube, and a flame sensor.

At start-up, the power switch is placed in the ON position, supplying approximately 12-volts DC to the heat-control circuitry in the computer and to one side of the heat relay coils on the interface board. If resistance in the temperature probe indicates the temperature in the frypot is below 180°F (82°C), the current flows through a melt cycle circuit where a timer switch alternately closes for six seconds and opens for 24 seconds. If the temperature is 180°F (82°C) or above, the current flows through a heat circuit, bypassing the timer switch. In either case, ground is supplied to the other leg of the heat relay coils, which closes electronic switches in the 24 VAC circuit to provide current to the ignition module. Circuitry in the ignition module sends 24 VAC to the gas valve via a normally closed high-limit switch and a normally closed drain safety switch. Simultaneously, the module causes the ignitor to spark for four seconds to light the burner. A flame sensor verifies the burner

Inside the Ignition Module

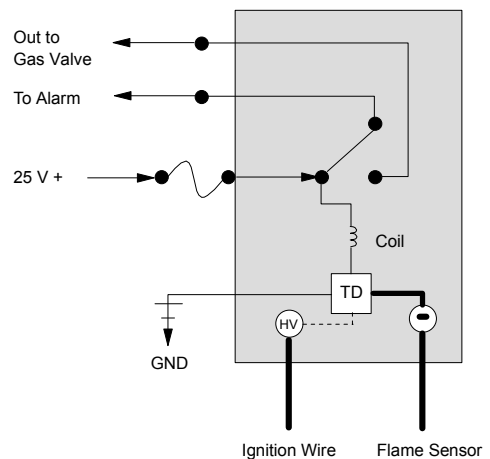

ignition by measuring the flow of microamps through the flame. If the burner does not light (or is extinguished), current to the ignition module is cut, the gas valve closes, and the ignition module “locks out” until the power switch is turned off and then back on. A probe monitors the temperature in the frypot. When the programmed setpoint temperature is reached, resistance in the probe causes the heat cycle circuitry in the computer to cut off current flow through the heat relay. This in turn cuts off the 24 VAC to the ignition module, causing the gas valve to close.

1.3 Interface Board

All fryers in this series have an interface board located in the component box behind the control panel. The interface board provides a link between the computer and the fryer’s individual components without requiring excessive wiring, and allows the computer to execute commands from one central point.

K2 and K3 are double-pole-double throw (DPDT) relays that supply 24VAC to the ignition and gas valve circuits, as well as 120VAC to the blower motor. The relays on this board plug into sockets. If a relay fails, that relay can be replaced.

LEDs (labeled D1 through D7) are arrayed around the board to assist in troubleshooting.

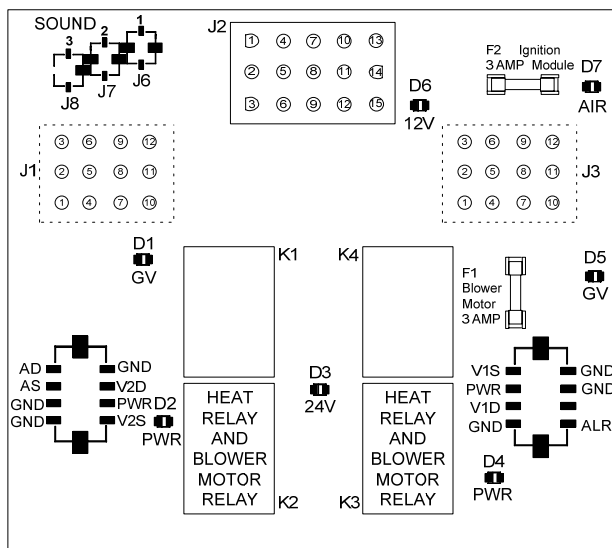

SMT INTERFACE BOARD KIT 826-2264 (106-6706)

INTERFACE BOARD LED DIAGNOSTIC LIGHTS	
D1	24 VAC to left gas valve (dual vat only)
D2	24 VAC to left ignition module (dual vat only)
D3	24 VAC from transformer
D4	24 VAC to right ignition module
D5	24 VAC to gas valve (right valve if dual vat)
D6	12 VAC from transformer
D7	CE and Japanese units only: air switch closed

NOTE: In full-vat fryers, the relay for the left side (K2) may not be present.

The chart on the following page illustrates current flow through the board, and the table at the top of page 1-4 identifies frequently used test points.

INTERFACE BOARD

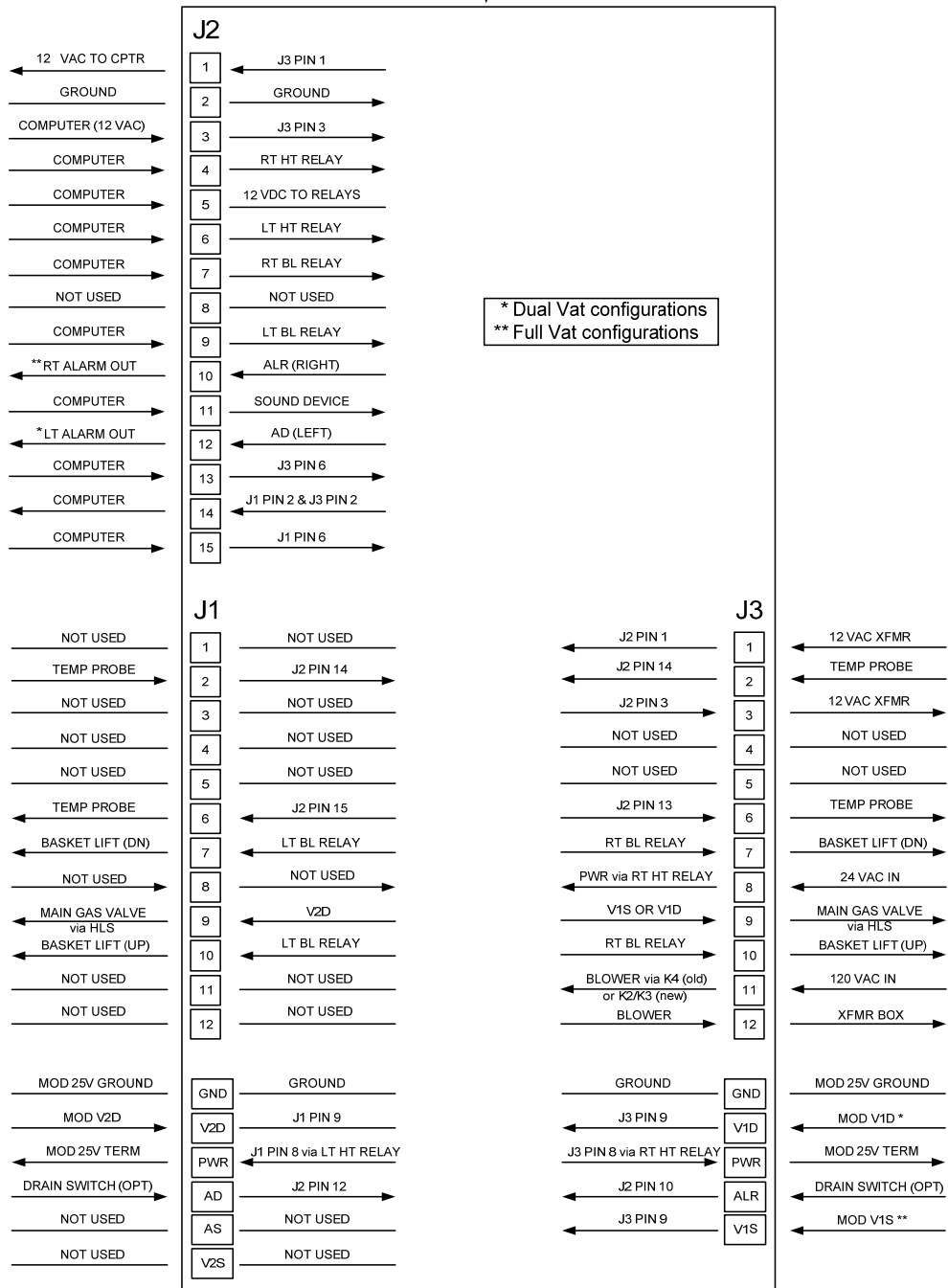

LEFT VAT

FULL OR RIGHT VAT

CURRENT FLOW THROUGH INTERFACE BOARD 106-6706 (SMT HE SERIES APPLICATION)

FREQUENTLY USED TEST POINTS FOR INTERFACE BOARD 106-6706			
Test	Meter Setting	Pins	Results
12VAC Power to Controller	50VAC Scale	1 and 3 on J3 or J2	12-18
24VAC Power to Right Module	50VAC Scale	8 on J3 and GROUND	22-28
120 VAC Power	250VAC Scale	11 on J3 and GROUND	110-125
120 VAC Power to Blowers	250VAC Scale	12 on J3 and GROUND	110-125
24VAC Power to Full Vat High-Limit	50VAC Scale	9 on J3 and GROUND	22-28
Probe Resistance (Full Vat) *	R x 1000 OHMS	2 and 6 on J3 or 13 and 14 on J2	**
Probe Isolation	R x 1000 OHMS	6 on J1 or J3 and GROUND	***
High-Limit Continuity (Full Vat)	R x 1 OHM	9 on J3 and Wire 13C on Gas Valve	0
* Disconnect 20-pin harness from controller before testing probe circuit.			
** See Probe Resistance Chart at end of chapter.			
*** 5 mega-Ohms or greater.			

1.4 Thermostats

Protector[®] series gas fryers have *temperature probes* located on the front centerline of each frypot. In this type of thermostat, the probe resistance varies directly with the temperature. That is, as the temperature rises, so does resistance, at a rate of approximately 2 ohms for every 1° F. Circuitry in the computer monitors the probe resistance and controls burner firing when the resistance exceeds or falls below programmed temperatures (setpoints).

Protector[®] series gas fryers are also equipped with a *high-limit thermostat*. In the event that the fryer fails to properly control the oil temperature, the high-limit thermostat prevents the fryer from overheating to the flash point. The high-limit thermostat acts as a normally closed power switch that opens when exposed to temperatures above 425°F to 450°F (218°C to 232°C). The different types of thermostats have different part numbers for CE and Non-CE models, and are not interchangeable.

1.5 Accessing Fryers for Servicing

DANGER

Moving a fryer filled with oil may cause spilling or splattering of the hot liquid. Follow the draining instructions in Chapter 5 of the Protector[®] Series Gas Fryer Installation and Operation Manual (P/N 819-6339) before attempting to relocate a fryer for servicing.

1. Shut off the gas supply to the unit. Unplug the power cords. Disconnect the unit from the gas supply.
2. Remove any attached restraining devices and relocate the fryer for service accessibility.
3. After servicing is complete, reconnect the unit to the gas supply, reattach restraining devices, and plug in the electrical cords.

1.6 Cleaning the Gas Valve Vent Tube

1. Set the fryer power switch and the gas valve to the OFF position.
2. Carefully unscrew the vent tube from the gas valve. **NOTE:** The vent tube may be straightened for ease of removal.
3. Pass a piece of ordinary binding wire (.052 inch diameter) through the tube to remove any obstruction.
4. Remove the wire and blow through the tube to ensure it is clear.
5. Reinstall the tube and bend it so that the opening is pointing downward.

1.7 Checking the Burner Manifold Gas Pressure

1. **On non-CE fryers only** ensure that the gas valve knob is in the OFF position.

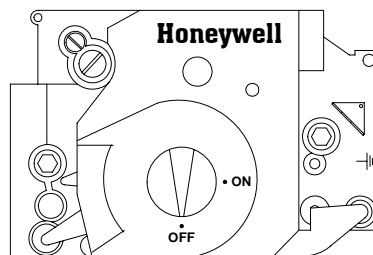

2. Remove the pressure tap plug from the gas valve assembly.

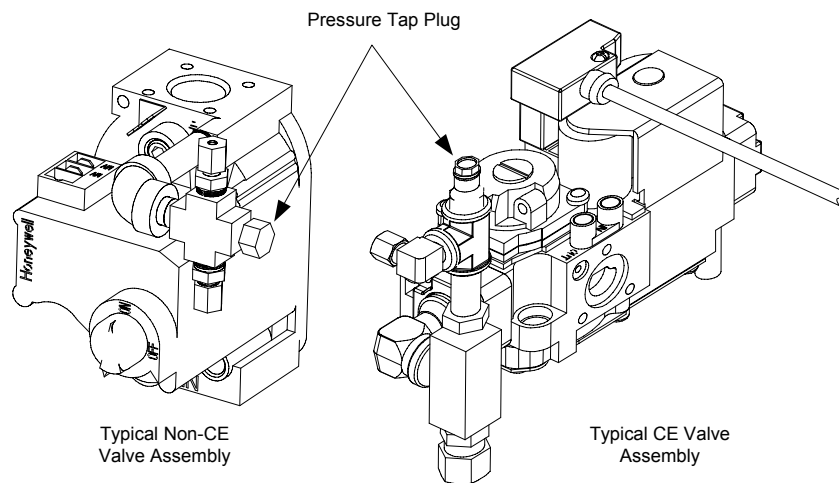

3. Insert the fitting for a gas pressure-measuring device into the pressure tap hole.
4. **On non-CE fryers only**, place the gas valve in the ON position.
5. Place the fryer power switch in the ON position. When the burner has lit and burned steadily for at least one minute, compare the gas pressure reading to the pressure for the corresponding gas in the appropriate table on the following page. The tables list the burner manifold gas pressures for each of the gas types that can be used with this equipment.

CE Standard Burner Manifold Gas Pressures	
Gas	Pressure (mbar)
	Single Vat
Natural Gas Lacq (G20) under 20 mbar	7
Natural Gas Gronique * (G25) under 25 mbar	10
Natural Gas Gronique (G25) under 20 mbar	10
Butane/Propane (G30) at 28/30 or 50 mbar	17
Propane (G31) under 37 or 50 mbar	20

* Belgian G25 = 7,0 mbar

Non-CE Standard Burner Manifold Gas Pressures	
Gas	Pressure
Natural	3" W.C. 0.73 kPa
Propane	8.25" W.C. 2.5 kPa

6. To adjust the burner gas pressure, remove the cap from the gas valve regulator and adjust to the correct pressure.

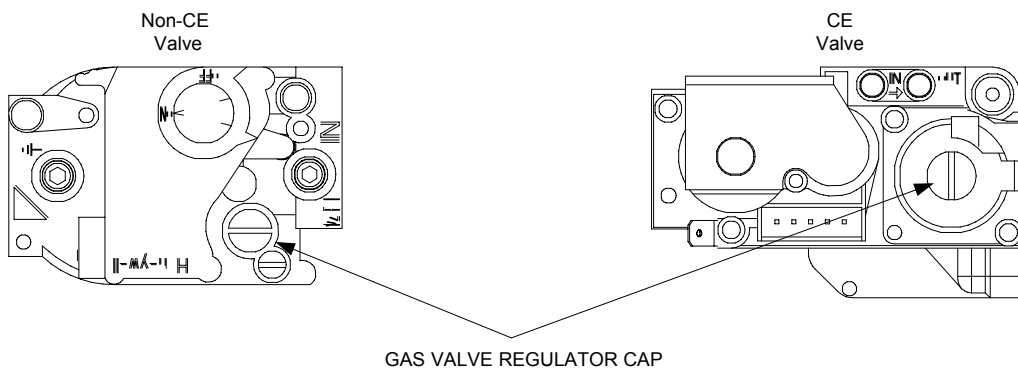

7. Place the fryer power switch (and the gas valve in non-CE fryers) in the OFF position. Remove the fitting from the pressure tap hole and reinstall the pressure tap plug.

1.8 Measuring Flame Current

When the burner flame is properly adjusted, it will produce a current between 2.5 μA and 3.5 μA . Flame current is measured by placing a *microamp* (not milliamp) meter in series with the sensing wire on the ignitor. This is accomplished as follows:

1. Place the fryer power switch in the OFF position.
2. Disconnect the sensing wire from one of the burner ignitors and connect it to the positive lead of the meter. Connect the negative lead of the meter to the terminal from which the sensing wire was removed.

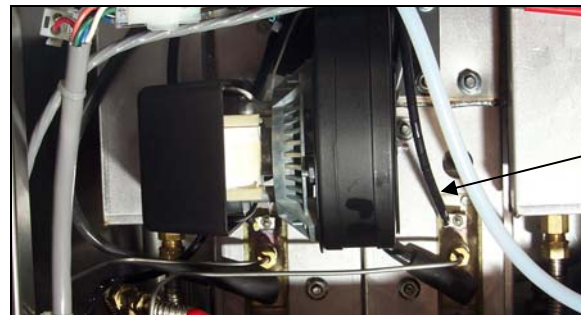

Flame Sensor Wire
(Right Burner)

3. Place the fryer power switch in the ON position to light the burners. After the frypot temperature reaches 200°F (93°C), wait at least one minute before checking the reading. **NOTE:** The closer the unit is to normal operating temperature, the more accurate the reading will be.

1.9 Replacing Fryer Components

1.9.1 Replacing the Computer or the Computer Wiring Harnesses

1. Disconnect the fryer from the electrical power supply.
2. The computer bezel is held in place by tabs at the top and bottom. Slide the metal bezel up to disengage the lower tabs. Then slide the bezel down to disengage the upper tabs.
3. Remove the two screws from the upper corners of the computer. The computer is hinged at the bottom and will swing open from the top.
4. Unplug the wiring harnesses from the connectors on the back of the computer (see following page) marking their position for reassembly and disconnect the grounding wires from the terminals. Remove the computer by lifting it from the hinged slots in the control panel frame.



5. Install the replacement computer. Reinstall the control panel assembly by reversing steps 1 thru 4.
6. Readdress the new CM7 computer. The readdress procedure can be performed from any one CM7 computer in the bank.

1.9.2 Replacing the Temperature Probe or High-Limit Thermostat

1. Disconnect the fryer from the electrical supply.
2. Drain cooking oil below the level of the probe or thermostat.
3. Lift up on the bezel to disengage the tabs on its lower edge from the control panel frame.
4. Remove the top two screws in the upper corners of the computer.
5. Swing the computer out from the top and allow it to rest on its hinge tabs.
6. Disconnect the computer wiring harness and ground wire from the back of the computer and remove the computer by lifting it from the hinge slots in the control panel frame.
7. Disconnect the ignition cables from the ignitors by grasping the boots and gently pulling toward you.
8. Disconnect the flame sensor wires from the flame sensors.
9. Disconnect the sound device lead from the interface board.
10. If working on the left frypot, cut the wire tie on the wiring bundle and disconnect the main wiring harness 15-pin connector.
11. Remove the component box mounting screws.
12. Rotate the top of the component box out of the frame and carefully pull it out enough to disconnect the wiring harness plug from the back of the box. This will leave one set of wires, enclosed in spiral wrap, connected to the component box.
13. Remove the box and set it atop the fryer to expose the temperature probe and high-limit thermostat.
14. Unscrew the probe or thermostat from the frypot.
15. Apply Loctite[®] PST56765 pipe thread sealant or equivalent to the replacement part threads and screw the replacement part into the frypot, torquing to 180 inch-pounds.
16. Connect the wires from the new component as follows:
 - a. If replacing the temperature probe, use a pin pusher to disconnect (one at a time) the red and white leads from the connector and insert the corresponding leads from the new probe into the plug..
 - b. If replacing the high-limit thermostat, use a pin pusher to disconnect the lead running to the connector and insert the corresponding lead from the new thermostat. Disconnect the other lead from the drain safety switch and connect the remaining lead from the new thermostat.
17. Reverse steps 1 through 13 to complete the procedure.

1.9.3 Replacing the Interface Board

1. Perform steps 1 through 4 from section 1.9.1.
2. Disconnect the wires attached to the interface board, marking or making a note of the wires and terminals to facilitate reconnection.
3. Remove the nuts at each corner of the interface board and carefully pull it from the studs far enough to allow the connector on the back of the board to be disconnected, then remove the board from the box. When removing the board, be careful not to lose the spacers that fit over the studs behind the board.
4. Recover the relay(s) from the failed interface board and install on the replacement board.
5. Reverse the procedure to install the replacement board, being sure that the spacers behind the board are in place.
6. Reverse the steps to reinstall the computer.

1.9.4 Replacing an Ignition Module

1. Disconnect the fryer from the electrical supply.
2. Lift up on the bezel to disengage the tabs on its lower edge from the control panel frame.
3. Remove the top two screws in the upper corners of the computer.
4. Swing the computer out from the top and allow it to rest on its hinge tabs.
5. Disconnect the wires from the ignition module, marking or making a note of the wires and terminals to facilitate reconnection.
6. Remove the four ignition module screws and pull the module from the component box.
7. Move the spacers to the new module.
8. Reverse the procedure to install the replacement module.

1.9.5 Replacing an Ignitor Assembly



DANGER

Drain the frypot or remove the handle from the drain valve before proceeding further.

1. Disconnect the fryer from the electrical supply.
2. Disconnect the flame sensor wire by carefully pulling its push-on terminal from the terminal strip on the ignitor. Disconnect the gas enrichment tube at the ignitor-end compression fitting. Disconnect the ignition cable from the ignitor by grasping its boot and gently pulling toward you. (See photo below)

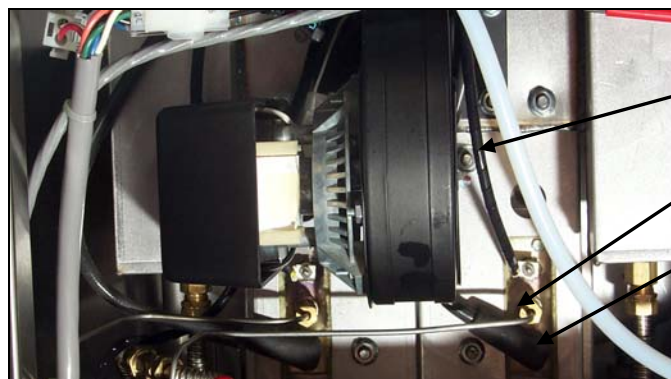

3. Remove the sheet metal screws securing the ignitor to the mounting plate and pull the ignitor from the fryer.
4. Reverse the procedure to install the replacement ignitor.

1.9.6 Replacing or Cleaning a Combustion Air Blower

1. Disconnect the blower wiring harness, remove the blower assembly mounting nuts, and remove the blower assembly from the fryer. If cleaning the motor, continue with Step 2; otherwise, install the replacement blower, reconnect the wiring harness, and then go to Step 6.

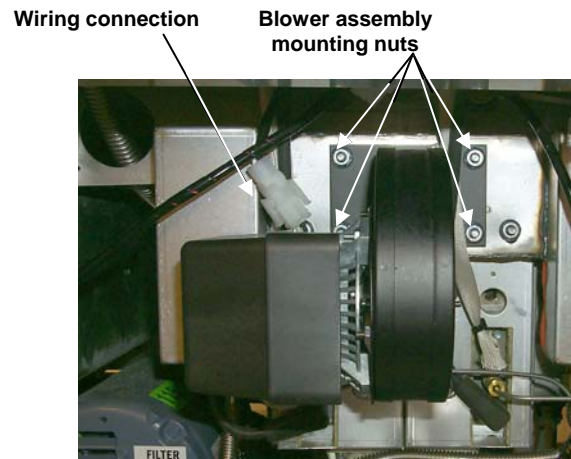

2. Remove the blower motor shield and separate the blower motor from the housing as shown in the illustration below.

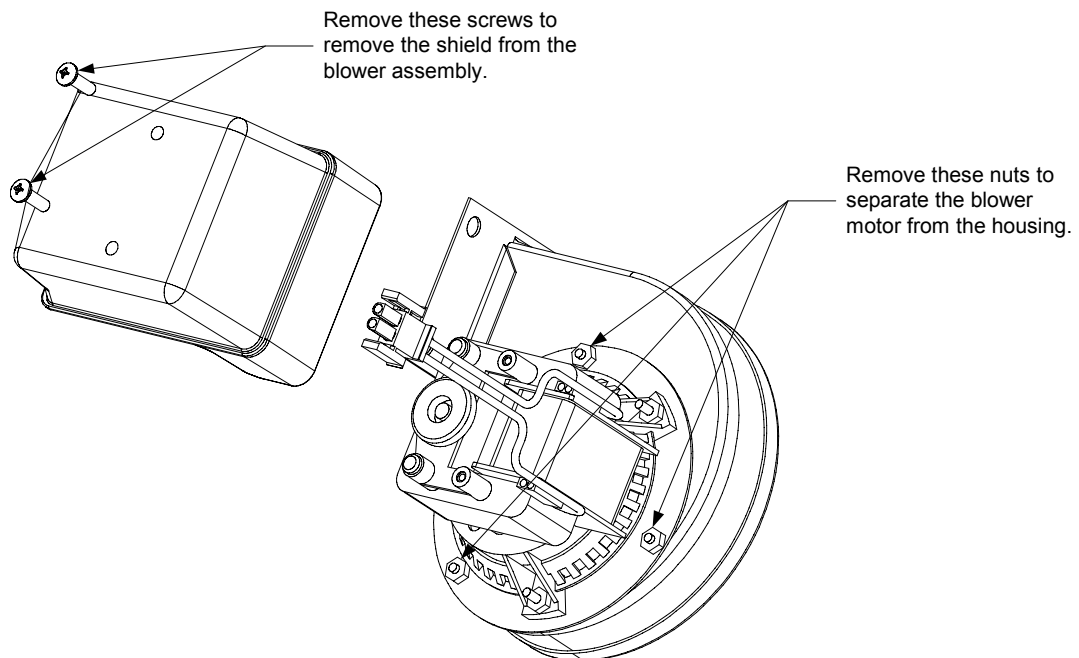

3. Wrap the motor with plastic wrap to prevent water from entering it. Spray degreaser or detergent on the blower wheel and the blower housing. Allow it to soak for five minutes. Rinse the wheel and housing with hot tap water, then dry with a clean cloth.

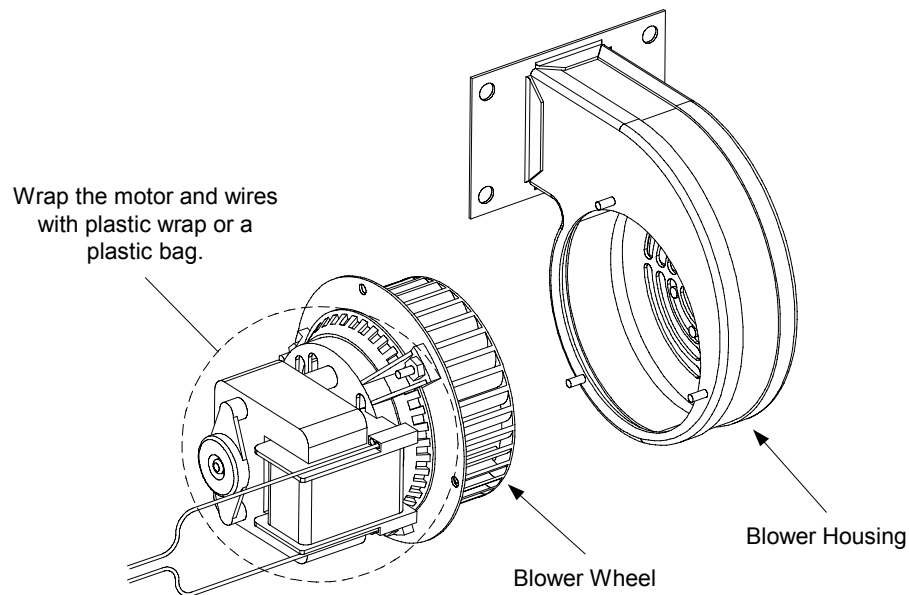

4. Remove the plastic wrap from the blower motor assembly. Reassemble the blower motor assembly and blower housing. Reinstall the blower shield.
5. Reinstall the blower assembly in the fryer and reconnect the wiring disconnected in Step 1.
6. Light the fryer in accordance with the procedure described in Chapter 3, Section 3.2.2 of the Protector® Series Gas Fryer Installation and Operation Manual (P/N 819-6339).
7. After the burners have been lit for at least 90 seconds, observe the flames through the burner viewing ports located on each side of the combustion air blower.

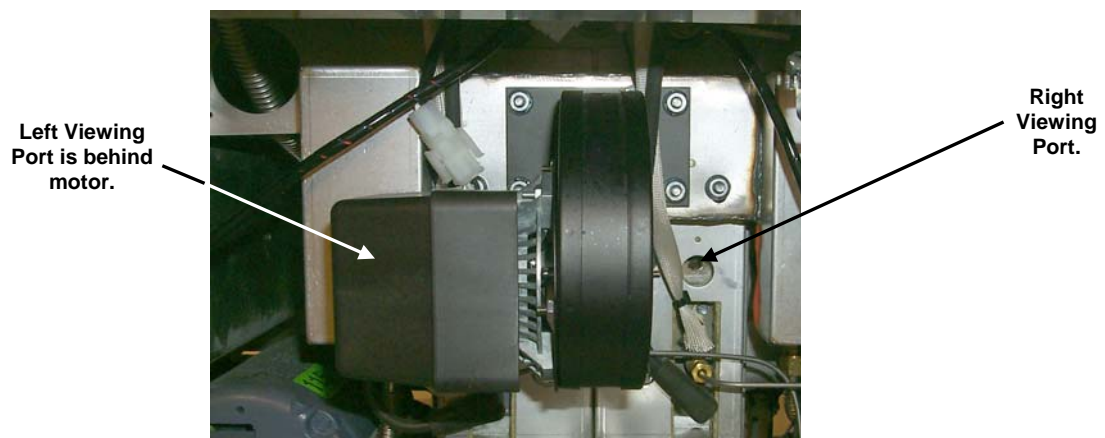

The air/gas mixture is properly adjusted when the burner manifold pressure is in accordance with the applicable table on page 1-6 and the burners display a bright orange-red glow. If a blue flame is observed or if there are dark spots on a burner face, the air/gas mixture requires adjustment.

1.9.7 Adjusting the Air/Gas Mixture

On the side of the blower housing opposite the motor is a shutter plate with a locking nut. Loosen the nut enough to allow the shutter to be moved, then adjust the position of the shutter to open or close the air intake opening until a bright orange-red glow is obtained. Carefully hold the shutter in position and tighten the locking nut (see illustration on the following page).

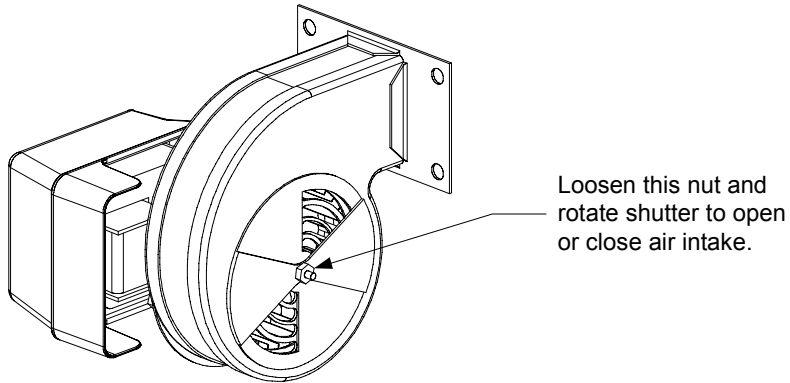

1.9.8 Replacing a Gas Valve

1. Disconnect fryer from electrical and gas supplies.
2. Disconnect the drain safety and high-limit thermostat wires from the gas valve. Mark each wire to facilitate reconnection.
3. Remove the vent tube (on non-CE fryers) and the enrichment tube fitting from the valve. Disconnect the flexible gas line(s).

If replacing the left-most valve on any configuration, or the right valve on a two-fryer battery, follow the instructions below. If replacing valves in other positions, skip to “ALL OTHER VALVES.”

- A. Remove the filter pan from the unit. Remove the door adjacent to the valve being replaced.
- B. Uncouple the pipe union and remove the gas valve and associated piping from the unit.
- C. Remove the fittings and associated piping from the failed valve and install them on the replacement valve using Loctite[®] PST56765 or equivalent pipe thread sealant.
- D. Reconnect the gas valve assembly to the fryer using Loctite[®] PST56765 or equivalent pipe thread sealant, and reattach the flexible gas line(s), enrichment tube(s), and the vent tube (on non-CE units). Reconnect the high-limit thermostat wires and drain safety wires to the valve.
- E. Reconnect the fryer to the gas supply and open the cut off valve. Apply a solution of soapy water around each connection to check for gas leaks. Eliminate any that are found.
- F. Position the pan rail assembly beneath the fryer and rest the rear end of the rail on the cabinet frame. Install the two nuts and bolts behind the front face of the rail, but do not tighten them. Install the nut and bolt at the rear end of the filter rail and tighten securely.
- G. Reattach the screws for the pan rails. Install the filter pan in the unit to make sure that all components are properly aligned.
- H. Reconnect the fryer to the electrical power supply and check for proper operation. When proper operation has been verified, reinstall the door removed in Step A.

ALL OTHER VALVES

4. Carefully unscrew the valve from the manifold. **NOTE:** Some models may have the valve attached to the manifold by means of a pipe union. In such cases, remove the valve by uncoupling the union.

5. Remove all fittings from the old gas valve and install them on the replacement valve, using Loctite® PST56765 or equivalent pipe thread sealant.
6. Reconnect the gas valve assembly to the fryer using Loctite® PST56765 or equivalent pipe thread sealant, and reattach the flexible gas line(s), enrichment tube(s), and the vent tube (on non-CE units). Reconnect the high-limit thermostat wires and drain safety wires to the valve.
7. Reconnect the fryer to the gas supply and open the cut off valve. Apply a solution of soapy water around each connection to check for gas leaks. Eliminate any that are found.
8. Reconnect the fryer to the electrical power supply and check for proper operation.

1.9.9 Replacing a Burner Assembly

1. Disconnect the unit from the electrical and gas supplies.
2. Remove the combustion air blower per the procedure found in Section 1.6.6.
3. Remove the four nuts from the air plenum assembly and pull the assembly straight out toward you until it clears the burner tubes.
NOTE: On a dual-vat fryer, it may be necessary to remove the drain valve handles before the plenum can be removed.
NOTE: If the flexible oil return lines are blocking the plenum, carefully bend them upward enough to clear the plenum.
4. Disconnect the ignition cable from the ignitor by grasping its boot and pulling gently toward you. Disconnect the flame sensor wire from the ignitor by gently pulling its push-on terminal from the terminal strip on the ignitor.
5. Disconnect the flexible gas lines from the burner orifice and the enrichment tube from the ignitor assembly.
6. Remove the four ¼-inch nuts securing the outer front covers to the frypot assembly.
7. Remove the sheet metal screws at the top of the outer front covers and pull the covers straight out toward you until clear of the mounting studs.
8. Remove the washers and tubular spacers from the mounting studs, then pull the inner covers straight out toward you until clear of the mounting studs.
9. Grasp the burner firmly and pull it toward you until it clears the burner channels, taking care not to damage the ceramic tiles in the process.
10. Clean all debris from the burner channels and combustion area.
11. Inspect the upper and lower burner rails for cracked or burned out welds.
 - a. If the welds in the lower rail are cracked or burned out, the frypot must be replaced. Refer to Section 1.6.11 for procedure.
 - b. If the welds in the upper rail are cracked or burned out, the upper rail must be replaced. Refer to Section 1.6.12 for procedure.
12. Place a new insulating strip along the top, rear, and bottom edge of the burner and carefully slide it straight into the rails. **NOTE:** Use P/N 826-0931 for full-vat frypots and P/N 826-0932 for dual-vat frypots.
13. Reverse steps 1 through 9 to reassemble the components.
14. Fill the frypot with oil. Turn the fryer on, turn off or bypass the melt cycle, and operate the unit for at least 10 minutes.
15. Visually examine the burner flame. The color and intensity on both sides should be the same.
16. Use an inspection mirror to check for leaks in areas that cannot be directly observed.
17. If a leak is detected, tighten all the lower insulation retainer nuts, allow the frypot to run for five additional minutes, and repeat steps 15 and 16.

18. If the leak persists, use a rubber hammer and a small block of wood to tap the corners of the lower combustion chamber insulation retainers. Repeat steps 15 through 17. **Repeat this step until no leakage is detected.**

1.9.10 Replacing the Filter Motor, Filter Pump, or Filter Pump Solenoid Valve

1. Disconnect the unit from the electrical power supply.
2. Remove the filter pan from the unit.
3. Position a container beneath the oil return fitting at the front of the cabinet. Disconnect the flexible oil line from the fitting, allowing any residual oil to drain into the container.
4. At the rear of the fryer, unplug the left connector (as viewed from the rear of the fryer) from the transformer box.
5. Remove the four nuts and bolts attaching the motor mount to the rear motor mount support.
6. At the front of the fryer, remove the cover plate from the front of the motor and disconnect the motor wires.
7. Place a 1-foot (30.5-cm) length of wood (or similar support) beneath the motor mount near the front of the unit and remove the two remaining nuts and bolts attaching the motor mount to the front cabinet cross-brace.
8. Carefully remove the support and lower the motor mount to the floor, allowing the rear of the mount to slide forward and off the rear motor mount support.
9. Disconnect the return flexline from the pump. The motor and pump assembly can now be pulled from beneath the fryer and the failed component can be removed and replaced.
10. Position the replacement motor and pump assembly beneath the fryer and reconnect the oil return flexline to the pump. Lift the rear of the motor mount up and onto the rear motor mount support.
11. Lift the front of the motor mount up and support it with a 1-foot (30.5-cm) piece of wood or a similar support. Install but do not tighten the two nuts and bolts that attach the motor mount to the front cabinet cross-brace.
12. Install and tighten the four nuts and bolts that secure the motor mount to the rear motor mount support.
13. At the front of the fryer, tighten the two nuts and bolts at the front of the motor mount. Reconnect the motor power wires and reinstall the wiring cover plate.
14. Reconnect the oil return flexline and reinstall the filter pan.
15. Reconnect the unit to the electrical power supply, fill the frypots with oil and check for proper operation.

1.9.11 Replacing the Frypot

1. Disconnect the fryer from the electrical and gas supplies.
2. Remove the filter pan from the unit and drain one frypot at a time into a Shortening Disposal Unit (SDU) or other appropriate metal container.



DO NOT attempt to drain more than one full frypot into the SDU at one time.

3. Dismount the topcap by removing the screws on the bottom of each front corner and lifting the topcap straight up.
4. Remove the bezels by lifting them up to disengage the tabs along the lower edges from the slots in the control panel frame. Remove the top screws in the upper corners of the computer.

5. Grasp the upper edge of each computer and swing the computer downward. Unplug the computer wiring harness and grounding wire from the back of each computer.
6. Remove the computers by lifting them from the hinge slots in the control panel frame.
7. Disconnect the sound device wire from the interface board.
8. Disconnect the flame sensor wires by carefully pulling the push-on terminals from the terminal strips on the ignitors. Disconnect the gas enrichment tube at the ignitor-end compression fitting. Disconnect the ignition cables from the ignitors by grasping the boots and gently pulling toward you.
9. Remove the two mounting screws on each side of the component box and rotate the top of the box out of the frame. Carefully pull it out enough to disconnect the wiring harness connector from the back of the box. Cut any ties that prevent the box from being pulled out of the control panel frame.
10. Carefully pull the box clear of the frame and rest it on top of the fryer.
11. Using a pin pusher, remove the temperature probe, high-limit thermostat wires and RTD probe wires from the plugs or terminals, marking each wire to facilitate re-assembly.
12. Remove the cover from the safety drain switch. Disconnect the wires from the switch.
13. Remove the section(s) of drain from the drain valve(s) of the frypot to be removed.
14. Disconnect the gas lines from the burner orifices and ignitor assemblies.
15. Remove the frypot hold down bracket.
16. Remove the screws in the back panel and inside the flue cap at each end that secure the flue cap to the fryer and lift it clear of the fryer.
17. Disconnect the oil return line(s) from the frypot to be removed.
18. Carefully lift the frypot from the fryer cabinet.
19. Remove the drain valve(s), temperature probe(s), high-limit thermostat(s), RTD probes and ignitor assemblies. Inspect each of these components carefully and install them in the replacement frypot if they are in serviceable condition. Use Loctite[®] PST56765 sealant or equivalent on component threads.
NOTE: Some servicers, based upon their experience, recommend that probes and thermostats be replaced whenever a frypot is replaced; however, this remains the customer's decision.
20. Reverse steps 1-19 to reassemble fryer.
NOTE: Care should be taken not to over-torque nuts on frypots made of 400-series stainless steel, as this could tear the material. One turn past hand-tight is sufficient torque.
21. Perform steps 14 through 18 of Section 1.9.9 to ensure that there are no leaks in the burner insulation.

 **CAUTION**

Before installing temperature probe, high-limit thermostat, RTD probe and drain valve on replacement frypot, clean the threads and apply Loctite[®] PST56765 thread sealant or equivalent.

1.9.12 Replacing Frypot Insulation and/or Upper Burner Rails

NOTE: Replacing the burner rails requires completely tearing down the frypot and installing new frypot insulation. Refer to the frypot exploded view below for component identification.

1. Remove the frypot per Section 1.9.11.
2. Remove the burner assemblies (1).
3. Remove insulation retainers and blanket insulation (2).
4. Remove the upper oil zone insulation bracket and upper oil zone insulation (3).
5. Remove the plenum (4).
6. Remove the front lower combustion chamber insulation retainer and insulation (5), and the front lower combustion chamber inner insulation retainer and insulation (6). **NOTE:** Full-vat units have two-piece insulation retainer and insulation components. Dual-vat units have one-piece components.
7. Remove the upper combustion chamber insulation retainer and insulation (7).
8. Remove the inner upper combustion chamber insulation retainer and insulation (8).
9. Remove the rear lower combustion chamber retainers, back, and insulation (9). **NOTE:** Full-vat units have two-piece backs and four retainers. Dual-vat units have one-piece backs and two retainers.
10. Remove the flue assembly (10).

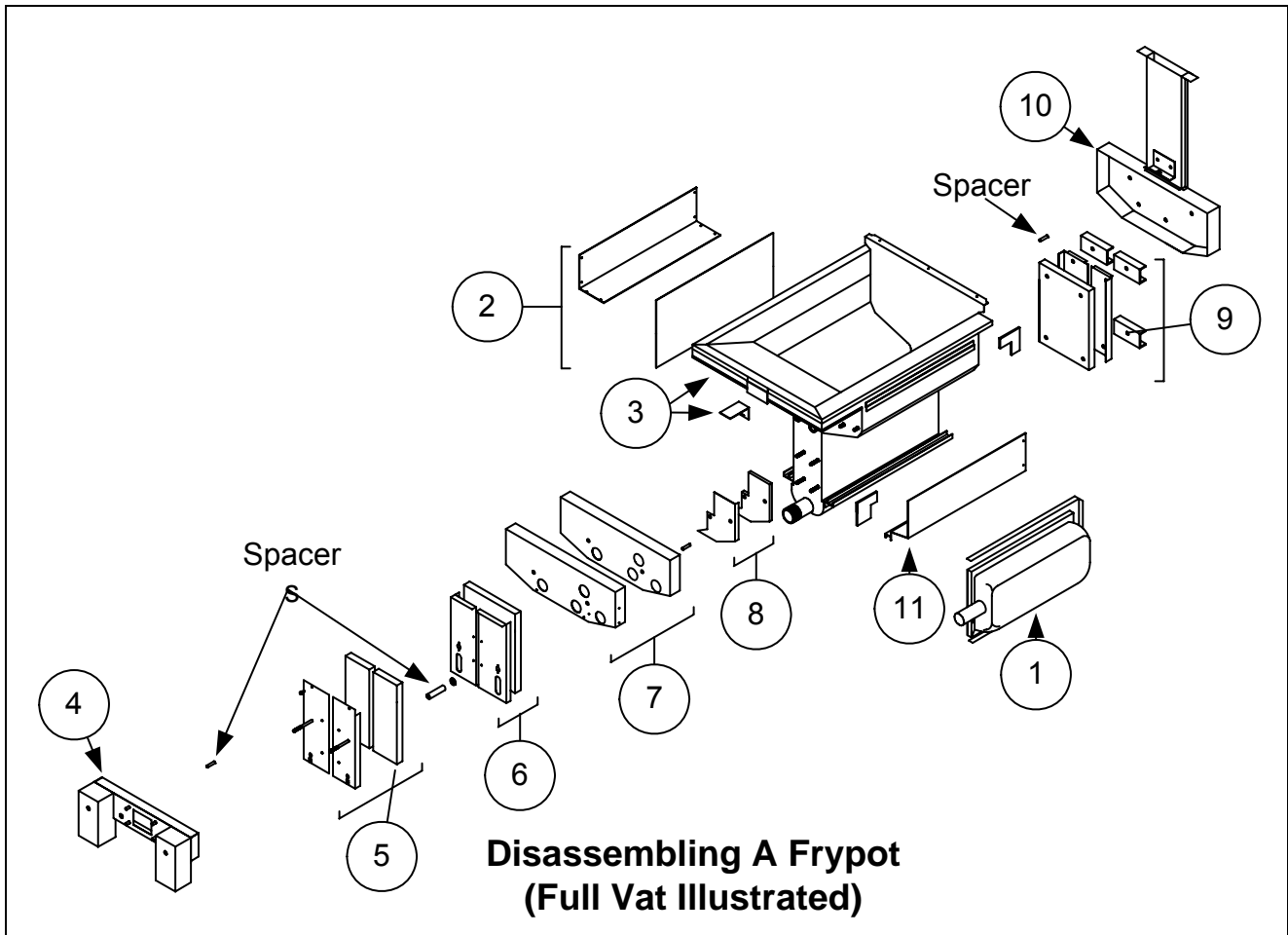

See page 1-18 for reassembly illustration.

11. Remove the upper burner rails (11). **NOTE:** For the following steps, refer to the frypot exploded view on page 1-16 for component identification.
12. Remove any residual insulation, sealant, and/or oil from the exterior of the frypot.
13. Place the “L” shaped pieces of the combustion chamber insulation (1) in the front and rear corners of both upper rail-retaining slots. (See page 1-16).
14. Using a mallet and short piece of wood, tap the corner tabs of the combustion chamber over the insulation to ensure a solid seal of the burner.
15. Install the upper burner rails (2) with the heat deflectors slanting toward the rear of the frypot. The rails will cover the “L” shaped pieces of combustion chamber insulation previously installed.
16. Place the upper inner combustion chamber insulation and insulation retainers (3) on the top two studs on each side of the front of the frypot and secure with ¼”-20 washer-nuts. *It is normal for the retainers to slice off the overhanging insulation.*
17. Place the lower rear combustion chamber insulation (4) on the lower four studs at the rear of the frypot.
18. Place one 1.625-inch tubular spacer (5) on each of the flue assembly (upper) studs at the rear of the frypot. **NOTE:** There are three different sizes of spacers. Verify the size to ensure the correct spacers are installed.
19. Press the flue assembly (6) over the burner rails. It may be necessary to use a rubber mallet or screwdriver to align the components. Use four ¼”-20 washer nuts to secure the flue assembly. **Do not tighten the retainer nuts at this point. They should be finger-tight only.** **NOTE:** The flue edge will cover one to two inches of the lower insulation.
20. Install the lower rear combustion chamber back(s) and retainer(s) (7) with the flanged edge(s) against the flue. Secure with ¼”-20 washer nuts. **NOTE:** Full-vat units have two-piece backs and four retainers. Dual-vat units come with one-piece backs and only two retainers.
21. Insert the burners (9) into the rails to ensure the rail spacing and alignments are correct. The burner should slide freely into and out of the rails. The upper rail can be bent slightly to increase or decrease tension on the burner and the edges of the slot can be closed or opened slightly to best fit the burner frame.
22. Carefully wrap a strip of burner insulation (8) tightly around the rear and sides of the burner frame (9), with the glass-tape side of the strip on the outside. **Do not use duct tape or adhesive to secure the strip to the burner frame.**
23. Align the burner to the burner rails while maintaining tension on the insulation strip. Insert the burner at a slight angle and begin pushing the burner slowly into the rails until it contacts the rear combustion chamber. The fit should be snug, but not excessively tight.
24. Verify that the burners are flush with the front edge of the burner rails. Remove the excess burner insulation by cutting with a knife or diagonal pliers. **Do not try to tear the insulation!**
25. Insert the upper front insulation (10) into its retainer (11), making sure that the holes in each piece are aligned with one another. Install the assembly with the insulation side toward the frypot and secure with ¼”-20 washer-nuts. **Do not over tighten.**
26. Place a washer on each of the four lower studs on the front of the frypot. Install the lower inner front insulation (12) with the rectangular openings toward the drain valve nipple. Install the lower inner front insulation retainer(s) (13). **NOTE:** Full-vat units have a two-piece insulation retainer. Dual-vat units have a one-piece retainer.
27. If necessary, replace the sight-glasses and insulation (14).
28. Place one washer and one 1.888-inch spacer (15) on each stud. **NOTE:** There are three different sizes of spacers. Verify the size to ensure the correct spacers are installed.
29. Insert the front lower insulation (16) into the front lower insulation retainer(s) (17) and install assembly on frypot. Secure with ¼”-20 washer-nuts. If frypot uses two retainers, connect them

together with two ¼” self-tapping screws. NOTE: Full-vat units have a two-piece insulation retainer and two pieces of insulation. Dual-vat units have one-piece components.

30. Return to the rear of the frypot and fully tighten all washer-nuts.
31. Remove and replace the plenum gaskets (18).
32. Place a 0.938-inch spacer (19) on the plenum-mounting studs, and mount the plenum (20). Ensure the gaskets are clear of the burner tubes by pulling the plenum back slightly. Place a washer on each stud and secure plenum with ¼”-20 lock-nuts.
33. Install the upper oil-zone insulation (21) by pressing it under the upper combustion chamber metalwork. Secure the insulation with the bracket (22) and ¼” self-tapping screws.
34. Install the upper burner rail blanket insulation (23). Position any excess insulation toward the top of the frypot. Avoid overhang past the bottom of the upper burner rail. Overhang in this area will make future burner replacement more difficult.
35. Cover the insulation with the insulation retainer (24), and secure with ¼” self-tapping screws.
36. Reinstall probes, drain valves, high-limit thermostats, and other pipe fittings using Loctite® PST56765 sealant or equivalent on the threads.

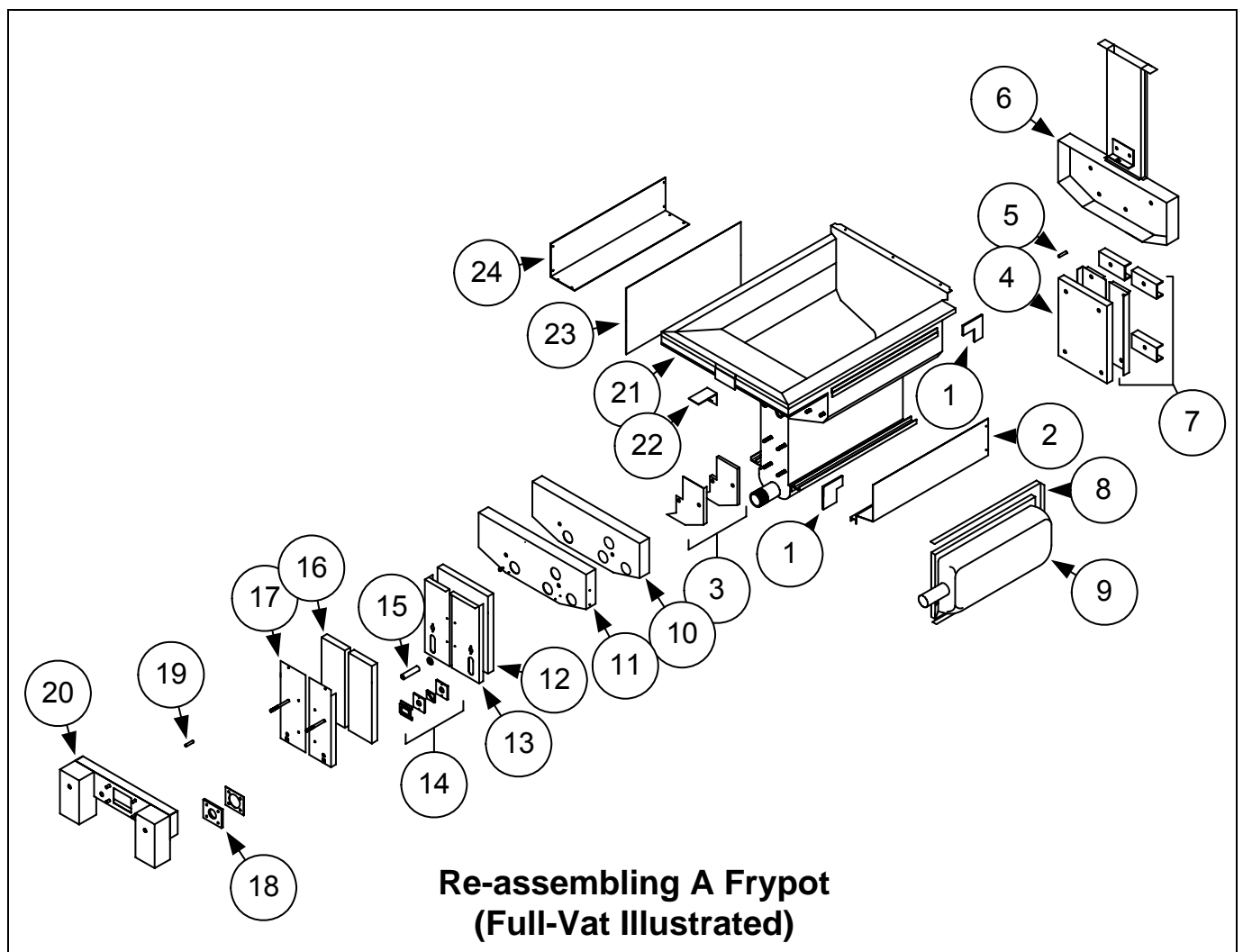

1.10 Troubleshooting and Problem Isolation

Because it is not feasible to attempt to include in this manual every conceivable problem or trouble condition that might be encountered, this section is intended to provide technicians with a general knowledge of the broad problem categories associated with this equipment, and the probable causes of each. With this knowledge, the technician should be able to isolate and correct any problem encountered.

Problems you are likely to encounter can be grouped into six categories:

1. Ignition failure
2. Improper burner function
3. Improper temperature control
4. Computer malfunctions
5. Filtration malfunctions
6. Leakage

The probable causes of each category are discussed in the following sections. A series of Troubleshooting Guides is also included at the end of the chapter to assist in solving some of the more common problems.

1.10.1 Ignition Failure

Ignition failure occurs when the ignition module fails to sense a flame within the 4-second time delay period and locks out. When this happens, the module sends 24 VAC through the interface board alarm circuit to the computer.

CM7 computers display “**IGNITION FAILURE.**”

The three primary reasons for ignition failure, listed in order of probability, are problems related to:

1. Gas and/or electrical power supplies
2. Electronic circuits
3. Gas valve.

PROBLEMS RELATED TO THE GAS AND/OR ELECTRICAL POWER SUPPLIES

The main indicators of this are that an entire battery of fryers fails to light and/or there are no indicator lights illuminated on the fryer experiencing ignition failure. Verify that the quick disconnect fitting is properly connected, the fryer is plugged in with connector twisted and locked, the main gas supply valve is open, and the circuit breaker for the fryer electrical supply is not tripped.

PROBLEMS RELATED TO THE ELECTRONIC CIRCUITS

If gas and electrical power are being supplied to the fryer, the next most likely cause of ignition failure is a problem in the 24 VAC circuit. Verify that the drain valve is fully closed. The valve is attached to a microswitch that must be closed for power to reach the gas valve (often, although the valve handle appears to be in the closed position, the microswitch is still open). If the valve is fully closed, refer to Section 1.11.1, **TROUBLESHOOTING THE 24 VAC CIRCUIT.**

Some typical causes of ignition failure in this category include a defective sensing wire in the ignitor assembly, a defective module, a defective ignition wire, and a defective ignitor.

Occasionally, an ignition failure situation occurs in which all components appear to be serviceable and the microamp reading is within specification, but the unit nevertheless goes into ignition failure during operation. The probable cause in this case is an intermittent failure of an ignition module. When the unit is opened up for troubleshooting, the module cools down enough to operate correctly; however, when the unit is again closed up and placed back into service the module heats up and fails.

PROBLEMS RELATED TO THE GAS VALVE

If the problem is not in the 24 VAC circuit, it is most likely in the gas valve, itself. Before replacing the gas valve, refer to Section 1.11.2 **TROUBLESHOOTING THE GAS VALVE**.

1.10.2 Improper Burner Function

With problems in this category, the burner ignites but exhibits abnormal characteristics such as “popping,” dark spots on the burner ceramics, fluctuating flame intensity, and flames shooting out of the flue.

“*Popping*” indicates delayed ignition. In this condition, the main gas valve is opening but the burner is not immediately lighting. When ignition does take place, the excess gas “explodes” into flame, rather than smoothly igniting.

The primary causes of popping are:

- Incorrect or fluctuating gas pressure
- Defective or incorrectly adjusted combustion air blower
- Inadequate make-up air
- Heat-damaged computer or ignition module
- Cracked ignitor or broken ignition wire
- Defective ignition module
- Cracked burner tile (typically causes a very loud pop).

If popping occurs only during peak operating hours, the problem may be incorrect or fluctuating gas pressure. Verify that the incoming gas pressure (pressure to the gas valve) is in accordance with the appropriate CE or Non-CE Standard found in Section 2.3 page 2-4 of the Protector[®] Series Gas Fryer Installation and Operation Manual (PN 819-6339), and that the pressure remains constant throughout all hours of usage. Refer to Section 1.7, **Checking the Burner Manifold Gas Pressure** in this manual for the procedure for checking the pressure of gas supplied to the burner.

If popping is consistent during all hours of operation, the most likely cause is an insufficient air supply. Check for “negative pressure” conditions in the kitchen area. If air is flowing into the kitchen area, this indicates that more air is being exhausted than is being replenished and the burners may be starved for air.

If the fryer’s gas and air supplies are correct, the problem is most likely with one of the electrical components. Examine the ignition module and computer for signs of melting, distortion, and/or discoloration due to excessive heat build-up in the fryer (this condition usually indicates improper flue performance). A melted or distorted ignition module is automatically suspect and should be replaced; however, unless the condition causing excessive heat is corrected, the problem is likely to recur.

Verify that the ignition wire is tightly connected at both ends and free of obvious signs of damage. Again, if damage is due to excessive heat in the fryer, that problem must also be corrected. Check for proper operation by disconnecting the wire from the ignitor (spark plug), inserting the tip of a screw driver into the terminal. With the insulated handle of the screwdriver, hold the shaft near the frame of the fryer as the power switch is placed in the ON position. A strong, blue spark should be generated for at least four seconds.



DANGER

Make sure you are holding the insulated handle of the screwdriver and not the blade. The sparking charge is approximately 25,000 volts.

Examine the ignitor (spark plug) for any signs of cracking. A cracked ignitor must be replaced.

If all other causes have been ruled out, examine the burner tiles for any signs of cracking. If cracking is found, the burner must be replaced.

Fluctuating flame intensity is normally caused by either improper or fluctuating incoming gas pressure, but may also be the result of variations in the kitchen atmosphere. Verify incoming gas pressure in the same way as for “popping,” discussed in the preceding paragraphs. Variations in the kitchen atmosphere are usually caused by air conditioning and/or ventilation units starting and stopping during the day. As they start and stop, the pressure in the kitchen may change from positive or neutral to negative, or vice versa. They may also cause changes in airflow patterns that may affect flame intensity.

Dark spots on the burner tiles are the result of an improper air/gas mixture. Adjust the combustion air blower to reduce the amount of air in the mixture to correct this problem

Flames shooting out of the flue are usually an indication of negative pressure in the kitchen. Air is being sucked out of the burner enclosure and the flames are literally following the air. If negative pressure is not the cause, check for high burner manifold gas pressure in accordance with the procedures in Section 1.7.

An *excessively noisy burner*, especially with *flames visible above the flue opening*, may indicate that the gas pressure is too high, or it may simply be that the gas valve vent tube is blocked. If the incoming gas pressure is correct and the vent tube is unobstructed, the gas valve regulator is probably defective.

Occasionally a burner may apparently be operating correctly, but nevertheless the fryer has a *slow recovery rate* (the length of time required for the fryer to increase the oil temperature from 250°F to 300°F (121°C to 149°C)). The primary causes of this include an over-filled frypot, a dirty or out-of-adjustment combustion air blower, low burner manifold pressure, and/or damaged burner tiles. Adding oil to the frypot during the recovery process will also cause a slow recovery rate.

If these causes are ruled out, the probable cause is a misadjusted gas valve regulator. Refer to Section 1.7, **Checking the Burner Manifold Gas Pressure**, for the gas valve adjustment procedure.

1.10.3 Improper Temperature Control

Temperature control, including the melt cycle, is a function of several interrelated components, each of which must operate correctly. The principle component is the temperature probe. Other components include the interface board, the computer itself, and the ignition module.

Improper temperature control problems can be categorized into melt cycle problems and failure to control at setpoint problems.

MELT CYCLE PROBLEMS

Initiation of the melt cycle with CM7 computers is automatic. Problems may originate from the computer itself, the temperature probe, or a malfunctioning heat relay on the interface board.

FAILURE TO CONTROL AT SETPOINT

Problems in this category may be caused by the temperature probe, the interface board, or the computer.

1.10.4 Computer Malfunctions

RECOVERY TIME

Recovery time – is a method of measuring a fryer’s performance. Put simply, it is the time required for the fryer to increase the oil temperature from 250°F to 300°F (121°C to 149°C). This range is used as a standard since ambient kitchen temperatures can affect the test if lower ranges are used.

The CM7 computer performs the recovery test each time the fryer warms up. An operator can view the results of the test any time the fryer is above the 325°F (163°C) point by pressing the INFO button once when the fryer is on. The test results will be displayed in the computer’s LED panel in minutes and seconds. The maximum acceptable recovery time for Protector® series gas fryers is two minutes and twenty-five seconds.

1.10.5 Filtration Malfunctions

The majority of filtration problems arise from operator error. One of the most common errors is placing the filter pad on the bottom of the filter pan rather than over the filter screen.

Whenever the complaint is “the pump is running, but no oil is being filtered,” check the installation of the filter pad, including that the correct size is being used. While you are checking the filter paper/pad, verify that the O-rings on the filter pan suction tube are present and in good condition. Missing or worn O-rings will allow the pump to suck air and decrease its efficiency.

If the pump motor overheats, its thermal overload will trip and the motor will not start until it is reset. If the pump motor does not start, press the red reset switch located on the front of the motor. If the pump then starts, something caused the motor to overheat. It may be just that several frypots in a large battery of fryers were being filtered one after the other and the pump became hot. Letting the pump cool down for at least a half-hour is all that is required in this case. More often, the pump overheated for one of the following reasons:

- Shortening that remained in the pan after previous filtering solidified in the suction tube recess in the bottom of the pan or the suction tube, itself. Adding hot oil to the pan and waiting a few minutes will usually correct this problem. A flexible wire can be used to clean out the suction tube and the recess in the bottom of the pan. **NEVER** use compressed air to blow solidified shortening out of the suction tube!

- The operator attempted to filter oil that was not heated. Cold oil is thicker and causes the pump motor to work harder and overheat.

If the motor hums but the pump does not rotate, there is a blockage in the pump. Incorrectly sized or installed paper will allow food particles and sediment to pass through the filter pan and into the pump. When sediment enters the pump, the gears can bind up and cause the motor to overload, tripping the thermal overload. Solidified shortening in the pump will also cause it to seize, with similar results.

A pump seized by debris or hard shortening can usually be freed by manually moving the gears with a screwdriver as illustrated on the following page. **Make sure power to the pump motor is off before trying this.**

1. Disconnect power to the filter system.
2. Remove the input plumbing from the pump.
3. Use a screwdriver to manually turn the gears.
 - Turning the pump gears backwards will release a hard particle and allow its removal.
 - Turning the pump gears forward will push softer objects and solid shortening through the pump and allow free movement of the gears.

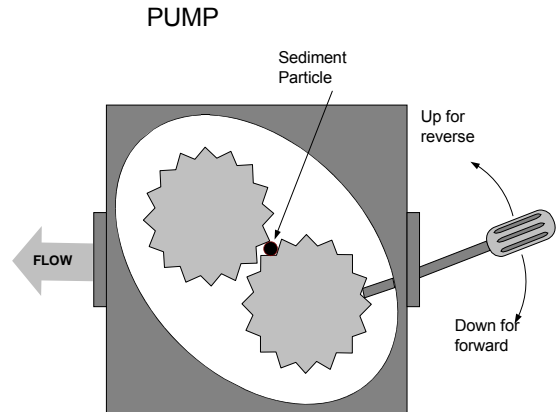

Filter paper/pads that are installed incorrectly will also allow food particles and sediment to pass through and clog the suction tube recess on the bottom of the filter pan or the suction tube, itself. Particles large enough to block the suction tube recess or the suction tube may indicate that the crumb tray is not being used.

The electronics of the FootPrint PRO system, illustrated in the schematic on the following page, are simple and straightforward.

Microswitches, which are attached to handles for each vat and wired in parallel, provide the 24 VAC required activating the pump relay coil when the handles are moved to the ON position. The activated pump relay coil pulls in the pump motor switch, supplying power to the pump motor.

Verifying Solenoid Operation

Proper operation of the 24 VAC manifold and pump solenoids can be verified by removing the pump motor lead from terminal 4 of the pump motor relay in the filter wiring box and then activating the oil return lever. Proper solenoid operation will be evidenced by an audible “click” or vibration of both the pump solenoid and the manifold solenoid.

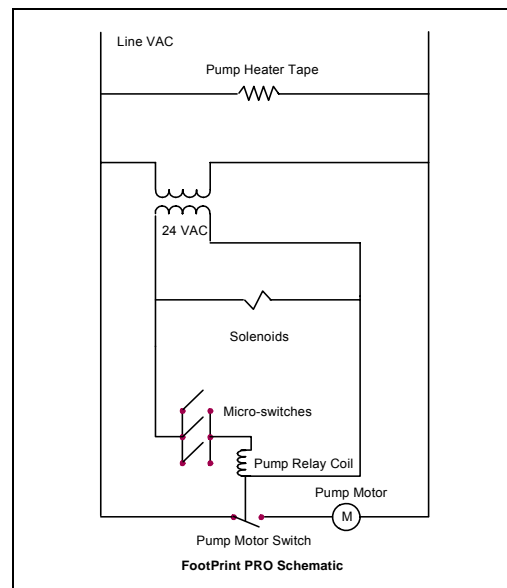

1.10.6 Leakage

Leakage of the frypot will usually be due to improperly sealed high-limit thermostats, RTD's, temperature probes, and drain fittings. When installed or replaced, each of these components must be sealed with Loctite® PST56765 sealant or equivalent to prevent leakage. In very rare cases, a leak may develop along one of the welded edges of the frypot. When this occurs, the frypot must be replaced.

If the sides or ends of the frypot are coated with oil, the most likely cause is spillage over the top of the frypot rather than leakage.

The clamps on the rubber boots that hold the drain tube sections together may loosen over time as the tubes expand and contract with heating and cooling during use. Also, the boot itself may be damaged. If the section of drain tube connected to the drain valve is removed for any reason, ensure that its rubber and clamps are in good condition and properly fitted around the drain tube when it is reinstalled. Also, check to ensure that the drain tube runs downward from the drain along its whole length and has no low points where oil may accumulate.

1.10.7 Basket Lift Malfunctions

Protector® series gas fryers may be optionally equipped with automatic basket lifts to ensure uniform cooking times. Basket lifts will always come in pairs, although each operates independently of the other. A modular basket lift consists of a toothed rod to which the basket lift arm is attached, a reversible-drive gear motor, and a pair of roller-activated microswitches. A gear on the motor shaft engages teeth in the rod. Depending upon the direction of motor rotation, the gear drives the rod up or down.

Timing circuitry in the controller initiates and stops operation of the basket lift depending upon the variables programmed by the operator. When a product button is pressed, the timing circuitry activates a coil to supply power to the motor, which lowers the basket into the frypot.

When the rod contacts and closes the lower microswitch, power to the motor is cut and the direction of current flow is reversed; this reverses the direction of motor rotation. When the programmed cooking time has elapsed, power is again supplied to the motor. The motor raises the basket from the frypot until the rod loses contact with the upper microswitch, cutting power to the motor and again reversing the direction of current flow.

Problems with the basket lift can be grouped into three categories:

- Binds and jams
- Motors and gears
- Electronics.

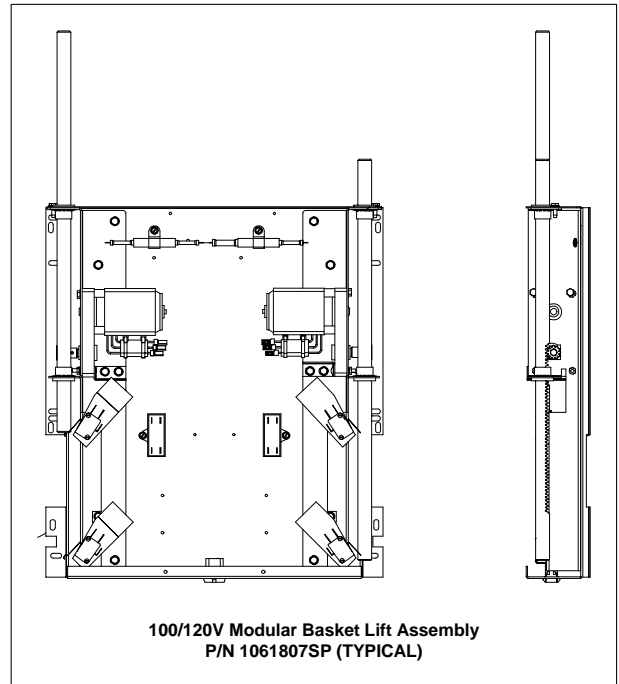

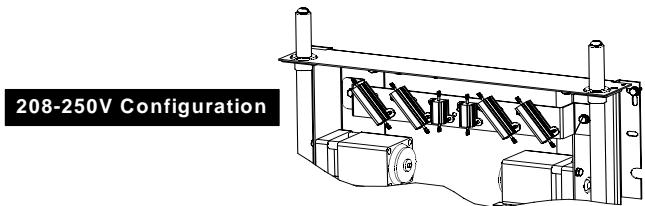
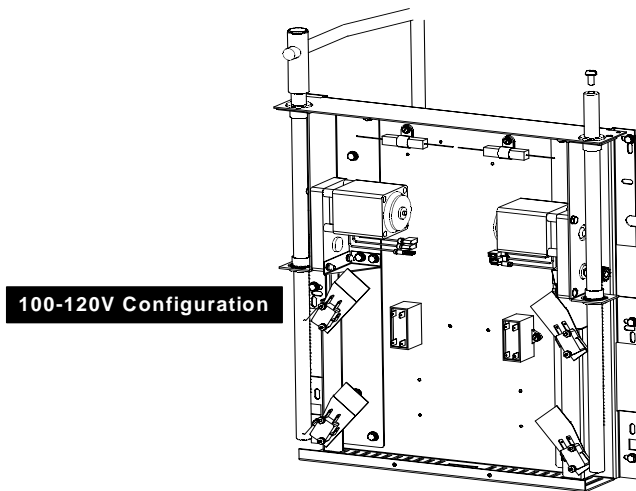

BINDS AND JAMS

Noisy, jerky or erratic movement of the lifts is usually due to lack of lubrication of the rods and bushings. Apply a light coat of Lubriplate[®] or similar lightweight white grease to the rod and bushings to correct the problem.

Another possible cause of binding is improper positioning of the motor, which prevents the gear from correctly engaging the teeth in the rod. To correct the problem, loosen the screws that hold the motor in place and move it forward or backward until the rod has just enough slack to be rotated slightly.

MOTORS AND GEARS

The most likely problem to be encountered in this category is erratic motion of the lift due to a worn drive gear. Failure to keep the lift rod and bushings properly lubricated will cause unnecessary wear of the gear. Correct the problem by replacing the worn gear.

If the lift cycles correctly but fails to remain in the up position (i.e., goes up, but then slowly settles back down into the frypot), the problem is a failed motor brake. This cannot be repaired and the motor must be replaced.

If power is reaching the motor but the motor fails to run, it is burned out and must be replaced.

ELECTRONICS

Within this category are problems associated with the relays, microswitches, capacitors, resistors, interface board, wiring, and controls. The most common problem in this category is a lift that continuously travels up and down. This is usually caused by a microswitch that is out of adjustment.

Troubleshooting the electronics of the basket lift is the process of verifying current flow through the individual components up to and including the motor. Using a multimeter set to the 250 VAC range, check the connections on both sides of the component for the presence of the applied line voltage.

The wiring diagram on the Pages 1-45 and 46 identifies the components and wiring connection points.

1.11 Troubleshooting Guides

The troubleshooting guides on the following pages are intended to assist service technicians in quickly isolating the probable causes of equipment malfunctions by following a logical, systematic process. An additional set of operator troubleshooting guides are contained in Chapter 7 of the BIGLA30 Series Installation and Operation Manual. It is suggested that service technicians thoroughly familiarize themselves with both sets.

1.11.1 Troubleshooting the 24 VAC Circuit

Prior to checking for problems associated with the 24 VAC circuit, ensure that the unit is connected to a power supply, the drain valve is fully closed, and the computer is on and is calling for heat (green dot appears under heat indicator and display toggles between **LOW** and **TEMP**).

NOTE: All voltage measurements must be made within **4 seconds** of the unit calling for heat. If unit does not fire within **4 seconds**, ignition modules will lock out and computer must be turned off, then on to reset.

The following processes will assist you in troubleshooting the 24 VAC circuit and ruling it out as a probable cause:

- **24 VAC is not present on the interface board J3 pin 9 (LED 5 (GV)).**
 1. If LED 3 *is not* continually lit, the probable causes are a failed 24 VAC transformer or failed wiring between the transformer and interface board.
 2. If LED 3 *is* continually lit, check the right PWR terminal (LED 4) for 24 VAC. Verify that the F2 fuse is not blown.
 - a. If 24 VAC *is not* present, the probable cause is a failed interface board, blown fuse or a defective heat relay.
 - b. If 24 VAC *is* present, check for 24 VAC on V1S.
 - i. If 24 VAC *is not* present, check the fuses. If they are good, the probable causes are failed ignition module(s) or a failed interface board. Replace the questionable ignition module with one known to be good to isolate the cause.
 - ii. If 24 VAC *is* present, the probable cause is a failed interface board.
- **24 VAC is present on interface board J3 pin 9 (LED 5 (GV)).**
 1. If 24 VAC *is not* present across the gas valve main coil (MV terminals), probable causes are an open high-limit thermostat or a failed wire between the interface board and gas valve. It may also be caused by a failed drain safety switch.
 - a. Check continuity of high-limit thermostat and drain safety switch. If both are zero, problem is in wiring.
 2. If 24 VAC *is* present across the gas valve main coil (MV terminals), the 24 VAC circuit is working and the problem may be with the gas valve.

24 VOLT CIRCUIT

With Interface Board 106-6706 and
One 807-3366 (FV) Ignition Module

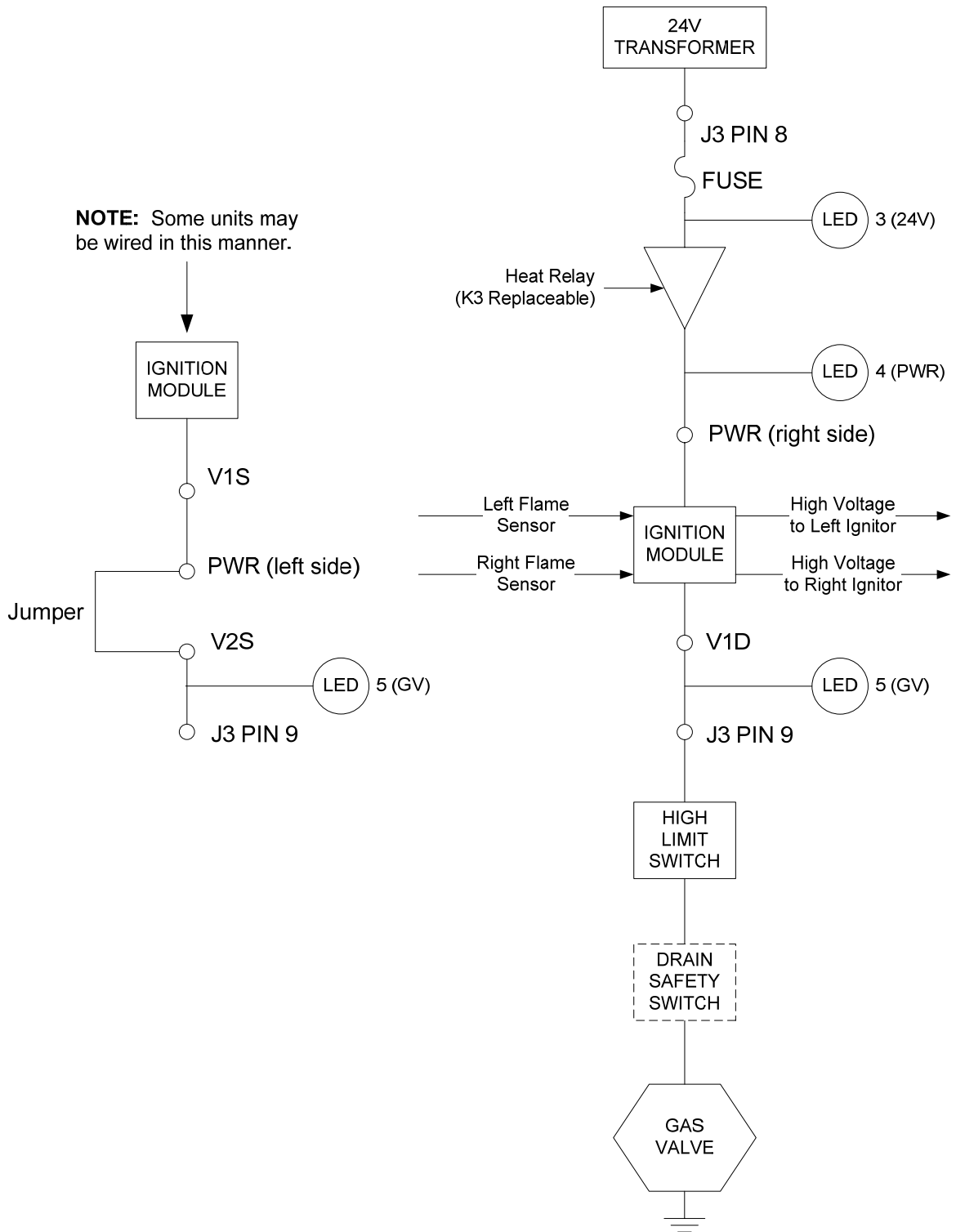

1.11.2 Troubleshooting the Gas Valve

Prior to checking for problems associated with the gas valve, ensure that the unit is calling for heat. Also, for non-CE units, verify that the gas valve is in the ON position.

The following processes will assist you in troubleshooting the gas valve and ruling it out as a probable cause:

- If 24 VAC is not present across gas valve main coil, the probable cause is the 24 VAC circuit. Refer to the 24 VAC circuit troubleshooting guide.
- If 24 VAC is present across gas valve main coil, check the incoming gas pressure and compare to the tables on page 2-4 of the Installation and Operation manual.
 1. If incoming gas pressure *is not* correct, the probable cause is a problem with the gas supply to fryer.
 2. If incoming gas pressure *is* correct, check the burner manifold gas pressure and compare it to the tables on page 2-7 of the Installation and Operation manual.
 - a. If burner manifold gas pressure *is not* correct, the probable cause is an improperly adjusted or failed gas valve. Adjust the valve by following the procedure “Check Burner Manifold Pressure” in Section 1.7 of this manual. If the valve cannot be adjusted, replace it.
 - b. If outgoing gas pressure *is* correct, the gas valve is okay.

1.11.3 Troubleshooting the Temperature Probe



Disconnect the CM7 computer before testing temperature probe resistances to avoid invalid readings

Prior to checking for problems associated with the temperature probe, inspect the probe body for damage while it is still in the frypot. Remove and replace the probe if it is bent, dented, or cracked. Also, inspect leads for fraying, burning, breaks, and/or kinks. If found, replace the probe.

The following processes will assist you in troubleshooting the temperature probe and ruling it out as a probable cause:

Before testing the probe, determine the temperature the cooking oil using another thermometer or pyrometer placed at the tip of the questionable probe.

- **If resistance through J3 pins 2 and 6 is not approximately equal to that given in the Probe Resistance Chart on the following page for the corresponding temperature, the probe has failed and must be replaced.**
- **If resistance through J3 pins 2 and 6 is approximately equal to that given in the Probe Resistance Chart on the following page for the corresponding temperature, measure the resistance through each of the previously tested pins to ground.**
 1. If resistance *is not* 5 mega-Ohms or greater in each pin, the probe has failed and must be replaced.
 2. If resistance *is* 5 mega-Ohms or greater in each pin, the probe is okay.

1.11.4 Replacing the Transformer or Filter Relay

Disconnect the fryer from the electrical power supply. Remove the cover from the transformer box in the rear of the fryer to expose the interior of the transformer box. Replace the transformer or filter

relay marking the wires to ease reassembly. Once replaced, reconnect the power. When replacing a filter relay in the transformer, ensure the 24VAC relay (8070012) is used.

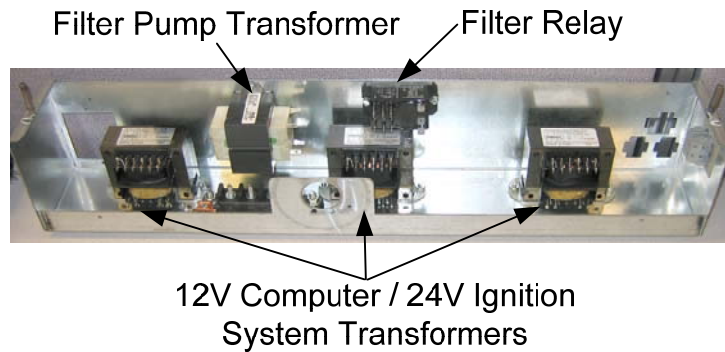

1.12 Probe Resistance Chart

<h2 style="text-align: center;">Probe Resistance Chart</h2> <p style="text-align: center;"><i>For use with Protector[®] Series fryers manufactured with Minco Thermistor probes only.</i></p>																	
F	OHMS	C	F	OHMS	C	F	OHMS	C	F	OHMS	C	F	OHMS	C			
60	1059	16	130	1204	54	200	1350	93	270	1493	132	340	1634	171			
65	1070	18	135	1216	57	205	1361	96	275	1503	135	345	1644	174			
70	1080	21	140	1226	60	210	1371	99	280	1514	138	350	1654	177			
75	1091	24	145	1237	63	215	1381	102	285	1524	141	355	1664	179			
80	1101	27	150	1247	66	220	1391	104	290	1534	143	360	1674	182			
85	1112	29	155	1258	68	225	1402	107	295	1544	146	365	1684	185			
90	1122	32	160	1268	71	230	1412	110	300	1554	149	370	1694	188			
95	1133	35	165	1278	74	235	1422	113	305	1564	152	375	1704	191			
100	1143	38	170	1289	77	240	1432	116	310	1574	154	380	1714	193			
105	1154	41	175	1299	79	245	1442	118	315	1584	157	385	1724	196			
110	1164	43	180	1309	82	250	1453	121	320	1594	160	390	1734	199			
115	1174	46	185	1320	85	255	1463	124	325	1604	163	395	1744	202			
120	1185	49	190	1330	88	260	1473	127	330	1614	166	400	1754	204			
125	1195	52	195	1340	91	265	1483	129	335	1624	168	405	1764	207			

1.13 ATO (Automatic Top-Off) Service Procedures

The automatic top-off system is activated when the oil level falls below a sensor in the rear of the frypot. The signal is sent to the ATO board to engage the solenoid to the frypot and turn on the ATO pump. The pump draws oil from the JIB (Jug In Box) to a port in the rear of the frypot. Once the oil level has satisfied the sensor, the pump and solenoid turn off.

The ATO board is located inside the box, behind the JIB (see Figure 1). The power for the ATO board is supplied from the transformer box. The power passes through the transformer inside the ATO box to the board.

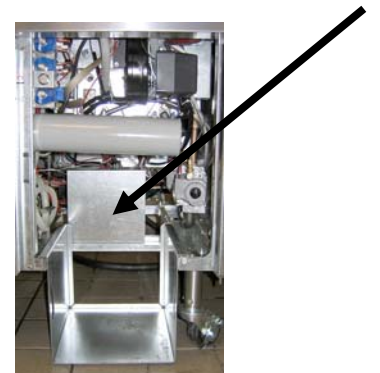

Figure 1

1.13.1 ATO (Automatic Top-Off) Troubleshooting

Problem	Probable Causes	Corrective Action
<p>The yellow JIB low light won't illuminate.</p>	<p>A. Power not present in the transformer box. B. Failed transformer. C. Loose wire connection</p>	<p>A. Ensure power is present in the transformer box. B. If power is present in transformer box, check the transformer for correct voltage. C. Ensure the yellow LED is securely attached to plug J6 on the ATO board.</p>
<p>Frypots won't top off.</p>	<p>A. Probe temperature lower than setpoint. B. Oil is too cold. C. ATO board power loss D. Failed solenoid. E. ATO pump failed or over tightened. F. Failed transformer/harness. G. Failed ATO board.</p>	<p>A. Check to see that fryer is heating. Check probe resistance. If probe is bad, replace the probe. B. Ensure that the oil in the JIB is above 70°F (21°C). C. Power to the ATO board has been cut off. Ensure the board has power and cycle ALL computers off and on to readdress system. D. Check solenoid to see if functioning properly. E. If the solenoid is working, ensure that the screws on the bottom of the pump are not too tight. Loosen the screws. If loosening the screws doesn't fix the problem, replace the pump. F. Ensure transformer in ATO box is functioning properly. Check power from transformer to ATO board. Ensure all harnesses are plugged securely into place. G. Check for proper voltages using the pin position chart found on page 1-31. If ATO found defective, replace ATO board.</p>
<p>One vat tops off but other vats fail to top off.</p>	<p>A. Failed solenoid B. Loose wire connection.</p>	<p>A. Check power to the pump. A hot pump suggests a failed solenoid. B. Ensure all wiring harnesses are securely connected to ATO board and solenoids.</p>
<p>Incorrect vat tops off.</p>	<p>A. Wired incorrectly. B. Flexlines connected to wrong vat.</p>	<p>A. Check wiring. B. Switch flexlines to correct vat.</p>

1.13.2 ATO (Automatic Top-Off) Board Pin Positions and Harnesses

Connector	From/To	Harness #	Pin #	Function	Voltage	Wire Color
J8	Solenoids	8074718 (FV) 8074717 (DV)	1	Output DV - Vat #1	Ground	Green
			2	Output FV - Vat #1		Red
			3	Output DV - Vat #2		Green
			4	Output FV - Vat #2		Red
			5	Output DV - Vat #3		Green
			6	Output FV - Vat #3		Red
	Top Off Pump JIB Reset Switch	8074719	7	Top Off Pump	16VDC	Red
			8	JIB Low Reset		Black
	Solenoids	8074718 (FV) 8074717 (DV)	9	24VAC DV - Vat #1	24VAC	White
			10	24VAC FV - Vat #1		Black
			11	24VAC DV - Vat #2		White
			12	24VAC FV - Vat #2		Black
			13	24VAC DV - Vat #3		White
			14	24VAC FV - Vat #3		Black
	Top Off Pump & JIB Reset Switch	8074719	15		16VDC	
			16	Ground		Red
J4 (Rear) / J5 (Front)	Transformer	8074553	1	24VAC Ret	24VAC	Orange
			2	24VAC		Blue
			3			
			4			
			5	12VAC Ret	12VAC	Red
			6	12VAC		Brown
			7			
			8			
J1 - Vat #1 J2 - Vat #2 J3 - Vat #3	ATO RTD	8074655 - Vat #1 8074654 - Vat #2 8074654 - Vat #3	1	DV - Probe Ground	Ohm	White
			2	DV - Probe		Red
			3	FV - Probe Ground		White
			4	FV - Probe		Red
J6	Orange LED	8074555	1	16VDC	16VDC	Black
			2	16VDC Ret		Red
J7			1			
			2			
			3	Ground		
			4	RB7/DATA		
			5	RB6/CLOCK		
J10	Network Resistor (pins 2 & 3) or to next ATO Board (4 & 5 vat units)	8074552 (Network Resistor)	1	Ground		Black
		8074546 to next ATO board.	2	CAN Lo		Red
			3	CAN Hi		White
			4			
			5			
			6			
J9	CM7 J6/J7	8074646	1	Ground		Black
			2	CAN Lo		Red
			3	CAN Hi		White
			4			
			5			
			6			

1.13.3 Replacing the ATO Board or Transformer

Disconnect the fryer from the electrical power supply. Locate the ATO box (see Figure 1 on page 1-29), behind the JIB (Jug In Box). Remove the cover to expose the transformer and ATO board (see Figure 2). Mark and unplug any wires or harnesses. Replace the defective component and reattach all wires or harnesses. Replace the cover. Once replaced, reconnect the power. Remove and restore power to ALL computers after power has been restored to the ATO board.



Figure 2

1.13.4 Replacing the ATO Pump or Solenoid

Disconnect the fryer from the electrical power supply. Locate the ATO pump and solenoid tree (see Figure 3), behind the ATO box. Mark and unplug any wires or harnesses. Replace the defective component and reattach all wires or harnesses. Once replaced, reconnect the power.



Figure 3

1.14 CM7 Computer Service Procedures

1.14.1 CM7 Computer Troubleshooting

Problem	Probable Causes	Corrective Action
No Display on Computer.	A. Computer not turned on.	A. Press the ON/OFF switch to turn the computer on.
	B. No power to the fryer.	B. If the computer power cord is not plugged in, the computer will not activate. Verify computer power cord is plugged in and that circuit breaker is not tripped.
	C. Computer has failed.	C. Swap the computer with a computer known to be good. If computer functions, replace the computer.
	D. Damaged computer wiring harness.	D. Swap with a harness known to be good. If computer functions, replace the harness.

Problem	Probable Causes	Corrective Action
	E. Power supply component or interface board has failed.	E. If any component in the power supply system (including the transformer and interface board) fail, power will not be supplied to the computer and it will not function.
Computer locks up.	Computer error.	Remove and restore power to the computer.
Heat indicator off upon initial startup. Display shows <i>HI</i> or <i>HOT</i> with alarm sounding.	Failed computer.	Replace computer.
CM7 display is in wrong temperature scale (Fahrenheit or Celsius).	Incorrect display option programmed.	See section 1.14.2 on page 1-35 to change temperature scale.
CM7 display shows <i>HOT-HI-1</i>.	Frypot temperature is more than 410°F (210°C) or, in CE countries, 395°F (202°C).	This is an indication of a malfunction in the temperature control circuitry, including a failure of the high-limit thermostat.
CM7 display shows <i>HI-LIMIT</i>.	Computer in high-limit test mode.	This is displayed only during a test of the high-limit circuit and indicates that the high-limit has opened properly.
CM7 display shows <i>LOW TEMP</i>.	Frypot temperature is between 180°F (82°C) and 315°F (157°C).	This display is normal when the fryer is first turned on while in the melt cycle mode. To bypass the melt cycle press and hold a #2 product button under the LCD display until a chirp is heard. The alarm will chirp and the computer displays EXIT MELT alternating with YES NO . Press the #1 YES button to exit melt. It may appear for a short while if a large batch of frozen product is added to the frypot. If the display never goes out, the fryer is not heating.
CM7 display shows <i>ERROR RM SDCRD</i>	Defective SD Card	Replace card with another card.

Problem	Probable Causes	Corrective Action
CM7 display shows PROBE FAILURE.	Problem with the temperature measuring circuitry including the probe.	This indicates a problem within the temperature measuring circuitry. Check resistance of probe, if faulty replace probe.
CM7 display shows PROBE FAILURE with alarm sounding.	Damaged computer wiring harness or connector.	Swap the computer wiring harness with one known to be good. If problem is corrected replace the harness.
CM7 display shows IGNITION FAILURE.	Open drain valve, failed computer, failed interface board, open high-limit thermostat.	Is displayed if the fryer loses its ability to heat oil. It is also displayed when the oil temperature is above 450°F (232°C) and the high-limit thermostat has opened, halting the heating of the oil.
Computer will not go into program mode or some buttons do not actuate.	Failed computer.	Replace computer
CM7 display shows LOW TEMP, heating indicator cycles on and off normally but fryer does not heat.	A. Failed computer. B. Damaged computer wiring harness.	A. Replace computer. B. Replace computer wiring harness.
CM7 display shows IGNITION FAILURE with alarm sounding. Heating indicator is on, but fryer is not heating.	Drain valve not fully closed.	Press the reset switch on the MIB board. All drain valves should close. Using the ON/OFF switch, turn the computer OFF and then ON again.
CM7 display shows IGNITION FAILURE and alarm sounds, but fryer operates normally (false alarm).	Failed computer.	Replace computer.
CM7 display shows HI 2 BAD.	Computer in high-limit test mode.	This is displayed only during a test of the high-limit circuit and indicates that the high-limit has failed.

Problem	Probable Causes	Corrective Action
CM7 display shows software for only CM7.	Loose or damaged harness	Check that all harnesses between CM7's and ATO are secure. Check for loose pins. If the problem persists, swap out computer from one bank to another and reinitialize.

1.14.2 CM7 Useful Codes

To enter any of the following codes: Press the **UNLOCK ▼** button three times. **TECH** is displayed. Press the **✓** button. **CODE** is displayed. Enter a code listed below for the appropriate function.

- **Enter Setup in Tech Mode – Enter 7378.**
- **Change from F° to C° - Enter 1658.** The computer displays **OFF**. Turn the computer on and check temperature to see the temperature scale. If the desired scale is not displayed, repeat.
- **Reset Factory Menu - Enter 3322.** The computer display flashes and quickly counts from 1-40 and switches to **OFF**. (**NOTE:** This will delete any manually entered menu items).
- **Reset BADCRC Message -** Disconnect board locator plug (J10). Reinsert plug. Enter **9988**. Computer display switches to **OFF**. Remove and then restore power to the computer using the 20-pin plug.
- **Reset RECOVERY FAULT CALL SERVICE – Enter 0042.**
- **Reset CALL TECH Message -** Disconnect board locator plug (J10). Reinsert plug. Enter **1000**. Computer display switches to **OFF**. Remove and then restore power to the computer using the 20-pin plug. If this message appears at any time other than after upgrade from a previous version, replace the computer

PASSWORDS

Program Mode: Press the **UNLOCK ▼** button once. The computer displays **PROGRAM**. Press the **✓** button. **ENTER CODE** is displayed. Enter **1650**.

Manager Mode: Press the **UNLOCK ▼** button twice. The computer displays **MANAGER**. Press the **✓** button. **ENTER CODE** is displayed. Enter **4321**.

Tech Mode: Press the **UNLOCK ▼** button three times. The computer displays **TECH**. Press the **✓** button. **CODE** is displayed. Enter **7378**.

1.14.3 CM7 Menu Summary Tree

Reflected below are the major programming sections in the CM7 and the order in which submenu headings will be found under the sections in the Installation and Operation Manual.

Adding New Menu Items	See section 4.10.2
Storing Menu Items in Product Buttons	See section 4.10.3
Temperature Conversion from F° to C°	See section 4.10.4

CM7 Programming Menu

Programming	
└─ Program Mode.....	4.11
[With the fryer OFF, press the UNLOCK button once, displays <i>PROGRAM</i> . Press the ✓. Enter 1650]	
└─ Setpoint Temperature.....	4.11.1
└─ Product Selection.....	4.11.2
└─ Name	
└─ Cook Time	
└─ Cook ID	
└─ Shake Time	
└─ Hold Time	
└─ Filt After	
└─ Sensitivity	
└─ Assign Btn	
└─ Boil Out Mode.....	4.11.3
└─ Manager Mode.....	4.12
[With the fryer OFF, press the UNLOCK button twice, displays <i>MANAGER</i> . Press the ✓. Enter 4321]	
└─ E-Log	
└─ Alert Tone	
└─ Volume 1-9	
└─ Tone 1-3	
└─ Tech Mode.....	4.9
[With the fryer OFF, press the UNLOCK button three times, displays <i>TECH</i> . Press the ✓. Enter 7378]	
└─ Setup	
└─ Fryer Setup	

1.14.4 CM7 Board Pin Positions and Harnesses

Connector	From/To	Harness PN	Pin #	Function	Voltage	Wire Color
J2	Interface Board to Computer	8074199 SMT Computer to Interface Board Harness	1	12VAC In	12VAC	Black
			2	Ground		
			3	12VAC In	12VAC	
			4	FV Heat Demand		
			5	V Relay	12VDC	
			6	DV Heat Demand		
			7	R/H B/L	12VDC	
			8	Analog Ground		
			9	L/H B/L	12VDC	
			10	ALARM		
			11	Sound Device	5VDC	
			12	ALARM		
			13	FV Probe		
			14	Common Probes		
			15	DV Probe		
J6	Previous CM7 J7 or Network Resistor 807-4552	8074546 Computer Communication Harness	1	Ground		Black
			2	CAN Lo		Red
			3	CAN Hi		White
			4			
			5			
			6			
J7	ATO J1 or Next CM7 J6	8074546 Computer Communication Harness	1	Ground		Black
			2	CAN Lo		Red
			3	CAN Hi		White
			4			
			5			
			6			
J9						
J10	Interface Board Ground to Computer	8074573 Computer Locator Harness	1	Vat #1		Black
			2	Vat #2		
			3	Vat #3		
			4	Vat #4		
			5	Vat #5		
			6			
J11	SD Card					

1.15 Loading and Updating Software Procedures

Loading Software from an SD card to an CM7 Computer and ATO Board

To update CM7 and ATO software follow these steps:

1. Switch all computers to **OFF**. Press the TEMP button to check current CM7/ATO software version.
2. Remove the two screws on the left side cover plate of the CM7 computer.
3. With the computer folded down, insert the SD card, with the contacts facing down and the notch on the bottom right (see Figure 4 and 5), into the slot on the left side of the CM7.
4. Once inserted, **FWUPD** appears on the left display and **SCCRCK** on the right. Numbers count up on the right display.
5. The display then changes to **FWLOAD** on the left; numbers count up on the right.
6. The computer displays **OBFCRC**. If updating ATO software, the computer will display **FWU ATO** on the left and will count down from 2500 on the right.
7. When the update is complete the CM7 displays **DONE** on the left and **RM SDCRD** on the right.
8. Remove the SD card using the fingernail slot on the top of the SD card.
9. Repeat steps 1-8 for all computers.
10. Remove **ALL** power from the fryer on the rear of the unit.
11. Restore power to the fryer. There is short delay prior to the computer powering up and displaying **OFF**.
12. With the computer displaying **OFF**, verify software update by pressing the **TEMP** button to check updated CM7/ATO version.



Figure 4

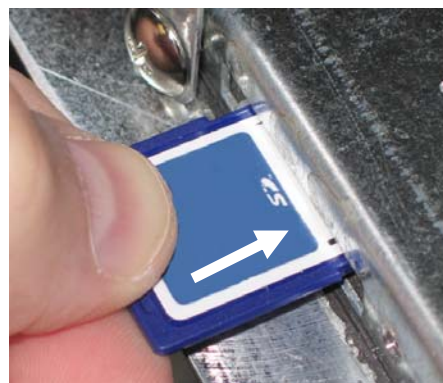
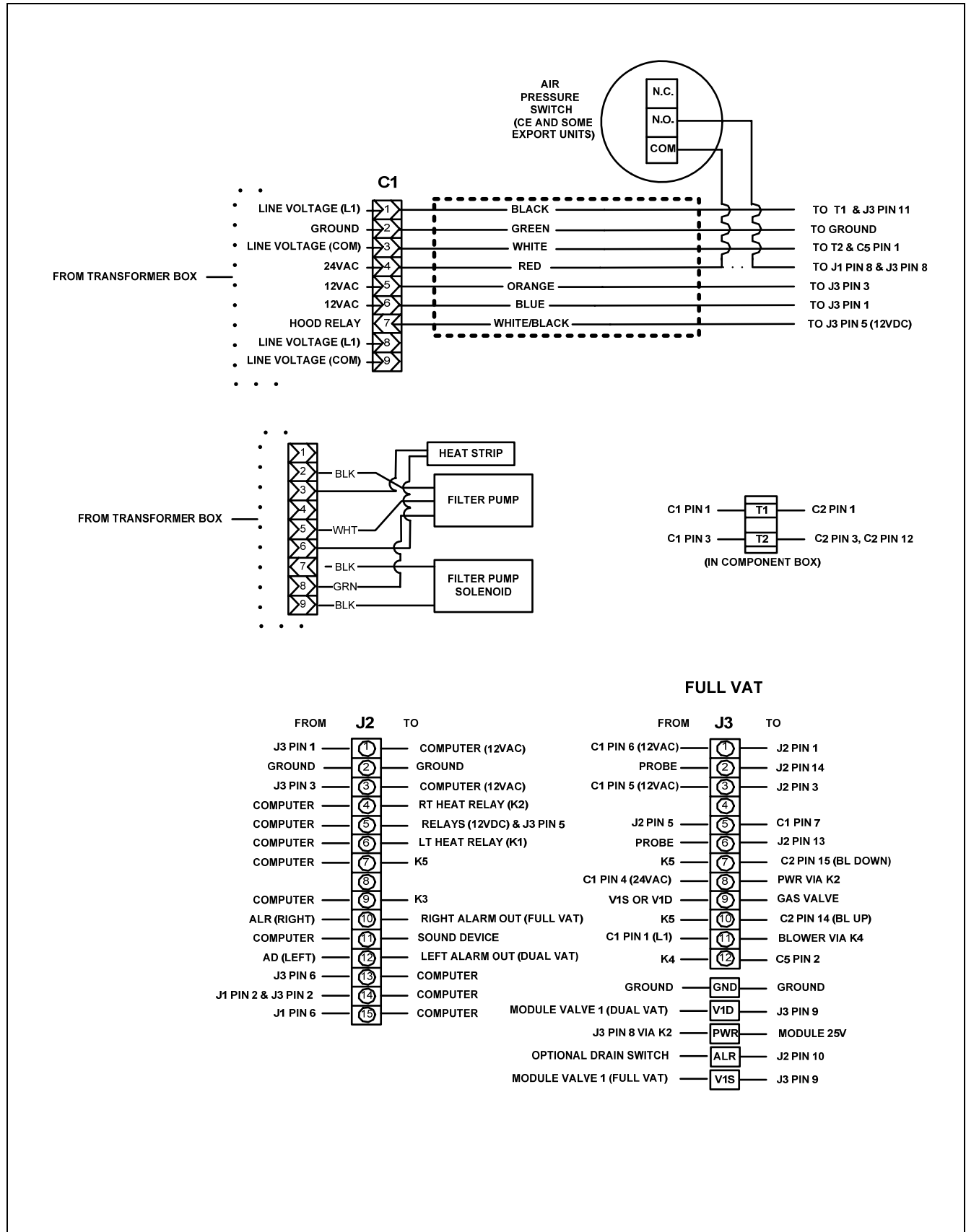

Figure 5

1.16 Principal Wiring Connections



1.17 Wiring Diagrams

1.17.1 Main

The Heat Strip is not present here on 330's.

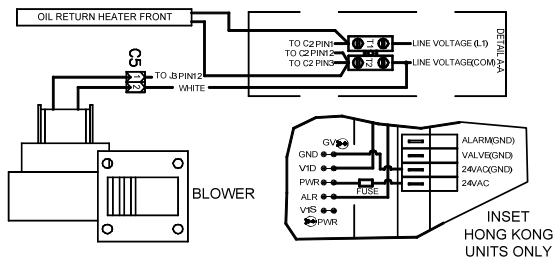
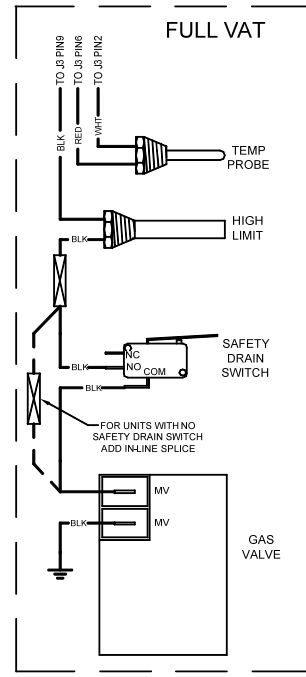
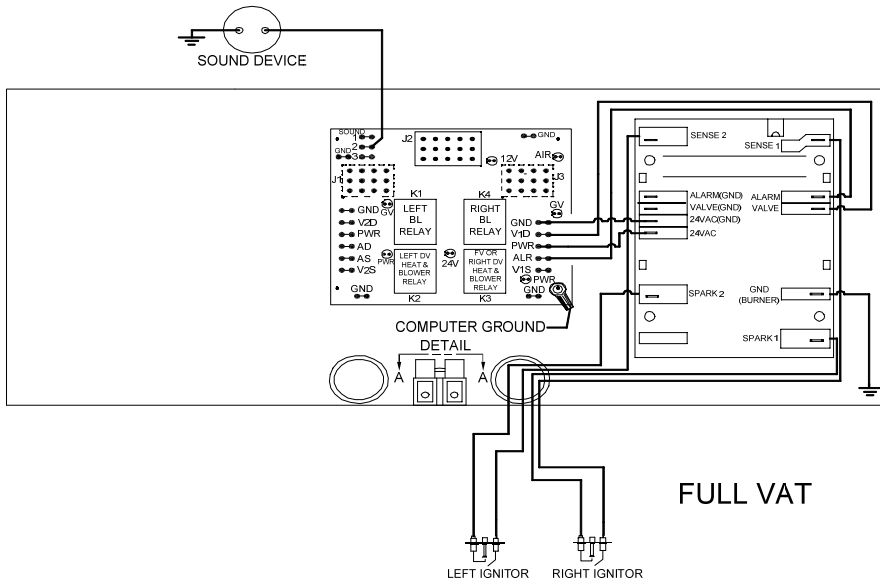
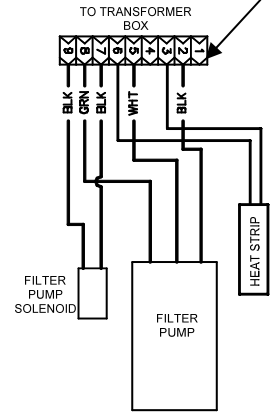
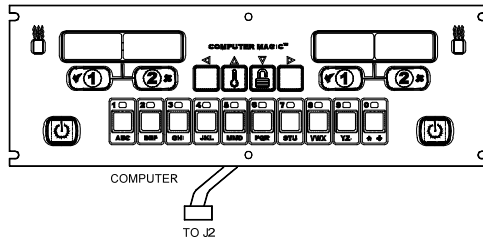

8051315C/ 8051526C

Refer to "PRINCIPAL WIRING CONNECTIONS" on Page 1-39 for detail of connection points J1, J2, J3.

1.17.2 Transformer / Filter Boxes

1.17.2.1 FPGL230 and 430 Transformer / Filter Box (Domestic)

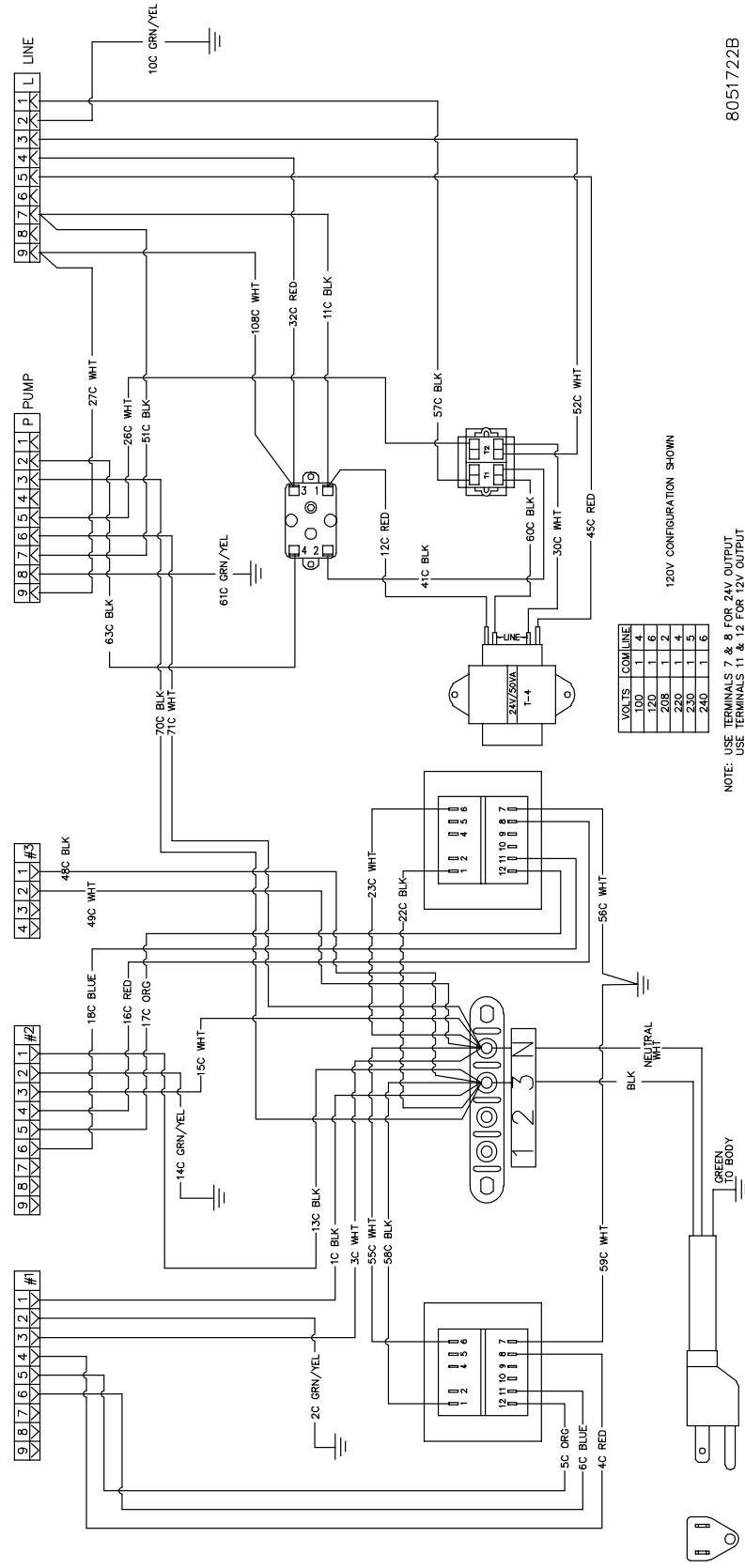

8051722B

1.17.2 FPGL330 Transformer / Filter Box (Domestic)

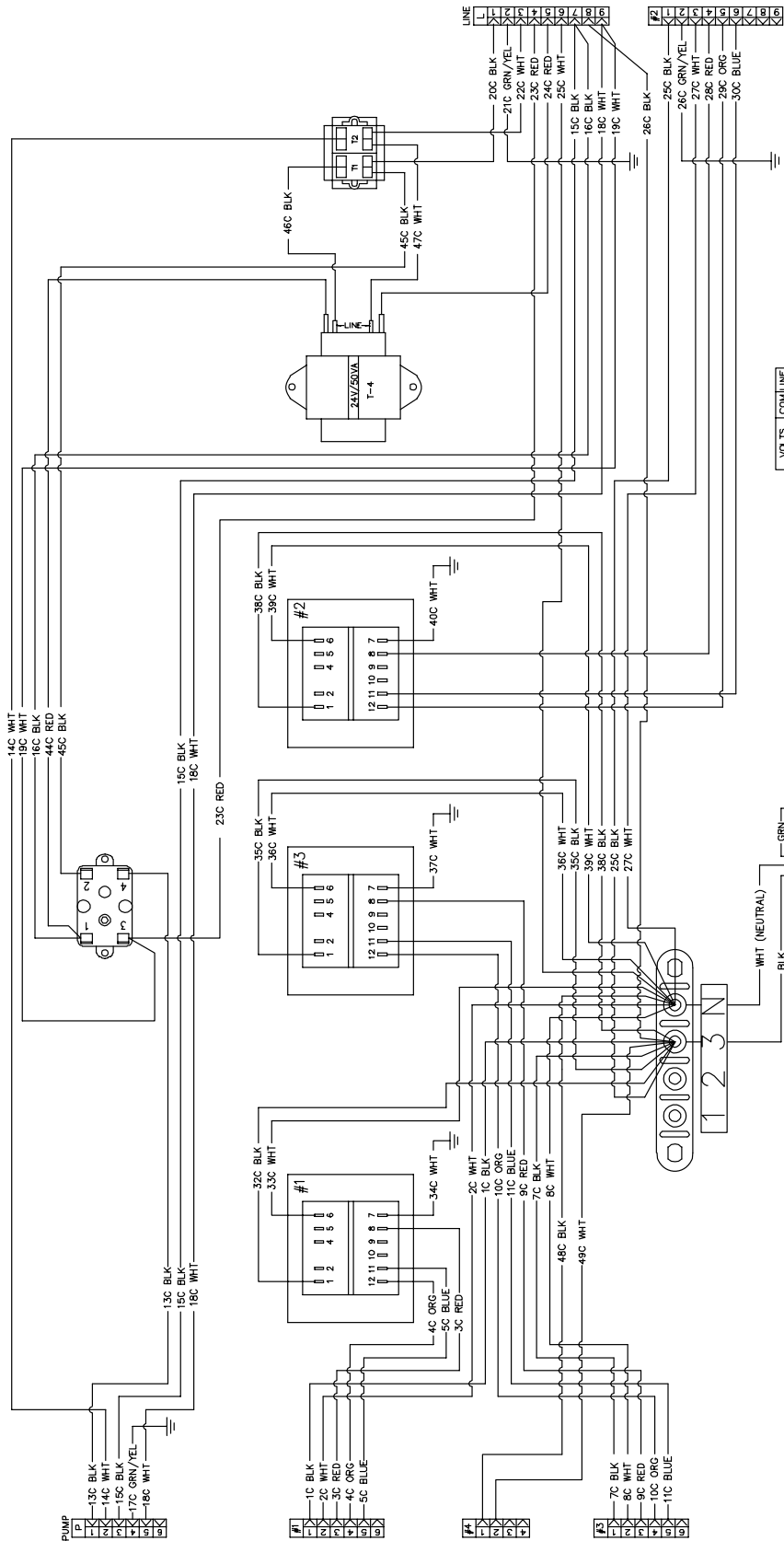

VOLTS	COMLINE
100	1 4
120	1 6
208	1 2
220	1 5
240	1 6

NOTE: USE TERMINALS 7 & 8 FOR 24V OUTPUT
 USE TERMINALS 11 & 12 FOR 12V OUTPUT

8051721B

1.17.3 Modular Basket Lift (100/120V)

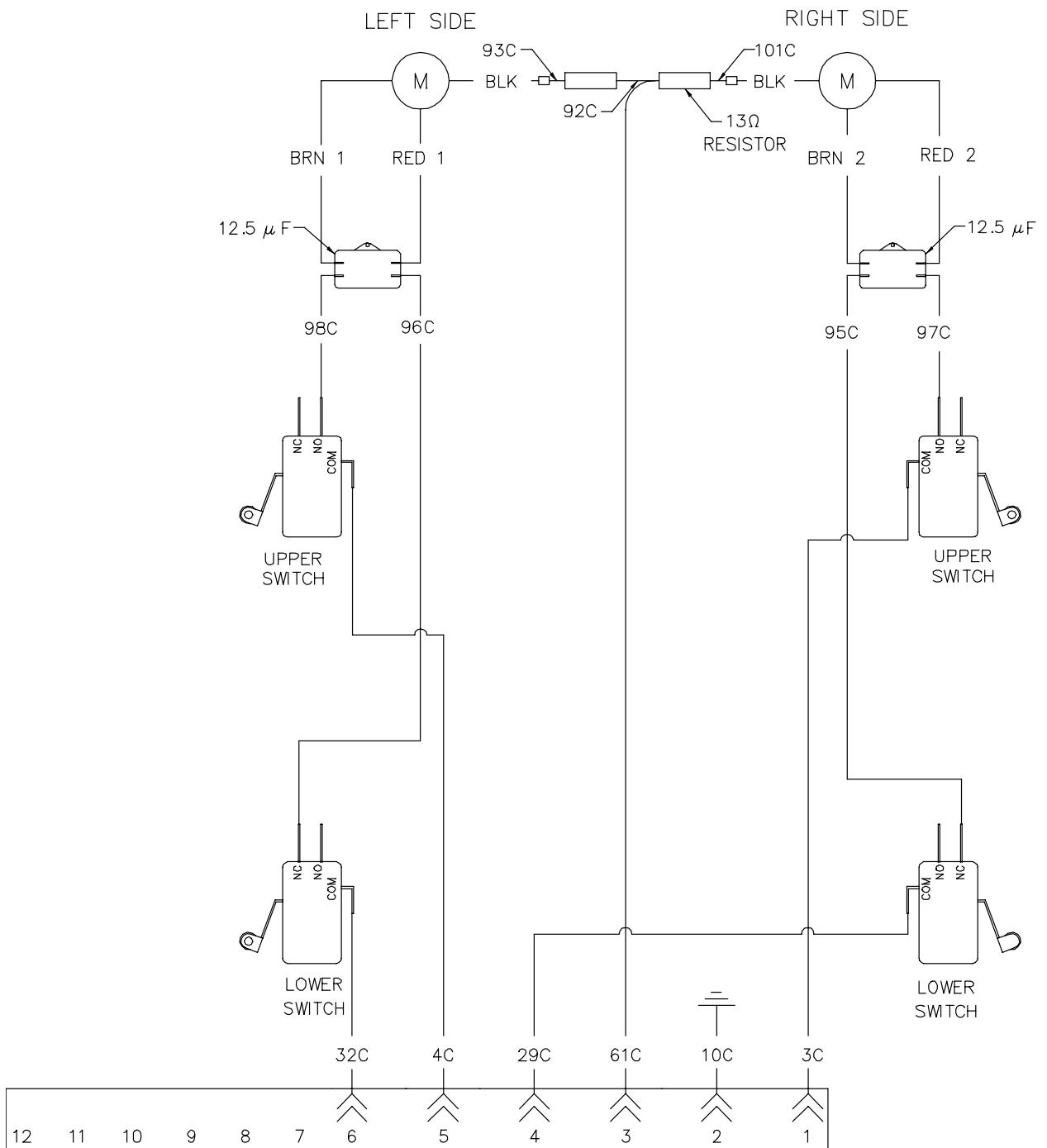

REFERENCES TO LEFT & RIGHT ARE
FROM THE REAR OF THE FRYER

8050518E

1.17.4 Modular Basket Lift (208/250V)

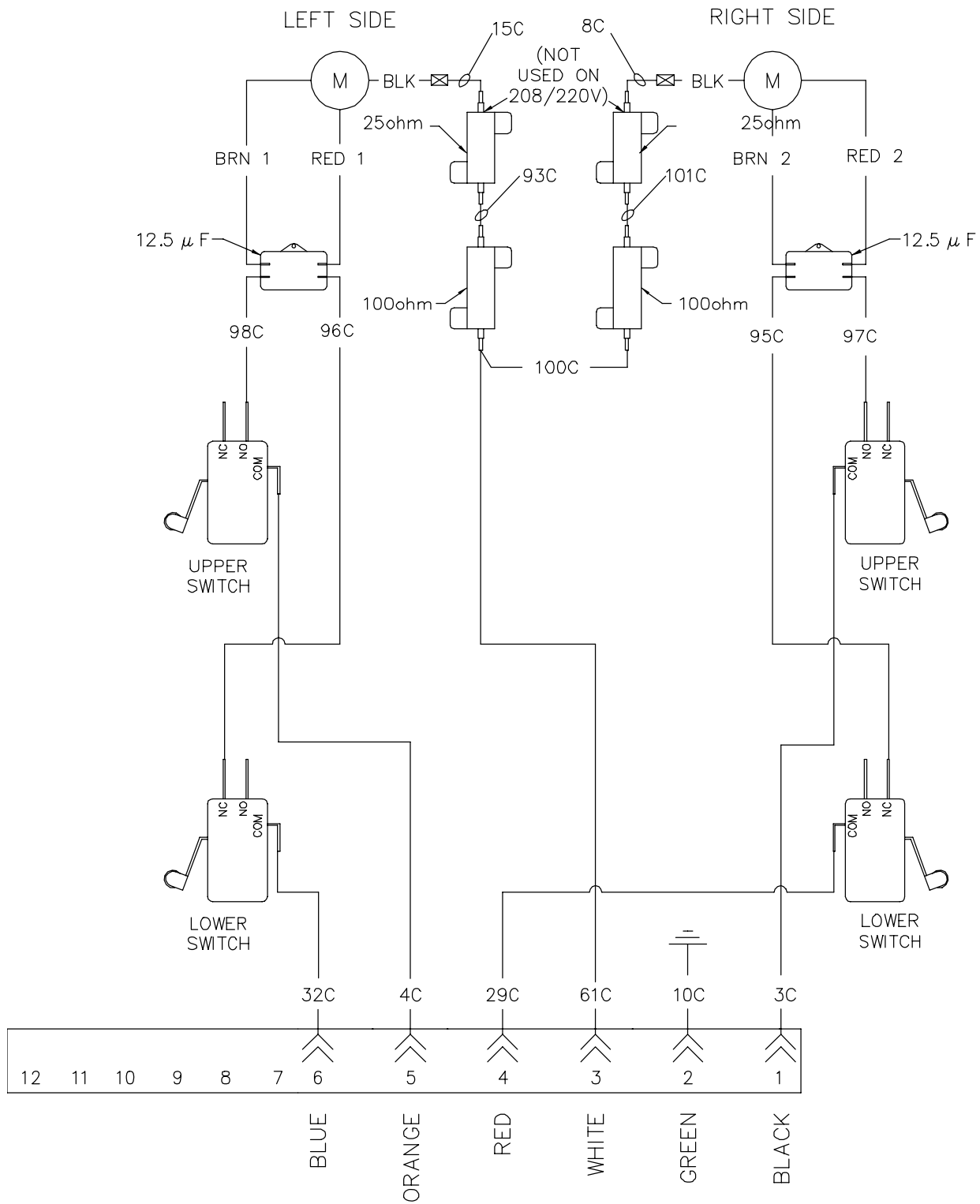

8050946B

1.18 Simplified Wiring Diagrams

1.18.1 FPGL30 Series Full Vat

FPGL30 SERIES – FULL-VAT WITH ONE DUAL-SPARK IGNITION MODULE (ONE DUAL FUNCTION HEAT/BLOWER RELAY (K3))

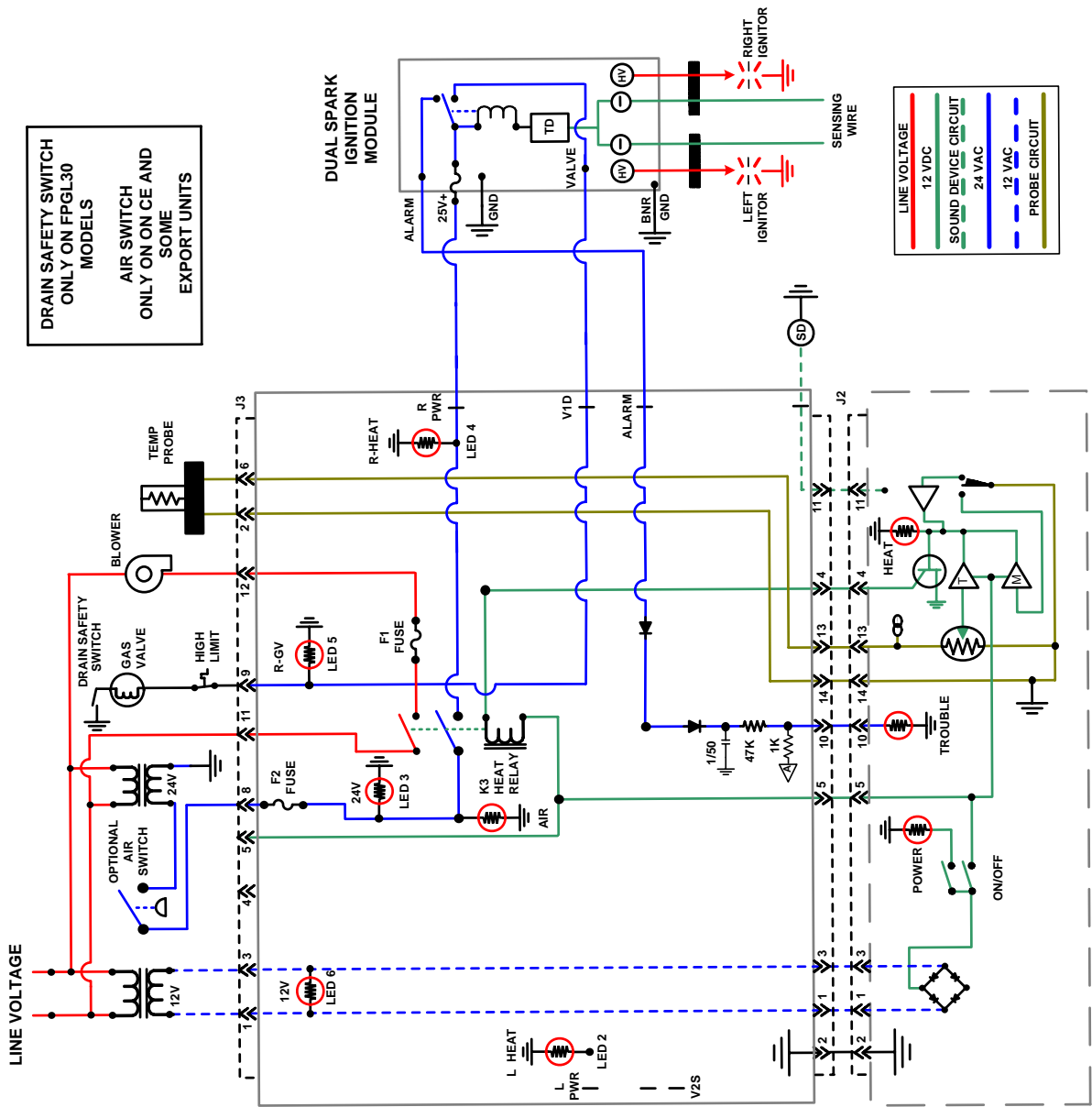

1.18.2 FPGL30 Series Full Vat (Australia and Pacific Rim)

FPGL30 SERIES – FULL-VAT – AUSTRALIA AND PACIFIC RIM

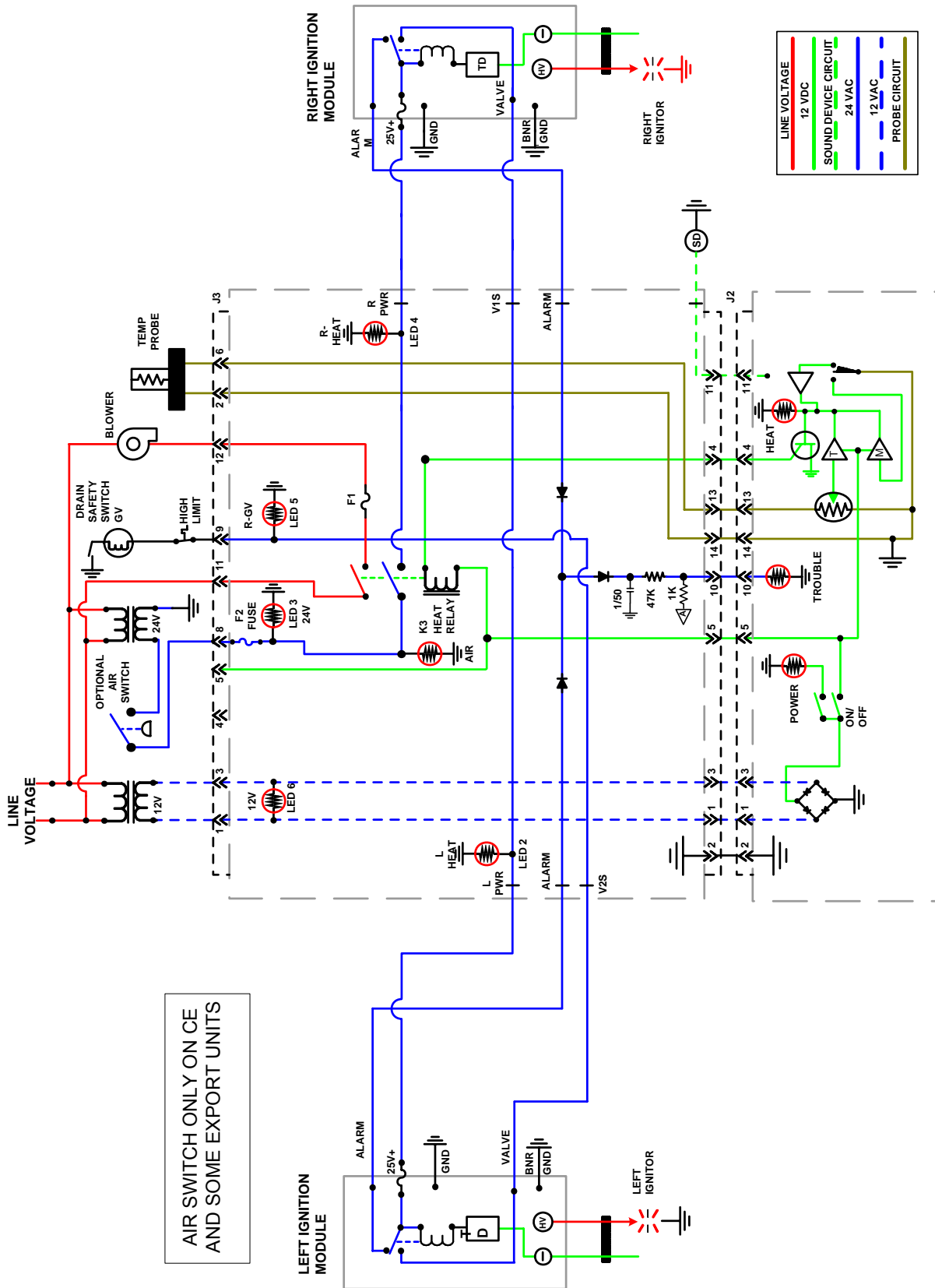

1.18.3 FPGL30 Series Simplified Wiring

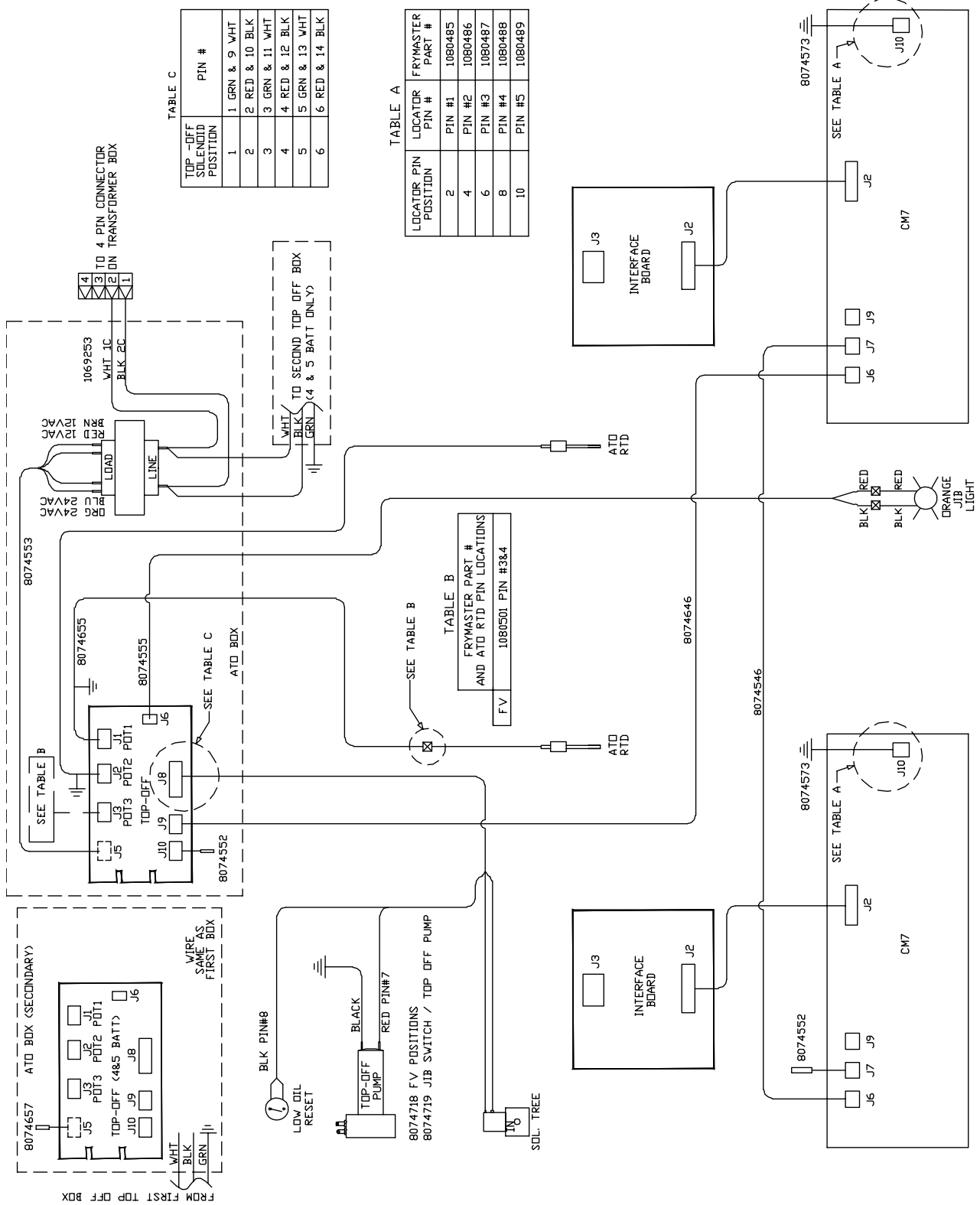

8051727D

1.18.4 FPGL30 Series Data Network Flowchart

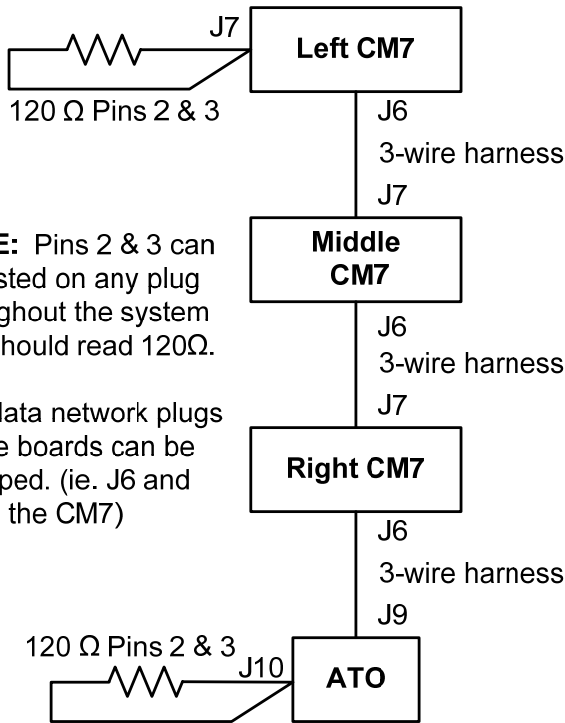

NOTE: Pins 2 & 3 can be tested on any plug throughout the system and should read 120Ω.

The data network plugs on the boards can be swapped. (ie. J6 and J7 on the CM7)

Harness	Pin #	Function	Voltage	Wire Color
3-wire harness	1	Ground		Black
	2	CAN Lo		Red
	3	CAN Hi		White
	4	NOT USED		
	5			
	6			

PROTECTOR® SERIES GAS FRYERS

CHAPTER 2: PARTS LIST

2.1 Accessories

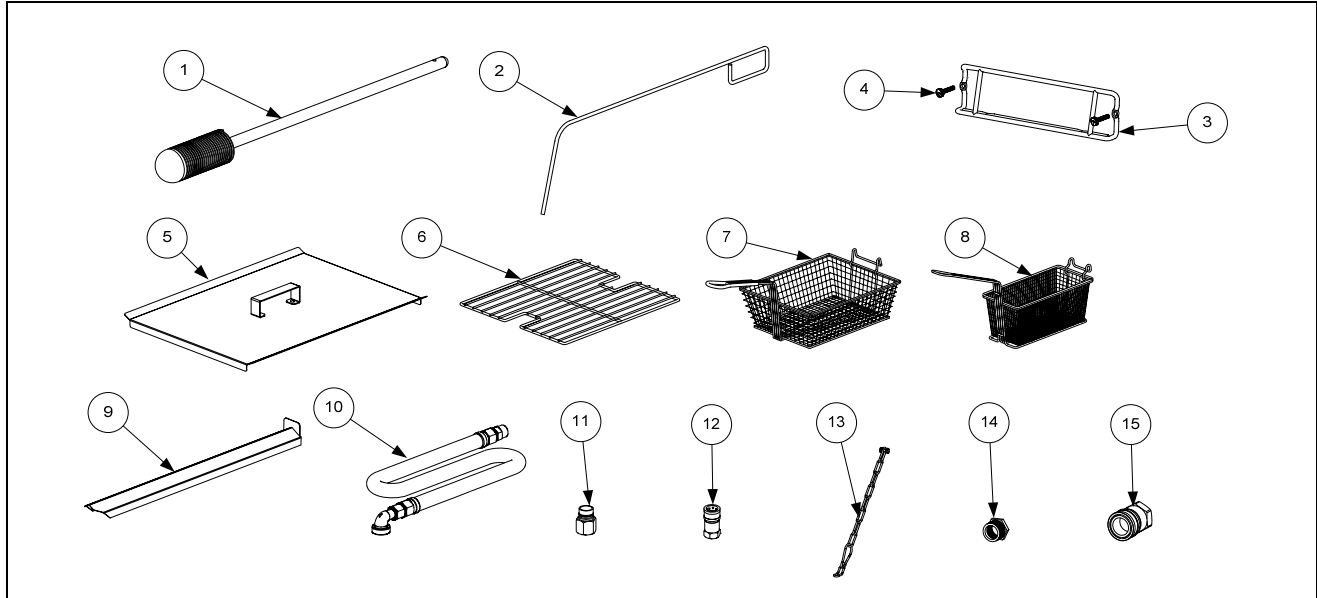

ITEM	PART #	COMPONENT
1	803-0209	Brush, Frypot
2	803-0197	Cleanout Rod, 27-inch
3	810-2793	Hanger, Basket
4	809-0171	Thumbscrew, ¼-20 X 1½-inch Universal Hood (use 809-0921 for Spacer)
5	106-8930	Cover, Frypot, Full Vat
*	826-0993SP	Handle Kit, Frypot Cover (includes handle and screws)
6	803-0375	Basket Support Rack, Full Vat
*	803-0136	Basket Support Screen, Full Vat (screen w/handle used in place of Item 6)
7	803-0099	Basket, Full-Vat
8	803-0271	Basket, Dual-Vat (Twin)
9	230-2975	Connecting Strip, Frypot
10	810-0478	Gas Line, 1-Inch Dormont Flexible
	806-1698SP	36-Inch (for gas line only (w/o Items 11 and 12), use 810-0088)
	806-1699	48-Inch (for gas line only (w/o Items 11 and 12), use 810-0085)
11	810-0074	Quick-Disconnect Fitting, 1-Inch Male
12	810-0073	Quick-Disconnect Fitting, 1-Inch Female
13	826-0900	Kit, Chain Restraint
14	826-1045	Bushing, Flexible Gas Line (813-0032)
15	810-0070	Coupling, Gas Line Female Quick Disconnect ¾-inch
	810-0073	Coupling, Gas Line Female Quick Disconnect 1-inch
*	803-0170	Filter Pack, Paper – 100 Sheets
*	803-0002	Powder, Filter – 80- 1-Cup Application Packages
*	826-1157	Kit, Fuse and Fuse Puller (2 Fuses)

* Not illustrated.

2.2 Basket Lift Assembly and Associated Parts

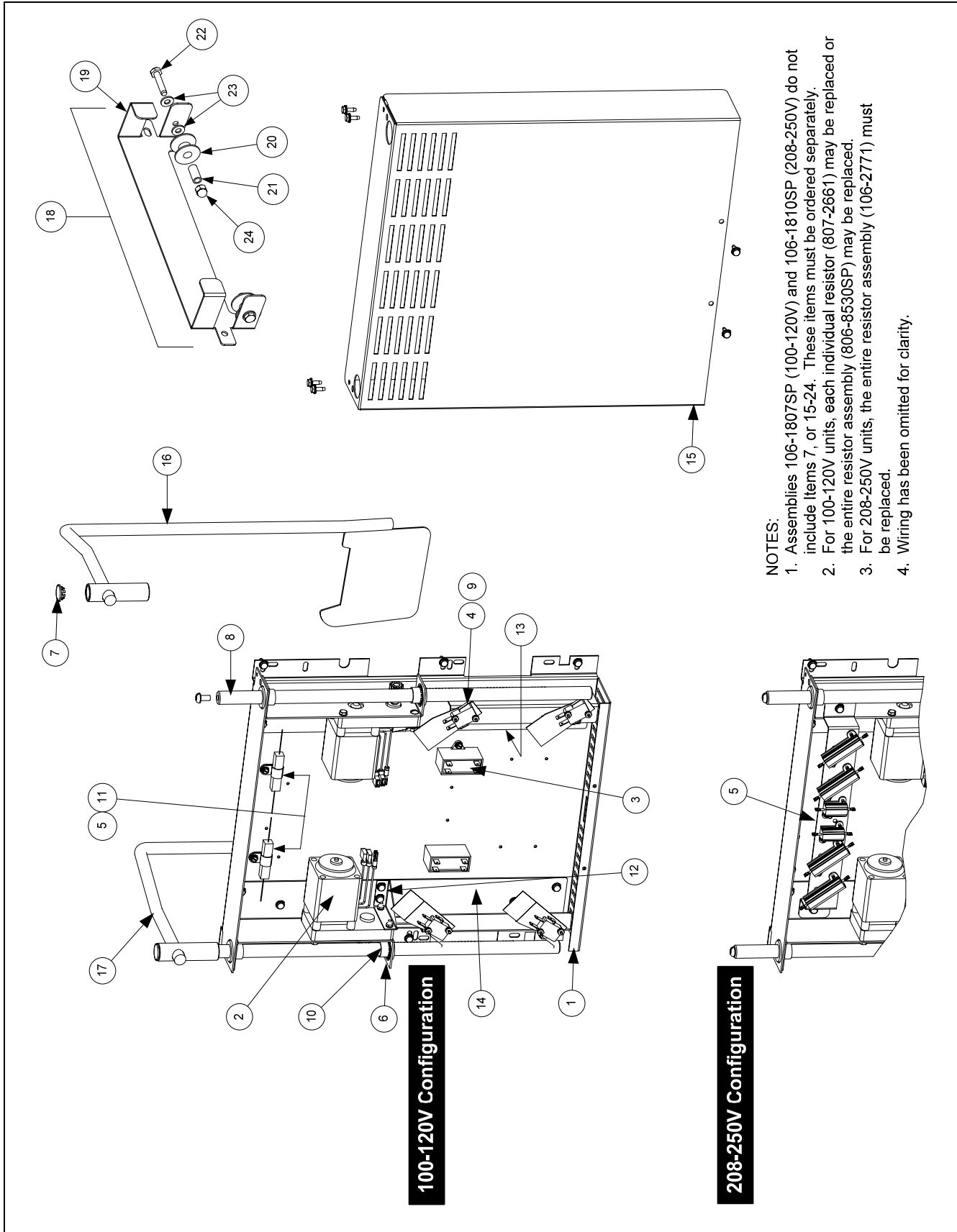

2.2 Basket Lift Assembly and Associated Parts cont.

ITEM	PART #	COMPONENT
1	200-2942	Mount, Modular Basket Lift
2	806-5964SP	Motor Assembly, Modular Basket Lift
3	807-2133	Capacitor, 12.5 μ Farad, 250VAC Motor Run
4	807-2572	Microswitch
5		Resistor Assembly
	806-8530SP	100-120V Modular Basket Lift (<i>see Note 2 in illustration</i>)
	106-2771	208-250V Modular Basket Lift
6	809-0082	Ring, Truarc Retaining
7	810-0172	Plug, 5/8-inch Stainless Steel Hole
8	810-1012	Rod, Modular Basket Lift
9	812-0442	Insulation, Microswitch
10	813-0035	Bushing, Bronze, .640" ID
11	816-0033	Tie Wrap, Screw Mount
12	900-5529	Gusset, Modular Basket Lift Motor
13	901-8499	Chassis, Modular Basket Lift, Left
14	902-8499	Chassis, Modular Basket Lift, Right
15	910-4776	Cover, S/S Modular Basket Lift (<i>for CRS cover use 900-4776</i>)
16	823-06931	Rod Assembly, Left Basket Lift
17	823-06932	Rod Assembly, Right Basket Lift
18	806-9257SP	Roller Assembly, Basket Lift
19	910-8284	Bracket, Basket Lift Roller
20	810-0194	Roller, Basket Lift
21	810-0374	Spacer, Basket Lift Roller
22	809-0508	Bolt, 1/4-20 X 1 1/4-inch
23	809-0190	Washer, 1/4-inch Flat
24	809-0047	Nut, 1/4-20 Cap
*	807-0159	Connector, 12-Pin Panel Mount
		Wire Assemblies
*	106-1822SP	For 100-120V Modular Basket Lift
*	106-1804SP	For 208-250V Modular Basket Lift
		Basket Lift Assemblies (<i>see Note 1 in illustration</i>)
*	106-1807SP	100-120V w/o Relay
*	106-1810SP	208-250V w/o Relay

* Not illustrated.

2.3 Doors, Sides, Flue Caps, Top Caps and Casters

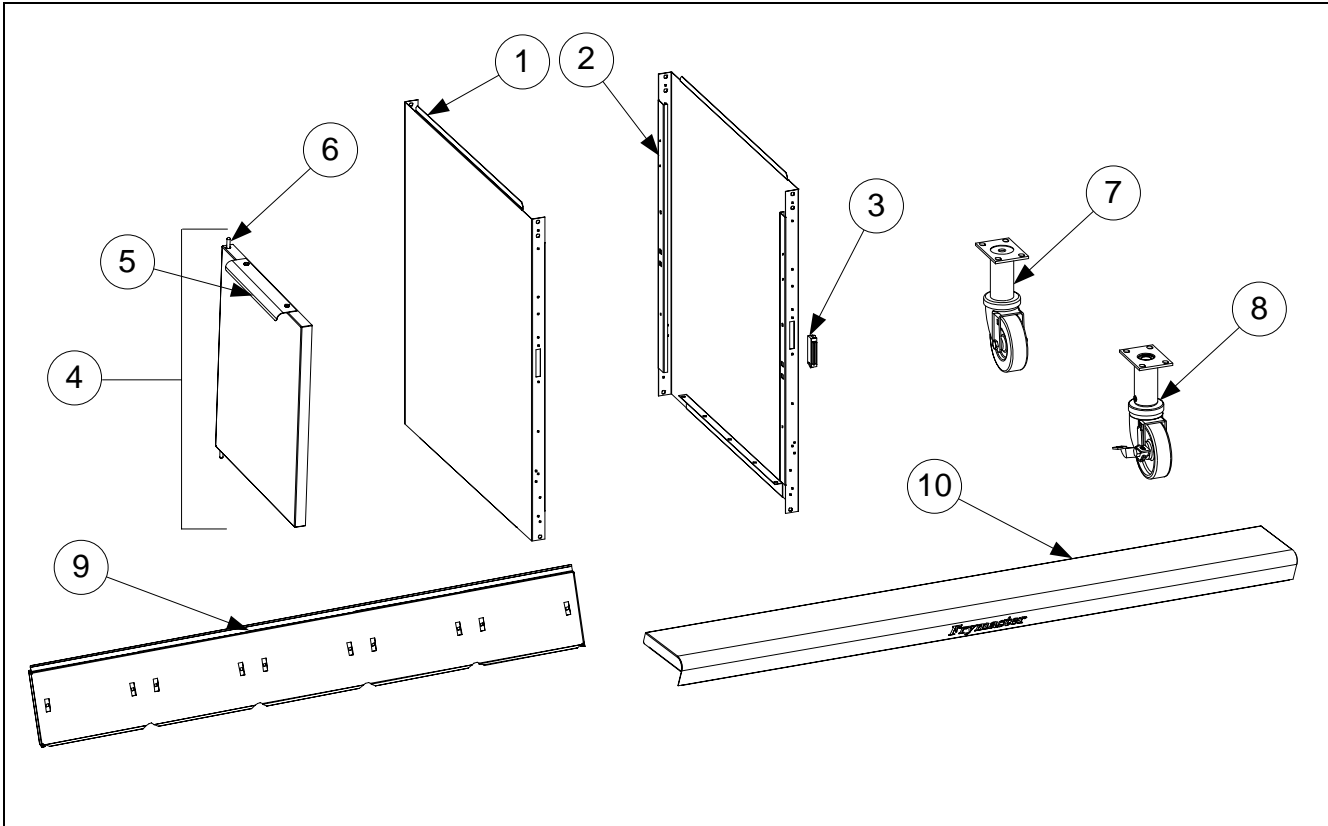

ITEM	PART #	COMPONENT
1	211-6510	Side, Standard Cabinet Left SS (use 221-0323 for Enameled Steel)
2	212-6510	Side, Standard Cabinet Right SS (use 222-0323 for Enameled Steel)
3	810-1105	Magnet, Door (vertical) (use 810-2346 for horizontal over filter pan)
4	106-4397	Door, Left or Right (Left shown – move handle to bottom for right)
5	230-4960	Handle, Eurolook Door
6	106-4067	Pin Assembly, Door
*	810-0275	Spring, Door Pin
*	809-0970	Retaining Ring
*	230-4685	Hinge, Door Lower
7	810-1494	Caster without Brake
8	810-2970	Caster with Brake
9		Flue Cap-Stainless Steel
	823-6325	Two Station Fryer
	106-7977	Three Station Fryer
	106-8955	Four Station Fryer
10		Top Cap
	824-1846	Two Station Fryer
	823-6289	Three Station Fryer
	823-6591	Four Station Fryer

* Not illustrated.

2.4 Drain System Components

2.4.1 Drain Valves and Associated Parts

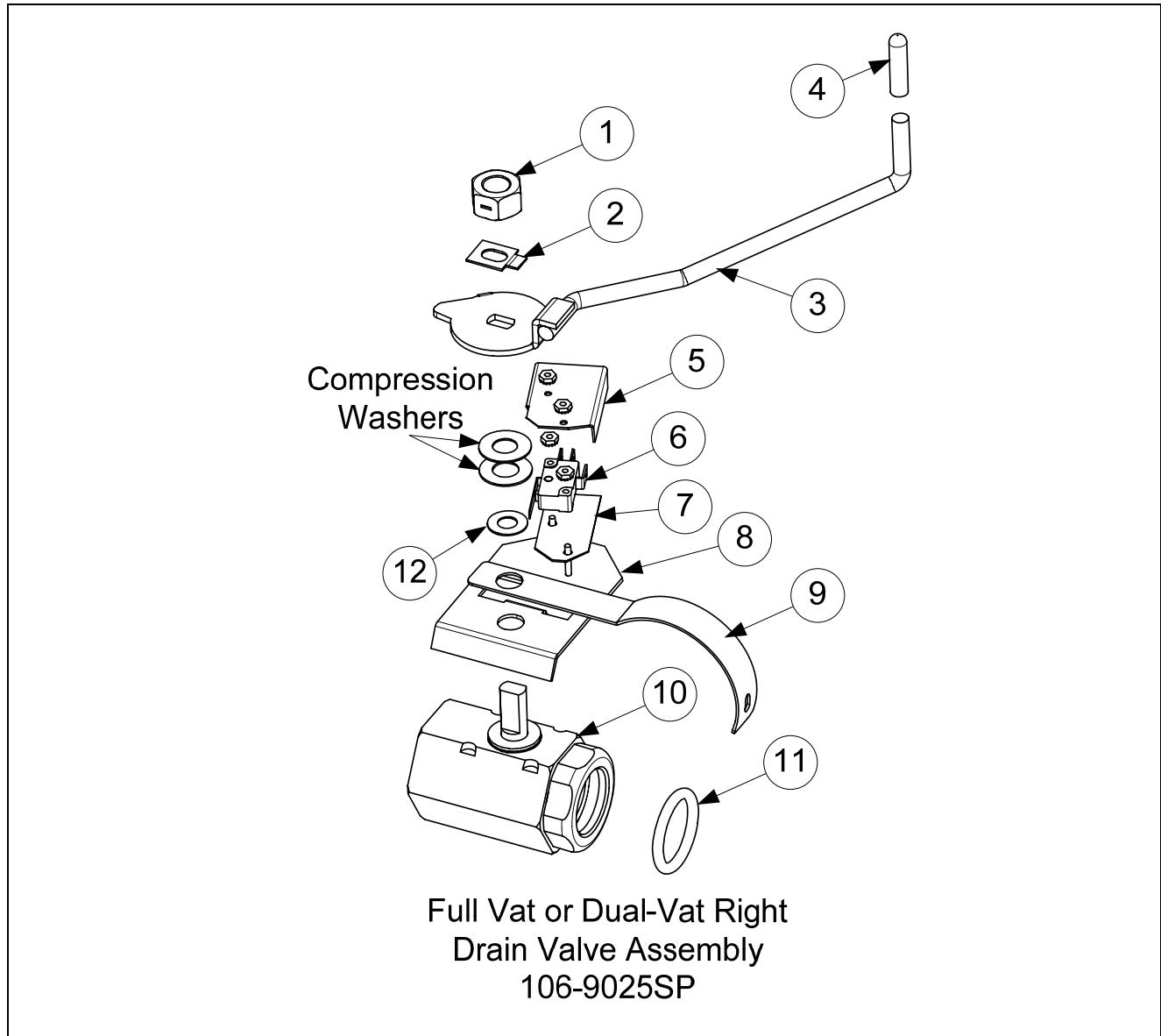

ITEM	PART #	COMPONENT
1	809-0540	Nut, ½-13 2-Way Hex Lock
2	900-2936	Retainer, Nut Drain Valve
3	810-3350	Handle, Drain Valve FV
4	810-0677	Grip, Drain Handle
5	901-2348	Cover, Safety Switch
6	807-2103	Switch, Micro
7	816-0220	Insulation, RF Switch
8	806-8137	Bracket, Switch Drain Assy
9	200-6496	Support, Drain 3" Tube
10	810-1018	Valve, 1¼-inch Drain
11	816-0135	O-Ring, Round Drain Seal
12	810-1165	Washer, Teflon Drain Valve

2.4.2 Drain Tube Sections and Associated Parts

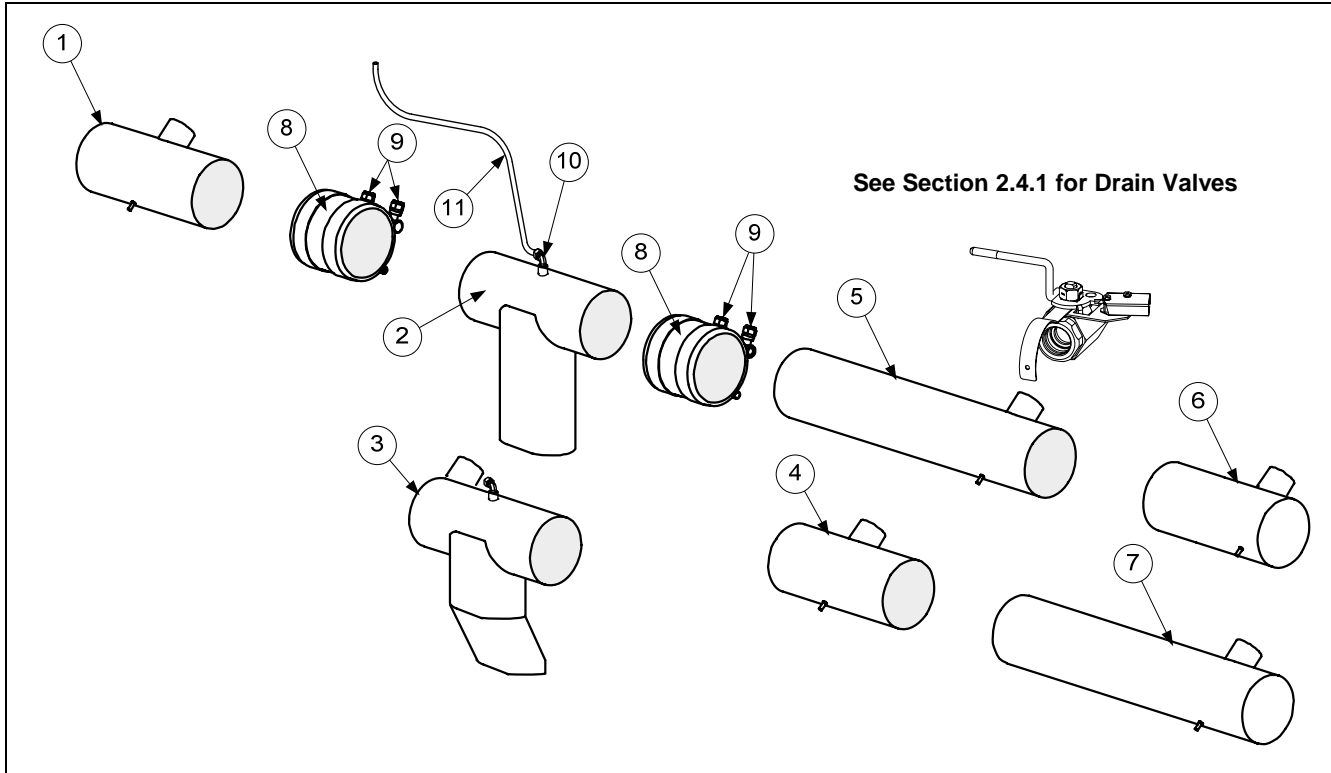

ITEM	PART #	COMPONENT
1	823-6610 4625	Drain Tube, Full-Vat Left Closed/Right End Open
2	823-6467	Drain Tube, Dump GL30
3	823-6615	Drain Tube, Dump GL230
4	823-6611	Drain Tube, Full-Vat Right, Left, Open/Right End Open
5	823-6612	Drain Tube, Full-Vat Center, Left Open/Right End Open
6	823-6614	Drain Tube, Full-Vat GL230 Right, Left Open/Right Closed Short
7	823-6613	Drain Tube, Full-Vat Right, Left Open/Right Closed Long
8	816-0772	Sleeve
9	809-0969	Clamp
10	810-2493	Elbow, 1/4-inch x 90° Tube Compression
11	811-1071	Tube, 1/4-inch OD Teflon Manifold Vent
*	816-0630	Vinyl Cap

* Not illustrated.

2.5 Electronics and Electrical Components

2.5.1 Component Boxes

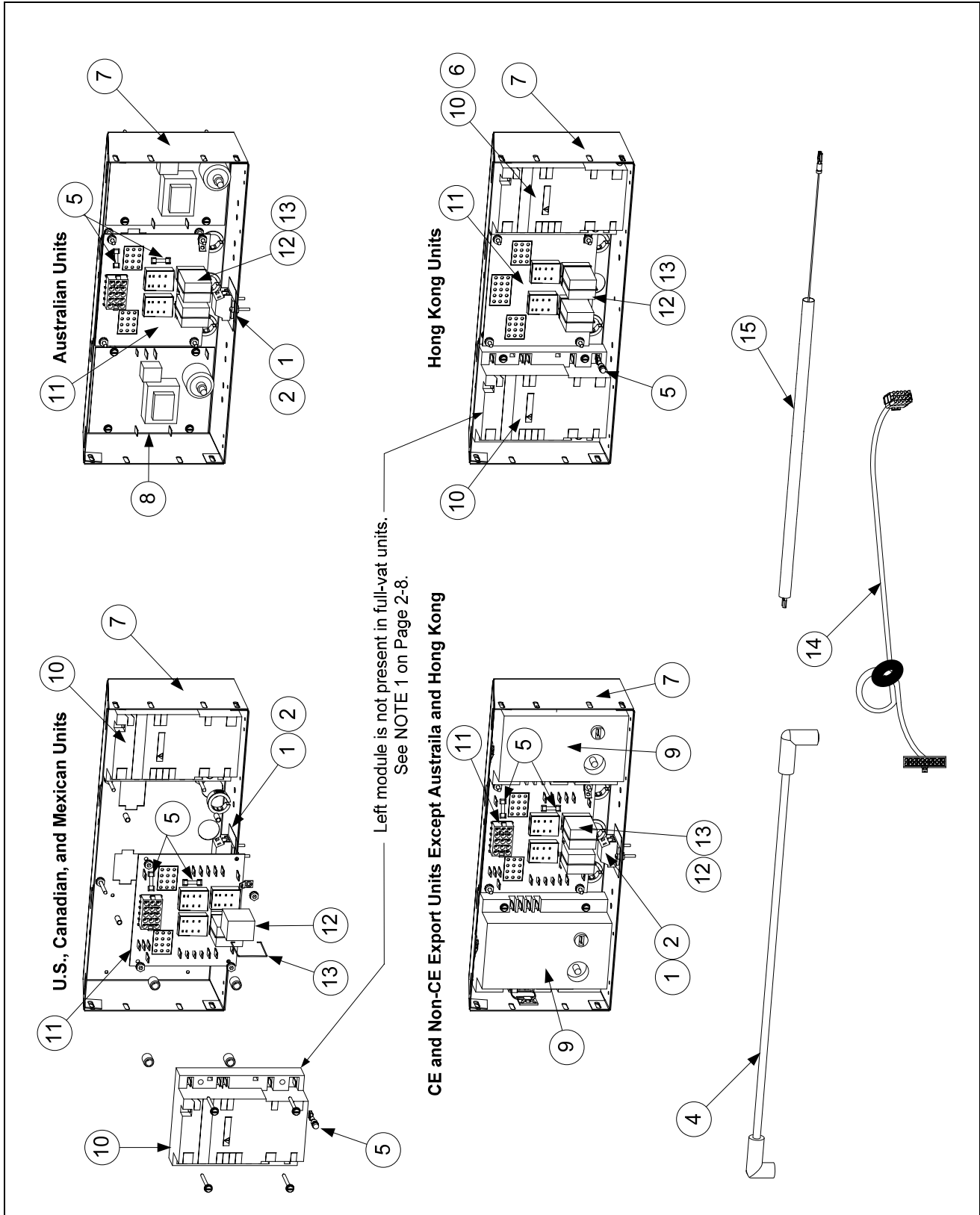

2.5.1 Component Boxes cont.

ITEM	PART #	COMPONENT
1	810-1164	Block, One-Piece Screwless Terminal
2	816-0217	Insulation, Terminal Block Paper
3	807-3843	Fuse 3A 250V Domestic
	807-3293	Fuse 5A 125V International Only
4	807-3483	Cable, 21-inch Ignition – For 807-3366/3365 Modules
*	826-2024	Cable, Ignition - 1 wire / 1 Rajah
*	826-1721	Cable, Ignition - 2 wire / 2 Rajah
*	807-1878	Cable, Ignition 19” (<i>CE and Australia</i>)
*	807-1200	Cable, Ignition 27”
5	807-3484	Connector, Rajah
6	106-0531SP	Fuse Assembly, Inline
*	826-1157	Kit, Fuse and Fuse Puller (2 Fuses)
7	200-5996	Box, One-Piece Component
8	807-2971	Ignition Module, (<i>Australia</i>)
9	807-1006	Ignition Module, CE and Non-CE export (<i>except Australia, Canada, HK, Mexico</i>)
10	807-3366†	Ignition Module, Dual-Spark Full-Vat (<i>U.S., Canadian, HK, and Mexico units</i>)
11	826-2264	Interface Board Kit SMT
	807-4330	Speaker Adapter Harness SMT
	807-4343	Wire Harness, SMT Interface Board to Ignition Module
12	807-0833	Relay, DPDT 5A 12VDC Latch (See NOTE 1.)
13	810-2243	Spring, Relay Retaining
14	807-4199	Cable, 20-pin Computer to 15-pin Interface Board - SMT
15	806-6085SP	Wire Assembly, Ignitor
*	807-4403	Speaker SMT

* Not illustrated.

NOTE 1: Full-Vat units use one 807-3366 Dual-Spark Ignition Module and one latch relay (Item 12) located in the lower right socket.

2.5.2 Transformer Boxes

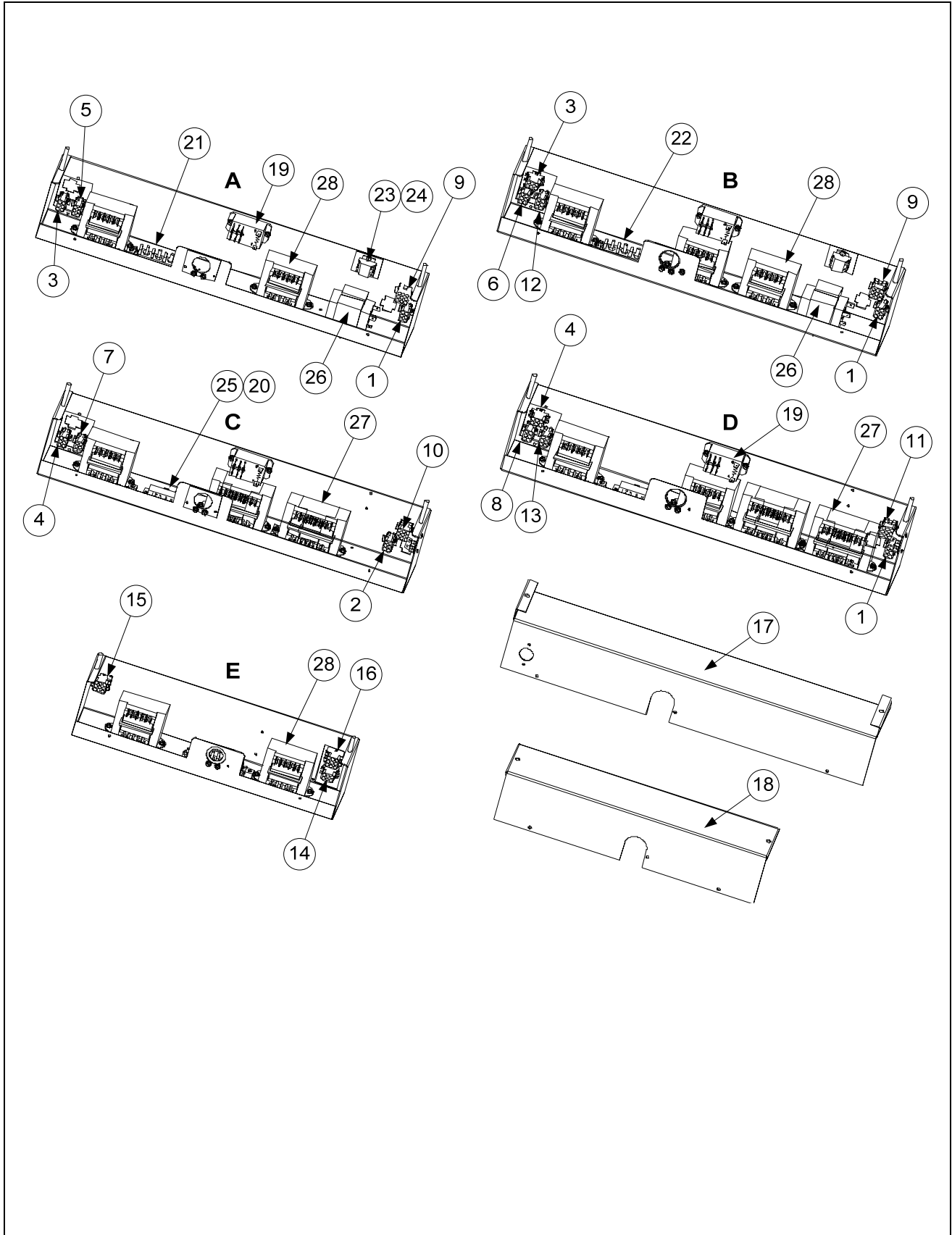

2.5.2 Transformer Boxes cont.

ITEM	PART #	COMPONENT
		Box Assembly, Transformer
A	106-9021SP	FPGL230
B	106-9022	FPGL330
C	106-9734	GL230 CE Export
D	106-9710	GL330 CE Export
E	106-5801	GL430/252
1	106-8133	Cable Assembly, Transformer Box Line GL230,330, 330 CE Export
2	106-8168	Cable Assembly, Transformer Box Line GL230 CE Export
3	106-8170	Cable Assembly, Transformer Box Filter Pump GL230 and 330
4	106-9742	Cable Assembly, Transformer Box Filter Pump GL230 CE Xprt and 330 CE Export
5	106-8162	Cable Assembly, Transformer Box #1 GL230
6	106-3827	Cable Assembly, Transformer Box #1 GL330
7	106-9739	Cable Assembly, Transformer Box #1 GL230 CE Export
8	106-9746	Cable Assembly, Transformer Box #1 GL330 CE Export
9	106-3821	Cable Assembly, Transformer Box #2 GL230 and 330
10	106-9740	Cable Assembly, Transformer Box #2 GL230 CE Export
11	106-9747	Cable Assembly, Transformer Box #2 GL330 CE Export
12	106-3825	Cable Assembly, Transformer Box #3 GL330
13	106-9748	Cable Assembly, Transformer Box #3 GL330 CE Export
14	106-6996	Cable Assembly, Cordset Female
15	806-8706	Plug Assembly, Lt. 252
16	806-8707	Plug Assembly, Rt. 252
17	220-3191	Cover, Transformer Box GL
18	220-0772	Cover, Transformer Box 50/52/55
19	807-4482	Relay, Filter 30A 24VDC DPDT
20	816-0219	Paper, CE Triple Terminal Block Insulating
21	807-0070	Terminal, Ground Lug
22	807-1973	Terminal, Post
23	810-1164	Block, One-Piece Screwless Terminal
24	816-0217	Insulation, Terminal Block Paper
25	810-1163	Block, 3 Places Screwless Terminal
26	807-0800	Transformer, 100-120V/24VAC 50/60Hz 50VA
27	807-1999	Transformer, 208/222/230/240V V/F Dual Voltage
28	807-2176	Transformer, 100-120V V/F Dual Voltage
*	WIR 0798	Wire Assembly, GL330 Transformer/Filter Box (used in Item B)
*	WIR 0799	Wire Assembly, GL230 Transformer/Filter Box (used in Item A)
*	WIR 0852	Wire Assembly, GL230 CE Transformer/Filter Box (used in Item C)
*	WIR 0854	Wire Assembly, GL330 CE Transformer/Filter Box (used in Item D)

* Not illustrated

2.5.3 Computers and Associated Components

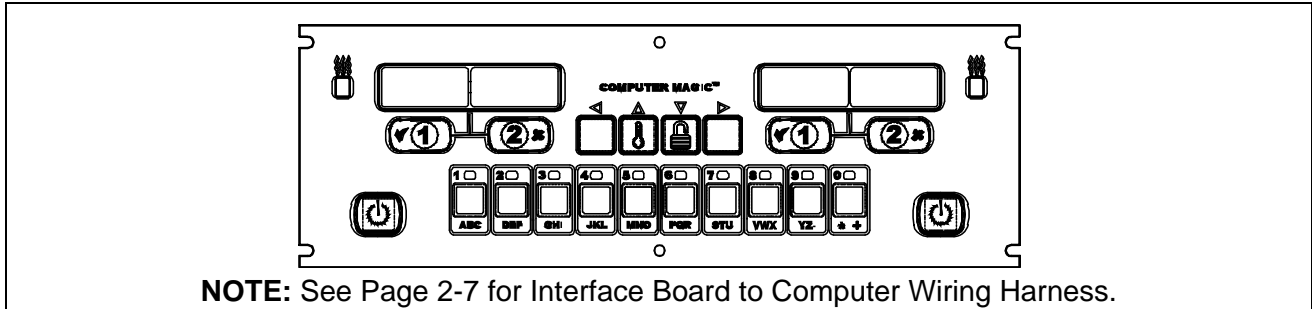

ITEM	PART #	COMPONENT
	108-0231	Replacement CM7 Computer Non-CE CM7 (<i>For use in US, Canada, Mexico and all other non-CE countries</i>)
*	810-3141	Sound Device, Universal SMT

* Not illustrated.

2.6 Wiring

2.6.1 Main Wiring Harnesses

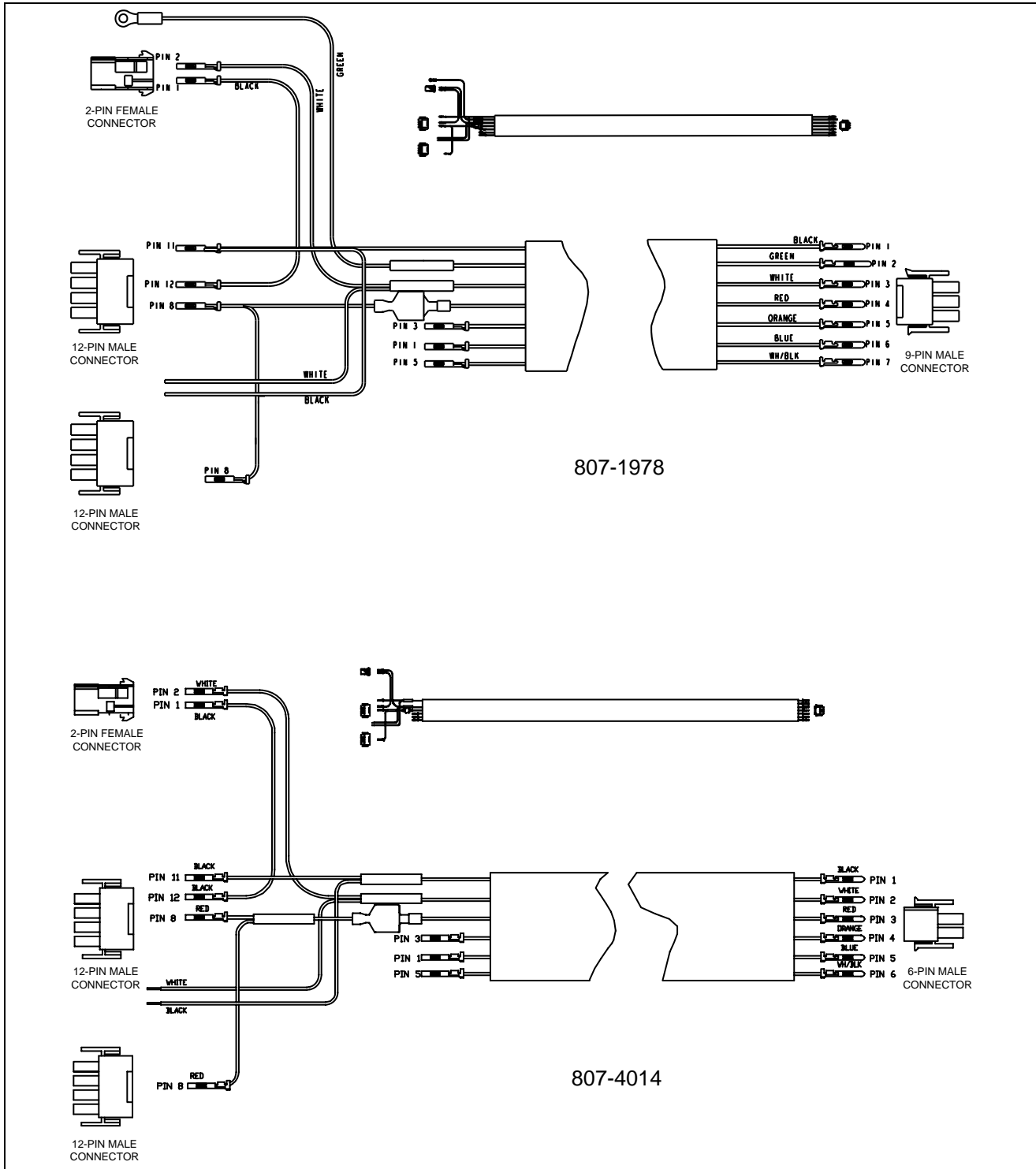

ITEM	PART #	COMPONENT
	807-1978	U.S. and Non-CE Export Main Wiring Harness 50/52
	807-4014	U.S. and Non-CE Export Main Wiring Harness 350/52
	807-2168	CE Main Wiring Harness (not shown)

2.6.2 CM7 and ATO Wiring Harnesses (Refer to wiring diagram on page 1-49.)

ITEM	PART #	COMPONENT
*	807-4546	Computer Communication (used from Computer to Computer)
*	807-4655	FV Harness RTD Medium (used from RTD to ATO Board)
*	807-4654	FV ATO/RTD Probe
*	807-4553	ATO Power (used from Transformer to ATO Board)
*	807-4719	ATO Pump and JIB (used from ATO Board to Top-off Pump and JIB Reset Switch)
*	807-4718	FV ATO Solenoid Harness
*	807-4555	ATO Yellow LED (used from ATO Board to Yellow LED)
*	807-4573	Computer Locator Wire (used from Computer to Interface Board) See wiring diagram 805-1734 for locator pin positions.
*	807-4552	Communications Terminator (used on Computer pin J6 and ATO board pin J10 to terminate network)
	807-4657	Jumper (used on 4 and 5 battery ATO board plug J5 pin 7 and 8)
*	106-9256SP	Long Top-off Power (used between Component Box to ATO Box)
*	807-4660PK	SMT Pin Service Repair Kit
*	230-2345	SMT Pin Extractor

* Not illustrated.

See page 1-31 and 1-37 for Pin Positions.

2.7 Frypots and Associated Components

2.7.1 Full-Vat Frypot Components

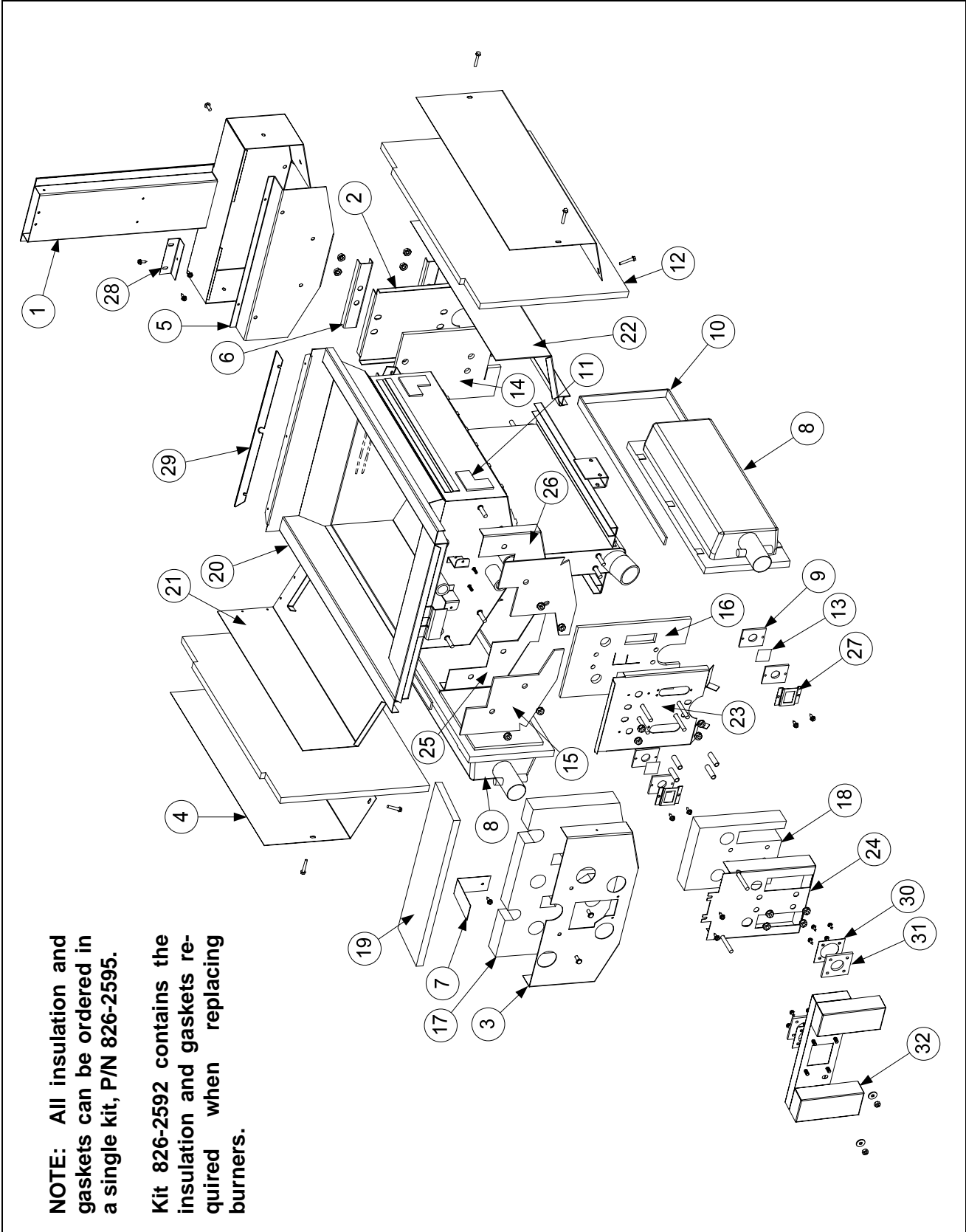

2.7.1 Full-Vat Frypot Components cont.

ITEM	PART #	COMPONENT
	106-8978SP	Frypot Assembly Full-Vat Protector [®] HE (NAT)
	106-8979	Frypot Assembly Full-Vat Protector [®] HE (PRO)
	826-2595	Insulation Kit, Complete Full-Vat
	826-2592	Insulation Kit, Burner Full-Vat
1	106-7524	Flue Assembly, Full-Vat
2	220-2222	Back, Lower Full-Vat Combustion Chamber
3	220-2226	Retainer, Full-Vat Upper Insulation
4	220-2231	Retainer, Outer Frypot
5	222-2694	Plate, FV Collector Mounting
6	220-2851	Brace, FV Rear Insulation
7	220-2920	Brace, Foam Deck Insulation
8	810-3435	Burner, Universal Replacement Protector
9	812-0356	Insulation, Burner Sight Glass
10	812-0357	Insulation, Burner
11	812-0706	Insulation, Upper Burner Rail
12	812-1029	Insulation, Combustion Chamber Side
13	814-0048SP	Glass, Burner Sight
14	816-0730	Insulation, FV Rear Lower
15	816-0731	Insulation, FV LH/RH Front Seal
16	816-0732	Insulation, FV Lower Inner Front
17	816-0733	Insulation, FV Front Upper
18	816-0734	Insulation, FV Outer Front
19	816-0746	Insulation, Foam Deck
20	823-6597	Frypot, FV Protector 439 SS
21	823-6047	Retainer, FV LH Upper Burner
22	823-6048	Retainer, FV RH Upper Burner
23	823-6050	Retainer, FV Front Insulation
24	823-6052	Retainer, FV Outer Front
25	824-1826	LH Upper Seal W/A
26	824-1827	RH Upper Seal W/A
27	900-1031	Retainer, Burner Sight Glass
28	930-0818	Bracket, Flue to Pot
29	900-4253	Strip, Fluecap Retainer
30	900-1049	Retainer, Plenum Gasket
31	816-0057	Gasket, Plenum
*	816-0059	Gasket, Ignitor
32	823-6660	Plenum, Full-Vat LOV (<i>use 823-6940 for CE units</i>)
*	910-2474	Pot-to-Pot Gap Clip

* Not illustrated.

2.7.2 Frypot Assemblies and Associated Parts

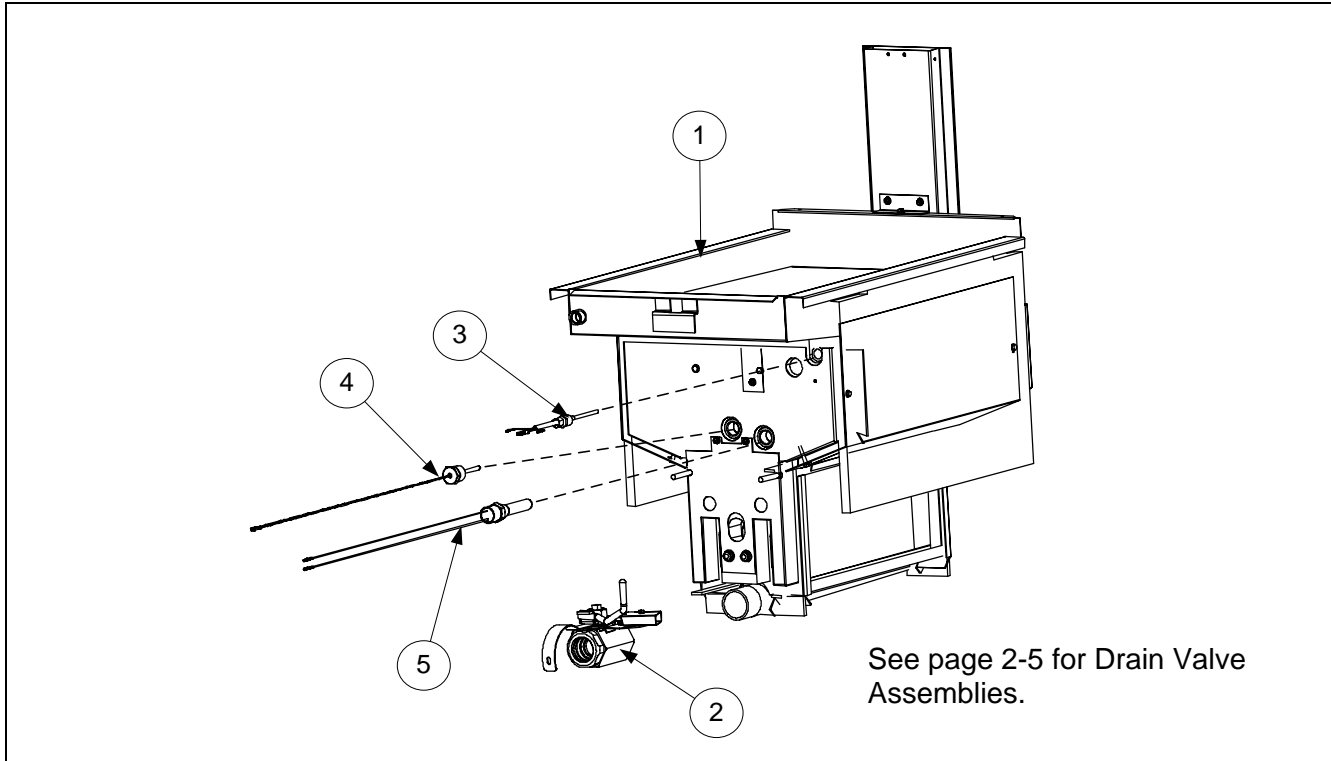

ITEM	PART #	COMPONENT
1	106-8978SP	Frypot Assembly, Full-Vat Protector Natural
	106-8979SP	Frypot Assembly, Full-Vat Protector LP
2	106-9025SP	Valve, Drain Assy. FV
3	826-2569	Probe, RTD and Fitting Kit
4	807-0678	Temperature Probe
*	210-0681	Probe Guard
5	826-1177	Thermostat, High-Limit 425°F/218°C

* Not illustrated.

2.8 Gas Supply and Combustion System Components

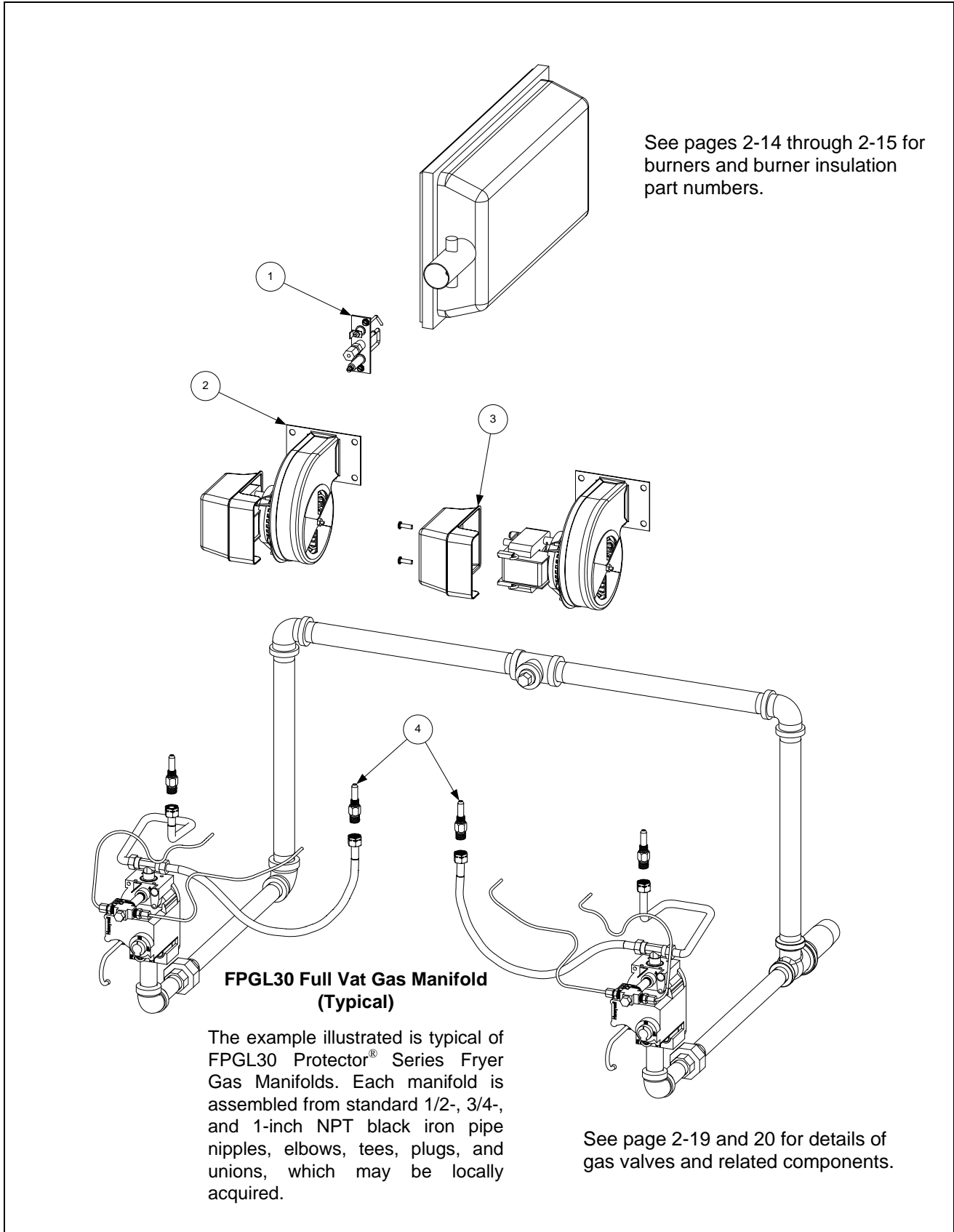

2.8 Gas Supply and Combustion System Components cont.

ITEM	PART #	COMPONENT
1		Ignitor (includes gasket 816-0059, which may be ordered separately)
	826-0981	Natural Gas (G20, G25)
	826-0982	Propane (G30, G31)
	826-1002	Manufactured Gas
2		Blower Assembly, Combustion Air (includes harness and Items 4, and 5)
	106-2996SP	100V 50/60 Hz (Left)
	106-2999SP	100V 50/60 Hz (Right)
	106-2994SP	115V 50/60 Hz. (Left)
	106-2997SP	115V 50/60 Hz (Right)
	106-2995SP	208-240V 50/60 Hz (Left)
	106-2998SP	208-240V 50/60 Hz (Right)
	106-3000SP	230V 50/60 Hz CE (Left)
	106-3001SP	230V 50/60 Hz CE (Right)
3	816-0554	Cover, Blower Motor (component of all blowers listed above)
*	806-8806SP	Harness Assembly, Blower Motor (component of all blowers listed above)
4		Orifice, Burner
	812-1137	1.95 mm Propane/Butane (G30, G31) (0-4999 Ft, 0-1524 M) (CE)
	810-1221	2.00 mm Propane/Butane (0-4999 Ft, 0-1524 M) (Japan only)
	810-0386	2.10 mm Propane/Butane (0-4999 Ft, 0-1524 M)
	810-0413	2.16 mm Propane/Butane (G30, G31) (5000-6999 Ft, 1525-2133 M)
	812-1028	2.20 mm Propane/Butane (G30, G31) (7000-10,999 Ft, 2134-3352 M)
	812-1134	3.10 mm Natural Gas (G20, G25) (0-4999 Ft, 0-1524 M) (Japan only)
	810-0403	3.40 mm Natural Gas (G20, G25) (0-4999 Ft, 0-1524 M)
	810-0437	3.60 mm Natural Gas (G20, G25) (5000-6999 Ft, 1525-2133 M)
	812-1144	3.65 mm Natural Gas (G20, G25) (7000-8999 Ft, 2134-2743 M)
	812-1145	3.70 mm Natural Gas (G20, G25) (9000-10,999 Ft, 2744-3352 M)
	810-0642	5.95 mm Manufactured Gas (0-4999 Ft, 0-1524 M)
*	826-1196	Conversion Kit, Natural Gas (G20, G25) to Propane/Butane (G30, G31) CE only
*	826-1197	Conversion Kit, Propane/Butane (G30, G31) to Natural Gas (G20, G25) CE only
*	807-2263	Switch, Air Pressure (<i>use 807-2262 in units with 100VAC power supply</i>)

* Not illustrated.

2.9 Gas Valves and Associated Components

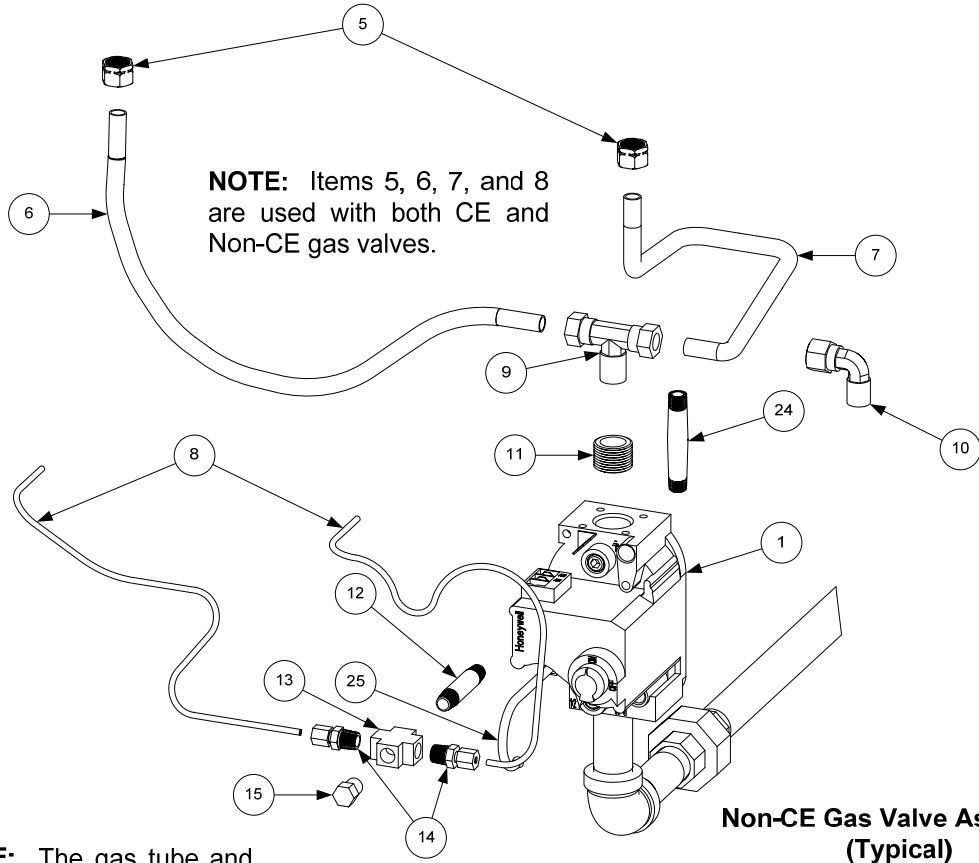

NOTE: The gas tube and enrichment tube fittings are assembled in varying configurations depending upon the location of the valve and whether the associated frypot is a full- or dual-vat pot.

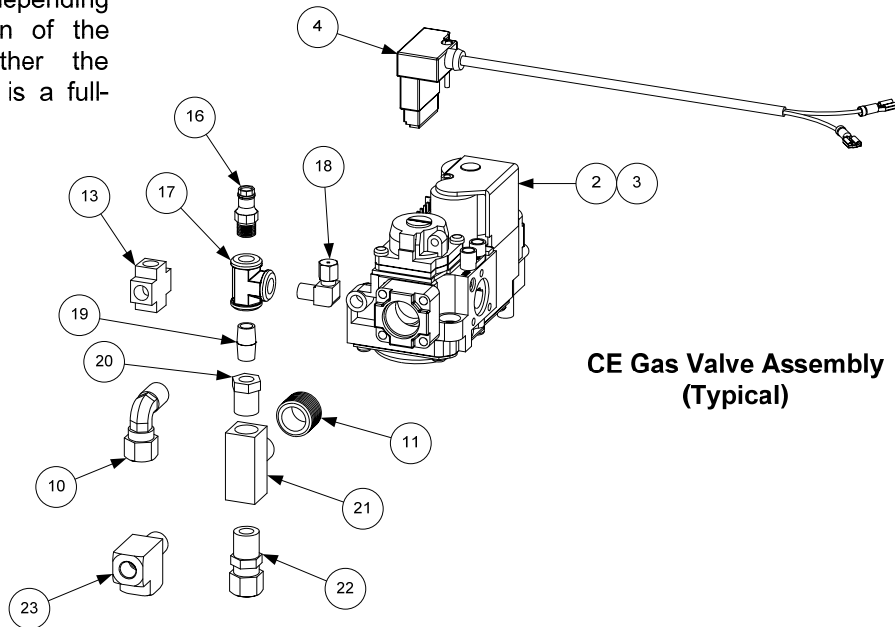

2.9 Gas Valves and Associated Components cont.

ITEM	PART #	COMPONENT
1		Valve, Non-CE Gas
	826-1122	Natural Gas (G20, G25)
	826-1120	Kit Natural Gas w/ flexlines and hardware
	826-1123	Propane Gas (G30, G31)
	826-1121	Kit, Propane Gas w/ flexlines and hardware
2	810-1715	Valve, CE Gas (G20, G25, G30, G31)
3	810-1041	Accessory Kit (contains parts to adapt Item 2 to specific fryer configuration)
4	806-9678SP	Plug Assembly, CE Gas Valve
5	810-0494	Ferrule (Nut), Orifice
6	810-1355	Gas Line, 3/8-inch OD X 15-inch SS Flexible
7	810-1354	Gas Line, 3/8-inch OD X 12-inch SS Flexible
	810-1353	Gas Line, 3/8-inch OD X 9-inch SS Flexible (Used on some split pots)
8	811-0800	Tube, 1/8-inch OD X 12.5-inch Enrichment (cut and form to fit)
9	813-0301	Tee, 1/4-inch Male NPT to 3/8-inch Tube
10	813-0302	Elbow, 1/4-inch Male NPT to 3/8-inch Tube 90° (used on DV valve)
11	813-0304	Bushing, 1/2-inch NPT to 1/4-inch NPT Flush Reducing
12	813-0405	Nipple, 1/8-inch NPT X 2-inch
13	813-0378	Fitting, 1/8-inch NPT Cross
14	813-0340	Adapter, 1/8-inch NPT to 1/8-inch Tube
15	813-0154	Plug, 1/8-inch NPT Hex Head Pipe
16	810-1176	Tap, 1/8-inch NPT Pressure
17	813-0377	Tee, 1/8-inch NPT Female
18	813-0354	Elbow, 1/8-inch NPT X 1/8-inch Tube Compression
19	813-0016	Nipple, 1/8-inch NPT X Close
20	810-1006	Bushing, 1/4-inch NPT to 1/8-inch NPT Reducing
21	813-0495	Tee, 1/4-inch Male NPT to Female NPT
22	810-1025	Connector, 1/4-inch Male NPT to 3/8-inch Tube
23	810-1026	Tee, 1/4-inch Male NPT to Female NPT Street
24	813-0700	Nipple, 1/4-inch NPT x 3-inch
25	810-0691	Tube, 1/8-inch Vent

2.10 Filtration System Components

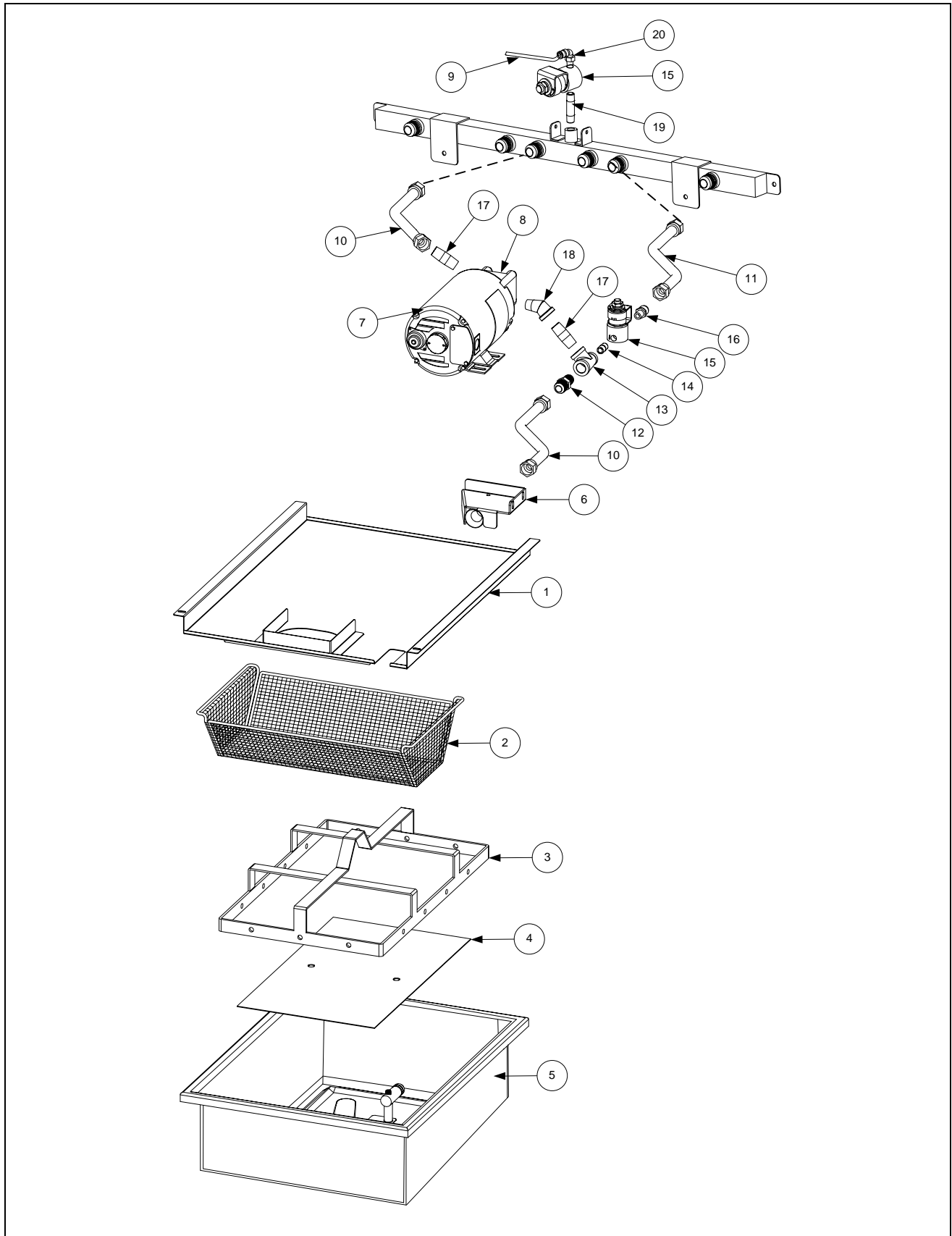

2.10 Filtration System Components cont.

ITEM	PART #	COMPONENT
1	823-6616	Lid, Multi-Vat Fryers, Standard Size Filter Pan
	823-6333	Lid, Two-Vat Fryer, Half Size Filter Pan
2	810-2874	Crumb Tray, Standard Size Filter Pan 3, 4 and 5 Vat
	810-3288	Crumb Tray, Two-Vat Fryer, Half Size Filter Pan
3	810-2091	Hold-Down Ring 13.65 x 21.41, Standard Size Pan 3, 4, and 5 Vat
	810-3289	Hold-Down Ring 11.20 x 19.10, Two-Vat Fryer, Half Size Filter Pan
4	812-2024	SanaGrid Filter Screen, Standard Size Filter Pan
	812-2041	SanaGrid Filter Screen, Two-Vat Fryer, Half Size Filter Pan
5	106-8677	Pan, One-Piece Filter Standard Size
	106-8211SP	Pan, Two-Vat Fryer, Half Size
*	826-1392	O-Ring (Pkg. of 5; used with Item 5)
*	813-0568	Plug, 1/8-inch Socket Head Pipe (used with Item 5; two required)
6	823-3879	Suction Tube Standard
	823-6458	Suction Tube Two Vat
7		Motor and Gasket Kit
	826-1785	100V 50/60 Hz
	826-1712	115V 50/60 Hz
	826-1756	208V 50/60 Hz
	826-1270	220-240V 50/60 Hz
	826-1755	250V 50/60 Hz
8	826-1264	Pump and Gasket Kit, 4 GPM
	816-0093	Gasket, Pump/Motor
*	807-11973	Viking Pump Seal Kit
*	809-1020	Cap Screw, 5/16-inch-18 5.50" NC Hex (<i>Connects pump to motor.</i>)
9	811-1071	Tube, 1/4-inch OD Teflon Manifold Vent
10	810-1055	Flexline, 11.5-inch Oil Return
11	810-1680	Flexline, 6.5-inch Oil Return
12	810-1668	Adapter, 5/8-inch to 1/2-inch NPT Male
13	813-0530	Tee, 1/2-inch x 1/2-inch x 1/4-inch Reducing
14	813-0838	Nipple, 1/4-inch NPT Close
15	106-3470	Valve, 1/4-inch NPT Solenoid
16	810-2773	Adaptor, 1/4-inch NPT to 1/2-inch NPT
17	813-0298	Nipple, 1/2-inch NPT x 2.00-inch
18	813-0342	Elbow, Street 45° x 1/2-inch NPT
19	813-0700	Nipple, 1/4-inch NPT x 3.00-inch
20	810-2493	Elbow, 90° 1/8-inch NPT x 1/4-inch Quick Connect
*	106-5911	Heater Strip Assembly, 100-120V 25W 18"
*	106-5912	Heater Strip Assembly, 208-250V 25W 18"

* Not illustrated.

2.11 Return Valve Assembly and Associated Parts

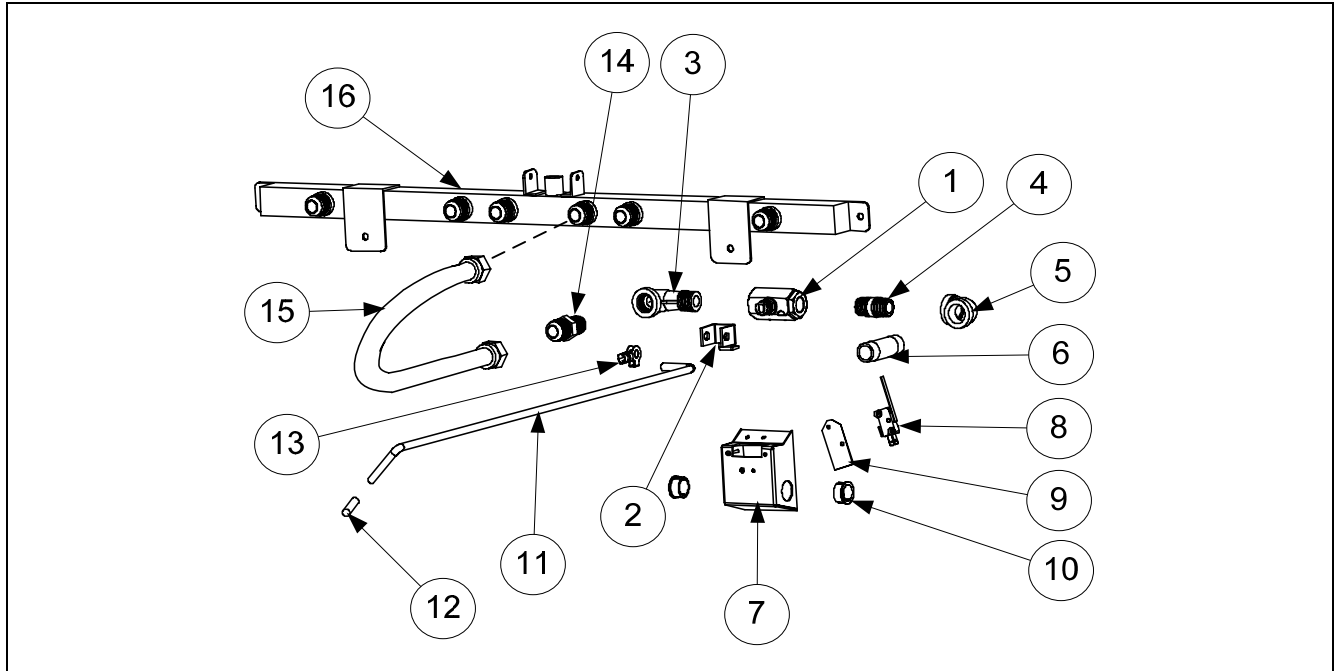

ITEM	PART #	COMPONENT
	106-8018	Valve, Return Assy. FV
1	810-2201	Valve, Return 1/2" Ball
2	902-2772	Handle, Right Valve
3	813-0165	Elbow, Street 1/2" x 1/2" NPT 90° BM
4	813-0087	Nipple, 1/2" x 1.50" NPT
5	813-0062	Elbow, 90° 1/2" BM
6	813-0265	Nipple, 1/2" x 2.50 NPT BM
7	824-1601	Cover, Microswitch RR Flush
8	807-4101	Switch, Micro
9	816-0220	Insulation, RF Switch
10	810-0045	Bushing, .875 Diameter Hole 11/16
11	212-6701	Rod, Handle Right RF
12	816-0643	Grip, Oil Return Valve Handle
13	809-0601	Clip, Clevis
14	810-1668	Adaptor, Male 5/8" OD x 1/2"
15	810-1067	Flexline, 5/8" OD x 8.50" Long
16		Manifold, Rear Oil Return
	810-3275	Two-Station Fryer
	810-3245	Three-Station Fryer
	810-3368	Four-Station Fryer

2.12 ATO (Auto Top-Off) Components

2.12.1 JIB (Jug In Box) Low Indicator Light Assembly

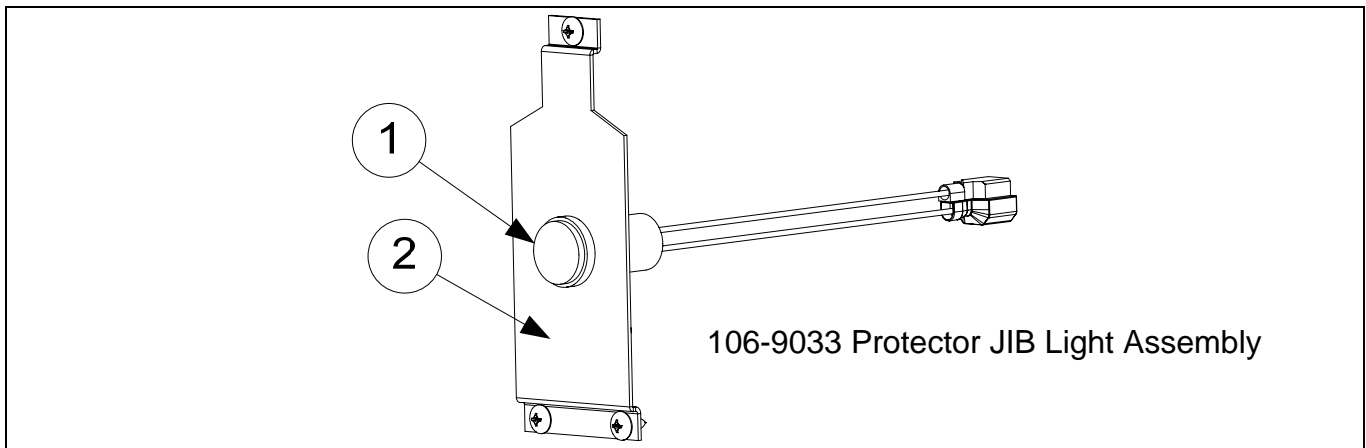

ITEM	PART #	COMPONENT
1	106-8105SP	Light, Yellow 24VDC LED Flush
2	230-4142	Bracket, Protector Light

2.12.2 ATO (Automatic Top-Off) Board

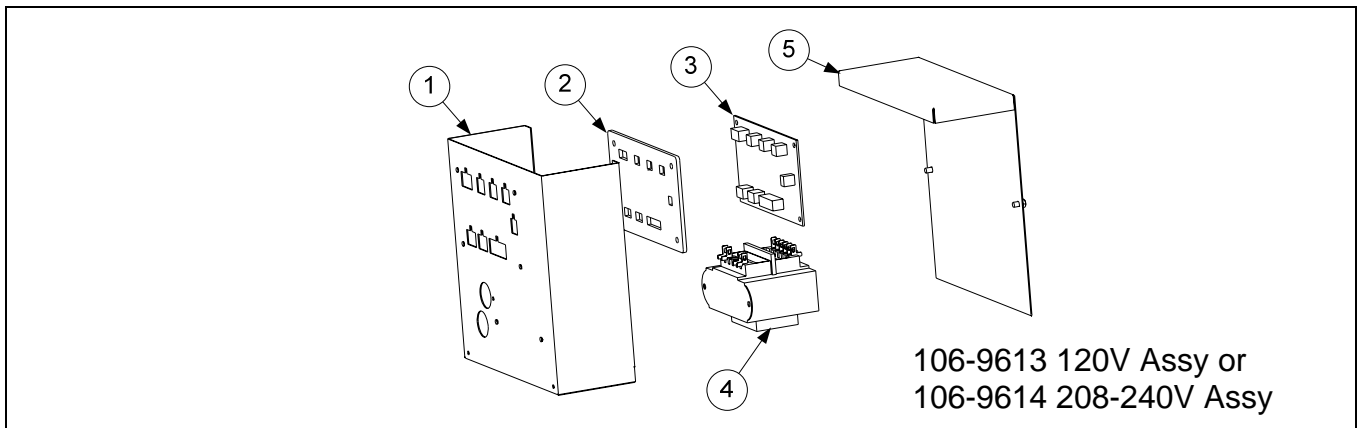

ITEM	PART #	COMPONENT
1	106-9258	Box, Assembly Auto Top Off 2 Board RTD
2	816-0771	Seal, Top Off Board
3	106-9611	PCB Board, Automatic Top Off 2 RTD
4	807-1999	Transformer, Dual Voltage 208-240V
	807-2176	Transformer, Dual Voltage 120V
5	220-4352	Cover, Top Off Board 3, 4 or 5-Vat
	220-3987	Cover, Top Off Board 2-Vat
*	807-3575	Plug, Carling Switch Hole

* Not illustrated.

2.12.3 ATO (Automatic Top-Off) Solenoid and Pump Assemblies

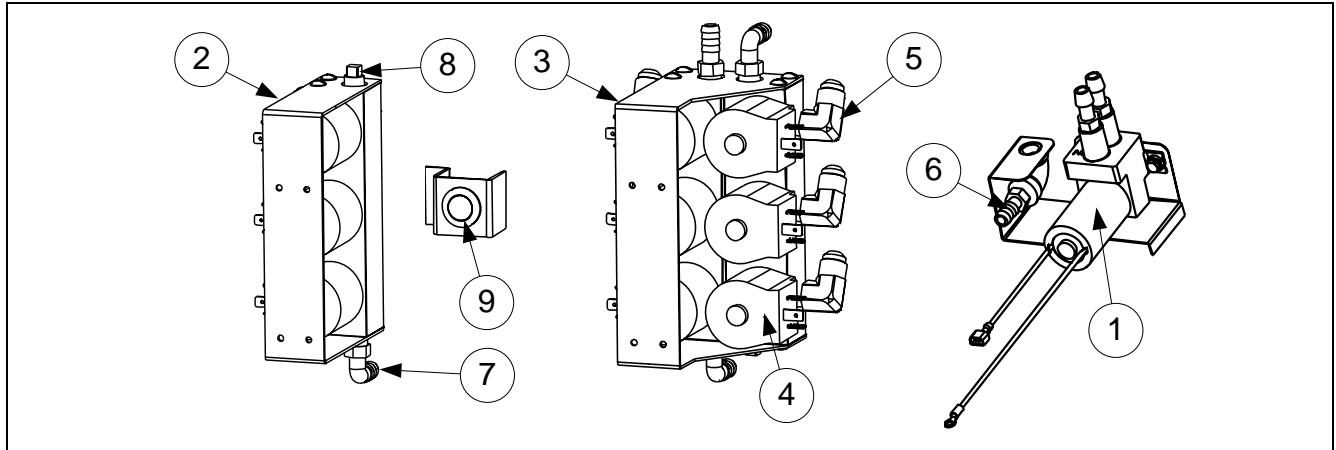

ITEM	PART #	COMPONENT
1	106-9680SP	Pump, ¼ FNPT 12VDC, 19PSI 15.1GPH
2	106-8477	Solenoid Manifold Assembly GL30-3 (includes three solenoid assemblies)
3	106-8014	Solenoid Manifold Assembly GL30-6 (includes six solenoid assemblies)
4	807-4590	Solenoid
5	813-0940	Elbow, ¼ NPT x ⅜ Flare
6	816-0708	Fitting, ¼ NPT x ½ Male Barb
7	816-0710	Fitting, ¼ NPT x ½ Barb 90°
8	813-0640	Plug, ¼ NPT SQ HD BM
9	807-4493	Switch, Momentary Flush
*	811-1139	Tubing, Braided Silicone 20-inch
*	810-3375	Flexline, ½" OD x 17-inch (used between solenoid and top off port)
*	810-3265	Flexline, ½" OD x 24-inch (used between solenoid and top off port)
*	810-3263	Flexline, ½" OD x 36-inch (used between solenoid and top off port)

* Not illustrated.

2.12.4 JIB Cradle, JIB/BIB Cap and Pick Up Assemblies

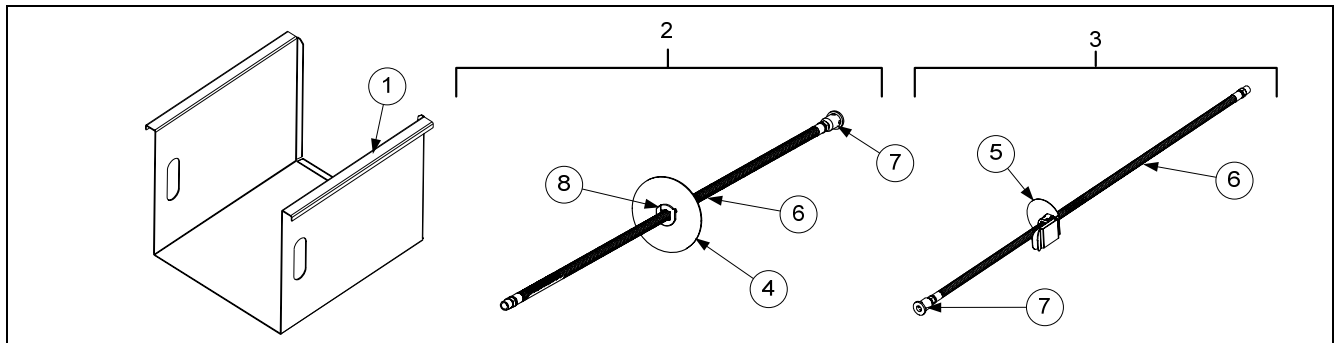

ITEM	PART #	COMPONENT
1	220-3647	Cradle, JIB Gas LOV
2	106-8512SP	Cap, JIB Assembly
3	106-9495	Cap, BIB Assembly (used internationally)
4	230-3737	Cap, JIB
5	823-6812	Cap w/ Clamp, BIB Assembly (used internationally)
6	810-3242	Hose, JIB
7	810-3300	Inlet, Oil Reservoir Tube
8	810-3334	Bushing, Heyco

2.13 Wiring Connectors, Pin Terminals and Tools

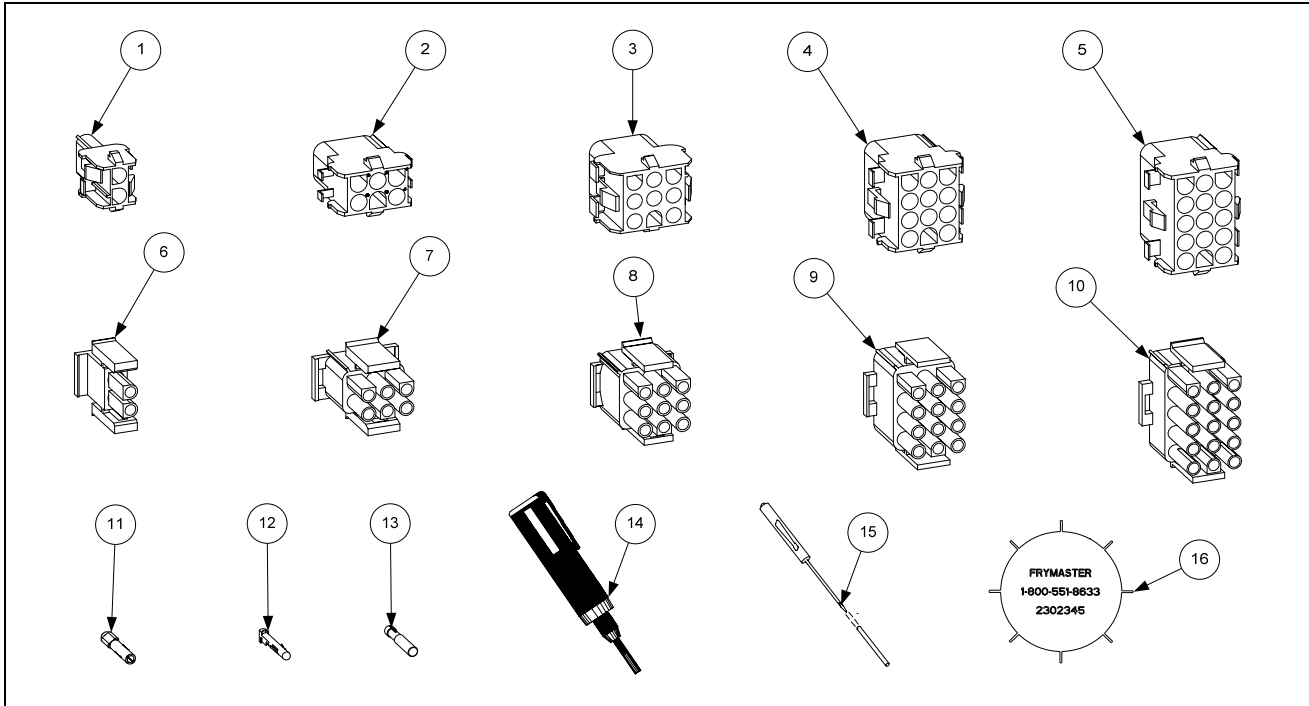

ITEM	PART #	COMPONENT
1	807-1068	2-Pin Female
2	807-0158	6-Pin Female
3	807-0156	9-Pin Female
5	807-0159	12-Pin Female
5	807-0875	15-Pin Female
6	807-1067	2-Pin Male
7	807-0157	6-Pin Male
8	807-0155	9-Pin Male
9	807-0160	12-Pin Male
10	807-0804	15-Pin Male
11	826-1341	Terminal, Female Split Pin (Pkg of 25)
12	826-1342	Terminal, Male Split Pin (Pkg of 25)
13	807-2518	Plug, Mate-N-Lock (Dummy Pin)
14	807-0928	Extract Tool Pin Pusher
15	806-4855	Pin Pusher Screwdriver Assembly
16	230-2345	SMT Pin Extractor

* Not illustrated.

2.14 Fasteners

ITEM	PART #	COMPONENT
*	809-0429	Bolt, 1/4-inch – 20 x 2.00-inch Hex Head ZP Tap
*	809-0131	Bolt, 1/4-inch -20 x 3/4-inch Hex
*	809-0953	Bolt, 1/4-20 x 3/4-inch Hex Head
*	807-1926	Bushing, .875-inch Split
*	809-0514	Capscrew, 5/16-inch-18 NC Hex
*	809-0448	Clip, Tinnerman
*	826-1351	Nut Retainer, 1/4-20 (Pkg. of 10 – for basket hanger thumbscrew) Std. Fluecap
*	809-0171	Thumbscrew, 1/4-20 x 1 3/8-inch (for use on Standard Fluecap)
*	826-1366	Nut, 4-40 Keps Hex (Pkg. of 25) (809-0237)
*	826-1358	Nut, 6-32 Keps Hex (Pkg. of 25) (809-0049)
*	809-0247	Nut, 8-32 Keps Hex
*	809-0052	Nut, 10-24 Hex
*	826-1376	Nut, 10-32 Keps Hex (Pkg. of 10) (809-0256)
*	809-0766	Nut, 10-32 Keps Hex SS
*	809-0581	Nut, 1/2 NPT Locking
*	809-0020	Nut Cap 10-24 NP
*	826-1372	Nut Grip 1/4-inch 1/4-20 Hex NP (Pkg. of 10) (809-0059)
*	809-0417	Nut Flange 1/4-inch 1/4-20 Serr
*	809-0535	Nut, "T" 1/4-inch-20 x 7/16 SS
*	809-0495	Nut, 1/4-inch - 20 Press
*	809-0804	Nut, 1/4- inch - 20 Keps Hex
*	826-1362	Nut, 1/4-20 Hex (Pkg. of 10) (809-0071)
*	809-0540	Nut, Lock 1/2-inch-13 Hex 2-Way ZP
*	809-0656	Screw, 4-40 X 3/8-inch Slotted Round Head
*	826-1359	Screw, 4-40 x 3/4-inch Slotted Round Head (Pkg. of 25) (809-0354)
*	826-1365	Screw, 6-32 x 3/8-inch Slot Head (Pkg. of 25) (809-0095)
*	809-0098	Screw, 6-32 x 1 1/4-inch Slotted Round Head
*	809-0357	Screw, 6 x 3/8-inch Phillips Head NP
*	809-0359	Screw, 8 x 1/4-inch Hex Washer Head
*	809-0360	Screw, 8 x 3/8-inch Hex Washer Slot Head
*	826-1371	Screw, 8 x 1/2-inch Hex Head ZP (Pkg. of 25) (809-0361)
*	809-0364	Screw, 8 x 5/8-inch Hex Washer Head ZP
*	809-0441	Screw, 8 x 1 1/2-inch Hex Washer Head
*	809-0362	Screw, 8 x 1 1/4-inch Hex Washer Head Drill Point
*	809-0518	Screw, 8-32 x 3/8-inch Hex Washer Slotted Head SS
*	809-0104	Screw, 8-32 x 1/2-inch Slotted Head ZP
*	826-1363	Screw, 8-32 x 1/2-inch NP (Pkg. of 25) (809-0103)
*	826-1360	Screw, 10-24 x 5/16-inch Round Slot Head ZP (Pkg. of 25) (809-0024)
*	809-0123	Screw, 10-24 x 3/4-inch Slotted Truss Head
*	826-1330	Screw, 10-32 x 3/8-inch Slot Head SS (Pkg. of 25) (809-0117)
*	809-1003	Screw, 10-32 x 3/8-inch Hex Trim Head SS
*	809-0938	Screw, 10-32 x 5/8-inch Philips Truss Head
*	826-1375	Screw, 10-32 x 3/4-inch Hex Trim Head SS (Pkg. of 5) (809-0401)
*	809-1000	Screw, 10-32 x 1 1/4-inch Hex Sck C/S
*	826-1374	Screw, 10 x 1/2-inch Hex Head (Pkg. of 25) (809-0412)
*	809-0266	Screw, 10 x 1/2-inch Phillips Head ZP

continued on the following page

2.14 Fasteners cont.

ITEM	PART #	COMPONENT
*	809-0500	Screw, 10 x ½-inch Hex Washer Head 410 SS
*	809-0434	Screw, 10 x ⅜-inch Hex Washer Head NP
*	809-0123	Screw, 10 x ¾-inch Slot Head
*	826-1389	Screw, ¼-20 x ¾-inch Hex Head ZP (Pkg. of 10) (809-0131)
*	826-1346	Spacer, Ignition Module (Pkg. of 10)
*	810-2763	Spacer, Interface Board
*	826-1340	Spacer, .25-inch x 1.187-inch (Pkg. of 10)
*	810-0500	Spacer, .25-inch x .9375-inch
*	810-2023	Spacer, .25-inch x .110-inch (Used on drain valves.)
*	200-6721	Plate, Strain Relief
*	826-1337	Tab, ¼-inch Terminal (Pkg. of 5)
*	807-0070	Terminal, Ground Lug
*	807-1948	Ty-Wrap
*	807-1359	Mount, Ty-Wrap
*	826-1383	Washer, ¾-inch O.D. x ¼-inch I.D. ZP (Pkg. of 5) (809-0435)
*	809-0582	Washer ½ NPT Locking
*	809-0184	Washer, #10 LK ZP
*	809-0190	Washer, .625 X .275 X 40 Flat SS
*	809-0191	Washer, Lock ¼ Spring ZP
*	809-0193	Washer, Flat ¼ Nylon
*	809-0194	Washer, Flat 5/16 ZP
*	809-0196	Washer, ⅜-inch Flat
*	810-1165	Washer, ⅜-inch Teflon

THIS PAGE INTENTIONALLY LEFT BLANK



Frymaster, L.L.C., 8700 Line Avenue, Shreveport, Louisiana 71106

TEL 1-318-865-1711 FAX (Parts) 1-318-219-7140 FAX (Tech Support) 1-318-219-7135

PRINTED IN THE UNITED STATES

SERVICE HOTLINE
1-800-551-8633

819-6345
FEBRUARY 2009

Free Manuals Download Website

<http://myh66.com>

<http://usermanuals.us>

<http://www.somanuals.com>

<http://www.4manuals.cc>

<http://www.manual-lib.com>

<http://www.404manual.com>

<http://www.luxmanual.com>

<http://aubethermostatmanual.com>

Golf course search by state

<http://golfingnear.com>

Email search by domain

<http://emailbydomain.com>

Auto manuals search

<http://auto.somanuals.com>

TV manuals search

<http://tv.somanuals.com>