



**Super Runner and Super Marathon Series**

# Dean Millivolt Gas Fryers Service & Parts Manual



NON-CE &



Dean, a member of the Commercial Food Equipment Service Association, recommends using CFESA Certified Technicians.

**24-Hour Service Hotline**

**1-800-551-8633**

Email: [service@frymaster.com](mailto:service@frymaster.com)

[www.frymaster.com](http://www.frymaster.com)

MAY 2008

\* 8195948 \*

**Please read all sections of this manual and retain for future reference.**

**NOTICE**

This appliance is intended for professional use only and is to be operated by qualified personnel only. A Dean Factory Authorized Service Center (FASC) or other qualified professional should perform installation, maintenance, and repairs. Installation, maintenance, or repairs by unqualified personnel may void the manufacturer's warranty.

**NOTICE**

This equipment must be installed in accordance with the appropriate national and local codes of the country and/or region in which the appliance is installed.

**NOTICE**

Drawings and photos used in this manual are intended to illustrate operational, cleaning and technical procedures and may not conform to onsite management operational procedures.

**NOTICE**

IF, DURING THE WARRANTY PERIOD, THE CUSTOMER USES A PART FOR THIS ENODIS EQUIPMENT OTHER THAN AN UNMODIFIED NEW OR RECYCLED PART PURCHASED DIRECTLY FROM FRYMASTER DEAN, OR ANY OF ITS AUTHORIZED SERVICE CENTERS, AND/OR THE PART BEING USED IS MODIFIED FROM ITS ORIGINAL CONFIGURATION, THIS WARRANTY WILL BE VOID. FURTHER, FRYMASTER DEAN AND ITS AFFILIATES WILL NOT BE LIABLE FOR ANY CLAIMS, DAMAGES OR EXPENSES INCURRED BY THE CUSTOMER WHICH ARISE DIRECTLY OR INDIRECTLY, IN WHOLE OR IN PART, DUE TO THE INSTALLATION OF ANY MODIFIED PART AND/OR PART RECEIVED FROM AN UNAUTHORIZED SERVICE CENTER.

** DANGER**

Improper installation, adjustment, maintenance or service, and unauthorized alterations or modifications can cause property damage, injury, or death. Read the installation, operating and service instructions thoroughly before installing or servicing this equipment. Only qualified service personnel may convert this appliance to use a gas other than that for which it was originally configured.

** DANGER**

Adequate means must be provided to limit the movement of this appliance without depending upon the gas line connection. Single fryers equipped with legs must be stabilized by installing anchor straps. All fryers equipped with casters must be stabilized by installing restraining chains. If a flexible gas line is used, an additional restraining cable must be connected at all times when the fryer is in use.

**⚠ DANGER**

The front ledge of the fryer is not a step. Do not stand on the fryer. Serious injury can result from slips or contact with the hot oil.

**⚠ DANGER**

Do not store or use gasoline or other flammable vapors and liquids in the vicinity of this or any other cooking appliance.

**⚠ DANGER**

Instructions explaining procedures to be followed **MUST** be posted in a prominent location in the event the operator detects a gas leak. This information can be obtained from the local gas company or gas supplier.

**⚠ DANGER**

The crumb tray in fryers equipped with a filter system must be emptied into a fireproof container at the end of frying operations each day. Some food particles can spontaneously combust if left soaking in certain shortening material. Additional information can be obtained in the filtration manual included with the system.

**⚠ WARNING**

No structural material on the fryer should be altered or removed to accommodate placement of the fryer under a hood. Questions? Call the Dean Service Hotline at 1-800-551-8633.

**⚠ WARNING**

Do not bang fry baskets or other utensils on the fryer's joiner strip. The strip is present to seal the joint between the frypot. Banging fry baskets on the strip to dislodge shortening will distort the strip, adversely affecting its fit. It is designed for a tight fit and should only be removed for cleaning.

**IMPORTANT**

Safe and satisfactory operation of Dean equipment depends upon its proper installation. Installation **MUST** conform with local codes, or in the absence of local codes, to European Community (CE) Standards.



**Dean Millivolt Gas Fryers  
Service and Parts Manual**

**TABLE OF CONTENTS**

	<b>Page #</b>
<b>1. SERVICE PROCEDURES</b> .....	<b>1-1</b>
<b>1.1 Functional Description</b> .....	<b>1-1</b>
<b>1.2 Accessing Fryers for Servicing</b> .....	<b>1-3</b>
<b>1.3 Cleaning the Gas Valve Vent Tube</b> .....	<b>1-3</b>
<b>1.4 Calibrating the Operating Thermostat</b> .....	<b>1-4</b>
<b>1.5 Check Burner Manifold Pressure</b> .....	<b>1-5</b>
<b>1.6 Adjusting the Pilot Flame</b> .....	<b>1-6</b>
<b>1.7 Replacing Fryer Components</b> .....	<b>1-6</b>
1.7.1 Replacing the Operating Thermostat.....	<b>1-6</b>
1.7.2 Replacing the High-Limit Thermostat.....	<b>1-8</b>
1.7.3 Replacing the Gas Valve.....	<b>1-8</b>
1.7.4 Replacing the Frypot.....	<b>1-8</b>
<b>1.8 Troubleshooting and Problem Isolation</b> .....	<b>1-9</b>
1.8.1 Pilot Failures.....	<b>1-9</b>
1.8.2 Improper Burner Functioning.....	<b>1-12</b>
1.8.3 Improper Temperature Control.....	<b>1-12</b>
1.8.4 Filtration Problems.....	<b>1-13</b>
1.8.5 Leaking.....	<b>1-14</b>
<b>1.9 Wiring Diagrams</b> .....	<b>1-15</b>
1.9.1 Current Production Units with Honeywell Gas Valve (Non-CE).....	<b>1-15</b>
1.9.2 Current Production Units with Honeywell Gas Valve (CE).....	<b>1-16</b>
1.9.3 Current Production Units with Robertshaw Gas Valve (After May, 2002).....	<b>1-17</b>
1.9.4 UFF Filtration Wiring Diagram.....	<b>1-18</b>



**Dean Millivolt Gas Fryers  
Service and Parts Manual**

**TABLE OF CONTENTS (CONT.)**

	<b>Page #</b>
<b>2. PARTS LIST</b> .....	<b>2-1</b>
<b>2.1 Cabinetry Components, Single Fryers</b> .....	<b>2-1</b>
<b>2.2 Cabinetry Components, Multi-Battery Systems</b> .....	<b>2-4</b>
<b>2.3 Component Box Components and Related Components (Non-CE and CE)</b> ...	<b>2-6</b>
<b>2.4 Frypot and Burner System Components</b> .....	<b>2-8</b>
<b>2.4.1 SM220 and SM20/20/~ Systems</b> .....	<b>2-8</b>
<b>2.4.2 SR Series, SM35G, SM40G and SM50G Systems</b> .....	<b>2-10</b>
<b>2.4.3 SM60G and SM80G Systems</b> .....	<b>2-13</b>
<b>2.5 Oil Drain Manifold, Drain Flush and Drain Valve Components</b> .....	<b>2-16</b>
<b>2.6 Oil Return Manifold Components</b> .....	<b>2-20</b>
<b>2.7 Oil Return and Oil Flush Components</b> .....	<b>2-23</b>
<b>2.8 Under Fryer Filter (UFF) Components</b> .....	<b>2-27</b>
<b>2.8.1 SM50 and SM60 Series Fryers (Except IHOP)</b> .....	<b>2-27</b>
<b>2.8.2 SM50 Series Fryers, IHOP UFF 50 with Filter Leaf</b> .....	<b>2-28</b>
<b>2.8.3 SM80 Series Fryers</b> .....	<b>2-29</b>
<b>2.9 Single Under Fryer Filter (SUFF) Components</b> .....	<b>2-30</b>
<b>2.9.1 SM50 Series Fryers</b> .....	<b>2-30</b>
<b>2.9.2 SM60 and SM80 Series Fryers</b> .....	<b>2-31</b>

# DEAN MILLIVOLT GAS FRYERS

## CHAPTER 1: SERVICE PROCEDURES

### 1.1 Functional Description

Dean Super Runner and Super Marathon Series fryers are millivolt fryers, which require no electricity to operate (systems with built-in filtration and/or other accessories will require electric power). Dean millivolt fryers contain a welded steel frypot (stainless or cold-rolled) that is heated by gas flames diffused evenly through tubes built into the frypot. The number of tubes varies from three to five, according to the fryer model and size.

Flames originate from orifices in a burner manifold positioned beneath cast-iron burners. The burners are positioned in the tube openings, at the front of the frypot. Diffusers within each tube distribute the flame evenly throughout the tube. The diameter of the orifices differs for natural (CE:G20/G25) and LP (CE:G31) gas as indicated in the accompanying table.

<b>NON-CE (Altitudes of 2000 feet or less)</b>							
MODEL	INPUT (BTU)	GAS TYPE	ORIFICE MM (INCH)	ORIFICE PART NO.	QTY	EQUIPMENT PRESSURE	
						MBAR	INCH W.C.
SM20GM	50	NAT LP	2.18(#44) 1.40(#54)	810-2050 810-2324	2	10	4
					2	27.5	11
SM 35 (40) GM SR 42GM	105	NAT LP	2.80(#35) 1.70(#51)	810-2040/*810-3097 810-2064/*810-3099	3	10	4
					3	27.5	11
SR 52 GM SM 50 GM	120	NAT LP	2.53(#39) 1.51(#53)	810-2048 810-2059	4	10	4
					4	27.5	11
SR 62 GM SM 60 GM	150	NAT LP	2.53(#39) 1.51(#53)	810-2048 810-2059	5	10	4
					5	27.5	11
SR 62 GM (Australia)	150	NAT LP	2.53(#39) 1.61(#52)	810-2048 810-2063	5	9	3.6
					5	24	9.6
SM 80 GM	165	NAT LP	2.58(#38) 1.61(#52)	810-2062 810-2063	5	10	4
					5	27.5	11
<b>CE ONLY (Altitudes of 2000 feet or less)</b>							
MODEL	INPUT (kW)	GAS TYPE	ORIFICE MM (INCH)	ORIFICE PART NO.	QTY/ COLOR	EQUIPMENT PRESSURE	
						MBAR	INCH W.C.
SM20GM	15	G20	2,40	810-2060	2/BLUE	10,0	4,0
		G25	2,40	810-2060	2/BLUE	15,0	6,0
		G31	1,51	810-2059	2/RED	27,0	10,8
SM 35 (40) GM SR 42GM	26	G20	2,40	810-2060/*810-3101	3/BLUE	10,0	4,0
		G25	2,40	810-2060/*810-3101	3/BLUE	15,0	6,0
		G31	1,51	810-2059/*810-3102	3/RED	27,0	10,8
SR 52 GM SM 50 GM	30	G20	2,40	810-2060	4/BLUE	10,0	4,0
		G25	2,40	810-2060	4/BLUE	15,0	6,0
		G31	1,51	810-2059	4/RED	27,0	10,8
SR 62 GM SM 60 GM	37,5	G20	2,40	810-2060	5/BLUE	10,0	4,0
		G25	2,40	810-2060	5/BLUE	15,0	6,0
		G31	1,51	810-2059	5/RED	27,0	10,8
SM 80 GM	37,5	G20	2,40	810-2060	5/BLUE	10,0	4,0
		G25	2,40	810-2060	5/BLUE	15,0	6,0
		G31	1,51	810-2059	5/RED	27,0	10,8

\*SR42 units built after 4/07.

## 1.1 Functional Description (cont.)

An electromechanical millivolt gas valve regulates gas flow to the burner manifold. Dean millivolt fryers use a pilot ignition system to control burner firing.

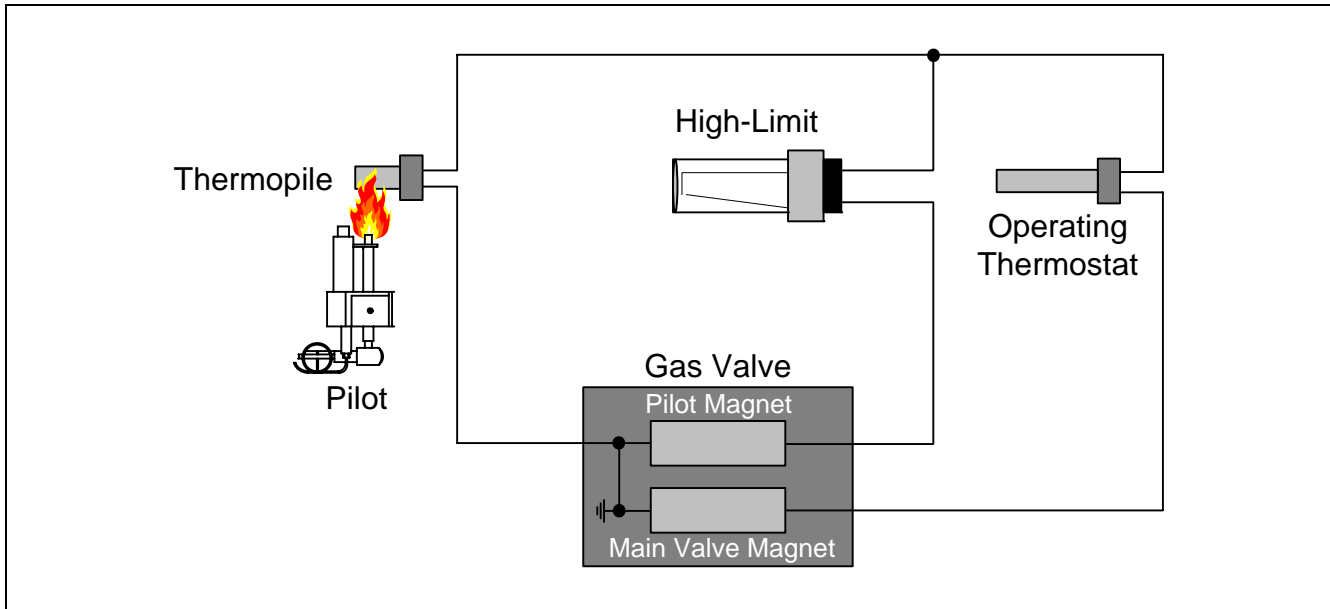

Functional diagram of a typical millivolt system.

### Pilot Ignition System

The pilot ignition system is made up of the pilot orifice, pilot hood, and a thermopile or thermocouple. The pilot serves two purposes: lighting the burner and heating the thermopile/thermocouple. In operation, the thermopile/thermocouple is in contact with the pilot flame and generates millivolts. The millivolt output passes through a normally closed high-limit switch and energizes the gas valve pilot coil, which in turn opens the pilot valve. If the pilot flame is extinguished, voltage is lost to the gas valve pilot coil and the pilot valve closes.

### Thermostats

Dean millivolt fryers are equipped with adjustable *operating thermostats*. The temperature at which the thermostat opens and closes is adjusted by turning a knob.

Dean millivolt fryers are also equipped with a *high-limit thermostat*. In the event that the fryer fails to properly control the oil temperature, the high-limit thermostat prevents the fryer from overheating to the flash point. The high-limit thermostat acts as a normally closed power switch that opens when exposed to temperatures above 410°F (210°C) for CE fryers and 435-450°F (224-232°C) for non-CE fryers. Once opened, the high limit must be manually reset before operating the fryer.

## 1.2 Accessing Fryers for Servicing



**Moving a fryer filled with cooking oil may cause spilling or splattering of the hot liquid.**

1. Drain all cooking oil from the fryer.
2. Shut off the gas supply to the unit and disconnect the unit from the gas supply.
3. Remove any attached restraining devices.



**Fryers must be at room temperature, empty of oil, and if fitted with legs, lifted during movement to avoid damage and possible bodily injury.**



**Hot shortening can cause severe burns. Avoid contact. Under all circumstances, oil must be removed from the fryer before attempting to move it to avoid oil spills, and the falls and severe burns that could occur. This fryer may tip and cause personal injury if not secured in a stationary position.**

4. Relocate the fryer for service accessibility. If fryer is equipped with legs, lift the fryer to relocate it. Damage to the leg or leg support channel can result if the fryer is not lifted when moving.
5. After servicing is complete, reconnect the unit to the gas supply and reattach the restraining devices.
6. Refill the frypot with cooking oil.

## 1.3 Cleaning the Gas Valve Vent Tube

1. Set the fryer power switch and the gas valve to the "OFF" position.
2. Carefully unscrew the vent tube from the gas valve. **NOTE:** The vent tube may be straightened for ease in removal.
3. Pass a piece of ordinary binding wire through the tube to remove any obstruction. Remove the wire and blow through the tube to ensure it is clear.
4. Reinstall tube and bend so that the opening is pointing downward.



## 1.4 Calibrating the Operating Thermostat

1. Ensure the frypot is filled to the proper level with oil before proceeding.
2. Light the pilot.
3. Set the temperature control knob to 350°F (177°C).
4. Let the burners cycle on and off automatically three times in order for the oil temperature to become uniform. If using solid shortening, stir to get all shortening in the bottom of the frypot melted.
5. Insert a good-grade thermometer or pyrometer probe into the oil, with the end near the fryer temperature-sensing bulb.

NOTE: The temperature-sensing probe is mounted on the frypot tube.

6. When the burner starts for the fourth time, the thermometer/pyrometer reading should be within the range 335-360°F (168-182°C). If not, calibrate as follows:
  - a. Remove the thermostat knob by pulling straight out on the knob with a firm, steady pull. The temperature adjusting screw is located in the middle of the thermostat shaft.
  - b. Insert a small-bladed flat-tipped screwdriver into the adjusting screw. Turn the adjusting screw in ¼-turn increments to adjust the temperature. Turning the screw clockwise decreases the temperature; turning it counter-clockwise increases the temperature. DO NOT allow the thermostat shaft to turn while turning the adjusting screw.
  - c. Recheck the thermometer/pyrometer reading the next time the burner comes on.
  - d. Repeat steps 4.b through 4.c until the thermometer/pyrometer reading remains within the range 335-360°F (168-182°C) through several cycles. If the thermostat cannot be calibrated, call a Factory Authorized Service Center for service.
  - e. Reinstall the thermostat knob.

## 1.5 Check Burner Manifold Pressure

**⚠ WARNING**

**This task should be performed by qualified service personnel only.**

1. Ensure that the gas valve knob is in the "OFF" position (non-CE), or press red button to turn gas valve off (CE).
2. Remove the pressure tap plug from the gas valve (see illustration below).

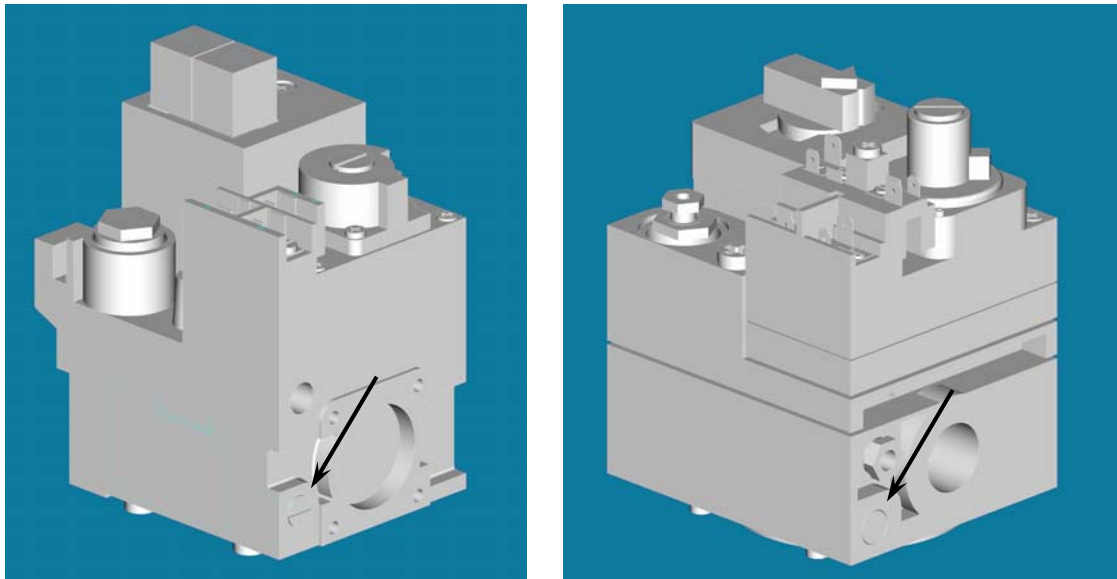

Pressure tap locations on CE gas valves (left) and non-CE gas valves (right).

3. Insert the fitting for a gas pressure-measuring device into the pressure tap hole.
4. Place the gas valve in the "Pilot" position (non-CE), or press white button and light pilot (CE). After the pilot is lit (turn non-CE gas valve to "ON" position), set thermostat knob to 350°F (177°C). When the burner lights and continues to burn, note gas pressure reading for correct pressure in accordance with the table on page 1-1.
5. To adjust burner gas pressure, remove the cap from the gas valve regulator and adjust to correct pressure.
6. Place the fryer power switch and the gas valve in the "OFF" position. Remove the pressure-measuring device fitting from the pressure tap hole and reinstall the pressure tap plug.
7. Repeat step 4 to continue fryer operation.

## 1.6 Adjusting the Pilot Flame

1. Remove the cover shown in the illustration below to access the pilot flame adjustment screw in the gas valve.

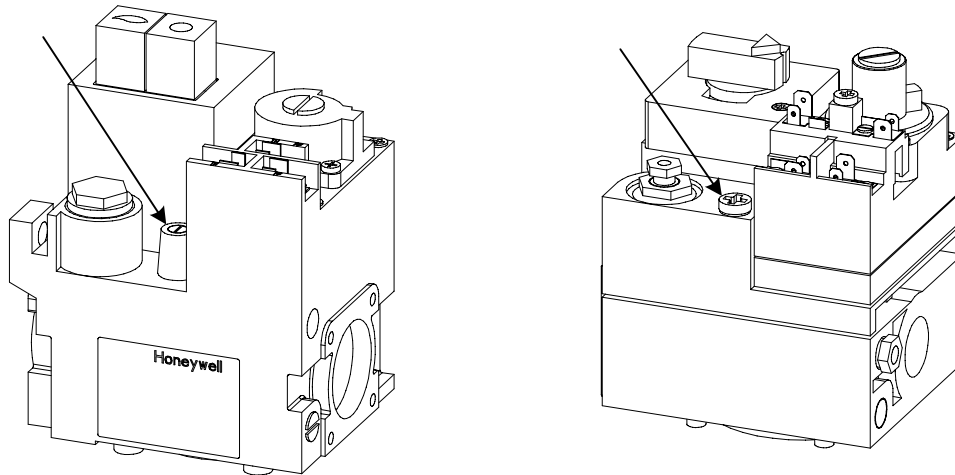

Pilot adjustment locations on CE gas valves (left) and non-CE gas valves (right).

2. Using a small, flat-tipped screwdriver, turn the pilot flame adjustment screw counterclockwise to increase the length of the flame or clockwise to decrease the length of the flame. Adjust the flame to a length of 1-½ inches (38 mm).
3. Reinstall the pilot flame-adjustment cover.
4. Five-tube millivolt fryers: Adjust the trailing pilot (adjustment valve located on the burner manifold) until a 1-½ inch (38 mm) flame is obtained.

## 1.7 Replacing Fryer Components

### 1.7.1 Replacing the Operating Thermostat

1. Drain the fryer and turn the gas off.
2. Remove the thermostat knob by pulling straight out on the knob with a firm, steady pull.
3. Disconnect the wires from the thermostat.
4. Remove the two mounting screws to release the thermostat control from its mounting bracket.
5. Remove the screws and clamp that secure the thermostat bulb to the frypot. Remove spring from bulb and reinstall on replacement thermostat bulb.

### 1.7.1 Replacing the Operating Thermostat (cont.)

6. First, loosen the capillary tube compression fitting until it slides freely on the capillary tube. Second, loosen the frypot pass-through nut until it slides freely on the capillary tube. Remove the capillary tube and bulb from the frypot.
7. Install the replacement thermostat capillary tube and bulb in the frypot. Apply a small amount of Loctite PST567 compound or equivalent to the threads of the frypot pass-through nut and screw the replacement thermostat securely into the frypot, being careful not to twist the capillary tube as the fitting is tightened. **DO NOT** tighten the capillary tube compression nut at this time.
8. Position the thermostat bulb in tube-mounted clamp and replace mounting hardware. Ensure probe bulb is properly positioned in the clamp ( $\frac{1}{4}$ " from burner tube) and screws are properly tightened.
9. Tighten the capillary tube compression nut once the capillary tube is properly positioned.  
NOTE: Once the compression nut is tightened, the capillary tube cannot be repositioned. If a mistake in installation has been made, a new thermostat will have to be installed.
10. Mount the thermostat control to the mounting bracket using the screws removed in Step 4.
11. Connect the wires disconnected in Step 3 to the thermostat.

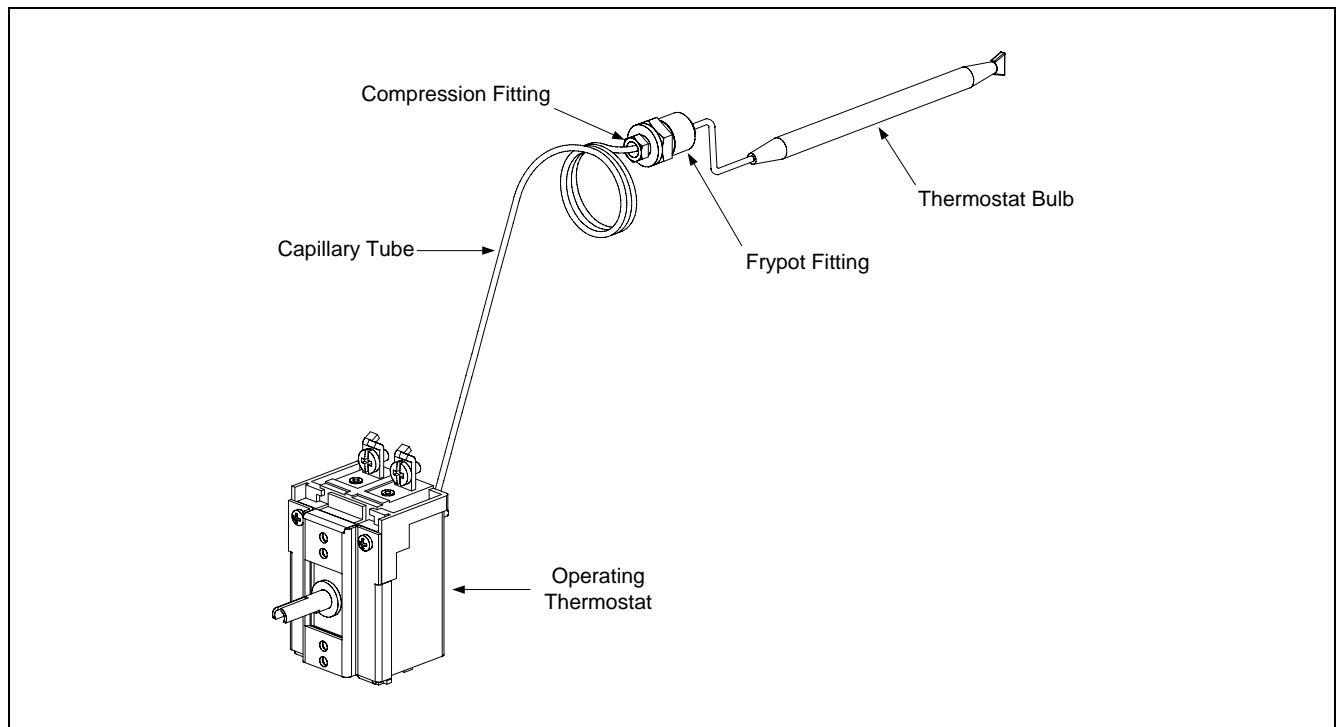

12. Install the thermostat knob on thermostat control shaft. Check thermostat calibration and calibrate if the range is outside of the recommended ranges in section 1.4.

### 1.7.2 Replacing the High-Limit Thermostat

1. Follow instructions for replacing operating thermostat, section 1.7.1, omitting steps 2 and 12.

### 1.7.3 Replacing the Gas Valve



**Drain the frypot or remove the handle from the drain valve before proceeding further.**

1. Disconnect fryer from the gas supply.
2. Disconnect wiring from the gas valve terminal block, marking each wire to facilitate reconnection.
3. Disconnect the pilot gas line fitting from the gas valve and remove the vent tube.
4. Disconnect the union that connects burner manifold and gas valve piping.
5. Remove all pipefittings from old gas valve and install on new gas valve. Apply a small amount of Loctite PST567 compound or equivalent to pipe threads prior to installing on new valve. Do not apply compound to the first two pipe threads. Doing so will clog and damage the gas valve.
6. Reinstall new gas valve following steps 1-4 in reverse.

### 1.7.4 Replacing the Frypot

1. Drain the frypot and disconnect the fryer from the gas supply.
2. Remove all accessories (e.g., frypot covers, drop-in probes, basket hangers, etc.).
3. Remove the screws from the cabinet back and remove it from the fryer.
4. Remove the screws attaching the flue cap to the frypot and lift the flue cap off the fryer.
5. Remove the door by lifting it upward to disengage the lower hinge pin from the hinge bracket. Retain any spacers between lower hinge and door for reassembly.
6. Remove the screws from the front cowling and remove the cowling by lifting up and out off the front lip of the frypot.
7. Remove the screws securing the flue to the frypot and remove it from the fryer.
8. Lift the frypot out of the cabinet, using care not to bump or damage the gas valve/burner assembly or the thermostat/high-limit. Set the frypot upside down on a clean surface for removal of the remaining components.

### 1.7.4 Replacing the Frypot (cont.)

9. Recover the drain valve, high-limit thermostat, operating thermostat, and burner manifold assembly from the failed frypot.
10. Clean the threads on the recovered parts, apply Loctite PST 567 or equivalent thread sealer, and install them on the replacement frypot.
11. Reverse Steps 1-9 to install the replacement frypot in the cabinet.

**For SUFF/UFF Filtration-equipped systems, consult the Decathlon Series Gas Fryers Service & Parts Manual (819-5922), Section 1.7.8, for detailed frypot-removal instructions.**

## 1.8 Troubleshooting and Problem Isolation

This section is intended to provide technicians with a general knowledge of the broad problem categories associated with this equipment, and the probable causes of each. With this knowledge, the technician should be able to isolate and correct any problem encountered.

Problems you are likely to encounter can be grouped into these broad categories:

1. Pilot failures
2. Improper burner functioning
3. Improper temperature control
4. Filtration Problems
5. Leaking

The probable causes and corrective actions for each category are discussed in the following sections.

### 1.8.1 Pilot Failures

When troubleshooting millivolt systems, always check these areas before performing diagnostic checks on either the Robertshaw or Honeywell systems:

- A. Inspect all wires and component leads for damage (heat, oil, moisture, etc.). On capillary tube-type thermostats, check for resistance on the thermostat lead wires. Wire nuts and other connectors cannot be present in a millivolt circuit as they can cause resistance. If resistance is found, solder the connectors to the wires or replace the wires.
- B. Clean and verify that all wire connections and gas valve terminal connections are tight.
- C. Check the length of the pilot flame (it should be about 1½-inches (38mm) long) and verify that it contacts the top one third of the thermopile. Clean the pilot orifice and adjust the pilot strength if needed.
- D. Measure thermopile output with no load (i.e., with the thermopile disconnected from the gas valve). Measurement must be made with a multimeter having a 0-1000 DC millivolt (MV) range. Light the pilot and have someone hold the gas cock knob in the depressed position. If the thermopile is a single lead (coaxial) type, measure from the lead's end contact to its screw-in threads. If the thermopile has two leads, measure across the end terminals. The reading should be within the range of 500-800 millivolts. If not, replace the thermopile.

Performing diagnostic checks on Robertshaw and Honeywell valves are described on the next page.

## ROBERTSHAW-UNITROL 7000 SYSTEM CHECK

### 1. Complete System Check

With thermostat contacts closed and gas cock dial in the "ON" position, the main burner should ignite. Measure the reading between the 2 & 3 terminals. If the reading is more than 100MV, replace the gas valve.

### 2. System Resistance Check

With thermostat contacts closed and main burner "ON", measure the millivolt reading between the 1 and 3 terminals. The reading should be less than 80MV. If not, recheck the thermostat leads and connections. Replace with new or heavier gauge wires if necessary. If the reading is still greater than 80MV, replace the thermostat.

### 3. Automatic Pilot Dropout Check

With the thermostat contacts open, hold the gas cock knob depressed with the pilot lit until the maximum millivolt output is observed between the 1 and 2 terminals. Then extinguish the pilot and observe the meter. The sound of the pilot magnet dropping should be audible. This dropout should occur between 120MV and 30MV. If it occurs outside these limits, change the gas valve.

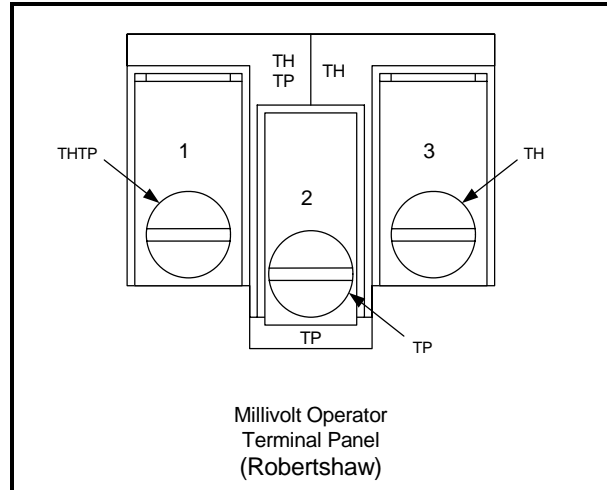

Test	Meter Setting	Meter Leads On Terminals	Acceptable Results
1	MV	2 & 3	<100MV
2	MV	1 & 3	<80MV
3	MV	1 & 2	30-120MV

## HONEYWELL SYSTEM CHECK

### 1. Complete System Check

With thermostat contacts closed and gas cock dial in the "ON" position, main burner should ignite. If not, measure across terminals 2 and 3 as indicated in the diagram. If the reading is more than 180MV, replace the gas valve.

### 2. System Resistance Check

With thermostat contacts closed and main burner "ON", measure the millivolt reading between terminals 1 and 3 as indicated in the diagram. The reading should be 220MV or less. If not, recheck thermostat leads and connections. Replace with new or heavier gauge wires if necessary. If the reading is still greater than 220MV, replace the thermostat.

### 3. Automatic Pilot Dropout Check

With the thermostat contacts open, hold the gas cock knob depressed with the pilot lit until the maximum millivolt output is observed between terminals 1 and 2. Then extinguish the pilot and observe the meter. The sound of the pilot magnet dropping should be audible. This dropout should occur between 110MV and 36MV. If it occurs outside these limits, change the gas valve.

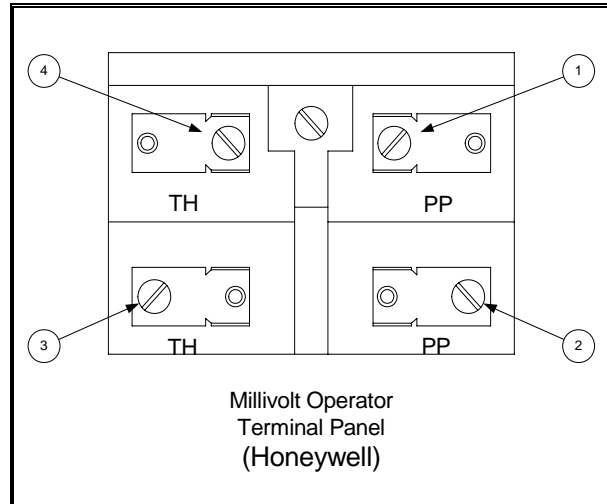

Test	Meter Setting	Meter Leads On Terminals	Acceptable Results
1	MV	2 & 3	<180MV
2	MV	1 & 3	<220MV
3	MV	1 & 2	36-110MV

Pilot failures fall into one of two categories – failure to light or failure to remain lit.

### Pilot Fails to Light

1. Gas is not being supplied to the valve: Check for a closed gas cutoff valve upstream of the gas valve. Also verify that the gas line quick disconnect fitting at the rear of the fryer (if so equipped) is properly connected.
2. Blocked pilot orifice: If gas is reaching the valve but the pilot will not light, check for an obstruction in the pilot orifice, especially in new installations. If the orifice is clear, check to be sure that the pilot adjustment screw is not completely closed.

### Pilot Does Not Remain Lit When Gas Valve Knob is Released

The gas valve used on Dean millivolt fryers has a pair of normally open coils (electromagnetic switches) that close when low voltage is applied to them. If the coils do not close, the valve will not open to supply gas to the pilot or to the burner manifold. Turning the gas valve knob to the pilot position and pressing it in bypasses the pilot coil, allowing the pilot to be lit. The pilot flame heats the thermopile, which generates the voltage required to close the coils. If the pilot flame goes out when the knob is released, there are four probable causes:

1. **Open or grounded high-limit:** The high-limit thermostat functions as a normally closed switch. If the high-limit is open or grounded, the gas valve coil will not pull in and no gas will be supplied to the pilot or to the burner manifold.

**Check and Corrective Action:** Detach the high-limit leads from the gas valve and check for continuity. See page 1-10. If the high-limit fails the continuity check, it must be replaced.

2. **Loose/corroded wiring connections on high-limit or thermopile:** This has the same effect as a grounded or open high-limit. If the gas valve coils do not receive the appropriate voltage from the thermopile, they will not close and no gas will be supplied to the pilot or to the burner manifold.

**Check and Corrective Action:** Check wiring connections for corrosion and tightness. Check terminals to verify that they are securely attached to their leads.

3. **Low or no voltage out of thermopile:** If the pilot flame does not surround the tip of the thermopile, it will not generate sufficient voltage to the gas valve coils for them to close. No gas will be supplied to the pilot or to the burner manifold.

**Checks and Corrective Actions:** Observe pilot flame located between the middle burners on the frypot. If the pilot flame is less than 1-½ inches (38 mm) adjust the pilot flame in accordance with Section 1.6. If the flame is being blown away from the thermopile, eliminate the draft that is causing the problem.

If the pilot flame correctly surrounds the tip of the thermopile, see D on Page 1-9.

4. **Malfunctioning gas valve:** If either of the coils in the gas valve fails, no gas will be supplied to the pilot or to the burner manifold.

**Check and Corrective Action:** See page 1-10 for check procedures to see if the gas valve has failed. Instructions to replace the gas valve are found in section 1.7.3.



## 1.8.2 Improper Burner Functioning

*Fluctuating flame intensity* is normally caused by improper or fluctuating incoming gas pressure, but may also be the result of variations in the kitchen atmosphere. Variation in the kitchen atmosphere is usually caused by air conditioning and/or ventilation units starting and stopping. Changes in airflow patterns can also affect flame intensity. If the incoming gas pressure is correct and stable, check for variations in the kitchen atmosphere.

*Flames "rolling" out of the fryer* are usually an indication of negative pressure in the kitchen. Air is being sucked out of the fryer enclosure and the flames are literally following the air. If negative pressure is not the cause, check for high burner-manifold gas pressure. An obstructed flue, which prevents the fryer from properly exhausting, may also be the cause.

An *excessively noisy burner*, especially with *flames visible above the flue opening*, may indicate that the burner gas pressure is too high, the gas valve vent tube is blocked, or the tube diffusers are damaged or worn out. If the gas pressure is correct, the vent tube is unobstructed, and the diffusers are in good condition, the gas valve regulator is probably defective.

Occasionally a burner may appear to be operating correctly, but the fryer has a *slow recovery rate* (the length of time required for the fryer to increase the oil temperature from 275°F to 325°F (135°C to 163°C)). The primary causes of this are low burner manifold pressure and/or misaligned burners. If both of these causes are ruled out, the probable cause is a gas valve regulator that is out of adjustment. Refer to the **Check Burner Manifold Pressure** procedure in section 1.5.

## 1.8.3 Improper Temperature Control (i.e., failure to control at set point)

Temperature control is a function of several interrelated components, each of which must operate correctly. The principle component, however, is the thermostat.

The thermostat must be checked periodically to ensure that it is in calibration. Refer to Calibrating the Operating Thermostat in section 1.4 for the procedure.

If the thermostat is properly calibrated, the probable causes are damage to the thermostat bulb, kinking of the capillary tube, and broken or loose wiring. Inspect the thermostat components for visible damage.

If there are dents in the bulb, if the capillary is kinked, or if there is obvious damage to the leads, the thermostat should be replaced.

If there is no obvious damage to the thermostat, turn off the gas valve and allow the cooking oil to cool to at least 15 degrees below the thermostat setting. Disconnect the thermostat leads from the gas valve and check for continuity. If the thermostat fails the continuity check, it must be replaced.

## 1.8.4 Filtration Problems

The majority of filtration problems arise from operator error. One of the most common errors is placing the filter paper on the bottom of the filter pan rather than over the filter screen.

Whenever the complaint is "the pump is running, but no oil is being filtered", check the installation and size of the filter paper. Verify that the O-ring on the slip-connection is in good condition. A missing or worn O-ring allows the pump to suck air, decreasing its efficiency.

If the pump motor overheats, its thermal overload will trip and the motor will not start until it is reset. If the pump motor does not start, press the red reset switch located on the rear of the motor. Also, reset the filter circuit breaker located under the fryer control panel. If the pump then starts, something caused the motor to overheat. Maybe several frypots were filtered one after the other and the pump got hot. Letting the motor cool down for at least a half-hour is all that is required in this case. More often, the pump overheated for one of the following reasons:

- If solid shortening is used: Shortening solidified in the pan or filter lines.
- The operator attempted to filter unheated oil. Cold oil is thicker and causes the pump motor to work harder and overheat.

If the motor runs but the pump does not, there is a blockage in the pump. Incorrectly sized or installed paper allows food particles and sediment to pass through the filter pan and into the pump. When sediment enters the pump, the gears bind up causing the motor to overheat, tripping the thermal overload. Solidified shortening in the pump will produce the same result.

A pump seized by debris or hard shortening must be disassembled, cleaned and reassembled.

1. Disconnect power to the filter system.
2. Remove the front cover of the pump to access the gears inside (see illustration- 8-GPM pump shown), if the pump is accessible while still inside the cabinet. If the front cover is not accessible, the pump must be removed from the pump motor (remove input/output plumbing from the pump prior to removing pump). Remove three setscrews to disengage the pump from the motor.

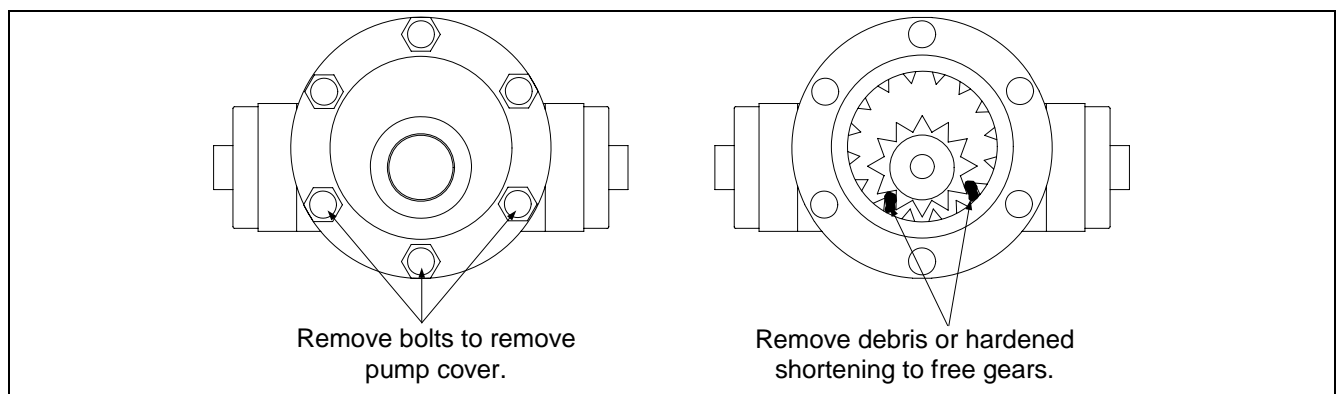

### 1.8.4 Filtration Problems (cont.)

3. Prior to reassembly, the inside housing must be clean and free of any sediment or debris. Failure to completely clean the inside housing and ring gear will cause gear binding after reassembly.

Incorrectly sized or installed paper will allow food particles and sediment to pass through and clog the suction tube on the bottom of the filter carriage. Particles large enough to block the suction tube may indicate that the crumb tray is not being used.

Pan blockage can also occur if shortening is left in the pan and allowed to solidify. Heater strips (if equipped) on the oil return plumbing are designed to prevent solidification of shortening left in the plumbing. Heater strips will not melt or prevent solidification of shortening in the pan.

Blockage removal can be accomplished by forcing the item out with an auger or drain snake. Compressed air or other pressurized gases should not be used to force out the blockage.

The electronics of the SUFF/UFF filtration systems are simple and straightforward. Microswitches, attached to handles for each vat and wired in parallel, provide the 24 VAC required to activate the pump relay coil when the handles are moved to the ON position. The activated pump relay coil pulls in the pump motor switch, supplying power to the pump motor.

Filter systems equipped with oil-return heaters are wired into the 120 VAC source, which remain energized as long as the unit is plugged in.

### 1.8.5 Leaking

Leakage of the frypot usually will be due to improperly sealed high-limits, thermostats, or drain fittings. When installed or replaced, each of these components must be sealed with Loctite PST567 sealant or equivalent to prevent leakage. In very rare cases, a leak may develop along one of the welded edges of the frypot. When this occurs, the frypot must be replaced.

If the sides and/or ends of the frypot are coated with oil, the most likely cause is spillage over the top of the frypot rather than leakage.

Frypot locations (indicated by arrows) where potential leaks could occur.

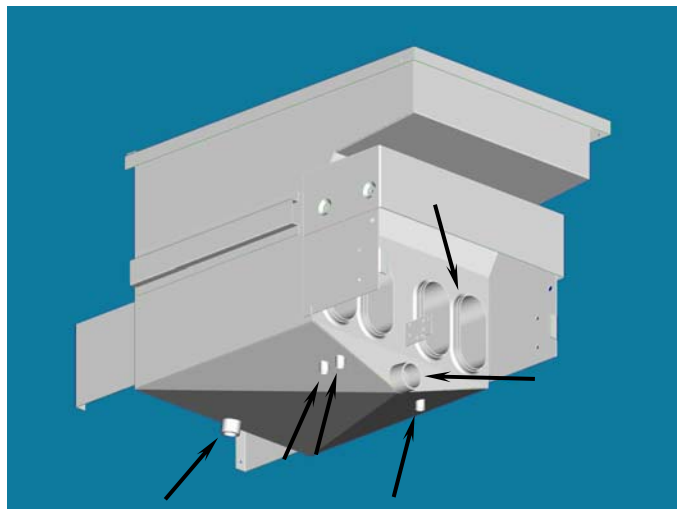

# 1.9 Wiring Diagrams

## 1.9.1 Current Production Units with Honeywell Gas Valve (Non-CE)

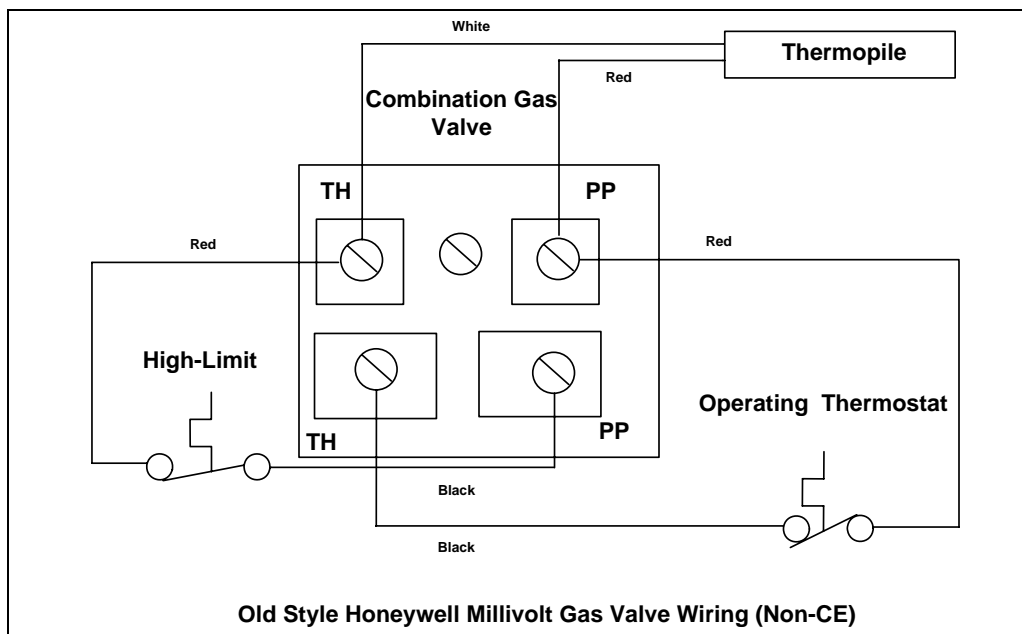
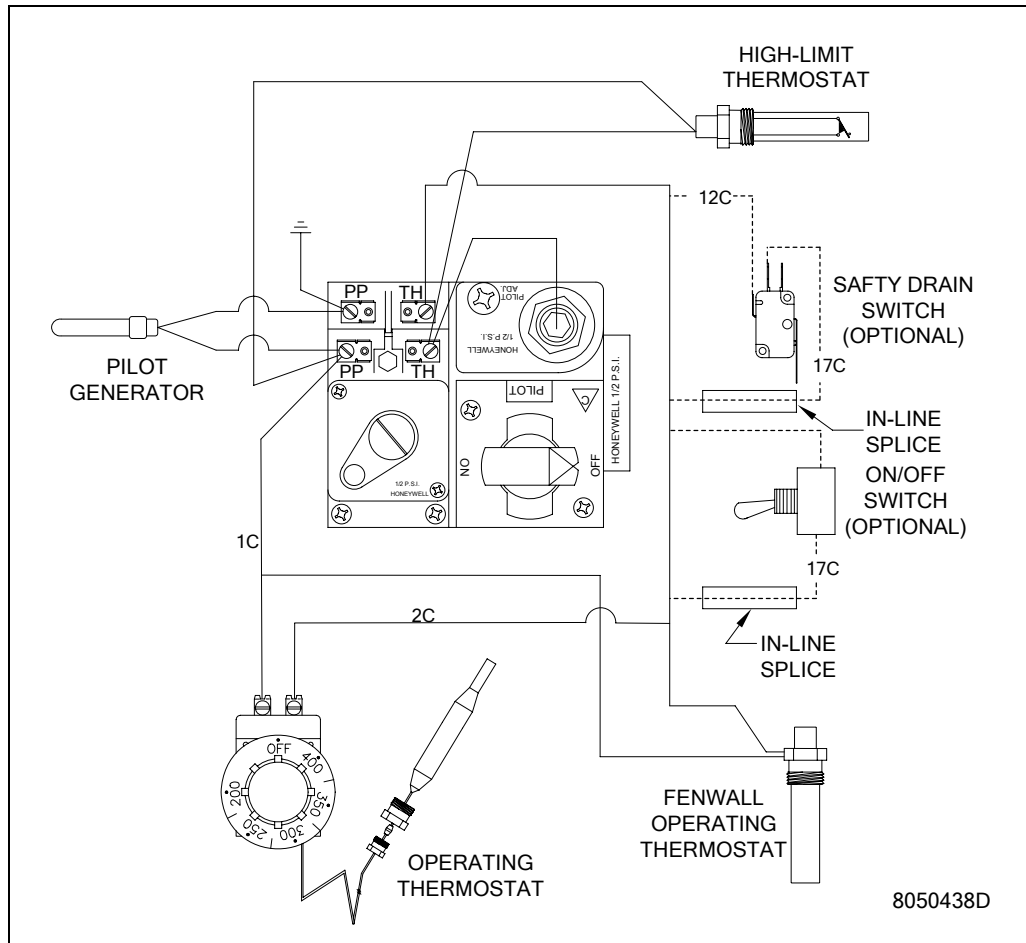

### 1.9.2 Current Production Units with Honeywell Gas Valve (CE)

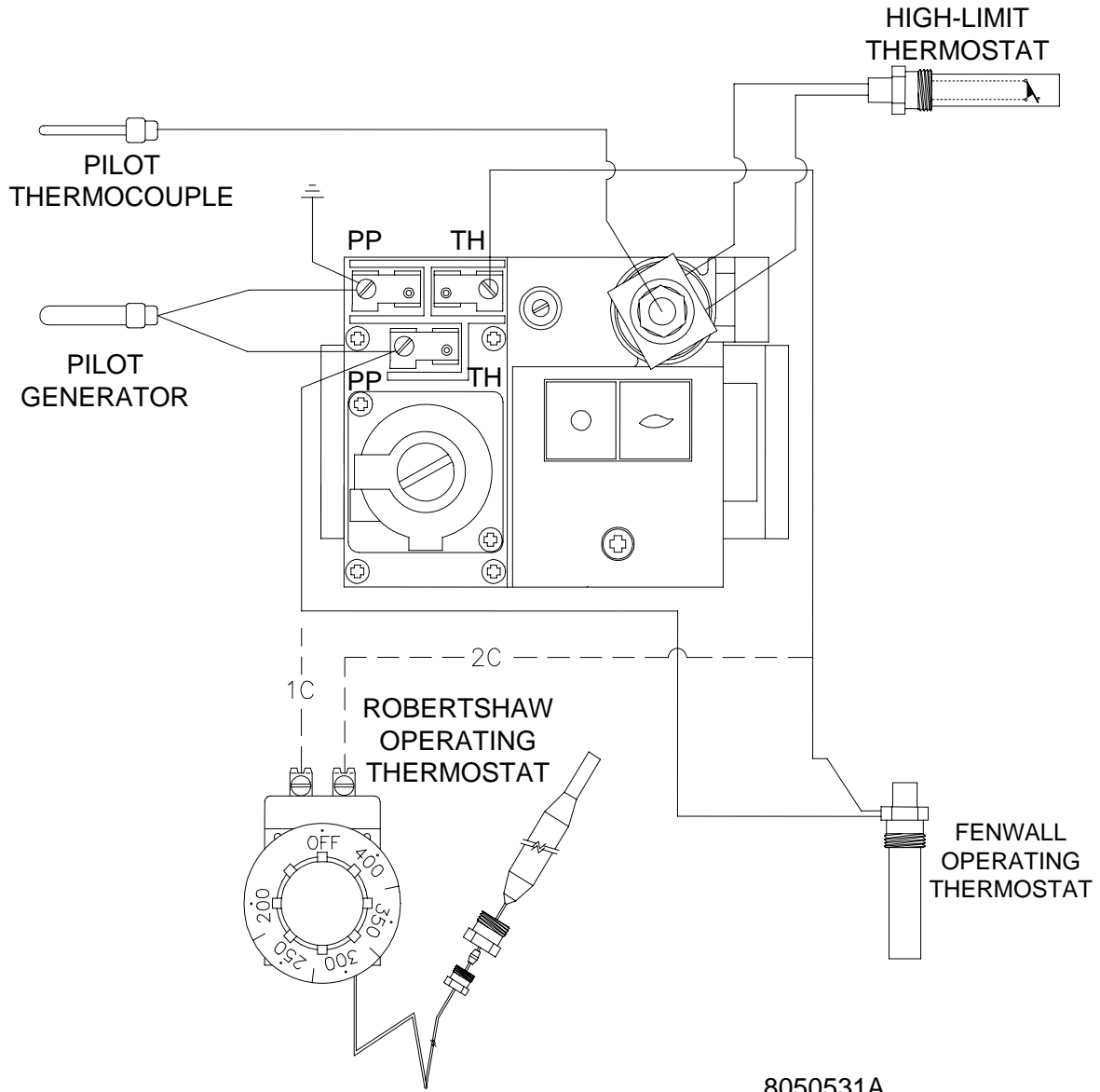

8050531A

### 1.9.3 Current Production Units with Robertshaw Gas Valve (After May, 2002)

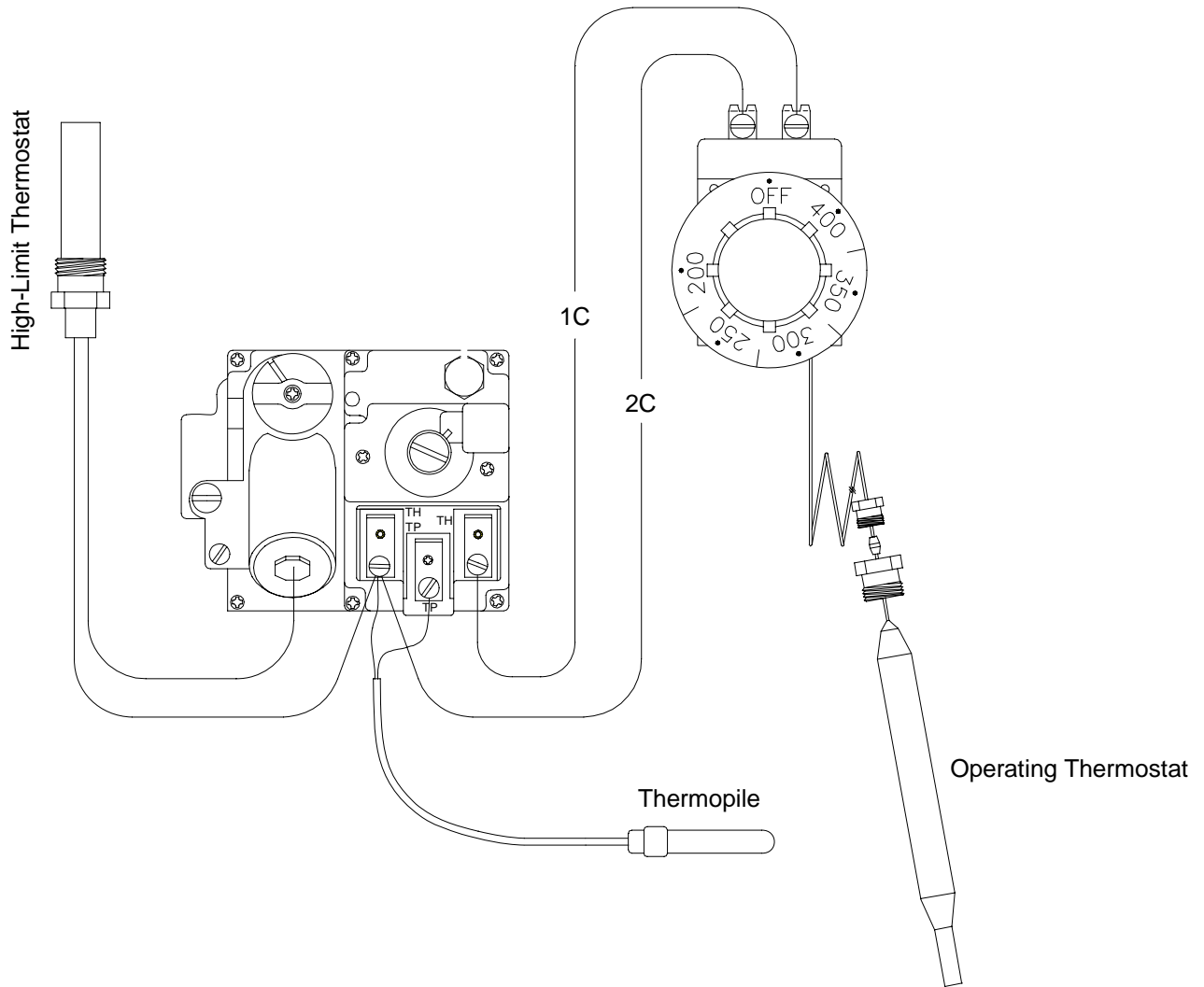



# DEAN MILLIVOLT GAS FRYERS

## CHAPTER 2: PARTS LIST

### 2.1 Cabinetry Components, Single Fryers

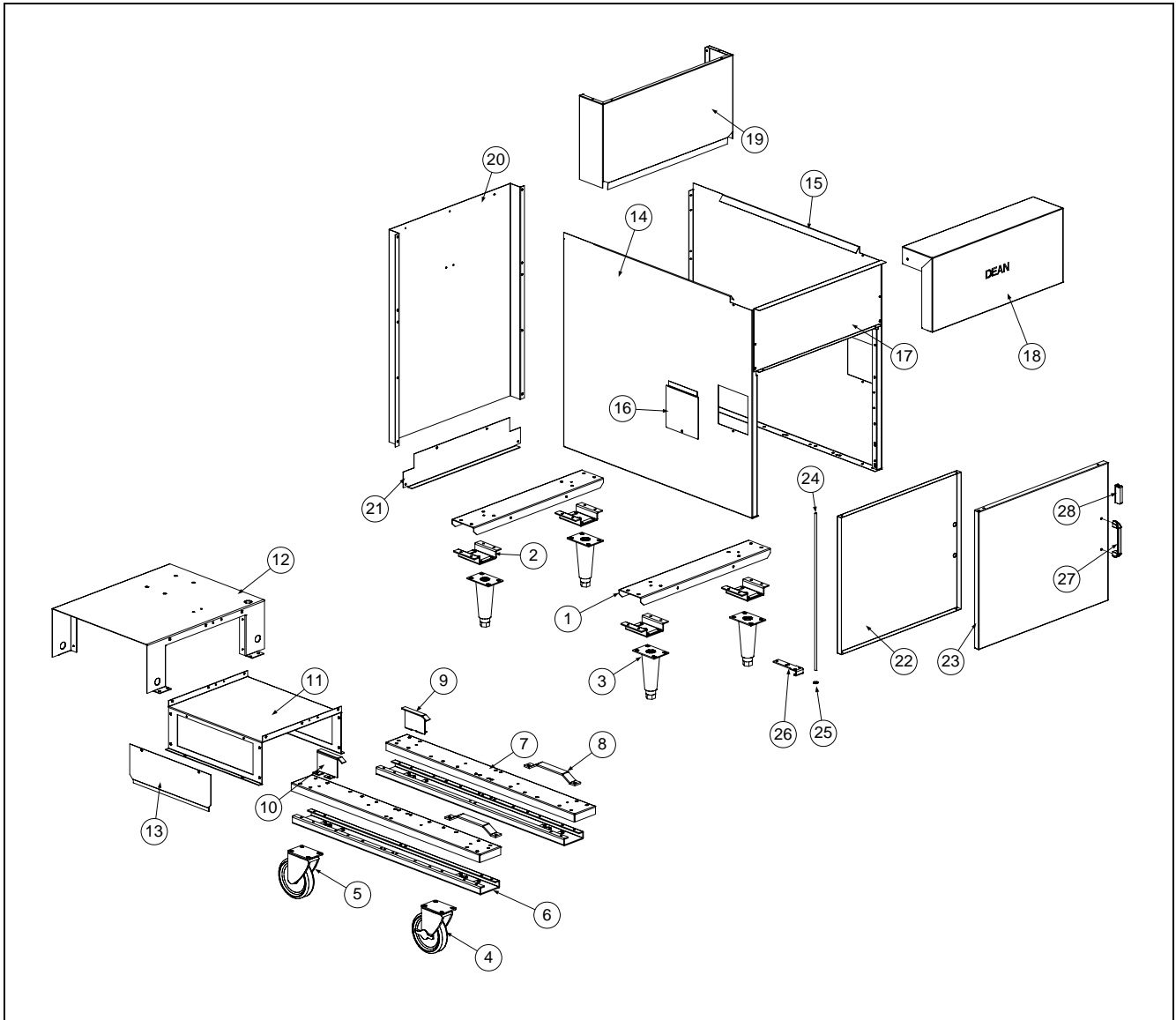

ITEM	PART #	COMPONENT
*	810-2793	Basket Hanger SR142 ( <b>Hook Over the Flue</b> ) Thumbscrews not needed
*	200-1360	Basket Hanger SR42 (Thumbscrew 809-0171, Cage Nut 826-1351)
*	210-1595	Basket Hanger SM-50 Single (Use 210-3131 for double)
*	210-5109	Joiner Strip SM20, SM50
1		<b>Channel, Base- Front &amp; Rear (Non-Filtration Single Fryers)</b>
*	12-0373	Channel, Base- Front & Rear- SR38G obsolete
*	200-1118	Channel, Base- Front & Rear- SR42G, SR52G, SM220G SM35G, SM40G, SM50G
*	200-5655	Channel, Base- Front & Rear-SR62G
*	200-3269	Channel, Base- Front & Rear- SM20G
*	200-2493	Channel, Base- Front & Rear- SM60G
*	200-2686	Channel, Base- Front & Rear- SM80G
2	823-3248	Support, Leg (Use Where Applicable)
3	806-5043	Leg, Adjustable- With Mounting Plate- <u>All Millivolt Fryers</u>

\* Not Illustrated



**DEAN MILLIVOLT GAS FRYERS  
CHAPTER 2: PARTS LIST**

**2.1 Cabinetry Components, Single Fryers (cont.)**

ITEM	PART #	COMPONENT
4	810-0357	Caster, Swivel- With Brake- <u>All Millivolt Fryers</u>
5	810-0356	Caster, Swivel- Without Brake- <u>All Millivolt Fryers</u>
<b>SUFF Base Components- SM Series With SUFF Filtration</b>		
6	823-3791	Support, Leg- Left- SUFF 50- <b>SM40G, SM50G</b>
*	823-3792	Support, Leg- Right- SUFF 50- <b>SM40G, SM50G</b>
*	823-3724	Support, Leg- Left & Right- SUFF 60/80- <b>SM60G, SM80G</b>
7	202-3529	Base, Channel- Right- SUFF 50- <b>SM40G, SM50G</b>
*	201-3259	Base, Channel- Left- SUFF 50- <b>SM40G, SM50G</b>
*	200-3459	Base, Channel- Right & Left- SUFF 60/80- <b>SM60G, SM80G</b>
8	210-3636	Slide, Front- SUFF Filter, All Systems
9	823-3751	Slide, Rear, Left- SUFF Filter- <b>SM60G, SM80G</b>
*	823-3788	Slide, Rear, Left- SUFF Filter- <b>SM50G</b>
10	823-3752	Slide, Rear, Right- SUFF Filter- <b>SM60G, SM80G</b>
*	823-3789	Slide, Rear, Right- SUFF Filter- <b>SM50G</b>
11	200-3522	Base, Lower Filter- SUFF 50- <b>SM40G, SM50G</b>
*	200-3494	Base, Lower Filter- SUFF 60- <b>SM60G</b>
*	200-3403	Base, Lower Filter- SUFF 80- <b>SM80G</b>
12	823-3783	Base, Upper Filter- SUFF 50- <b>SM40G, SM50G</b>
*	823-3765	Base, Upper Filter- SUFF 60- <b>SM60G</b>
*	823-3745	Base, Upper Filter- SUFF 80- <b>SM80G</b>
13	200-3524	Cover, Electrical Access- SUFF 50- <b>SM40G, SM50G</b>
*	200-3461	Cover, Electrical Access- SUFF 60- <b>SM60G, SM80G</b>
14		<b>Side Panel, Left</b>
*	12-0380-1	Side Panel, Left- Painted Aluminum- <b>SR38G <i>obsolete</i></b>
*	201-1137SP	Side Panel, Left- Painted Aluminum- <b>SR42G, SR52G (Use 202-5693SP for SR62G)</b>
*	211-3329	Side Panel, Left- <b>SM20G</b>
*	201-2858	Side Panel, Left- Painted CRS- <b>SM35G, SM50G</b>
*	201-1299	Side Panel, Left- Painted CRS- <b>SM50GDD</b>
*	211-2076	Side Panel, Left- S/S- <b>SR42G, SM35G, SM50G (Use 211-5693 for SR62G)</b>
*	211-2532	Side Panel, Left- S/S- <b>SM60G, SM80G</b>
15		<b>Side Panel, Right</b>
*	12-0380-2	Side Panel, Right- Painted Aluminum- <b>SR38G <i>obsolete</i></b>
*	202-1137	Side Panel, Right- Painted Aluminum- <b>SR42G, SR52G (Use 202-5693SP for SR62G)</b>
*	212-3329	Side Panel, Right- <b>SM20G</b>
*	202-2858	Side Panel, Right- Painted CRS- <b>SM35G, SM50G</b>
*	202-1299	Side Panel, Right- Painted CRS- <b>SM50GDD</b>
*	212-2076	Side Panel, Right- S/S- <b>SR42G, SM35G, SM50G (Use 212-5693 for SR62G)</b>
*	212-2532	Side Panel, Right- S/S- <b>SM60G, SM80G</b>
16	210-2804	Duct, Door Access- S/S- <u>All Millivolt Fryers</u>
*	200-1471	Duct, Door Access- Painted- <u>All Millivolt Fryers</u>
17	12-0311	Back, Control Panel- <b>SR38G <i>obsolete</i></b>
*	200-1121	Back, Control Panel- <b>SR42G, SR52G, SM220G (Use 200-3003 for SR62G)</b>
*	200-1676	Back, Control Panel- <b>SM35G, SM40G, SM50G</b>
*	200-3558	Back, Control Panel- <b>SM50GDD</b>
*	200-2856	Back, Control Panel- <b>SM60G</b>
*	200-1213	Back, Control Panel- <b>SM60G</b>
*	200-3004	Back, Control Panel- <b>SM80G</b>
18	12-0309-2	Top Cap (Front Canopy)- <b>SR38G <i>obsolete</i></b>
*	210-1141	Top Cap (Front Canopy)- <b>SR42G, SR52G, SM35G, SM40G, SM50G</b>
*	07-0132	Top Cap (Front Canopy)- <b>SM20G <i>obsolete</i></b>
*	824-1033	Top Cap (Front Canopy)- <b>SM220G</b>

\* Not Illustrated

**DEAN MILLIVOLT GAS FRYERS  
CHAPTER 2: PARTS LIST**

**2.1 Cabinetry Components, Single Fryers (cont.)**

<b>ITEM</b>	<b>PART #</b>	<b>COMPONENT</b>
*	210-3419	Top Cap (Front Canopy)- <b>SM50GDD</b>
*	210-2821	Top Cap (Front Canopy)- <b>SM60G, SR62G</b>
*	210-2811	Top Cap (Front Canopy)- <b>SM80G</b>
19	12-0366-2	Flue Cap- <b>SR38G</b> <i>obsolete</i>
*	823-4175	Flue Cap- <b>SR42G, SR52G (After Feb. 2003)</b> <i>obsolete Use 230-0031</i>
*	823-4437	Flue Cap- <b>SR62G</b>
*	823-3467	Flue Cap- <b>SM35G, SM40G (SR42G, SR52G Prior To Feb. 2003)</b> <i>obsolete</i>
*	823-3700	Flue Cap- <b>SM20G</b>
*	823-3702	Flue Cap- <b>SM220G</b>
*	823-3521	Flue Cap- <b>SM50G</b>
*	823-3575	Flue Cap- <b>SM50GDD</b>
*	823-3635	Flue Cap- <b>SM60G</b>
*	823-3512	Flue Cap- <b>SM80G</b>
20	12-0401	Back, Upper Cabinet- <b>SR38G</b> <i>obsolete</i>
*	200-1123	Back, Upper Cabinet- <b>SR42G, SR52G, SM35G, SM50G</b>
*	200-1377	Back, One-Piece Cabinet- <b>SM35G, SM50G</b>
*	200-1674	Back, Upper Cabinet- <b>SM50G (SUFF), SM220G</b>
*	200-1213	Back, Upper Cabinet- <b>SM60G / SR62G</b>
*	200-2683	Back, Upper Cabinet- <b>SM80G</b>
21	12-0402	Back, Lower Cabinet- <b>SR38G</b> <i>obsolete</i>
*	200-1126	Back, Lower Cabinet- <b>SM35G, SM50G, SM50GDD</b>
*	200-1327	Back, Lower Cabinet- <b>SM60G</b>
*	210-2684	Back, Lower Cabinet- <b>SM80G</b>
<b>Door Assembly Components</b>		
22	200-3807	Panel, Inner Door- <b>SM20G</b>
*	200-1379	Panel, Inner Door- <b>SM220G, SM35G, SM40G, SM50G</b>
*	200-1185	Panel, Inner Door- <b>SM60G</b>
*	200-2688	Panel, Inner Door- <b>SM80G</b>
23	12-0308-2	Panel, Door- <b>SR38G</b> <i>obsolete</i>
*	210-4770	Panel, Door- <b>SR42G, SR52G (Assembly 106-3150SP)</b>
*	210-5642	Panel, Door- <b>SR62G (Assembly 106-3444SP)</b>
*	106-4728	Door Assembly, Right with Liner- <b>SM50</b>
*	210-3805	Panel, Outer Door- <b>SM20G (Assembly 106-2482SP)</b>
*	210-2869	Panel, Outer Door- <b>SM220G, SM35G, SM40G, SM50G (Assembly 106-1754SP)</b>
*	210-1424	Panel, Outer Door- <b>SM60G</b>
*	210-1151	Panel, Outer Door- <b>SM80G (Assembly 106-1698SP)</b>
24	200-1301	Pin, Door- All Millivolt Fryers. <i>(Use 826-1343 for Springs qty. 10)</i>
*	106-1698SP	Pin, Door Assembly- All Millivolt Fryers (short)
25	809-0413	Spacer, Nylon- All Millivolt Fryers
26	200-1307	Hinge, Door- Lower- All SR Series Fryers
*	200-1675	Hinge, Door- Lower- All SM Series Fryers
27	810-0180	Handle, Door- Chrome- All SM Series Fryers
*	809-0918	Screw, #10-24 x 1/2" (Use With 810-2105)
*	809-0191	Washer, Lock 1/4" (Use With 810-2105)
*	810-1422	Handle, Wireform- Door- <b>SR42G, SR52G (Use 810-2030 before Jan. 03)</b>
*	826-1379	Screw, #10 x 1/2" Round Phillips (Qty: 10) (Use With 810-1422)
28	810-0066	Catch, Magnetic Door- All Millivolt Fryers
*	823-3225	Splash Guard 42's & 50's <i>(Use 823-4767 for 60's &amp; 80's)</i>
*	200-3663	Striker Plate all models except SR42
*	210-2897	Striker Plate <b>SR42</b>
*	803-0197	Fryers Friend Cleanout Tool

\* Not Illustrated

## DEAN MILLIVOLT GAS FRYERS CHAPTER 2: PARTS LIST

### 2.2 Cabinetry Components, Multi-Battery Frying Systems

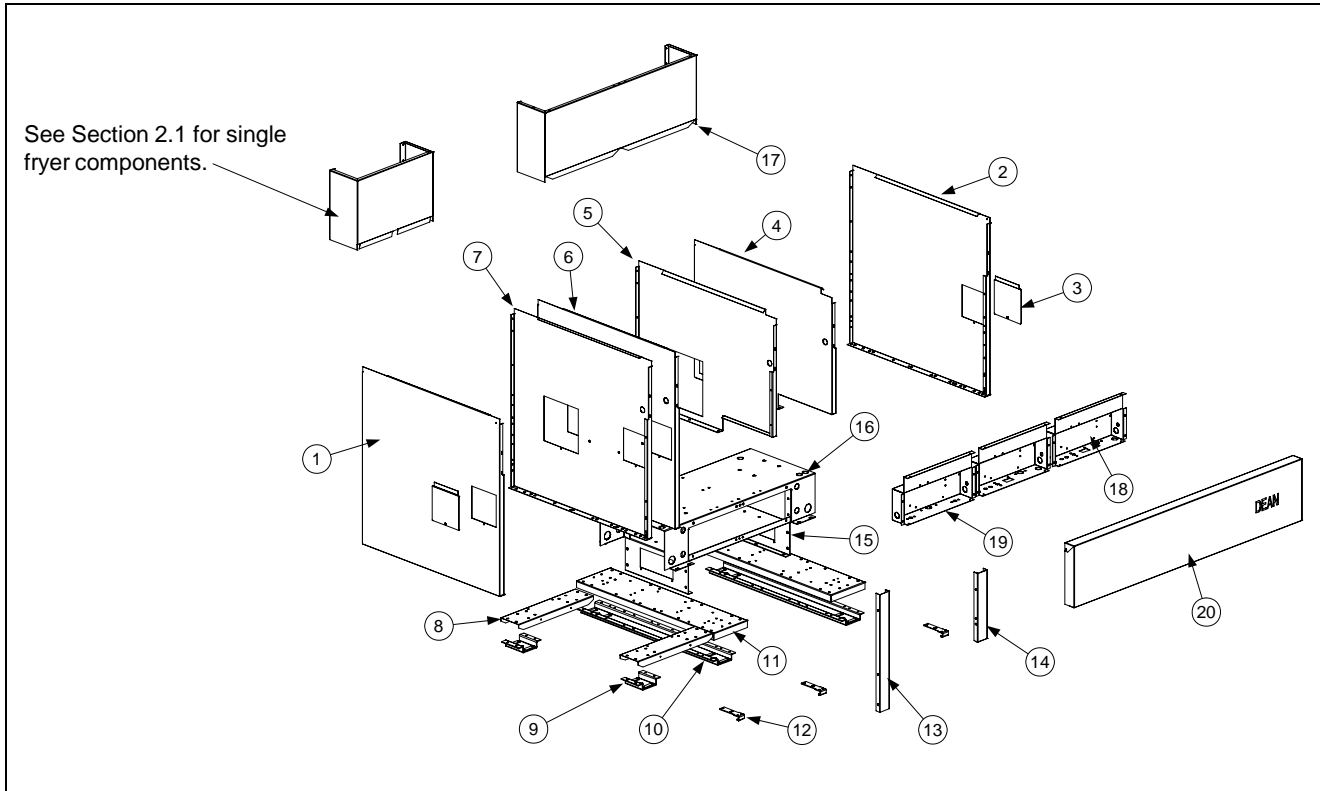

ITEM	PART #	COMPONENT
1	211-3261	Side, Left- S/S- (Use When SM20G Is On End)
*	211-2787	Side, Left- S/S- (Use When SM50G Is On End)
*	201-3369	Side, Left- Painted (Use When SM50G is On End)
2	212-3261	Side, Right- S/S- (Use When SM20G Is On End)
*	212-2787	Side, Right- S/S- (Use When SM50G Is On End)
*	202-3369	Side, Right- Painted (Use When SM50G is On End)
3	210-2804	Duct, Door Access- <u>All SM Series Multi-Battery Fryers</u>
4	202-2799	Panel, Inner- SUFF Base-Right- <b>SM50G</b>
5	201-2799	Panel, Inner- SUFF Base-Left- <b>SM50G</b>
6	202-3268	Panel, Inner- Right- <b>SM20G To SM50G</b>
7	201-3268	Panel, Inner- Left- <b>SM20G To SM50G</b>
8	200-1148	Base Channel, Front & Rear- <b>SM220G, SM50G (See Section 2.1 For Additional Single Fryer Base Channel Components)</b>
*	200-3154	Channel, Double- Front & Rear- <b>SM80G Systems (4-Battery)</b>
9	823-3248	Support, Leg- <u>All SM 60/80 Series Multi-Battery Fryers With UFF</u>
10	823-3539	Support, Leg- <u>All SM 20/50 &amp; 50 Series Multi-Battery Fryers With UFF</u>
11	200-2783	Channel, Filter Base- <u>All SM 20/50 Series UFF-Equipped</u>
*	200-1198	Channel, Filter Base- <u>All SM60G-80G Series UFF-Equipped</u>
12	200-1675	Bracket, Lower Hinge- <u>All SM Series UFF-Equipped</u>
13	200-1393	Channel, Lower Joiner- <u>All SM 20/50 &amp; 50 Series Multi-Battery Fryers With UFF</u>
14	200-2308	Post, Door- <u>All SM 20/50 &amp; 50 Series Multi-Battery Fryers With UFF</u>

\* Not Illustrated

**DEAN MILLIVOLT GAS FRYERS  
CHAPTER 2: PARTS LIST**

**2.2 Cabinetry Components, Multi-Battery Frying Systems**

<b>ITEM</b>	<b>PART #</b>	<b>COMPONENT</b>
15	200-2830	Base, Filter Frame- Lower- <u>SM 20/50 &amp; 50 Series Multi-Battery Fryers w/ UFF</u>
16	200-2785	Base, Filter Frame- Upper- <u>SM 20/50 &amp; 50 Series Multi-Battery Fryers w/ UFF</u>
17	823-3634	Fluecap, <b>SM250G</b>
*	823-3705	Fluecap, <b>SM20/20/50G</b>
*	823-3516	Fluecap, <b>SM260G</b>
*	823-3659	Fluecap, <b>SM280G</b>
18	824-0995	Wireway, Control Panel- <b>SM50G</b>
*	824-0993	Wireway, Control Panel- <b>SM60G</b>
*	824-1128	Wireway, Control Panel- <b>SM80G</b>
19	824-1025	Wireway, Control Panel- <b>SM220G</b>
*	824-1026	Wireway, Control Panel- <b>SM20G</b>
20	824-1029	Topcap- <b>SM20/20/50/50G</b>
*	824-1030	Topcap- <b>SM20/50/50/20G</b>
*	824-1028	Topcap- <b>SM20/20/50G</b>
*	824-1177	Topcap- <b>SM20/20/50G 3-Battery</b>
*	824-0999	Topcap- <b>SM250G</b>
*	824-1000	Topcap- <b>SM350G</b>
*	824-1001	Topcap- <b>SM450G</b>
*	210-2822	Topcap- <b>SM260G</b>
*	210-2824	Topcap- <b>SM360G</b>
*	210-2825	Topcap- <b>SM460G</b>
*	824-1009	Topcap- <b>SM280G</b>
*	824-1010	Topcap- <b>SM380G</b>
*	824-1011	Topcap- <b>SM480G</b>
*	210-5109	Joiner Strip- <b>SM22G</b>
*	210-3182	Joiner Strip- <b>SM50/60, SR62G</b>
*	210-1679	Joiner Strip- <b>SM220</b>
*	210-2681	Joiner Strip- <b>SR42</b>
*	KIT00092SP	Air Shutter Kit
<b>ACCESSORIES</b>		
*	803-0271	Basket, Fry ( <b>SM20, SM40, SM50, SR42 and SR52</b> )
*	803-0304	Basket, Fry ( <b>SM60 and SM80</b> )
*	803-0277	Screen, Fine Mesh <b>SR42 (Use 803-0149 for SR62, SM60)</b>
*	803-0280	Screen, Fine Mesh <b>SM80</b>
*	803-0273	Rack, Basket Support <b>SR42</b>
*	803-0327	Grid Assembly <b>SM20</b> Basket Rack
*	210-3911	Hanger, Basket <b>20/50/MC</b>
*	210-3368	Hanger, Basket <b>SM20 (Hooks over the Flue)</b>
*	210-1595	Hanger, Basket <b>SM35/40/50 SS 15½"</b>
*	200-1360	Hanger, Basket (Over flue style) <b>SR42/52 CR 15½"</b>
*	210-2737SP	Hanger, Basket <b>SR62/SM60/SM160G SS 20" (Hooks over Flue)</b>
*	810-2793	Hanger, Wire Basket Single <b>SR42/50</b>
*	810-2794	Hanger, Wire Basket Double <b>SR42/50/62</b>
*	106-2631SP	Tray Assembly, Sediment <b>SM60</b>
*	809-0171	Thumbscrew (Nut 826-1351 qty. 10)
*	106-1637SP	Frypot Cover <b>SR42/52, SM50</b>
*	106-1479SP	Frypot Cover <b>SM60</b>
*	106-2470	Frypot Cover <b>SM80</b>

\* Not Illustrated

# DEAN MILLIVOLT GAS FRYERS

## CHAPTER 2: PARTS LIST

### 2.3 Component Box Components and Related Components (CE and Domestic)\*

\* Components are applicable to all Millivolt fryers covered in this manual unless otherwise noted.

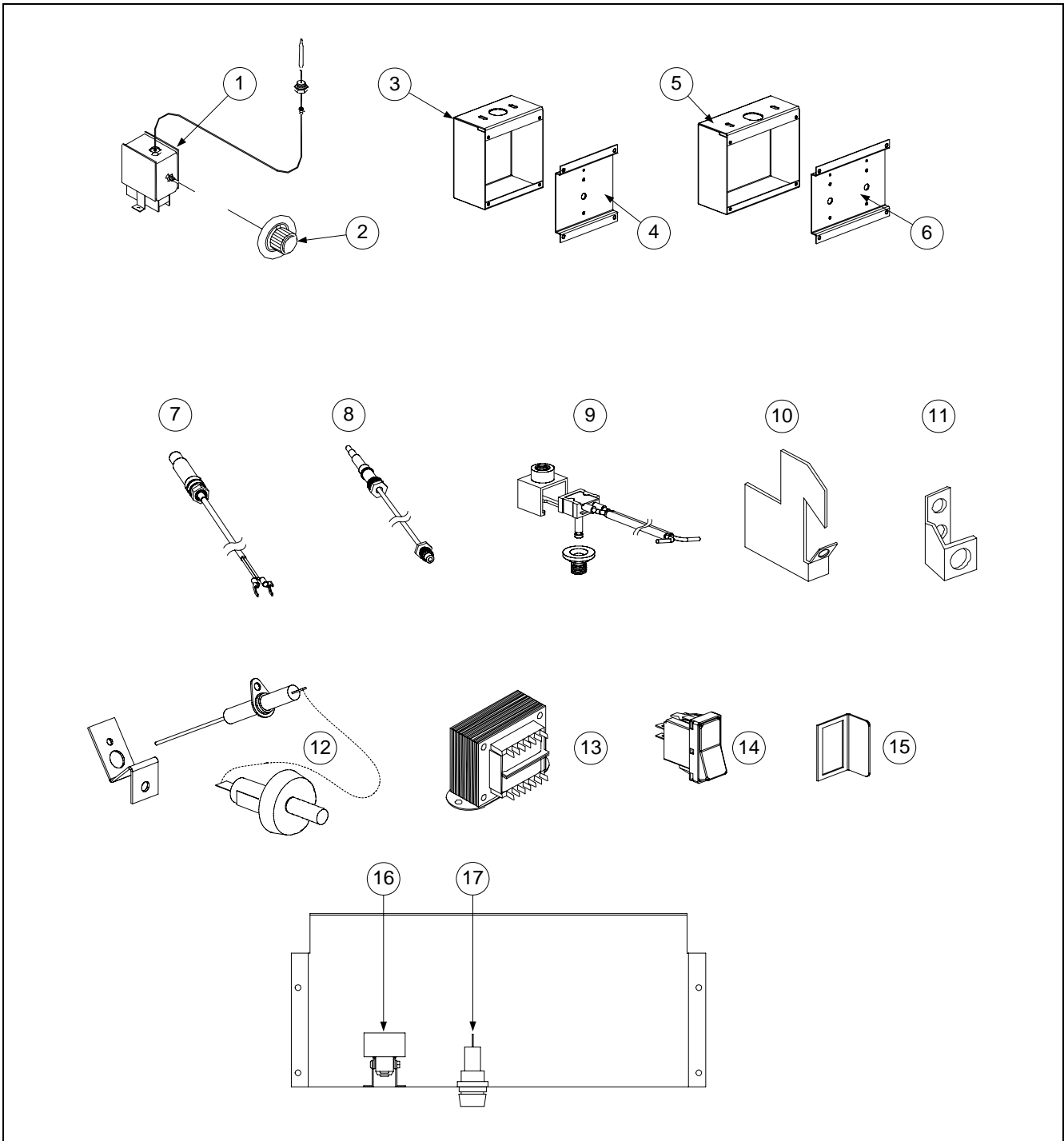

**DEAN MILLIVOLT GAS FRYERS  
CHAPTER 2: PARTS LIST**

**2.3 Component Box Components and Related Components (CE and Domestic- cont.)**

ITEM	PART #	COMPONENT
1	826-2013	Thermostat, Sunne <i>(Use 807-1692 for CE)</i>
*	810-2047	Spring, Spacer- Thermostat Capillary Bulb
*	210-1302	Clamp, Thermostat/High Limit Capillary Bulb <i>(Use 210-1433 for 2 hole)</i>
*	200-1320	Mounting Bracket, Thermostat & High-Limit
2	810-2035	Knob, Thermostat <i>(Use 816-0139 for CE)</i>
3	200-1618	Box, Thermostat- Single
4	200-3217	Cover, Thermostat Box- Single
5	200-3277	Box, Thermostat- Dual <i>(Used in 20/50 Combination Systems)</i>
6	200-3906	Cover, Thermostat Box- Dual <i>(Used in 20/50 Combination Systems)</i>
7	810-2033	Thermopile <i>(Use 807-3565 for CE)</i>
8	810-1152	Thermocouple <b>(CE ONLY)</b> <i>(Use 812-1284 for Assembly)</i>
9	106-1768SP	ECO Connector (Honeywell Valves Only- <b>CE ONLY</b> )
*	106-1879	ECO Connector (Robertshaw Valves Only- <b>CE ONLY</b> )
10	200-5479	Bracket, Pilot Thermocouple
11	810-2401	Bracket, Thermopile
12	810-1001	Piezo Ignitor (Trigger) <i>(Wire Lead-807-3650) (Assembly-44970SP)</i>
*	200-1868	Piezo Bracket
*	807-3540	Electrode, Piezo CE <i>(Use 812-1532 for modified Electrode)</i>
13	807-1999	Transformer, Dual Voltage CE- Filtration System <b>(CE ONLY)</b>
*	807-0800	Transformer, 120/24 VAC- Filtration System
14	807-3580	Switch, Rocker- Manual Filter Power
15	210-2786	Guard, Switch (Optional- For Item 10)
16	807-3516	High-Limit Thermostat- Automatic Reset 435° F SM20/35,SR40/42
*	807-3560	High-Limit Thermostat- Manual Reset 410° F <b>(CE)</b>
*	807-3680	High-Limit Thermostat- Manual Reset 450° F
*	810-2046	Spring, Spacer- High Limit Capillary Bulb
17	807-1321	Fuse Holder, Buss
*	2747	Fuse Holder, Slot-head—Safety <b>(CE ONLY)</b>
*	807-3592	Fuse 2A Slow-Blow (230V Systems)
*	807-3750	Fuse 5A (120V Systems)

\* Not Illustrated

# DEAN MILLIVOLT GAS FRYERS

## CHAPTER 2: PARTS LIST

### 2.4 Frypot and Burner System Components

#### 2.4.1 SM220 and SM20/20/~ Systems

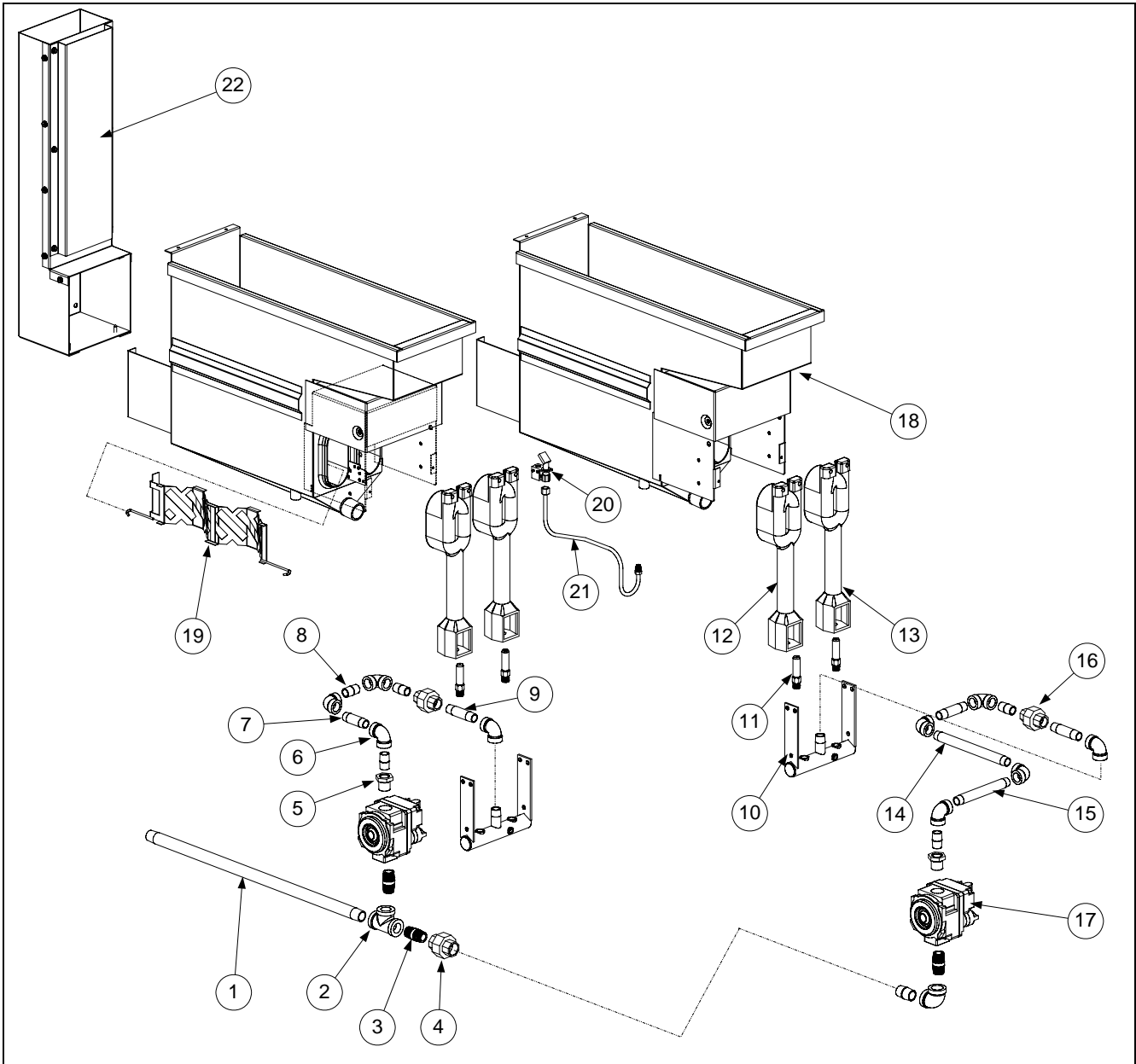

ITEM	PART #	COMPONENT
1	813-0737	Nipple, ½" NPT x 21" BM
*	810-2043	Clamp, Pipe- ½" BM Pipe
*	809-0805	Bolt, Pipe Clamp- ¼" -20 x ½" Hex
*	200-1450	Bracket, Gas-Supply Clamp Support (UFF-Equipped Systems)

\* Not Illustrated

**DEAN MILLIVOLT GAS FRYERS  
CHAPTER 2: PARTS LIST**

**2.4.1 SM220 and SM20/20/~ Systems (cont.)**

ITEM	PART #	COMPONENT
2	813-0003	Tee, ½" NPT BM
3	813-0087	Nipple, ½" NPT x 1-½" BM
4	813-0173	Union, ½" NPT BM
5	813-0780	Bushing, ⅜" NPT x ½" BM
6	813-0631	Elbow, ⅜" NPT 90° BM
7	813-0676	Nipple, ⅜" NPT x 2" BM
8	813-0625	Nipple, ⅜" NPT x Close BM
9	813-0649	Nipple, ⅜" NPT x 2-½" BM
10	810-2352	Manifold, Gas- <b>SM20G</b>
*	200-1615	Bracket, Manifold Mounting
11	810-2050	Orifice, Natural- #44 (2.18 mm)- <b>Domestic/International</b>
*	810-0710	Orifice, LP- #54 (1.40 mm)- <b>Domestic/International</b>
*	810-2060	Orifice, G20-G25- (2.40 mm)- <b>CE Only</b>
*	810-2059	Orifice, G31- (1.51 mm)- <b>CE Only</b>
12	810-2151	Burner, Left
13	810-2150	Burner, Right
*	200-1374	Bracket, Burner Mounting- <b>SM20G</b>
*	200-1331	Shield, Burner Heat- <b>SM20G</b>
14	813-0668	Nipple, ⅜" NPT x 7" BM
15	813-0782	Nipple, ⅜" NPT x 5" BM
16	813-0781	Union, ⅜" NPT BM
17	807-3645	Valve, Gas- Natural (Robertshaw MV) ½" in x ¾" out
*	807-1603	Valve, Gas- Natural Honeywell ½" in x ½" out
*	810-2036	Valve, Gas- Natural Honeywell ½" in x ¾" out
*	807-2122	Valve, Gas- Natural <b>CE</b> Honeywell
*	810-2399	Valve, Gas- Propane (Robertshaw MV)
*	807-1604	Valve, Gas- Propane Honeywell
*	807-2121	Valve, Gas- Propane <b>CE</b> Honeywell
*	810-0975	Knob, Gas Valve Honeywell
*	810-0691	Vent Tube 4" (Use 810-1166 for <b>CE</b> 3.86")
18	826-1874	Frypot Assembly- <b>SM20G</b> - M/S <i>obsolete use 826-1875</i>
*	826-1875	Frypot Assembly- <b>SM20G</b> - S/S
19	200-5175	Diffuser, Burner-Tube- <b>SM20G</b>
20	810-2158	Pilot Burner- <b>SM20G</b> - Natural(0.18 Orifice) ( <b>Use 810-2526 for LP</b> )
*	810-2689	Pilot Assembly Honeywell w/ Piezo- Natural ( <b>Use 810-2690 for LP</b> )
*	106-4968	Pilot Assembly w/ Piezo-Natural <b>SM20G</b>
21	810-0703	Gas Line, Pilot Supply- ¼" x 17-½" (CE -810-1172 - ¼" x 22")
*	810-2602	Gas Line, Pilot Supply- ¼" x 25"
22	106-1583SP	<b>Flue Assembly- SM20G</b>
*	200-1342	Shield, Flue Heat- <b>SM20G</b>
*	200-1344	Front, Flue Box- <b>SM20G</b>
*	200-1351	Rear, Flue Box- <b>SM20G</b>
*	200-3081	Air Shutter (Use KIT00092SP for Air Shutter Kit)

\* Not Illustrated

SM 20 series began using Honeywell gas valves in July 2003.



# DEAN MILLIVOLT GAS FRYERS

## CHAPTER 2: PARTS LIST

### 2.4.2 SR Series, SM35G, SM40G and SM50G Systems

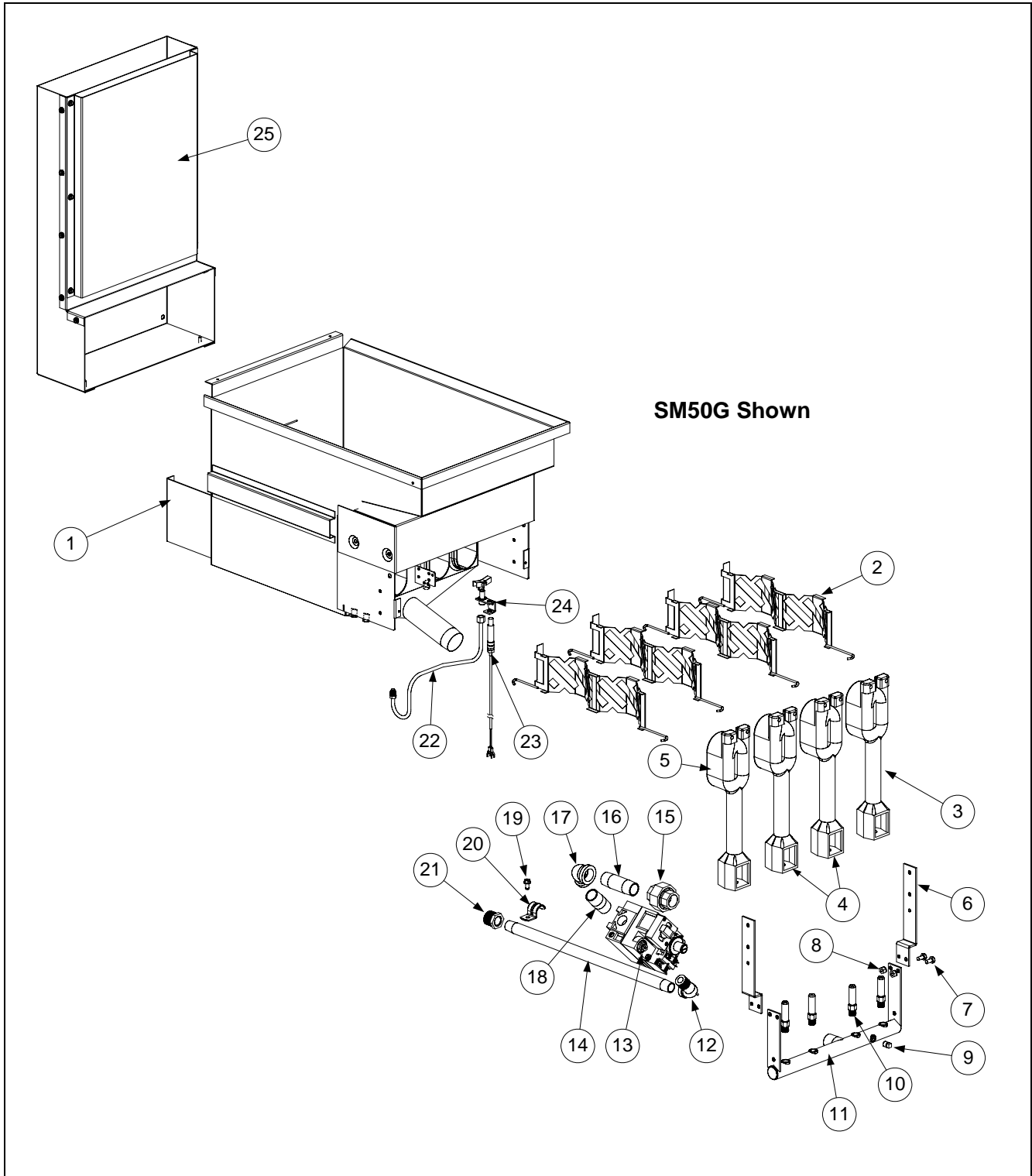

**DEAN MILLIVOLT GAS FRYERS  
CHAPTER 2: PARTS LIST**

**2.4.2 SR Series, SM35G, SM40G and SM50G Systems (cont.)**

ITEM	PART #	COMPONENT
1	12188-1	Frypot- M/S (After 6/98)- <b>SR38G</b> <i>obsolete</i>
*	12188-2	Frypot- S/S (After 6/98)- <b>SR38G</b> <i>obsolete</i>
*	12082NV	Frypot- M/S (P&S Prior to 6/98)- <b>SR38G</b> <i>obsolete</i>
*	12202-1	Frypot- M/S (Japan/Singapore)- <b>SR38G</b> <i>obsolete</i>
*	12202-2	Frypot- S/S (Japan/Singapore)- <b>SR38G</b> <i>obsolete</i>
*	826-1865	Frypot- S/S- <b>SR42G</b> ( <i>Began using 1" drain Mar. 2003</i> )
*	826-1871	Frypot- S/S- <b>SR52G, SM50G</b>
*	826-1867	Frypot- S/S- <b>SM35G, SM40G</b>
2	210-5185	Diffuser, Burner Tube- <b>SR38G, SR42G, SM35G, SM40G</b>
*	210-5175	Diffuser, Burner Tube- <b>SM50G</b>
*	210-5216	Diffuser, Burner Tube- <b>SR52G</b>
3	810-2150	Burner, Right- <b>SR52G, SM50G</b>
*	810-2039	Burner, Right- <b>SR38G, SR42G, SM35G, SM40G</b>
4	810-2149	Burner, Center- <b>SR52G, SM50G</b>
*	810-2038	Burner, Center- <b>SR38G, SR42G, SM35G, SM40G</b>
5	810-2151	Burner, Left- <b>SR52G, SM50G</b>
*	810-2037	Burner, Left- <b>SR38G, SR42G, SM35G, SM40G</b>
*	200-1329	Bracket, Burner Mounting- <b>SR52G, SM50G</b>
*	809-0459	Bolts, Burner <sup>5</sup> / <sub>16</sub> " – 18x <sup>3</sup> / <sub>4</sub> " Hex Head Washer
*	823-3600	Support Assembly, Burner- <b>SM35G, SM40G</b> ( <u>Includes Burner Mounting Bracket &amp; Heat Shield</u> )
*	200-1129	Shield, Burner Heat- <b>SR42G</b> <i>not used after 12/10/04</i>
*	200-1330	Shield, Burner Heat- <b>SR52G, SM50</b> and <b>200-1331</b>
6	200-1615	Bracket, Manifold Mounting- <b>SR52G, SM50G</b>
*	200-1311	Bracket, Manifold Mounting- <b>SR38G, SR42G</b>
7	809-0428	Bolt, <sup>1</sup> / <sub>4</sub> " -20 x <sup>1</sup> / <sub>2</sub> " Hex Head
8	809-0823	Nut, Nylock- <sup>1</sup> / <sub>4</sub> " -20
9	813-0705	Plug, Brass- <sup>1</sup> / <sub>8</sub> " Square Head
10		<b>Orifice- Domestic/International</b>
*	810-2048	Orifice, Natural- #39 (2.53 mm)- <b>SR52G, SM50G,</b>
*	810-2132	Orifice, Natural- #37 (2.64 mm)- <b>SR38G</b>
*	810-2040	Orifice, Natural- #35 (2.80 mm)- <b>SR42G, SM35G, SM40G</b>
*	810-3097	Orifice, Natural- #35 (2.80 mm) .125-18 NPT - <b>SR42G built after 4/07</b>
*	810-2497	Orifice, LP- #55 (1.32 mm)- <b>SR52G, SR62G, SM20G, SM50G</b>
*	810-2059	Orifice, LP- #53 (1.51 mm)- <b>SR52G, SM50G,</b>
*	810-3102	Orifice, LP- #53 (1.51 mm) .125-18 NPT - <b>SR42 built after 4/07</b>
*	810-2063	Orifice, LP- #52 (1.61 mm)- <b>SR38G, SR62 (Australia)</b>
*	810-2064	Orifice, LP- #51 (1.70 mm)- <b>SR42G, SM35G, SM40G</b>
*	810-3099	Orifice, LP- #51 (1.70 mm), .125-18 NPT - <b>SR42G built after 4/07</b>
*	810-2400	Orifice, LP- #16 (.016)- Pilot <b>SR52</b>
*		<b>Orifice- CE Only</b>
*	810-2060	Orifice, G20-G25- (2.40 mm)- <u>All Millivolt Fryers in This Section</u>
*	810-3101	Orifice, G20-G25- (2.40 mm) .125-18 NPT - <b>SR42 built after 4/07</b>
*	810-2059	Orifice, G31- (1.51 mm)- <u>All Millivolt Fryers in This Section</u>
*	810-3102	Orifice, G31- (1.51 mm) .125-18 NPT- <b>SR42 built after 4/07</b>
11	823-3618	Manifold, Gas- <b>SR52G, SM50G</b>
*	810-2034	Manifold, Gas- <b>SR38G, SR42G</b>
*	810-3006	Manifold, Gas- <b>SR42G built after 4/07</b>
*	823-3619	Manifold, Gas- <b>SM35G, SM40G</b>

\* Not Illustrated

## DEAN MILLIVOLT GAS FRYERS CHAPTER 2: PARTS LIST

### 2.4.2 SR Series, SM35G, SM40G and SM50G Systems (cont.)

ITEM	PART #	COMPONENT
		<b>Gas Valve and Related Plumbing- SM50G – Plumbing Will Vary From Model to Model- Use the Following Parts As A Reference When Obtaining Parts For Systems in This Section Other Than SM50G</b>
12	813-0165	Elbow, Street- ½" NPT 90° BM
13	810-2036	Valve, Gas- Natural, Honeywell- <b>Domestic/International</b> ½" in x ¾" out
*	807-1603	Valve, Gas- Natural, Honeywell- ½" in x ½" out Started using Feb. 2003
*	807-3648	Valve, Gas- Natural, Honeywell- ¾" in x ¾" out Started using Feb. 2003 Export
*	807-3645	Valve, Gas- Natural, Robertshaw- ½" in x ¾" out
*	807-3549	Valve, Gas- LP, Honeywell- <b>Domestic/International</b>
*	807-1604	Valve, Gas- LP, Honeywell- ½" in x ½" out Started using Feb. 2003
*	807-3553	Valve, Gas- LP, Honeywell- ¾" in x ¾" out
*	810-1155	CE Adaptor Kit, Honeywell Valve
*	807-2122	Valve, Gas- Natural, Honeywell- <b>CE Only</b>
*	807-2121	Valve, Gas- LP, Honeywell- <b>CE Only</b>
*	807-4137	Valve, Gas- Natural, Honeywell- <b>Australia</b>
*	807-4138	Valve, Gas- LP, Honeywell- <b>Australia</b>
*	807-1846	Valve, Kit – Natural to Propane Conversion
14	813-0418	Nipple, ½" NPT x 17" BM- <b>SM50G</b>
*	813-0670	Nipple, ½" NPT x 19" BM ( <u>Measure To Confirm Length</u> )
*	813-0585	Nipple, ½" NPT x 20-½" BM ( <u>Measure To Confirm Length</u> )
*	813-0737	Nipple, ½" NPT x 21" BM ( <u>Measure To Confirm Length</u> )
15	813-0174	Union- ¾" NPT BM
16	813-0254	Nipple, ¾" NPT x 3" BM- <b>SM50G</b>
17	813-0066	Elbow- ¾" NPT 90° BM
18	813-0112	Nipple, ¾" NPT x 2" BM- <b>SM50G</b>
19	809-0805	Bolt, ¼"-20 x ½" Hex Head
20	810-2043	Clamp, Pipe- ½"
*	200-1450	Bracket, Gas-Supply Clamp Support (UFF-Equipped Systems)
21	813-0031	Bushing, ¾" NPT x ½" NPT BM
22	810-0703	Gas Line, Pilot Supply- ¼" x 17-½" (For <b>CE</b> use 810-1172 <b>23"</b> or 810-2602 <b>25"</b> )
23	810-2033	Thermopile- Non-CE
*	807-3565	Thermopile- <b>CE Only</b> ( Thermocouple 810-1152)
24	810-2032	Burner, Pilot- Natural (Use 106-0692SP for Assembly. Includes item 22, 23 and 24)
*	810-2155	Burner, Pilot- LP
25	106-1742SP	<b>Flue Assembly- SR52G, SM50G</b>
*	200-2872	Shield, Flue Heat- <b>SR52G, SM50G</b>
*	200-1343	Front, Flue Box- <b>SR52G, SM50G</b>
*	200-1350	Rear, Flue Box- <b>SR52G, SM50G</b>
*	12203	<b>Flue Assembly- SR38G</b>
*	12-0363	Shield, Flue Heat- <b>SR38G obsolete</b>
*	12-0362	Front, Flue Box- <b>SR38G obsolete</b>
*	12-0361	Rear, Flue Box- <b>SR38G obsolete</b>
*	106-0696SP	<b>Flue Assembly- SR42G</b>
*	200-1304	Front, Flue Box- <b>SR42G</b>
*	200-1303	Rear, Flue Box- <b>SR42G</b>
*	106-0954SP	<b>Flue Assembly- SM35G, SM40G</b>
*	200-1690	Shield, Flue Heat- <b>SM35G</b>
*	200-1701	Front, Flue Box- <b>SM35G</b>
*	200-1678	Rear, Flue Box- <b>SM35G</b>
*	449-41001	Garland SM50 Drop In Assembly- Natural
*	449-4100001	Garland SM50 Drop In Assembly- Propane

\* Not Illustrated

# DEAN MILLIVOLT GAS FRYERS

## CHAPTER 2: PARTS LIST

### 2.4.3 SR62, SM60G and SM80G Systems

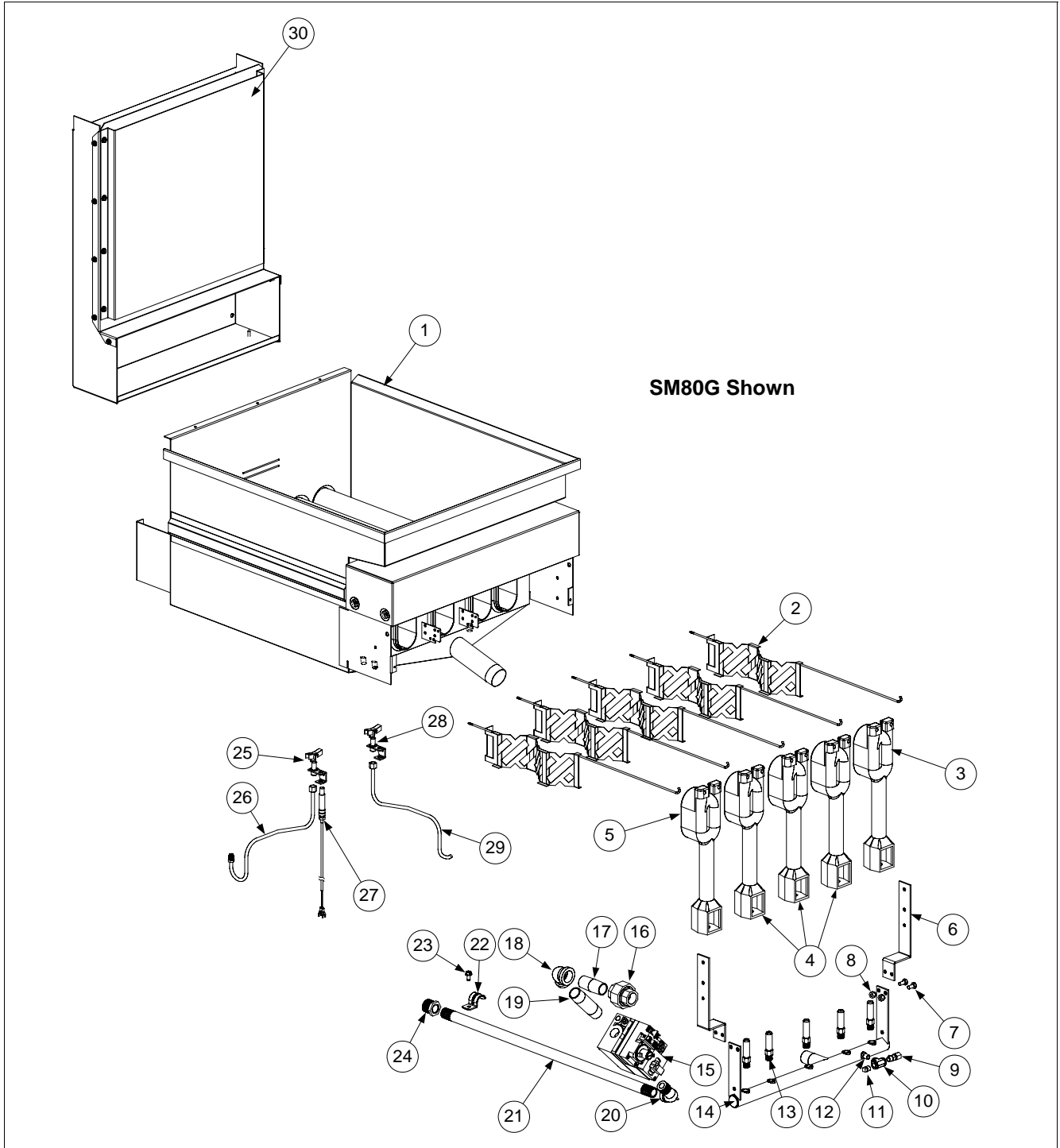

**DEAN MILLIVOLT GAS FRYERS  
CHAPTER 2: PARTS LIST**

**2.4.3 SR62, SM60G and SM80G Systems (cont.)**

ITEM	PART #	COMPONENT
1	823-3506SP	Frypot- M/S- <b>SM80G (After 10/99)</b> <i>obsolete use 823-3494SP</i>
*	823-3494SP	Frypot- S/S- <b>SM80G (After 10/99)</b> 1¼" (Use 823-3396SP for 1 ½")
*	20004-3SK	Frypot- M/S- <b>SM80G (Prior To 10/99)</b> <i>obsolete use 826-1891</i>
*	826-1891	Frypot- S/S- <b>SM80G (Prior To 10/99)</b>
*	826-1819	Frypot- M/S- <b>SM60G</b> <i>obsolete use 826-1802</i>
*	826-1802	Frypot- S/S- <b>SM60G, SR62G (Use 823-3511SP for SM160G)</b>
2	823-3404	Diffuser, Burner Tube- <b>SM80G</b>
*	210-5215	Diffuser, Burner Tube- <b>SM60G, SR62G</b>
3	810-2150	Burner, Right- <b>SM60G, SM80G, SR62G</b>
4	810-2149	Burner, Center- <b>SM60G, SM80G, SR62G</b>
5	810-2151	Burner, Left- <b>SM60G, SM80G, SR62G</b>
*	200-2734	Bracket, Burner Mounting- <b>SM80G</b>
*	200-2738	Bracket, Burner Mounting- <b>SM60G, SR62G</b>
*	200-2707	Shield, Burner Heat- <b>SM80G</b>
*	200-2746	Shield, Burner Heat- <b>SM60G, SR62G</b>
6	200-1314	Bracket, Manifold Mounting- <b>SM80G</b>
*	200-1615	Bracket, Manifold Mounting- <b>SM60G, SR62G</b>
7	809-0428	Bolt, ¼"-20 x ½" Hex Head
8	809-0823	Nut, Nylock- ¼"-20
9	810-2138	Valve, Trailing Pilot- <b>SM60G, SM80G, SR62G</b> adjustment valve
10	813-0642	Tee, ⅛" NPT
11	813-0705	Plug, Brass- ⅛" Square Head
12	813-0643	Nipple, ⅛" NPT x Close BM
13		<b>Orifice- Domestic/International</b>
*	810-2062	Orifice, Natural- #38 (2.58 mm)- <b>SM80G</b>
*	810-2048	Orifice, Natural- #39 (2.53 mm)- <b>SM60G, SR62G</b>
*	810-2063	Orifice, LP- #52 (1.61 mm)- <b>SM80G, SR62G (Australia)</b>
*	810-2059	Orifice, LP- #53 (1.51 mm)- <b>SM60G, SR62G</b>
*		<b>Orifice- CE Only</b>
*	810-2060	Orifice, G20-G25- (2.40 mm)- <u>All Millivolt Fryers in This Section</u>
*	810-2059	Orifice, G31- (1.51 mm)- <u>All Millivolt Fryers in This Section</u>
14	823-3617	Manifold, Gas- <b>SM60G, SM80G, SR62G</b>
15	810-2036	Valve, Gas- Natural, Honeywell- <b>Domestic/Intl</b> ½" in x ¾" out
*	807-2122	Valve, Gas- Natural, Honeywell- <b>CE Only</b>
*	807-3648	Valve, Gas- Natural and MFG, Honeywell ¾" in x ¾" out (Export)
*	807-3645	Valve, Gas- Natural, Robertshaw MV ½" in x ¾" out
*	807-3549	Valve, Gas- LP, Honeywell- <b>Domestic/Intl</b>
*	807-2121	Valve, Gas- LP, Honeywell- <b>CE Only</b>
*	810-2399	Valve, Gas- LP, Robertshaw MV
16	813-0174	Union- ¾" NPT BM
17	813-0635	Nipple, ¾" NPT x 2-½" BM
18	813-0066	Elbow- ¾" NPT 90° BM
19	813-0743	Nipple, ¾" NPT x 3-½" BM
20	813-0165	Elbow, Street- ½" NPT 90° BM
21	813-0670	Nipple, ½" NPT x 19" BM ( <u>Measure To Confirm Length</u> )
*	813-0585	Nipple, ½" NPT x 20-½" BM ( <u>Measure To Confirm Length</u> )
*	813-0737	Nipple, ½" NPT x 21" BM ( <u>Measure To Confirm Length</u> )

\* Not Illustrated

**DEAN MILLIVOLT GAS FRYERS  
CHAPTER 2: PARTS LIST**

**2.4.3 SR62, SM60G and SM80G Systems (cont.)**

ITEM	PART #	COMPONENT
22	810-2043	Clamp, Pipe- ½"
23	809-0805	Bolt, Pipe Clamp- ¼"-20 x ½" Hex
*	200-1450	Bracket, Gas-Supply Clamp Support (UFF-Equipped Systems)
24	813-0031	Bushing, ¾" NPT x ½" NPT BM
25	810-2032	Burner, Pilot- Natural ( <i>Use 106-0692SP for Assembly</i> )
*	810-2155	Burner, Pilot- LP ( <i>Use 106-1696SP for Assembly</i> )
26	810-0703	Gas Line, Main Pilot Supply- ¼" x 17-½"
*	810-1172	Gas Line, Pilot Supply- ¼" x 23" <b>CE</b>
*	810-2602	Gas Line, Pilot Supply- ¼" x 25" <b>CE</b>
27	810-2033	Thermopile- Non-CE
*	807-3565	Thermopile- <b>CE Only</b>
28	810-2032	Burner, Pilot- Natural & MFG (Also Used For Main Pilot)
*	106-0692	Burner, Pilot Assembly- Natural & MFG
*	810-2155	Burner, Pilot- LP (Also Used For Main Pilot)
29	812-0703	Gas Line, Trailing Pilot Supply- ¼" x 17-½" (Cut To Length)
30	106-1442SP	<b>Flue Assembly- SM80G</b>
*	200-1316	Shield, Flue Heat- <b>SM80G</b>
*	200-1347	Front, Flue Box- <b>SM80G</b>
*	200-1349	Rear, Flue Box- <b>SM80G</b>
*	106-0997SP	<b>Flue Assembly- SM60G, SR62G</b>
*	200-1325	Shield, Flue Heat- <b>SM60G, SR62G</b>
*	200-1339	Front, Flue Box- <b>SM60G, SR62G</b>
*	200-1773	Rear, Flue Box- <b>SM60G, SR62G</b>

\* Not Illustrated

# DEAN MILLIVOLT GAS FRYERS

## CHAPTER 2: PARTS LIST

### 2.5 Oil Drain Manifold Components

#### 2.5.1 1½" Oil Drain Manifold, Drain Flush and Drain Valve Components\*

\*Typical components illustrated below. Components will vary according to system.

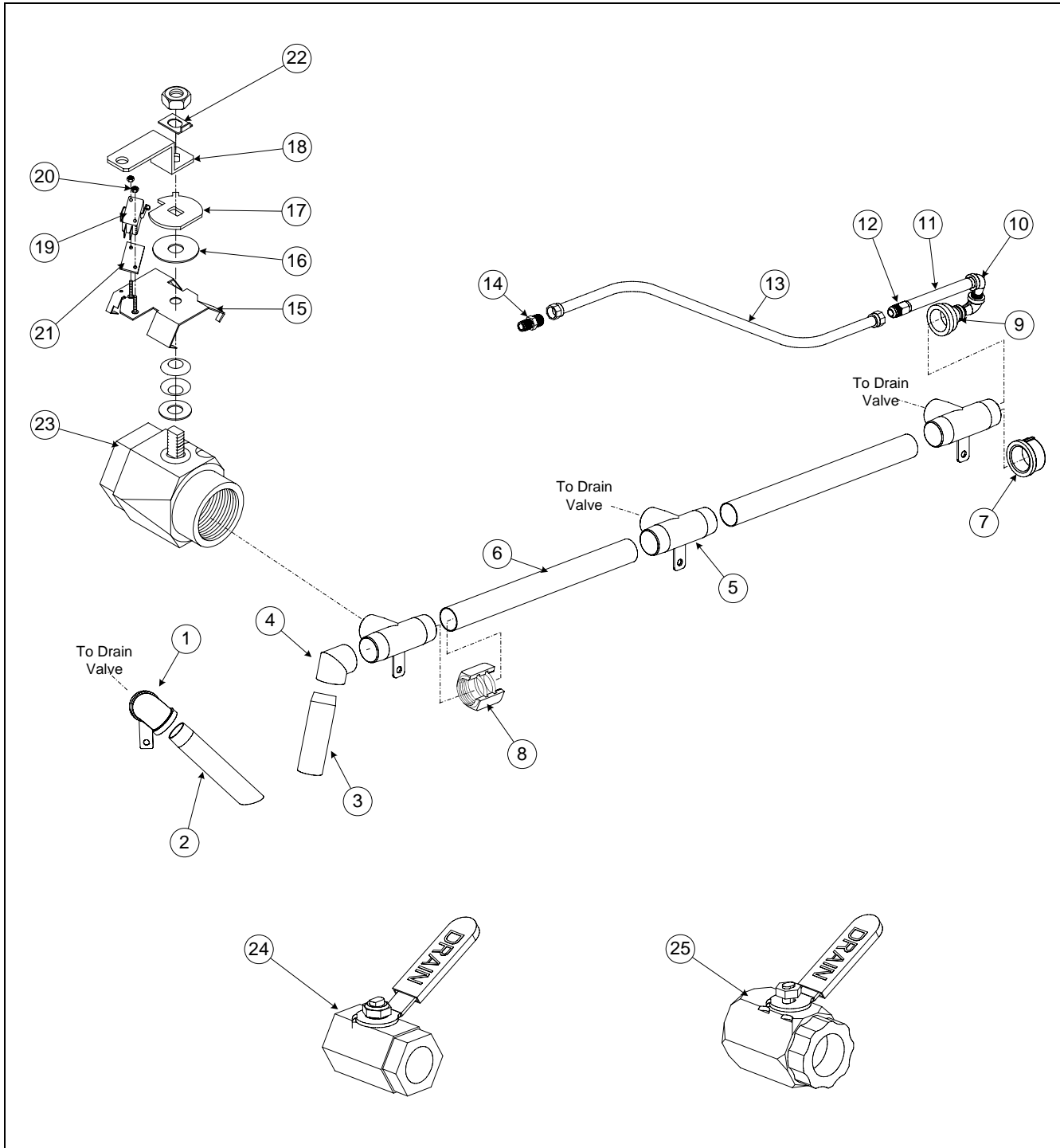

**DEAN MILLIVOLT GAS FRYERS  
CHAPTER 2: PARTS LIST**

**2.5.1 Oil Drain Manifold, Drain Flush and Drain Valve Components (cont.)**

ITEM	PART #	COMPONENT
1	823-3565	Elbow, with Bracket (LH)- 1-¼"- UFF 50
*	823-3566	Elbow, with Bracket (RH)- 1-¼"- UFF 50
2	812-1524	Drain Pipe, Left Side (Use 823-3418 for Chili's)
3	813-0784	Drain Pipe, Right Side 1 ½" x 6"
4	813-0829	Elbow, 1-½" NPT 75°
5	813-0748	Tee, 1-½" NPT x 1-¼" BM With Handle Bracket
6	200-1827	Drain Manifold Tube- 1-½" x 13-¼"
7	813-0659	Pipe Cap, 1-½"
8	809-0884	Nut, Slip Joint- 1-½"
*	816-0544	O-ring (Slip-Joint Nut)
9	813-0686	Bell Reducer, ½" NPT x 1-½"
10	813-0165	Elbow, Street- ½" NPT 90°
11	813-0672	Nipple, ½" NPT x 8" BM
12	810-1669	Adapter, ⅝" O.D. x ½"- Female
13	810-1069	Flex Line, ⅝" x 29-½ "
14	810-1668	Adapter, ⅝" O.D. x ½"- Male
<b>Drain Valve Components</b>		
15	106-1401	Bracket, Microswitch (Optional On SUFF/UFF Units)
16	200-1617	Washer, Drain Valve (Use Without Microswitch)
17	210-2029	Bracket, Activator- Microswitch (Also Used On Valves Without Microswitch As A Handle-Stop)
18	210-4727	Handle (Actuator), Drain Valve
*	823-3440	Handle, Push/Pull- Drain (With Cap)
*	809-0885	Washer, ⅜" x 1" x .083"
*	809-0843	Pin, Cotter
*	816-0547	Cap, Vinyl-Red
19	807-2104	Microswitch (Optional On SUFF/UFF Units)
20	809-0842	Nut, Nylock- #4-40 (Microswitch To Bracket)
21	816-0220	Insulation, Microswitch
22	200-1257	Retainer, Nut
23	810-2127	Drain Valve, 1-½" Full Port (With Washers & Nut)
24	810-2052	Drain Valve, 1-¼" (1" Standard Port)
*	810-2442	Handle, Valve Lever
*	810-1338	Drain Valve, 1" <b>SM20G, SR42G</b> <i>see note below</i>
*	210-3902	Handle, Valve Lever ( <b>For 810-1338 Only</b> )- <b>SM20G</b>
*	106-1417SP	Drain Valve Assembly 1" RH and LH
*	813-0138	Nipple, 1" NPT x Close (To Adapt To 1-¼" Extended Drain Nipple)
*	813-0716	Bushing, 1" NPT x 1-¼" BM (To Adapt To 1-¼" Extended Drain Nipple)
*	813-0406	Coupling, 1-¼" NPT x 2" (To Adapt To 1-¼" Extended Drain Nipple)
25	810-2126	Drain Valve, 1-¼" Full-Port (Use 106-2439 for Assembly)
*	812-1226SP	Nipple, Drain- 1-¼" Painted- <b>SM Series Fryers (use 813-0276 for SM20)</b>
*	813-0392	Nipple, Drain- 1-¼" NPT x 8" BM- <b>All SR Series Fryers except SR42 w/ 1"</b>
*	812-1681	Nipple, Drain- 1-¼" x 5" NPT
*	813-0870	Nipple, Drain- 1-¼" x 10" NPT
*	813-0669	Nipple, Drain- 1" x 8" (Use 812-1668 for 5"- <b>SR42</b> ) (Use 813-0605 for 9"- <b>SR62</b> )

\* Not Illustrated

Note: In Mar. 2003 SR42G went to 1" drain valves.



# DEAN MILLIVOLT GAS FRYERS

## CHAPTER 2: PARTS LIST

### 2.5.2 3" Oil Drain Manifold, Drain Flush and Drain Valve Components

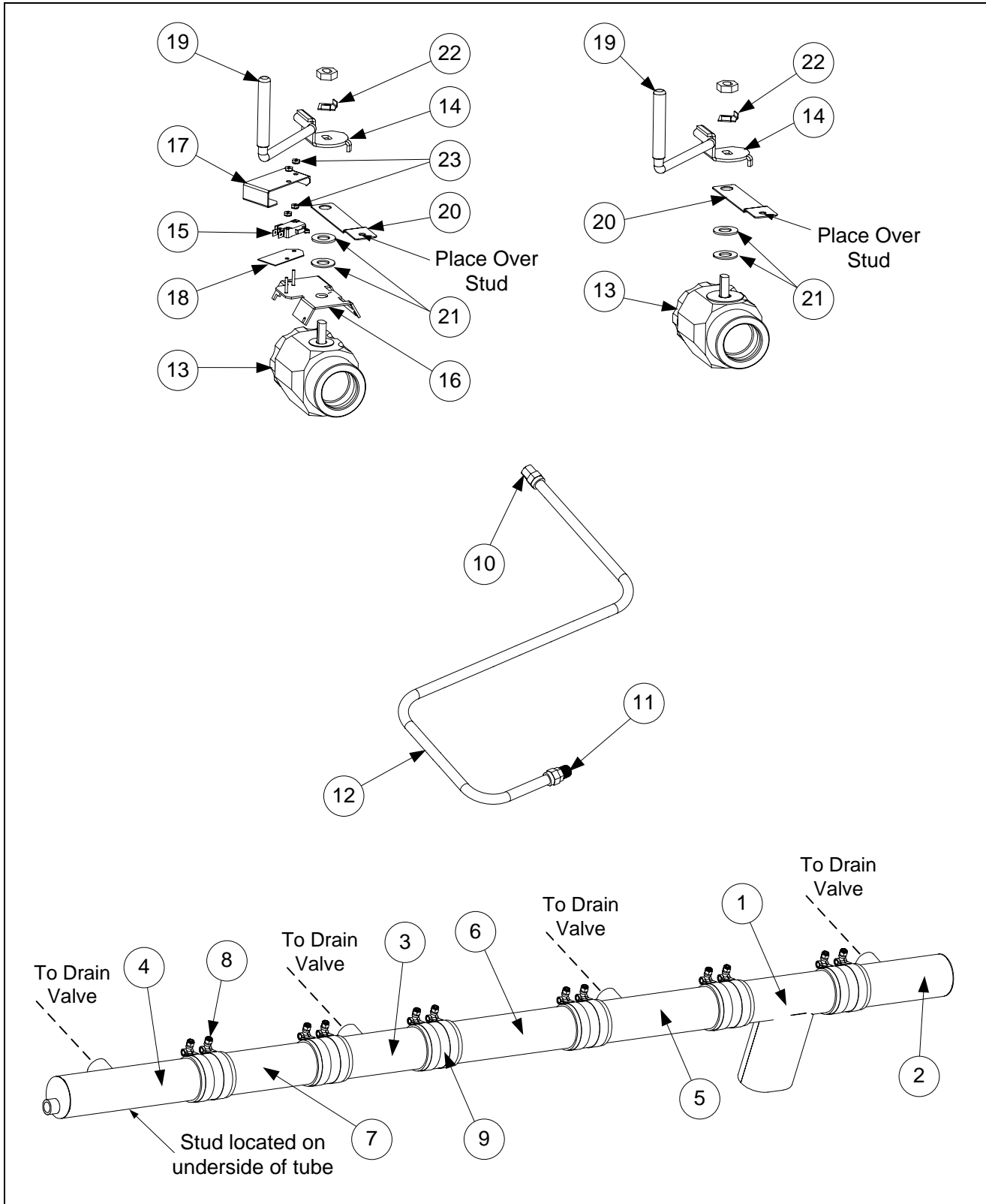

**DEAN MILLIVOLT GAS FRYERS  
CHAPTER 2: PARTS LIST**

**2.5.2 3" Oil Drain Manifold, Drain Flush & Drain Valve Components (cont.)**

<b>ITEM</b>	<b>PART #</b>	<b>COMPONENT</b>
1	823-4712	Tube, 3" Oval Dump
2	823-4681	Tube, 3" Right Drain (closed end)
3	823-4682	Tube, 3" Center Drain (open ends)
4	823-4844	Tube, 3" Left Drain (closed end)
5	823-5188	Tube, 3" Right Filter (open ends)
6	200-6603	Tube, 3" Joiner (11.5")
7	200-9365	Tube, 3" Joiner (8.63")
8	809-0969	Clamp, T-bolt
9	816-0625	Boot/Sleeve
	106-1726	<b>Flush Oil Drain Line</b>
10	810-1669	Adapter, Female 5/8" O.D. x 1/2" long
11	810-1668	Adapter, Male 5/8" O.D. x 1/2" long
12	810-1056	Flexline, 5/8" O.D. x 52.5" long
	106-3976	<b>Drain Valve Assembly, 1 1/2" Without Microswitch</b>
	106-3977	<b>Drain Valve Assembly, 1 1/2" With Microswitch</b>
13	810-2783	Drain Valve, 1 1/2" Full Port with O-ring
14	823-4734	Handle, Drain Valve Rotating
15	807-2104	Microswitch, CE Micro-roller Lever
16	106-1401	Microswitch Bracket Assembly
17	200-4402	Guard, Drain Microswitch
18	816-0220	Insulation, RF Switch
19	816-0547	Cap, Red Vinyl for Handle
20	200-6116	Strap, 1 1/2" (holds tube to valve via the stud)
21	200-1617	Washer, Drain Microswitch
22	200-1257	Retainer, Drain Valve
23	826-1366	Nut, 4-40 Keps Hex w/ External Teeth (Pkg. of 25)
*	816-0630	Cap, Vinyl (one per clamp, covers T-bolt threads)

\* Not Illustrated

**DEAN MILLIVOLT GAS FRYERS  
CHAPTER 2: PARTS LIST**

## 2.6 Oil Return Manifold Components

### 2.6.1 Oil Return Manifold Components; Fryers with 1½" Drains\*

\*Typical components illustrated below. Components will vary according to system.

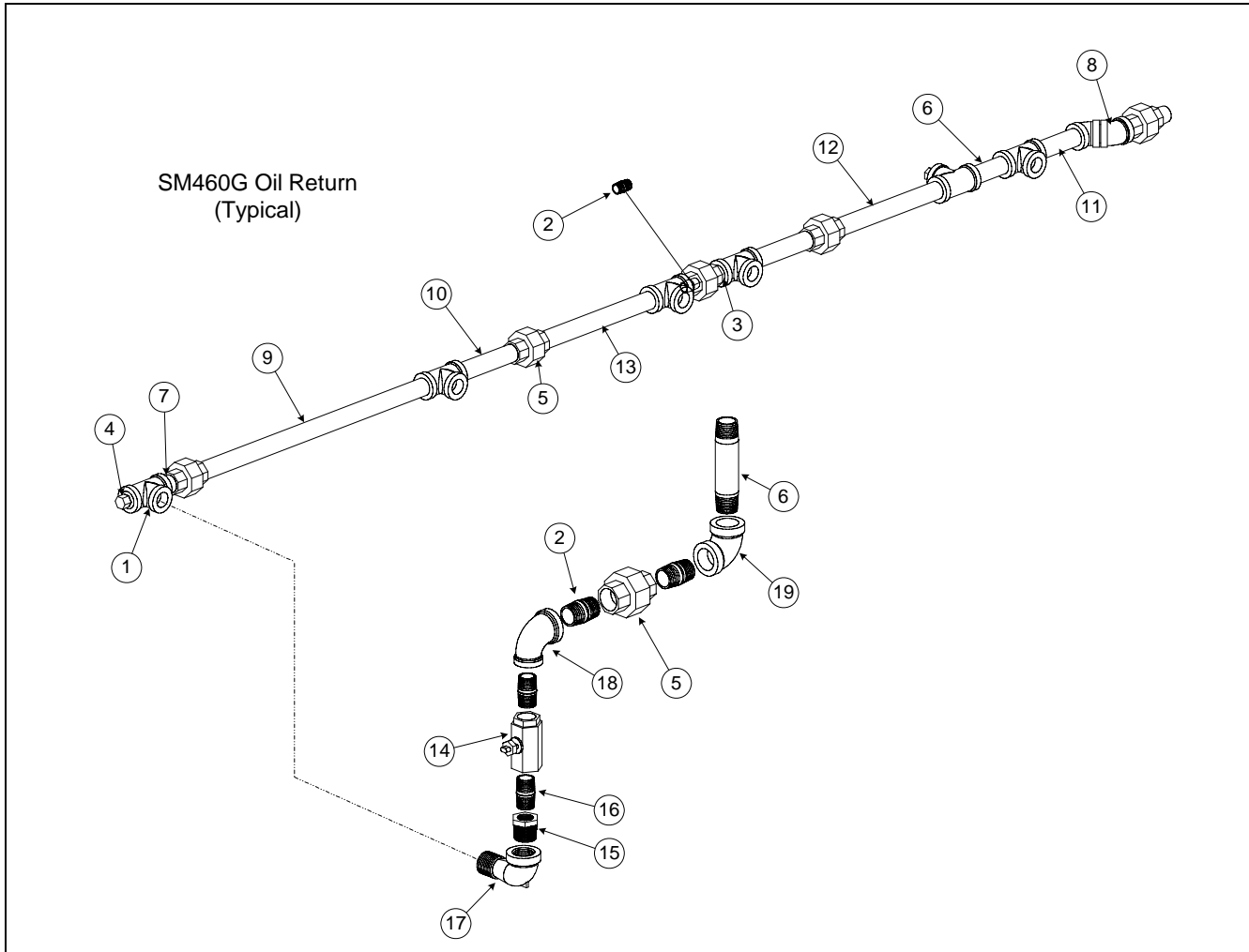

ITEM	PART #	COMPONENT
1	813-0003	Tee, ½" x ½" x ½" BM
2	813-0022	Nipple, ½" x Close NPT BM
3	813-0087	Nipple, ½" x 1-½" NPT BM
4	813-0156	Plug, ½" NPT Hex Head BM
5	813-0173	Union, ½" NPT BM
6	813-0247	Nipple, ½" x 3-½" NPT BM
7	813-0298	Nipple, ½" x 2" NPT BM
8	813-0345	Elbow, ½"- 45°
9	813-0368	Nipple, ½" x 16" NPT BM
10	813-0646	Nipple, ½" x 5" NPT BM
11	813-0654	Nipple, ½" x 4" NPT BM
12	813-0672	Nipple, ½" x 8" NPT BM

**DEAN MILLIVOLT GAS FRYERS  
CHAPTER 2: PARTS LIST**

**2.6.1 Oil Return Manifold Components; Fryers with 1½” Drains (cont.)**

ITEM	PART #	COMPONENT
13	813-0673	Nipple, ½” x 8-½” NPT BM
14	810-2125	Oil Return Valve, ¾”
*	810-0051	Coupling, ½” NPT x 1- <sup>7</sup> / <sub>16</sub> ” to adapt return hose to valve
*	200-1143	Retainer, Oil Return Valve Nut
*	809-0877	Nut, Oil Return Valve
15	813-0006	Bushing, Hex- ½” x ¾” NPT BM
16	813-0625	Nipple, ¾” x Close NPT BM
17	813-0165	Elbow, Street- ½” x ½” NPT 90° BM
18	813-0634	Elbow, ½” x ¾” NPT 90° BM
19	813-0062	Elbow, ½” NPT 90° BM
*	106-2568SP	Wash Down Hose and Nozzle Assembly

\* Not Illustrated

## DEAN MILLIVOLT GAS FRYERS CHAPTER 2: PARTS LIST

### 2.6.2 Oil Return Manifold Components; Fryers with 3" Drains

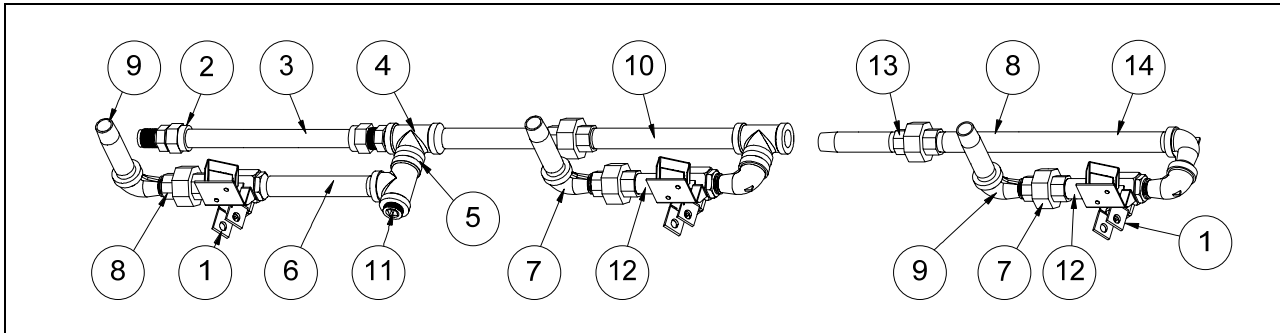

ITEM	PART #	COMPONENT
	106-4100	Oil Return Assembly – Middle
	106-4101	Oil Return Assembly – End
1	106-4006	Valve Assembly, ½" Oil Return (see Page 2-25)
*	106-3997	Valve Assembly (use with wand)
*	106-5516	Valve Assembly, 3-way Oil Return
2	810-1668	Adapter, Male ⅝" OD x ½"
3	810-2320	Flexline, ⅝" x 9.00" Long
4	813-0003	Tee, ½" x ½" x ½" BM
5	813-0022	Nipple, ½" x Close NPT BM
6	813-0096	Nipple, ½" x 6.00" NPT BM
7	813-0165	Elbow, Street ½" x ½" NPT 90° BM
8	813-0173	Union, ½" NPT
9	813-0247	Nipple, ½" x 3.50" NPT BM
10	813-0362	Nipple, ½" NPT x 7.50" BM
11	813-0463	Plug, ½" Counter Sink
12	813-0661	Nipple, ½" x 2.25" NPT BM
13	813-0654	Nipple, ½" x 4.00" NPT BM
14	813-0597	Nipple, ½" x 11.50" NPT BM
*	810-2125	Ball Valve, ⅜" Drain
*	813-0006	Bushing, ½" to ⅜" NPT BM Hex Reducing
*	813-0062	Elbow, ½" 90° BM
*	810-1067	Flexline, 8.50" Oil Return
*	813-0087	Nipple, ½" x 1.50" NPT BM
*	813-0460	Nipple, ½" x 3.00" NPT BM
*	813-0625	Nipple, ⅜" NPT x CL Black CLS
*	813-0672	Nipple, ½" x 8.00" NPT BM
*	813-0607	Nipple, ½" x 23.50" NPT BM
*	813-0099	Nipple, ½" x 7.00" NPT BM
*	813-0845	Nipple, ½" x 29.75" NPT BM
*	813-0646	Nipple, ½" x 5.00" NPT BM
*	813-0373	Nipple, ½" x 11.00" NPT BM
*	813-0298	Nipple, ½" x 2.00" NPT BM
*	813-0098	Nipple, ½" x 6.50" NPT BM
*	813-0742	Nipple, ½" x 5.50" NPT BM
*	813-0515	Nipple, ½" x 12.00" NPT BM
*	813-0265	Nipple, ½" x 2.50" NPT BM
*	813-0093	Nipple, ½" x 4.00" NPT BM

\* Not Illustrated

# DEAN MILLIVOLT GAS FRYERS

## CHAPTER 2: PARTS LIST

### 2.7 Oil Return and Oil Flush Components

#### 2.7.1 Oil Return and Oil Flush Components; Fryers with 1½" Drains\*

\*Typical components illustrated below. Components will vary according to system.

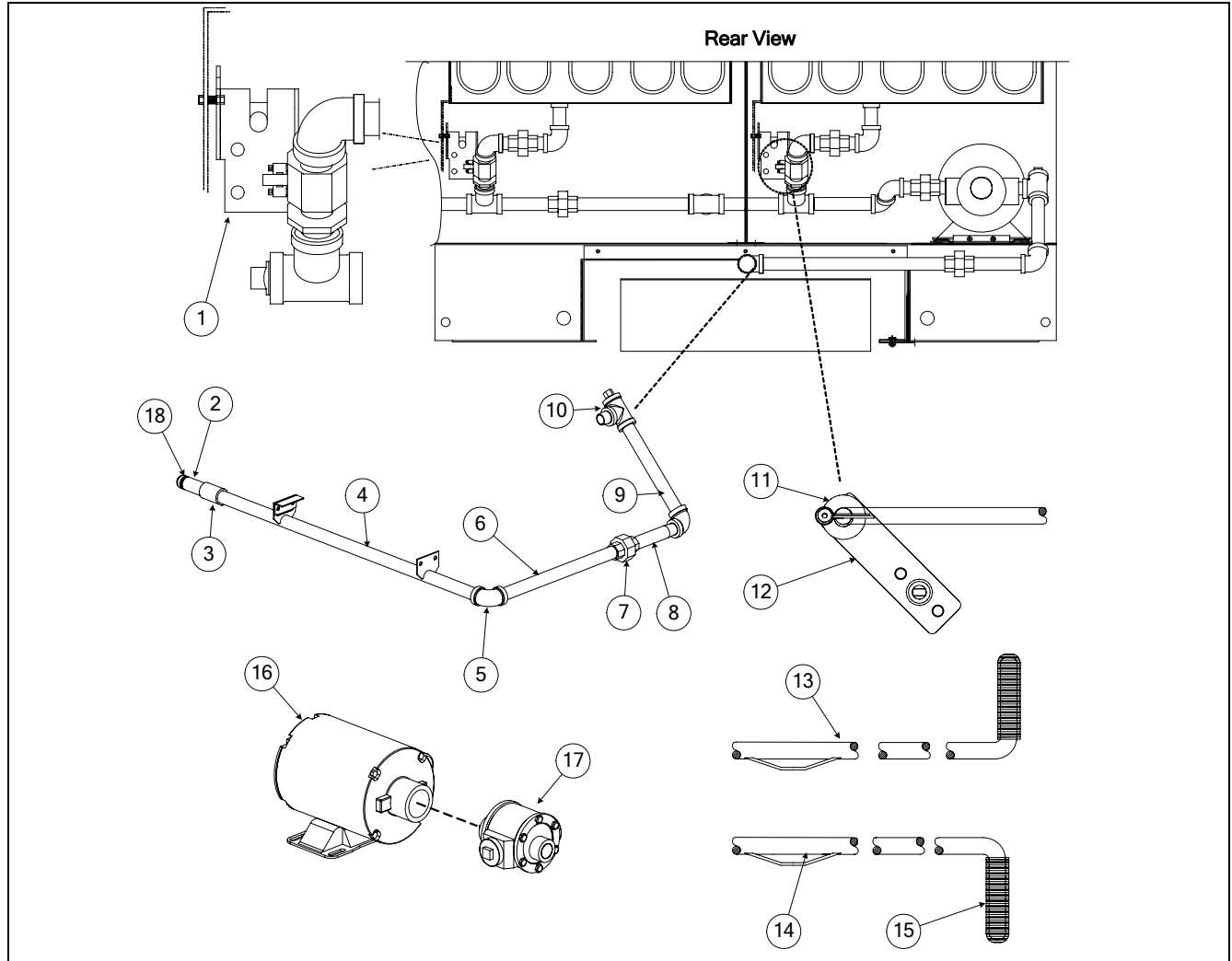

**DEAN MILLIVOLT GAS FRYERS  
CHAPTER 2: PARTS LIST**

**2.7.1 Oil Return and Oil Flush Components; Fryers with 1½” Drains (cont.)**

ITEM	PART #	COMPONENT
1		<b>Microswitch Bracket Assembly, Oil Return</b>
*	201-1233	Bracket, Oil Return Microswitch- Left
*	202-1233	Bracket, Oil Return Microswitch- Right
*	810-2144	Spacer, Aluminum, 4-40- ¼" x 3/8"
*	807-2104	Microswitch, Oil Return
*	809-0846	Screw, 4-40 x 1" Slotted Head
*	809-0842	Nut, Nylock- 4-40
*	200-1341	Bracket, Microswitch Rod
*	809-0360	Screw, #8 x ¾" Hex Washer Slotted Head
*	809-0803	Bolt, ¼"-20 x ¾" Hex Head Grade 5
*	809-0823	Nut, Nylock, ¼"-20
*	809-0070	Nut, ¼"-20 Hex S/S
2	810-0697	Disconnect, Male- Suction Tube
3	813-0608	Coupling, Full- ½" NPT BM
4	823-3188	Suction Manifold Assembly
5	813-0062	Elbow, 90° BM
6	813-0515	Nipple, ½" x 12" NPT BM
7	813-0173	Union, ½" NPT BM
8	813-0251	Nipple, ½" x 4-½" NPT BM
9	813-0672	Nipple, ½" x 8" NPT BM
10		<b>Oil Suction Start Fitting</b>
*	813-0022	Nipple- ½" NPT x Close
*	813-0156	Plug, ½" NPT Hex Head
*	813-0003	Tee, ½" NPT BM
11	809-0885	Washer, ⅜" x 1" x .083"
*	809-0843	Pin, Cotter- Plated
12	823-3344	Handle (Actuator), Oil Return Valve
13	823-3187	Handle, Oil Return- Left Fryer-UFF System
14	823-3198	Handle, Oil Return- Right Fryer-UFF System
*	823-3481	Handle, Oil Flush Valve
15	816-0548	Cap, Oil Return Handle- Yellow
*	816-0549	Cap, Oil Flush Handle- Blue
16	810-2100	Motor, Pump- 120-230V
*	826-1987	Motor, Pump Assembly 5 GPM
17	810-2098	Pump, 8 GPM
*	810-2252	Pump, 5 GPM
*	210-1650	Oil Deflector, Oil Return
18	826-1392	O-Rings (Pkg. of 5)
*	106-2949SP	Line Assembly, Garland Pump Suction
*	KIT4678SP	Wash Down Hose Fittings Kit
*	807-3593	Power Cord
*	807-3611	Relay, Filter 24A DPDT

\* Not Illustrated

# DEAN MILLIVOLT GAS FRYERS

## CHAPTER 2: PARTS LIST

### 2.7.2 Oil Return and Oil Flush Components; Fryers with 3" Drains

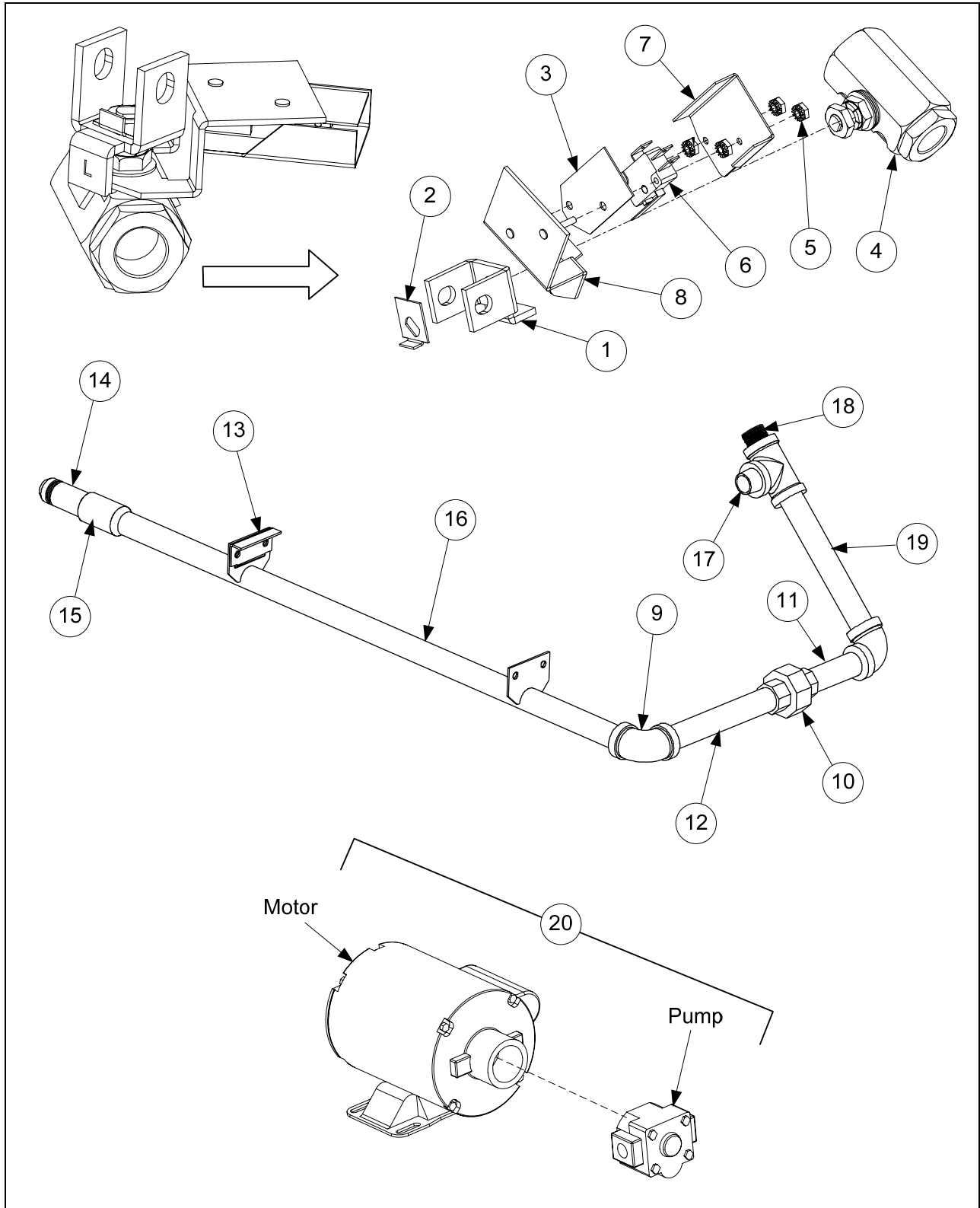



**DEAN MILLIVOLT GAS FRYERS  
CHAPTER 2: PARTS LIST**

**2.7.2 Oil Return and Oil Flush Components; Fryers with 3" Drains (cont.)**

<b>ITEM</b>	<b>PART #</b>	<b>COMPONENT</b>
	106-4006	<b>Microswitch Bracket Assembly, Oil Return</b>
1	901-2772	Handle, RF Left
2	900-2935	Retainer, Nut
3	816-0220	Insulation, RF Switch
4	810-0278	Ball Valve, 1/2" Oil Return
5	826-1366	Nut, 4-40 Keps hex w/ External Teeth (Pkg. of 25)
6	807-2103	Microswitch, Straight Lever (CE)
7	200-6806	Cover, Safety Switch
8	106-3962	Bracket Assembly, RF Switch
	106-1225	<b>Oil Suction Assembly</b>
9	813-0062	Elbow, 90° BM
10	813-0173	Union, 1/2" NPT 150# BM
11	813-0654	Nipple, TBE 1/2" NPT x 4" BM
12	813-0674	Nipple, TBE 1/2" NPT x 7.25" BM
13	200-1230	Bracket, Front male Manifold
	106-0774	<b>Suction Manifold Assembly</b>
14	810-0697	Disconnect, Male Suction Tube
15	813-0608	Coupling, 1/2" NPT BM Full
16	823-3188	Suction Manifold
	106-0858	<b>Oil Suction Start Fitting</b>
17	813-0022	Nipple, 1/2" NPT Close
18	813-0463	Plug, 1/2" Counter Sink
19	813-0003	Tee, 1/2" NPT BM
*	210-8790	Bracket, Oil Return/ Flush Retainer
*	200-8929	Handle, Oil Return
*	200-9850	Handle, Oil Return (Application Series "DF" Fryers)
*	816-0548	Cap, Oil Return Handle, Yellow
*	816-0549	Cap, Oil Return Handle, Blue
20	810-2097	Motor/Pump Combo, 120-230V

\* Not Illustrated

# DEAN MILLIVOLT GAS FRYERS

## CHAPTER 2: PARTS LIST

### 2.8 Under Fryer Filter (UFF) Components

#### 2.8.1 SM50 and SM60 Series Fryers (Except IHOP)

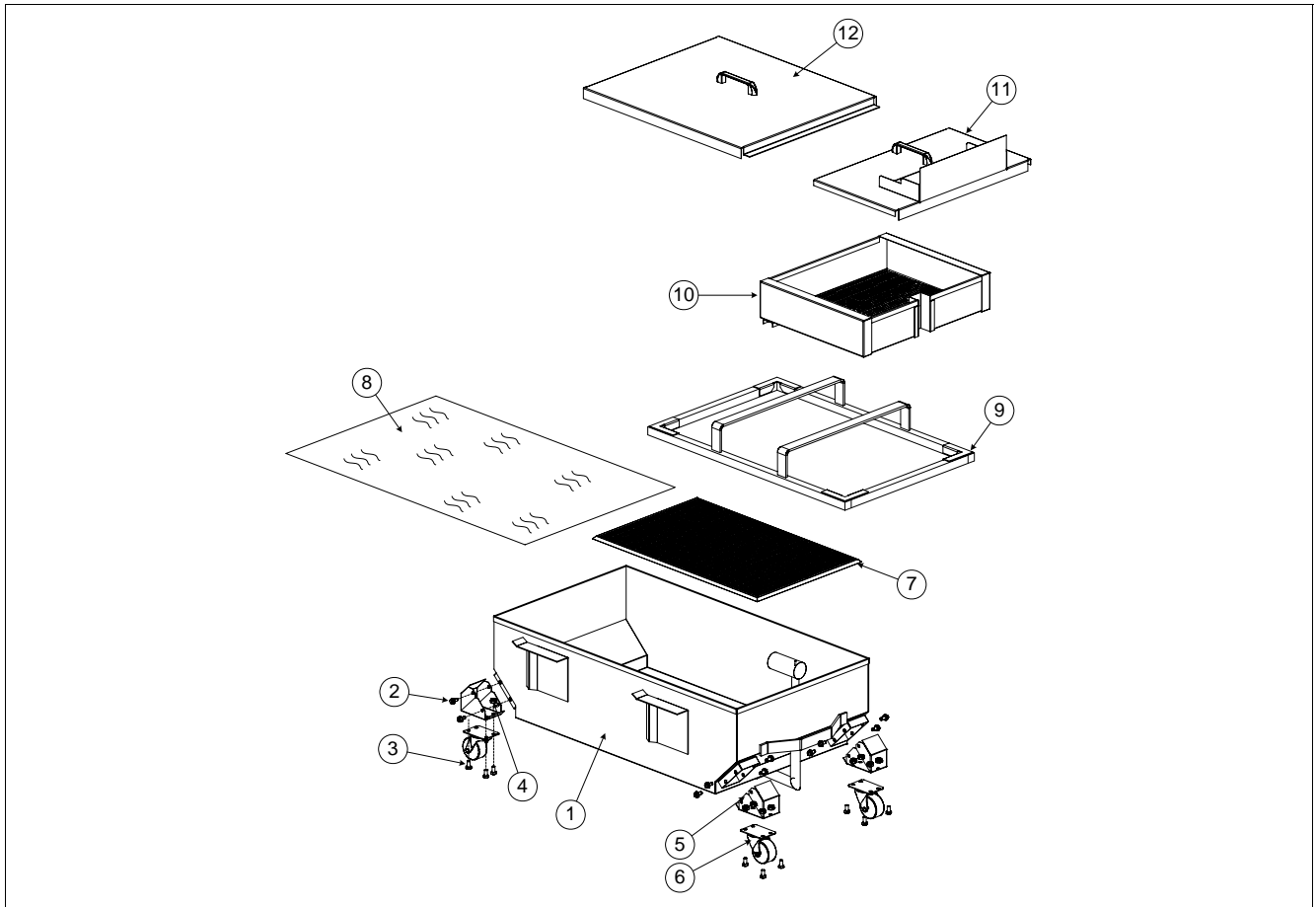

ITEM	PART #	COMPONENT
1	823-3576	Filter Pan- UFF 50
*	106-2115SP	Filter Pan Assembly- UFF 50
*	106-0749SP	Filter Pan Assembly- UFF 60
2	809-0805	Screw, ¼"-20 x ½"
3	809-0428	Bolt, ¼"-20 x ½" Steel
4	809-0820	Nut, Oval Locking- ¼"-20
5	823-4794	Insert, Caster
6	810-2805	Caster, 2"-Swivel
7	823-3574	Support Grid (Bottom Pan Screen)- UFF 50
*	823-3365	Support Grid (Bottom Pan Screen)- UFF 60
8	803-0289	Filter Paper, 22" x 34"- UFF 50/60 (100 Sheets)
9	823-3573	Hold-down Ring, Weighted- UFF 50
*	823-3361	Hold-down Ring, Weighted- UFF 60
10	823-4320	Crumb Basket, UFF 50/60
11	106-0752SP	Lid Assembly, Front- UFF 50/60
12	106-1755SP	Lid Assembly, Rear- UFF 50
*	106-0753SP	Lid Assembly, Rear- UFF 60

\* Not Illustrated

## DEAN MILLIVOLT GAS FRYERS CHAPTER 2: PARTS LIST

### 2.8.2 SM50 Series Fryers, IHOP UFF 50 with Filter Leaf

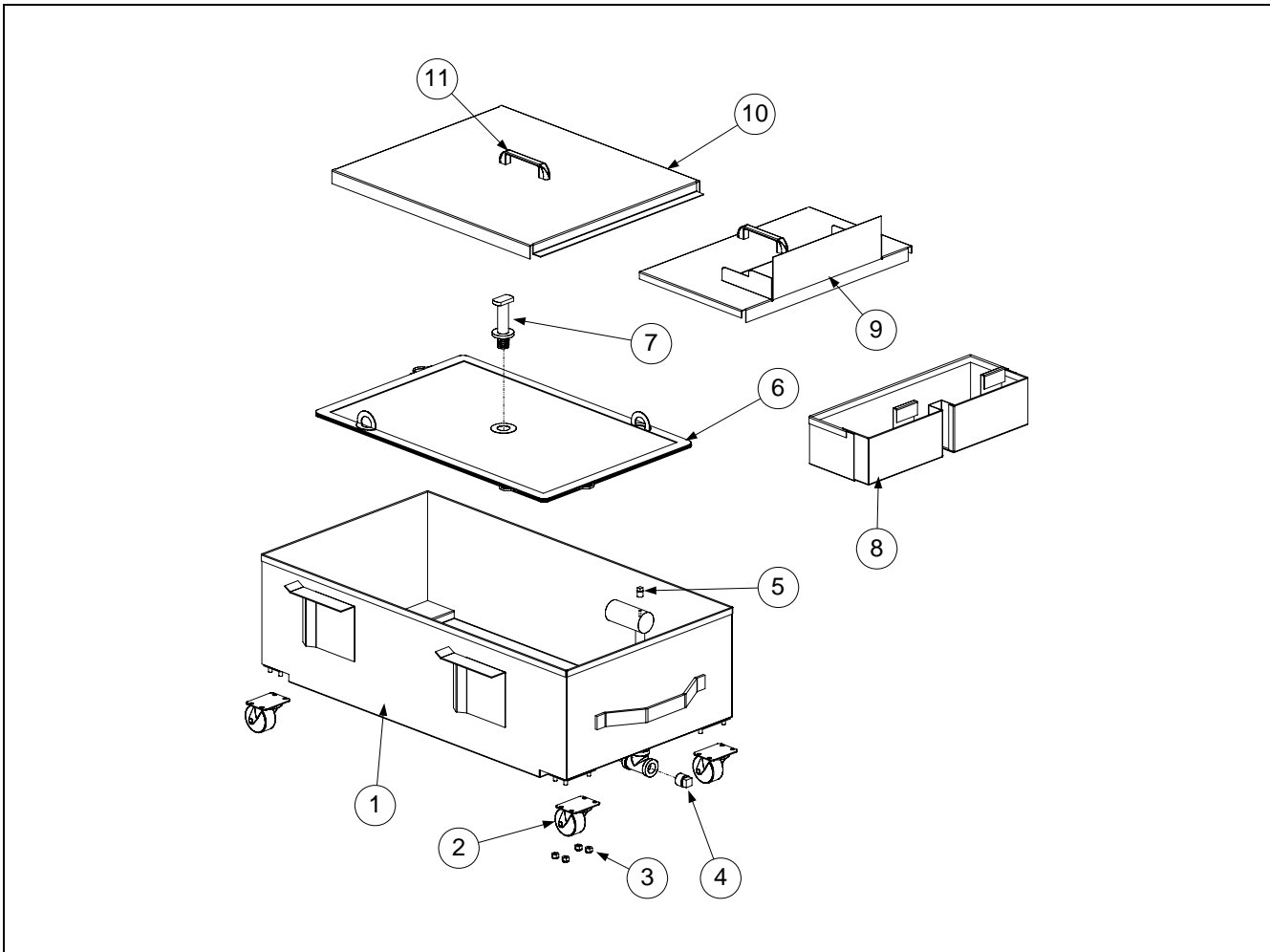

ITEM	PART #	COMPONENT
	106-2109SP	Filter Pan Assembly- UFF 50 IHOP (includes items 1-5)
1	823-3703	Filter Pan- UFF 50 IHOP
2	810-2805	Caster, 2"-Swivel
3	809-0823	Nut, Nylock ¼"-20
4	813-0336	Plug, Pipe- S/S- ½" NPT
5	813-0679	Plug, ⅛" S/S Square Head
6	810-2350	Leaf, Filter- UFF 50 IHOP
7	810-2351	Handle, Filter Leaf Tee Fitting
8	823-3872	Crumb Basket, UFF 50 IHOP
9	106-0752SP	Lid Assembly, Front- UFF 50
10	106-0753SP	Lid Assembly, Rear- UFF 60
11	810-0180	Handle, Filter Lid- Front & Back
*	809-0191	Washer, ¼" Lock- Filter Lid Handle
*	809-0918	Screw, #10-24 x ½"- Filter Lid Handle

\* Not Illustrated

## DEAN MILLIVOLT GAS FRYERS CHAPTER 2: PARTS LIST

### 2.8.3 SM80 Series Fryers

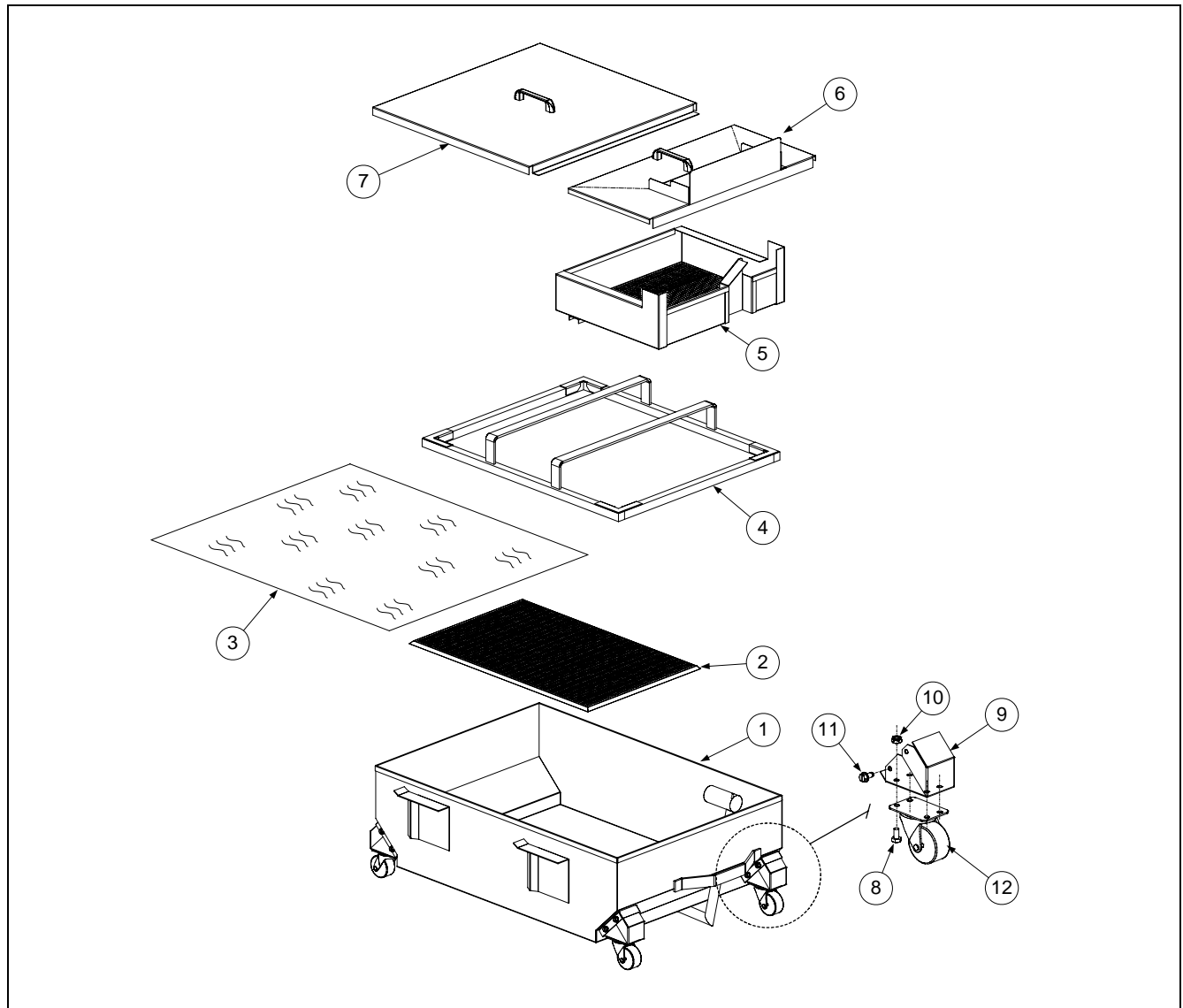

ITEM	PART #	COMPONENT
1	106-1584SP	Filter Pan, UFF 80
2	823-3365	Support Grid (Bottom Pan Screen) (Use 823-4938 for Chili's)
3	803-0303	Filter Paper, 26" x 34" (100 Sheets)
4	823-3439	Hold-down Ring, Weighted
5	823-3443	Crumb Basket
6	106-1587SP	Filter Pan Cover, Front
7	106-1588SP	Filter Pan Cover, Back
8	809-0428	Bolt, ¼"-20 x ½" Steel
9	823-4794	Insert, Castor
10	809-0820	Nut, Oval Locking- ¼" -20
11	809-0805	Screw, ¼"-20 x ½"
12	810-2805	Castor, 2"

**DEAN MILLIVOLT GAS FRYERS  
CHAPTER 2: PARTS LIST**

**2.9 Single Under Fryer Filter (SUFF) Components**

**2.9.1 SM50 Series Fryers**

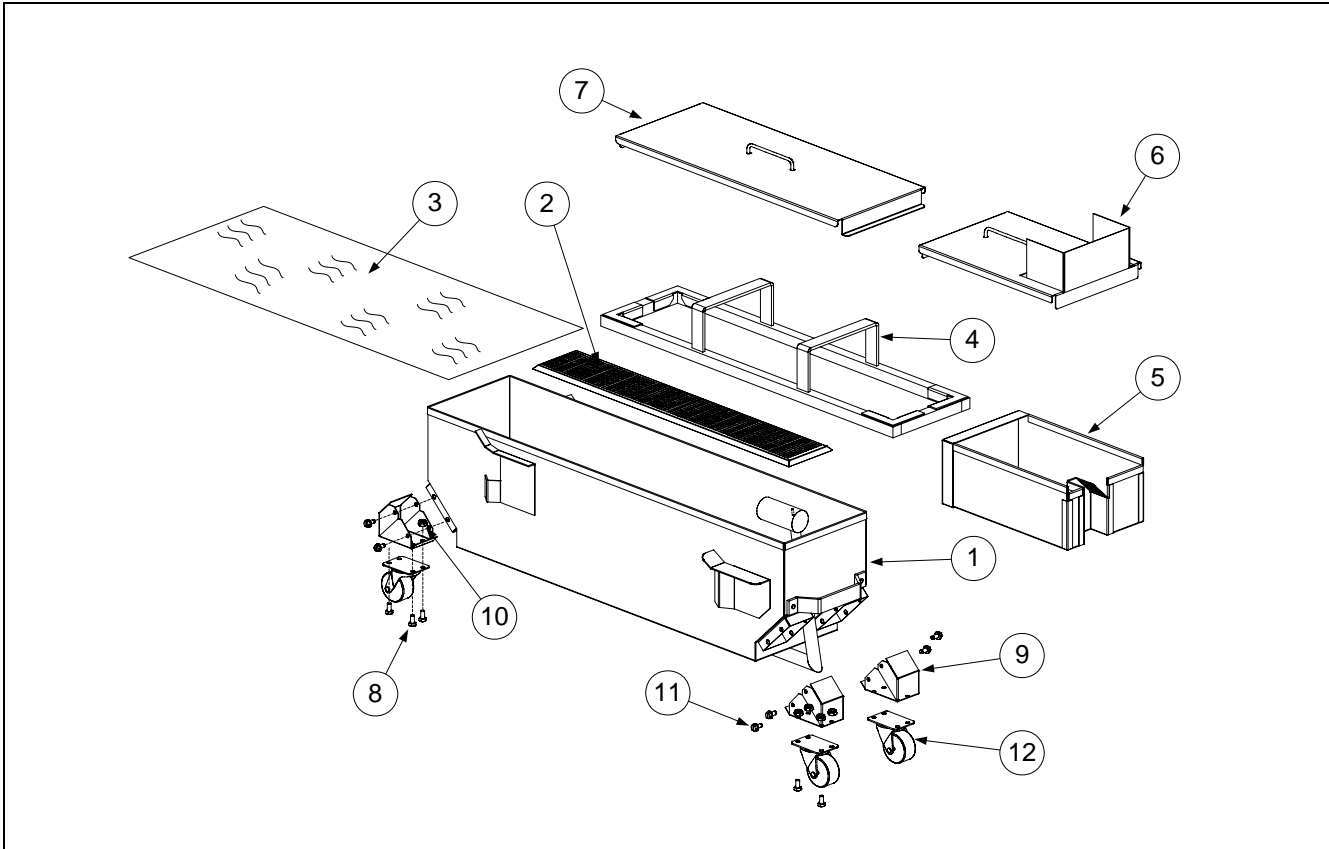

ITEM	PART #	COMPONENT
	106-2257SP	Filter Pan Assembly SUFF 50
1	823-3796	Filter Pan, SUFF 50
*	813-0684	Plug, Hex Socket, 3/8" NPT
*	813-0679	Plug, 1/8" S/S Square Head (Female Disconnect)
2	823-3790	Support Grid (Bottom Pan Screen)
3	803-0317	Paper, Filter- 8-1/4" x 25-3/4"
4	823-3795	Hold-down Ring, Weighted
5	823-3736	Crumb Basket
6	823-3797	Filter Pan Cover, Front
7	823-3798	Filter Pan Cover, Back
8	809-0428	Bolt, 1/4" -20 x 1/2" Steel
9	823-4794	Insert, Castor
10	809-0820	Nut, Oval Locking- 1/4" -20
11	809-0805	Screw, 1/4" -20 x 1/2"
12	810-2805	Castor, 2"

\* Not Illustrated

## DEAN MILLIVOLT GAS FRYERS CHAPTER 2: PARTS LIST

### 2.9.2 SM60 and SM80 Series Fryers

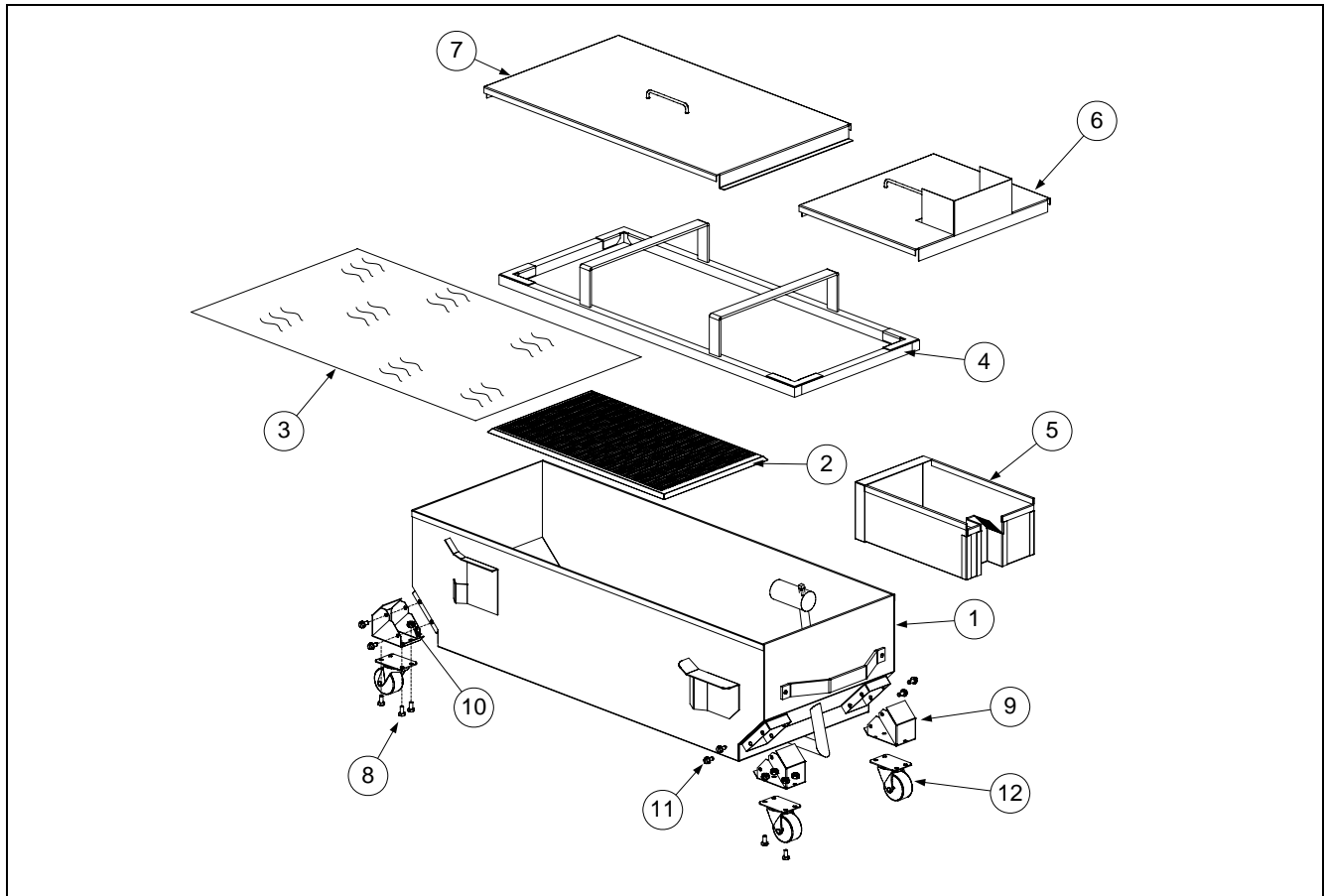

ITEM	PART #	COMPONENT
1	823-3774	Filter Pan, SUFF 60 (Use 106-2228SP for Assembly)
*	823-3821	Filter Pan, SUFF 80 (Use 106-2381SP for Assembly)
*	813-0684	Plug, Hex Socket, 3/8" NPT
*	813-0679	Plug, 1/8" S/S Square Head (Female Disconnect)
2	823-3768	Support Grid (Bottom Pan Screen) SUFF 60/80
3	803-0289	Paper, Filter- 22" x 34" - SUFF 60/80
4	823-3768	Hold-down Ring, Weighted- SUFF 60
*	823-3849	Hold-down Ring, Weighted- SUFF 80
5	823-3736	Crumb Basket- SUFF 60/80
6	823-3766	Filter Pan Cover, Front- SUFF 60
*	823-3739	Filter Pan Cover, Front- SUFF 80
7	823-3767	Filter Pan Cover, Back- SUFF 60
*	823-3741	Filter Pan Cover, Back- SUFF 80
8	809-0428	Bolt, 1/4" -20 x 1/2" Steel
9	823-4794	Insert, Caster
10	809-0820	Nut, Oval Locking- 1/4"-20
11	809-0805	Screw, 1/4" -20 x 1/2"
12	810-2805	Caster, 2"

\* Not Illustrated

**THIS PAGE INTENTIONALLY LEFT BLANK.**



**Enodis**<sup>®</sup>  
One Company, Countless Solutions

**Dean, 8700 Line Avenue, PO Box 51000, Shreveport, Louisiana 71135-1000**  
**Shipping Address: 8700 Line Avenue, Shreveport, Louisiana 71106**

**TEL 1-318-865-1711**

**FAX (Parts) 1-318-327-3343**

**FAX (Tech Support) 1-318-219-7135**

**PRINTED IN THE UNITED STATES**

**SERVICE HOTLINE**  
**1-800-551-8633**

**819-5948**  
**MAY 2007**



## Free Manuals Download Website

<http://myh66.com>

<http://usermanuals.us>

<http://www.somanuals.com>

<http://www.4manuals.cc>

<http://www.manual-lib.com>

<http://www.404manual.com>

<http://www.luxmanual.com>

<http://aubethermostatmanual.com>

Golf course search by state

<http://golfingnear.com>

Email search by domain

<http://emailbydomain.com>

Auto manuals search

<http://auto.somanuals.com>

TV manuals search

<http://tv.somanuals.com>