

CT16 Series Toaster

Service and Parts Manual



Frymaster®



Frymaster, a member of the Commercial Food Equipment Service Association, recommends using CFESA Certified Technicians.

24-Hour Service Hotline 1-800-551-8633

JANUARY 2004

*** 8195993 ***

NOTICE

IF, DURING THE WARRANTY PERIOD, THE CUSTOMER USES A PART FOR THIS ENODIS EQUIPMENT OTHER THAN AN UNMODIFIED NEW OR RECYCLED PART PURCHASED DIRECTLY FROM FRYMASTER/DEAN, OR ANY OF ITS AUTHORIZED SERVICE CENTERS, AND/OR THE PART BEING USED IS MODIFIED FROM ITS ORIGINAL CONFIGURATION, THE WARRANTY WILL BE VOID. FURTHER, FRYMASTER/DEAN AND ITS AFFILIATES WILL NOT BE LIABLE FOR ANY CLAIMS, DAMAGES OR EXPENSES INCURRED BY THE CUSTOMER WHICH ARISE DIRECTLY OR INDIRECTLY, IN WHOLE OR IN PART, DUE TO THE INSTALLATION OF ANY MODIFIED PART AND/OR PART RECEIVED FROM AN UNAUTHORIZED SERVICE CENTER.

NOTICE

This appliance is intended for professional use only and is to be operated by qualified personnel only. A Frymaster/DEAN Factory Authorized Service Center (FASC) or other qualified professional should perform installation, maintenance, and repairs. Installation, maintenance, or repairs by unqualified personnel may void the manufacturer's warranty.

NOTICE

This equipment must be installed in accordance with the appropriate national and local codes of the country and/or region in which the appliance is installed.

NOTICE TO U.S. CUSTOMERS

This device complies with Part 15 of the FCC rules. Operation is subject to the following two conditions: 1) This device may not cause harmful interference, and 2) This device must accept any interference received, including interference that may cause undesired operation. While this device is a verified Class A device, it has been shown to meet the Class B limits.

NOTICE TO CANADIAN CUSTOMERS

This digital apparatus does not exceed the Class A or B limits for radio noise emissions as set out by the ICES-003 standard of the Canadian Department of Communications.

Cet appareil numérique n'émet pas de bruits radioélectriques dépassant les limites de classe A et B prescrites dans la norme NMB-003 édictée par le Ministre des Communications du Canada.

 DANGER

Improper installation, adjustment, maintenance or service, and unauthorized alterations or modifications can cause property damage, injury, or death. Read the installation, operating, and service instructions thoroughly before installing, operating or servicing this equipment.

Do not operate the CT16 Toaster unless it has been properly installed and checked.

Do not operate the CT16 Toaster unless all covers and access panels are in place and properly secured.

Do not attempt to repair or replace any component of the CT16 Toaster unless all power to the unit has been disconnected.

Use caution when setting up, operating, or cleaning the CT16 Toaster to avoid contact with heated surfaces.

 DANGER

Do not store or use gasoline or other flammable liquids or vapors in the vicinity of this or any other appliance.

CT16 SERIES TOASTER

SERVICE AND PARTS MANUAL

CHAPTER 1: SERVICE PROCEDURES

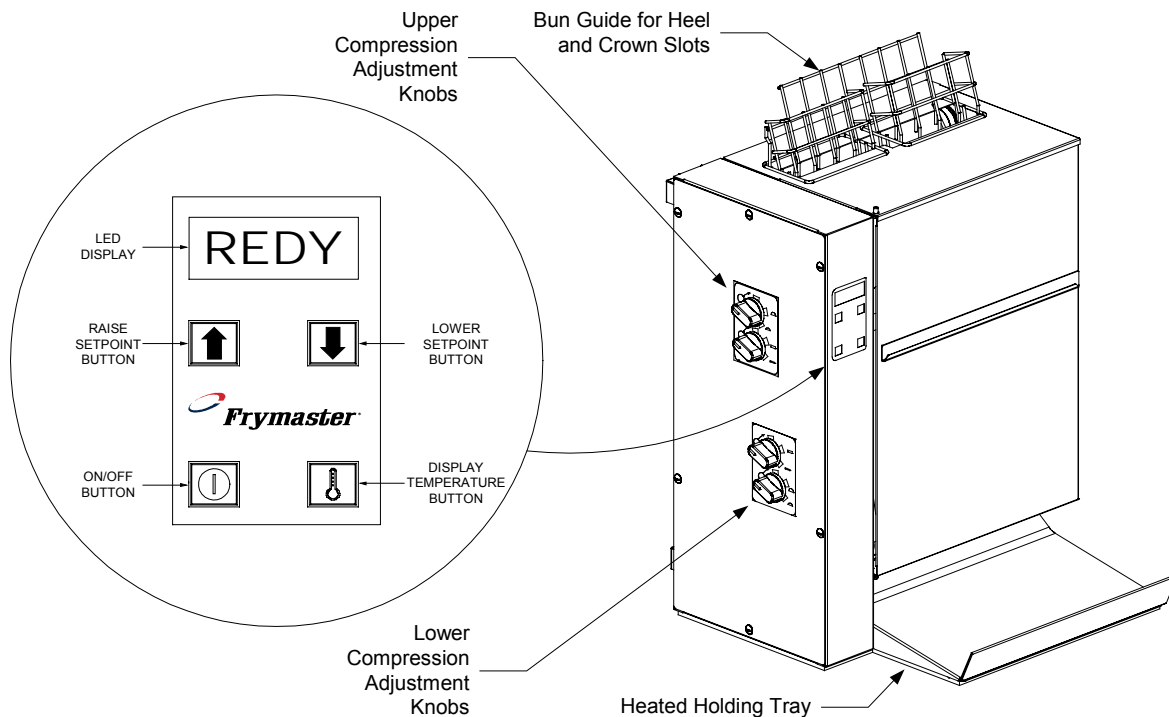

1.1 CT16 Toaster Functional Description

The CT16 Toaster is designed to produce fresh, uniformly toasted buns on an "as needed" basis. The countertop-mounted unit consists of a cabinet, a computer, a heating element and a pair of conveyor assemblies.

When the unit is turned on, an electrical heating element (called a *platen*) is energized. The platen heats up to a programmed temperature referred to as the *setpoint*. At the same time, both conveyor assemblies are activated. When a bun is placed into one of the slots at the top of the cabinet, the conveyor belts gently carry it through the unit, with the cut face of the bun passing over the heated platen. As the bun passes over the platen, it is toasted. At the end of the process, the bun is deposited onto a holding tray. The computer allows the operator to adjust the setpoint to obtain desired toasting characteristics. Compression adjustment knobs also allow the operator to adjust the compression of heels and crowns as they pass through the toaster.

1.2 Power Requirements

ALL ELECTRICALLY OPERATED APPLIANCES MUST BE ELECTRICALLY GROUNDED IN ACCORDANCE WITH LOCAL CODES, OR IN THE ABSENCE OF LOCAL CODES, WITH THE NATIONAL ELECTRICAL CODE (ANSI/NFPA NO. 70-1990) OR THE CORRESPONDING NATIONAL CODE OF THE COUNTRY IN WHICH INSTALLED.

THIS APPLIANCE IS EQUIPPED WITH A GROUNDING PLUG FOR YOUR PROTECTION AGAINST SHOCK HAZARD AND MUST BE PLUGGED INTO A PROPERLY GROUNDED RECEPTACLE. DO NOT CUT OR REMOVE THE GROUNDING PRONG FROM THIS PLUG!

- Voltage: 200VAC, 208VAC, or 240VAC, depending on model ordered
- Frequency: 60 Hz (non-CE) or 50 Hz (CE and Australian models)
- Phase: Single
- Service: 20 Amp

1.3 Replacing Components

Accessing the Electronics

1. Pull the bun compression knobs off their shafts.
2. Remove the screws around the edge of the component housing cover and remove the cover.

Accessing the Drive Motor and Auxiliary Transformer

Carefully lay the unit on its back and remove the seven screws that secure the bottom cover in place.

Removing the Conveyor Assemblies

1. Turn off and unplug the unit.
2. Remove the bun feeder then remove the cover by lifting it straight up until it is clear of its hinge pins.
3. Rotate the bun compression knobs to positions **5** and **E**.
4. Press down on the top roller(s) of the conveyor assembly to be removed to lock it (them) in the down position.
5. Rotate the tray stabilizer latch upward, then remove the belt(s). Return the tray stabilizer latch to the latched position.
6. Pull the bun compression knobs from their shafts.
7. Remove the screws around the edge of the component housing cover and remove the cover.
8. Remove the diagonal brace.
9. Release the tension on the drive belt by pressing down on the belt tensioner arm and remove the belt from the pulleys.
10. **To remove the dual-belt conveyor assembly:**
(See illustration on following page.)
 - a. Loosen the setscrew in the forward-most drive pulley and remove the pulley.
 - b. Remove the cartridge heater, marking the leads to facilitate reconnection.
 - c. Remove the four hex-head screws and two flange nuts that secure the conveyor assembly to the component housing from the inside.
 - d. Rotate the tray stabilizer latch upward and, while supporting the conveyor assembly, remove the two hex-head screws securing the top of the conveyor assembly from the outside (conveyor side) of the component housing and carefully pull the conveyor assembly away from the housing.
 - e. Reinstall the conveyor assembly by reversing the steps performed, being sure to reattach the ground wire with the top hex head screw.

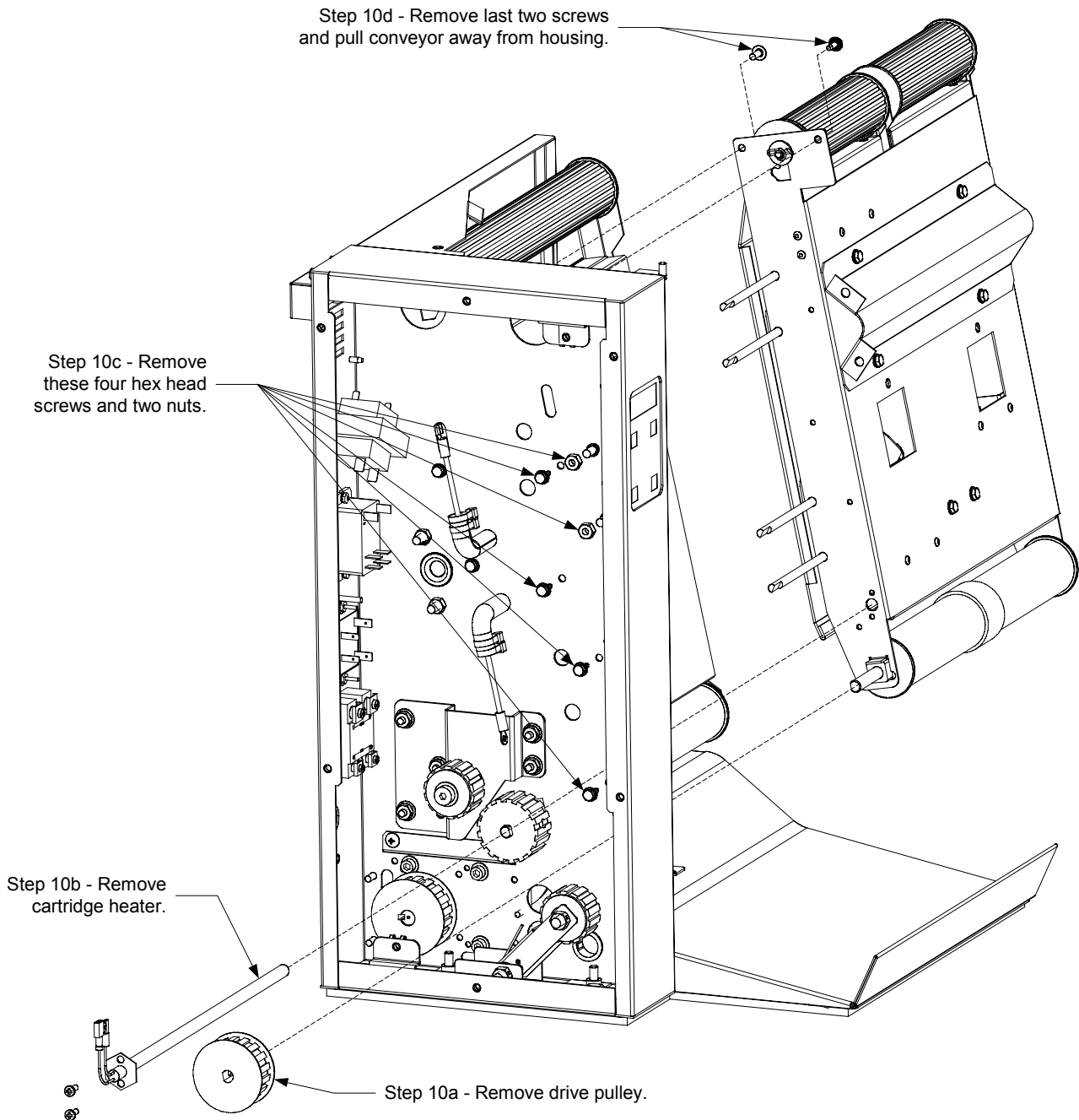

11. To remove the toasting conveyor assembly:

(See illustration on following page.)

- a. Detach the platen and probe wiring from the relay, high-limit, and 9-pin connector.
- b. Loosen the setscrew in the second drive pulley from the front and remove the pulley.
- c. Remove the five flange nuts that secure the idler assembly to the housing and remove the idler assembly.
- d. Remove the two hex head screws shown in Step 11d of the illustration on the following page.

- e. Rotate the tray stabilizer latch upward and, while supporting the conveyor assembly, remove the hex-head screw securing the top of the assembly from the outside (conveyor side) of the component housing and carefully pull the assembly away from the housing.

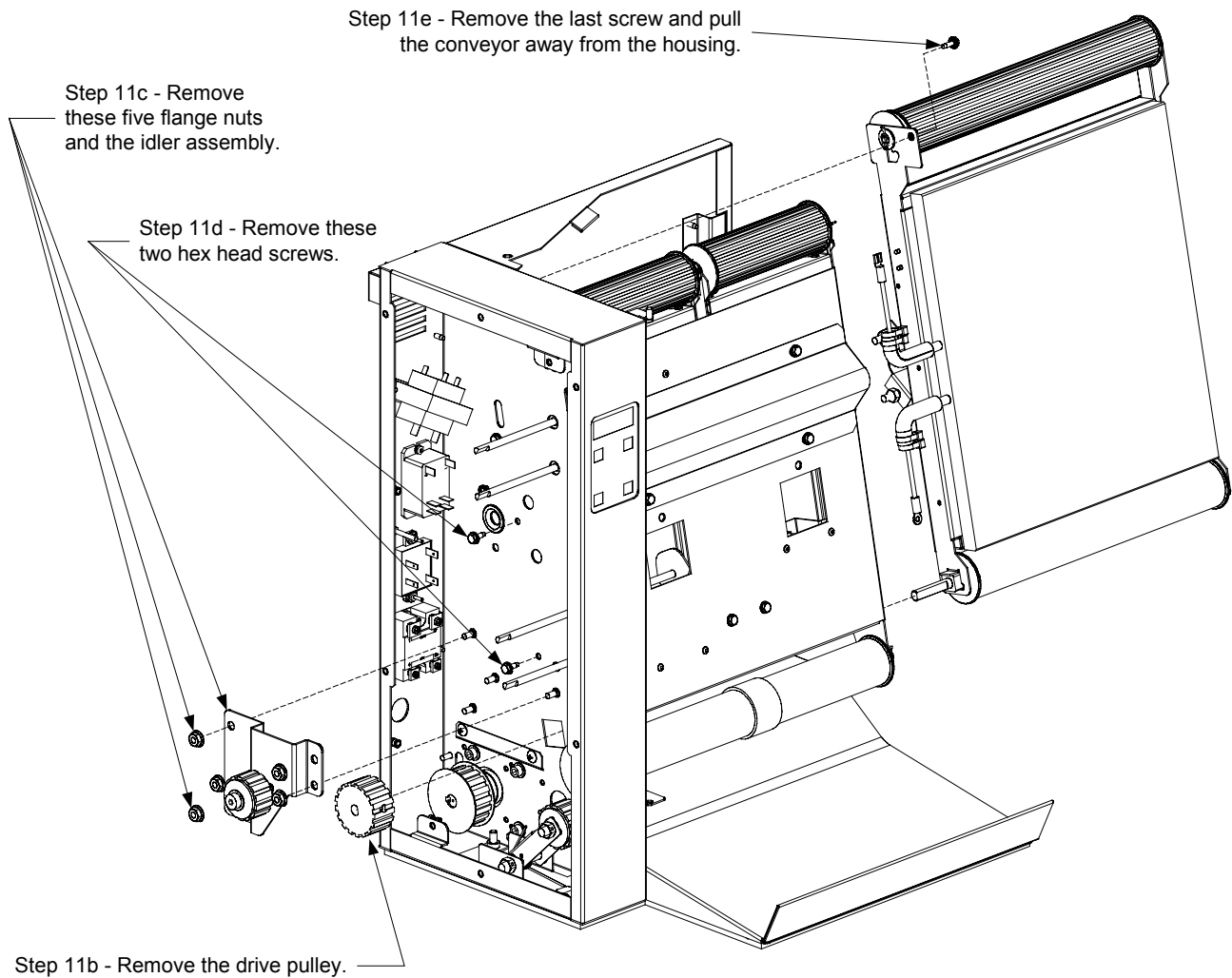

- f. Reinstall the conveyor assembly by reversing the steps performed, being sure to reattach the two ground wires with the lower of the two hex head screws removed in Step 11d.

Replacing the High-Limit Thermostat or Heater Probe

(See illustration on following page.)

1. Turn off and unplug the unit, and remove toasting conveyor in accordance with the instructions on Pages 18-19.
2. **To replace the high-limit thermostat**, remove the platen tray brace to expose the thermostat and remove the screws securing it in place.
3. **To replace the heater probe**, remove the plug over the probe to expose the component. Remove the screw securing the probe retainer and remove the probe.

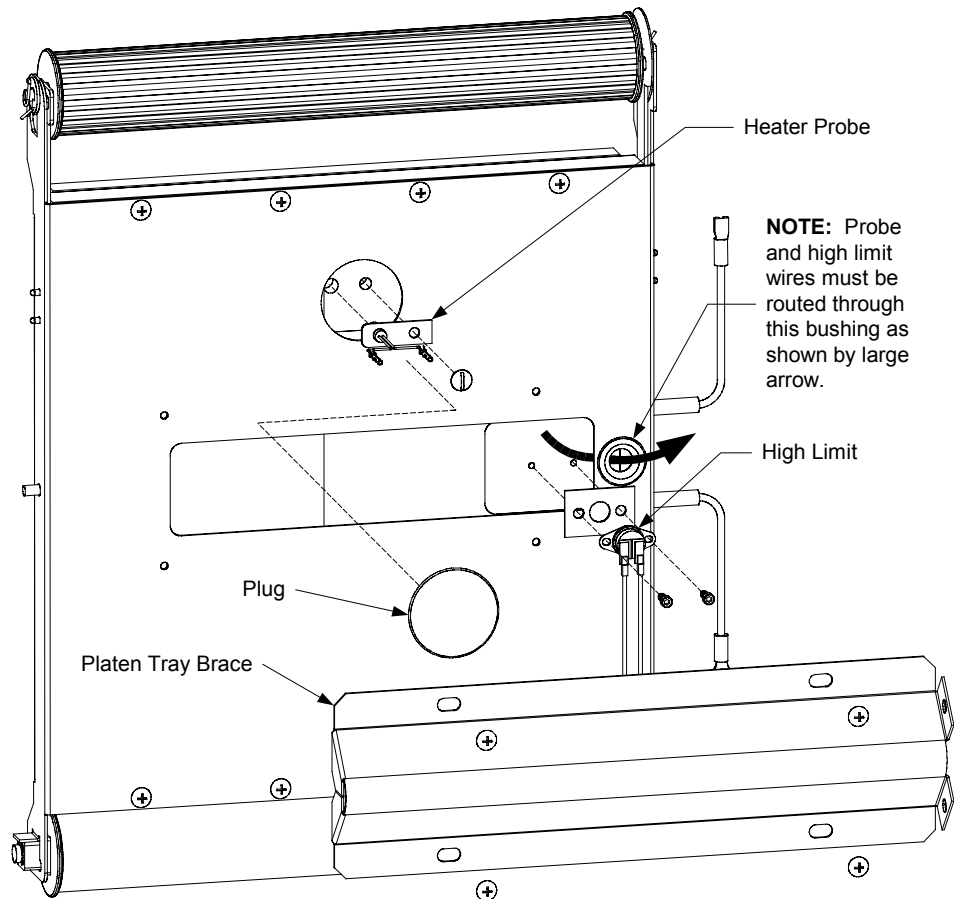

4. Replace the failed component, being sure to route the component wires through the bushing as shown in the illustration above. Reassemble by reversing the steps performed and reconnect the wiring in accordance with the wiring diagram on the inside of the component housing cover.

Replacing the Drive Motor or Auxiliary Transformer

(See illustration on following page.)

1. Turn off and unplug the unit.
2. Pull the bun compression knobs from their shafts.
3. Remove the screws around the edge of the component housing cover.
4. Disconnect the failed component's wiring, then carefully lay the unit on its back.
5. Remove the screws that secure the bottom cover in place and remove the cover. **NOTE:** The two cap screws that pass through the bottom of the component housing also hold the belt tensioner assembly in place.
6. **To replace the drive motor**, remove the screws that secure the diagonal brace to the component housing. Remove the drive belt. Loosen the setscrew securing the motor pulley to the motor shaft and remove the pulley. Hold the replacement motor next to the failed motor and transfer the wiring connections to the replacement. Remove the four screws that secure the motor to the cabinet and install the replacement.

7. **To replace the auxiliary transformer** (present only in 200V and 208V units), hold the replacement next to the failed transformer and, one at a time, disconnect the wires from the failed transformer and connect them to the replacement. When all wiring has been transferred, remove the screws and nuts that secure the transformer to the back wall of the motor compartment and install the replacement.

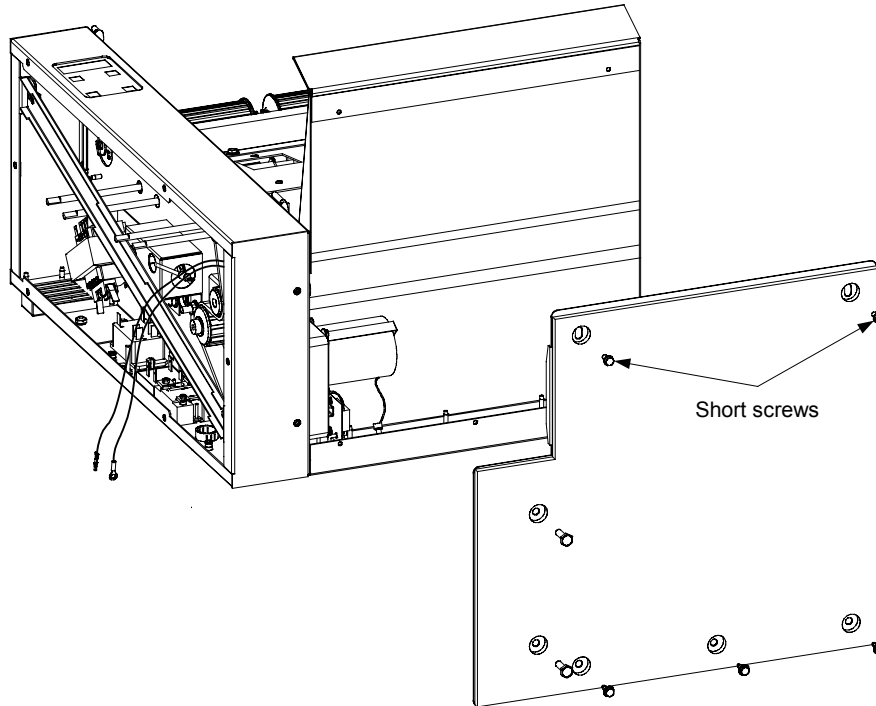

8. Reverse the steps performed to reassemble unit.

Replacing the Dual Belt Conveyor Cartridge Heater

1. Turn off and unplug the unit.
2. Pull the bun compression knobs off their shafts.
3. Remove the screws in the edge of the component housing cover.
4. Disconnect the heater leads. Remove the hex-head screws securing the heater in place and remove the heater (see illustration on Page 1-6).
5. Reverse steps 1-4 to reassemble the unit.

Replacing the Transformer or Relays

1. Turn off and unplug the unit.
2. Pull the bun compression knobs from their shafts.
3. Remove the screws in the edge of the component housing cover.
4. Hold the replacement component next to the component to be replaced and, one at a time, disconnect the wires from the failed component and connect them to the replacement component.
5. Remove the screws and/or nuts securing the failed component to the component housing and install the replacement.
6. Reverse steps 1-3 to reassemble the unit.

1.4 Technician Troubleshooting

PROBLEM	PROBABLE CAUSES	CORRECTIVE ACTION
Display remains blank when unit turned on.	A. Failed transformer.	A. Check for line voltage on the primary (line) side of transformer and 12VAC on secondary (load) side of transformer. If line voltage is present but secondary voltage is not 12VAC, the transformer has failed.
	B. Failed computer.	B. Check continuity between right terminal of secondary (load) side of transformer and Pin 9 of the 9-pin connector when the cover interlock switch is closed. If resistance is zero, replace the computer.
	C. Failed cover interlock switch or failed high limit.	C. Check continuity between switch terminals when the switch is closed. If resistance is infinite, replace switch. If resistance is zero, replace high limit.
Computer display is on, but motor is not running	A. Failed motor.	A. If platen is heating, replace motor.
	B. Broken/loose wire between computer and latch relay or failed latch relay.	B. Check for 12VDC on Pins 6 & 7 of computer. If present and wiring is intact, replace latch relay. If not present, replace computer.
Motor is running at wrong speed (i.e. average time for three individual buns to pass through toaster is NOT between 15 and 18 seconds).	A. Toaster improperly configured for power supply.	A. Check data plate for voltage rating, and verify that power supply and toaster match.
Platen heats, but unit does not reach setpoint.	A. Improper power-supply.	A. Verify that the power supply is 20 amp single-phase 200, 208 or 240VAC (depending upon model).
	B. Failed temperature probe.	B. Use a temperature-measuring device to determine actual platen temperature. If measured temperature is within 10 degrees of the temperature displayed on the computer and the probe resistance at pins 3 and 5 of the 9-pin connector does not correspond to the appropriate value in the probe resistance chart on Pages 24 and 25, replace the probe.
	C. Failed computer.	C. Use a temperature-measuring device to determine actual platen temperature. If measured temperature is within 10 degrees of the temperature displayed on the computer and probe resistance at pins 3 and 5 of the 9-pin connector corresponds to the value in the probe resistance chart on Pages 24 and 25, replace the computer.

PROBLEM	PROBABLE CAUSES	CORRECTIVE ACTION
Platen does not heat, but computer display is on.	A. Failed computer.	A. Check for 12VDC on computer pins 6 & 7. If NOT present AND motor is running, replace computer. Check for 5VDC on terminals 3 & 4 of main heater relay and pins 1 and 6 of computer. If NOT present at either point AND motor is running, replace computer.
	B. Broken/loose wire between computer and latch relay, or failed latch relay.	B. Check for 12VDC on computer pins 6 & 7. If present and wiring is intact, replace latch relay.
	C. Failed main heater probe.	C. Determine temperature of platen then measure main heater probe resistance at pins 3 & 5 of 9-pin connector. If the probe resistance is NOT approximately equal to the corresponding resistance in the chart on Pages 24 and 25, replace the probe.
	D. Broken/loose wire between computer and main heater relay, or failed main heater relay.	D. Check for 5VDC on terminals 3 & 4 of main heater relay AND on computer pins 1 & 6. If present on pins 1 & 6, but NOT on terminals 3 & 4, and wiring is intact, replace the main heater relay.
	E. Failed platen.	E. Check for 5VDC on terminals 3 & 4 of main heater relay and for line voltage on terminal 2 of main heater relay and terminal 4 of latch relay. If expected voltage is present at all three points, replace the platen.

Probe Resistance Chart

For use with CT16 Series toasters manufactured with Minco Thermistor probes only.

F	OHMS	C	F	OHMS	C	F	OHMS	C	F	OHMS	C	F	OHMS	C
60	1059	16	160	1268	71	260	1473	127	360	1674	182	460	1872	238
65	1070	18	165	1278	74	265	1483	129	365	1684	185	465	1882	241
70	1080	21	170	1289	77	270	1493	132	370	1694	188	470	1892	243
75	1091	24	175	1299	79	275	1503	135	375	1704	191	475	1901	246
80	1101	27	180	1309	82	280	1514	138	380	1714	193	480	1911	249
85	1112	29	185	1320	85	285	1524	141	385	1724	196	485	1921	252
90	1122	32	190	1330	88	290	1534	143	390	1734	199	490	1931	254
95	1133	35	195	1340	91	295	1544	146	395	1744	202	495	1940	257
100	1143	38	200	1350	93	300	1554	149	400	1754	204	500	1950	260
105	1154	41	205	1361	96	305	1564	152	405	1764	207	505	1960	263
110	1164	43	210	1371	99	310	1574	154	410	1774	210	510	1969	266
115	1174	46	215	1381	102	315	1584	157	415	1783	213	515	1979	268
120	1185	49	220	1391	104	320	1594	160	420	1793	216	520	1989	271
125	1195	52	225	1402	107	325	1604	163	425	1803	218	525	1998	274
130	1204	54	230	1412	110	330	1614	166	430	1813	221	530	2008	277
135	1216	57	235	1422	113	335	1624	168	435	1823	224	535	2018	279
140	1226	60	240	1432	116	340	1634	171	440	1833	227	540	2029	282
145	1237	63	245	1442	118	345	1644	174	445	1843	229	545	2039	286
150	1247	66	250	1453	121	350	1654	177	450	1852	232	550	2049	288
155	1258	68	255	1463	124	355	1664	179	455	1862	235			

1.5 Wiring Diagrams

NOTE: These diagrams depict wiring as of the date of manual publication. They may not reflect design changes made to the equipment after publication. Always refer to the wiring diagram affixed to the unit when actually troubleshooting or servicing this equipment.

NON-CE TOASTERS

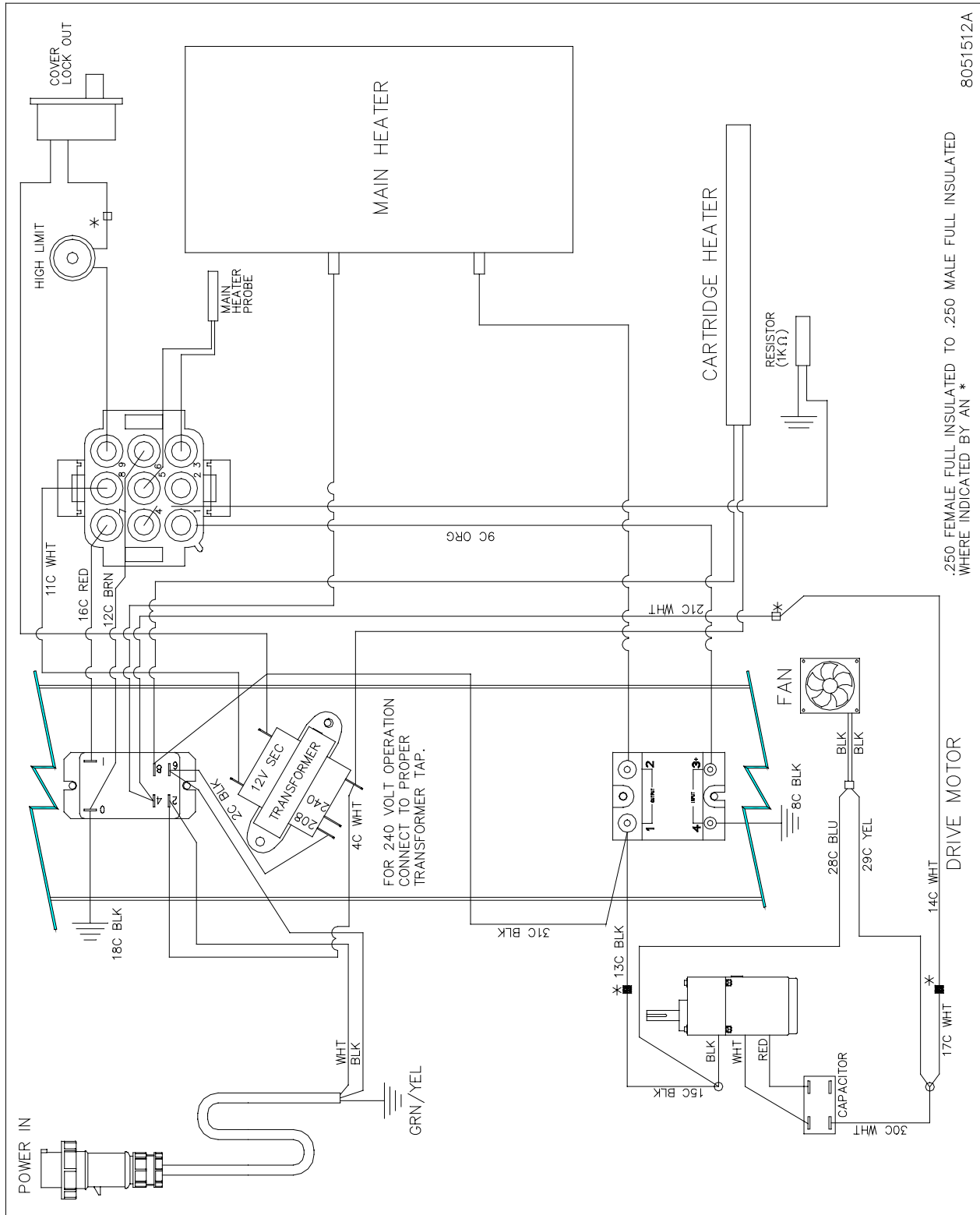

CE AND AUSTRALIAN TOASTERS

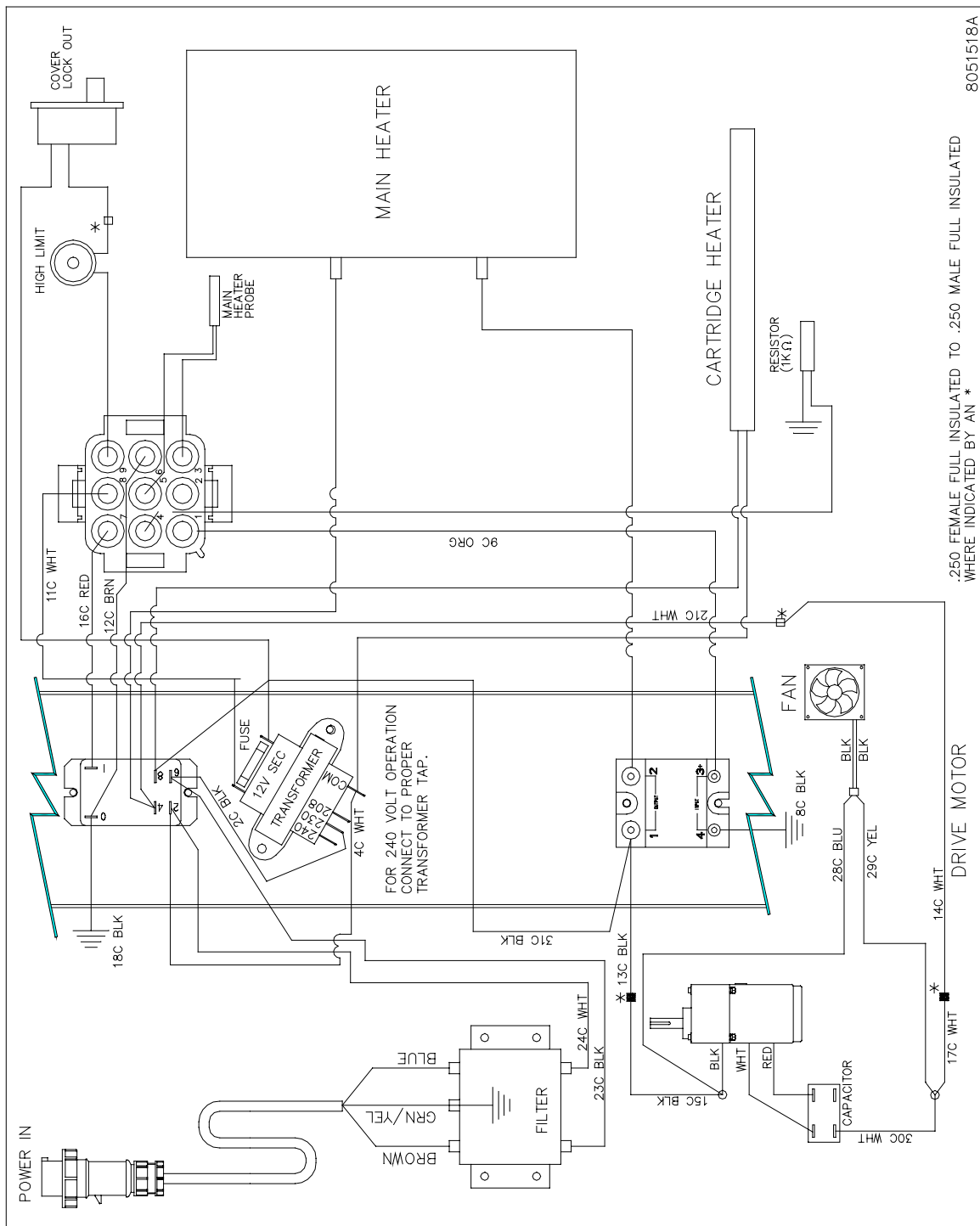

8051518A

.250 FEMALE FULL INSULATED TO .250 MALE FULL INSULATED WHERE INDICATED BY AN *

1.6 Schematic

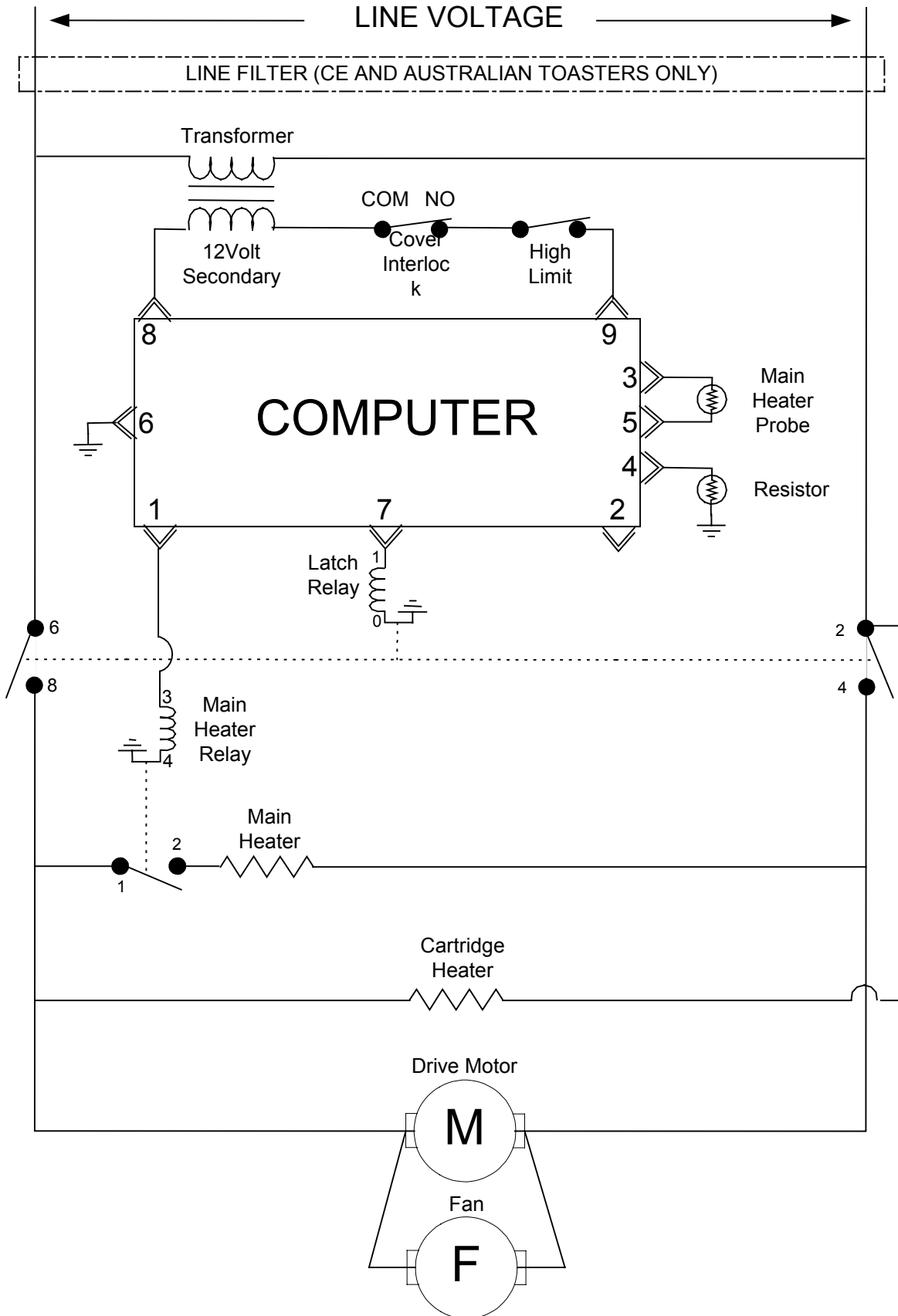

THIS PAGE INTENTIONALLY LEFT BLANK.

CT16 SERIES TOASTER SERVICE AND PARTS MANUAL CHAPTER 2: PARTS LIST

2.1 Introduction

CT16 Toasters manufactured for use in the European Union (CE) and those manufactured for use elsewhere are identical in most respects, but there are some important differences. The paragraphs that follow summarize the differences and provide a list of the parts that are unique to each model.

The most significant differences are in the electronic components. Units built for the CE and Australian markets have a 50 Hz motor; all others have a 60 Hz motor. Non-CE and CE/Australian units also use different transformers, and CE/Australian units have a line filter built into the electrical power supply system. The line filter and cover are attached to the rear of the cabinet.

Because of the difference in the power cycle frequency (50 Hz vs. 60 Hz), CE and Australian units are equipped with 10-tooth drive pulleys and a 28-Tooth motor pulley. Standard units have 17-tooth drive pulleys and an 18-tooth motor pulley. The different pulleys on the CE and Australian units maintain the correct belt speed even though the RPM of the motor at 50 Hz is slightly slower than that of the motor at 60 Hz.

The table below identifies the components that are unique to each configuration.

Components Unique to CE and Australian Units		Components Unique to Non-CE Units	
P/N	Description	P/N	Description
807-2191	Transformer (208-240V/12V)	807-0979	Transformer (208-240V/12V)
807-0910	Transformer Fuse, 250V/3A	N/A	Not used.
106-0781	Transformer and Bracket Assembly	N/A	Not used.
807-3472	Line Filter	N/A	Not used.
824-0896	Line Filter Cover	N/A	Not used.
106-2143	Tensioner Assembly, Drive Belt	106-2723	Tensioner Assembly, Drive Belt
810-2300	28-Tooth Motor Driven Pulley	810-2565	18-Tooth Motor Driven Pulley
810-2301	10-Tooth Dual Belt Drive Pulley	810-2566	17-Tooth Dual Belt Drive Pulley
810-2332	10-Tooth Toasting Belt Drive Pulley	810-2564	17-Tooth Toasting Belt Drive Pulley

The illustrations in the parts list that follows also identify the CE/Australian and Non-CE components.

2.2 Cabinetry

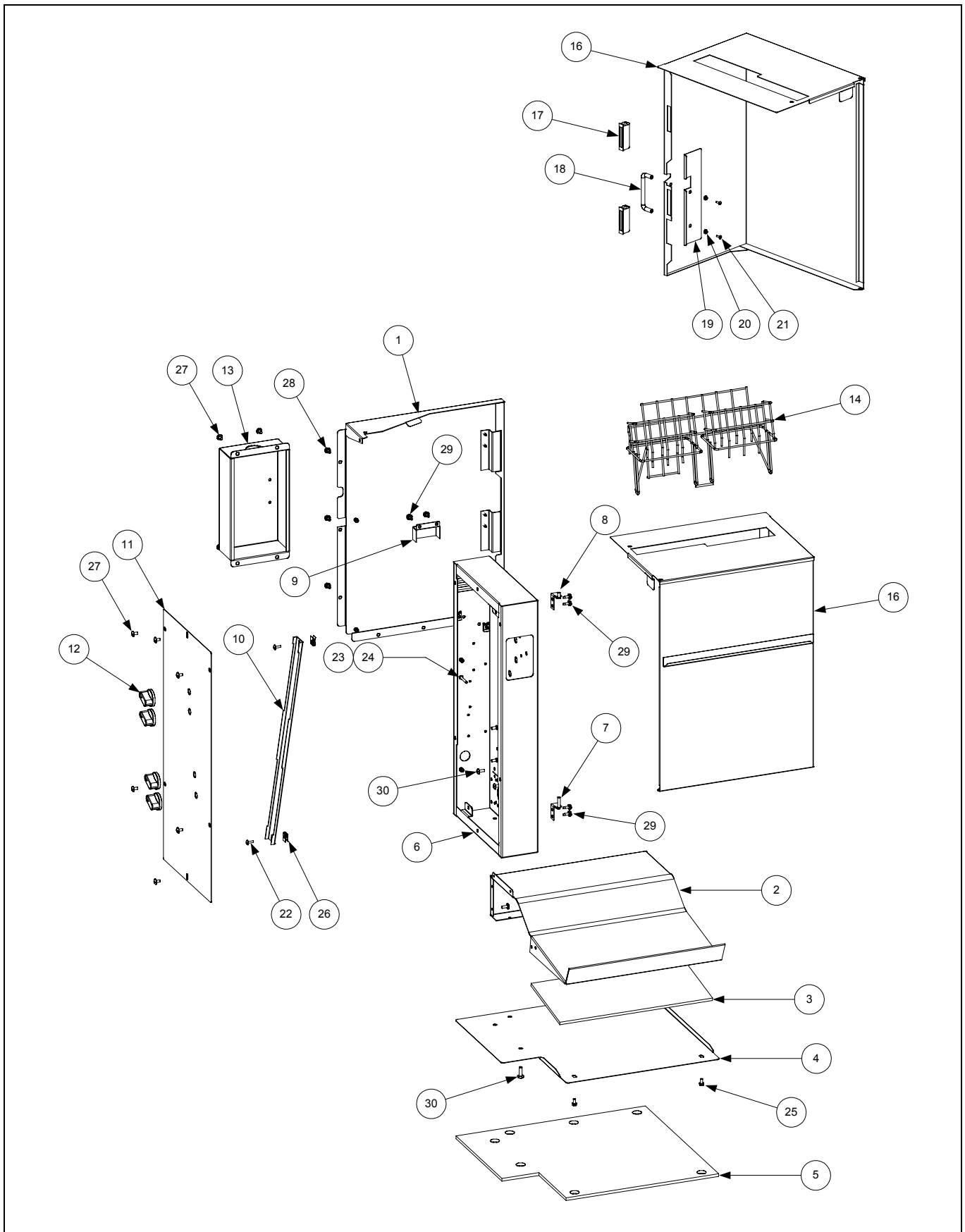

ITEM	PART #	COMPONENT
1	106-2720SP	Back Cover Assembly
2	824-1117	Tray Assembly, Toast
3	816-0573	Insulation, Toast Tray
4	200-4270	Bottom, Toaster
5	816-0589	Seal, Toaster Base
6	823-3988	Housing, Component
7	210-5311	Bracket, Lower Hinge
8	823-2941	Bracket, Upper Hinge
9	210-3434	Cover, Air Inlet
10	200-2877	Brace, Component Housing
11	210-2876	Cover, Component Housing
12	810-2331	Knob, Compression Adjustment
13	106-0785SP	Cover, Line Filter (used on CE and Australian units only)
14	810-2549	Guide, Bread (Wireform Feeder)
15	106-2158	Cover Assembly, Toaster (includes Items 16-21)
16	823-3656	Cover (does not include Items 17-21)
17	810-0066	Magnet
18	810-1683	Handle, Cover
19	910-9458	Reinforcement, Cover Side
20	809-0184	Washer, #10 Lock
21	809-0107	Screw, 8-32 x $\frac{3}{8}$ -inch Slotted Round Head
22	809-0104	Screw, 8-32 x $\frac{1}{2}$ -inch Slotted Truss Head
23	809-0112	Screw, 8-32 x 1 $\frac{1}{4}$ -inch Slotted Truss Head
24	809-0247	Nut, 8-32 Hex
25	809-0434	Screw, #10 x $\frac{3}{8}$ -inch Hex Washer Head
26	809-0448	Clip, Tinnerman
27	826-1330	Screw, 10-32 x $\frac{3}{8}$ -inch Slotted Truss Head (Pkg. of 25)
28	826-1374	Screw, #10 x $\frac{1}{2}$ -inch Hex Head (Pkg. of 25)
29	826-1379	Screw, #10 x $\frac{1}{2}$ -inch Philips Truss Head (Pkg. of 10)
30	826-1389	Screw, $\frac{1}{4}$ -20 x $\frac{3}{4}$ -inch Hex Head (Pkg. of 10)
*	810-1712	Clip, Adhesive-backed Wire Routing

* Not illustrated

2.3 Conveyor Assembly, Dual Belt

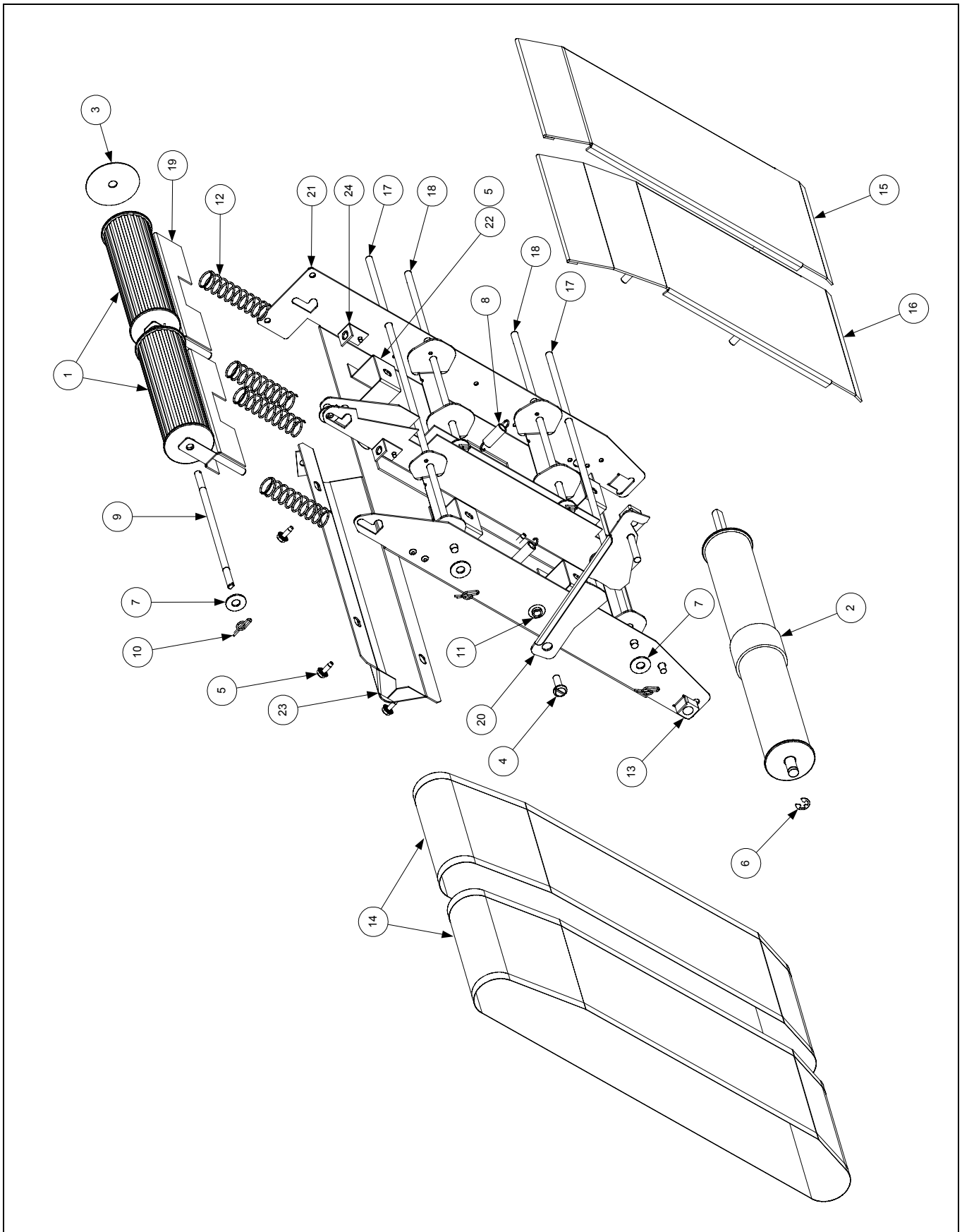

ITEM	PART #	COMPONENT
1	806-9200	Roller Assembly, Dual Belt Idler
2	806-9318	Roller Assembly, Dual Belt Drive
3	810-2303	Washer, Teflon Crumb
4	809-0132	Screw, 1/4-20 x 3/4-inch Slotted Pan Head
5	826-1374	Screw, #10 x 1/2-inch Hex Head (Pkg. of 25)
6	809-0647	E-Ring
7	809-0745	Washer, 1/4-inch Flat
8	810-1672	Spring, Compression Plate
9	810-1718	Shaft, Short Dual Belt Roller
10	810-1776	Pin, VT Cotter
11	810-1802	Bushing, Tray Stabilizer Latch Support
12	810-1818	Spring, 3.00-inch Long, 4.6 Lbs./Inch
13	810-2305	Bushing
14	816-0389	Belt, Dual Conveyor
15	823-2719	Plate Assembly, VT Right Pressure
16	823-3578	Plate Assembly, VT Left Pressure
17	823-2722	Cam Assembly, VT Long
18	823-2723	Cam Assembly, VT Short
19	823-2798	Cover Assembly, VT Spring
20	823-2838	Latch Assembly, VT Tray
21	823-3989	Tray Assembly, Dual Belt
22	900-8155	Bracket, Guide Rod
23	910-8254	Brace, Dual Belt Tray
24	910-8512	Bracket, Spring Guide Receiver
25	210-4245	Bracket, Left Center Support
26	210-4246	Bracket, Right Center Support

2.4 Conveyor Assembly, Toasting

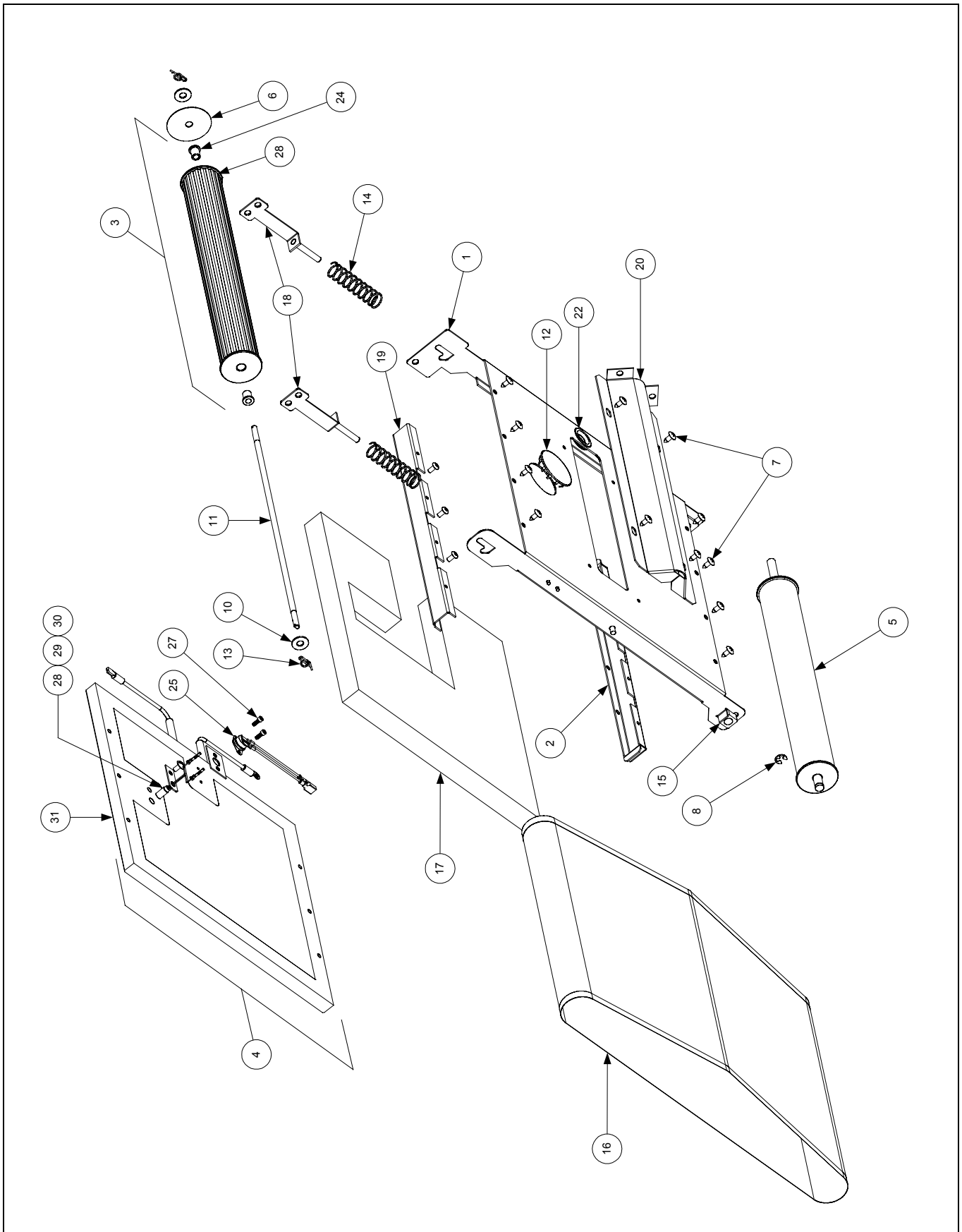

ITEM	PART #	COMPONENT
1	106-2123SP	Tray with Grommet, VT Platen
2	210-0318	Crumb Shield, Toasting Conveyor
3	806-9195	Roller, VT Toasting Belt Idler
4	806-9196SP	Platen Assembly, VT
5	806-9199	Roller, VT Toasting Belt Drive
6	810-2303	Washer, Teflon Crumb
7	809-0266	Screw, #10 x 1/2-inch Philips Truss Head
8	809-0647	E-Ring
9	809-0650	Screw, 10-32 x 3/8-inch Button Socket Head
10	809-0745	Washer, 1/4-inch Flat
11	810-1721	Shaft, Long Roller
12	810-1736	Plug, 1.75-inch Stainless Button
13	810-1776	Pin, VT Cotter
14	810-1818	Spring, 3-inches Long, 4.6 Lbs./Inch
15	810-2305	Bushing, Roller
16	816-0379	Belt, Toasting
17	816-0403	Insulation, Platen
18	823-2726	Slide Assembly, Belt Tension
19	910-8246	Guide, Crumb Shield
20	910-8254	Brace, VT Platen Tray
21*	910-8512	Bracket, Slide Assembly Receiver
22	810-1722	Grommet, .5-inch I.D. x 1.05-inch O.D. (Integral component of Item 1)
23	810-2013	Roller, VT Drive (Integral component of Item 3)
24	810-1810	Bushing, Teflon (Integral component of Item 3)
25	807-3037	Thermostat, High-Limit (Integral component of Item 4)
26	910-8637	Spacer, High-Limit Thermostat (Integral component of Item 4)
27	809-0729	Capscrew, 6-32 x 1/4-inch Socket Head (Integral component of Item 4)
28	807-3247	Probe, Heater (Integral component of Item 4)
29	910-8757	Retainer, Heater Probe (Integral component of Item 4)
30	826-1330	Screw, 10-32 x 3/8-inch Slotted Truss Head (Integral component of Item 4)
31	810-1658	Platen, 5000W (Integral component of Item 4)

* Obscured by Item 1. See Item 24 on Page 5 for illustration.

2.5 Electronic Components

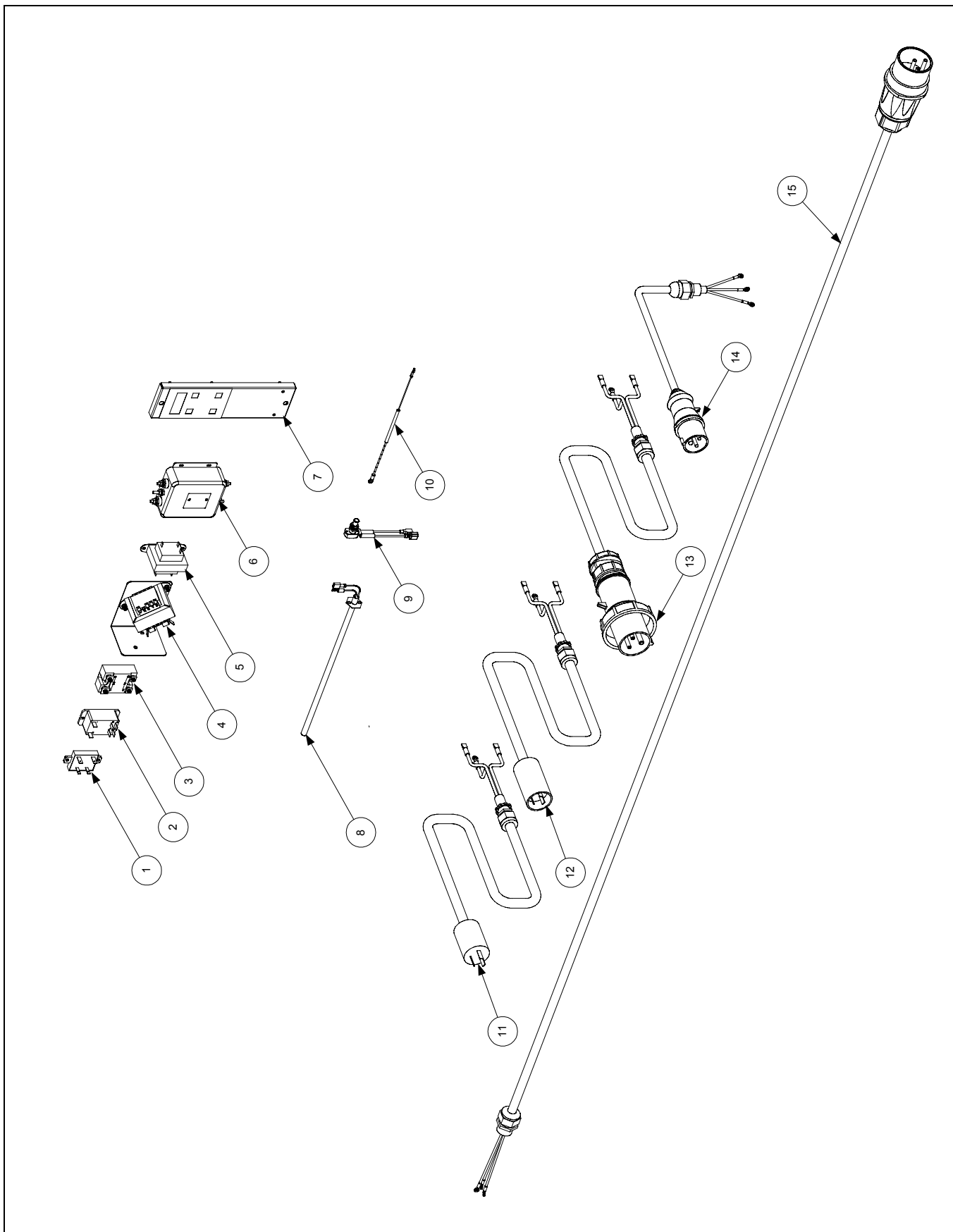

ITEM	PART #	COMPONENT
1	807-3213	Relay, Solid State 5A 3/16 Control Terminals
2	807-3021	Relay, 30A 12VDC DPST NO
3	826-1562	Relay, Solid State 40A 280V SPST NO
4	106-0781SP	Transformer and Bracket Assembly, CE and Australian
*	807-0910	Fuse, 250V 3A (fuse for CE/Australian transformer)
5	807-0979	Transformer, 208-240VAC/12VAC, 50/60 Hz, 43VA, Non-CE
7	806-9296	Computer Assembly, VT
8	807-3196	Heater, 240V 165W Cartridge
9	807-3064	Switch, Cover Interlock
10	806-9796	Resistor Assembly, Holding Tray
11	807-3243	Cordset, Standard Twist-Lock
12	807-3198	Cordset, Hooded Twist-Lock
13	807-3242	Cordset, Pin and Sleeve
14	807-3529	Cordset, CE VT
15	807-3850	Cordset, Australian VT

*Not illustrated.

2.6 Motor, Drive Train, and Fan Components

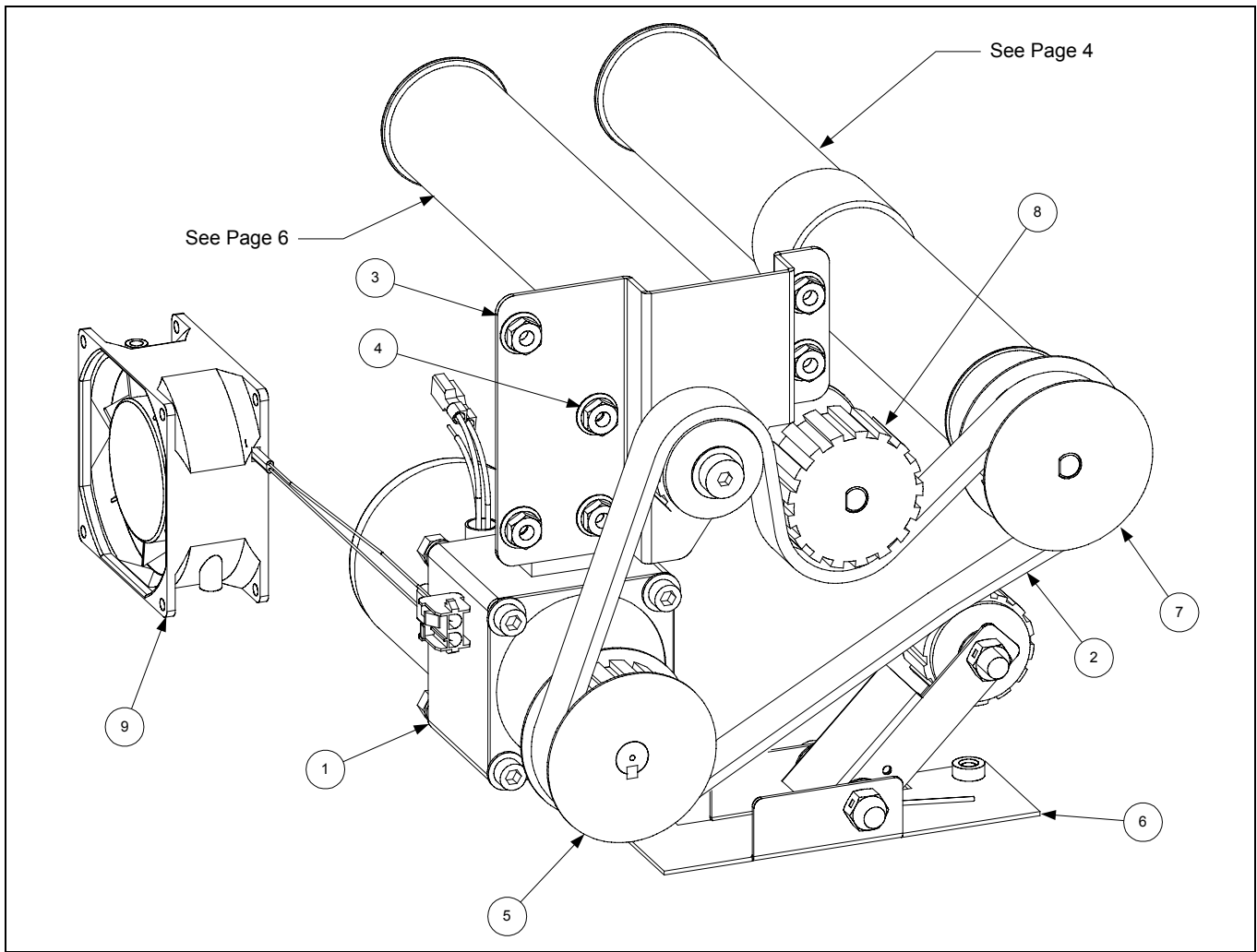

ITEM	PART #	COMPONENT
1		Motor Assembly, 50/60 Hz
	106-3052	200-208V VT Drive
	106-2841	220-250V VT Drive
2	810-2302	Drive Belt
3	106-2128	Bracket Assembly, VT Idler Pulley
4	826-1368	Nut, 1/4-20 Serrated Flange (Pkg. of 10)
5		Pulley, Motor Driven
	810-2565	18-Tooth (Non-CE)
	810-2704	21-Tooth (CE and Australian)
6	106-2723	Tensioner Assembly, Drive Belt
7	810-2566	Pulley, 17-Tooth Dual Belt Drive
8	810-2564	Pulley, 17-Tooth Toasting Belt Drive
9	106-2703	Fan Assembly, VT Motor Cooling

THIS PAGE INTENTIONALLY LEFT BLANK.



Frymaster, L.L.C., 8700 Line Avenue, PO Box 51000, Shreveport, Louisiana 71135-1000
Shipping Address: 8700 Line Avenue, Shreveport, Louisiana 71106

TEL 1-318-865-1711 FAX (Parts) 1-318-688-2200 FAX (Tech Support) 1-318-219-7135

PRINTED IN THE UNITED STATES

SERVICE HOTLINE
1-800-551-8633

819-5993
JANUARY 2004

Free Manuals Download Website

<http://myh66.com>

<http://usermanuals.us>

<http://www.somanuals.com>

<http://www.4manuals.cc>

<http://www.manual-lib.com>

<http://www.404manual.com>

<http://www.luxmanual.com>

<http://aubethermostatmanual.com>

Golf course search by state

<http://golfingnear.com>

Email search by domain

<http://emailbydomain.com>

Auto manuals search

<http://auto.somanuals.com>

TV manuals search

<http://tv.somanuals.com>