



nexia

270 *ix* Z **MRC**

23-50mm AUTOFOCUS ZOOM CAMERA

Owner's Manual



CERTIFIED PHOTOFINISHING SERVICE

- Have your film processed by a Photo Finisher which displays the above sign.
- Different Photo Finishers may provide different services.
Consult them for details of their services.



The "CE" mark certifies that this product satisfies the requirements of the EU (European Union) regarding safety, public health, environment and consumer protection. ("CE" is the abbreviation of Conformité Européenne.)
This product conforms with Directive 89/336/EEC.



CONTENTS

FEATURES	2
PART NAMES	3

1. PRELIMINARY STEPS

ATTACHING THE STRAP	5
LOADING THE BATTERY	6
POWER ON/OFF	7
SETTING AND CORRECTING THE DATE (YEAR : MONTH : DAY/HOUR : MINUTE)	8
SELECTING THE DATE MODE	10

2. BASIC PROCEDURES

LOADING THE FILM CARTRIDGE	11
SELECTING THE PRINT FORMAT	14
TAKING PICTURES	17
USING THE AUTO-FOCUS LOCK	21
UNLOADING THE FILM CARTRIDGE	23
CARTRIDGE MID-ROLL CHANGE FUNCTION	25

3. ADVANCED TECHNIQUES

SELECTING THE EXPOSURE MODE	29
THE "USER TITLE" SELECTION	35
CHANGING THE "USER TITLE" SELECTION	38

PRINT QUANTITY	39
CHANGING THE PRINT QUANTITY	42
USING THE SELF-TIMER	43
MULTI PROGRAM FLASH	45
CAMERA CARE AND CAUTIONS	47
ERRORS, POSSIBLE CAUSES, AND REMEDIES ..	49
SPECIFICATIONS	52
LIST OF AVAILABLE TITLES	54

FEATURES

- 23 – 50 mm Autofocus Zoom
- Mid-Roll Change
- Super EBC Fujinon Lens
- Multi-Programmed Retractable Flash
- Error-Free Drop-in Loading
- 3 Selectable Prints Formats
- User Select Title with Language Selection
- Print Quantity Pre-Setting Capability
- Print Quality Enhancement Through Information Exchange System
- Red Eye Reduction
- Film Safety Lock

PART NAMES

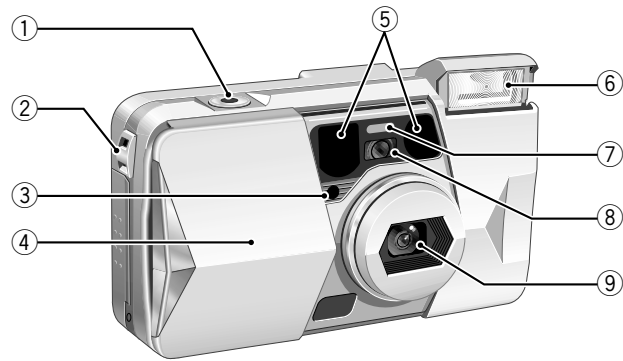

- ① Shutter Release Button
- ② Strap Lug
- ③ AE Light Sensor
- ④ Slide Cover
- ⑤ AF (Autofocus) Window
- ⑥ Flash
- ⑦ Self-Timer Lamp
- ⑧ Viewfinder Window
- ⑨ Super EBC Fujinon Lens

(See the illustrations while you read this manual.)

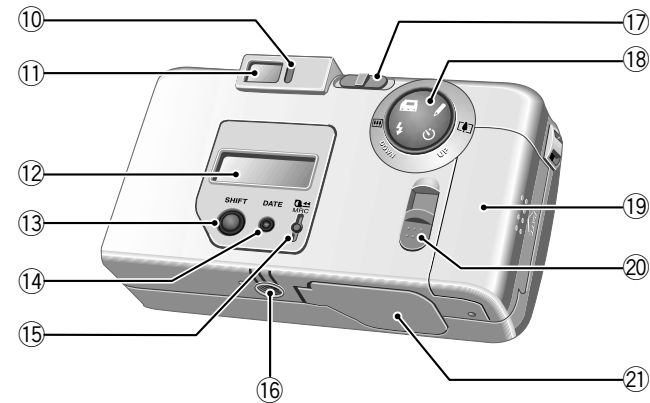

- ⑩ AF Lamp
- ⑪ Viewfinder Eye-piece
- ⑫ Liquid Crystal Display
- ⑬ SHIFT Button
- ⑭ DATE Button
- ⑮ Mid-Roll Change Button
- ⑯ Tripod Socket
- ⑰ Format Selector
- ⑱ Multi-Operation Button
- ⑲ Battery Compartment Cover
- ⑳ Film Cartridge Compartment Cover Release Knob
- ㉑ Film Cartridge Compartment Cover

Multi-operation button

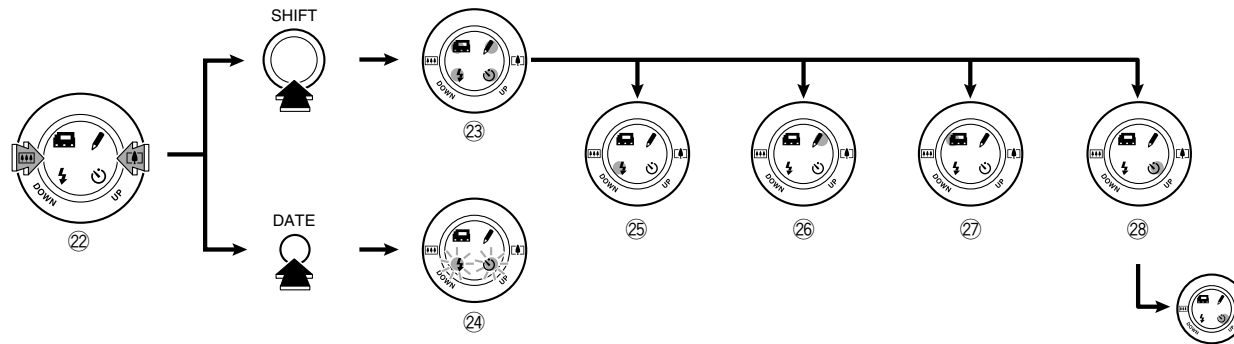

Multi-Operation Button

A multi-function button that enables the selection and setting of all modes. It is usually used as the zoom button, but the functions for the various modes can be selected when it is used in combination with the SHIFT/DATE button.

- ②② Zoom Mode
- ②③ Mode Selection
- ②④ Date Correction Mode
- ②⑤ Exposure Mode
- ②⑥ Title Selection
- ②⑦ Print Quantity
- ②⑧ Self-Timer Mode

- * Refer to the relevant sections for further details.
- * The zoom function may not be used during mode selection.

Liquid crystal display

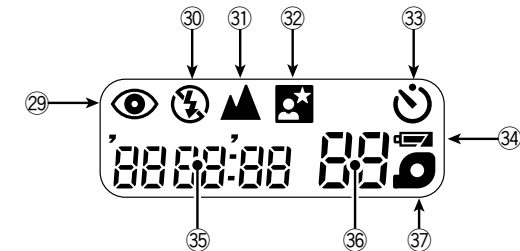

Liquid Crystal Display

The diagram shows all crystal displays in the “on” state.

- ②⑨ Red-eye Reduction Flash Mode
- ③⑩ Fill-in Flash Mode/Flash off Mode
- ③① Landscape Mode
- ③② Night Portrait Mode
- ③③ Self-Timer Mode
- ③④ Battery Capacity
- ③⑤ Date Display (Also serving as User Title Selection/Print Quantity/Type of Film Cartridge/Camera ISO Display)
- ③⑥ Exposure Counter/Self-timer Count
- ③⑦ Film Cartridge Mark

1. PRELIMINARY STEPS

ATTACHING THE STRAP

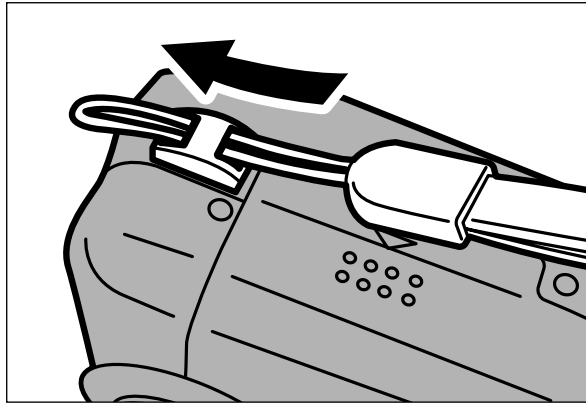

Fig. 1

Pass the smaller loop end of the strap through the camera's strap lug.

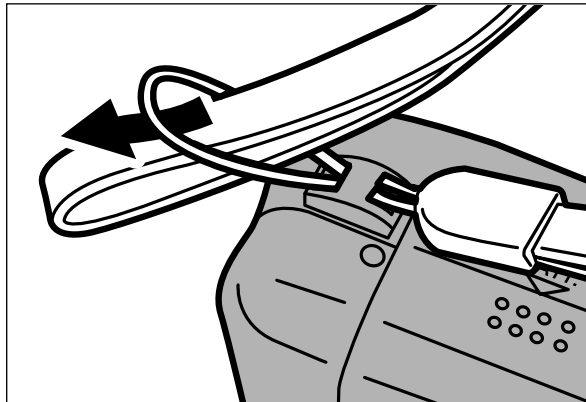

Fig. 2

Next, pass the longer loop end of the strap through the smaller loop, and pull the longer loop end.

* When using a commercial strap, check the strength and other properties of the strap. Because straps for cellular telephones, PHS, etc. are for light devices, be especially careful when using them.

LOADING THE BATTERY

Use the following lithium battery.

★ CR123A/DL123A 3V (one)

- * One lithium battery has enough power for taking approximately 300 shots (Based on our test conditions).
- * If many rolls of film are used, when travelling, for example, it is desirable to take spare batteries (particular in areas where it may be difficult to obtain batteries).
- * Do not load the cartridge before inserting the battery.

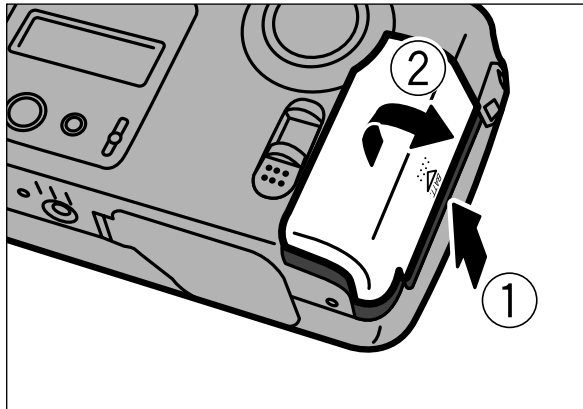

Fig. 3

Slide the battery compartment cover toward the arrow ①, then open the cover in the direction of the arrow ②.

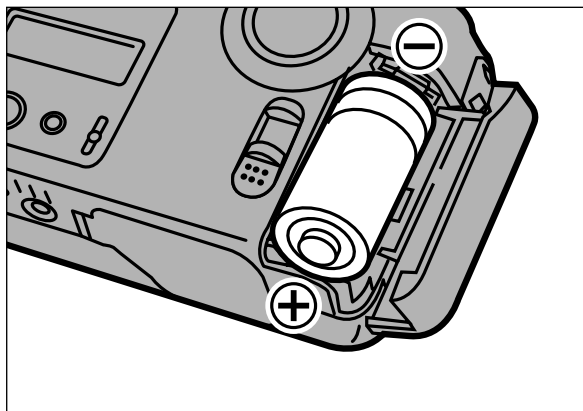

Fig. 4

Insert the (-) side of the battery first then the (+) side according to the sign, then close the battery compartment cover.

- * After changing the battery, be sure to set the date again. (The method for setting the date is shown on Fig.8.)

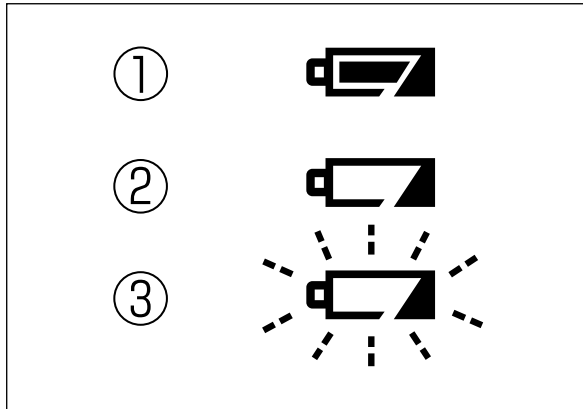

Fig. 5

Check the battery capacity sign on the LCD.

- ① on: Battery capacity is OK.
- ② on: Battery capacity is insufficient; provide a new battery.
- ③ blink: Shutter release will not trip because the battery has no charge; change the battery.

* Check the battery capacity sign before using the camera.

* The battery can be replaced even when there is a film cartridge in the camera.

POWER ON/OFF

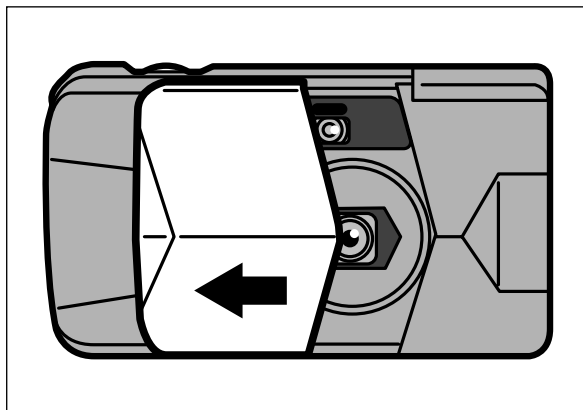

Fig. 6

Slide the slide cover all of the way in the direction of the arrow to switch on the power.

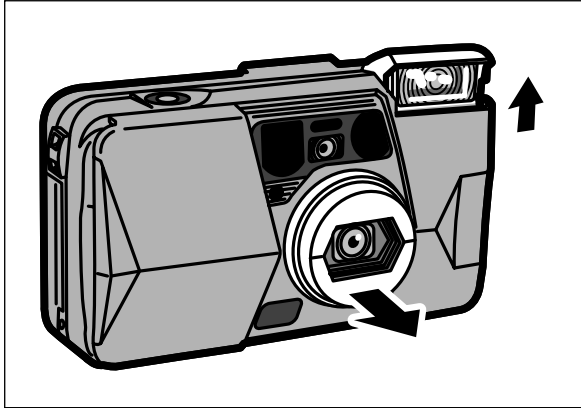

Fig. 7

The lens assembly will slide out and be set in a position to enable exposure. Close the slide cover to switch off the power.

- * If the camera is left to stand for approximately 5 minutes with the slide cover open, the lens assembly will automatically be retracted and the power will be switched off. Close the slide cover and then open it again to enable exposure.
- * The camera may be damaged if the slide cover is closed before the lens assembly has been fully retracted.

SETTING AND CORRECTING THE DATE (YEAR:MONTH:DAY/HOUR:MINUTE)

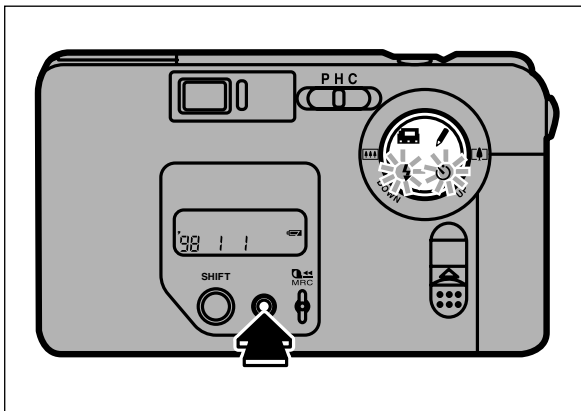

Fig. 8

Switch on the power and press the DATE button for 2 or more consecutive seconds. The UP and DOWN guide lamps will blink and the camera will enter the date correction mode. Continue to press the DATE button to select the blinking numeral in the sequence of year → month → day → hour → minutes.

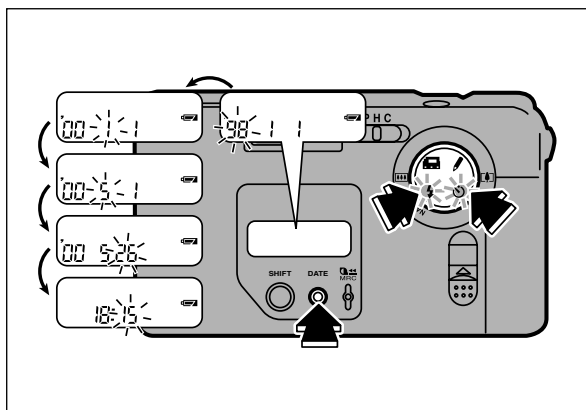

Fig. 9

Press the multi-operation button's UP or DOWN button to correct the numeral blinking on the LCD. Adjustable items are as follows.

Year : '98 – '28 (1998 – 2028)
 Month : 1 – 12 Day : 1 – 31
 Hour : 0 – 23 Minute : 00 – 59

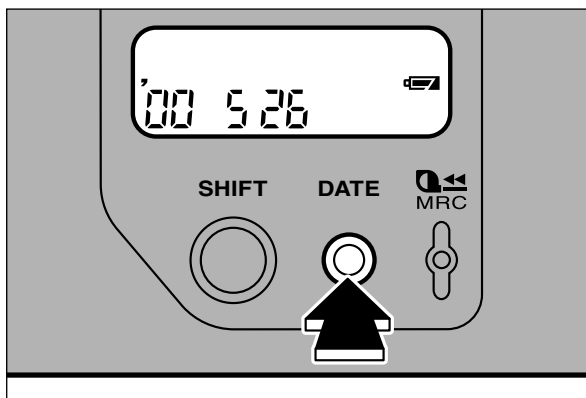

Fig. 10

Press the DATE button after correcting the year, month, day, hour and minutes to extinguish the guide lamp and complete the date correction procedure.

- * To set the hour or minute by the radio, press the DATE button when the time signal announces zero.
- * The year, month, and day change together with the hour and minute.

SELECTING THE DATE MODE

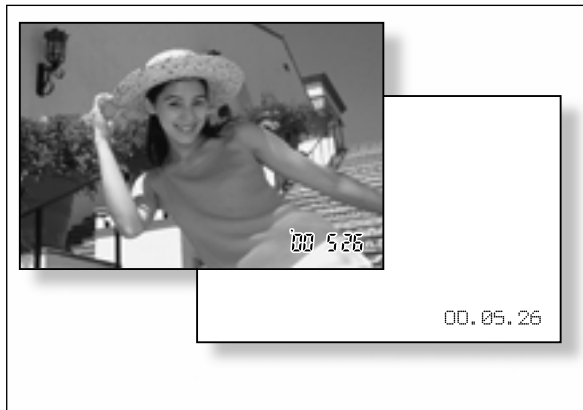

Fig. 11

With the Advanced Photo System

The date (year:month:day/hour:minute) can be printed on the front and back of the print. Frontprinting, which can be seen when inserted in an album, and backprinting, which is convenient for cataloging. Either can be used depending on the purpose.

- * Some photo finishers may not support the feature for printing on the surface.
- * Changes, such as eliminating the date, are possible when re-printing. (Some photo finisher's may not support this feature.)

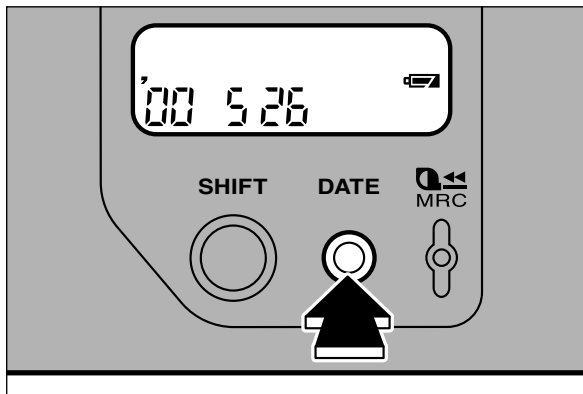

Fig. 12

Switch on the power and press the DATE button to enable selection of the date mode. The mode display will be recorded during exposure and printed during processing.

- * With some backgrounds, the date display on the front may be difficult to see.
- * The front print surface will not be printed when "-- -- --" is displayed. The date [year, month, day] will be printed on the rear surface.

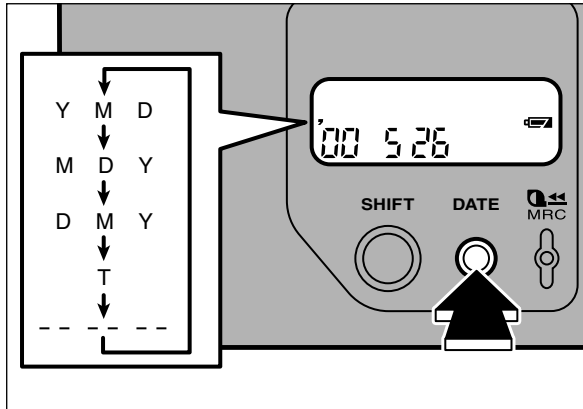

Fig. 13

The date mode will alternate as shown in the diagram whenever the DATE button is pressed.

- * The date mode will be displayed in the [year, month, day] sequence when the date is realigned even when a date mode other than [year, month, day] has been selected. Select the date mode every time the date has been realigned if a setting other than [year, month, day] is required.
(Y : Year M : Month D : Day T : Time)

2. BASIC PROCEDURES

LOADING THE FILM CARTRIDGE

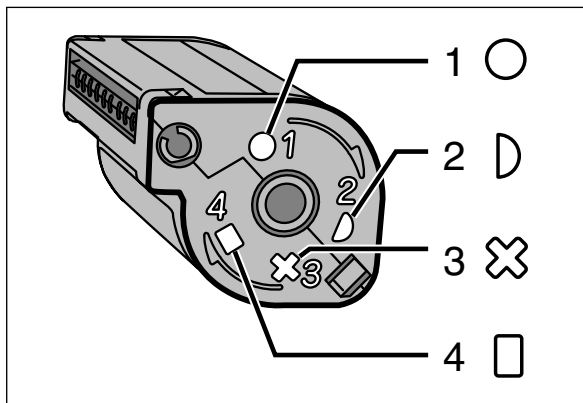

Fig. 14

With the Advanced Photo System



IX240 cartridge film is used.

- * Confirm that the ○ sign or D sign on the film cartridge is white. Cartridges in which the ✕ and □ signs are white cannot be used. (Optical double exposure prevention.)
(1 unexposed 2 partial 3 exposed 4 processed)



Fig. 15

Make sure that the film cartridge mark “” is not displayed in area ① of the LCD.

- * If “” and “” are lit on the LCD, your camera contains a film cartridge already exposed. Remove the film cartridge, following the instructions on Fig. 34 – 36.

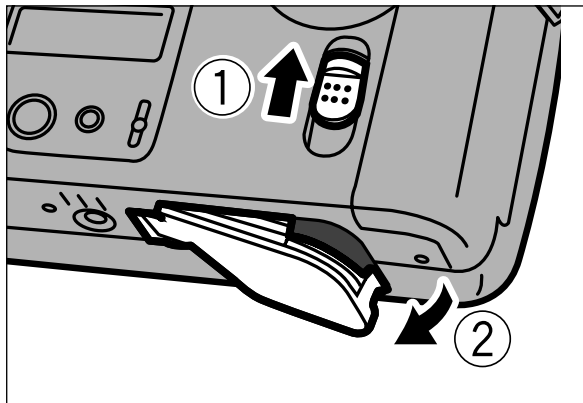

Fig. 16

Move the cartridge cover released knob in the direction of ① and open the cartridge cover slightly. Open the cartridge cover in the direction of ②.

- * Do not apply unnecessary force to the film cartridge compartment cover.

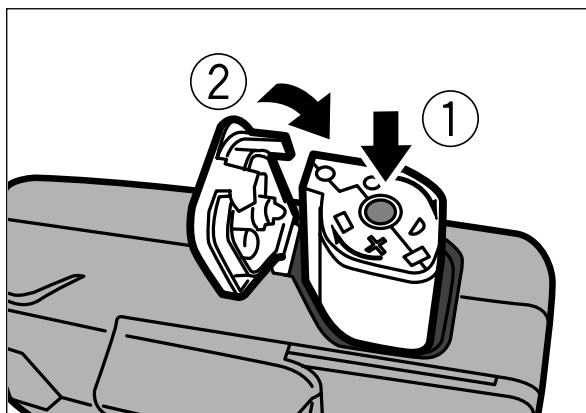

Fig. 17

Drop the cartridge ① into place and then close the cartridge cover ②.

* Insert the battery before inserting the film cartridge.

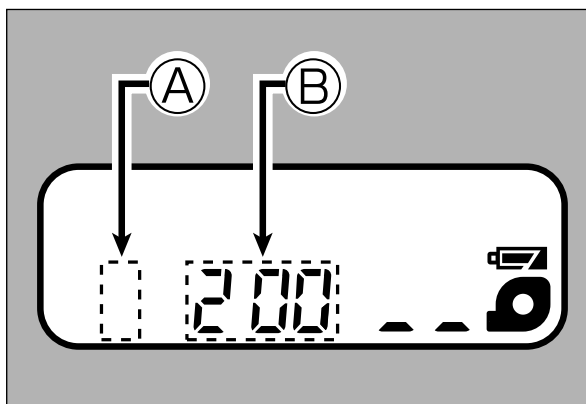



Fig. 18

When the film cartridge compartment cover is closed, the film is automatically advanced and “” is displayed on the LCD. While the film is being advanced to the first frame, the film type and speed are displayed.

(A : Film type)

(B : Film speed)

Type of film cartridge

Color Negative	Positive	Black and White	Other
No display	<i>P</i>	<i>b</i>	<i>o</i>



Fig. 19

When the first frame of the film is set, the usable number of frames (the number of frames specified on the film cartridge) is displayed in the exposure counter.

* The number indicated in the exposure counter decreases by one each time a picture is taken.

SELECTING THE PRINT FORMAT

With the Advanced Photo System

3 print formats - P, H and C can be chosen. Use the format selector to select the format you want.

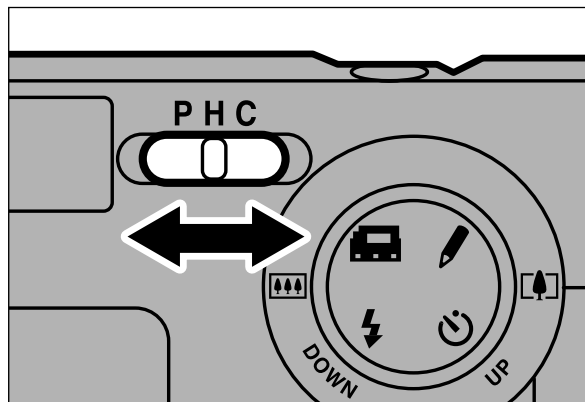

Fig. 20

Select the print format with the format selector located on the rear of the camera.

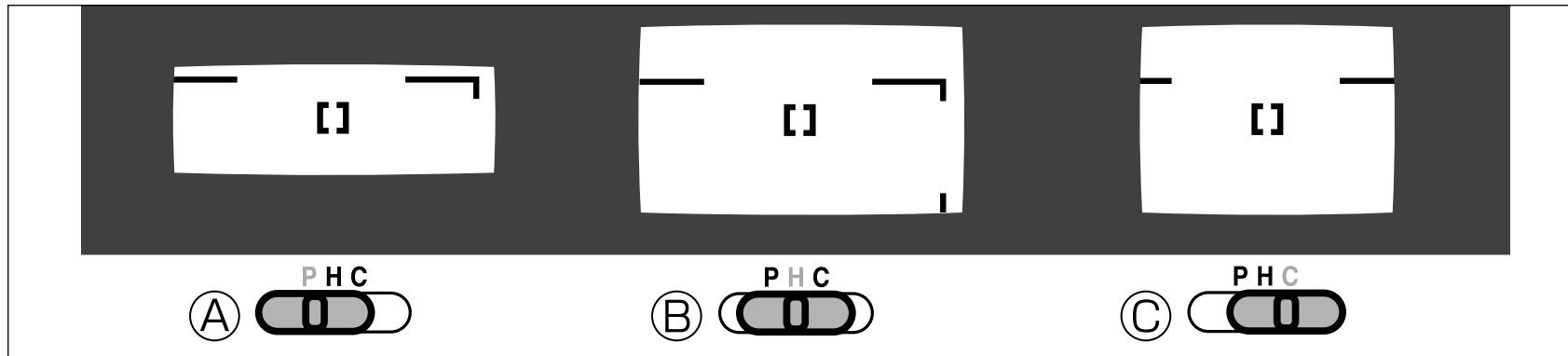

Fig. 21

The view through the finder will change to the style of photographs shown when the format selector is operated. The angle of the exposure will not change.

- Ⓐ : P Print (1 : 3)
- Ⓑ : H Print (9 : 16)
- Ⓒ : C Print (2 : 3)

* Figures in () represent the aspect ratio.

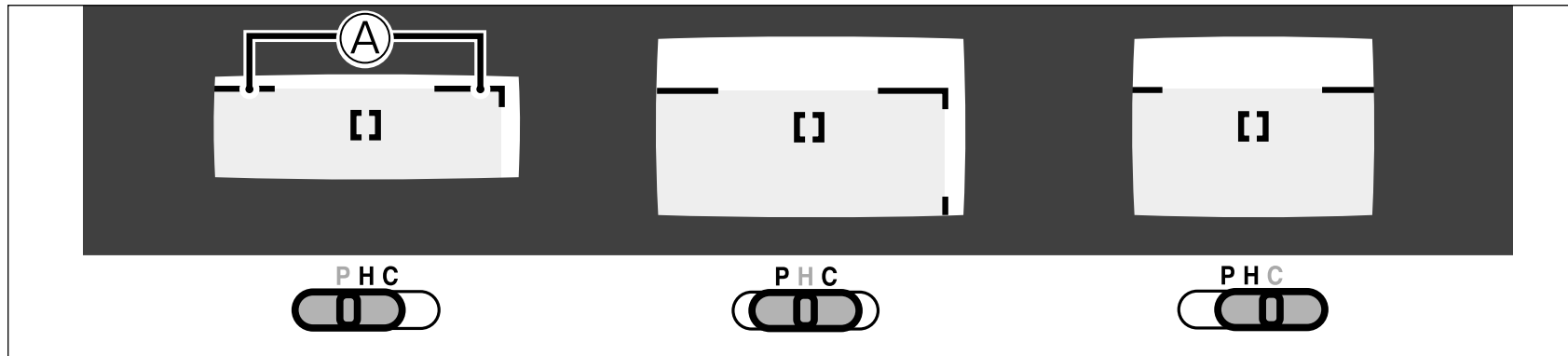



Fig. 22

● **With the close-up picture**

The area visible in the  part shown will be printed when an exposure closer than approximately 1.5 m is taken.

* When taking close ups, the area seen through the viewfinder and the area actually photographed will be different. (Because the viewfinder and the lens are in different locations.) The parallax correction mark is the criteria for the difference between the area seen through the viewfinder and the area actually photographed.

(Ⓐ : Parallax correction mark)

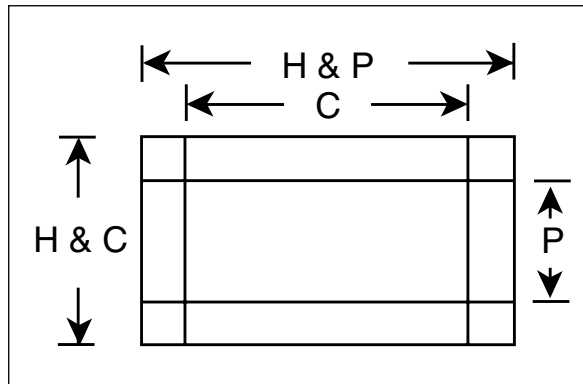

Fig. 23

Even when anyone of the P/H/C print format has been selected, the size of the photograph on the film remains the same (16.7 x 30.2 mm). Print format selection will record the print format for each frame and the exposure will be printed within the ranges shown in the above illustrations.

* The print format can be changed when reprinting.

P	H	C
about 10 x 28 mm	about 16 x 28 mm	about 16 x 23 mm

TAKING PICTURES

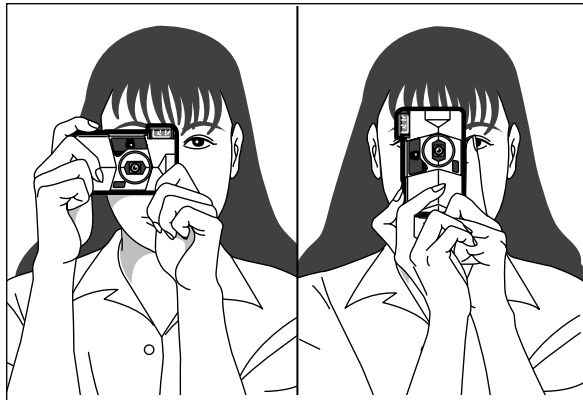

Fig. 24

Open the slide cover to switch on the power, and then hold the camera firmly with both hands. When holding vertically, keep the flash lamp upward.

Take a test exposure prior to taking important photographs (weddings, overseas travel, business-related, etc.,) to ensure that the camera is functioning correctly.

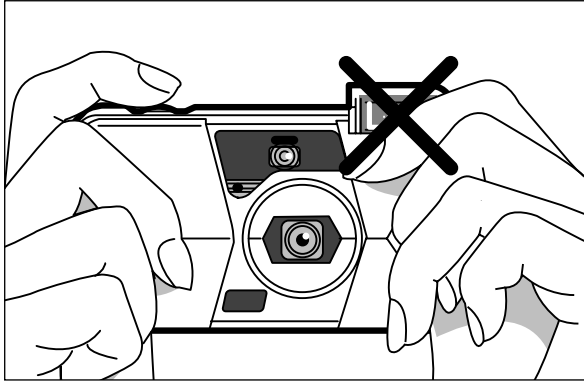

Fig. 25

Ensure that fingers or the camera strap are not obscuring the lens of flash assembly.

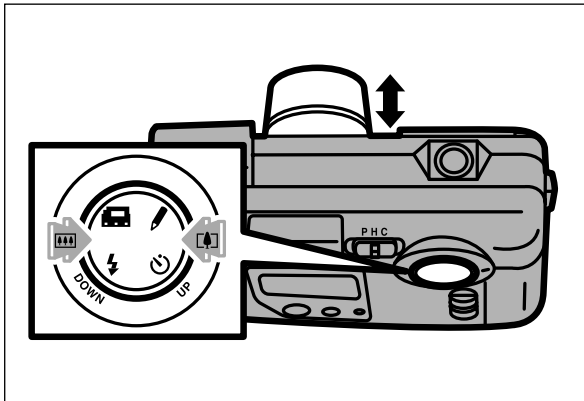



Fig. 26

Press the multi-operation button's  mark until the required level of zoom has been acquired when the subject is to be magnified. Press the  mark to obtain the wide-angle zoom.

* The minimum distance for exposure is 0.6 m.

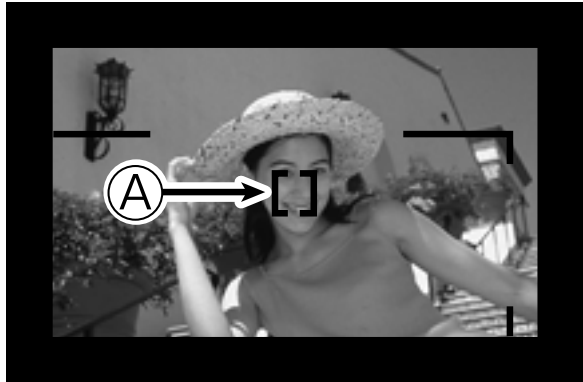

Fig. 27

Aim at the subject so that it fills the whole AF frame.
(A : AF (Autofocus) frame)

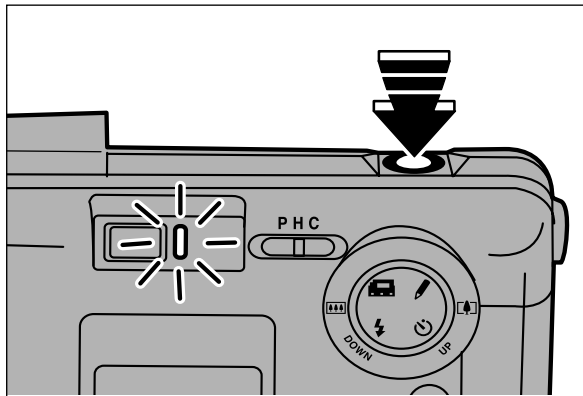

Fig. 28

When the shutter release button is pressed halfway and the AF lamp (green) turns on, focusing is complete.

- * While the shutter release button is pressed halfway, the film speed and type of film is indicated in the LCD.
- * When you are too close to the subject, the AF lamp (green) will start blinking.
- * Note that when you are closer than about 20 cm, the AF lamp turns on but focusing will not be sharp.

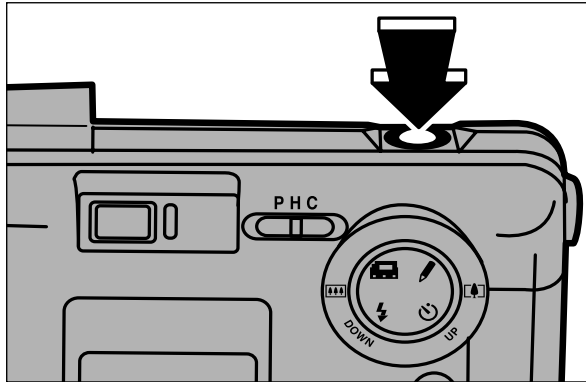

Fig. 29

When the shutter trips, the flash fires and the film advances to the next frame.

- * For bright remote scenes, the flash does not fire.
- * The AF lamp will go off once and reappear immediately after the shutter is released.
- * During the charging time of the flash (when the alarm sign is blinking “ ⚡ ”) the shutter cannot be released.

- In dark places, photos should be taken within the following flash lamp ranges.

Effective flash lamp range

Film speed	Wide angle (23mm)	Telephoto (50mm)
ISO 100	0.6 - 3.5	0.6 - 1.8
ISO 200	0.6 - 5.0	0.6 - 2.6
ISO 400	0.6 - 7.0	0.6 - 3.7

(Using color negative film; units; m)

- In the following cases, the camera may not be able to focus on the subject. Such subjects must be shot using the “AF-lock” or “Landscape Mode”. (Refer to Fig.30 – 33 and 50.)
- ① A bright light source such as the sun is near the subject or there is reflected light (from the windscreen of a vehicle, waves, etc.) near the subject.
- ② A mirror or light-reflecting surfaces such as metals are near the center of the picture.
- ③ When shooting black light-absorbing subjects such as hair.
- ④ There are gaseous substances such as flame or smoke.
- ⑤ Taking pictures through glass.

USING THE AUTO-FOCUS LOCK



Fig. 30

In the composition shown above, the AF frame is off the subject (in this case, the people). In this state the lens will not focus on the subject.

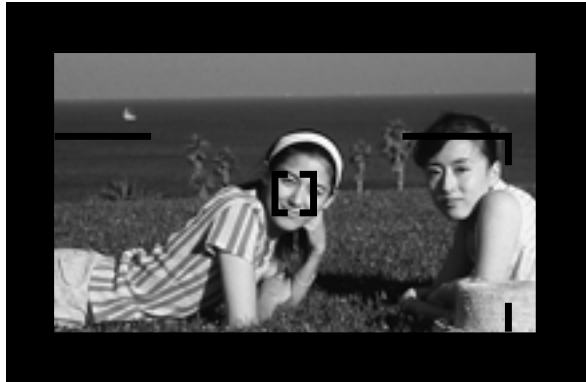

Fig. 31

Move the camera slightly so that the subject is inside the AF frame.

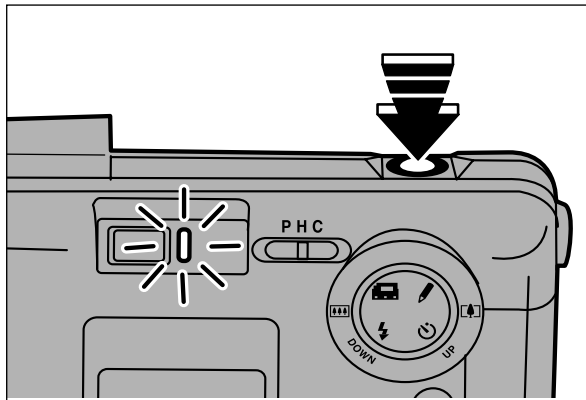

Fig. 32

Press the shutter release button halfway down and confirm that the AF lamp lights without moving the camera. (Focus is locked on your subject in this condition.)



Fig. 33

While holding the shutter release button halfway down to keep the Auto-Focus lock on, move the camera back to the original position to recompose your picture, then press the shutter release button all the way down.

* The Auto-Focus lock operation can be repeated any number of times before the shutter trips.

UNLOADING THE FILM CARTRIDGE



Fig. 34

When the last frame has been exposed, the film is rewound. The exposure counter shows the number of frames remaining after subtracting the exposed frames from number of frames specified on the film cartridge. When rewinding of the film is finished, an “E” sign will appear in the exposure counter.

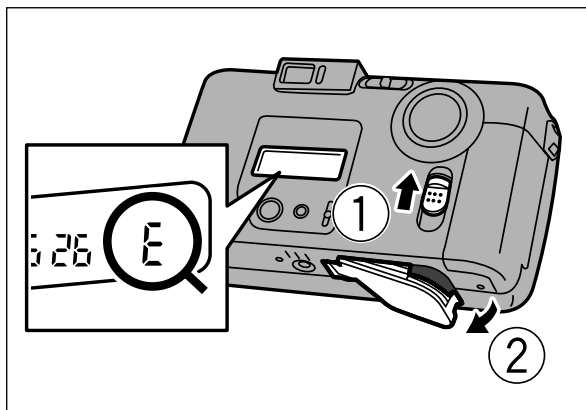

Fig. 35

When the exposure counter shows “ E ” and the motor stops, move the film cartridge compartment cover release knob as indicated in ①, in the direction indicated in ②, and open the film cartridge compartment cover.

* Always stop the motor and check that “ E ” is displayed before moving the film cartridge compartment cover release knob. If you try to open the film cartridge compartment cover before “ E ” is displayed, the camera may be damaged, or the film may be exposed.

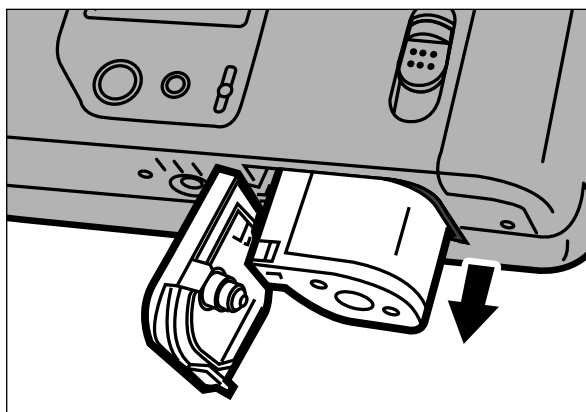



Fig. 36

Take out the film cartridge after opening the cartridge compartment cover.

*  is displayed on the cartridge.
 * Do not apply unnecessary force to the cartridge compartment cover.

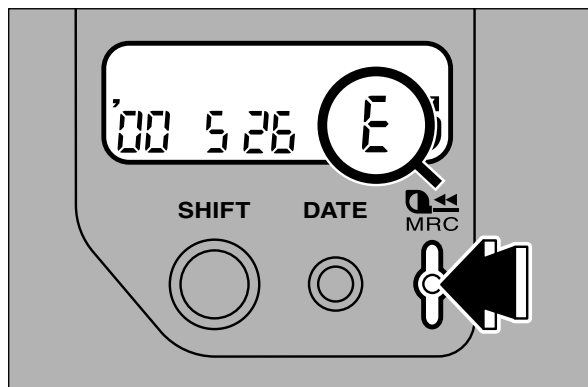

Fig. 37

Press the mid-roll change button to rewind the film when the cartridge is to be ejected in the middle of the roll. Do not remove the cartridge until “ E ” is displayed in the exposure counter and the rewind motor has ceased to operate.

* When rewinding a roll of film which is only partially exposed. Refer to CARTRIDGE MID-ROLL CHANGE FUNCTION.

CARTRIDGE MID-ROLL CHANGE FUNCTION



Fig. 38

With the Advanced Photo System

The cartridge can be replaced even in mid-roll. This convenient feature makes it possible for family members to alternate using one camera, to keep hobby pictures separate from photographs for work, and to interchange cartridges with different film speeds.

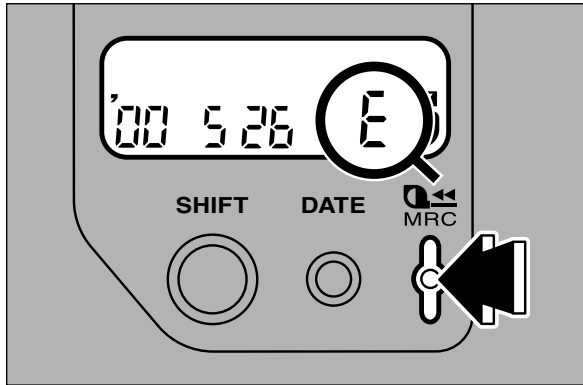

Fig. 39

Press in the mid-roll change button. The film counter will display as it subtracts from the number of exposed frames. When rewinding is completed, “ E ” will be displayed by the film counter.

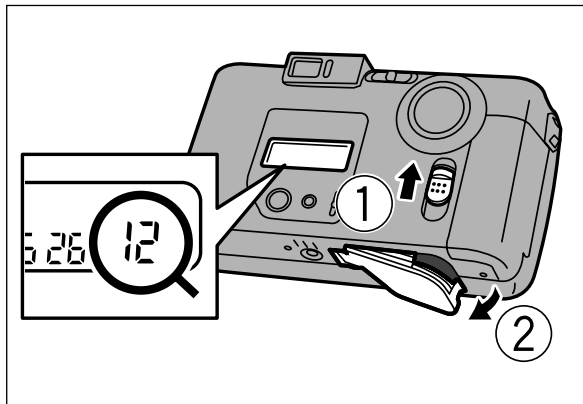

Fig. 40

When “ E ” appears in the film counter and the motor has stopped, raise the cartridge compartment cover release knob as shown in illustration ①, move it in the direction shown in illustration ② and open the cartridge compartment cover. The number of unexposed frames will be displayed by the film counter at this time.

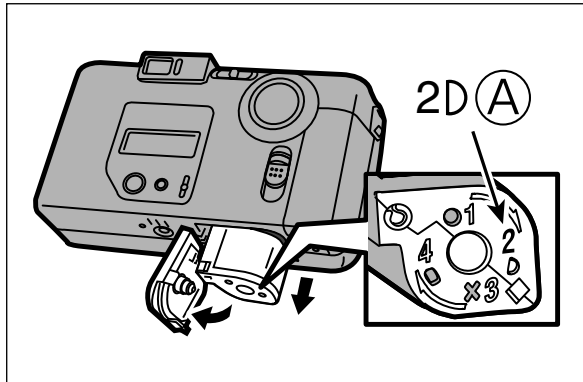

Fig. 41

Remove the cartridge and sign sure the sign D appears white.

(A) : Film cartridge with unexposed frames)

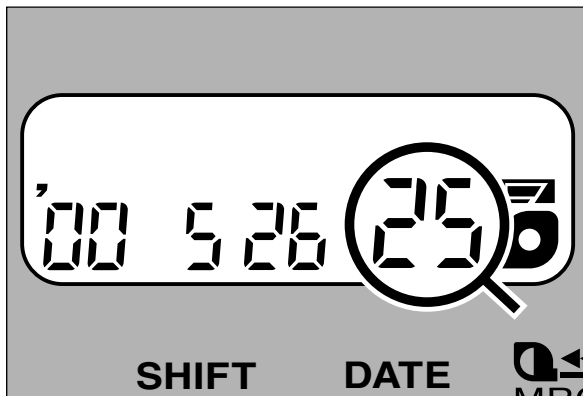

Fig. 42

When a new cartridge is loaded (A), the film will be advanced to the first frame and the number of available exposures will be displayed.

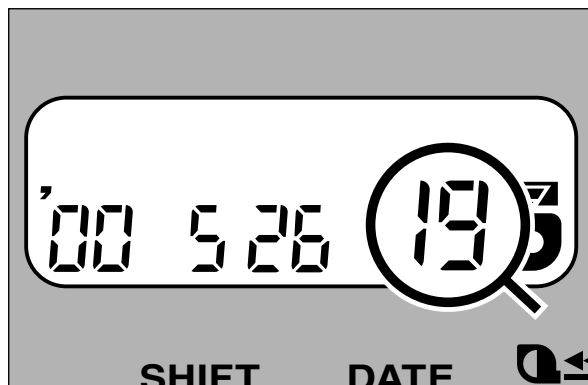

Fig. 43

When a cartridge that was removed in mid-roll D is reloaded, the film will automatically be advanced to the first unexposed frame. After that, operation is as before.

- * Even if you forget how many frames were exposed on a cartridge that was removed in mid-roll, just reload the cartridge. The camera will automatically set the remaining number of unexposed frames and display that number on the LCD.

● Cautions Concerning the Mid-roll Change Function

- * When a cartridge that has been removed in mid-roll (D is displayed) is reloaded into the camera, if “ E ” blinks in the film counter, reload the cartridge once more, avoiding the following locations.
 - Anywhere near a drier, fan, vacuum cleaner, etc., which has a rotating motor.
 - Near an active TV or personal computer display.
- * If a cartridge is removed in mid-roll D and then loaded into a camera which does not have the MRC function, the cartridge will be set to exposed X and can no longer be used.
- * A cartridge removed in mid-roll X from a camera which does not have the MRC function cannot be used even if loaded into this camera.

- * If a cartridge is removed in mid-roll D and sent to the processor, all frames on the entire roll will be developed. Expose all frames on the roll before sending the cartridge to the processor for development.
- * Mid-Roll change of cartridge is guaranteed only among our FOTONEX/ENDEAVOR series and nexia series of cameras with MRC functions. If a cartridge exposed with another make of camera with an MRC function is used, operation may not be normal.

3. ADVANCED TECHNIQUES

SELECTING THE EXPOSURE MODE

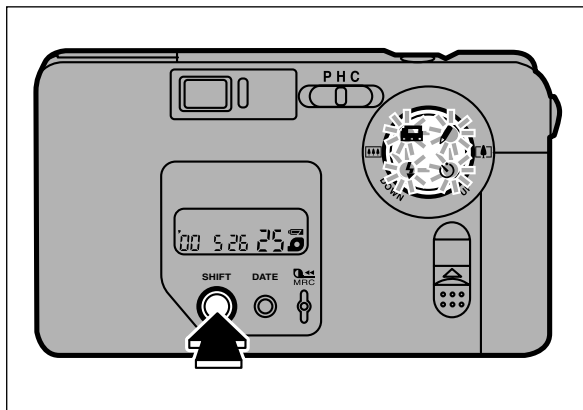





Fig. 44

Switch on the power and press the SHIFT button to illuminate the four guide lamps ( /  /  / ).

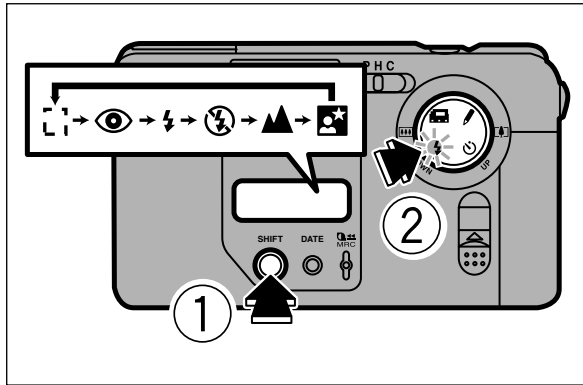

Fig. 45

Hold down the SHIF button ① and press the ⚡ mark on the multi-operation button ② to illuminate only the ⚡ guide lamp. Continue pressing the ⚡ mark to enable sequential selection of the exposure mode.

The mode displayed in the LCD will be selected when the SHIF button is released, and the guide lamp will be extinguished.



Fig. 46

 No display : **Multi program flash mode**

Used during normal exposures

The amount of flash released will be automatically adjusted in accordance with the brightness, distance and magnification of the subject.

- * For bright remote scenes, the flash does not fire.
- * Refer to pages 31 to 32 for further details on the Multi Program flash.



Fig. 47

: Red-eye reduction flash mode

Reduces red-eye

The flash lamp will fire briefly 5 times (pre-flash), then fire the 6 time for taking your picture.

* The AF lamp sign in the viewfinder eyepiece stays on from pre-flash to exposure. Do not move the camera while the AF lamp is on.

● **About red-eye**

When a person is photographed with flash in dim light, the eyes will sometimes turn out red. This is because the light from the flash lamp is reflected back into the lens from the back (retina) of the person's eyes.

In addition to using the red-eye reduction mode, observance of the following is effective in reducing red-eye.

- Have the person being photographed look directly at the camera lens.
- Take pictures by approaching as close as possible to the subject.



Fig. 48

⚡ : Fill-in flash mode

Used when taking against-the-light pictures of a person standing by a window or under the shade of a tree.

Takes flash exposures even in bright locations.



Fig. 49

ⓧ : Flash off mode

Use when taking pictures using interior light or for taking distant subjects which the flash lamp light cannot reach, such as in a theater or stadium.

The flash lamp will not flash.

* When taking pictures in a dark place, we recommend the use of a tripod to prevent the camera from shaking.



Fig. 50

▲ : Landscape mode

This is used for taking clear landscape pictures or photographing remote (night) scenes through glass.

Set the focus in the distance. The flash will not operate.

- * This feature will be canceled after every exposure.
- * When taking pictures in a dark place, we recommend the use of a tripod to prevent the camera from shaking.



Fig. 51

👤★ : Night portrait (slow sync) mode

This is used for taking photographs of people at night.

The camera will enter the slow-shutter red-eye reduction mode (flash emitted after 5 pre-flashes) to enable the clear exposure of both night scenes and human subjects.

- * This feature will be canceled after every exposure.
 - * As a slow shutter speed is used with the night portrait mode, ensure that a tripod is used to prevent camera-shake. It is also important that the subject remains motionless during the exposure.
 - * The fill-in flash mode, the flash off flash mode, and landscape mode and the night portrait (slow shutter) mode will be canceled when the power is switched off.
- To enable the continual use of the landscape mode and night portrait mode, press the multi-operation button's  mark for 2 or more consecutive seconds when selecting the mode until the mark changes from being illuminated to blinking. The mode will then remain in place after exposure to enable continual use. This feature will be canceled automatically when the power is switched off.

THE “USER TITLE” SELECTION

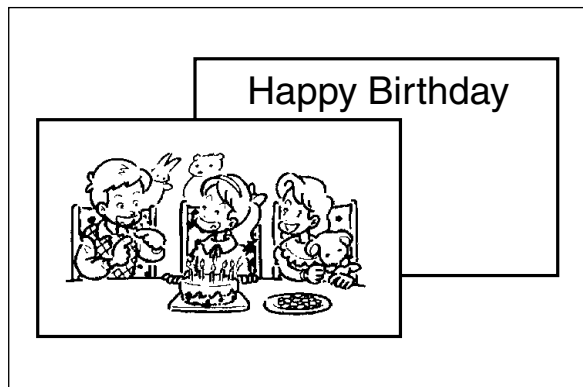

Fig. 52

With the Advanced Photo System

Messages or titles can be printed on the back of prints when taking pictures.

- * User title selection can be changed when reprinting. (Some photo finisher's may not support this feature.)

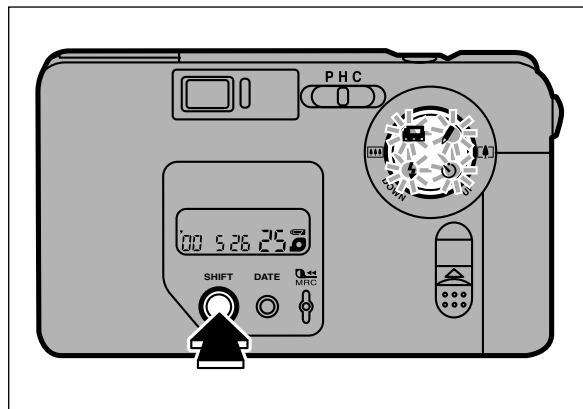

Fig. 53

Press the SHIFT button to illuminate the 4 guide lamps (⚡ / ✎ / 📷 / 😊).

- * 3 guide lamps (⚡ / ✎ / 😊) will be illuminated during title selection.
- * When you want to select both user title selection and print quantity, set either of the functions after taking the photograph. (Refer to Fig.65 – 67.)

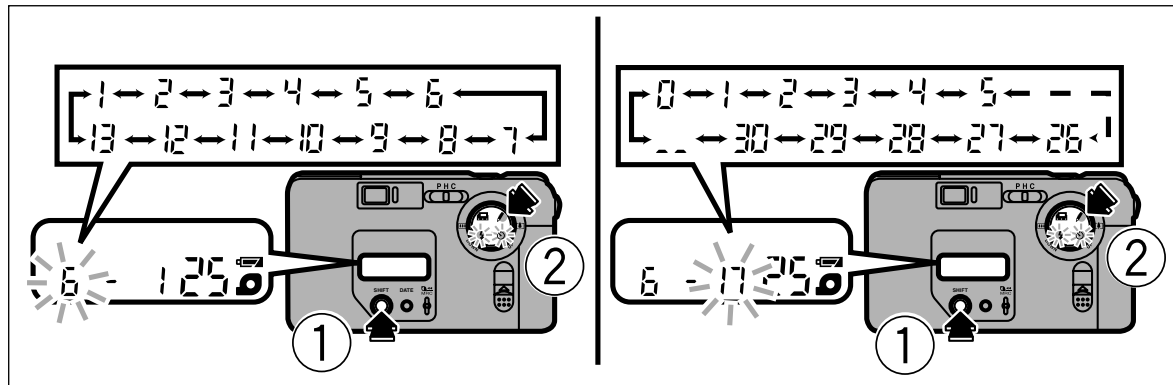





Fig. 54

Language selection:

Hold down the SHIFT button ① and press the  mark on the multi-operation button ② for 2 or more consecutive seconds to illuminate the  guide lamp and set the UP and DOWN guide lamps blinking. The language number will blink on the LCD.

Title selection:

Hold down the SHIFT button ① and press the  mark on the multi-operation button ② to illuminate the  guide lamp and set the UP and DOWN guide lamps blinking. The title number will blink on the LCD.

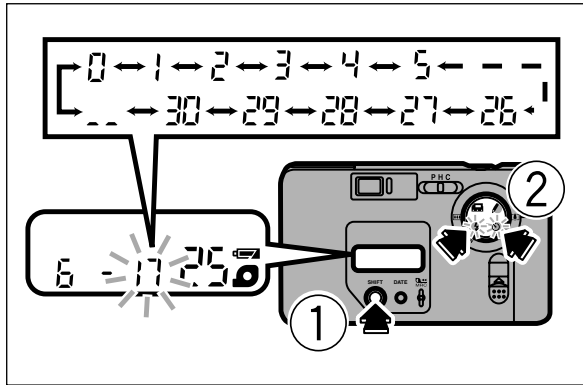

Fig. 55

Continue to press the SHIFT button ① and select the number with the UP and DOWN ② buttons. The number displayed in the LCD will be selected when the SHIFT button is released. (Refer to page 54 for details on the numbers.)

- * Language and titles cannot be amended simultaneously. Make all necessary amendments independently.
- * The title number is the number “30” followed by “_ _”. No title will be printed if you set the title number to “_ _”.

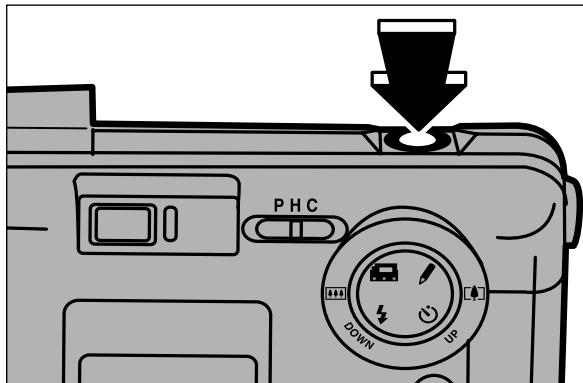

Fig. 56

Press the shutter release button to take a picture. The film is advanced and the selected title is recorded.

- * To cancel the select title mode, reset the power switch.
- * Although the date is not displayed, it is imprinted on the photograph.
- * The user select title is cancelled after every exposure (shutter release). When the self-timer is used, it is cancelled after the set number of exposures are finished.

CHANGING THE “USER TITLE” SELECTION

The title of the last exposed frame can be changed any number of times before the next frame is exposed. This is convenient when one has forgotten to set the title before exposure, or when changing the title.

Fig. 57

* Overwriting is not possible if the cartridge is removed midway or the batteries are removed after exposure.

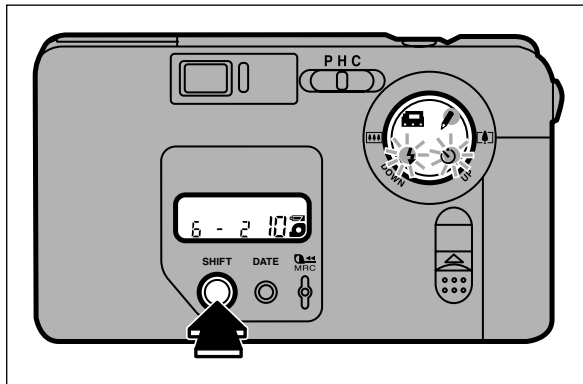

Select the required title from the sequence available in [THE “USERTITLE” SELECTION] and then continue to press the SHIFT button. (Refer to Fig.52 – 56.)

Fig. 58

Hold down the SHIFT button ① (with the title number blinking on the LCD) and press the  mark on the multi-operation button ② for 1 or more consecutive seconds.

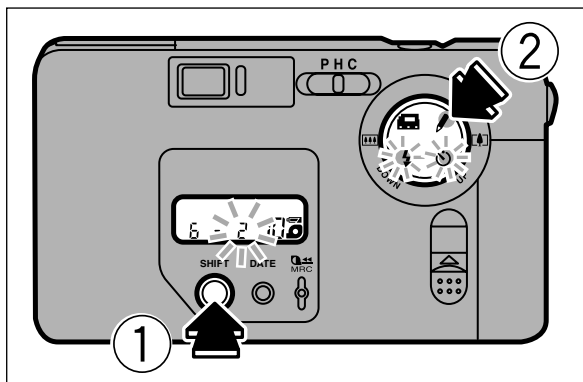

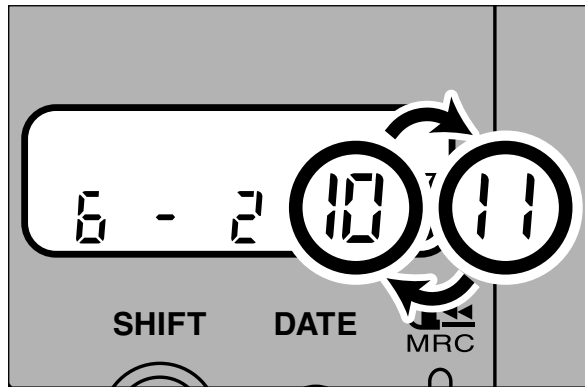

Fig. 59

The exposure film is rewound once (the exposure counter also counts back 1 frame) then returned to the last position. The exposure counter also returns to its original value, and the title is changed.

PRINT QUANTITY

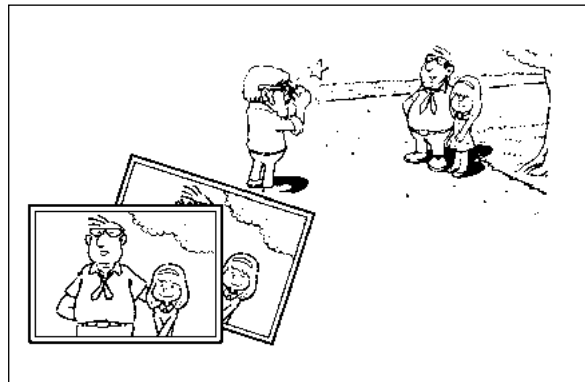

Fig. 60

With the Advanced Photo System

The desired print quantity for each frame can be set when taking pictures. The necessary print quantity is simultaneously printed at the first printing so troublesome reprinting is not necessary. 0 to 10 prints can be specified for every frame.

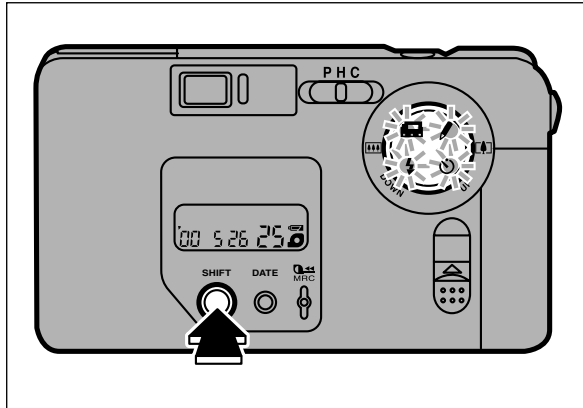

Fig. 61

Press the SHIFT button to illuminate the 4 guide lamps (⚡ / ✎ / 📷 / ⌚).

- * 3 guide lamps (⚡ / ✎ / ⌚) will be illuminated during print quantity specification.
- * When you want to select both user title selection and print quantity, set either of the functions after taking the photograph. (Refer to Fig.57 – 59.)

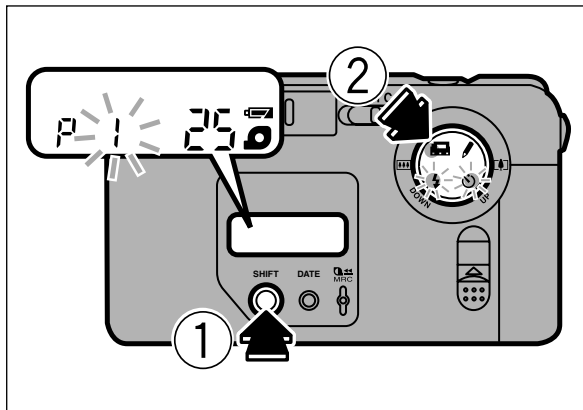

Fig. 62

Hold down the SHIFT button ① and press the 📷 mark on the multi-operation button ② to illuminate the 📷 guide lamp and set the UP and DOWN guide lamps blinking. The print quantity will blink on the LCD.

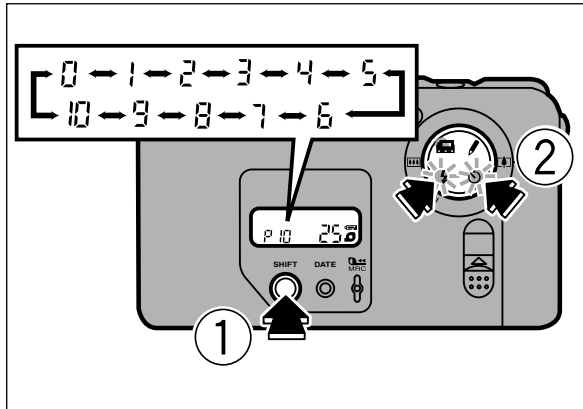

Fig. 63

Continue to press the SHIFT button ① and select the quantity with the UP and DOWN ② buttons. The quantity displayed in the LCD will be selected when the SHIFT button is released.

- * If you want to cancel the specified print quantity, reset the power switch.
- * Although the date is not displayed, it is imprinted on the photograph.

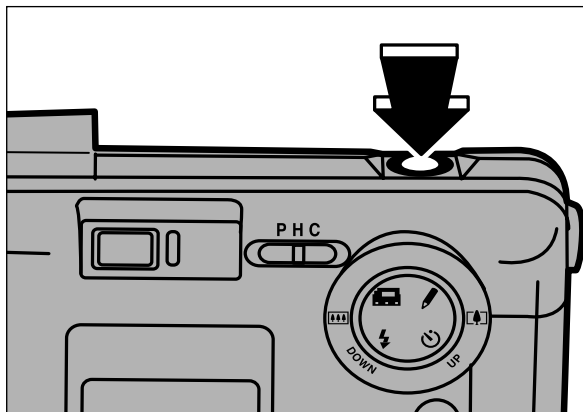

Fig. 64

Press the shutter release button to take a picture. The film is advanced and print quantity is recorded.

- * Print quantity is cleared automatically after each exposure, or when a new film cartridge is loaded. The self-timer exposure feature will be canceled after the preset number of exposures have been taken.

CHANGING THE PRINT QUANTITY

This is convenient when one has forgotten to set the print quantity before exposure, or when one does not want a print because of an exposure failure.

* Overwriting is not possible if the cartridge is removed midway or the batteries are removed after exposure.

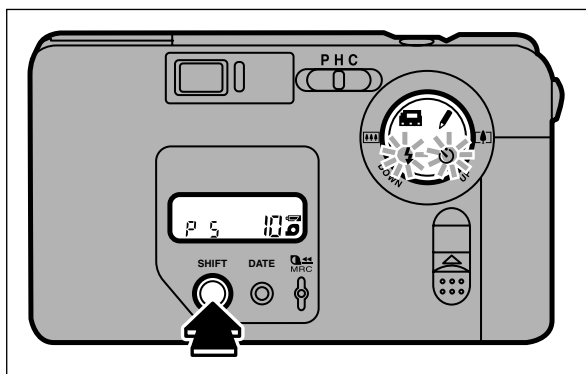

Fig. 65

Select the required print quantity from the sequence available in [PRINT QUANTITY] and then continue to press the SHIFT button. (Refer to Fig.60 – 64.)

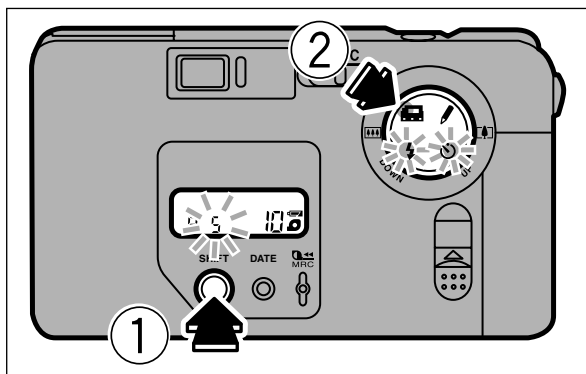

Fig. 66

Hold down the SHIFT button ① (with the print quantity blinking on the LCD) and press the camera icon mark on the multi-operation button ② for 1 or more consecutive seconds.

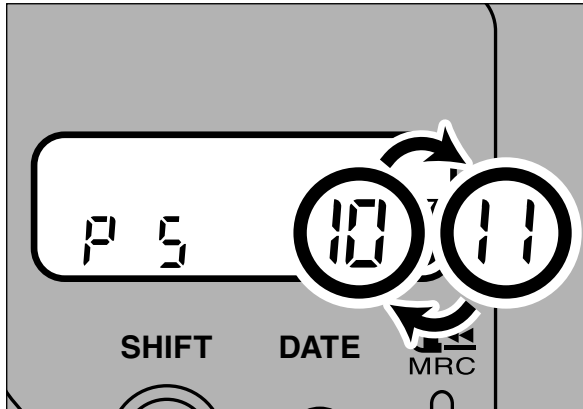

Fig. 67

The film is first rewound (the counter is reset to frame 1), then advanced to its original position (the counter is also advanced), and the print quantity is changed.

USING THE SELF-TIMER

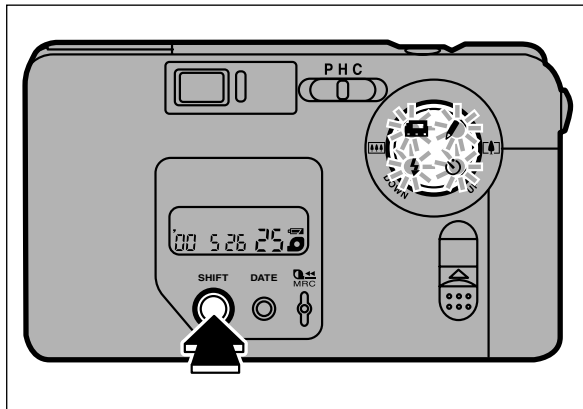

Fig. 68

Press the SHIFT button to illuminate the 4 guide lamps (⚡ / ✎ / 🔋 / ⌚).

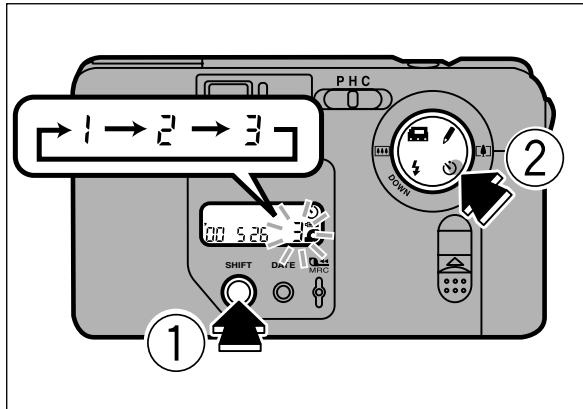





Fig. 69

Hold down the SHIFT button ① and press the  mark on the multi-operation button ② to illuminate only the  guide lamp. Continue to press the  mark to select the number of required self-timer exposures (maximum of 3.) The self-timer exposure count displayed in the LCD will be selected when the SHIFT button is released, and the guide lamp will be extinguished.

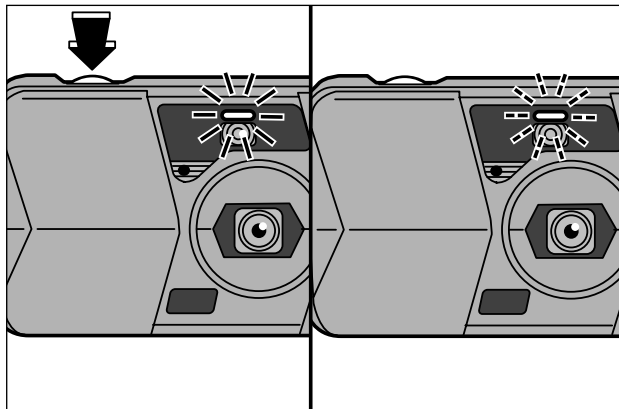



Fig. 70

When the shutter release is depressed, the camera focuses on the subject in the AF frame and the self-timer starts. The self-timer lamp (or multi-operation button's guide lamp) will begin to blink approximately 7 seconds after being illuminated, and the shutter will be released approximately 3 seconds after that. Subsequent self-timer exposures will be taken at intervals of between 3 to 6 seconds when 2 or 3 consecutive self-timer exposures have been set.

* Do not press the shutter release button while standing in front of the camera. This may cause a focusing error or underexposure.

- * To cancel an activated self-timer exposure, press the  mark on the multi-operation button and extinguish the guide lamp.
- * The self-timer mode will be automatically canceled after the exposure has been taken and when the power is switched off.

MULTI PROGRAM FLASH

A word on multi program flash

A new function which allows the camera photographing conditions and automatically adjusting the quantity of light emitted by the flash by analyzing the brightness of the subject, the distance, and the focal length of the lens.

The flash always fires automatically unless the subject is bright or too far. This programmed flash allows anyone to take clean pictures simply.

Some practical examples are introduced to explain the effects.



Fig. 71

- **Close-up photography in a room or night scene**
When close-up pictures are taken in a dim place with an ordinary flash, it fires in 100%. As a result, the subject is blurred in white. The multi program flash reduces the light quantity down to 12.5%, preventing pictures to be blurred in white.



Fig. 72

- **Portrait photography at high brightness**
When a person is photographed in bright daylight, his (her) face is likely to be spotted with the shades of hair and nose. Even in such a case, the multi program flash automatically fires to reduce the shades. It seems unnecessary to use the flash in a bright place. However, you will understand the effect by comparing a picture taken with the flash used and a picture taken without using the flash.



Fig. 73

● **Photography against the sun**

When photographing a person who is backlit or standing by a window, the subject appears as a shadow. As a result, the features will be too dark to distinguish. In this case also, the multi-program flash automatically provides the correct amount of light so that you can take beautiful pictures.





CAMERA CARE AND CAUTIONS

- 1 Your camera is a precision instrument which requires careful handling. Do not expose it to shock, liquid, or drop it on the floor.
 - ① If you use the camera at the seaside or in light rain, be careful not to get it wet. Also be careful not to put the camera in places where it will be easily exposed to sand.
 - ② Dropping the camera on the floor or striking it against hard objects sometimes causes trouble even though it may be in the camera case. Also do not put the camera in places where it is exposed to vibrations (such as the trunk of a car).
- 2 If you are not using your camera for a long time, keep it where it will be safe from heat, moisture, dust, and harmful gases (such as naphthalene which is used in drawers).

- 3 Since this camera is computer-controlled, it almost never operates erroneously. If erroneous operation should occur, remove and then reload the battery.
- 4 This advanced photo system magnetically records the information on the film. Therefore, do not expose film cartridges or a film cartridge loaded camera to strong magnetic fields.
- 5 Do not put the camera in a closed car for a long time.
- 6 It is recommended that undeveloped film and cameras containing film are carried as hand luggage when using aircraft. If included in checked-in baggage, X-ray inspections may cause overprinting or other effects.
- 7 Remove soil and dust from the lens, the AF window and the finder with an air blower and by wiping lightly with a piece of soft cloth. If that is not enough, wipe off gently with Lens Cleaning Paper, moistened slightly with Lens Cleaning Liquid. Do not use organic solvents such as alcohol and benzene.
- 8 The operating temperature range of the camera is from -10°C to $+40^{\circ}\text{C}$.
- 9 Since the performance of the battery will drop in cold district, warm the battery by placing it inside your garments, etc. before use. The performance of a battery whose performance has temporarily dropped can be recovered by returning the battery to normal temperature.

ERRORS, POSSIBLE CAUSES, AND REMEDIES

During operation

Error	Possible Causes	Remedies	Page
The LCD shows “E” and “  ” blinking though a film cartridge has been loaded and the film cartridge compartment cover has been closed.	<ul style="list-style-type: none"> ● Open the film cartridge compartment cover and check the film cartridge status mark. Are you using a film cartridge with a white  mark or D. 	<ul style="list-style-type: none"> ● Use a film cartridge with a white  mark or D. 	11
A cartridge has been inserted, but the counter is not displayed on the LCD. The film will not wind on.	<ul style="list-style-type: none"> ● Check to ascertain that the batteries have been inserted after the cartridge. 	<ul style="list-style-type: none"> ● The shot will not be taken if the shutter was operated in this condition. Remove the cartridge without rewinding, and then reload it again. 	11
The shutter release won't trip.	<ol style="list-style-type: none"> ① “” symbol is blinking ② Power switch is not on. ③ “E” is lit on the exposure counter. 	<ol style="list-style-type: none"> ① Replace the battery with a new one. ② Turn on the power by opening the slide cover and set the camera to the ready-to-shoot state. ③ Remove the film cartridge and load an unused film cartridge or a film cartridge with unexposed frames remaining. 	6 7 12
The film cartridge compartment cover cannot be opened.	<ul style="list-style-type: none"> ● Are you attempting to open the film cartridge cover in the middle of a roll? 	<ul style="list-style-type: none"> ● Rewind the film with the mid-roll change button. When “E” appears in the exposure counter, unload the film cartridge. 	23

Printed pictures

Error	Possible Causes	Remedies	Page
Picture is not sharp.	<ul style="list-style-type: none"> ① Was your finger on the AF windows when shooting? ② Did you aim the subject properly? ③ Is the lens dirty? ④ Is the camera shaking? ⑤ You selected ▲ mode when shooting at a close distance. 	<ul style="list-style-type: none"> ① When shooting a picture, hold your camera correctly so that your finger is not on the AF windows. ② Compose the picture in the AF frame and shoot, or shoot using AF Lock. ③ Clean the lens. ④ Hold the camera firmly and press the shutter release button gently. Use a tripod for slow shutter speeds. ⑤ Select a mode other than ▲ mode. 	<ul style="list-style-type: none"> 17 21 47 17 33
Picture is dark.	<ul style="list-style-type: none"> ① Subject was too far from the camera for flash photography in a dark place. ② Was your finger over the flash? 	<ul style="list-style-type: none"> ① Shoot within specified coverage distance of electronic flash. ② Do not cover the flash with your finger. 	<ul style="list-style-type: none"> 20 18

Error	Possible Causes	Remedies	Page
Printed date/time is incorrect.	● You didn't set correct date and time after replacing battery.	● Set date and time after replacing battery.	8
The date is not printed on the front.	<ul style="list-style-type: none"> ① Wasn't "- - - - -" selected before taking pictures ? ② Some print service shops do not support frontprinting. 	<ul style="list-style-type: none"> ① Select a date mode other than "- - - - -" before taking pictures. ② Please consult your nearest photo finisher. 	10



SPECIFICATIONS

- **Film**

IX240 Cartridge film

- **Picture Size**

16.7 mm x 30.2 mm

- **Print Format**

P/H/C switchable

- **Lens**

Super EBC Fujinon zoom lens, 5 components, 5 elements, f=23 – 50 mm 1:5.0 – 1:8.8

- **Viewfinder**

Super EBC zoom finder, 0.36 – 0.69X magnification, P, H and C formats switchable with AF frame, parallax correction mark, AF Lamp

- **Focusing**

Active type auto focus: 0.6 m – ∞, with AF lock, landscape mode (long distance lens position setting, flash off setting), AF lamp (on: range OK, blinking: over range alarm)

- **Shutter Release**

Programmed electronic shutter release, 1 – 1/400 sec. shutter release speeds

- **Exposure Control**

Automatic

Interlocking range (ISO 200), EV (wide angle): 10 (*7) – 17, EV (telephoto): 12 (*7) – 18 (* = values for the flash off mode)

- **Film Speed Setting**

Automatic (data disk system) for ISO 25 – 3200

- **Film Loading**

One touch drop-in loading system, film safety lock system, with optical double exposure prevention

- **Film Advance**

Automatic (motorized) wind and rewind system, provision for mid-roll rewinding, cartridge mid-roll change function

- **Flash**

Multi program flash, 1 – 5 seconds recycle time, multi program flash mode, red-eye reduction flash mode, fill-in flash mode, flash off mode, night portrait (slow sync) mode

- **Self-Timer**

Electronically controlled, up to 3 consecutive exposures approximately 10 second delay, can be stopped mid-run, self-timer on lamp

- **Liquid Crystal Display**

Exposure counter, exposure mode index, cartridge loaded/unloaded sign, self-timer mode sign, battery capacity sign, flash charging sign, date sign, print quantity sign, user title selection sign, type of film cartridge sign, film speed sign

- **Data Recording**

Magnetic recording system, recordable on each frame, print quantity, user select title, print format, BASIC PQI (print quality improvement) information

- **Power Supply**

One CR123A/DL123A lithium battery or comparable battery

- **Others**

Tripod socket

- **Dimensions & Weight**

109 x 62 x 39 mm, 175 g (without battery)

* Specifications are subject to change without notice.



LIST OF AVAILABLE TITLES

GBR British English

12-0	Christmas	12-15	Thank You
12-1	Birthday	12-16	Season's Greetings
12-2	Vacation	12-17	Happy Birthday
12-3	Honeymoon	12-18	Congratulations
12-4	Wedding	12-19	Merry Christmas
12-5	Hanukkah	12-20	Festival
12-6	Graduation	12-21	First day of School
12-7	Family	12-22	Tour
12-8	Party	12-23	New Year's
12-9	Holiday	12-24	Easter
12-10	Anniversary of Marriage	12-25	Happy New Year
12-11	Friends	12-26	Reunion
12-12	School Event	12-27	Father's Day
12-13	Trip	12-28	Mother's Day
12-14	I Love You	12-29	Memories
		12-30	Baptism

USA American English

13-0	Christmas	13-16	Season's Greetings
13-1	Birthday	13-17	Happy Birthday
13-2	Vacation	13-18	Congratulations
13-3	Honeymoon	13-19	Merry Christmas
13-4	Wedding	13-20	Festival
13-5	Hanukkah	13-21	First day of School
13-6	Graduation	13-22	Tour
13-7	Family	13-23	New Year's
13-8	Party	13-24	Easter
13-9	Holiday	13-25	Happy New Year
13-10	Anniversary	13-26	Reunion
13-11	Friends	13-27	Father's Day
13-12	School Event	13-28	Mother's Day
13-13	Trip	13-29	Memories
13-14	I Love You	13-30	Baptism
13-15	Thank You		



26-30, Nishiazabu 2-chome, Minato-ku, Tokyo 106-8620, Japan.

<FUJIFILM ABROAD>

In North America

FUJI PHOTO FILM U.S.A., INC.

555 Taxter Road, Elmsford, N.Y. 10523, U.S.A.

FUJI PHOTO FILM CANADA INC.

275 Britannia Road East, Mississauga, Ontario, L4Z 2E7, Canada

FUJI PHOTO FILM HAWAII, INC.

1650 Kalakaua Avenue, Honolulu, Hawaii 96826, U.S.A.

In Europe

FUJI PHOTO FILM (EUROPE) G.m.b.H.

Heesenstrasse 31, 40549 Dusseldorf, Germany

FUJI PHOTO FILM (U.K.) LTD.

Fuji Film House, 125 Finchley Road, Swiss Cottage, London NW3 6JH, England

FUJI FILM ESPAÑA, S.A.

Aragon, 180, 08011-Barcelona, Spain

In South America

FUJI PHOTO FILM DO BRAZIL LTDA.

Avenida Vereador Jose Diniz No. 3.400, Campo Belo- CEP 04.604

Cx. Postal 9.959., Sao Paulo-SP, Brazil

In Asia

FUJI PHOTO FILM CO., LTD., HONG KONG OFFICE

Room 916, Sun Plaza, 28 Canton Road, Tsim Sha Tsui, Kowloon, Hong Kong

FUJI PHOTO FILM (SINGAPORE) PTE. LTD.

10 New Industrial Road, Singapore 536201

FUJI PHOTO FILM (THAILAND) LTD.

S.P. Building, 8th Floor, 388 Phaholyothin Road, Bangkok 10400, Thailand

FUJI PHOTO FILM (MALAYSIA) SDN. BHD.

Letter Box 3, 3rd Floor Office Block 1, Crystal Plaza Lot 4, Jalan 51A/223, 46100 Petaling Jaya Selangor Darul Ehsan Malaysia

FUJI PHOTO FILM CO., LTD., TAIPEI OFFICE

Rm. 601, Hung Chong Bldg., No.38, Sec. 6, Min Chuan E. Road, Taipei 11412, Taiwan, Republic of China

FUJI PHOTO FILM CO., LTD., SEOUL OFFICE

Samduck Bldg. 6F., 144-1, Samsung-Dong, Kang Nam-ku, Seoul 135-090, Korea

FUJI PHOTO FILM CO., LTD., BEIJING REPRESENTATIVE OFFICE

Beijing Fortune Bldg. No. 817, 5, Dong Sanhuan Bei-lu, Chaoyang District, Beijing, China 100004

FUJI PHOTO FILM CO., LTD., HO CHI MINH OFFICE

29-31 Ton That Thiep St., Q.I Ho Chi Minh City, Vietnam

FUJI PHOTO FILM CO., LTD., NEW DELHI OFFICE

Le Meridian Commercial Tower 8F Janpath, New Delhi 110001, India

In Oceania

FUJI PHOTO FILM CO., LTD., SYDNEY REPRESENTATIVE OFFICE

c/o Hanimex Pty. Limited, Old Pittwater Road, Brookvale, N.S.W. 2100, Australia

In Middle East

FUJI PHOTO FILM CO., LTD., DUBAI OFFICE

No. 4G-17, L.O.B. No. 4, P.O. BOX 17212, Jebel Ali, Dubai, U.A.E.

Free Manuals Download Website

<http://myh66.com>

<http://usermanuals.us>

<http://www.somanuals.com>

<http://www.4manuals.cc>

<http://www.manual-lib.com>

<http://www.404manual.com>

<http://www.luxmanual.com>

<http://aubethermostatmanual.com>

Golf course search by state

<http://golfingnear.com>

Email search by domain

<http://emailbydomain.com>

Auto manuals search

<http://auto.somanuals.com>

TV manuals search

<http://tv.somanuals.com>