

Bump Case User's Guide

FPCCC47

I N S T R U C T I O N S

These instructions provide details on using the FPCCC47 Bump Case. This case is designed for use with your Tablet PC. The bump case provides added protection when transporting, using, or storing the Tablet PC.

We strongly recommend that you read these instructions prior to using the bump case with your computer.

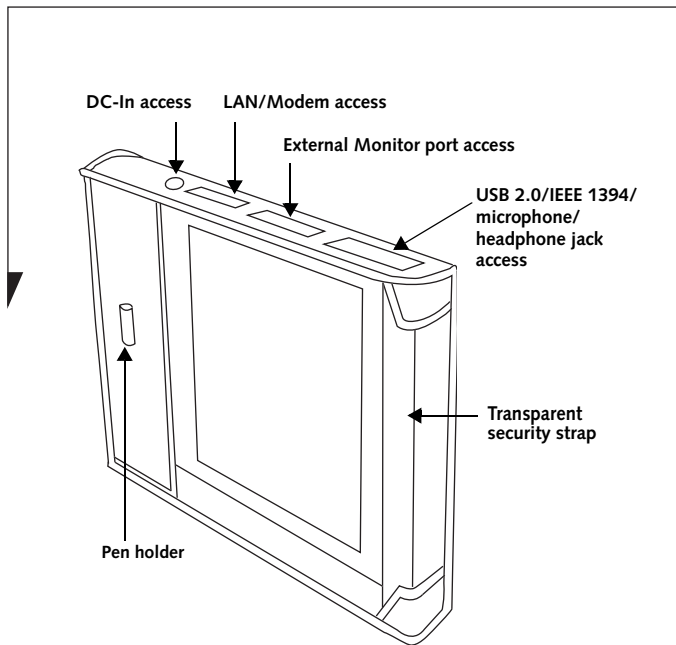

Figure 1. Bump case - Front

Installing the Tablet PC



Prior to installing the Tablet PC into the bump case, remove the pen. Once the system is installed, you will not be able to remove the pen. Store the pen in the pen holder. (Figure 1)

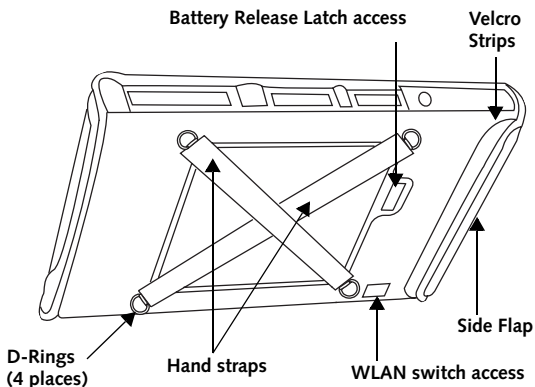

Figure 2. Bump case - Rear



This bump case is designed to accommodate a system with a standard main battery or an optional high-capacity battery installed. The high-capacity battery is wider than the main battery, so a battery strap and a foam bumper (see Figures 3 and 4) are provided to secure the system when a main battery is installed.

To install your Tablet PC into the bump case, position the case face down as shown in Figure 3. Open the side flap of the case. The flap is secured by a long strip of Velcro® that is attached to the back of the bump case. Note that the left side of the case is open for port access, but the system cannot be inserted or removed from that side.

System with high-capacity battery installed:

Remove the foam bumper that is attached to the Velcro strip on the flap prior to installing a system with a high capacity battery. Retain the bumper for when you use the system with a main battery.

Slide the system into the bump case, with the screen facing the open window. (See Figure 3). Reattach the flap to the side of the case.

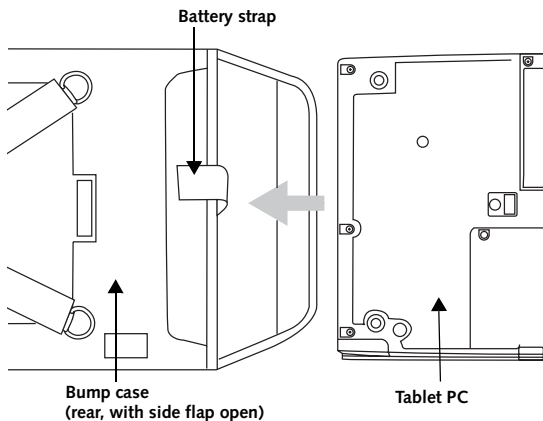

Figure 3. Inserting Tablet PC into Bump Case

System with the main battery installed:

Slide the system all the way into the bump case until it meets the opposite end of the case (see Figure 3).

Pull the battery strap down tightly and tuck it under the battery so that it is snug against the side of the battery. (See Figure 4). Insert the foam bumper into the case, with the Velcro side facing out to the right. Reattach the flap to the side of the case.

Note that either the strap or bumper can be used separately to secure the system, but for optimal security, both should be used.

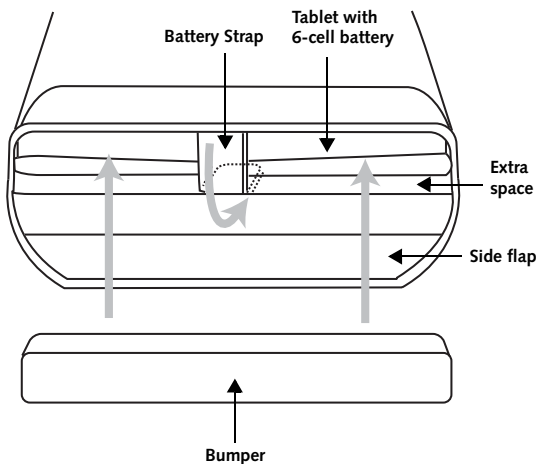

Figure 4. Securing Main Battery in Bump Case

Attaching a Shoulder Strap

The ends of the elasticized handstraps have D-rings to which you can attach the shoulder strap. To secure the shoulder strap, attach the strap clips to two of the D-rings. The bump case can be carried vertically, horizontally, or diagonally, depending on how you orient the clips.

You can also use one of the D-rings to attach a pen tether.

Caring for the bump case

The bump case is made of rugged materials, and is designed to withstand daily use. Treat the case as you would a briefcase or purse.

Occasionally, the bump case may become soiled. To clean it, use a clean cloth and warm soapy water to wash the soiled area.



1250 E. Arques Avenue (M/S 122),
Sunnyvale, California 94085

For more information, call
1-877-372-3473 or visit our Web site at:
us.fujitsu.com/computers

For technical support call: **1-800-8fujitsu (1-800-838-5487)**
or e-mail us at: **8fujitsu@us.fujitsu.com**

Fujitsu and the Fujitsu logo are registered trademarks of Fujitsu, Ltd. All other trademarks mentioned herein are the property of their respective owners.

Product description data represents Fujitsu design objectives and is provided for comparative purposes; actual results may vary based on a variety of factors. Specifications are subject to change without notice.

© 2003 Fujitsu Computer Systems Corporation. All rights reserved. FPC58-1044-01

Free Manuals Download Website

<http://myh66.com>

<http://usermanuals.us>

<http://www.somanuals.com>

<http://www.4manuals.cc>

<http://www.manual-lib.com>

<http://www.404manual.com>

<http://www.luxmanual.com>

<http://aubethermostatmanual.com>

Golf course search by state

<http://golfingnear.com>

Email search by domain

<http://emailbydomain.com>

Auto manuals search

<http://auto.somanuals.com>

TV manuals search

<http://tv.somanuals.com>