

C156-E224-01EN

MCJ3230SS

OPTICAL DISK DRIVE

PRODUCT MANUAL



FOR SAFE OPERATION

Handling of This Manual

This manual contains important information for using this product. Read thoroughly before using the product. Use this product only after thoroughly reading and understanding especially the section "Important Alert Items" in this manual. Keep this manual handy, and keep it carefully.

FUJITSU makes every effort to prevent users and bystanders from being injured or from suffering damage to their property. Use the product according to this manual.

This product is designed and manufactured for use in standard applications such as office work, personal devices and household appliances. This product is not intended for special uses (atomic controls, aeronautic or space systems, mass transport vehicle operating controls, medical devices for life support, or weapons firing controls) where particularly high reliability requirements exist, where the pertinent levels of safety are not guaranteed, or where a failure or operational error could threaten a life or cause a physical injury (hereafter referred to as "mission-critical" use). Customers considering the use of these products for mission-critical applications must have safety-assurance measures in place beforehand. Moreover, they are requested to consult our sales representative before embarking on such specialized use.

First Edition November 2001

The contents of this manual may be revised without prior notice.

The contents of this manual shall not be disclosed in any way or reproduced in any media without the express written permission of Fujitsu Limited.

All Rights Reserved, Copyright © FUJITSU LIMITED 2001

C156-E224-01EN

Revision History

(1/1)

Edition	Date	Revised section (*1) (Added/Deleted/Altered)	Details
01	November, 2001	—	—

1 Section(s) with asterisk () refer to the previous edition when those were deleted.

This page is intentionally left blank.

Preface

This manual describes the MCJ3230SS 90 mm (3.5-inch) optical disk drive.

This manual provides an overview of the above optical disk drives, and explains their specifications, the requirements and procedures for installing them in a system, and how to clean them.

The manual is intended for users who have a basic understanding of optical disk drives and their use in computer systems.

See "Manual Organization" for details of the organization of manuals related to optical disk drives and the scope of this manual. Use the other manuals shown in "Manual Organization" together with this manual when necessary.

The organization of this manual, related reference manual and conventions for alert messages follow.

Overview of Manual

This manual consists of the following six chapters, glossary, and abbreviation:

Chapter 1 General Description

This chapter introduces the MCJ3230SS optical disk drive and describes its features, drive configuration, and system configuration.

Chapter 2 Specifications

This chapter describes the specifications of the MCJ3230SS optical disk drive and the specifications of optical disk cartridges.

Chapter 3 Installation Requirements

This chapter describes the basic environmental, mounting, power supply, and connection requirements for installing the MCJ3230SS optical disk drive in a user system.

Chapter 4 Host Interface

This chapter describes the host interface of the MCJ3230SS optical disk drive.

Chapter 5 Diagnostics and Maintenance

This chapter describes how to operate and clean the MCJ3230SS optical disk drive. This chapter also describes how to operate and clean optical disk cartridges.

Chapter 6 Diagnostics and Maintenance

This chapter describes the self-diagnostics functions and maintenance of the MCJ3230SS optical disk drive.

Glossary

The glossary describes the technical terms that need to be understood to read this manual.

Acronyms and Abbreviations

This manual contains a list of the abbreviations used in this manual and their meanings.

CONVENTIONS USED IN THIS MANUAL

Throughout this manual, the MCJ3230SS optical disk drive are described as an "ODD," "drive," "unit," "target (TARG)," or "device."

Decimal values are indicated without any modifiers added.

Hexadecimal values are indicated as X'17B9', 17B9h, 17B9H, and 17B9H.

Binary values are indicated as "010" and 010b.

Conventions for Alert Messages

This manual uses the following conventions to show the alert messages. An alert message consists of an alert signal and alert statements. The alert signal consists of an alert symbol and a signal word or just a signal word.

The following are the alert signals and their meanings:



This indicates a hazardous situation *likely* to result in *serious personal injury* if the user does not perform the procedure correctly.



This indicates a hazardous situation *could* result in *serious personal injury* if the user does not perform the procedure correctly.



This indicates a hazardous situation *could* result in *minor or moderate personal injury* if the user does not perform the procedure correctly. This alert signal also indicates that damages to the product or other property, *may* occur if the user does not perform the product correctly.

IMPORTANT

This indicates information that could help the user use the product more efficiently.

In the text, the alert signal is centered, followed below by the indented message. A wider line space precedes and follows the alert message to show where the alert message begins and ends. The following is an example:

(Example)



Low temperature burns: The surface temperatures of some ICs on the printed circuit board unit in the optical disk drive exceed 55°C while operating. Be careful of low temperature burns.

The main alert messages in the text are also listed in the “Important Alert Items.”

Attention

Please forward any comments you may have regarding this manual.

To make this manual easier for users to understand, opinions from readers are needed. Please write your opinions or requests on the Comment at the back of this manual and forward it to the address described in the sheet.

DISCLAIMER

Failure of the MCJ3230SS optical disk drive is defined as a failure requiring adjustment, repair, or replacement. Fujitsu is not responsible for failure due to misuse, operation outside the specified environment conditions, power line trouble, controller problems, cable failure, or other failure not caused by the optical disk drive itself.

Important Alert Items

Important Alert Messages

The important alert messages in this manual are as follows:



A hazardous situation *could* result in *minor* or *moderate personal injury* if the user does not perform the procedure correctly. Also, damage to the product or other property, *may* occur if the user does not perform the procedure correctly.

Task	Alert message	Page
	Low temperature burns: The surface temperatures of some ICs on the printed circuit board unit in the optical disk drive exceed 55°C while operating. Be careful of low temperature burns.	3-1
	Device damage: 1) Shock or vibration applied to the drive that exceeds the values defined in the standard damage the drive. Use care when unpacking. 2) Do not leave the drive in dirty or contaminated environments. 3) Since static discharge may destroy the CMOS devices in the drive, pay attention to the following points after unpacking: <ul style="list-style-type: none">- Use an antistatic mat and wrist strap when handling the drive.- Hold the mounting frame when handling the drive. Do not touch the Printed circuit board except when setting the switches. 4) When handling the drive, hold both sides of the mounting frame. When touching other than both sides of the mounting frame, avoid putting force. 5) Do not forcibly push up the end of the header pin of the printed circuit board unit when handling or setting the drive.	3-21

Task	Alert message	Page
	<p>Device damage: Be sure to turn on the power supply before inserting your cartridge for the first time. It releases the device from transport protection and enables you to insert the cartridge. The device may be damaged if you insert the cartridge without releasing the protection. From the next time, you don't need to turn on the power supply beforehand.</p> <p>Before moving the drive, remove the optical disk cartridge. If the drive is moved with the optical disk cartridge loaded in it, the head may move back and forth in the drive to damage the head or disk and reading the data may fail.</p> <ul style="list-style-type: none"> • Make sure that the system power is off. • Do not connect or disconnect any cable when the power is on. <p>Device damage: Before demounting the optical disk drive, turn off the system power. Do not remove screws securing the cables and drive when the power is on.</p>	<p>3-22</p> <p>3-25</p> <p>3-27</p>
	<p>Device Damage: Be sure to use the dedicated head cleaner described above.</p> <p>Damage for data medium: Do not use this cleaning kit for the floppy disk or the optical disk cartridge used for other optical disk drive.</p> <p>Damage for disk medium: Clean the cartridge at clean place. Put a disposable groves at cleaning so that the fingerprint does not put on the disk media (recommendation).</p> <p>Damage for disk medium: At setting the cartridge to the setting case, do not apply the heavy shock and push hardly.</p> <p>Eye inflammation: In case of contact with eyes, immediately flush eyes with water.</p> <p>Data loss: In case of regular repair, the optical disk cartridge should not be attached except where the cartridge causes the error. And before having the drive repaired, save the data in the cartridge. Fujitsu is not responsible for data lost during maintenance or repair.</p>	<p>5-6</p> <p>5-12</p> <p>5-12</p> <p>5-13</p> <p>5-14</p> <p>6-3</p>

MANUAL ORGANIZATION

OPTICAL DISK DRIVE
PRODUCT MANUAL
(C156-E224)
<This manual>

1. GENERAL DESCRIPTION
2. SPECIFICATIONS
3. INSTALLATION REQUIREMENTS
4. HOST INTERFACE
5. OPERATION AND CLEANING
6. DIAGNOSTICS AND MAINTENANCE

OPTICAL DISK DRIVES
MAINTENANCE MANUAL
(C156-F043)

1. MAINTENANCE AND DIAGNOSIS
2. FAULT ANALYSIS
3. REMOVAL AND REPLACEMENT PROCEDURES
4. PRINCIPLES OF OPERATION
5. CLEANING

REFERENCED STANDARDS

The product specifications and functions described in this manual conform to the following standards:

Specification (document) number	Name	Concerned organization
ANSI X3. 131-1986	American National Standard for Information Systems-Small Computer System Interface. (SCSI)	American National Standards Institute (ANSI)
ANSI X3. 131-1994	American National Standard for Information Systems-Small Computer System Interface-2. (SCSI-2)	American National Standards Institute (ANSI)
ISO/IEC 10090	90mm Optical Disk Cartridges, rewritable and read only, for data interchange.	ISO/IEC *1
ISO/IEC 13963	Data Interchange on 90mm Optical Disk cartridges Capacity: 230 megabytes per cartridges.	ISO/IEC *1
ISO/IEC 15041	Data Interchange on 90mm Optical Disk Cartridges Capacity: 640 megabytes per cartridges.	ISO/IEC JTC1 *1
Cherry Book	GIGAMO 1.3GB 90mm Magneto-Optical Disk System.	FUJITSU LIMITED SONY CORPORATION
Cherry Book 2	GIGAMO 2.3GB 90mm Magneto-Optical Disk System.	FUJITSU LIMITED SONY CORPORATION

*1 ISO= International Organization for Standardization

IEC= International Electrical for Commission

JTC1= Joint Technical Committee 1

Contents

Preface	i
DISCLAIMER	iv
MANUAL ORGANIZATION	vii
CHAPTER 1 General Description	1-1
1.1 Features	1-2
1.1.1 Performance	1-2
1.1.2 Reliability	1-3
1.1.3 Maintainability/operability	1-4
1.1.4 Adaptability	1-4
1.1.5 Interface	1-5
1.2 Drive Configuration	1-7
1.2.1 Drive model	1-7
1.2.2 Configuration	1-8
1.2.3 Mechanical sections	1-9
1.2.4 Control circuit section	1-10
CHAPTER 2 Specifications	2-1
2.1 Optical Disk Drive Specifications	2-1
2.1.1 Model and product number	2-1
2.1.2 Drive specifications	2-2
2.1.3 Environmental and power requirements	2-4
2.1.4 Error rate	2-6
2.1.5 Reliability	2-6
2.2 Optical Disk Cartridge Specifications	2-7
2.2.1 Recommended optical disk cartridge specifications	2-7
2.2.2 Optical disk cartridge	2-8
2.2.3 Disk specifications	2-9

2.3 Defect Management.....2-11
 2.3.1 Defect management schematic diagram2-11

CHAPTER 3 Installation Requirements.....3-1

3.1 Environmental Requirements3-1
 3.1.1 Temperature measurement point3-1
 3.1.2 Temperature requirements and measuring method.....3-3
 3.1.3 Air flow3-3
 3.1.4 Temperature rise under several conditions3-4
 3.1.5 Air purity3-4
 3.2 Mounting Requirements3-5
 3.2.1 External dimensions3-5
 3.2.2 Installation direction3-7
 3.2.3 Centers of gravity3-8
 3.2.4 Notes on mounting.....3-9
 3.3 Power Supply Requirements.....3-11
 3.4 Cable Connections3-12
 3.4.1 Drive connectors.....3-12
 3.4.2 Cable connector specifications3-15
 3.4.3 Connection Modes3-16
 3.5 Settings3-18
 3.5.1 Default jumper settings.....3-18
 3.5.2 Setting terminal.....3-18
 3.6 Notes on Drive Handling3-21
 3.7 Mounting.....3-24
 3.7.1 Checks before mounting the drive3-24
 3.7.2 Mounting procedure3-24
 3.8 Cable Connections3-25
 3.9 Operation Confirmation and Preparation for Use after Installation.....3-26
 3.9.1 Confirming initial operations.....3-26
 3.9.2 Connection check3-27
 3.10 Dismounting Drive3-27

CHAPTER 4 Host Interface 4-1

4.1	Interface Connector	4-1
4.2	Various Processes	4-4
4.2.1	Reset response	4-4
4.2.2	Defective sector management	4-4
4.2.3	Automatic alternate sector assignment function.....	4-4
4.2.4	Cache function.....	4-5
4.2.4.1	Data buffer	4-5
4.2.4.2	Read cache	4-5
4.2.4.3	MO write cache	4-6
4.2.5	Power management function	4-6
4.2.6	Power mode.....	4-6
4.2.6.1	Active mode	4-7
4.2.6.2	Pre-idle mode	4-7
4.2.6.3	Idle mode.....	4-7
4.2.6.4	Standby mode.....	4-7
4.2.6.5	Standby timer	4-7
4.2.6.6	Power mode transition.....	4-8
4.2.7	LED indications.....	4-9
4.3	SCSI Commands	4-10
4.3.1	TEST UNIT READY command	4-11
4.3.2	INQUIRY	4-11
4.3.3	READ CAPACITY command	4-13
4.3.4	MODE SELECT command.....	4-13
4.3.5	MODE SENSE command	4-22
4.3.6	START/STOP UNIT command	4-24
4.3.7	RESERVE command	4-25
4.3.8	RELEASE command.....	4-26
4.3.9	REQUEST SENSE command.....	4-26
4.3.10	PREVENT/ALLOW MEDIUM REMOVAL command	4-31
4.3.11	READ (6) command.....	4-32
4.3.12	READ (10) command.....	4-32
4.3.13	VERIFY command.....	4-33
4.3.14	WRITE (6) command.....	4-33
4.3.15	WRITE (10) command.....	4-34
4.3.16	WRITE AND VERIFY	4-34
4.3.17	SEEK (6) command.....	4-35
4.3.18	SEEK (10) command.....	4-35
4.3.19	ERASE command	4-36
4.3.20	SYNCHRONIZE CACHE command	4-36

4.3.21	FORMAT UNIT command	4-37
4.3.22	READ DEFECT DATA command	4-38
4.3.23	SEND DIAGNOSTIC command.....	4-39
4.3.24	RECEIVE DIAGNOSTIC RESULTS command.....	4-39
4.3.25	WRITE BUFFER command.....	4-40
4.3.26	READ LONG command	4-41
4.3.27	WRITE LONG command.....	4-41
4.4	SCSI Messages	4-42
4.4.1	Message formats	4-42
4.4.2	Message types.....	4-42
4.4.3	Message functions	4-43
4.5	Timing Rule	4-46
CHAPTER 5	Operation and Cleaning	5-1
5.1	Operating Optical Disk Drive	5-1
5.1.1	Optical disk drive.....	5-2
5.1.2	Note	5-3
5.1.3	Inserting cartridge.....	5-3
5.1.4	Ejecting (removing) cartridge.....	5-5
5.2	Cleaning Drive.....	5-6
5.3	Optical Disk Cartridge Operation	5-7
5.3.1	Optical disk cartridge.....	5-7
5.3.2	Write protect tab	5-8
5.3.3	How to affix an index label on the MO cartridge	5-9
5.3.4	Notes	5-9
5.4	Cleaning Optical Disk Cartridge.....	5-11
5.4.1	Cleaning tool	5-11
5.4.2	Cleaning procedure.....	5-12
CHAPTER 6	Diagnosis and Maintenance	6-1
6.1	Diagnosis	6-1
6.1.1	Initial self-diagnosis	6-1
6.1.2	Diagnostic command	6-2
6.1.3	Test program.....	6-2

6.2 Maintenance Information6-3
6.2.1 Maintenance requirements6-3
6.2.2 Revision number6-4

Glossary**GL-1**

Abbreviations**AB-1**

Index**IN-1**

Illustrations

Figures

Figure 1.1	Outer view (with panel)	1-7
Figure 1.2	Outer view (without panel)	1-7
Figure 1.3	Optical disk drive configuration	1-8
Figure 1.4	Control circuit section block diagram.....	1-10
Figure 2.1	Optical disk cartridge.....	2-8
Figure 2.2	Algorithms for alternate processing.....	2-11
Figure 2.3	Example of alternate processing	2-12
Figure 3.1	Surface temperature measurement points	3-2
Figure 3.2	Dimensions	3-5
Figure 3.3	Dimensions (without panel).....	3-6
Figure 3.4	Installation directions.....	3-7
Figure 3.5	Centers of gravity.....	3-8
Figure 3.6	Mounting frame structure	3-9
Figure 3.7	Service clearance	3-10
Figure 3.8	Current waveform (+5 VDC).....	3-11
Figure 3.9	Connector and terminal locations	3-12
Figure 3.10	Location of setting terminal.....	3-12
Figure 3.11	Shape of setting terminal	3-13
Figure 3.12	SCSI bus connection modes	3-16
Figure 3.13	SCSI bus connection modes	3-17
Figure 3.14	Setting terminal (CNH2)	3-18
Figure 3.15	Packing style.....	3-23
Figure 4.1	SCSI interface connector (ODD side).....	4-1
Figure 4.2	SCSI interface connector (cable side).....	4-2
Figure 4.3	Power mode	4-8
Figure 4.4	BUS FREE phase.....	4-49
Figure 4.5	ARBITRATION phase	4-50
Figure 4.6	SELECTION phase.....	4-51
Figure 4.7	RESELECTION phase.....	4-51
Figure 4.8	Transfer in asynchronous mode	4-52
Figure 4.9	Transfer in FAST SCSI mode.....	4-53
Figure 4.10	ATTENTION condition.....	4-54
Figure 5.1	Optical disk drive front view (with panel).....	5-2
Figure 5.2	Inserting cartridge	5-4
Figure 5.3	Removing cartridge.....	5-5
Figure 5.4	Optical disk cartridge.....	5-7
Figure 5.5	Write protect tab	5-8
Figure 5.6	How to stick an index label on the MO cartridge	5-9
Figure 5.7	Cleaning procedure (1)	5-12
Figure 5.8	Cleaning procedure (2)	5-13
Figure 5.9	Cleaning procedure (3)	5-13
Figure 5.10	Cleaning procedure (4)	5-14

Figure 6.1	Revision label	6-4
Figure 6.2	Revision number indication.....	6-4

Tables

Table 2.1	Model and order number.....	2-1
Table 2.2	Specifications (1 of 2).....	2-2
Table 2.2	Specifications (2 of 2).....	2-3
Table 2.3	Environmental and power requirements (1 of 2)	2-4
Table 2.3	Environmental and power requirements (2 of 2)	2-5
Table 2.4	Power consumption in power save mode when the temperature inside the drive is 20°C or lower	2-5
Table 2.5	Recommended optical disk cartridge specifications	2-7
Table 2.6	Disk specifications	2-10
Table 3.1	Temperature requirements at measurement points	3-3
Table 3.2	Temperature at each measuring point (Reference)	3-4
Table 3.3	Pin assignments.....	3-14
Table 3.4	Recommended components for connection	3-15
Table 3.5	SCSI ID setting (CNH2)	3-18
Table 3.6	SCSI terminating resistor mode	3-19
Table 3.7	Write cache mode setting.....	3-19
Table 3.8	Spindle motor automatic stop mode setting.....	3-20
Table 4.1	SCSI interface connector pin assignments (single-ended type).....	4-3
Table 4.2	LED indications	4-9
Table 4.3	SCSI commands.....	4-10
Table 4.4	TEST UNIT READY command.....	4-11
Table 4.5	INQUIRY command.....	4-11
Table 4.6	INQUIRY command response data	4-12
Table 4.7	READ CAPACITY command.....	4-13
Table 4.8	READ CAPACITY data	4-13
Table 4.9	MODE SELECT command	4-13
Table 4.10	Mode page codes	4-14
Table 4.1	Mode parameter list	4-14
Table 4.12	Mode parameter header.....	4-14
Table 4.13	Block descriptor.....	4-15
Table 4.14	Mode page.....	4-15
Table 4.15	Read/write error recovery page.....	4-15
Table 4.16	Variable values in the read-write error recovery page.....	4-16
Table 4.17	Default values in the read-write error recovery page.....	4-16
Table 4.18	Flexible disk page	4-17
Table 4.19	Variable values in the flexible disk page	4-18
Table 4.20	Default values in the flexible disk page	4-18
Table 4.21	Caching page.....	4-19
Table 4.22	Variable values in the Caching Page	4-19
Table 4.23	Default values in the Caching Page	4-19
Table 4.24	Power condition page.....	4-19
Table 4.25	Variable values in the Power condition page.....	4-20
Table 4.26	Default values in the Power condition page.....	4-20
Table 4.27	Verify control page	4-20
Table 4.28	Verify mode	4-21
Table 4.29	Variable values in the Verify control page	4-21
Table 4.30	Default values in the Verify control page	4-21

Table 4.31	MODE SENSE command.....	4-22
Table 4.32	Page control field.....	4-22
Table 4.33	Mode parameters	4-23
Table 4.34	Mode Parameter Header	4-23
Table 4.35	Block Descriptor.....	4-23
Table 4.36	Mode Page	4-24
Table 4.37	START/STOP UNIT command	4-24
Table 4.38	Start, stop, and eject processing.....	4-24
Table 4.39	RESERVE command.....	4-25
Table 4.40	RELEASE command.....	4-26
Table 4.41	REQUEST SENSE command	4-26
Table 4.42	Request Sense Data	4-27
Table 4.43	Error Code	4-27
Table 4.44	Sense Key	4-28
Table 4.45	Logical track address format	4-28
Table 4.46	ASC and ASCQ definitions	4-29
Table 4.47	Format progress indication bytes.....	4-30
Table 4.48	PREVENT/ALLOW MEDIUM REMOVAL command.....	4-31
Table 4.49	Responses to Prevent, Allow, and Eject	4-31
Table 4.50	CDB of READ (6) command	4-32
Table 4.51	READ (10) command.....	4-32
Table 4.52	VERIFY command.....	4-33
Table 4.53	CDB of WRITE (10) command.....	4-33
Table 4.54	WRITE (10) command	4-34
Table 4.55	WRITE AND VERIFY command.....	4-34
Table 4.56	SEEK (6) command.....	4-35
Table 4.57	SEEK (10) command.....	4-35
Table 4.58	ERASE command.....	4-36
Table 4.59	SYNCHRONIZE CACHE command.....	4-36
Table 4.60	FORMAT UNIT command	4-37
Table 4.61	FORMAT UNIT parameter list	4-37
Table 4.62	Defect List Header.....	4-37
Table 4.63	READ DEFECT DATA command	4-38
Table 4.64	Defect List Format of READ DEFECT DATA (10) command	4-38
Table 4.65	Defect list header of READ DEFECT DATA (10) command	4-38
Table 4.66	Defect descriptor.....	4-39
Table 4.67	Sector address format	4-39
Table 4.68	SEND DIAGNOSTIC command.....	4-39
Table 4.69	RECEIVE DIAGNOSTIC RESULTS command.....	4-39
Table 4.70	WRITE BUFFER command.....	4-40
Table 4.71	READ LONG command	4-41
Table 4.72	WRITE LONG command.....	4-41
Table 4.73	Types of messages provided by ODD	4-42
Table 4.74	Transfer mode settings requested by INIT to ODD.....	4-45
Table 4.75	Timing specifications (1 of 3).....	4-46
Table 4.75	Timing specifications (2 of 3).....	4-47
Table 4.75	Timing specifications (3 of 3).....	4-48
Table 4.76	FAST SCSI Timing specifications	4-49
Table 5.1	Head cleaner	5-6
Table 5.2	Cleaning kit.....	5-11
Table 5.3	Packed items (cleaning kit).....	5-11
Table 6.1	Self-diagnostic function.....	6-1

This page is intentionally left blank.

CHAPTER 1 General Description

- | |
|--|
| <ul style="list-style-type: none">1.1 Features1.2 Drive Configuration |
|--|

This chapter describes the features and configuration of the optical disk drives.

The MCJ3230SS (hereafter, the optical disk drive) is the successor model to the MCE3130SS. This optical disk drive, which maintains compatibility with the MCE3130SS, offers high performance and high capacity. Supporting 2.3 GB of storage capacity, this device delivers superior performance with a 5,455-rpm rotational speed, and supports security functions.

The optical disk drive is high-performance, 90 mm (3.5-inch) commutative rewritable optical disk drive which incorporates an SCSI controller.

The interface connecting the optical disk drive to the host system complies with the SCSI-2.

The flexibility and expandability through SCSI I/F, the high performance of the optical disk drive, and the drive's commands set enable the user to construct high-reliability, high-performance disk subsystems with advanced functions and large-scale storage.

1.1 Features

This section describes the following drive features:

- Performance
- Reliability
- Maintainability/operability
- Adaptability
- Interface

1.1.1 Performance

- (1) Half-height standard 90 mm (3.5-inch) size (25.4 mm height)

The SCSI controller can be connected to the system SCSI bus. The controller meets the specifications of the standard 25.4 mm height 90 mm (3.5-inch) fixed disk drive form factor.

- (2) 2.3 GB capacity

The optical disk drive conforms to the 2.3 GB GIGAMO standard. It also supports read and write accesses to 128 MB, 230 MB, 540 MB, 640 MB, and 1.3 GB disks.

- (3) High-speed data transfer

The optical disk drive supports a disk media rotational speed of 3,637 rpm when using 2.3 GB disks. The device supports a rotational speed of 5,455 rpm (ZCAV) when using a 128 MB, 230 MB, 540 MB, or 640 MB disks. When using 1.3 GB disks, the optical disk drive supports ZCAV mode with a rotational speed of 3,637 rpm, and ZCLV mode that controls the speed at three levels: 3,637/4, 138/4,801 rpm, in accordance with the position of the optical head.

In ZCLV mode, the optical disk drive speeds up by detecting continuous accessing of inner disk tracks to prevent a reduction of inner disk rotation.

For random accesses, the optical disk drive switches to ZCAV mode that is fixed to 3,637 rpm to prevent access performance degradation.

In the disk unit, high-speed data transfers at rates of 4.62 to 8.26 MB/s (2.3 GB) are realized. The maximum data transfer rate on the SCSI bus is 20 MB/s in synchronous transfer mode.

The SCSI bus high-speed data transfer capacity can be used effectively through the optical disk unit's large capacity data buffer.

(4) High-speed mean seek time

This drive features a linear voice-coil motor for high-speed head positioning. The average seek time is the average of 1,000 random seeks and is 19 ms. (However, this does not include command overhead or address check.)

(5) Compatible with international standards (media interchangeability)

90 mm (3.5 inch) type optical disks as well as ISO standards compatible 128 MB, 230 MB, 540 MB and 640 MB format optical disk media can be used in the optical disk unit.

(6) Direct-overwrite medium support

The drive can use an optic modulation direct-overwrite disk that does not perform an erase operation; 230-MB disk, 540-MB disk with the ISO standard.

(7) Dust resistance

The optical disk unit provides low-power consumption, eliminating the need for a cooling fan. The top of the cartridge is sealed with film, and the bottom of the optical disk unit is sealed with sheet metal, providing protection that is not complicated.

The optical disk drive needs class 5 millions or less of the dust particles.

(8) Lower power consumption

The power consumption of the optical disk drive is 6.5 W (These power consumption values are typical values during read and write operation.) These drives do not use a fan.

The minimum power consumption is 1.0 W (typical value) during power save.

(9) Automatic spindle stop function

If access is not made within a certain time, this function stops disk rotation to minimize dust accumulation on the disk. This function can be set that time by the MODE SELECT command.

1.1.2 Reliability

(1) Mean time between failures (MTBF)

This drive features a 120,000 hour MTBF.

(2) Error recovery

For the error depending on the optical disk drive, recovery process is made by a suitable retry. This drive features Reed-Solomon error correction (ECC) to assure error-free operation.

(3) Automatic allocation of alternate data blocks

This drive features a function which automatically allocates alternate data blocks to defective data blocks detected while data is being read from or written to an optical disk.

1.1.3 Maintainability/operability

(1) Diagnostic function

This drive has a diagnostic function to check optical disk drive operations. The diagnostic function facilitates test and restoration.

(2) Five-year service life (no overhaul)

This drive will not require overhaul within the first five years of installation if appropriately handled, maintained, and cleaned as recommended.

1.1.4 Adaptability

(1) Wide operating environment

An LSI circuits reduce power consumption. This drive features a wide operating environment (5 to 45°C, general office environment). Dust particles are class 5 millions or less.

(2) Vibration resistance (shock resistance)

Rubber vibration isolators protect the drive against external shock or vibration.

(3) Safety standards

- UL1950 (U.S.A., safety)
- CDRH class 1 (U.S.A., laser)
- CSA C22.2 No. 950 (Canada, safety)
- EN60950 (Europe, safety)
- EN60825 Class 1 (Europe, laser)

(4) Various radio wave standards

This optical disk device is installed in a host system, and meets the following standards:

- EN55022 class B, EN55024 (European wave standards)
- AS/NZS3548 class B (Australian wave standards)
- CNS13438 (Taiwanese radio interference standard)

1.1.5 Interface

(1) Conformance to SCSI-2

This optical disk device supports the basic functions of SCSI-2.

SCSI commands enable data manipulation using logical block addresses that are independent of the physical attributes of the optical disk device, enabling software flexibility in terms of system expansion in the future.

(2) Continuous block processing

Logical block addresses are used for data block addressing. Without consideration of the physical attributes of track boundaries, the host can access data by specifying a block number in logically continuous data space.

(3) Data buffer

7,600 KB buffer is used to transfer data between the SCSI bus and disk. Since data is stored in this buffer, the host can execute input-output processing effectively by using the high-speed data transfer capability of the SCSI bus without regard to the data transfer rate of the optical disk drive.

(4) Read-ahead cache feature

The read-ahead cache feature enables high-speed sequential data access as follows:

After executing a command to read data from the disk, the drive automatically reads the next data block and stores it in the data buffer (pre-reading). If the next command requests this data, the data is transferred from the buffer without another disk access.

(5) Write cache feature

When the host system issues the write command to the optical disk drive, a command complete is usually responded after completion of the write and verify operations. By using the write cache feature, a command complete is responded after completion of the data transfer to the data buffer without waiting the completion of the write and verify operations then the write and verify operations are made asynchronously with the interface operation. Therefore, the apparent write command processing time measured at the host system is reduced and the I/O performance of the host system is improved.

The write cache feature is enabled or disabled by MODE SELECT command.

IMPORTANT

When the write cache feature is enabled, a write error is reported at the completion status of next command. At a system so that the host retries the command, a retry process may be failed.

(6) Defective block slipping

When a disk is initialized, logical data blocks are reallocated in a physical sequence by slipping defective data blocks. This enables high-speed continuous data block processing without rotational delay due to defective data blocks.

(7) Device driver software

The optical disk drive requires more extended processing time than conventional optical device drives because of higher density. Consequently, a processing time timeout when using the OS can occur and this requires special device driver software.

1.2 Drive Configuration

1.2.1 Drive model

Figures 1.1 and 1.2 show the outer view.

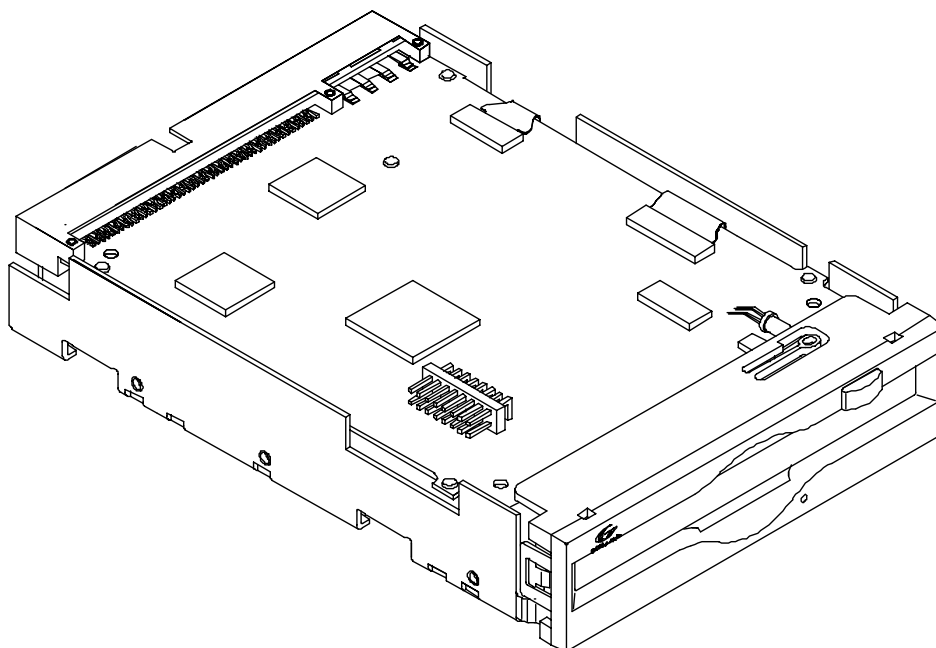

Figure 1.1 Outer view (with panel)

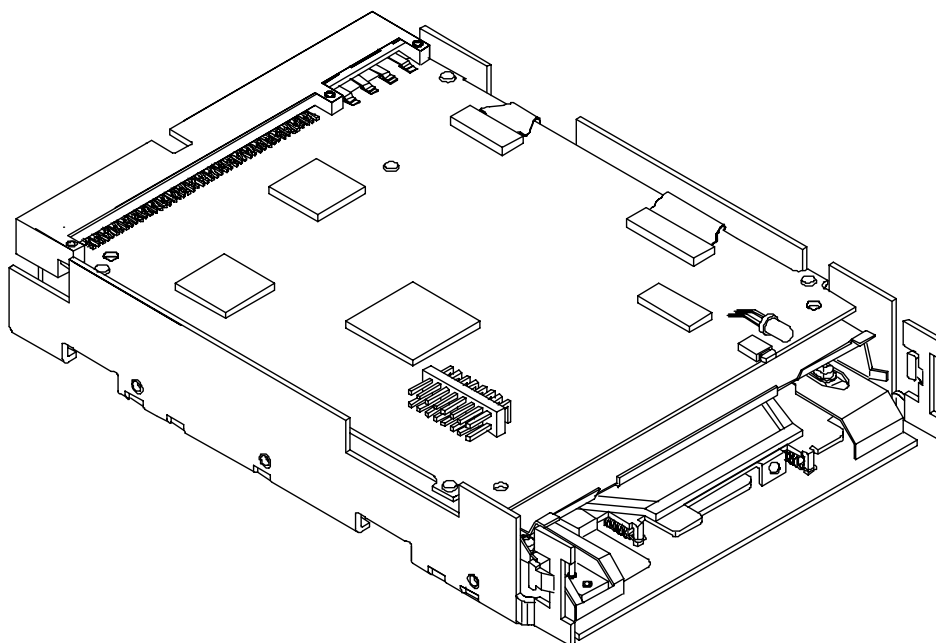

Figure 1.2 Outer view (without panel)

1.2.2 Configuration

Figure 1.3 shows the drive configuration.

The drive consists of mechanical sections, a fixed optics section, actuator, and a control circuit section. The mechanical sections include the spindle motor, actuator section, bias magnet, and the cartridge folder vertical motion mechanism.

The fixed optics section consists of the optical components, position detector, and LD controller.

The control circuit sections include the drive control circuit section and SCSI controller section.

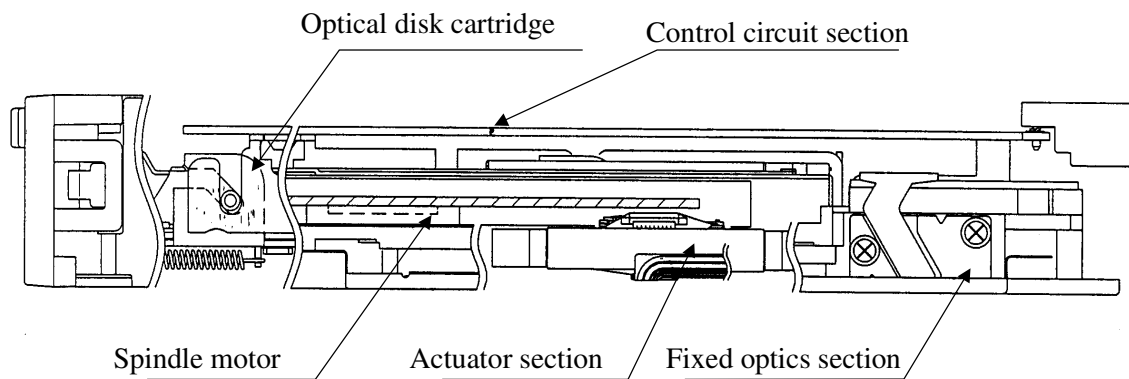

Figure 1.3 Optical disk drive configuration

1.2.3 Mechanical sections

(1) Optical disk cartridge load/eject

The system includes a cartridge mechanism which lowers the optical disk cartridge and mounts (loads) it on the spindle motor automatically when the optical disk cartridge is fully inserted in the optical disk drive's disk slot, and a mechanism which automatically ejects the cartridge when the Eject button on the front panel is pressed.

(2) Spindle motor

Optical disk cartridge hubs are linked through magnetic clamps to minimize slippage between the spindle motor shaft and disk. The spindle motor is the direct drive type which rotates the disk at the same speed as the spindle motor shaft. A DC brushless spindle motor is used. The spindle motor rotates at $5,455 \text{ rpm} \pm 0.1\%$.

(3) Actuator section

The positioner moves (seeks) a head actuator radically across the disk surface.

The positioner is driven by a linear voice coil motor. A pulse-width modulation (PWM) is adopted as a driving system and realizes low power consumption and high-speed access.

(4) Separate optical sections

The optical head section is separated in such a way that the fixed optics section is separated from the moving optics section to minimize seek time and positioning error. (See Subsection 1.2.4 for the fixed optical section.) This reduces the weight of the moving parts.

The fixed optics section consists of the laser diodes, collimator lens, and optical detector.

The fixed optics section includes a laser diode for recording and playback, and transmits one laser beam to the head actuator.

(5) Panel

The central part of the panel is hollowed out deeply to provide pushing finger space for inserting the cartridge, thereby facilitating the insertion.

The panel is also simply designed by making the eject button and LED light emitting part integral with each other.

1.2.4 Control circuit section

Figure 1.4 is the block diagram of the control circuit section.

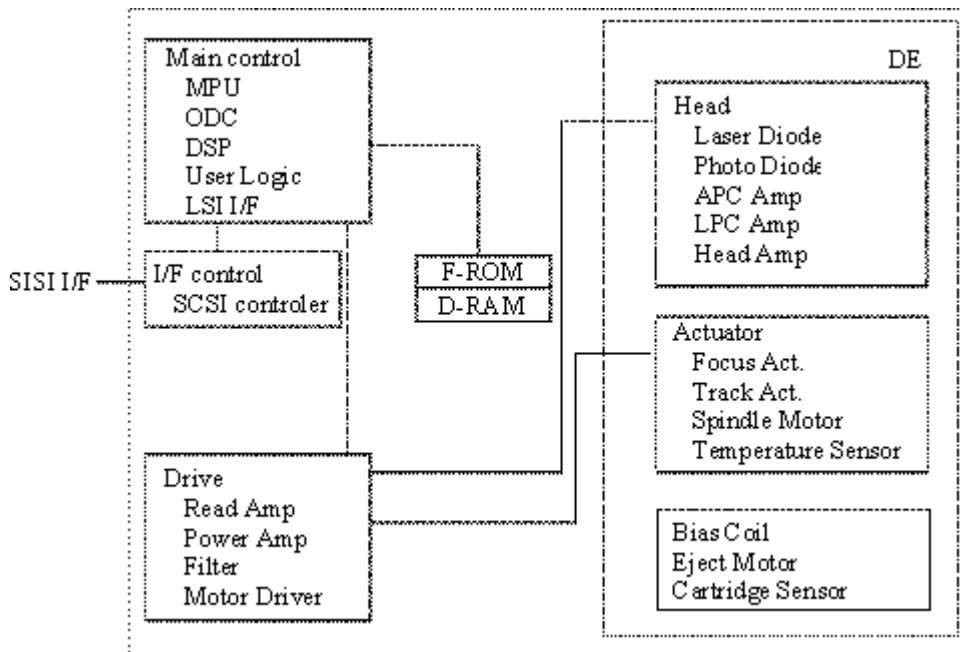

Figure 1.4 Control circuit section block diagram

The control circuit section is divided into two parts: a controller section which deals with control between the SCSI interface and drive interface, and a drive circuit section which controls the drive.

(1) Controller circuit section

The controller circuit's reliability is improved by large-scale integrated circuit technology. The high-speed microprocessor (MPU) handles SCSI interface control and drive control such as drive read-and-write control and single-beam control.

(2) Drive circuit section

The drive circuit section consists of the following circuits:

- Laser diode control circuit
- Signal reproduction circuit
- Servo/seek control circuit
- Rotation control circuit
- Drive miscellaneous control circuit

The DSP (digital signal processor) is used for the servo/seek control circuit to reduce the circuit amount, therefore this circuit is a simple configuration.

The drive circuit section executes operations such as seek, erase, record, and playback while the MPU controls the focus-tracking of the beam.

This page is intentionally left blank.

CHAPTER 2 Specifications

- 2.1 Optical Disk Drive Specifications
- 2.2 Optical Disk Cartridge Specifications
- 2.3 Defect Management

This chapter contains the specifications of the optical disk drive, and the optical disk cartridge.

2.1 Optical Disk Drive Specifications

2.1.1 Model and product number

Table 2.1 lists the model and order number.

Table 2.1 Model and order number

Model Name	Order No.	Panel	Panel Color	Mounting Screws
MCJ3230SS	CA05890-B001	with panel	Light gray (2.5Y 7.2/0.4)	Metric screws (M3)
	CA05890-B201	without panel	—	Metric screws (M3)
	CA05890-B101	with panel	Light gray (2.5Y 7.2/0.4)	Metric screws (M3)

Note: The panel colors (2.5Y 7.2/0.4) are indicated in Munsell symbols. (JIS Z8721)

2.1.2 Drive specifications

Table 2.2 lists MCJ3230SS drive specifications

Table 2.2 Specifications (1 of 2)

Item		Specifications					
Optical disk cartridge		128 MB media	230 MB media	540 MB media	640 MB media	1.3 GB media	2.3 GB media
Total capacity	Unformatted	181 MB	325 MB	819 MB	818 MB	1.683 GB	2.901 GB
	Formatted	128 MB	230 MB	538 MB	643 MB	1.283 GB	2.261 GB
Capacity/track	Unformatted	18,100 bytes	18,100 bytes (logical track capacity)	19,450 bytes (logical track capacity)	43,928 bytes (logical track capacity)	45,798 bytes (logical track capacity)	47,022 bytes (logical track capacity)
	Formatted	12,800 bytes	12,800 bytes (logical track capacity)	12,800 bytes (logical track capacity)	34,816 bytes (logical track capacity)	34,816 bytes (logical track capacity)	34,816 bytes (logical track capacity)
Capacity/sector	Unformatted	725 bytes	778 bytes	778 bytes	2,584 bytes	2,694 bytes	2,766 bytes
	Formatted	512 bytes			2,048 bytes		
Number of user tracks/side *1		10,000	17,940	42,042	18,480	36,855	64,944
Number of alternate sectors/side		≤ 1,024	≤ 1,025	≤ 2,250	≤ 2,244	≤ 4,437	≤ 8,976
Number of sectors/track		25			17		
Data transfer rate		1.65 MB/s (max.) 0.39 MB/s continuous writing (effective) 1.16 MB/s continuous reading (effective)	2.00 to 3.16 MB/s (max.) 0.47 to 0.75 MB/s continuous writing (effective) 1.40 to 2.23 MB/s continuous reading (effective)	3.45 to 5.94 MB/s (max.) 0.78 to 1.30 MB/s continuous writing (effective) 2.33 to 3.91 MB/s continuous reading (effective)	3.52 to 5.87 MB/s (max.) 0.93 to 1.55 MB/s continuous writing (effective) 2.79 to 4.66 MB/s continuous reading (effective)	3.92 to 6.70 MB/s (max.) 0.99 to 1.70 MB/s continuous writing (effective) 2.98 to 5.09 MB/s continuous reading (effective) 5.17 to 6.70 MB/s (ZCLV max.) continuous writing (ZCLV effective) 1.31 to 1.70 MB/s continuous reading (ZCLV effective) 3.93 to 5.09 MB/s	4.69 to 8.38 MB/s (max.) 1.16 to 2.07 MB/s continuous writing (effective) 3.84 to 6.21 MB/s continuous reading (effective)
Random seek time *2		19 ms (typ)					
Average latency		5.5 ms				8.2 ms 7.2 ms (ZCLV) 6.3 ms (ZCLV)	8.2 ms
Rotational speed		5.455 rpm				3,637 rpm 4,138 rpm (ZCLV) 4,801 rpm (ZCLV)	3,637 rpm
Heads		Positioner + Separate Optical Section					
Positioner type		Linear voice coil motor					
Servo tracking method		ISO continuous servo method					

Table 2.2 Specifications (2 of 2)

Item	Specifications					
	128 MB media	230 MB media	540 MB media	640 MB media	1.3 GB media	2.3 GB media
Density	24,424 bpi (1.04µm/bit) 15,875 tpi	29,308 bpi (0.87µm/bit) 18,275 tpi	52,900 bpi (0.48µm/bit) 23,090 tpi		89,100 bpi (0.285µm/bit) 28,200 tpi	112,474 bpi (0.228µm/bit) 37,910 tpi
Loading time *3	8 sec. (typ)				12 sec. (typ)	14 sec. (typ)
Unloading time *4	4 sec. (typ)					
Load/unload life	20,000					
Host interface	SCSI (SCSI-2 standard)					
Data Transfer Model and rates	Asynchronous transfer			5MB/s		
	Synchronous transfer			20MB/s		
Data buffer	7,600 KB					
Error correction *5	Correctable up to 8-byte/interleave Bit error rate: 10^{-12} or less					

- *1 The number of user tracks indicates the maximum user zone which includes the spare area and slipping area.
- *2 Mathematical average of 1,000 times of seek and does not include command overhead nor track address recognition time. Furthermore, it may depend on the quality of media and drive installation environment.
- *3 Loading time is the time from when the optical disk cartridge is inserted to when the optical disk drive is ready.
- *4 Unloading time is the time from when the eject button is pressed or the eject command is issued to when the optical disk cartridge is ejected.
- *5 The bit error rate must be 10^{-12} or less when a disk whose raw error rate is 10^{-4} or less is used.

2.1.3 Environmental and power requirements

Table 2.3 lists the environmental and power requirements.

Table 2.3 Environmental and power requirements (1 of 2)

Item		Specification
Power requirements	Average	+5 VDC±5%, 1.4 A (2.5 A Max.) *1 Ripple requirement 100mV P-P (DC-1 MHz)
Power consumption (Average)	Ready (active mode)	4.8 W (typical) *2
	Random seek, read/ write	6.5 W (typical) *2
	Physical Format	7.3 W (typical) *2
	Power save mode Pre-idle mode Idle mode Standby mode	4.0 W (typical) *2 2.0 W (typical) *2 1.0 W (typical) *2
Dimensions (W×D×H)	With panel	101.6 × 150.0 × 25.4 mm
	Without panel	101.6 × 148.4 × 25.4 mm
Weight		480 g (with panel)
Environmental requirements	Operating	Temperature: 5 to 45°C *3 (gradient 15°C /h or less) Relative humidity: 10 to 85% (Noncondensing) Max. wet bulb temperature: 29°C or lower
	Non Operating	Temperature: 0 to 50°C Relative humidity: 10 to 85% (Noncondensing) Max. wet bulb temperature: 36°C or lower
	Transport	Temperature: -40 to 60°C (24 hours or less) Temperature: -20 to 60°C (24 hours or more) Relative humidity: 5 to 90% (Non condensing) Max. wet bulb temperature: 41°C or lower
Installation	Tilt angle	-5° to +10° *3
Vibration/ shock	Operating	3.9 m/s ² (5 to 500 Hz, sine sweep) 1.96 m/s ² (5 to 500 Hz, sine sweep AV record/play)
		Shock 19.6 m/s ² (10ms, half-sine pulse)
	Non Operating No cartridge, power ON	9.8 m/s ² (5 to 500 Hz, sine sweep) Shock 49 m/s ² (10 ms, half-sine pulse)
Transport	Shock 490 m/s ² (10 ms, half-sine pulse) Requirement: Packing conditions specified by Fujitsu	

Table 2.3 Environmental and power requirements (2 of 2)

Item		Specification
Altitude	Operating	3,000 m (10,000 ft) or less
	Non Operating	12,000 m (40,000 ft) or less
Ambient for purity	Air flow	Unused *4
	Air purity	General office environment or better (dust particles: Class 5 millions or less)

Note:

- *1 At random seek or read/write. Excluding pulse waveform under 500 us or less.
- *2 It demonstrates in an installation environment of a temperature of 25°C, voltage of 5 V.
See Section 4.4.8 for information on the power management function.
- *3 The efficiency is specified in an environment of a temperature of 25°C and 0° horizontal level placement.
- *4 For details, refer to section 3.1.3 'Air Flow'
 1. Current limiter value for +5 VDC power: 5 A or less
 2. Specifications under transporting condition are under the packaging specified by Fujitsu.
 3. A voltage drop may occur depending on the used power supply or power cable.
 4. If power for the terminators in the other SCSI devices is supplied via an optical disk drive, note that the current of the +5VDC power for the optical disk drive may increase by a maximum of 200 mA. The method of supplying power to terminators cannot be changed.
 5. Table 2.4 lists power consumption in power save mode when the temperature inside the drive is 20°C or lower.

Table 2.4 Power consumption in power save mode when the temperature inside the drive is 20°C or lower

IETM		Power consumption at 20°C or lower
Power consumption in power save mode	Pre-idle mode	4.0W (typ)
	Idle mode	2.0W (typ)
	Standby mode	1.0W(typ)

- 6. If the temperature inside the drive is 14°C or lower, disk access might become longer because the speed of the related mechanisms varies with temperature.

2.1.4 Error rate

Data blocks to be accessed are evenly distributed on the disk. Errors due to disk defects are not included.

(1) Bit error rate after ECC processing

The error rate after ECC processing must be 10^{-12} or less. An optical disk cartridge whose raw error rate is 10^{-4} or less should be used.

(2) Positioning error rate

The positioning error rate must be 10^{-6} or less. (with retry)

2.1.5 Reliability

(1) Mean time between failures (MTBF)

The MTBF is 120,000 hours or more. Failure due to disk errors is not included.

Conditions

- Power-on time: 200 hours/month or less
- LD-on time: 20% or less of power-on time
- Environment Temp.: 25°C

Note:

The MTBF is defined as follows:

$$\text{MTBF} = \frac{\text{total operating time in all fields (hours)}}{\text{number of device failure in all fields}}$$

- Operating time is the total time power is applied.
- Device failures indicate that devices require repair, readjustment, or replacement. Failure due to external factors such as minor defects during device handling, operation outside environmental specifications, power failure, host system errors, and interface cable errors are not included.

(2) Service Life

Under appropriate handling and operation, disk cleaning and optical head cleaning, overhaul of the drive is not required for the first five years.

(3) Data security at power failure

Except for the data of the block to which write operation is in progress, all data on the disk is secure from power failure. This does not apply if power failure occurs during disk initialization (formatting) or defect processing (alternate block allocation).

2.2 Optical Disk Cartridge Specifications

2.2.1 Recommended optical disk cartridge specifications

The following three disk types comply with the specifications.

Table 2.5 shows the specifications of the optical disk cartridge recommended for this optical disk drive. The use of another disk cartridge may lower drive performance.

Table 2.5 Recommended optical disk cartridge specifications

Model	Order number	Figure number
Optical disk cartridge (128 MB)	0242110	CA90002-C010
Optical disk cartridge (230 MB)	0242210	CA90002-C011
Optical disk cartridge (540 MB)	0242410	CA90002-C012
Optical disk cartridge (640 MB)	0242610	CA90002-C013
Optical disk cartridge (1.3 GB)	0242810	CA90002-C015
Optical disk cartridge (2.3 GB)	0242910	CA90002-C030
Overwrite optical disk cartridge (230 MB)	0242310	CA90002-C041
Overwrite optical disk cartridge (540 MB)	0242510	CA90002-C042
Overwrite optical disk cartridge (640 MB)	0242710	CA90002-C043

2.2.2 Optical disk cartridge

Figure 2.1 shows an optical disk cartridge. The figure below shows the cartridge with its shutter open.

- a. Shutter closed

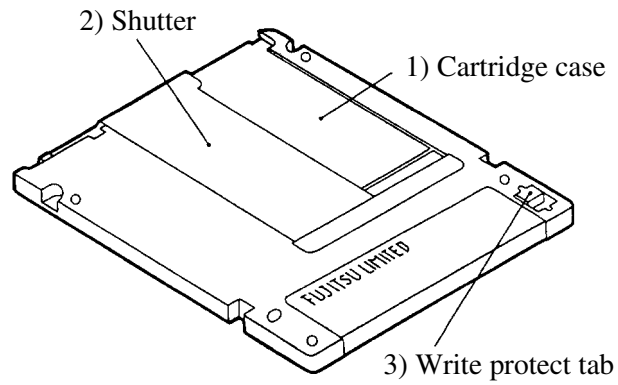

- b. Shutter open

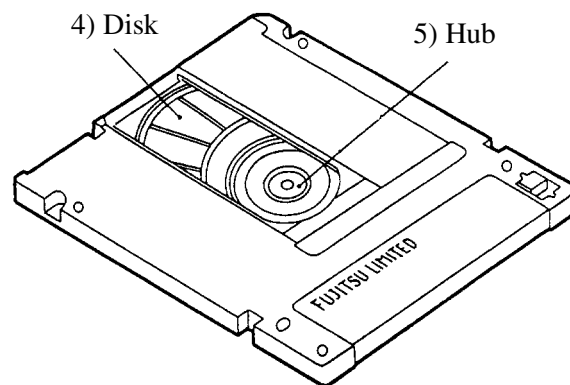

Figure 2.1 Optical disk cartridge

The following explains the components of the optical disk drive shown in Figure 2.1:

1) Cartridge case

Covers the disk to protect it from damage when handled and facilitates disk replacement. The cartridge case is labeled and has a write protect tab.

2) Shutter

Protects the disk against dust. When the cartridge is inserted into the optical disk drive, the shutter (metallic door) is opened.

3) Write protect tab

The write protect tab selects whether write is enabled or disabled.

4) Disk

Holds information which can be read by an optical beam.

5) Hub

The hub is placed at the center of the disk and is linked to the spindle of the drive. The hub is used for radial centering and axial positioning.

2.2.3 Disk specifications

(1) 128 MB disk

The ISO/IEC10090 defines 128 MB disk specification.

(2) 230 MB disk

The ISO/IEC13963 defines 230 MB disk specification.

(3) 540 MB/640 MB disk

The ISO/IEC15041 defines 540 MB/640 MB disk specification.

(4) 1.3 GB disk

The Cherry Book defines 1.3 GB disk specification.

(5) 2.3 GB disk

The Cherry Book 2 defines 2.3 GB disk specification.

Table 2.6 lists disk specifications.

Table 2.6 Disk specifications

	Item	Specification
Reliability	Read cycle	>10 ⁸
	Erase/write/read cycle	>10 ⁶
	Load/unload cycle	25,000
	Archival life (according to acceleration test results)	>10 years *1
	Shelf life (according to acceleration test results)	>10 years *2
Environmental requirements	Operating temperature	5 to 55°C
	Operating relative humidity	3 to 85%RH *3
	Storage temperature	-20 to 55°C
	Storage humidity	3 to 90% RH *3

*1 Archival life is the period in which recorded information can be read.

*2 Shelf life is the period in which information to be recorded can be written.

*3 Maximum wet bulb temperature = 29°C.

Note:

Non-recommended disks must be checked for compatibility.

2.3 Defect Management

2.3.1 Defect management schematic diagram

Defective sectors on the disk shall be replaced by good sectors according to the defect management scheme as follows: Defective sectors found during surface certification are handled by a sector slipping algorithm. Defective sectors found after initialization are handled by a linear replacement algorithm.

Figure 2.2 shows the algorithms for alternate processing.

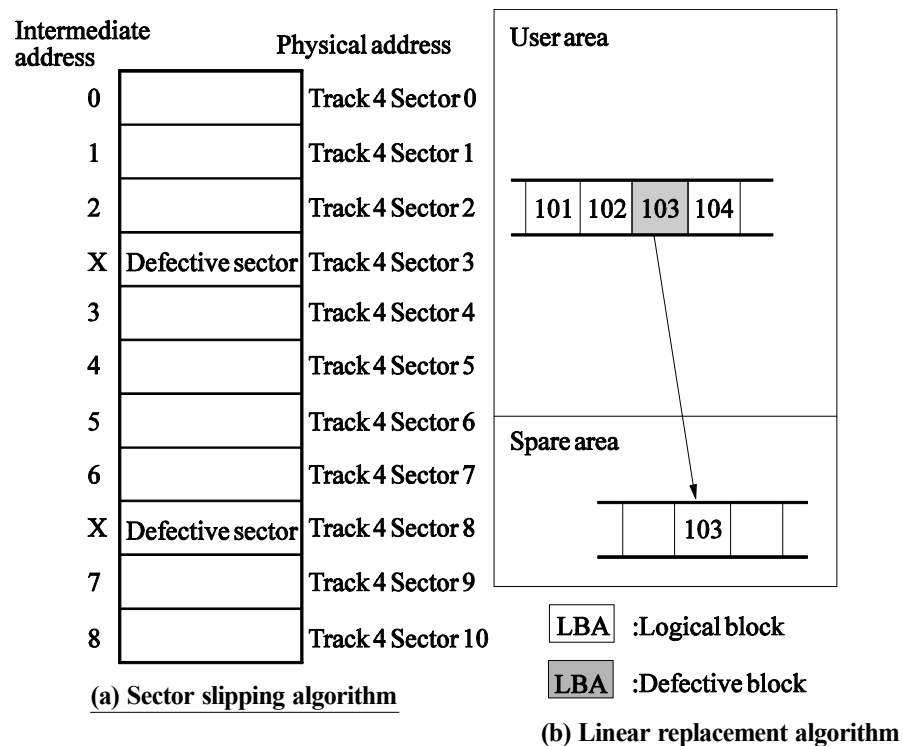
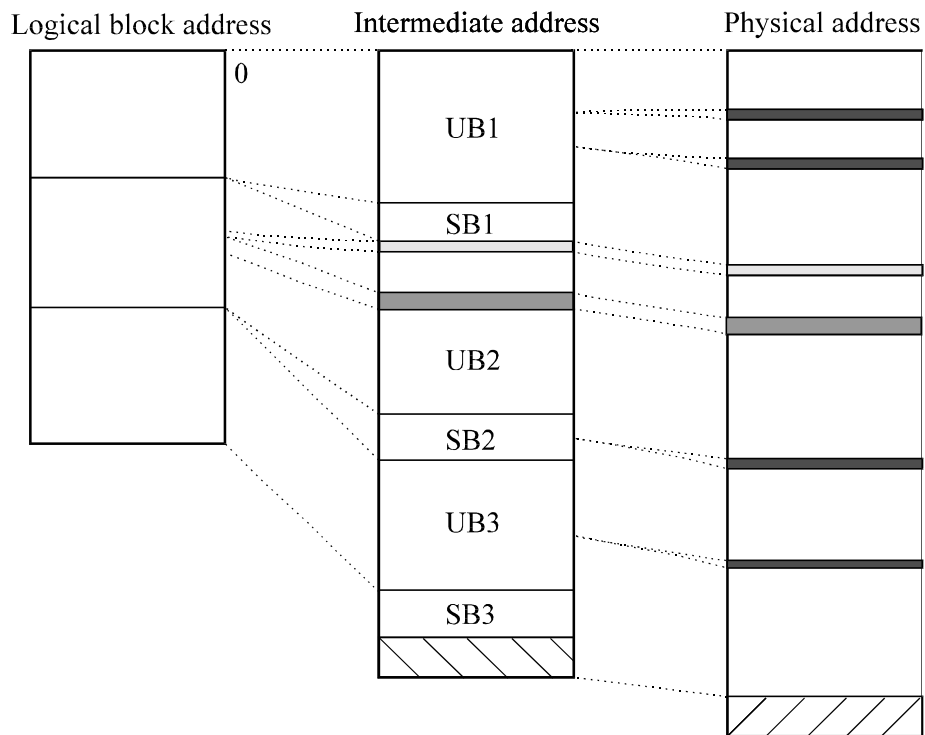

Figure 2.2 Algorithms for alternate processing

The user area is divided into several groups during media initialization. Each group contains data sectors and spare sectors. Spare sectors are used as replacements for defective data sectors. Media initialization can include a certification of the user area.

Figure 2.3 shows an example of alternate processing.



SB: Spare band
 UB: User band





-  Sector resigned by the linear replacement algorithm
-  Defective sector detected by the linear replacement algorithm
-  Defective sector detected by the sector slipping algorithm
-  Slipping area
-  Unused area

Figure 2.3 Example of alternate processing

CHAPTER 3 Installation Requirements

- 3.1 Environmental Requirements
- 3.2 Mounting Requirements
- 3.3 Power supply Requirements
- 3.4 Cable Connections
- 3.5 Settings
- 3.6 Notes on Drive Handling
- 3.7 Mounting
- 3.8 Cable Connections
- 3.9 Operation Confirmation and Preparation for Use after Installation
- 3.10 Dismounting Drive

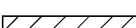
This chapter describes environmental, mounting, power supply, and connection requirements.

3.1 Environmental Requirements

The environment in which these drives are installed must comply with the ambient environmental requirements defined in Subsection 2.1.3.

3.1.1 Temperature measurement point

When a drive is operating, the ambient temperature measured 3 cm from the base surface of the optical disk drive and the PCA unit surface must satisfy the environmental requirements specified in Subsection 2.1.3. For the temperature of each surface during operation, the contact temperature at each measurement point shown in Figure 3.1 must satisfy the requirements specified in Subsection 3.1.2.



Low temperature burns: The surface temperatures of some ICs on the printed circuit board unit in the optical disk drive exceed 55°C while operating. Be careful of low temperature burns.

a) Inside optical disk cartridge

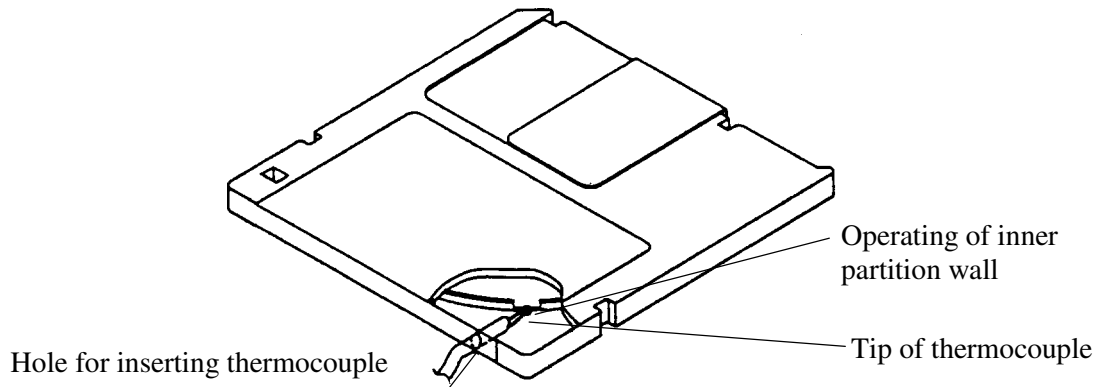

b) IC (controller, read amp)

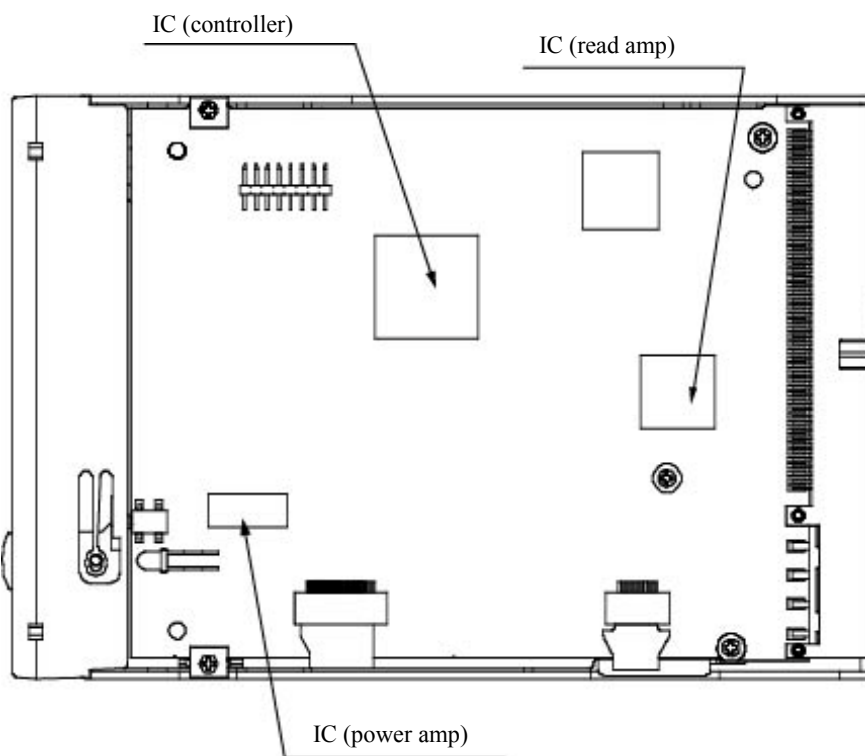

Figure 3.1 Surface temperature measurement points

3.1.2 Temperature requirements and measuring method

Table 3.1 shows the temperature requirement at each measurement point shown in Figure 3.1.

Table 3.1 Temperature requirements at measurement points

Measurement point	Maximum surface temperature
Cartridge inside	55°C *
IC (controller) surface	90 °C
IC (read amp.) surface	95 °C
IC (power amp.) surface	90 °C

* Following procedure is for temperature measurement of inside cartridge.

- 1) Make a hole for the thermocouple as shown in Figure 3.1.
- 2) Disassemble the cartridge disk.
- 3) Cut off a part of the partition wall for the optical media as shown in Figure 3.1. (Cut off width: 5 to 10 mm)
- 4) Fix the tip of the thermocouple to the cut portion of partition wall with an adhesive agent.
- 5) Pass the thermocouple through the hole at the cartridge case and assemble the cartridge disk. When there is a gap between the hole and the thermocouple, fill the gap with the adhesive agent.

Note:

The surface of the cartridge shown in Figure 3.1 has been cut away to make the elements inside the case clearly visible. In reality the surface is not cut away.

If the external environment temperature is higher than the specified value, the device will automatically take an interval to respond to command, and then take protective action to respond to the temperature increase.

3.1.3 Air flow

It is recommended that this optical disk drive be installed in a fanless cabinet. However, if the power supply is incorporated into the same cabinet, it is necessary that it satisfy the "Temperature Conditions" in 3.1.2 and that the air flow rate being drawn in by the device) at the cartridge loading slot be 0.3 m/s or lower. Furthermore, if there is a system fan in a system where this drive is being installed, the same conditions must be met.

3.1.4 Temperature rise under several conditions

Table 3.2 Temperature at each measuring point (Reference)

[Ambient atmospheric temperature of the optical disk drive: 45°C] (°C)

Measurement point	Ready	Random seek	Criteria
Inside cartridge	47°C	54°C	55°C
IC (controller) surface	51°C	68°C	90°C
IC (read amp.) surface	48°C	90°C	95°C
IC (power amp.) surface	47°C	78°C	90°C
Thermal sensor	47°C	55°C	–

Notes:

1. The above data are data estimated as they were measured where the temperature surrounding the equipment was kept at 45 °C, using that at 25 °C. They are not the same as the data obtained from measurements using the exclusive box in which the equipment is normally used.
2. When using the box, the ambient temperature around the equipment will differ depending on the air circulation conditions of the box, and the temperature rise inside the cartridge will differ because of this, so please exercise caution.

3.1.5 Air purity

Air purity in the device environment is expressed by the number of dust particles per unit area and must be class 5 millions (equivalent to 0.15 mg/m³) or less. (Class 5 millions: 5 millions dust particles of 0.5 um dia. or larger per cubic foot)

3.2 Mounting Requirements

3.2.1 External dimensions

Figures 3.2 to 3.3 show the dimensions of the drive and the positions of the mounting holes.

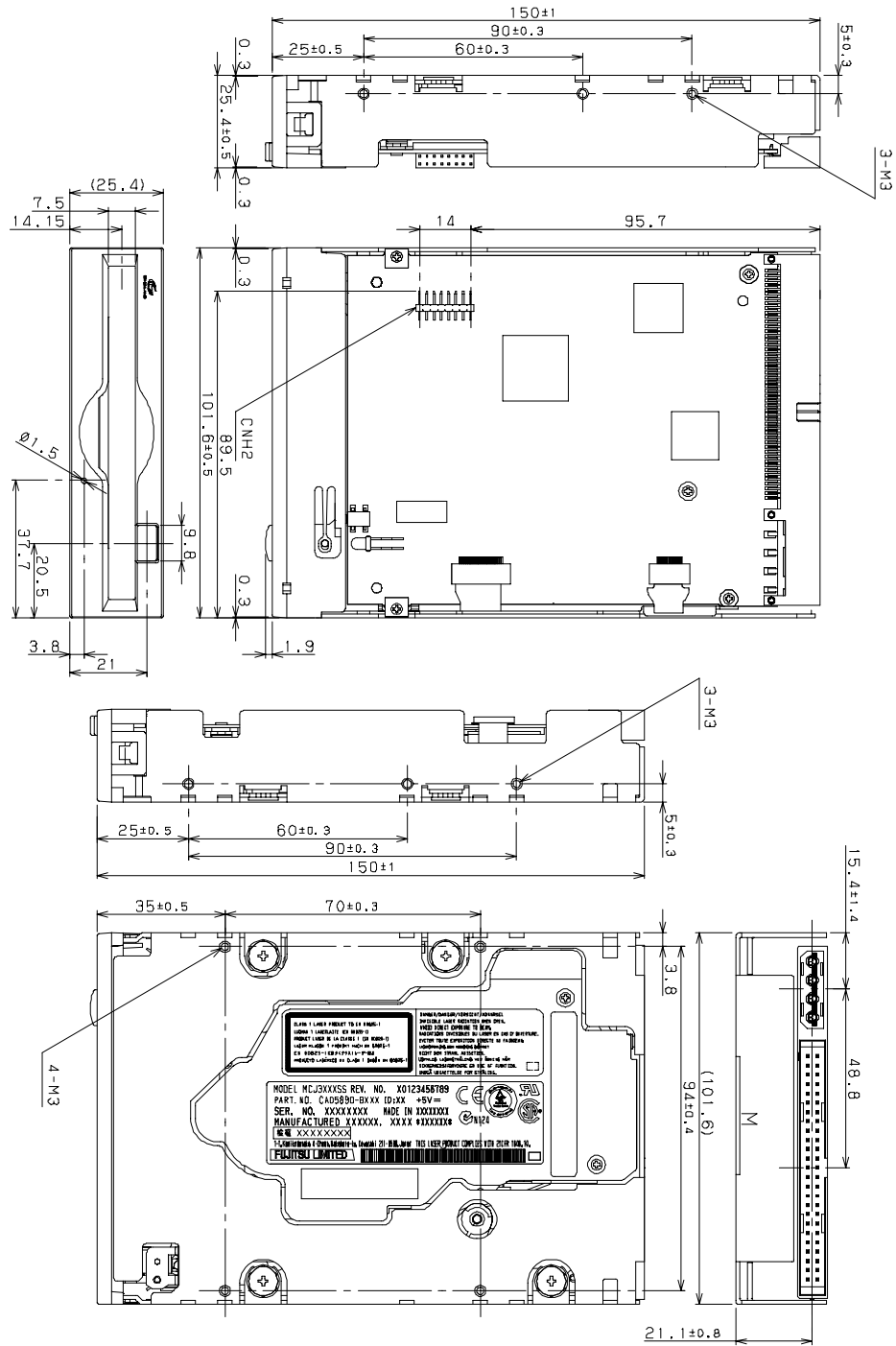

Unit: mm

Figure 3.2 Dimensions

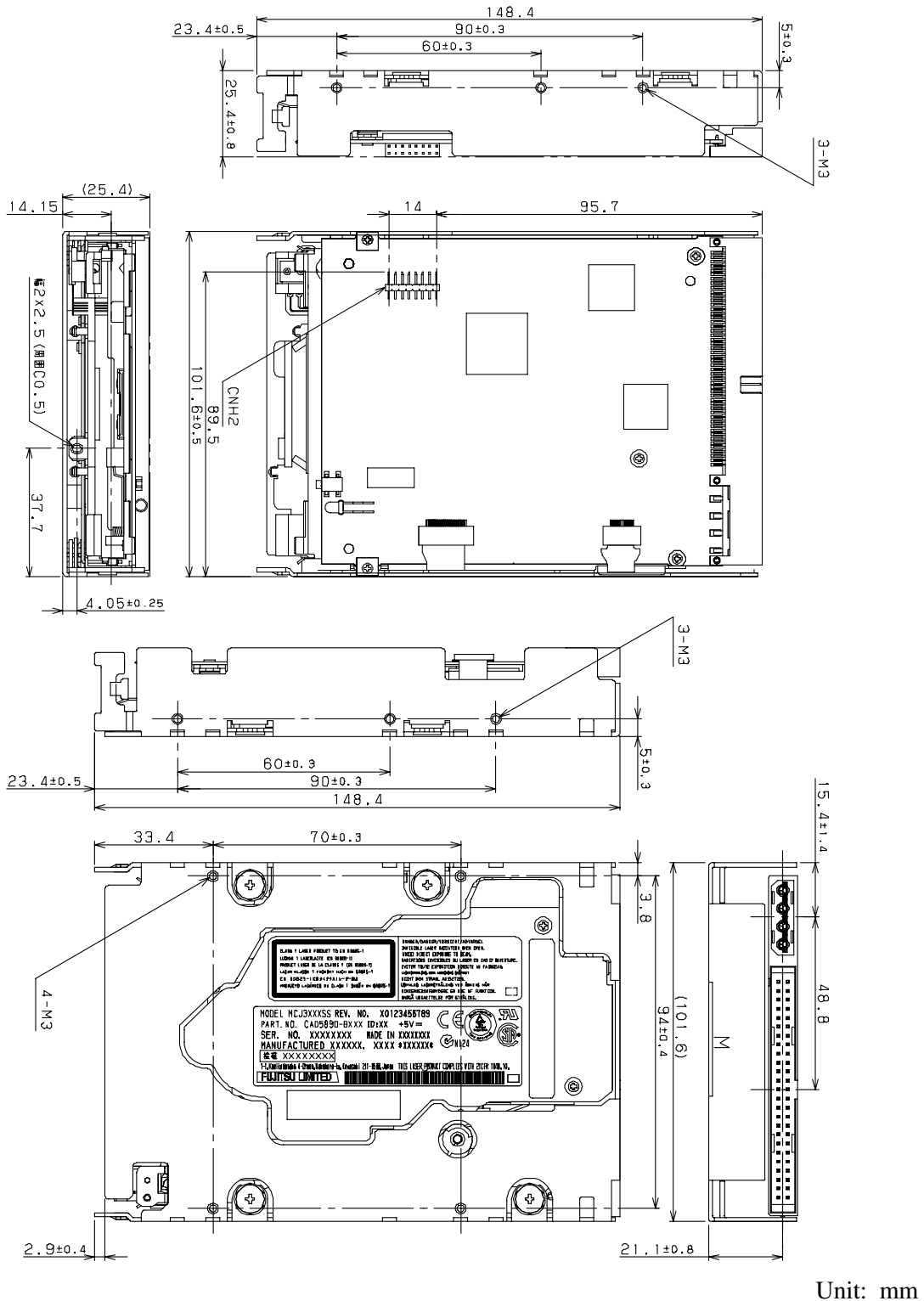
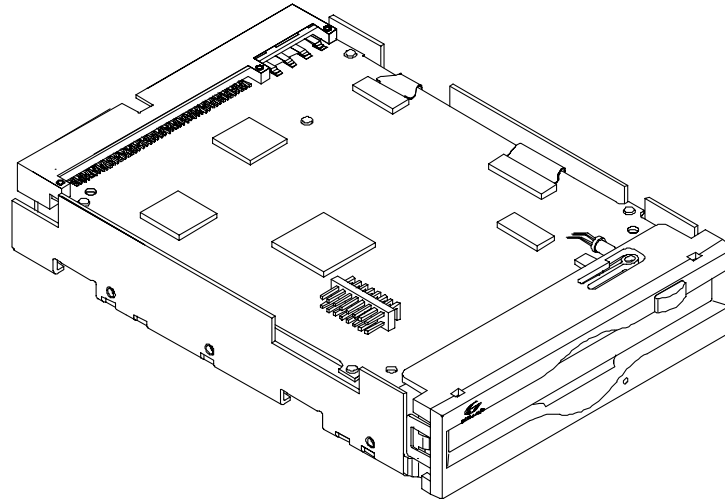

Figure 3.3 Dimensions (without panel)

3.2.2 Installation direction

Figure 3.4 shows the permissible installation directions for this drive. The mounting angle tolerance must be within -5 to 10 from the horizontal. (-) shows that the insertion faces below.



- Horizontal

Disk insertion slot

Eject button / Busy LED

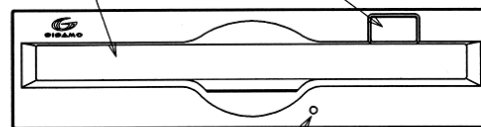

Manual eject hole

- Vertical
(Two orientations)

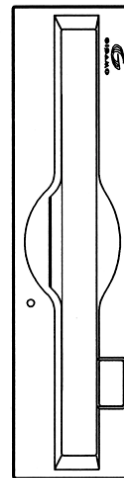
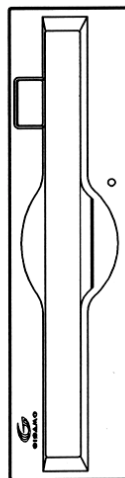

Figure 3.4 Installation directions

3.2.3 Centers of gravity

Figure 3.5 shows the centers of gravity of the drive.

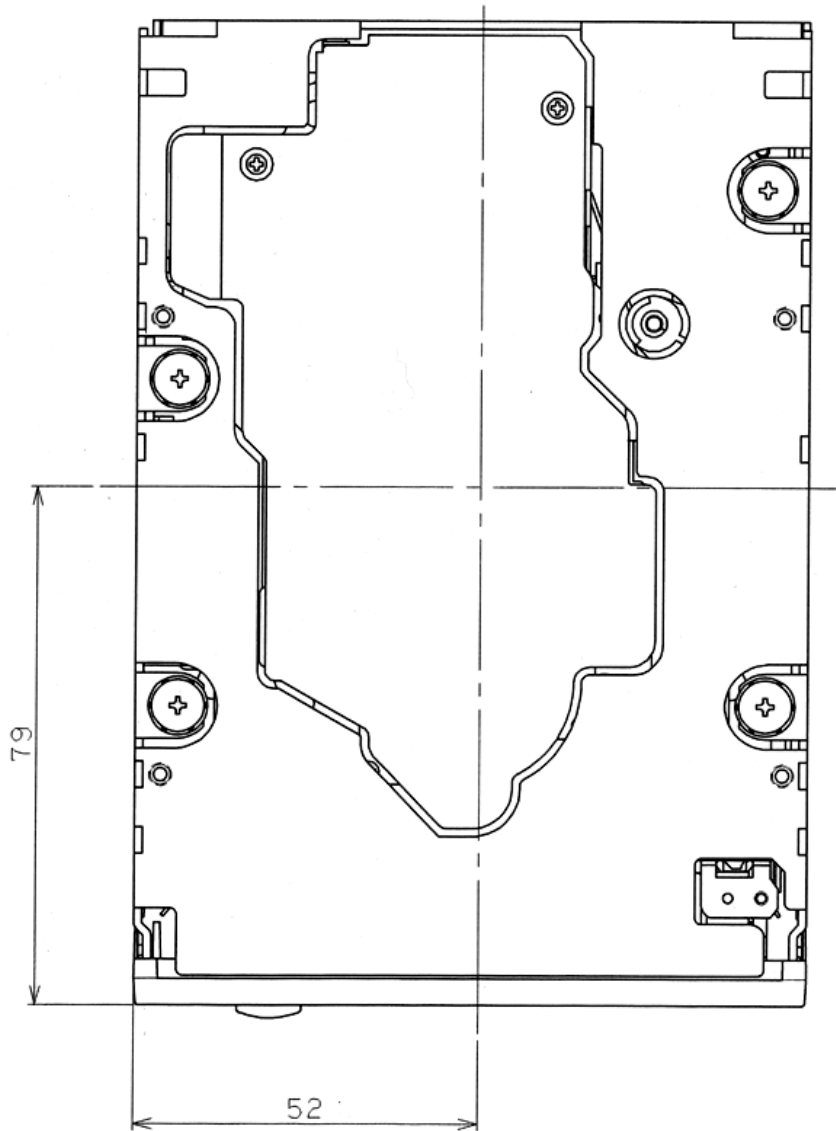

Figure 3.5 Centers of gravity

3.2.4 Notes on mounting

(1) Mounting frame structure and clearance

- a) For vibration resistance and heat dissipation, this optical disk drive uses an embossed structure as shown in Figure 3.6, as well as a frame which has a construction similar to other frames which perform the same function.
- b) As shown in Figure 3.6, the inward projection of the mounting screw from the outer surface of the drive frame must not exceed 3 mm.
- c) The clearance between the external surface of the drive frame and the user's frame structure must be at least 1.5 mm.
- d) The clearance between the top and bottom surfaces and the user's frame structure must be at least 1.5 mm.
- e) When mounting the optical disk drive, the screw tightening torque should be 0.4 to 0.45Nm (4 to 4.6kgcm).
- f) When the optical disk drive (with panel) is mounted in a locker, there should be no deformation of the mounting fittings provided and the optical disk drive's panel should not be deformed. If the drive is used with the panel deformed, ejection of the cartridge will be faulty. Check if the door will close from any position whatever when the optical disk drive is installed.

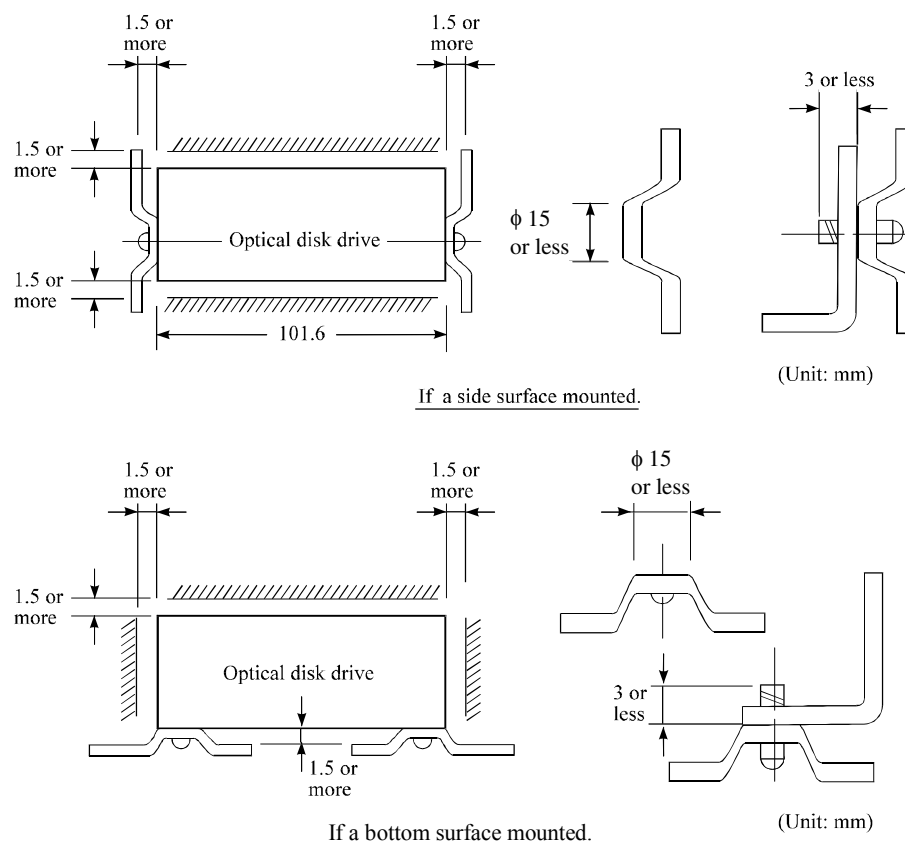

Figure 3.6 Mounting frame structure

(2) Panel function processing

When installed in a cabinet, do not change the panel format. The processing is installation status and the disk insertion door can be closed from any locations.

(3) Service clearance

Figure 3.7 shows locations which must be accessed for installation and maintenance. Be sure to leave sufficient service clearance.

P side

- Cable connection

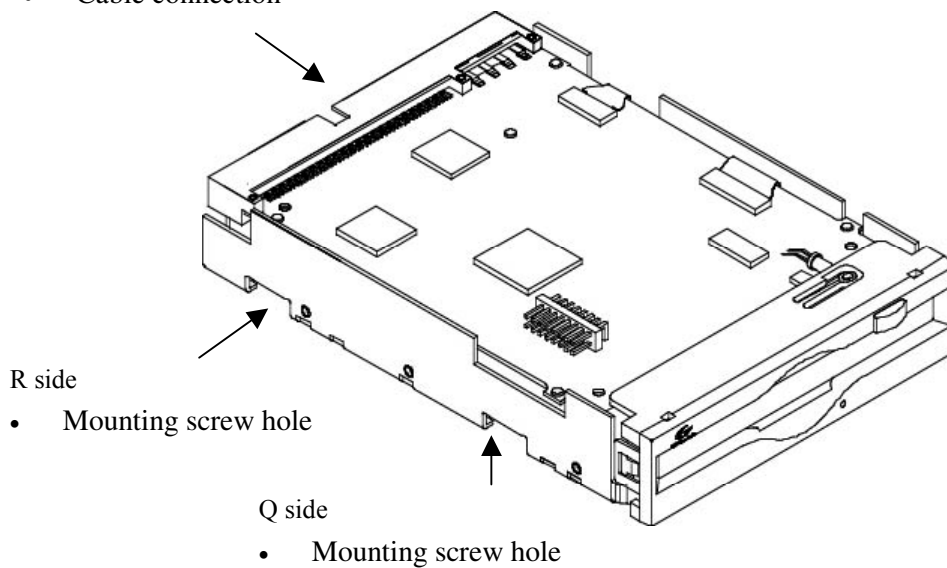

R side

- Mounting screw hole

Q side

- Mounting screw hole

Figure 3.7 Service clearance

(4) External magnetic fields

Mount the optical disk drive away from powerful magnetic materials (e.g., a speaker) to avoid influence from magnetic fields.

(5) Leak magnetic field

The VCM drive magnetic circuit may leak the magnetic field (Maximum 25 mT at distance of 4 mm from the drive).

IMPORTANT

Do not place a device sensitive to a magnetic field near the optical disk drive.

(6) External light source

Mount the optical disk drive away from strong light sources (e.g., camera flash).

(7) System ground

The optical disk drive should be grounded to the signal ground (SG) of the power supply of the system. This SG line should be supplied with the system.

The Frame Ground is shorted in the optical disk drive by a metal strip attached to the vibration isolation rubber between the frame (FG) and the base (SG).

IMPORTANT

When mounting the optical disk drive in the Device Bay 120mm (5 inch) of the PC chassis, there are two ways of choosing frames the metal frame and the plastic (nonconductive material) frame.

When using a plastic frame, there is not a short circuit between FG of PC and FG of the optical disk drive. As a result, the static electricity tolerance decreases compared with metal frame.

It is recommended to use a metal frame to enhance the static electricity prevention.

3.3 Power Supply Requirements

(1) Allowable input voltage and current

The DC power supply input voltage measured at the power supply connector pin of the optical disk drive (receiving end) must satisfy the requirements in Section 2.1.3.

(2) Current waveform (reference)

Figure 3.8 shows the +5 VDC waveform at seek.

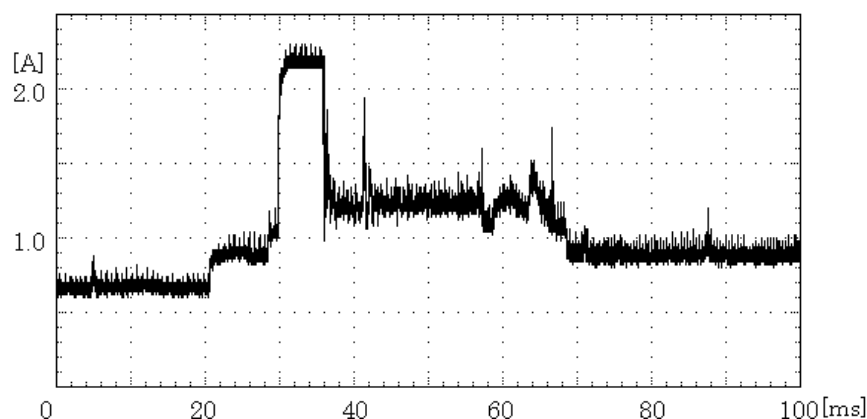

Figure 3.8 Current waveform (+5 VDC)

3.4 Cable Connections

3.4.1 Drive connectors

Figure 3.9 shows the connector and terminal locations.

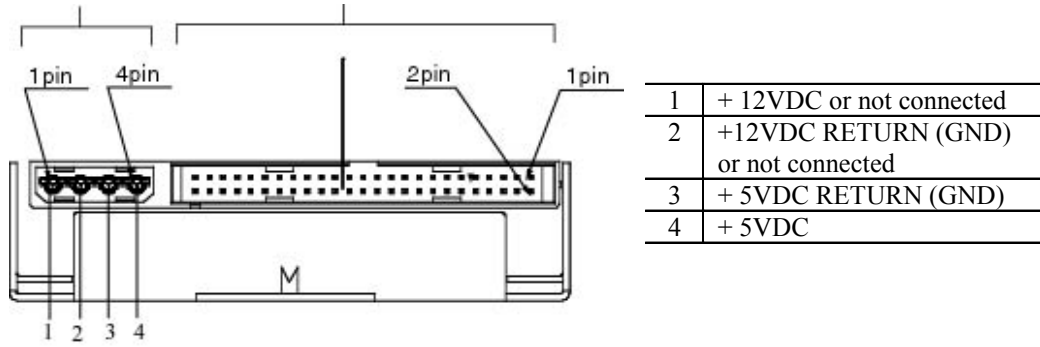

Figure 3.9 Connector and terminal locations

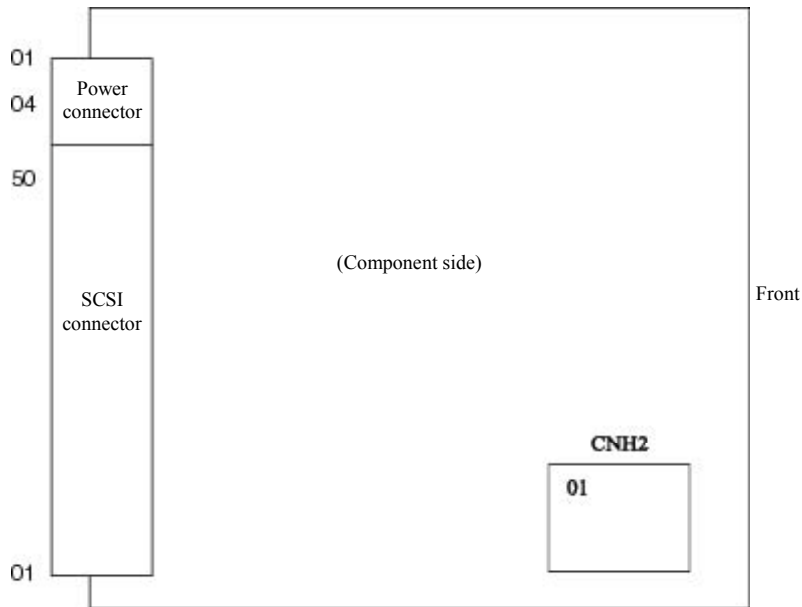

Figure 3.10 Location of setting terminal

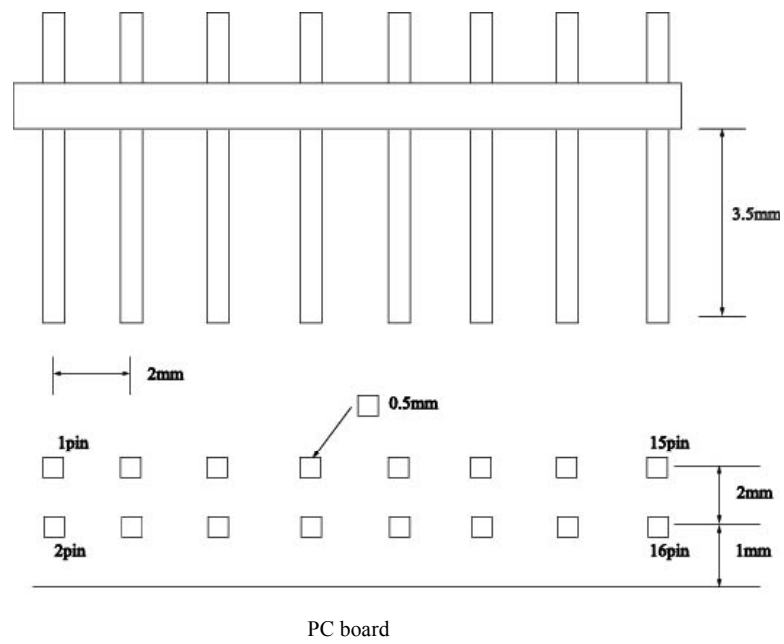

Figure 3.11 Shape of setting terminal

Table 3.3 Pin assignments

Pin No.	Pin name	Function
1	SCSI-ID (-)	-
2	SCSI-ID1	SCSI ID1 setting *1
3	SCSI-ID (-)	-
4	SCSI-ID2	SCSI ID2 setting *1
5	SCSI-ID (-)	-
6	SCSI-ID4	SCSI ID4 setting *1
7	GND	0V
8	TERM	SCSI Terminating resistor mode *2
9	GND	0V
10	Write Cache Mode	Write cache mode *2
11	GND	0V
12	Spindle Automatic Stop Mode	Automatic spindle stop mode *2
13	CTGIN	Cartridge insertion signal *2 *3
14	EJSW	Cartridge ejection signal *2 *4
15	LED (+)	Operating status LED signal *5
16	LED (-)	

*1 When pins 2, 4, and 6 are used, connect each pin to SCSI-ID (-).

*2 When pins 8, 10, 12, 13, and 14 are used, connect each pin to GND.

*3 This signal indicates that a cartridge is inserted in the device. This is a TTL level signal.

H: A cartridge is present.

L: No cartridge is present.

*4 This signal is used to instruct cartridge ejection from outside.

*5 The LED uses a forward current of 20 mA or less.

IMPORTANT

If voltage is applied to pin 14 from outside, the device may be damaged. When using this pin, be sure to connect it to GND.

3.4.2 Cable connector specifications

Table 3.4 Recommended components for connection

Category	Name	Model	Manufacturer
SCSI cable	Cable socket (closed-end type)	FCN-707B050-AU/B	Fujitsu Ltd.
	Cable socket (through-end type)	FCN-707B050-AU/O	Fujitsu Ltd.
	Signal cable	UL20184- LT25PX28AWG	Hitachi Cable, Ltd.
		455-248-50	SPECTRA- STRIP
Power supply cable	Housing for cable socket	1-480424-0	AMP
	Contact	170121-4	AMP
	Cable	AWG18	-
Setting terminal	Housing for cable socket	LPC-16F02	Honda-Tsushin
	Receptacle	LPC-F104N	Honda-Tsushin
	Cable	AWG28	-

IMPORTANT

A terminating resistor is mounted on the drive when the drive is shipped. A terminating resistor must be disconnected when the drive is not connected to an end of the SCSI cable.

3.4.3 Connection Modes

Figure 4.3 shows examples of connections between the host system and the optical disk drive. Up to eight devices including the host adapter, optical disk drive, and other SCSI equipment can be connected to the SCSI bus in arbitrary combinations. Install a terminating resistor on the SCSI devices connected to either end of the SCSI cable.

See Section 3.4 for the cable connection requirements and power cable connections.

- a. Connecting one optical disk drive

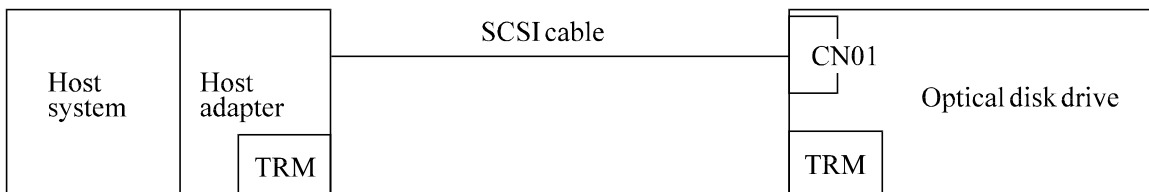

- b. Connecting more than one optical disk drive (single host)

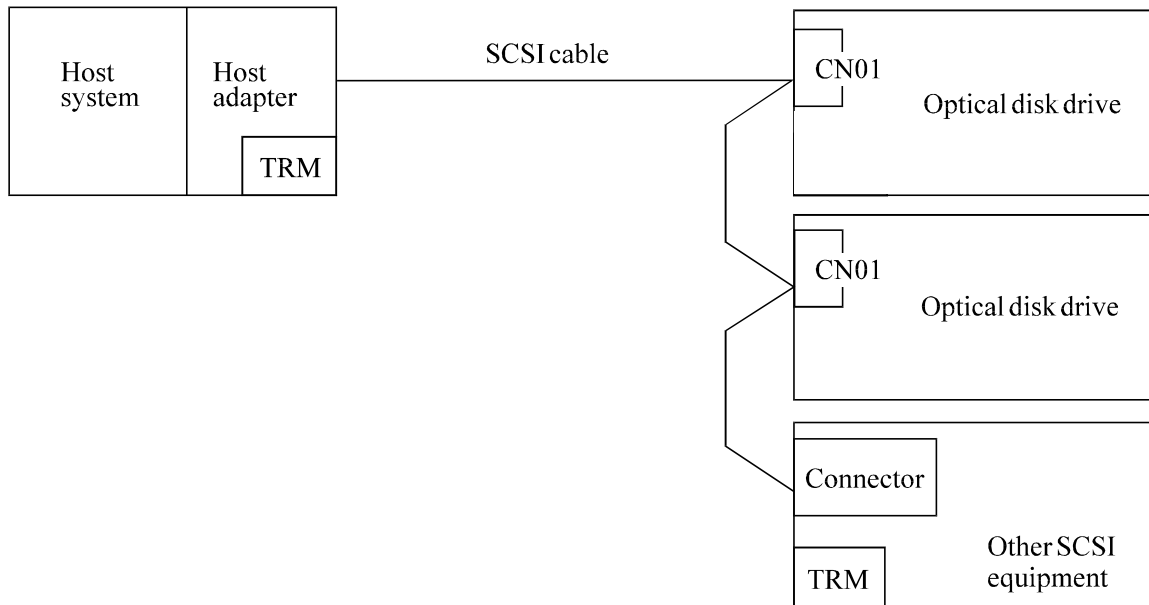
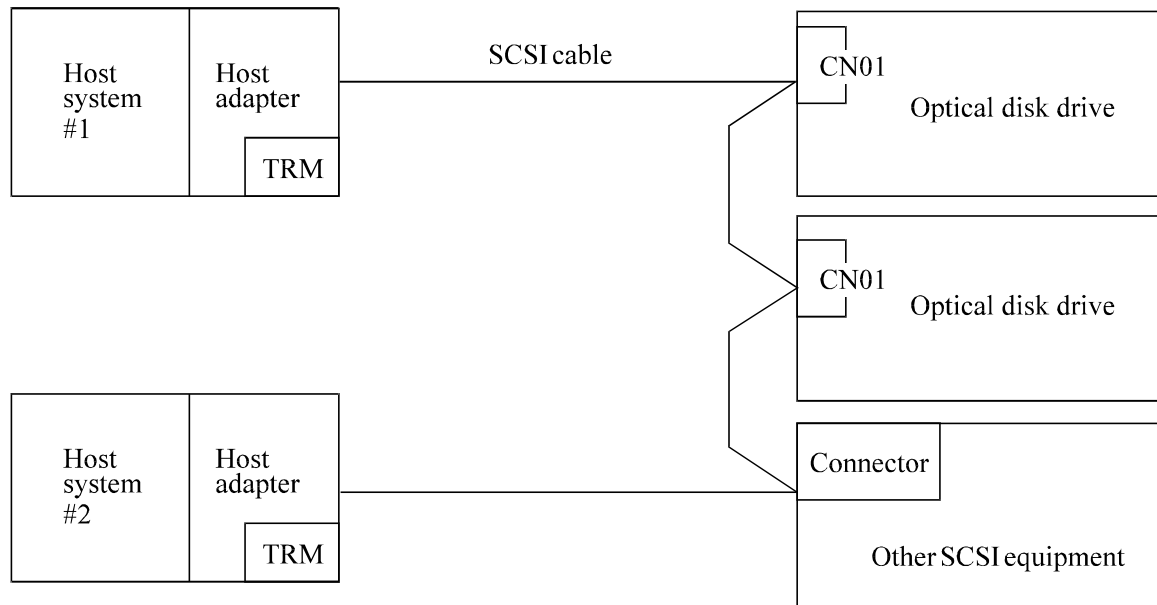

Figure 3.12 SCSI bus connection modes

c. Connecting more than one optical disk drive (multi-host)



TRM : SCSI terminating resistor

Connector : Interface connector

Figure 3.13 SCSI bus connection modes

Note: If more than one SCSI device is connected to the same SCSI bus, Fujitsu recommends using an external terminator.

3.5 Settings

3.5.1 Default jumper settings

Figure 3.14 shows the types of switches and their settings when the drive was shipped.

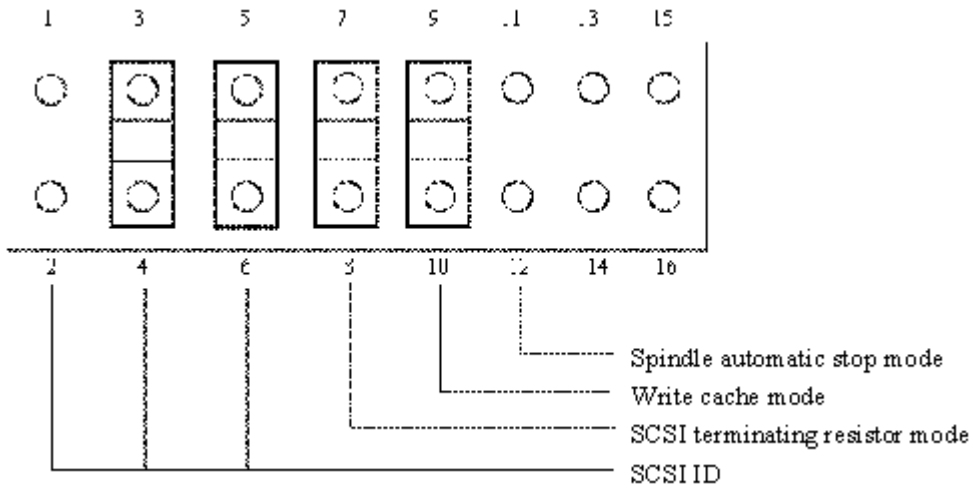

Figure 3.14 Setting terminal (CNH2)

3.5.2 Setting terminal

(1) SCSI ID

Table 3.5 shows the SCSI ID settings of the drive.

Table 3.5 SCSI ID setting (CNH2)

SCSI ID	Pin 5-6	Pin 3-4	Pin 1-2
0	Open	Open	Open
1	Open	Open	Short
2	Open	Short	Open
3	Open	Short	Short
4	Short	Open	Open
5	Short	Open	Short
6 *1	Short	Short	Open
7	Short	Short	Short

*1 Factory setting

IMPORTANT

- 1) Each SCSI device connected to the same SCSI bus must have a unique SCSI ID.
- 2) If contention occurs in the ARBITRATION phase, the priority of the SCSI use authority depends on SCSI IDs as follows:
7 > 6 > 5 > 4 > 3 > 2 > 1 > 0

(2) SCSI terminating resistor mode

Enabling or disabling the SCSI terminating resistor, module on the PCA can be set.

When the drive positions at other than the end of the SCSI bus, the SCSI terminating resistor should be disabled. Table 3.6 shows the SCSI terminating resistor mode setting.

Table 3.6 SCSI terminating resistor mode

SCSI terminating resistor mode	(7-8)
SCSI terminating resistor module on the PCA is enabled.	SHORT *1
SCSI terminating resistor module on the PCA is disabled.	OPEN

*1 Factory setting

(3) Write cache mode

The write cache mode can be set. The write cache mode can also be enabled or disabled by the MODE SELECT command.

Table 3.7 shows the settings of the write cache mode.

Table 3.7 Write cache mode setting

Write cache mode	(9-10)
Write cache is disabled at executing the WRITE/WRITE AND VERIFY command	OPEN
Write cache is enabled at executing the WRITE/WRITE AND VERIFY command.	SHORT *1

*1 Factory setting

IMPORTANT

When the write cache feature is enabled, a write error is reported at the completion status of next command. At a system so that the initiator retries the command, a retry process may be failed.

(4) Spindle automatic stop mode

The optical disk drive automatically enters standby mode if it receives no commands from the host for about 32 minutes (default value).

Table 3.8 Spindle motor automatic stop mode setting

Spindle motor automatic stop mode	(11-12)
The spindle motor automatically stops after a specified period of time.	SHORT
The spindle motor does not stop.	OPEN *1

*1 Factory setting

3.6 Notes on Drive Handling

(1) General notes

Note the following points to maintain drive performance and reliability:



Device damage:

- 1) Shock or vibration applied to the drive that exceeds the values defined in the standard damage the drive. Use care when unpacking.
- 2) Do not leave the drive in dirty or contaminated environments.
- 3) Since static discharge may destroy the CMOS devices in the drive, pay attention to the following points after unpacking:
 - Use an antistatic mat and wrist strap when handling the drive.
 - Hold the mounting frame when handling the drive. Do not touch the Printed circuit board except when setting the switches.
- 4) When handling the drive, hold both sides of the mounting frame. When touching other than both sides of the mounting frame, avoid putting force.
- 5) Do not forcibly push up the end of the header pin of the printed circuit board unit when handling or setting the drive.

(2) Unpacking

- Make sure that the UP label on the package is pointing upward and start unpacking on a level surface. Handle the drive on a soft surface such as a rubber mat, not on a hard surface such as a desk.
- Use care to avoid exerting excessive pressure on the unit when removing the cushions.
- Use care to avoid exerting excessive pressure on the printed circuit board surface and interface connectors when removing the drive from the antistatic bag.
- If the temperature difference between installation locations is 10 degrees or more, leave the drive in the new location for at least two hours before unpacking it.

(3) Installation

- Do not connect or disconnect the connectors or change the terminal settings when the power is on.
- Do not move the drive with the power on.
- Eject the optical disk cartridge, lock the carriage securing the head, turn off the power, then move the drive.

▲ CAUTION

Device damage: Be sure to turn on the power supply before inserting your cartridge for the first time. It releases the device from transport protection and enables you to insert the cartridge.

The device may be damaged if you insert the cartridge without releasing the protection. From the next time, you don't need to turn on the power supply beforehand.

Before moving the drive, remove the optical disk cartridge. If the drive is moved with the optical disk cartridge loaded in it, the head may move back and forth in the drive to damage the head or disk and reading the data may fail.

(4) Packing

- Before packing, remove the optical cartridge.
- Store the drive in an antistatic plastic bag with desiccant (silica gel).
- Use the same cushions and packaging supplied with the drive. If they are not available, ensure that adequate shock absorbent material is used. In this case, some method of protecting the printed circuit board surface and interface connectors must be used.
- Apply "UP" and "Handle With Care" labels to the outside of the package.

Figure 3.15 shows the single-unit packing style and the multiple-unit packing style. (The form and material of the cushion may be changed.)

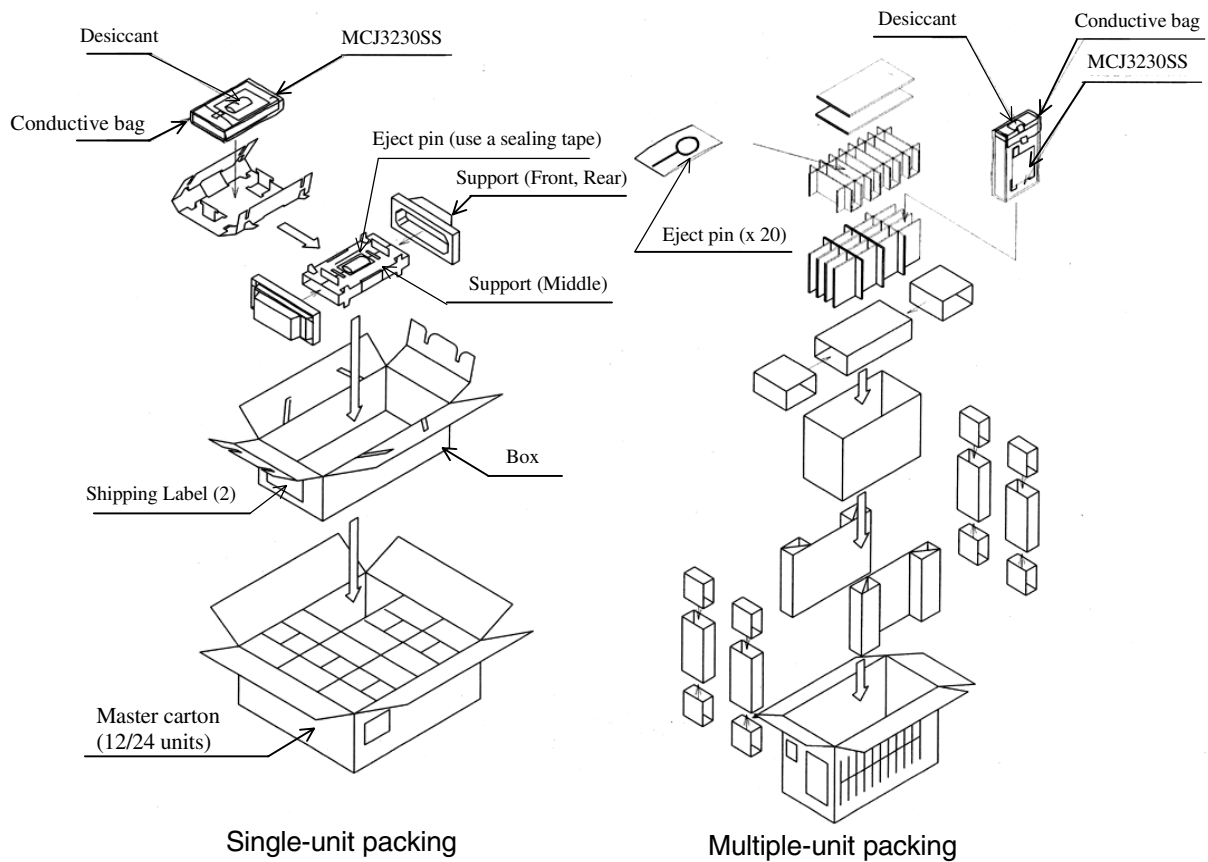

Figure 3.15 Packing style

(5) Transportation

- Transport the optical disk drive packed in principle, with the UP sign upward.
- After unpacking, minimize the transportation distance and use cushions to avoid shock and vibration. Transport the drive in one of the orientations described in Subsection 3.2.2 after unpacking. (The horizontal direction is recommended.)

(6) Storage

- Use moistureproof packaging when storing the drive.
- The storage environment must satisfy the requirements specified in Subsection 2.1.3 when the drive is not operating.
- To prevent condensation, avoid sharp changes in temperature.

3.7 Mounting

3.7.1 Checks before mounting the drive

Before mounting the optical disk drive in the system cabinet, check whether the jumper settings are set correctly.

3.7.2 Mounting procedure

How the drive is mounted depends on the system cabinet structure. Determine the mounting procedure in consideration of the requirements of each system. This section contains the general mounting procedure and check items.

See Section 3.2 for details on mounting drive.

- 1) Tighten four mounting screws to secure the drive in the system cabinet.
 - The drive has ten mounting holes (both sides: 3 × 2, bottom: 4). Secure the drive using the four mounting holes on both sides or the bottom.
 - Use mounting screws whose lengths are 3 mm or less from the external wall of the mounting frame of the drive when they are tightened. (See Figure 3.6)
 - When mounting with screws, the screw tightening torque should be 0.4 to 0.45Nm (4 to 4.6kgfcm).
 - Be careful not to damage the parts on the PCA when mounting the drive.
- 2) After securing the drive, make sure that the drive does not touch the chassis of the system cabinet. There must be at least 1.5 mm clearance between the drive and chassis. (See Figure 3.6)

3.8 Cable Connections

Use the following cables to connect the drive to the system. See Subsection 3.4 for details on the connector positions and cable requirements.

- Power supply cable
- SCSI interface cable
- DC ground cable (if required)

The general procedure for cable connection and notes on connecting cables are given below. Pay attention to the insertion direction of each cable connector.

CAUTION

- Make sure that the system power is off.
 - Do not connect or disconnect any cable when the power is on.
- 1) Connect the DC ground cable (only if required to decrease ground noise).
 - 2) Connect the power cables.
 - 3) Connect the SCSI interface cable.
 - 4) After each cable connector is connected, secure the cable so that the cable does not touch the drive or the parts on the PCA or obstruct the flow of cooling air in the system cabinet.

3.9 Operation Confirmation and Preparation for Use after Installation

3.9.1 Confirming initial operations

This section provides the operation check procedures after the power is turned on.

(1) Initial operation when the power is turned on

- When the power is turned on, the drive starts initial self-diagnosis. The LED on the front panel is on for 1 second during initial self-diagnosis.
- If an error is detected during initial self-diagnosis, the LED on the front panel blinks.
- In case of not inserted the cartridge, when the power is turned on, the eject motor automatically turns once.

(2) Checks if errors occur at initial self-diagnosis

- Make sure that the cables are connected correctly.
- Make sure that the supply voltage is correct. (Measure the voltage at the power supply connector of the optical drive.)
- Make sure that the settings of all terminals are correct.
- If the LED on the front panel blinks continuously, an error was detected during initial self-diagnosis. In this case, issue the REQUEST SENSE command from the initiator (host system) to obtain sense data for error analysis.

IMPORTANT

The BUSY LED is on while the optical disk drive is executing seek, write, or read operations. The BUSY LED is on momentarily, so it seems as if it blinked or is off.

The eject motor turns once when the power is turned on so that in case the spindle motor position deviates due to shocks received by the drive during transport the position is corrected to allow the cartridge to be inserted normally. If the cartridge fails to be inserted, remove the cartridge and turn on the drive power to turn the eject motor once and reinsert the cartridge.

3.9.2 Connection check

When initial operation check terminates normally after the power is turned on, check whether the drive is correctly connected by issuing command from the host system. Checking procedure depends on the host system configuration.

If processing terminates abnormally:

- 1) If sense data has been obtained by the REQUEST SENSE command, analyze the sense data. If the error is recoverable, retry the processing.
- 2) Check the following items for SCSI interface cable connection:
 - All connectors, including other devices, are connected correctly.
 - Make sure the correct cable is being used (whether it corresponds with the cable selection mode).
- 3) Make sure again that the jumper settings are correct.

3.10 Dismounting Drive

How to demount an optical disk drive (for setting terminal checking, setting change, or device replacement) depends on the system cabinet configuration. Determine the demounting procedure in consideration of the requirements of each system. This section describes the general demounting procedure and notes on demounting drives.



Device damage: Before demounting the optical disk drive, turn off the system power. Do not remove screws securing the cables and drive when the power is on.

- 1) Remove the power cable.
- 2) Remove the SCSI interface cable.
- 3) Remove the DC ground cable.
- 4) Remove the four screws securing the drive, then remove the drive from the system cabinet.
- 5) When storing or transporting the drive, put the drive into an antistatic bag. (See Section 3.6.)

This page is intentionally left blank.

CHAPTER 4 Host Interface

4.1 Interface Connector
4.2 Various Processes
4.3 SCSI Comands
4.4 SCSI Messages
4.5 Timing Rule

This chapter describes host interface specification.

4.1 Interface Connector

The nonshielded SCSI connector installed on the ODD is a 50-conductor connector consisting of two rows of 25 male pins with adjacent pins 2.54 mm (0.1 in.) apart. See Figure 4.1.

The nonshielded cable connector shall be a 50-conductor connector consisting of two rows of 25 female contacts with adjacent contacts 2.54 mm (0.1 in.) apart. The use of keyed connectors is recommended to prevent accidental misinsertion. See Figure 4.2.

Figure 4.3 shows the nonshielded connector pin assignments for SCSI.

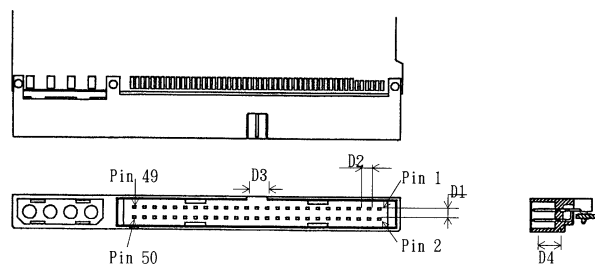

Symbol	mm	Remark
D1	2.54	-
D2	2.54	-
D3	5.08	-
D4	6.25	-

Note: The tolerance is ± 0.127 mm unless otherwise specified.

Figure 4.1 SCSi interface connector (ODD side)

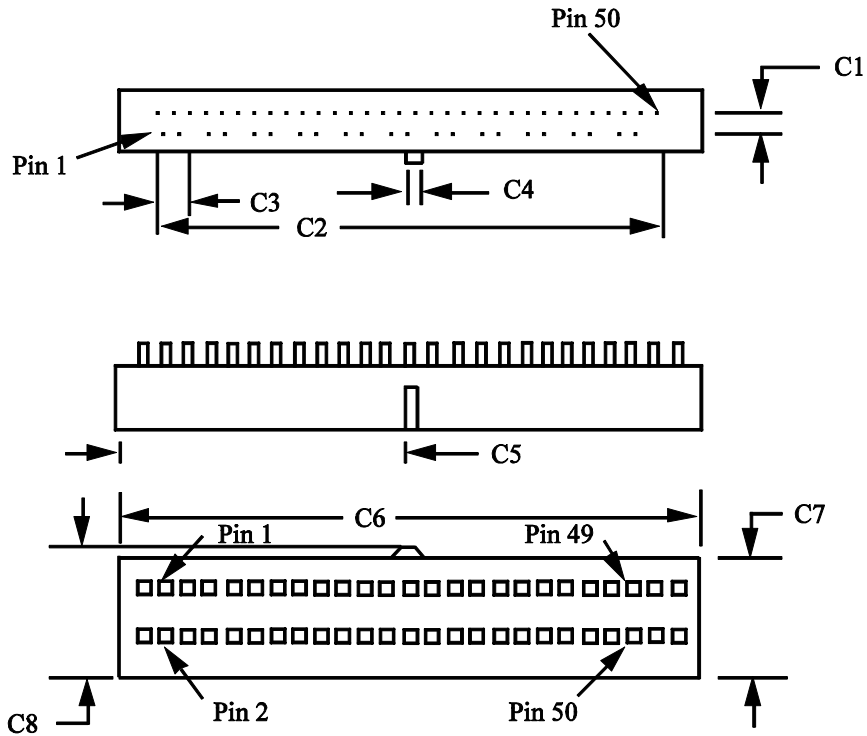

Symbol	mm	Remarks
C1	2.540	-
C2	60.960	-
C3	2.540	-
C4	3.302	-
C5	32.385	-
C6	68.072	-
C7	6.096	-
C8	7.620	Maximum value

Notes:

1. The tolerance is ± 0.127 mm unless otherwise specified.
2. A connector cover and strain relief are not shown in this figure.

Figure 4.2 SCSI interface connector (cable side)

Table 4.1 SCSI interface connector pin assignments (single-ended type)

01	G	-DB0	02
03	G	-DB1	04
05	G	-DB2	06
07	G	-DB3	08
09	G	-DB4	10
11	G	-DB5	12
13	G	-DB6	14
15	G	-DB7	16
17	G	-DBP	18
19	G	G	20
21	G	G	22
23	G	G	24
25	Open	TERMPWR*	26
27	G	G	28
29	G	G	30
31	G	-ATN	32
33	G	G	34
35	G	-BSY	36
37	G	-ACK	38
39	G	-RST	40
41	G	-MSG	42
43	G	-SEL	44
45	G	-C/D	46
47	G	-REQ	48
49	G	-I/O	50

* Terminating resistor power supply (jumper selectable: input only, both input and output, or open)

IMPORTANT

Note that shielded end processing is not performed with the connector on the main unit's optical disk unit for cables that use pin No.9 as the shielded ground.

4.2 Various Processes

4.2.1 Reset response

Three types of reset responses are available.

- Power-On Reset
 - The ODD performs initialization processes such as initial diagnosis and default setting. It also starts rotation of the media, if any is mounted.
- SCSI Reset
 - The ODD is reset when the RESET- signal is asserted. The ODD performs initialization of the interface controller, including such operations as writing the default values to the registers.
 - UNIT ATTENTION is generated.
- Bus Device Reset
 - The ODD is reset when a bus device reset message is received. The ODD performs initialization of the interface controller, including such operations as writing the default values to the registers.
 - UNIT ATTENTION is generated.

4.2.2 Defective sector management

The following standards for each type of media are used to manage sector mapping:

- ISO/IEC 10090 for 128-MB media
- ISO/IEC 13963 for 230-MB media
- ISO/IEC 15041 for 540/640-MB media
- Cherry Book for 1.3-GB media
- Cherry Book 2 for 2.3-GB media

In principle, the initiator need not manage defective sectors.

4.2.3 Automatic alternate sector assignment function

If a verify error is detected in the ID or data section when the WRITE (6/10), WRITE AND VERIFY, or ERASE command is executed, the ODD automatically assigns an alternate sector. Alternate sector information is entered in the secondary defect list (SDL) on the media.

No error is reported if automatic alternate sector assignment ends successfully.

4.2.4 Cache function

The ODD supports read cache and MO write cache.

The read cache consists of the read-ahead cache and the LRU cache that reads write data remaining in the data buffer.

The read-ahead cache enables data transfer at almost the same speed as the effective transfer speed during continuous read operation without causing delays resulting from rotation latency. If write and read operations are executed frequently on a same sector, the LRU cache enables the transfer of data without mechanical operation.

The MO write cache writes data in batch mode during continuous write operation, thus reducing the number of positioning operations, which is determined by the buffer size, and improving write throughput.

4.2.4.1 Data buffer

The ODD uses part of the buffer area as work memory for control firmware and the remaining area for a data buffer. The data buffer consists of multiple segments and contains multiple segments of write data.

4.2.4.2 Read cache

If the read cache function is enabled, the ODD enables the read-ahead cache and LRU cache. When a READ command is received while the read cache is enabled, the ODD reads the specified sector and continues pre-reading the following sectors. The ODD thus transfers data in the sectors specified by the command while pre-reading the sectors that follow.

When data in the sector specified by the host is pre-read data, the ODD transfers the data directly from the buffer without any mechanical operation.

The ODD stops pre-reading under any of the following conditions:

- Read error
- Data buffer full (The ODD may restart pre-reading when the buffer is no longer full.)
- Media ejection instruction given with the eject switch
- Power-off
- The system judges that performance will be improved by stopping the pre-reading and giving priority to other processing.

If the read cache is enabled, the buffer contains data transferred from the host with a write command. If a read command is issued for an applicable sector address, the ODD directly transfers data to the host from the data buffer rather than reading it from the media. If the cache is hit with a read command, the ODD places and keeps the data in the hit segment in the highest priority.

The following types of data are not subject to the read cache function:

- Data read before power-off
- Data stored before media is mounted

All buffer data is discarded when:

- The power is turned off.
- The media is ejected.
- A FORMAT UNIT command is received.
- The ODD is in standby mode.

Buffer data may be discarded when:

- A MODE SELECT command that changes the read conditions is received.

4.2.4.3 MO write cache

If the write cache is enabled, the ODD responds to the host with command completion when data transfer for a WRITE or WRITE AND VERIFY command (hereafter collectively called a write command) is completed.

The ODD writes data stored in the buffer to the media and proceeds to the next processing when:

- The eject switch is pressed.
- A SYNCHRONIZE CACHE command is received.

When data is contained in the buffer, and if any of the following conditions occurs, the data in the buffer may not be written to the media correctly:

- The power is turned off.
- The media is forcibly ejected (mechanical ejection).

4.2.5 Power management function

The ODD provides a power management function that minimizes power consumption. A timer is used to implement the function.

4.2.6 Power mode

The ODD supports the power modes listed below. If no media is mounted, the ODD uses a power mode equivalent to standby mode.

- Active mode
- Pre-idle mode
- Idle mode
- Standby mode

4.2.6.1 Active mode

In active mode, all circuits are enabled and the time for command processing is minimized.

4.2.6.2 Pre-idle mode

In pre-idle mode, the read and write circuits are in stopped state. The ODD can receive a command from the host, but since some circuits are stopped, the command requires an additional 20 ms to access the media.

The ODD automatically enters pre-idle mode if no command is issued within a specified time (0.5 s) in active mode. The ODD automatically enters active mode when it receives a media access command.

4.2.6.3 Idle mode

In idle mode, the servo, and read and write circuits are in stopped state. The ODD can receive a command from the host, but since some circuits are stopped, the command requires an additional 1 s (default) to access the media.

If no command is issued within a specified time (180 s) in active mode, the ODD automatically enters pre-idle mode, then enters idle mode. The ODD automatically enters active mode when it receives a media access command.

4.2.6.4 Standby mode

In standby mode, the spindle motor stays stopped. The ODD can receive a command from the host, but since the spindle motor is stopped, the command requires 5 s (default) for recovery before accessing the media.

If no command is issued within a specified time while the ODD is in active mode with the standby timer enabled, the ODD automatically enters standby mode. The ODD automatically enters active mode when it receives an access command.

4.2.6.5 Standby timer

The standby timer counts the elapsed time during which the host issues no commands.

The standby timer value is programmable with the Power Condition Page of the MODE SELECT command. The default standby timer value is 32 minutes (including the transition time to idle mode).

4.2.6.6 Power mode transition

The power mode transition is shown in Figure 4.3.

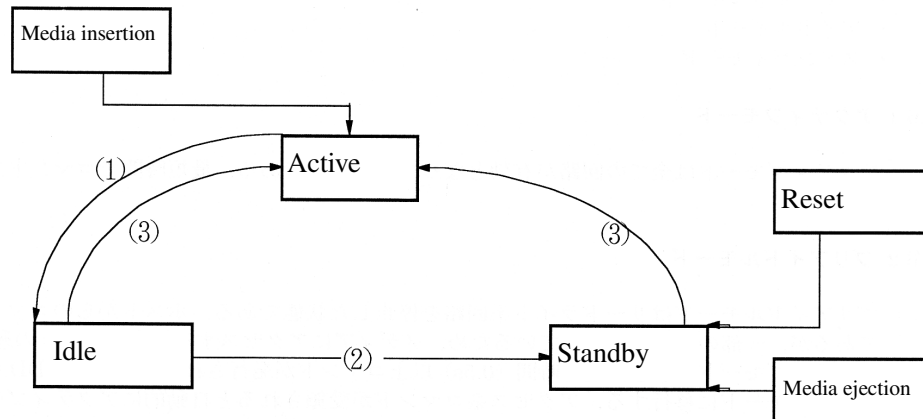

- (1) The ODD enters idle mode because it receives no command within a specified time.
- (2) The ODD enters standby mode based on the standby timer.
- (3) The ODD enters active mode because it receives a media access command.

Figure 4.3 Power mode

4.2.7 LED indications

The ODD notifies the operator of a serious error by turning on or blinking an LED. Table 4.2 lists the LED indications and the corresponding operations.

Table 4.2 LED indications

LED indication	Operation
Off	Waiting for a command
On	Command processing
	Seek operation
	Read/write processing (including cache processing)
	Formatting
	Power-on diagnosis
	Spinning up (including returning from standby mode)
	Spinning down (including shifting to standby mode)
Blinking (on for 0.1 s and off for 0.7 s repeatedly)	Starting firmware dedicated to downloading *1
Blinking (on for 0.1 s and off for 0.1 s repeatedly)	A power-on diagnosis error occurred.
Blinking (on for 0.4 s and off for 0.4 s repeatedly)	A thermal alarm occurred.
Blinking (on for 0.1 s and off for 0.3 s repeatedly)	An error occurred during writing to the write cache *2.

*1 ODD control firmware is stored in flash ROM and can be downloaded from the host with the WRITE BUFFER command. However, if a problem such as a power failure occurs during downloading, downloading is interrupted and the microcodes in the control firmware may be damaged. In such a case, to download the microcode data again, the ODD starts emergency download firmware that supports only the WRITE BUFFER command and other basic commands.

*2 The LED that is blinking because of a write cache write error stops blinking when the media is ejected.

4.3 SCSI Commands

Table 4.3 lists the SCSI commands supported by MCJ3230SS.

Table 4.3 SCSI commands

No.	CDB (HEX)	CDB length	Command name
1	2C	10	ERASE
2	04	6	FORMAT UNIT
3	12	6	INQUIRY
4	15	6	MODE SELECT
5	1A	6	MODE SENSE
6	1E	6	PREVENT/ALLOW MEDIUM REMOVAL
7	08	6	READ (6)
8	28	10	READ (10)
9	25	10	READ CAPACITY
10	37	10	READ DEFECT DATA
11	3E	10	READ LONG
12	1C	6	RECEIVE DIAGNOSTIC RESULTS
13	17	6	RELEASE
14	03	6	REQUEST SENSE
15	16	6	RESERVE
16	0B	6	SEEK (6)
17	2B	10	SEEK (10)
18	1D	6	SEND DIAGNOSTIC
19	1B	6	START/STOP UNIT
20	35	10	SYNCHRONIZE CACHE
21	00	6	TEST UNIT READY
22	2F	10	VERIFY
23	0A	6	WRITE (6)
24	2A	10	WRITE (10)
25	2E	10	WRITE AND VERIFY
26	3B	10	WRITE BUFFER
27	3F	10	WRITE LONG

4.3.1 TEST UNIT READY command

The TEST UNIT READY command checks whether a logical unit is ready to operate.

Table 4.4 TEST UNIT READY command

Bit Byte	7	6	5	4	3	2	1	0
0	Operation Code (00h)							
1	LUN			Reserved				
2-5	Reserved							

If the ODD power is on and the ODD is ready to operate, the command reports GOOD status. If the ODD is not ready or an error condition remains in the device even though the ODD is ready, the command reports CHECK CONDITION status. When this command is executed, the ODD resets the sense data.

4.3.2 INQUIRY

Table 4.5 INQUIRY command

Bit Byte	7	6	5	4	3	2	1	0
0	Operation Code (12h)							
1	LUN			Reserved				
2-3	Reserved							
4	Allocation Length							
5	Reserved							

The ODD returns CHECK CONDITION status only when it fails to return the INQUIRY data requested by the INQUIRY command.

When the ODD receives an INQUIRY command from INIT while it has a UNIT ATTENTION condition (before the ODD reports CHECK CONDITION status), the ODD executes the INQUIRY command but does not clear the UNIT ATTENTION condition.

The transfer byte length field at CDB byte 4 indicates the number of bytes of INQUIRY data that INIT can receive with this command. The ODD transfers as many bytes of data as specified by the transfer byte length or the INQUIRY data held by the ODD, whichever is smaller. If 0 is specified in the transfer byte length field, the command ends and no data is transferred.

Table 4.6 INQUIRY command response data

Bit Byte	7	6	5	4	3	2	1	0
0	Device classification code (000b)			Device Type				
	"7Fh" when a value other than 0 is specified for LUN							
1	RMB "Ih"	Reserved						
2	ISO Version "0h"		ECMA Version "0h"			ANSI Version "2h"		
3	Reserved				Response data format (2h)			
4	Additional length (2Bh)							
5-6	Reserved							
7	RelAdr '0'	WBus3 2 '0'	Wbus16 '0'	Sync '1'	Linked '0'	'0'	CmdQue '0'	SftRe '0'
8-15	Vendor Information "FUJITSU" (in ASCII) Left justified. The rightmost data area not used is padded with spaces. (20h)							
16-31	Product Information "MCJ3230SS" (in ASCII) Left justified. The rightmost data area not used is padded with spaces. (20h)							
32-35	Firmware Revision Level "0000"-"999z" (in ASCII)							
36	Firmware Local Revision 00h-FFh (in HEX)							
37	Boot Firmware Revision Level 00h-FFh (in HEX)							
38-39	Signature "MO" (in ASCII)							
40-47	Factory Information							

The Factory Information is the data that is provided for use at the factory. The data value may vary depending on the device. Therefore, INIT should not have an expected value. Normally, return 0.

4.3.3 READ CAPACITY command

Table 4.7 READ CAPACITY command

Bit Byte	7	6	5	4	3	2	1	0
0	Operation Code (25h)							
1	LUN			Reserved				
2-7	Reserved							
8	Reserved							PMI
9	Reserved							

The READ CAPACITY command transfers data related to the media capacity to INIT. Any value specified for the Partial Medium Indicator (PMI) bit is ignored.

The transfer data is listed in Table 4.8.

Table 4.8 READ CAPACITY data

Bit Byte	7	6	5	4	3	2	1	0
0-3	Last Logical Block Address							
4-7	Block Length in Bytes							

Last Logical Block Address indicates the address of the last block that can be accessed.

Block Length in Bytes indicates the number of bytes per block.

4.3.4 MODE SELECT command

Table 4.9 MODE SELECT command

Bit Byte	7	6	5	4	3	2	1	0
0	Operation Code (15h)							
1	LUN			PF	Reserved			SP
2-3	Reserved							
4	Parameter List Length							
5	Reserved							

The MODE SELECT command sets various device operating modes.

The Page Format (PF) bit must be 1. If the PF bit is 0, the command responds with Check Condition. If the Save Pages (SP) bit is 1, the ODD saves all parameter values transferred to flash ROM. Parameter List Length specifies the number of bytes in the mode parameter to be transferred. If the value is 0, the command ends normally without transferring any data. If the transferred mode

parameters are incomplete, the command responds with Check Condition without any processing.

Table 4.10 lists the pages supported.

Table 4.10 Mode page codes

Definition	Page Code
Read-Write Error Recovery Page	01h
Flexible Disk Page	05h
Caching Page	08h
Power Condition Page	1Ah
Verify Control Page	3Eh

Table 4.11 is a mode parameter list.

Table 4.11 Mode parameter list

Bit Byte	7	6	5	4	3	2	1	0
0-4	Mode Parameter Header							
0-7	Block Descriptor							
0-n	Mode Page (s)							

The mode parameter list consists of Mode Parameter Header, Block Descriptor, and Mode Page.

Table 4.12 shows the format of the Mode Parameter Header.

Table 4.12 Mode parameter header

Bit Byte	7	6	5	4	3	2	1	0
0	Mode Data Length							
1	Medium Type Code							
2	WP	Reserved						
3	Block descriptor Length							

Values specified for Mode Data Length, Medium Type Code, and WP are ignored. Block Descriptor Length must be 0 or 8.

Table 4.13 shows the format of the Block Descriptor.

The value specified for Block Descriptor is ignored.

Table 4.13 Block descriptor

Bit Byte	7	6	5	4	3	2	1	0
0	Density Code (00h)							
1-3	Number of Blocks							
4	Reserved							
5-7	Block Length							

Table 4.14 shows the format of the Mode Page field.

Table 4.14 Mode page

Bit Byte	7	6	5	4	3	2	1	0
0	PS	0	Page Code					
1	Page Length (n-1)							
2-n	Mode Parameters							

(1) Read/write error recovery page

Table 4.15 Read/write error recovery page

Bit Byte	7	6	5	4	3	2	1	0
0	PS (1)	0	Page Code (01h)					
1	Page Length (0Ah)							
2	AWRE	Reserved	Reserved	RC	Reserved	PER	Reserved	DCR
3	Read Retry Count							
4-7	Reserved							
8	Write Retry Count							
9-11	00h							

If the Automatic Write Reallocation Enabled (AWRE) bit is 0, no automatic alternate block assignment is made by the WRITE (6), WRITE (10), or WRITE AND VERIFY command. If the AWRE bit is 1, an automatic alternate block assignment function is enabled.

If the Read Continuous (RC) bit is 0, an error is reported if an uncorrectable data error is detected in the READ (6) or READ (10) command. If the RC bit is 1, the command transfers the erroneous data and ends normally even if an uncorrectable data error is detected.

If the Post Error (PER) bit is 0, the command reports GOOD status if an error is corrected with the error recovery process. If the PER bit is 1, the command reports CHECK CONDITION status if an error is corrected with the error recovery process. The Sense Key is then set to RECOVERED ERROR.

RECOVERED ERROR is reported when:

- Seven or eight error bytes occurring per interleaving are corrected by the ECC feature during a read operation.
- A defective sector is detected and replaced with an alternate sector during a write operation.
- An error occurs in one of four sets of media data during media management information (DMA) write operation caused by the FORMAT UNIT command (MEDIUM ERROR is set if an error occurs in two, three, or four sets of four sets).

If the Disable Correction (DCR) bit is 0, the command corrects any correctable errors detected in a read command. If the DCR bit is 1, the command does not correct any correctable errors that are detected.

A value of 3 or fewer cannot be specified for Read Retry Count. If 3 or fewer is specified, the command processing assumes that 4 is specified and reports Recovered Error.

The value of Write Retry Count must be 3. If a value other than 3 is specified, the command processing assumes that 3 is specified and reports Recovered Error.

To ensure media compatibility, the read-write error recovery page must contain the default values, except when the settings are used for a diagnosis.

The values in the Read-write error recovery page can be saved.

Table 4.16 Variable values in the read-write error recovery page

Bit Byte	7	6	5	4	3	2	1	0
2	1	0	0	1	0	1	0	1
3	FFh							
4-7	00h							
8	FFh							
9-11	00h							

Table 4.17 Default values in the read-write error recovery page

Bit Byte	7	6	5	4	3	2	1	0
2	1	0	0	0	0	0	0	0
3	3Fh							
4-7	00h							
8	03h							
9-11	00h							

(2) Flexible disk page

Table 4.18 Flexible disk page

Bit Byte	7	6	5	4	3	2	1	0
0	0	0	Page Code (05h)					
1	Page Length (1Eh)							
2-3	Transfer Rate							
4	Number of Heads							
5	Sectors per Track							
6-7	Data Bytes per Sector							
8-9	Number of Cylinders							
10-19	Reserved							
20	Motor off Delay							
21-27	Reserved							
28-29	Medium Rotation Rate							
30-31	Reserved							

The Flexible disk page is only supported for compatibility of device drivers. Device drivers should not use this page to guarantee the logical compatibility of media.

The unit of Transfer Rate is kbps.

Number of Heads, Sectors per Track, and Number of Cylinders define logical values, and do not indicate physical values. If a device driver or application uses these values, logical compatibility of media is not guaranteed.

Data Bytes per Sector defines block length (200h or 800h).

Motor off Delay defines the duration after which the motor is instructed to stop. FFh indicates that the motor is not instructed to stop.

Medium Rotation Rate defines revolutions per minute (rpm).

Table 4.19 Variable values in the flexible disk page

Bit Byte	7	6	5	4	3	2	1	0
2-3	0000h							
4	00h							
5	00h							
6-7	00h							
8-9	0000h							
10-19	0000h							
20	00h							
21-27	00h							
28-29	0000h							
30-31	00h							

Table 4.20 Default values in the flexible disk page

Bit Byte	7	6	5	4	3	2	1	0
2-3	3E80h							
4	40h							
5	20h							
6-7	640 MB, 1.3 GB, or 2.3 GB media: 800h Other media or Not Ready: 200h							
8-9	Number of media LBAs: 40h x 20h (If Not Ready, the value of the maximum capacity media among supported 512-sector media)							
10-19	00h							
20	FFh							
21-27	00h							
28-29	1194h							
30-31	00h							

(3) Caching page

Table 4.21 Caching page

Bit Byte	7	6	5	4	3	2	1	0
0	PS (1)	0	Page Code (08h)					
1	Page Length (12h)							
2	Reserved					WCE	Reserved	RCD
3-19	Reserved							

If the Write Cache Enable (WCE) bit is 0, the write cache function for the WRITE (6), WRITE (10), and WRITE AND VERIFY commands is disabled. If the bit is 1, the write cache function is enabled.

If the Read Cache Disable (RCD) bit is 0, the read-ahead cache function for the READ (6) and READ (10) commands is enabled. If the bit is 1, the read-ahead cache function is disabled.

The values in the Caching page can be saved.

Table 4.22 Variable values in the Caching Page

Bit Byte	7	6	5	4	3	2	1	0
2	0	0	0	0	0	1	0	1
3-19	00h							

Table 4.23 Default values in the Caching Page

Bit Byte	7	6	5	4	3	2	1	0
2	0	0	0	0	0	1	0	0
3-19	00h							

(4) Power condition page

Table 4.24 Power condition page

Bit Byte	7	6	5	4	3	2	1	0
0	PS (1)	0	Page Code (1Ah)					
1	Page Length (0Ah)							
2	Reserved							
3	Reserved						Idle	Standby
4-7	Idle Condition Timer (in units of 100 ms)							
8-11	Standby Condition Timer (in units of 100 ms)							

Any values specified for the Idle bit or Idle Condition Timer bits are ignored. The ODD always uses the default timer values.

If the Standby bit is 1, Standby Condition Timer defines the time elapsed before the ODD enters standby mode after it enters idle mode.

Specify the values for Idle Condition Timer and Standby Condition Timer in units of 100 ms.

If the value specified for Standby Condition Timer is not a multiple of 600 (258h), the ODD automatically rounds the value down to the next multiple of 60 s.

The values in the Power condition page can be saved.

Table 4.25 Variable values in the Power condition page

Bit Byte	7	6	5	4	3	2	1	0
2	0							
3	0						0	1
4-7	0							
8-11	ffffffh							

Table 4.26 Default values in the Power condition page

Bit Byte	7	6	5	4	3	2	1	0
2	0							
3	0						1	1
4-7	00000708h							
8-11	000043F8h							

(5) Verify control page

Table 4.27 Verify control page

Bit Byte	7	6	5	4	3	2	1	0
0	PS (1)	0	Page Code (3Eh)					
1	Page Length (06h)							
2	AV	SM	Reserved				VM	
3	Reserved			DevType				
4-7	Reserved							

The Verify control page is unique to each vendor.

If the Audio Visual Mode (AV) bit is 0, normal cache mode is used. If the bit is 1, AV data support mode is used.

If the Streaming Mode (SM) bit is 0, a test write operation may interrupt a read or write operation. If the bit is 1, the test write operation is suppressed during continuous read or write operation. Fujitsu recommends setting the SM bit to 0.

Verify Mode (VM) specifies a verify operation for the WRITE command.

Table 4.28 Verify mode

VM	Description
0	Always enable verify operation.
1	Always disable verify operation.
2	Conditionally enable verify operation (verify skip mode).
3	Reserved

DevType specifies the device type that is returned in response to the Inquiry command. To validate the specified value, save it, then turn the power off and on again.

The values in the Verify control page can be saved.

Table 4.29 Variable values in the Verify control page

Bit Byte	7	6	5	4	3	2	1	0
2	1	1	0			11b		
3	0			1Fh				
4-7	0							

Table 4.30 Default values in the Verify control page

Bit Byte	7	6	5	4	3	2	1	0
2	1	0	0			00b		
3	0			0h				
4-7	0							

4.3.5 MODE SENSE command

Table 4.31 MODE SENSE command

Bit Byte	7	6	5	4	3	2	1	0
0	Operation Code (1Ah)							
1	Reserved				DBD	Reserved		
2	PC		Page Code					
3	Reserved							
4	Allocation Length							
5	Reserved							

The MODE SENSE command transfers a mode parameter list to INIT.

If Disable Block Descriptor (DBD) is 1, the command does not return a block descriptor. If DBD is 0, the command returns a block descriptor.

Allocation Length specifies the number of bytes of the mode parameter to be transferred. If Allocation Length is 0, the command ends normally without transferring any data.

Page Control (PC) specifies the type of page to be sent.

Table 4.32 Page control field

Bit 7	Bit 6	Parameter type
0	0	Current value
0	1	Variable value
1	0	Default value
1	1	Saved value

Page Code specifies a mode page to be transferred. If Page Code is 3Fh, all mode pages are transferred. Table 4.10, "Mode page codes" lists the mode pages that are supported.

Mode pages are transferred in ascending order of page code.

If 0 is specified for both Page Code and Page Control, the command transfers Mode Parameter Header and Block Descriptor (only if the DBD bit is 0).

Table 4.33 is a list of mode parameters.

Table 4.33 Mode parameters

Bit Byte	7	6	5	4	3	2	1	0
0-4	Mode Parameter Header							
0-7	Block Descriptor							
0-n	Mode Page (s)							

The mode parameter list consists of Mode Parameter Header, Block Descriptor, and Mode Page.

Table 4.34 shows the format of the Mode Parameter Header field.

Table 4.34 Mode Parameter Header

Bit Byte	7	6	5	4	3	2	1	0
0	Mode Data Length							
1	Medium Type Code							
2	WP	Reserved						
3	Block Descriptor Length							

Medium Type Code returns the following values:

- 03h for normal MO media
- 07h for overwrite MO media
- 03h for other media or Not Ready state

The Write Protect (WP) bit indicates the state of the write protect key on the cartridge. If the WP bit is 1, the cartridge is write-protected.

Mode Data Length indicates the length (bytes) of mode data to be transferred.

Block Descriptor Length indicates the length (bytes) of the block descriptor to be transferred.

Table 4.35 shows the format of the Block Descriptor field.

Table 4.35 Block Descriptor

Bit Byte	7	6	5	4	3	2	1	0
0	Density Code (00h)							
1-3	Number of Blocks							
4	Reserved							
5-7	Block Length							

Each field value of Block Descriptor is valid only when accessible media is inserted. If accessible media is not inserted, 0 is returned.

Table 4.36 shows the format of the Mode Page field.

Table 4.36 Mode Page

Bit Byte	7	6	5	4	3	2	1	0
0	PS	0	Page Code					
1	Page Length (n-1)							
2-n	Mode Parameters							

If PS is 1, page data can be saved to flash ROM.

4.3.6 START/STOP UNIT command

Table 4.37 START/STOP UNIT command

Bit Byte	7	6	5	4	3	2	1	0
0	Operation Code (1Bh)							
1	LUN			Reserved				IMMED
2-3	Reserved							
4	Reserved					LoEj		Start
5	Reserved							

The START/STOP UNIT command ejects media or starts or stops rotating the disk.

If the Immediate (IMMED) bit is 1, command completion is reported before processing is completed.

Table 4.38 lists the types of processing performed depending on the values specified for LoEj and Start.

Table 4.38 Start, stop, and eject processing

LoEj	Start	Processing
0	0	Stops disk rotation.
0	1	Starts disk rotation and checks the type of media format.
1	0	Ejects media, if possible.
1	1	Ends with an error (ILLEGAL REQUEST).

4.3.7 RESERVE command

Table 4.39 RESERVE command

Bit Byte	7	6	5	4	3	2	1	0
0	Operation Code (16h)							
1	LUN			Reserved				
2-5	Reserved							

As with the RELEASE command (explained next), the RESERVE command controls exclusive access to the logical unit (ODD) in a multi-initiator environment. The ODD is reserved for another SCSI device by the INIT that issues this command.

Any values specified for CDB bytes 1 to 5 are ignored. However, INIT should specify 00h for these bytes.

The RESERVE command reserves the entire ODD (logical unit) for a specific SCSI device. The ODD reserved by this command remains reserved until one of the following conditions is met:

- The RELEASE command is issued by the INIT that issued the RESERVE command.
- A BUS DEVICE RESET message is issued by an INIT.
- A RESET condition occurs.
- The ODD power is turned off and on again.

While an ODD is reserved for a SCSI device, an INIT having no "reservation authority" for the ODD might issue this command. If so, the command ends with RESERVATION CONFLICT status.

After ODD reservation is established, any commands, other than the INQUIRY, REQUEST SENSE, and RELEASE commands, issued by an INIT other than the SCSI device that reserved the ODD are rejected. The RESERVATION CONFLICT status is reported to the INIT that issued the command. The INQUIRY and REQUEST SENSE commands are executed normally even while the ODD is reserved for another SCSI device. The RELEASE command ends with GOOD status, but any RELEASE command issued by a SCSI device having no reservation authority for the applicable ODD is ignored.

4.3.8 RELEASE command

Table 4.40 RELEASE command

Bit Byte	7	6	5	4	3	2	1	0
0	Operation Code (17h)							
1	LUN			Reserved				
2-5	Reserved							

The RELEASE command releases the ODD reserved by the INIT that issued this command. When any of the following conditions is met, the command ends with GOOD status but it does not affect the reserved status of the ODD:

- The reserved status created by the INIT that has issued this command is not in the ODD.
- The reserved status of the type of release target specified by CDB of this command is not in the ODD.
- The specified ODD may be reserved for another SCSI device.

Any values specified for CDB bytes 1 to 5 are ignored. However, INIT should specify 00h for these bytes.

In terms of the entire ODD (logical unit), the RELEASE command releases any reserved status for which the INIT that issued the command has reservation authority.

4.3.9 REQUEST SENSE command

Table 4.41 REQUEST SENSE command

Bit Byte	7	6	5	4	3	2	1	0
0	Operation Code (03h)							
1	LUN			Reserved				
2-3	Reserved							
4	Allocation Length							
5	Reserved							

The REQUEST SENSE command transfers sense data to the INIT. Sense data indicates detailed error information related to the command for which an error was previously reported. If no error was previously reported for a command, Sense Key indicates NO SENSE.

When issuing the REQUEST SENSE command to detect the device status, first issue the TEST UNIT READY command, then issue the REQUEST SENSE command.

Allocation Length specifies the length of sense data to be transferred, in bytes. If 0 is specified, the command does not transfer any data and ends normally.

Table 4.42 shows the format of the Sense Data field.

Table 4.42 Request Sense Data

Bit Byte	7	6	5	4	3	2	1	0
0	Valid	Error Code (70h or 71h)						
1	Reserved (00h)							
2	Reserved (0h)				Sense Key			
3-6	Information							
7	Additional Sense Length (18h)							
8-11	Command-Specific Information							
12	Additional Sense Code							
13	Additional Sense Code Qualifier							
14	Reserved (00h)							
15-17	Sense-key specific							
18-31	Additional Sense Bytes							

If the Valid bit is 1, the Information field is valid.

Error Code indicates the sense data format and type. See Table 4.43.

Table 4.43 Error Code

Error Code	Report timing
70h (current error)	Reported for an error occurring during normal operation
71h (deferred error)	Reported if a cached write operation causes an error while the write cache is enabled. If this sense data is reported, the command that reports the Check Condition status is not executed.

Sense Key summarizes the error. The meanings of the Sense Key values are listed in Table 4.44.

Table 4.44 Sense Key

Sense Key	Mnemonic	Meaning
0h	NO SENSE	There is no sense key to be reported. NO SENSE is set when a command ends normally.
1h	RECOVERED ERROR	Recovery processing ended successfully or the commands ended normally using the internal default values even though invalid data was detected in command parameters. (This sense data is not reported if the PER bit is 0.)
2h	NOT READY	No access commands can be used.
3h	MEDIUM ERROR	An unrecoverable error due to media failure was detected.
4h	HARDWARE ERROR	An unrecoverable error due to hardware failure was detected.
5h	ILLEGAL REQUEST	A command packet or command parameter contains invalid data; media data remains unchanged.
6h	UNIT ATTENTION	Reset state, power-on, or media replacement was caused.
7h	DATA PROTECT	Media is write-protected with the write-protect switch or with software.
8h	BLANK CHECK	A blank sector was detected. This sense key is reserved.
9h- Ah	Reserved	Reserved
Bh	ABORTED COMMAND	Processing of the command was interrupted.
Ch- Fh	Reserved	Reserved

Information indicates the LBA of the block in which an error occurred. If errors occur in multiple blocks, Information indicates the LBA of the block in which the first error occurred.

Command-Specific Information indicates the logical track address of the block indicated by Information. The format of the logical track address is shown in Table 4.45.

Table 4.45 Logical track address format

Byte	Description
8-9	Logical track address
10	00h
11	Logical sector address

Additional Sense Code (ASC) and Additional Sense Code Qualifier (ASCQ) indicate detailed error information. Table 4.46 lists the ASC and ASCQ definitions.

Table 4.46 ASC and ASCQ definitions

Sense Key	ASC	ASCQ	Error description
2	04	00	LOGICAL UNIT NOT READY, CAUSE NOT REPORTABLE
2	04	04	LOGICAL UNIT NOT READY, FORMAT IN PROGRESS
3	09	00	TRACK FOLLOWING ERROR
4	08	03	LOGICAL UNIT COMMUNICATION CRC ERROR
3	09	01	TRACKING SREVO ERROR
3	0C	00	WRITE ERROR
3	0C	02	WRITE ERROR/AUTO REALLOCATION FAILED
3	10	00	ID CRC ERROR
3	11	00	UNRECOVERED READ ERROR
3	15	02	POSITIONING ERROR DETECTED BY READ OF MEDIUM
1	17	06	RECOVERED DATA WITHOUT ECC/DATA AUTO REALLOCATED
1	18	00	RECOVERED DATA WITH ERROR CORRECTION & RETRIES APPLIED
1	19	00	DEFECT LIST ERROR
3	19	01	DEFECT LIST NOT AVAILABLE
3	19	02	DEFECT LIST ERROR IN PRIMARY LIST
3	19	03	DEFECT LIST ERROR IN SECONDARY LIST
1	1C	00	DEFECT LIST NOT FOUND
5	20	00	INVALID COMMAND OPERATION CODE
5	21	00	LOGICAL BLOCK ADDRESS OUT RANGE
5	24	00	INVALID FIELD IN COMMAND PACKET
5	25	00	LOGICAL UNIT NOT SUPPORTED
5	26	00	INVALID FIELD IN PARAMETER LIST
7	27	00	WRITE PROTECTED
6	28	00	NOT READY TO READY TRANSITION, MEDIUM MAY HAVE CHANGED
6	29	00	POWER ON, RESET DEVICE RESET OCCURRED
3	30	00	INCOMPATIBLE MEDIUM INSTALLED
3	30	01	CANNOT READ MEDIUM/UNKNOWN FORMAT
3	31	00	MEDIUM FORMAT CORRUPTED
3	31	01	FORMAT COMMAND FAILED
3	32	00	NO DEFECT SPARE LOCATION AVAILABLE
3	32	01	DEFECT LIST UPDATE FAILURE
1	37	00	ROUNDED PARAMETER
2	3A	00	MEDIUM NOT PRESENT
4	40	NN	DIAGNOSTIC FAILURE ON COMPONENT NN
4	44	00	INTERNAL TARGET FAILURE
4	4A	00	COMMAND PHASE ERROR
4	4B	00	DATA PHASE ERROR

Sense Key	ASC	ASCQ	Error description
B	4E	00	OVERLAPPED COMMAND ATTEMPTED
4	53	00	MEDIA LOAD OR EJECT FAILED
5	53	02	MEDIUM REMOVAL PREVENTED
4	83	00	THERMAL ERROR

Table 4.47 shows the format of the Sense-Key Specific field. Progress Indication is valid only when Sense Key is NOT READY and the SKSV bit is 1. Otherwise, the field is set to 00h. This field is defined for the FORMAT UNIT command with the Immed bit set to 1.

Table 4.47 Format progress indication bytes

Bit Byte	7	6	5	4	3	2	1	0
15	SKSV	Reserved						
16-17	Progress Indication							

Progress Indication indicates the rate of formatting completion when the denominator is 65536 (10000h).

IMPORTANT

INIT should not use the REQUEST SENSE command alone to check the ODD status. Because the REQUEST SENSE command is used by INIT to retrieve sense data that is held by the ODD on various occasions, the contents of the sense data depend on the results of the command executed previously.

Example: Response when the ODD is in Not Ready state
 When INIT issues the TEST UNIT READY command, the ODD ends processing with Check Condition Status and responds to the REQUEST SENSE command with Not Ready Sense Data. When the INIT issues the INQUIRY command, the ODD responds with Inquiry Data and ends processing with Good status. If INIT continuously issues the REQUEST SENSE command, the ODD responds with No Sense because the previous command has ended normally and the ODD holds no sense data.

4.3.10 PREVENT/ALLOW MEDIUM REMOVAL command

Table 4.48 PREVENT/ALLOW MEDIUM REMOVAL command

Bit Byte	7	6	5	4	3	2	1	0
0	Operation Code (1Eh)							
1	LUN			Reserved				
2-3	Reserved							
4	Reserved							Prevent
5	Reserved							

The PREVENT/ALLOW MEDIUM REMOVAL command enables or disables media ejection from the device.

If the Prevent bit is 0, ejection is enabled. If the Prevent bit is 1, ejection is disabled.

At power-on, media ejection is enabled by default.

When unwritten data remains in the write cache, media ejection is enabled after the data is written to the media.

SCSI Reset or Bus Device Reset releases the disabled state and enables ejection.

Table 4.49 Responses to Prevent, Allow, and Eject

Operation	Status at operation	If no media is loaded	If media is loaded
Prevent = 0	Enabled	No error	No error
	Disabled	No error	No error
Prevent = 1	Enabled	No error	No error. Media ejection is disabled.
	Disabled	No error	No error
Eject (Ejection by START/STOP UNIT command)	Enabled	No error	No error. The cartridge is ejected.
	Disabled	Error: SENSE KEY 5 ASC/ASCQ 5302	Error: SENSE KEY 5 ASC/ASCQ 5302
Eject (Ejection by the eject switch)	Enabled	No status change	The cartridge is ejected.
	Disabled	No status change	No status change; media ejection remains disabled.

4.3.11 READ (6) command

The READ (6) command reads the specified number of blocks of data from the specified logical block address and transfers it to INIT.

Table 4.50 CDB of READ (6) command

Bit Byte	7	6	5	4	3	2	1	0
0	Operation Code (08h)							
1	LUN			(MSB)				
2	Logical Block Address							
3								
4	Transfer Length							
5	Reserved							

Logical Block Address specifies the logical block address at which the command should start reading data. Transfer Length specifies the number of consecutive logical blocks of data to be transferred. If Transfer Length is 00h, the command assumes that 100h is specified for Transfer Length. If Transfer Length is other than 00h, the command assumes it to be the number of logical blocks to transfer, and returns the latest data written in the logical blocks specified by the address.

4.3.12 READ (10) command

Table 4.51 READ (10) command

Bit Byte	7	6	5	4	3	2	1	0
0	Operation Code (28h)							
1	LUN			Reserved				
2-5	Logical Block Address							
6	Reserved							
7-8	Transfer Length							
9	Reserved							

The READ (10) command reads the specified number of blocks of data from the specified logical block address and transfers it.

Logical Block Address specifies the logical block address at which the command should start reading data. Transfer Length specifies the number of logical blocks of data to be read and transferred. If Transfer Length is 0, the command transfers no data. It simply ends normally without reading any data.

4.3.13 VERIFY command

Table 4.52 VERIFY command

Bit Byte	7	6	5	4	3	2	1	0
0	Operation Code (2Fh)							
1	LUN			Reserved			ByteChk	Reserved
2-5	Logical Block Address							
6	Reserved							
7-8	Verification Length							
9	Reserved							

The VERIFY command verifies the specified number of blocks beginning at the specified logical block address. Logical Block Address specifies the logical block address at which the command should start verifying data. Verification Length specifies the number of blocks to be verified. If Verification Length is 0, the command ends normally without verifying any data.

The ByteChk bit controls data compare processing. However, since the ODD does not support ByteChk, this bit must be set to 0. If 1 is specified, the command ends with Check Condition.

4.3.14 WRITE (6) command

The WRITE (6) command writes the specified number of blocks of data sent from INIT beginning at the specified logical block address on the media.

Table 4.53 CDB of WRITE (10) command

Bit Byte	7	6	5	4	3	2	1	0
0	Operation Code (0Ah)							
1	LUN			(MSB)				
2	Logical Block Length							
3								
4	Transfer Length							
5	Reserved							

Logical Block Address specifies the logical block address at which the command should start writing data. Transfer Length specifies the number of consecutive logical blocks of data to be transferred. If Transfer Length is 00h, the command assumes that 100h is specified. If the value is other than 00h, the command assumes it to be the number of logical blocks to be transferred.

- If the alternate blocks become insufficient during alternate block assignment, the CHECK CONDITION status is reported. The cause is indicated in the sense byte (Sense Key = MEDIUM ERROR [= 3]).

- The Verify mode setting in the mode parameter (Verify Control Page) can be set to omit verify processing. Omitting verify processing shortens processing time by about 25%.

4.3.15 WRITE (10) command

Table 4.54 WRITE (10) command

Bit Byte	7	6	5	4	3	2	1	0
0	Operation Code (2Ah)							
1	LUN			Reserved				
2-5	Logical Block Address							
6	Reserved							
7-8	Transfer Length							
9	Reserved							

The WRITE (10) command receives the specified number of blocks of data and begins writes it beginning at the specified logical block address. Logical Block Address specifies the logical block address at which the command should start writing data. Transfer Length specifies the number of blocks of data to be transferred and written. If Transfer Length is 0, the command transfers no data. It simply ends normally without writing any data.

4.3.16 WRITE AND VERIFY

Table 4.55 WRITE AND VERIFY command

Bit Byte	7	6	5	4	3	2	1	0
0	Operation Code (2Eh)							
1	LUN			Reserved			ByteChk	Reserved
2-5	Logical Block Address							
6	Reserved							
7-8	Transfer Length							
9	Reserved							

The WRITE AND VERIFY command receives the specified number of blocks of data and writes it beginning at the specified logical block address. Logical Block Address specifies the logical block address at which the command should start writing data. Transfer Length specifies the number of blocks of data to be transferred and written.

The ByteChk bit controls data compare processing. However, since the ODD does not support ByteChk, it must be set to 0. If 1 is specified, the command ends with Check Condition. If Transfer Length is 0, the command transfers no data. It simply ends normally without writing any data.

4.3.17 SEEK (6) command

Table 4.56 SEEK (6) command

Bit Byte	7	6	5	4	3	2	1	0
0	Operation Code (0Bh)							
1	LUN			(MSB)				
2	Logical Block Address							
3								
4-5	Reserved							

The SEEK (6) command performs a seek operation on the block specified by the logical block address.

- After finishing the seek operation normally, the command reports GOOD or INTERMEDIATE GOOD status. If the command fails in the seek operation, it reports CHECK CONDITION status.
- The SEEK command need not be used for READ or WRITE command operation because these types of commands include the seek function.

4.3.18 SEEK (10) command

Table 4.57 SEEK (10) command

Bit Byte	7	6	5	4	3	2	1	0
0	Operation Code (2Bh)							
1	LUN			Reserved				
2-5	Logical Block Address							
6-9	Reserved							

The SEEK (10) command positions the disk head on the track at a specified logical address. Logical Block Address specifies the logical block address at which the disk head is to be positioned.

4.3.19 ERASE command

Table 4.58 ERASE command

Bit Byte	7	6	5	4	3	2	1	0
0	Operation Code (2Ch)							
1	LUN			Reserved				
2-5	Logical Block Address							
6	Reserved							
7-8	Transfer Length							
9	Reserved							

The ERASE command erases the specified number of blocks of data beginning at the specified logical block address. Logical Block Address specifies the logical block address at which the command should start writing data. Transfer Length specifies the number of blocks of data to be transferred and written.

If Transfer Length is 0, the command transfers no data. It simply ends normally without erasing any data.

4.3.20 SYNCHRONIZE CACHE command

Table 4.59 SYNCHRONIZE CACHE command

Bit Byte	7	6	5	4	3	2	1	0
0	Operation Code (35h)							
1	LUN			Reserved			IMMED	Reserved
2-5	Logical Block Address							
6	Reserved							
7-8	Number of Blocks							
9	Reserved							

The SYNCHRONIZE CACHE command writes data that has been left unwritten in cache memory in the data buffer to media.

The Immediate (IMMED) bit is not supported. If 1 is specified for the IMMEDIATE bit, the command responds with Check Condition. The command writes all data left unwritten in cache memory in the data buffer to media regardless of the values specified for Logical Block Address and Number of Blocks. The command does not check the values of Logical Block Address and Number of Blocks.

4.3.21 FORMAT UNIT command

Table 4.60 FORMAT UNIT command

Bit Byte	7	6	5	4	3	2	1	0
0	Operation Code (04h)							
1	LUN			FmtData	CmpList	Defect List Format		
2	Reserved						0	0
3-4	Interleave							
5	Reserved							

The FORMAT UNIT command physically formats media according to the specified parameter values.

If the FmtData bit is 1, a FORMAT UNIT parameter list must be transferred. The command ignores Defect List Format. If the FmtData bit is 0, the command formats the media according to the internal default values without transferring a FORMAT UNIT parameter list. The command ignores the CmpList bit.

The command always uses the internal default value for Interleave even if a value is specified for it.

Table 4.61 FORMAT UNIT parameter list

Bit Byte	7	6	5	4	3	2	1	0
0-3	Defect List Header							

Table 4.62 Defect List Header

Bit Byte	7	6	5	4	3	2	1	0
0	Reserved							
1	Reserved		DCRT	Reserved			IMMED	Reserved
2-3	Defect List Length							

If the Disable Certification (DCRT) bit is 1, the ODD formats the media without checking it. If the Immediate (IMMED) bit is 1, the ODD responds with end of processing immediately after command reception and before formatting is completed. The Ready bit of the Status register is set to 0 during formatting and set to 1 at the completion of formatting.

Defect List Length must be set to 0. If a value other than 0 is specified, the command assumes that 0 was specified.

4.3.22 READ DEFECT DATA command

Table 4.63 READ DEFECT DATA command

Bit Byte	7	6	5	4	3	2	1	0
0	Operation Code (37h)							
1	LUN			Reserved				
2	Reserved			Plist	Glist	Defect List Format		
3-6	Reserved							
7-8	Allocation Length							
9	Reserved							

The READ DEFECT DATA command transfers media defect data to INIT.

If Plist is 1, the command transfers the header and PDL. If Glist is 1, the command transfers the header and SDL. If Plist and Glist are both 0, the command transfers the header. If Plist and Glist are both 1, the command transfers PDL and SDL, arranged in ascending order.

Defect List Format supports only the formats listed in Table 4.64. If another format is specified, the command assumes 101b and reports Recovered Error.

Table 4.64 Defect List Format of READ DEFECT DATA (10) command

Defect List Format	Data format
101	Physical sector address format (first 8191 defects in the defect list)
111	Physical sector address format (defect 8192 and subsequent defects in the defect list)

Table 4.65 shows the format of the Defect list header field. Table 4.66 shows the format of the Defect descriptor field.

Table 4.65 Defect list header of READ DEFECT DATA (10) command

Bit Byte	7	6	5	4	3	2	1	0
0	00h							
1	0	0	0	Plist	Glist	Defect List Format		
2-3	Defect List length							
4-n	Defect Descriptor (s)							

Table 4.66 Defect descriptor

Byte	Defect Descriptor
0-2	Track address of defective block
3	00h
4-7	Sector address of defective block (See Table 4.67.)

Table 4.67 Sector address format

Bit Byte	7	6	5	4	3	2	1	0
0-2	00h							
3	0	Media other than 2.3 GB: 2.3-GB media:	00b 00b groove 10b land	Sector address				

4.3.23 SEND DIAGNOSTIC command**Table 4.68 SEND DIAGNOSTIC command**

Bit Byte	7	6	5	4	3	2	1	0
0	Operation Code (1Dh)							
1	LUN			Reserved		SelfTest	Reserved	Reserved
2	Reserved							
3-4	Parameter List Length							
5	Reserved							

The SEND DIAGNOSTIC command instructs diagnostic operation from INIT.

If the SelfTest bit is 1, the command diagnoses the data buffer. If an error is detected, the command responds with Check Condition. Parameter List Length specifies the data length of the diagnostic parameters to be transferred.

The functions and specifications of the diagnostic parameters are not disclosed.

4.3.24 RECEIVE DIAGNOSTIC RESULTS command**Table 4.69 RECEIVE DIAGNOSTIC RESULTS command**

Bit Byte	7	6	5	4	3	2	1	0
0	Operation Code (1Ch)							
1	LUN			Reserved				
2	Reserved							
3-4	Allocation Length							
5	Reserved							

The RECEIVE DIAGNOSTIC RESULTS command transfers the results of the diagnosis specified by the SEND DIAGNOSTIC command to INIT. The RECEIVE DIAGNOSTIC RESULTS command is issued following the SEND DIAGNOSTIC command. If the command does not follow the SEND DIAGNOSTIC command or if there is no data to be transferred, the command ends normally without transferring any data.

4.3.25 WRITE BUFFER command

Table 4.70 WRITE BUFFER command

Bit Byte	7	6	5	4	3	2	1	0
0	Operation Code (3Bh)							
1	LUN			Reserved		Mode		
2	DIML	Reserved	TNFY	Reserved	Code-ID			
3-5	Buffer Offset							
6-8	Allocation Length							
9	Reserved							

The WRITE BUFFER command downloads firmware to flash ROM.

Mode must be set to 5. Otherwise, the command responds with Check Condition.

DIML must be set to 0.

If TNFY is 0 and Allocation Length is not 0, the command transfers the data to be written to flash ROM to the data buffer, checks the data for validity, then writes it to flash ROM. If TNFY and Allocation Length are both 0, the command checks the data in the data buffer for validity and writes it to flash ROM. If TNFY is 1, the command transfers the data to be written to flash ROM to the data buffer.

Code-ID specifies the type of code to be downloaded.

Allocation Length specifies the length of data to be transferred, in bytes.

Buffer Offset specifies the offset of the data to be transferred.

If the writing to flash ROM ends abnormally, the command responds with Check Condition.

IMPORTANT

If a power failure occurs or an interface cable is disconnected during downloading, flash ROM data is not guaranteed.

4.3.26 READ LONG command

Table 4.71 READ LONG command

Bit Byte	7	6	5	4	3	2	1	0
0	Operation Code (3Eh)							
1	LUN			Reserved				
2-5	Logical Block Address							
6	Reserved							
7-8	Byte Transfer Length							
9	Reserved							

The READ LONG command reads data in the data, CRC, and ECC sections from the specified logical block address.

The length of the transfer data must be a multiple of 600 (258h) bytes for 512-byte media and a multiple of 2380 (94Ch) bytes for 2048-byte media.

4.3.27 WRITE LONG command

Table 4.72 WRITE LONG command

Bit Byte	7	6	5	4	3	2	1	0
0	Operation Code (3Fh)							
1	LUN			Reserved				
2-5	Logical Block Address							
6	Reserved							
7-8	Byte Transfer Length							
9	Reserved							

The WRITE LONG command writes data in the data, CRC, and ECC sections from the specified logical block address.

The length of the transfer data must be a multiple of 600 (258h) bytes for 512-byte media and a multiple of 2380 (94Ch) bytes for 2048-byte media.

4.4 SCSI Messages

SCSI messages are used to control the SCSI bus operating sequence. This section explains how SCSI messages work.

4.4.1 Message formats

There are three types of message formats. In any format, the first byte of each message is a message code (see Table 4.73).

- 1-byte message: Only the message code
- 2-byte message: Message with a message code from 20h to 2Fh. Each 2-byte message consists of a 1-byte message code and a 1-byte parameter. (The ODD does not support this type of messages).
- Extended message: Multiple-byte message with message code 01h. An extended message code and message length are defined in each message.

4.4.2 Message types

Table 4.73 lists the types of messages provided by the ODD.

Table 4.73 Types of messages provided by ODD

Message code (hex)	Message	Byte count	Transfer direction	ATN release
00	Command Complete	1	TARG → INIT	
01	Extended Message (Synchronous Data Transfer Request)	n+2 (5)	TARG ↔ INIT	INIT
02	Save Data Pointer	1	TARG → INIT	
04	Disconnect	1	TARG → INIT	
05	Initiator Detected Error	1	TARG ← INIT	INIT
06	Abort	1	TARG ← INIT	INIT
07	Message Reject	1	TARG ← INIT	INIT
08	No Operation	1	TARG ← INIT	INIT
09	Message Parity Error	1	TARG ← INIT	INIT
0C	Bus Device Reset	1	TARG ← INIT	INIT
80 ↓ FF	Identify	1	TARG ↔ INIT	

4.4.3 Message functions

This section explains the function of each message. The symbols in the following explanations have the following meanings:

(I → T): Message that can only be sent from INIT to TARG

(T → I): Message that can only be sent from TARG to INIT

(I ↔ T): Message that can be sent between TARG and INIT in either direction

(1) COMMAND COMPLETE message: 00h (T → I)

The execution of a single command ended and valid status information was reported to INIT. The function of the message is to report the validity of status information; the message does not always indicate that the command ended normally. The command end status is indicated in the status byte transferred in the STATUS phase before the message is sent. Even if command transfer was not executed normally (because of such reasons as the occurrence of a parity error in the SCSI data bus in the MESSAGE OUT or COMMAND phase), TARG always sends this message after the STATUS phase if TARG reports the status byte to INIT.

After sending this message normally, TARG shifts to the BUS FREE phase. TARG assumes that message transmission was completed normally if the ATN signal is FALSE when the ACK signal changes to FALSE at the completion of the transfer of this message.

(2) SAVE DATA POINTER message: 02h (T → I)

This message instructs INIT to save the current data pointer.

(3) DISCONNECT message: 04h (T → I)

This message notifies INIT that TARG has temporarily disconnected the SCSI bus. After sending this message normally, TARG shifts to the BUS FREE phase to complete disconnection. TARG then continues command processing internally. It reconnects INIT when TARG needs to continue command execution on the SCSI bus.

(4) INITIATOR DETECTED ERROR message: 05h (I → T)

This message notifies TARG that INIT detected an error for which TARG can retry command processing. The cause of the error can be something related to operation on the SCSI bus or something attributable to INIT internal operation that is not directly related to operation on the SCSI bus.

(5) ABORT message: 06 (I - > T)

This message instructs TARG to clear the I/O operation being executed by INIT. Upon receipt of this message, TARG interrupts the current operation and shifts to the BUS FREE phase. The pending data and status related to the interrupted operation and sense data hold state are all cleared. This message has no effect on the operation started by another INIT.

(6) MESSAGE REJECT message: 07h (I → T)

The message received most recently is invalid or unsupported.

(7) NO OPERATION message: 08h (I → T)

This message causes no operation.

(8) MESSAGE PARITY ERROR message: 09h (I → T)

This message notifies TARG that a parity error was detected in the last message, in the last byte received by the INIT.

(9) BUS DEVICE RESET message: 0Ch (I → T)

This message instructs the clearing of all I/O operations (commands) being executed or stacked in TARG. TARG performs initialization by clearing not only I/O operations started by the INIT that sends this message but also all INIT I/O operations.

(10) IDENTIFY message: 80h-FFh (I ↔ T)

Bit	7	6	5	4	3	2	1	0
	1	D	0	0	0	LUN		

This message specifies the device addresses (LUN) of devices (logical units) under TARG control to establish I/O operation paths between INIT and TARG.

a. Bit 6: Disconnect Privilege

If INIT specifies this bit as 1, TARG can execute disconnection. If it specifies 0, TARG cannot execute disconnection.

b. Bits 2 to 0: LUN

These bits specify a logical unit under TARG control.

c. Message function

After the SELECTION phase, INIT first sends this message to TARG to specify the logical units to be used for I/O operation. Similarly, after the RESELECTION phase, TARG first sends this message to INIT to specify the logical units to be reconnected.

(11) SYNCHRONOUS DATA TRANSFER REQUEST message (I → T)

Byte	0	1	2	3	4
	01h	03h	01h	m	x

This message defines the parameters for synchronous data transfer between two SCSI devices. Transfer Period specifies the data transfer rate. REQ/ACK Offset that can be specified for the ODD ranges from 0 to 15. If REQ/ACK Offset is 0, asynchronous transfer is used.

Table 4.74 lists the values of Transfer Period and the corresponding synchronous transfer rates.

Table 4.74 Transfer mode settings requested by INIT to ODD

Transfer Period requested by INIT	Transfer Period acknowledged by ODD	Transfer mode used
00h ~ 0Ch	0x0Ch	Synchronous transfer (20 MBps) REQ period \geq 50 ns ACK period \geq INIT-specified value
0Dh ~ 12h	0x12h	Synchronous transfer (13.3 MBps) REQ period \geq 75 ns ACK period \geq INIT-specified value
13h ~ 19h	0x19h	Synchronous transfer (10 MBps) REQ period \geq 100 ns ACK period \geq INIT-specified value
1Ah ~ 25h	0x25h	Synchronous transfer (6.6 MBps) REQ period \geq 150 ns ACK period \geq INIT-specified value
26h ~ 32h	0x32h	Synchronous transfer (5.0 MBps) REQ period \geq 200 ns ACK period \geq INIT-specified value
33h ~ 3Fh	0x3Fh	Synchronous transfer (4.0 MBps) REQ period \geq 250 ns ACK period \geq INIT-specified value
40h ~ 4Bh	0x4Bh	Synchronous transfer (3.3 MBps) REQ period \geq 300 ns ACK period \geq INIT-specified value
4Ch ~ 7Dh	0x7Dh	Synchronous transfer (2.0 MBps) REQ period \geq 500 ns ACK period \geq INIT-specified value
7Eh ~	INIT-specified value REQ/ACK Offset = 0	Asynchronous transfer

4.5 Timing Rule

Table 4.75 Timing specifications (1 of 3)

No.	Name	Standard	Timing specification
1	Arbitration Delay	2.4 μ s min.	The minimum wait period between the time the SCSI device sends a BSY signal and the time the value on the data bus for determining the priority of bus use is judged in the ARBITRATION phase. A maximum time is not defined.
2	Assertion Period	90 ns min.	Minimum pulse width of an ACK signal sent by INIT and an REQ signal sent by TARG for synchronous data transfer.
3	Bus Clear Delay	800 ns max.	<p>Maximum allowable period between the time either of the following events occurs and the time the SCSI device stops driving all bus signals.</p> <p>(1) Detection of the BUS FREE phase (when both BSY and SEL signal become false during Bus Settle Delay).</p> <p>Note:</p> <p>Maximum allowable period between the time both BSY and SEL signal became false and the time the bus is released is 1,200 ns.</p> <p>An SCSI device that requires a period longer than Bus Settle Delay for the detection of the BUS FREE phase must release the bus within (Bus Clear Delay) minus (Bus Settle Delay excess time).</p> <p>(2) Another SCSI device asserts the SEL signal during an ARBITRATION phase.</p> <p>(3) The RST signal becomes true (RESET condition).</p>
4	Bus Free Delay	800 ns min.	Minimum wait period between the time the SCSI device detects a BUS FREE phase and the time it sends a BSY signal to initiate an ARBITRATION phase.
5	Bus Set Delay	1.8 μ s max.	Maximum allowable period between the time an SCSI device detects a BUS FREE phase and the time it sends BSY and SCSI ID signals to initiate an ARBITRATION phase.

Table 4.75 Timing specifications (2 of 3)

No.	Name	Standard	Timing specification
6	Bus Settle Delay	400 ns min.	Minimum wait period between the time a particular control signal condition changes and the time the bus condition is stabilized.
7	Cable Skew Delay	10 ns max.	Maximum allowable difference in transmission time over the interface cable between any two bus signals from any two SCSI devices.
8	Data release Delay	400 ns max.	Maximum allowable period between the time an I/O signal changes its status from false to true and the time the INIT stops driving data bus signals.
9	Deskew Delay	45 ns min.	Time for compensation for skew involved in bus signal transmission.
10	Hold Time	45 ns min.	In synchronous data transfer mode, the minimum time during which the transfer data on the DATA BUS from the leading edge of the REQ or ACK signal pulse must be maintained to compensate for the hold time in the SCSI device receiving data.
11	Negation Period	90 ns min.	In synchronous data transfer mode, the minimum time from the trailing edge of an REQ signal to the leading edge of the next REQ signal, or from the trailing edge of an ACK signal to the leading edge of the next ACK signal.
12	Power-On to Selection Time	10 sec max.	Maximum time from when the TARG is turned on to the time the TARG can post the correct status and sense data for the TEST UNIT READY, INQUIRY or REQUEST SENSE command.
13	Reset to Selection Time	250 ms max.	Maximum time from when the RESET condition (hard RESET) is released to the time the TARG can post the correct status and sense data for the TEST UNIT READY, INQUIRY or REQUEST SENSE command.
14	Reset Hold Time	25 μ s min.	The minimum time during which the RST signal must be held true to create a RESET condition. A maximum time is not defined.
15	Selection Abort Time	200 μ s max.	In a SELECTION or RESELECTION phase, the maximum allowable period between the time the SCSI device recognizes itself as selected and the time it replies with a BSY signal.

Table 4.75 Timing specifications (3 of 3)

No.	Name	Standard	Timing specification
16	Selection Timeout Delay	250 ms min. [Recommended value]	In a SELECTION or RESELECTION phase, the minimum time during which the INIT or TARG waits for a BSY signal from the SCSI device to be selected before it initiates timeout processing.
17	Transfer Period	–	In synchronous data transfer mode, the minimum time (minimum repetition time) from the leading edge of an REQ signal to the leading edge of the next REQ signal or from the leading edge of an ACK signal to the leading edge of the next ACK signal. The actual value is defined using a SYNCHRONOUS DATA TRANSFER REQUEST message exchanged between the INIT and TARG.

Table 4.76 FAST SCSI Timing specifications

No.	Name	Standard	Timing specification
18	Fast Assertion Period	30 ns min.	In FAST SCSI data transfer mode, minimum pulse width of an ACK signal sent by INIT and an REQ signal sent by TARG for synchronous data transfer.
19	Fast Cable Skew Delay	5 ns max.	In FAST SCSI data transfer mode, maximum allowable difference in transmission time over the interface cable between any two bus signals from any two SCSI devices.
20	Fast Deskew Delay	20 ns min.	In FAST SCSI data transfer mode, time for compensation for skew involved in bus signal transmission.
21	Fast Hold Time	10 ns min.	In FAST SCSI data transfer mode, the minimum time during which the transfer data on the DATA BUS from the leading edge of the REQ or ACK signal pulse must be maintained to compensate for the hold time in the SCSI device receiving data.
22	Fast Negation Period	30 ns min.	In FAST SCSI data transfer mode, the minimum time from the trailing edge of an REQ signal to the leading edge of the next REQ signal, or from the trailing edge of an ACK signal to the leading edge of the next ACK signal.

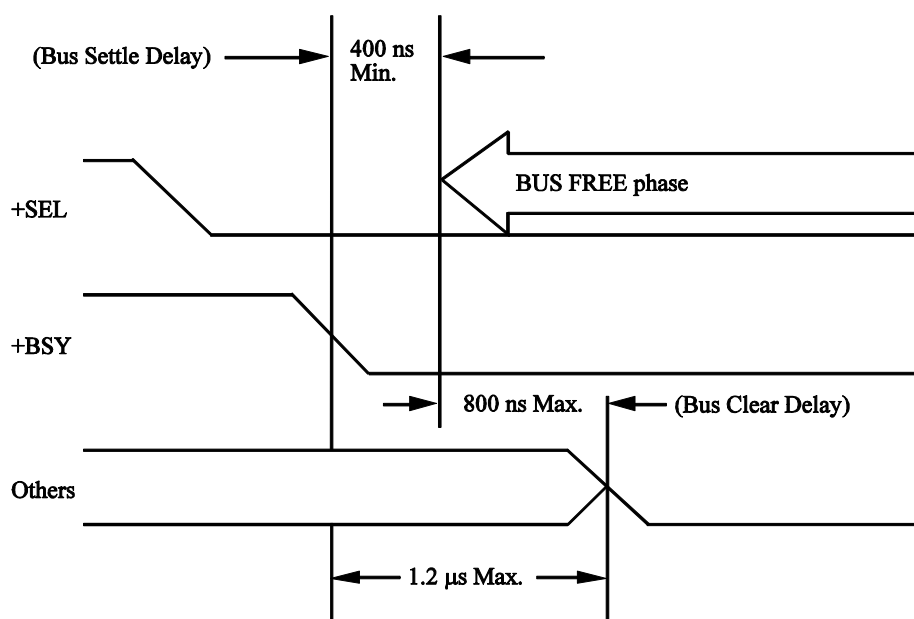
**Figure 4.4 BUS FREE phase**

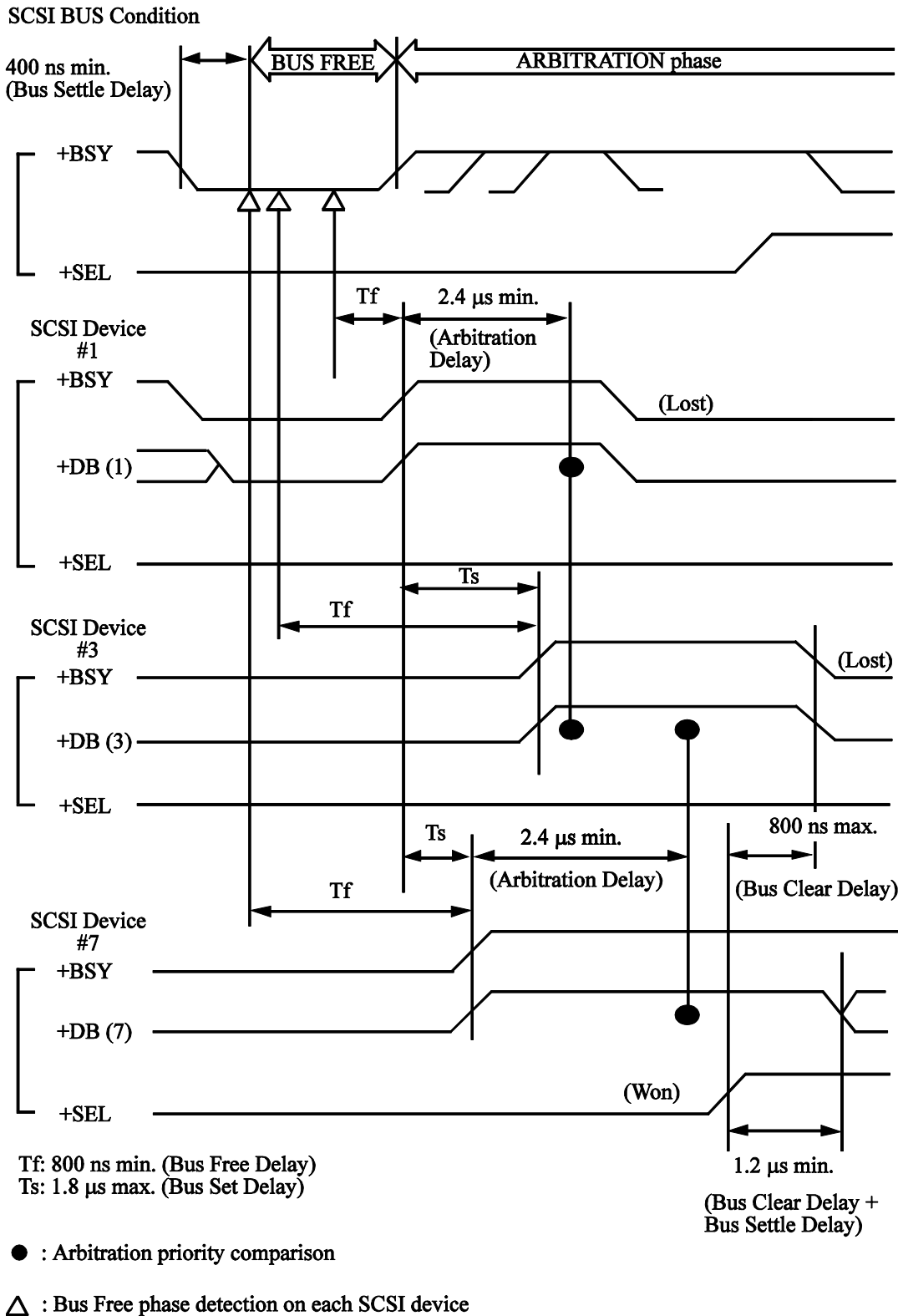

Figure 4.5 ARBITRATION phase

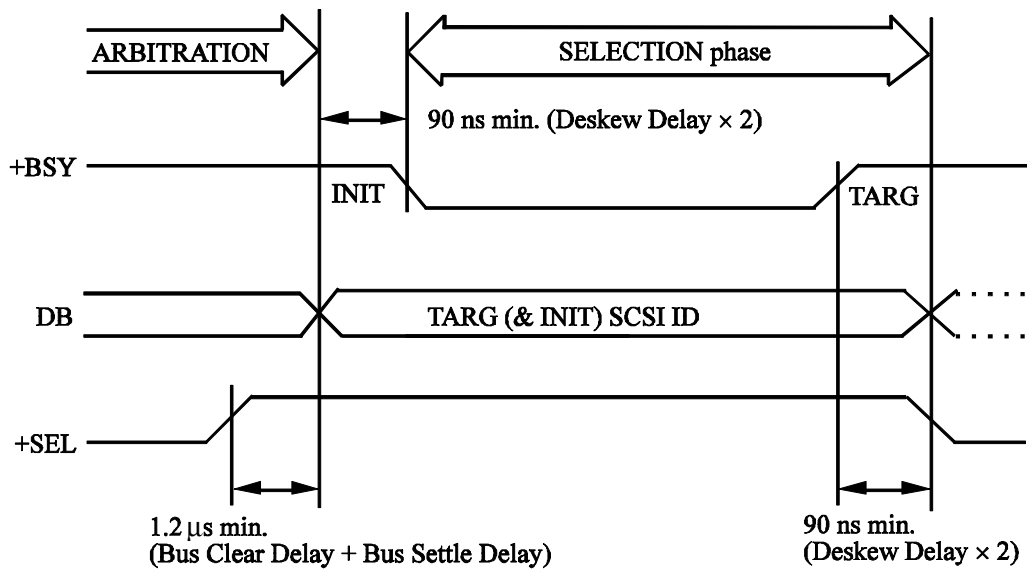

Figure 4.6 SELECTION phase

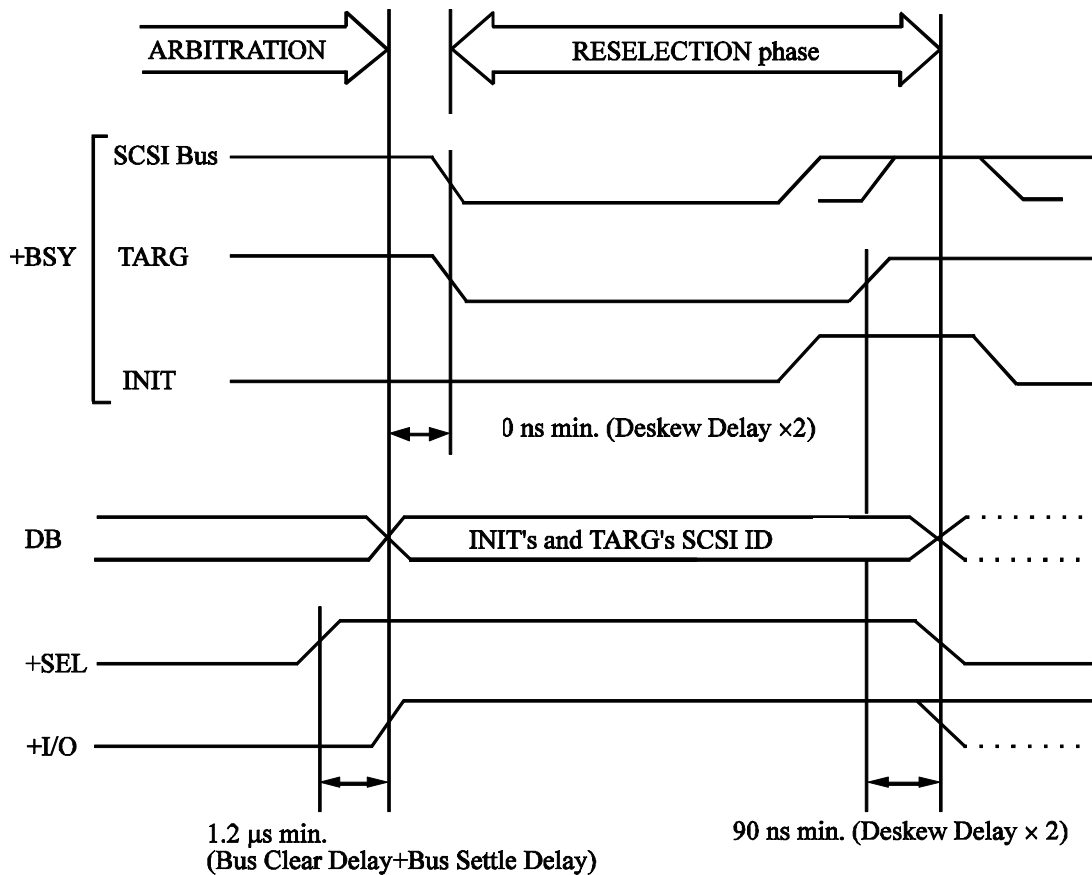
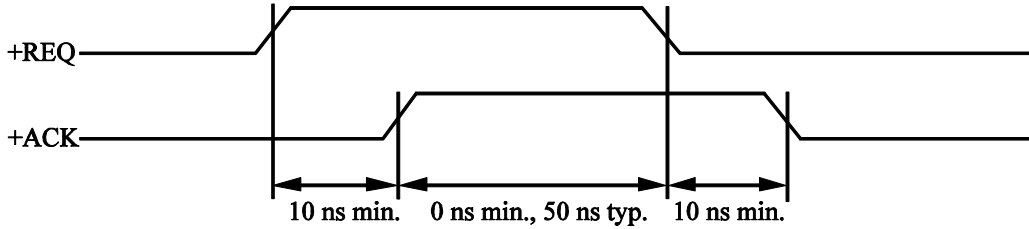

Figure 4.7 RESELECTION phase

Timing rule for REQ and ACK signals

Note: Time is defined on SCSI connector pins on the ODD.



Transfer from TARG to INIT

Note: Time is defined on SCSI connector pins on the TARG.

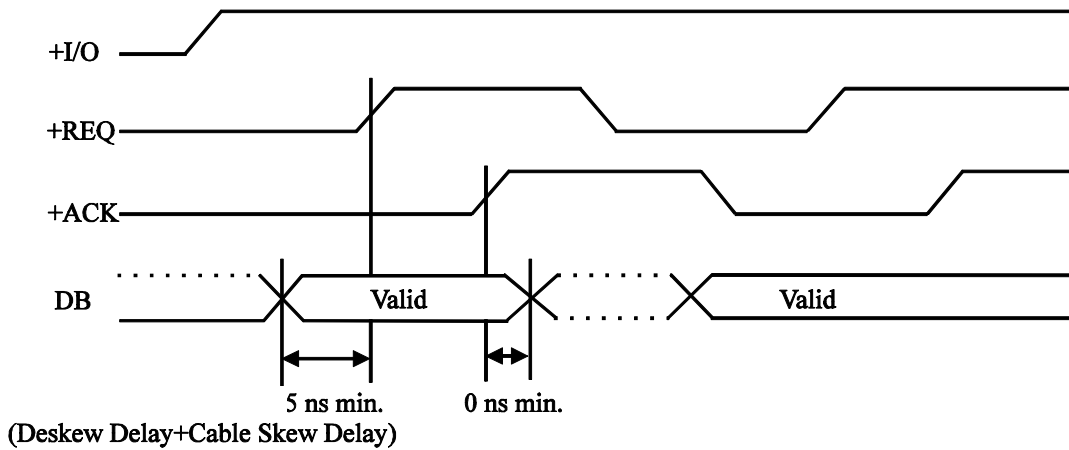

Transfer from INIT to TARG

Note: Time is defined on SCSI connector pins on the INIT.

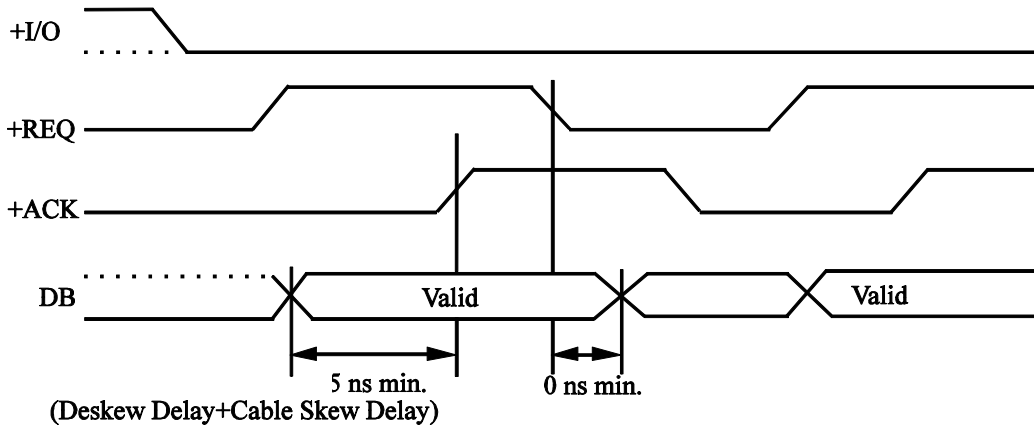
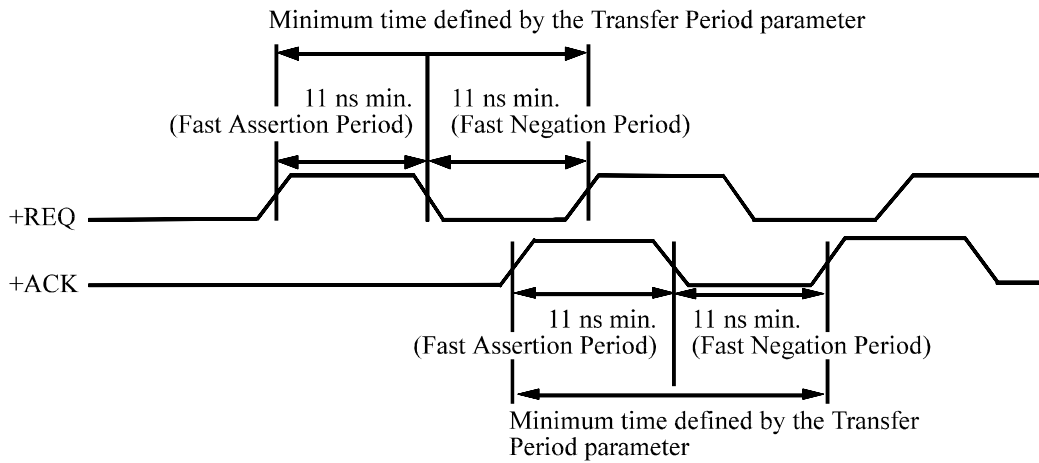

Figure 4.8 Transfer in asynchronous mode

Timing rule for REQ and ACK signals (Fast SCSI)

Note: Time is defined on SCSI device connector pins on the signal sending side.



Transfer from TARG to INIT

Note: Time is defined on SCSI device connector pins on the TARG.

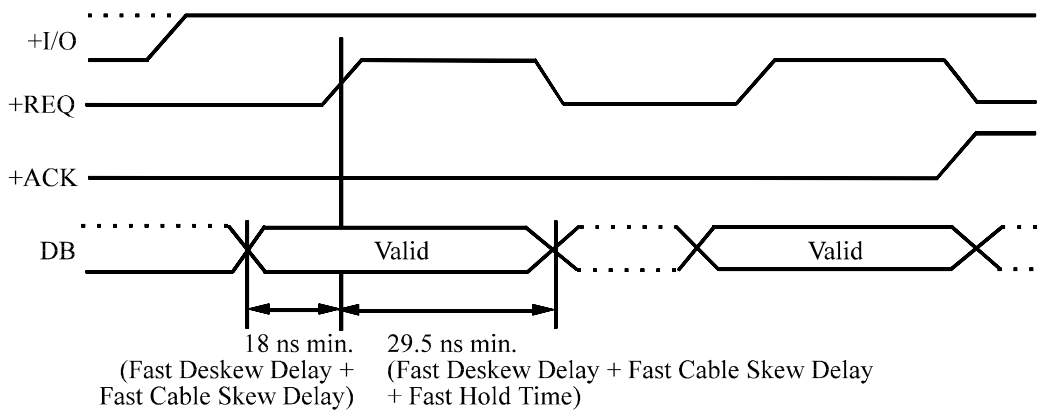

Transfer from INIT to TARG

Note: Time is defined on SCSI device connector pins on the INIT.

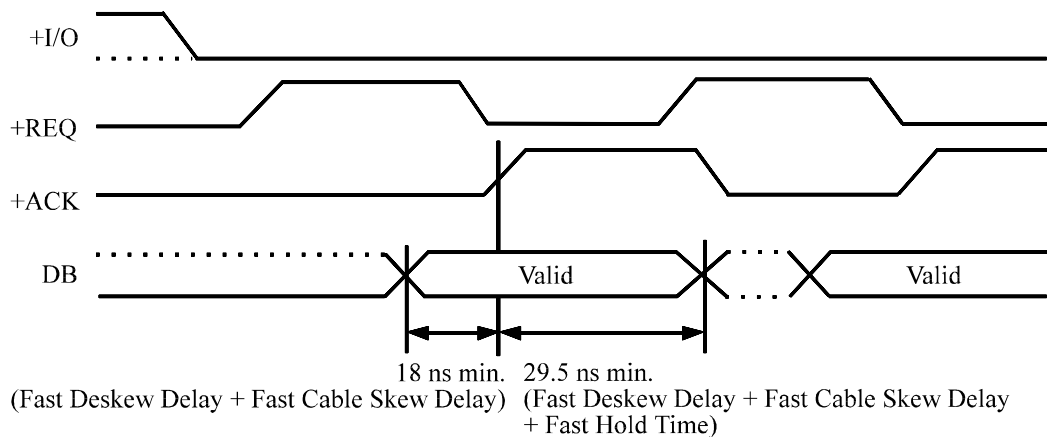
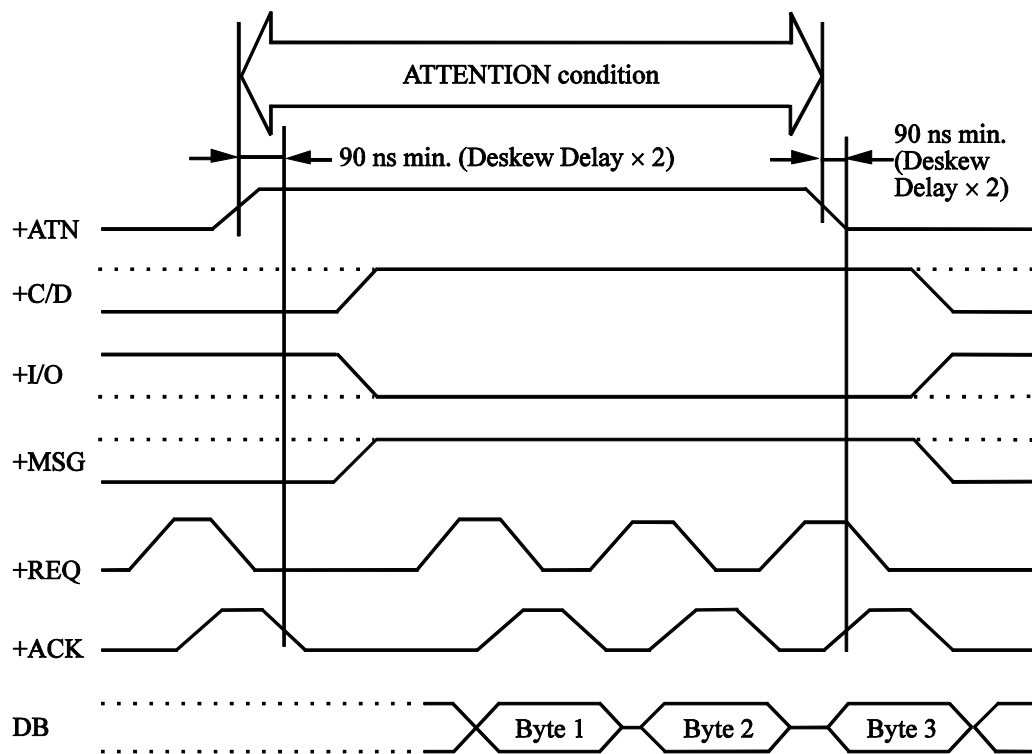

Figure 4.9 Transfer in FAST SCSI mode



Note:

The time is specified at the SCSI connector terminal of the TARG.

Figure 4.10 ATTENTION condition

CHAPTER 5 Operation and Cleaning

- 5.1 Operating Optical Disk Drive
- 5.2 Cleaning Drive
- 5.3 Optical Disk Cartridge Operation
- 5.4 Cleaning Optical Disk Cartridge

This chapter describes how to operate and clean the drive and the optical disk cartridges.

5.1 Operating Optical Disk Drive

The drive has an automatic load function. All the operator must do is to insert the optical disk cartridge and operate the eject button.

This section explains loading and ejection methods, assuming that the drive is mounted horizontally. When mounted vertically, the drive is operated in the same manner as when mounted horizontally.

Figure 5.1 shows the front view of the optical disk drive. For operation, users should be familiar with the parts in the figure and their function. Loading and ejection methods are described below.

5.1.1 Optical disk drive

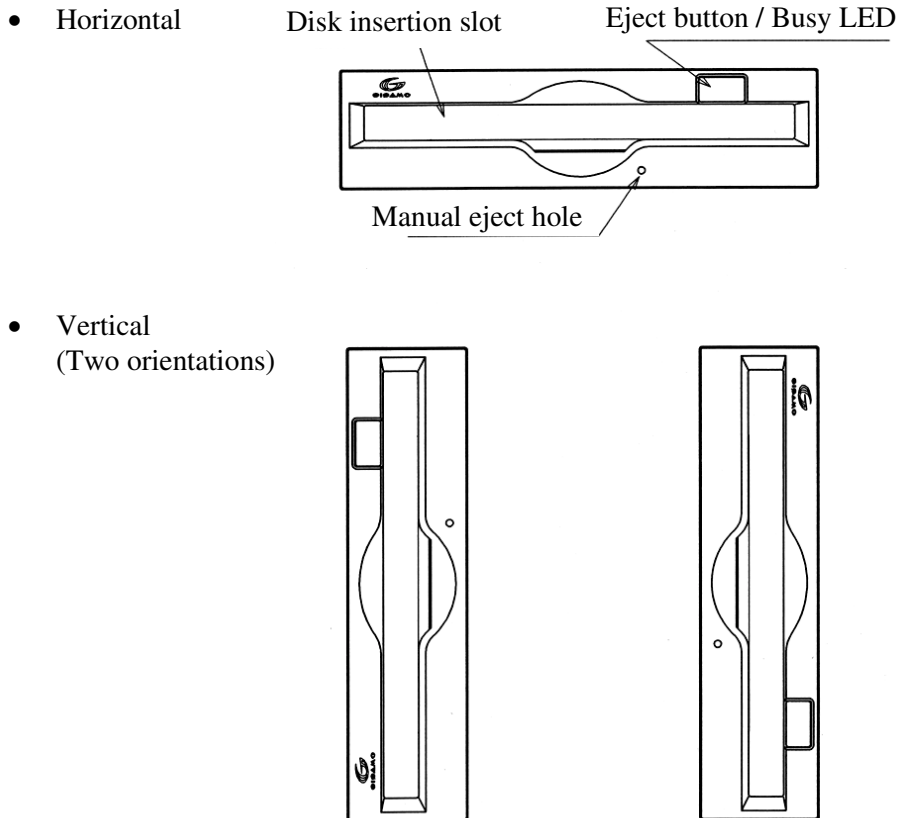

Figure 5.1 Optical disk drive front view (with panel)

The following explains the parts and functions of the optical disk drive (the following numbers correspond to the numbers in Figures 5.1):

1) Disk insertion slot

Use this slot to insert and eject the optical disk cartridge.

2) Eject button & BUSY LED (display lamp)

On this optical disk drive, this is the push button combining the eject button with the BUSY LED (display lamp) for ejecting the optical disk cartridge (it lights in green during seeking and during erasing, writing or reading of data). When ejection is disabled by the SCSI command, the optical disk cartridge cannot be taken out.

3) Manual eject hole

This hole is used to eject the optical disk cartridge manually at power-off. Manual ejection may not be possible just after the power is off.

5.1.2 Note

To maintain the performance and reliability of the drive, keep the following point in mind:

- When the drive is in the busy state, do not eject the optical disk cartridge. Particularly, do not manually eject the cartridge by force.
- Be careful sufficiently not to insert the different drive (etc. floppy disk) or substance, so it is cause of the accident.

5.1.3 Inserting cartridge

Insert the cartridge as explained below. (See figure 5.2)

(1) When the drive power is on:

- 1) Make sure that no disk cartridge is in the drive.
- 2) Keep the cartridge shutter surface upward.
- 3) Insert the cartridge, shutter first, into the disk insertion slot.
- 4) Push the cartridge into the slot until it completes moving below (a little further in than the operator panel).

Loading is started when the cartridge is inserted. After several seconds, the BUSY LED indicator lamp is turned on and immediately turned off to complete loading.

Notes

- 1) The cartridge must be completely inserted until the BUSY LED indicator lamp is lit.
- 2) If the cartridge is inserted by pushing either left or right side of the cartridge rear, it may not be inserted completely. Be sure to push the central part straight into the drive until it is completely inserted.
- 3) If the BUSY LED indicator lamp does not light when the cartridge is inserted, once eject the cartridge by pressing the eject/BUSY LED button and insert it again.
- 4) If you attempt to insert the cartridge by force, trouble may result in the drive. In such a case, be sure to once remove the cartridge and check the insertion direction and the face and back of the cartridge before inserting it again.

(2) When the drive power is off:

- 1) Make sure that no optical disk cartridge is in the disk drive.
- 2) Keep the cartridge shutter surface upward.
- 3) Insert the cartridge, shutter first, into the disk insertion slot.

- 4) Push the cartridge into the slot until it completes moving below (a little further in than the operator panel).

The cartridge remains inserted in the drive. The BUSY LED indicator lamp lights when the drive power is turned on.

The cartridge remains inserted in the drive. Turning on the drive power starts loading. (The LED indicator lamp should light.)

Notes

- 1) If the BUSY LED indicator lamp does not light when the power is turned on, once eject the cartridge by pressing the eject button and insert it again until the lamp is lit.
- 2) If the cartridge is inserted by pushing either left or right side of the cartridge rear, it may not be inserted completely. Be sure to push the central part straight into the drive until it is completely inserted.
- 3) If you attempt to insert the cartridge by force, trouble may result in the drive. In such a case, be sure to once remove the cartridge and check the insertion direction and the face and back of the cartridge before inserting it again.

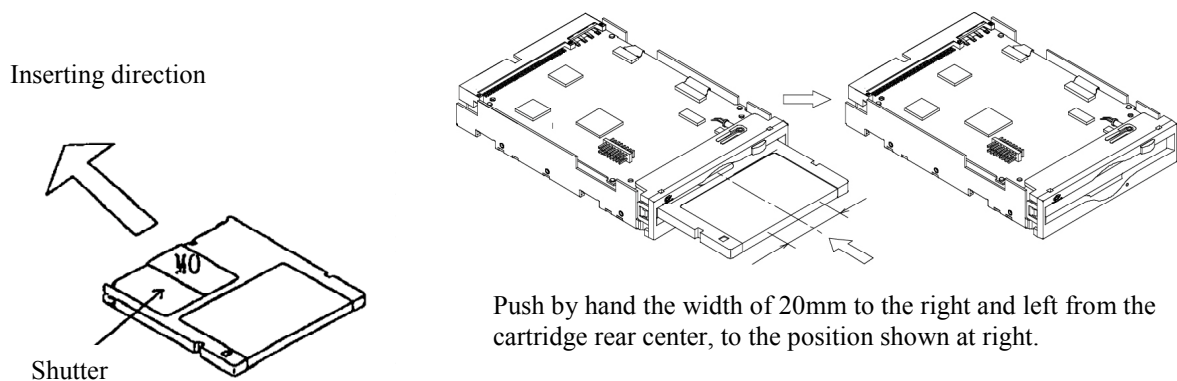

Figure 5.2 Inserting cartridge

IMPORTANT

Even if you inserted the optical disk cartridge by pressing the left side of the rear edge with the cartridge shutter surface facing upward, and you heard a chucking sound, the device may not enter the READY state. In such case, press the center of the rear edge of the cartridge (check the dint part on the front side of the panel) further, until the LED indicator lamp goes on. This lamp indicates that the cartridge is normally inserted.

5.1.4 Ejecting (removing) cartridge

Remove the cartridge as explained below.

- (1) When the drive power is on:

The cartridge can be removed by pressing the eject button. (See figure 5.3)

Notes:

- 1) If the SCSI command prevents ejection, the cartridge cannot be removed.
- 2) Even if the drive set-up conditions are met, note that the cartridge can drop from the drive after ejection depending on the ambient environment and the cartridge's condition.
- 3) Remove the cartridge when completely ejected.

- (2) When the drive power is off:

If the drive power is off, the cartridge cannot be removed by pressing the eject button. The cartridge can be removed by insert the eject jig (accessory) or a pin (diameter: about 1 mm) into the manual eject hole. (See figure 5.3)

Notes

- 1) NEVER attempt to eject the cartridge while the BUSY LED lamp is on. The data may be destroyed or trouble may result in the drive.
- 2) Note that the cartridge may drop from the drive when it is ejected.
- 3) The optical disk drive unit should not be carried around with a cartridge loaded inside.

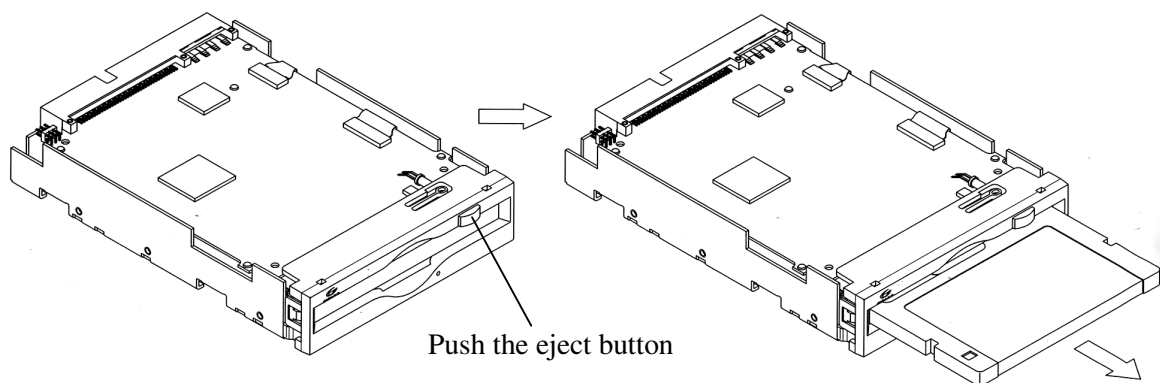

Figure 5.3 Removing cartridge

5.2 Cleaning Drive

When a dust or smoke of cigarette is stained to the lens actuator, a performance of whole drive may be down. Clean the lens actuator periodically using following head cleaner.

Note:

Cleaning period differs depending on the installation condition. Usually, cleaning period is once a three months.

Table 5.1 Head cleaner

Part name	Product number	Order number
Head cleaner	020470	CA90002-C980

(1) Cleaning method

Clean the head actuator with following method.

1. Turn on the power of the drive.
2. Insert the head cleaner.
3. When the head cleaner is automatically loaded, the optical head positioner moves back and forth and the cleaning brush mounted on the head cleaner cleans the object lens.
4. When the cleaning is finished, the head cleaner is automatically unloaded. (cleaning time: 15 seconds)



Device Damage: Be sure to use the dedicated head cleaner described above.

IMPORTANT

Check the cleaning brush state by opening the shutter of the head cleaner. If the tip of brush is open, use new head cleaner.

5.3 Optical Disk Cartridge Operation

5.3.1 Optical disk cartridge

Figure 5.4 shows the optical disk cartridge. For operation and cleaning, users should be familiar with the parts shown in the figure.

See Subsection 2.3.2 for the functions of the parts.

- a. Shutter closed

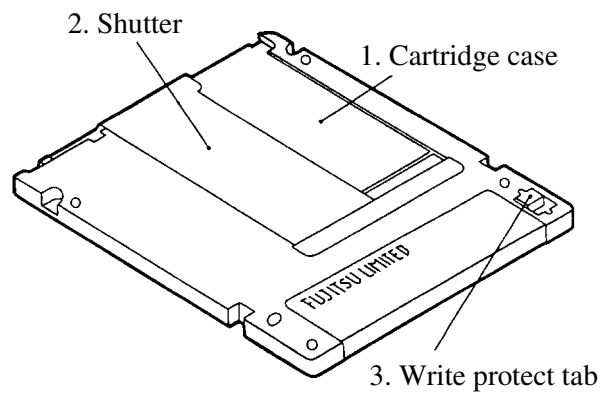

- b. Shutter open

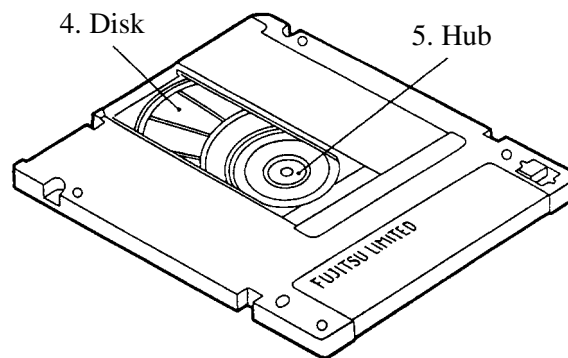
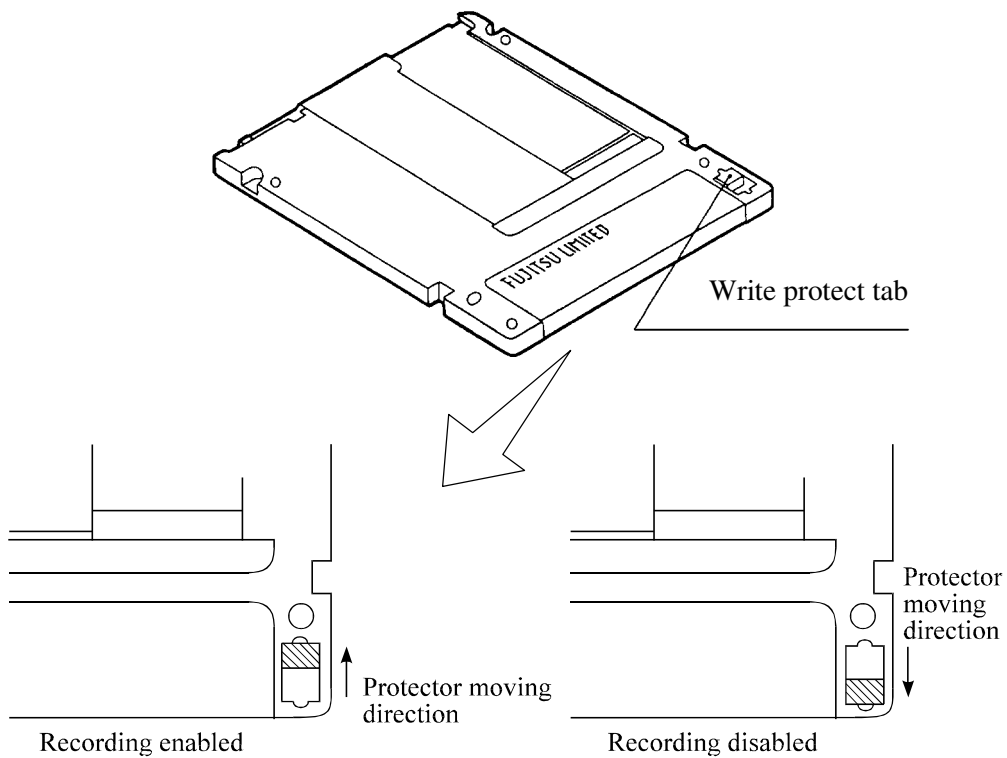

Figure 5.4 Optial disk cartridge

5.3.2 Write protect tab

Moving the write protect tab determines whether to enable or disable writing of the optical disk cartridge. Use a fingernail to move the write protect tab (it must be completely moved to the end because there is play in the middle).

Figure 5.5 shows the write protect tab location on the optical disk cartridge and the moving state of the write protect tab (see "write enabled" and "write disabled" entered on the label).



Note:

The hatched part indicates the write protect tab location.

Figure 5.5 Write protect tab

5.3.3 How to affix an index label on the MO cartridge (See figure 5.6)

(1) Note the following when affixing an index label:

- Be careful not to let the label become misaligned.
- Be sure to prevent the formation of air bubbles or peeling.

(2) How to affix an index label

Follow the procedure below when affixing an index label. (See Figure 5.x.)

- 1) Clean the surface of the MO cartridge before affixing the index label.
- 2) For a better finish, start sticking the index label from the backside of the MO cartridge.(a)
- 3) Once the backside is done, firmly press each corner of the index label.(b)
- 4) When the front is also complete, again press every corner of the index label to prevent the label from coming off.(c)

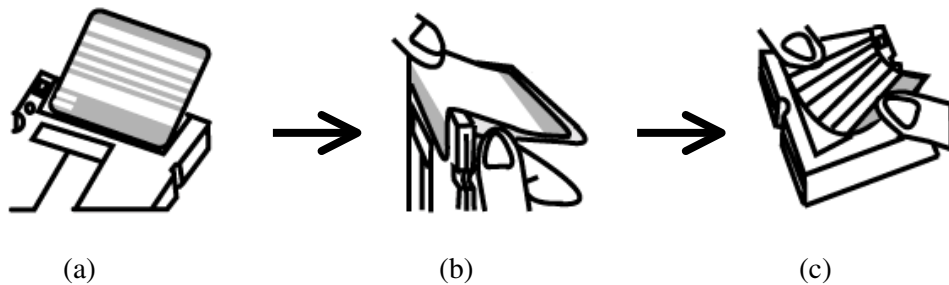

Figure 5.6 How to stick an index label on the MO cartridge

5.3.4 Notes

To maintain the performance and reliability of the optical disk cartridge, keep the following points in mind when using, storing, or transporting the cartridge:

(1) When using the cartridge:

- Do not use the cartridge where exposed to direct sunlight or where the temperature changes sharply, the temperature is high, or the humidity is high.
- Do not apply excessive pressure to the cartridge case or shutter. Avoid dropping the cartridge.
- Do not use the cartridge in a dusty or smoky place.
- Do not open the shutter or touch the disk surface.

(2) When storing the cartridge:

- Do not place a heavy objects on the cartridge.
- Do not store the cartridge where exposed to direct sunlight or where the temperature changes sharply, the temperature is high, or the humidity is high.
- Do not store the cartridge in a dusty or smoky place.

(3) When transporting the cartridge:

- Put the cartridge in a nylon bag to protect it from moisture.
- Put the cartridge in a strong container and cover the cartridge with cushioning material.

5.4 Cleaning Optical Disk Cartridge

Dust or cigarette smoke particulates on the disk surface lowers the performance of the cartridge. Regularly clean the disk. The cleaning frequency depends on the drive installation environment. Determine how often the drive should be cleaned in consideration of the environment. A standard of the cleaning period is every 300 hours usage or once a 2 to 3 months.

5.4.1 Cleaning tool

Use the cleaning kit to clean the disk cartridge.

(1) Cleaning kit

This cleaning kit is only for 3.5-inch optical disk cartridge. Use with reading the attached operation guide well. Table 5.2 shows the order number of the cleaning kit.

Table 5.2 Cleaning kit

Part name	Product number	Order number
Cleaning kit	0632440	CA90003-0702

Table 5.3 shows the packed items in the cleaning kit.

Table 5.3 Packed items (cleaning kit)

Name	Contents
Setting case	1 piece
Cleaning cloth	5 pieces (70mm × 70mm)
Cleaning solution	1 bottle (20ml)

The following sub-kit is available as a set of the cleaning solution and cleaning cloth as supplement.

- Product No. 0632450
- Order No. CA90002-D901

▲ CAUTION

Damage for disk medium: Use the cleaning solution and cleaning cloth specified in Table 5.2. If other than the specified items is used, disk media surface may be damaged.

(2) Notes on usage and storage of cleaning kit

- When storing the cleaning solution, tighten the cap.
- As the magnet is used at revolving knob of the setting case, do not place the floppy disk near the revolving knob.
- Do not use or storage where exposed to direct sun light or near the inflammables.
- Keep out of the reach of children.

▲ CAUTION

Damage for data medium: Do not use this cleaning kit for the floppy disk or the optical disk cartridge used for other optical disk drive.

5.4.2 Cleaning procedure

Clean the disk cartridge with a following procedure.

▲ CAUTION

Damage for disk medium: Clean the cartridge at clean place. Put a disposable groves at cleaning so that the fingerprint does not put on the disk media (recommendation).

- 1) Slide the shutter completely open. (See figure 5.7)

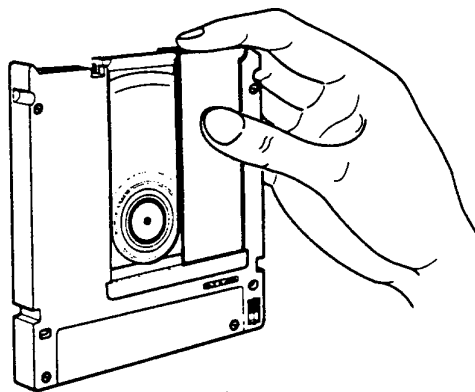

Figure 5.7 Cleaning procedure (1)

- 2) Set the cartridge with keeping label side down and shutter open to the shutter stopper of the setting case as shown in Figure 5.8.

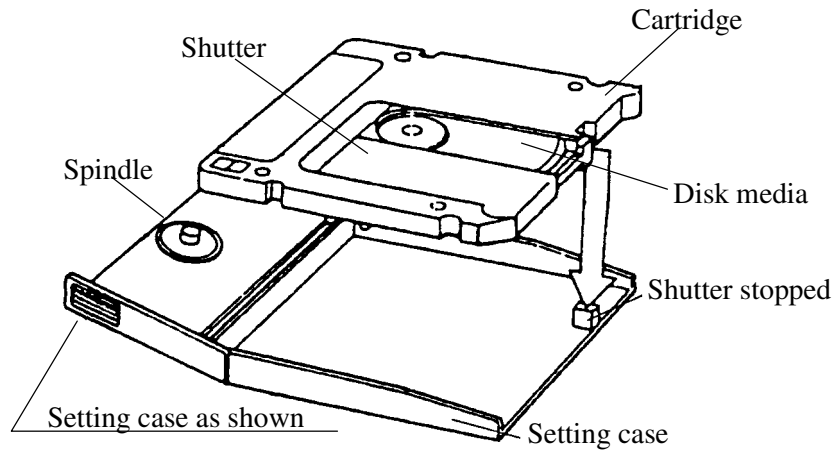

Figure 5.8 Cleaning procedure (2)

CAUTION

Damage for disk medium: At setting the cartridge to the setting case, do not apply the heavy shock and push hardly.

- 3) Cover the cartridge with the setting case cover, then insert the spindle pin into the center hub of the cartridge.

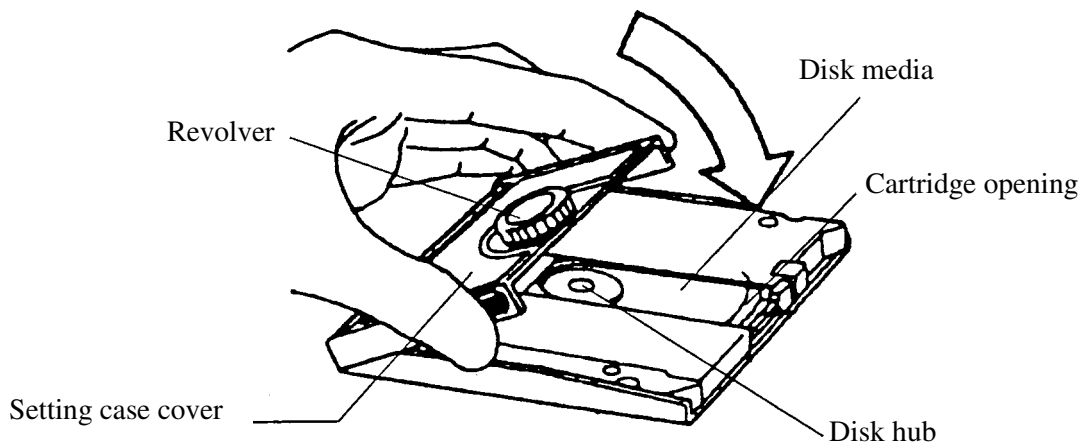

Figure 5.9 Cleaning procedure (3)

- 4) Remove a slender piece that causes a defect from the disk surface at wiping the disk media.
- 5) Moisten the cleaning cloth with a few drops of cleaning solution.

CAUTION

Eye inflammation: In case of contact with eyes, immediately flush eyes with water.

- 6) Wipe the disk surface from the hub outward.
- 7) Turn the revolving knob, then wipe the disk surface.

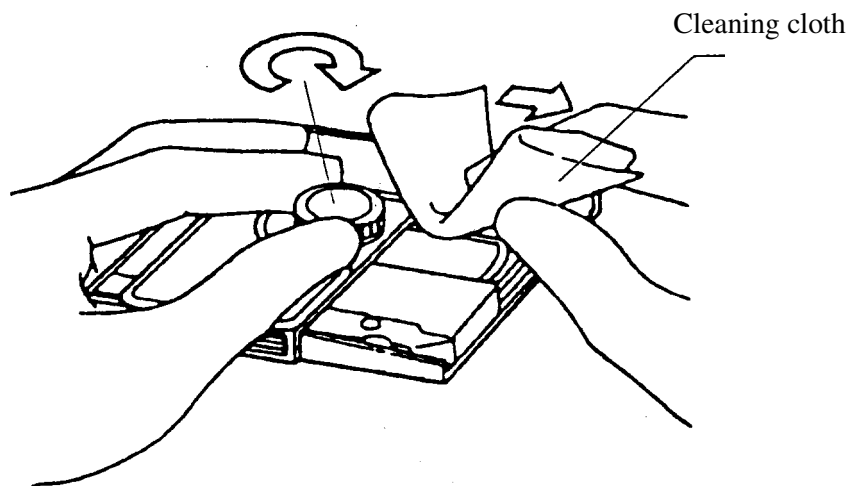

Figure 5.10 Cleaning procedure (4)

- 8) If the excess cleaning solution remains on the disk surface, wipe out with the cleaning cloth.

CHAPTER 6 Diagnosis and Maintenance

6.1 Diagnosis
6.2 Maintenance Information

This chapter contains diagnosis and maintenance information.

6.1 Diagnosis

Table 6.1 shows a test executed by the diagnostic function.

The drive has a self-diagnostic function. This function can check the basic operations of the drive.

A test program running in the host system is required to check general operations, including operations of the interface with the host system. (See Subsection 6.1.3.)

Table 6.1 Self-diagnostic function

Diagnostic contents	Target
Initial self diagnosis	Basic operation (hardware function test)
Diagnostic command	Basic operation
Test program	General operation

6.1.1 Initial self-diagnosis

When the power is turned on, the optical disk drive starts initial self-diagnosis. Basic hardware functions are tested during initial self-diagnosis.

The hardware function test checks the normality of the basic controller operation. This test includes the normality check of the ROM in which microcodes are stored, microprocessor (MPU) peripheral circuit test, memory (RAM) test, and data buffer test.

If an error is detected during initial self-diagnosis, the LED on the drive front panel blinks.

6.1.2 Diagnostic command

The host system can make the ODD execute the self diagnosis by issuing the EXECUTIVE DEVICE DIAGNOSTIC command. See Section 4.7.2, "EXECUTIVE DEVICE DIAGNOSTIC", in details.

6.1.3 Test program

A test program running in the host system is required to check general operations such as operations of the interface with the host system and simulated operations.

The configuration and function of the test program depend on the user system requirements.

The test program should include the following tests:

(1) Random/sequential read test

Use the READ or VERIFY command to test positioning (seek) operation and read operation in random access mode and sequential access mode.

(2) Write/read test

Use a disk whose operation check data may be destroyed so that a write or read test can be executed with an arbitrary data pattern.

6.2 Maintenance Information

6.2.1 Maintenance requirements

(1) Preventive maintenance

No preventive maintenance is required.

(2) Service life

No overhaul is required within the first five years if the drive is used and handled in an appropriate environment.

(3) Service system and repair

Fujitsu provides a service system and repair facility for its optical disk drive. Submit information required to replace or repair the drive to your Fujitsu representative. The following information should be included:

- a) Optical disk drive model, part number (P/N), revision number, serial number (S/N), and date of manufacture
- b) Failure status
 - Date of the failure
 - System configuration
 - Environment conditions (temperature, humidity, and supply voltage)
- c) Failure history
- d) Failure
 - Description of the failure
 - Issued commands and specified parameters
 - Sense data
 - Other error analysis information



Data loss:

In case of regular repair, the optical disk cartridge should not be attached except where the cartridge causes the error. And before having the drive repaired, save the data in the cartridge. Fujitsu is not responsible for data lost during maintenance or repair.

See Section 5.3.3 for details on packing and handling the drive when sending it to Fujitsu.

6.2.2 Revision number

The revision number of an optical disk drive is represented with an alphabetic character and a single-digit number. The revision number is shown on the revision label attached to the drive. For example, Figure 6.1 shows the revision label format.

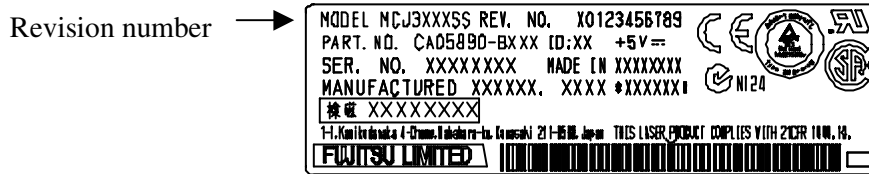

Figure 6.1 Revision label

(1) Revision number indication

When the drive is shipped, the revision number is indicated by deleting the numbers up to the corresponding number on the line of alphabetic characters. (Each number is deleted with double lines =. See Figure 6.2.)

(2) Changing the revision number on site

When the revision number is changed on site because of parts replacement or modification, the new revision number is indicated by circling the number on the line of alphabetic characters. (See Figure 6.2.)

IMPORTANT

When a revision number is changed after shipment, Fujitsu issues "Revision Number Change Request/Notice" to indicate the new revision number. The user must update the revision label as described above when changing the revision number.

Revision number indicated on shipment

REV. NO. A ~~0~~ ~~1~~ ~~2~~ 3 4 5 6 7 8 9 ⇒ Revision A2

Revision number changed on site

REV. NO. A ~~0~~ ~~1~~ ~~2~~ ③ 4 5 6 7 8 9 ⇒ Revision A3

Note: The "A" of the Revision Number is a stamp.

Figure 6.2 Revision number indication

Glossary

Axial acceleration

Acceleration on the recording layer along with the line perpendicular to the disk reference surface to a specified rotation speed. Axial acceleration is detected by optical means.

Axial displacement

A displacement at a point on the recording layer in a direction perpendicular to the disk reference surface from its original standard position. The standard position on the recording layer is detected optically using the thickness of the protective layer and refraction rate based on the disk reference surface.

Case

A cover of the optical disk. The case protects the disk from being damaged during handling and also allows the operator to exchange disks easily. The case also contains a label, write protection tab, automatic handling support, and media identification hole.

CDB (Command Descriptor Block)

A series of data describing input-output commands. CDB is sent from the initiator to the target.

Clamp area

A ring area on the disk on which a clamp force is applied by the clamp mechanism.

Command

An input-output instruction to the target. Described as CDB.

Control track

A track used to store media parameters and format information required to record and read data to or from the optical disk.

Defect management

In real time, an automatic program used to change the power, focus, tracking of reading and recording if an error is detected and to decide if many error sectors should be discarded. In batch mode, a guideline used to re-record or save the disk.

Disk reference surface

An ideal flat ring surface of an ideal spindle that is in contact with the clamp area on the disk. It is perpendicular to the rotation axis.

Error correction code

An error correction code designed to correct specific errors in data.

Error detection and correction

A series of data by adding a redundant code to data in the existing format. In read mode, the decoder removes a redundant code and detects and corrects errors using redundant information.

Interleaving section

A process that physically arranges data units so that data resists burst errors.

LUN (Logical Unit Number)

A device address used to identify a logical unit.

Recording layer

A layer on the disk on which data is recorded at production or recording .

Recording power

An incidence power specified on the incidence surface. Used to form marks.

Sense code

A single-byte code set in sense data. This information is used to determine the type of error detected.

Sense data

Information generated by the target to report detailed error information if any error information is contained in the command end status.

Sense key

A 4-bit code set in sense data. This information is used to classify the type of error detected.

Spindle

A component of the disk drive unit that is in contact with the disk and hub.

Status

A single-byte information reported from the target to the initiator at the end of each command execution. The status indicates the end status of a command.

This page is intentionally left blank.

Acronyms and Abbreviations

A		E	
AC	Alternating Current	EBC	Enable Blank Check
ACK	ACKnowledge	EBP	Erase By-Pass
ALPG	Automatic Laser Power Control	ECC	Error Correction Code
AM	Address Mark	EN	European Norm
ANSI	American National Standards Institute	EVPD	Enable Vital Product Data
ARRE	Automatic Read Reallocation Enabled	F	
ASC	Additional Sense Code	FG	Frame Ground
ASCII	American Standard Code for Information Interchange	FIFO	First In First Out
ASCQ	Additional Sense Code Qualifier	FmtData	Format data
ATN	ATteNtion	FOV	Format Options Valid
AWG	American Wire Gauge	FRU	Field Replaceable Unit
AWRE	Automatic Write Reallocation Enabled	G	
		GND	Ground
B		I	
BCV	Buffer Control Valid	I/O	Input/Output
BPV	Bit Pointer Varid	IC	Integrated Circuit
BSY	BuSY	ID	IDentifier
BytChk	Byte Check	IDD	Intelligent Disk Drive
		IEC	International Electrotechnical Commission
C		Immed	Immediate
C/D	Control/Data	IP	Initialize Pattern
CCS	Common Command Set	ISO	International Standardization Organization
CDB	Command Descriptor Block		
CDRH	Center for Devices and Radiological Health	L	
CRC	Cyclic Redundancy Code	LD	Laser Diode
CSA	Canadian Standards Association	LED	Light Emitting Diode
		LoEj	Load Eject
D		LSB	Least Significant Byte
DB	Data Bus	LUN	Logical Unit Number
DBD	Disable Block Descriptor	M	
DBP	Data Bus Parity	MPU	MicroProcessor Unit
DC	Direct Current	MSB	Most Significant Byte
DCRT	Disable CeRTification	MSG	MeSeaGe
DDS	Disk Definition Sector	MTBF	Mean Time Between Failures
DMA	Defect Management Area	MTTR	Mean Time To Repair
DPO	Disable Page Out		
DPRY	Disable PRimarY		
DSP	Digital Signal Processor		

N		SB	Spare Band
N.C.	No Connection	SCT	SeCTor
O		SDL	Secondary Defect List
ODD	Optional Disk Drive	SDTR	Synchronous Data Transfer Request
ODF	Offset Detection Flag	SEL	SElect
OEM	Original Equipment Manufacturer	SFP	Standard Formatted Part
P		SG	Signal ground
PA	PostAmble	SKSV	Sense Key Specific Valid
P/N	Part Number	SM	Sector Mark
PC	Page Control	SNSKEY	SeNSe KEY
PCA	Printed Circuit Assembly	SP	Save Page
PCF	Page Control Field	SP	Save Parameter
PCR	Parameter Code Reset	STPF	SToP Format
PDL	Primary Defect List	SYNC	SYNCronization mark
PEP	Phase Encoded Part	T	
PF	Page Format	TTL	Transister-transister-logic
PLL	Phase-Locked Loop	Typ	Typical
PMI	Partial Medium Indicator	U	
PPC	Parameter Pointer Control	UB	User Band
PWM	Pulse Width Modulation	UL	Underwriters Laboratories Incorporated
R		V	
RAM	Random-Access Memory	VCM	Voice coil motor
RelAdr	Relative Addressing	VDE	Verband Deutscher Elektrotechniker
REQ	REQuest	VFO	Variable Frequency Oscillator
RH	Relative Humidity	VLD	VaLiD
ROM	Read only Memory	VPD	Vital Product Data
rpm	revolutions per minute	VU	Vendor Unique
RST	ReSeT	S	
RSV	ReSerVed	S/N	Serial Number

Index

128 MB disk 2-9
 1.3 GB disk 2-9
 230 MB disk 2-9
 2.3 GB capacity 1-2
 2.3 GB disk 2-9
 540 MB/640 MB disk 2-9

A

ABORT message 4-43
 active mode 4-6
 actuator section 1-9
 adaptability 1-4
 air flow 3-3
 air purity 3-4
 algorithm for alternate processing 2-11
 allowable input voltage and current 3-11
 ARBITRATION phase 4-50
 ASC and ASCQ definition 4-29
 ATTENTION condition 4-54
 automatic allocation of alternate data block
 1-4
 automatic alternate sector assignment
 function 4-4
 automatic spindle stop function 1-3

B

bit 2 to 0 4-44
 bit 6 4-44
 bit error rate after ECC processing 2-5
 Block Descriptor 4-23
 block descriptor 4-15
 Bus Device Reset 4-4
 BUS DEVICE RESET message 4-44
 BUS FREE phase 4-49

C

cable connection 3-12, 3-25
 cable connector specification 3-15
 cache function 4-4
 Caching page 4-19
 cartridge case 2-9
 CDB of READ (6) command 4-32
 CDB of WRITE (10) command 4-33
 center of gravity 3-8
 changing revision number on site 6-4
 check before mounting drive 3-24
 check if error occurs at initial self-diagnosis
 3-26

cleaning drive 5-6
 cleaning kit 5-11
 cleaning optical disk cartridge 5-11
 cleaning procedure 5-12
 cleaning procedure (1) 5-12
 cleaning procedure (2) 5-13
 cleaning procedure (3) 5-13
 cleaning procedure (4) 5-14
 cleaning tool 5-11
 COMMAND COMPILE message 4-43
 compatible with international standard
 (media interchangeability) 1-3
 configuration 1-8
 confirming initial operation 3-26
 conformance to SCSI-2 1-5
 connecting more than one optical disk drive
 (multi-host) 3-17
 connecting more than one optical disk drive
 (single host) 3-16
 connecting one optical disk drive 3-16
 connection check 3-27
 connection mode 3-16
 connector and terminal location 3-12
 continuous block processing 1-5
 control circuit section 1-10
 control circuit section block diagram 1-10
 controller circuit section 1-10
 current waveform (+5 VDC) 3-11
 current waveform (reference) 3-11

D

data buffer 1-5, 4-5
 data security at power failure 2-6
 default jumper setting 3-18
 default value in Caching page 4-19
 default value in flexible disk page 4-18
 default value in Power condition page 4-20
 default value in read-write error recovery
 page 4-16
 default value in Verify control page 4-21
 defect descriptor 4-39
 defective block slipping 1-6
 defective sector management 4-4
 Defect List Format of READ DEFECT
 DATA (10) command 4-38
 Defect List Header 4-37
 defect list header of READ DEFECT DATA
 (10) command 4-38
 defect management 2-11

defect management schematic diagram 2-11
device driver software 1-6
diagnosis 6-1
diagnosis and maintenance 6-1
diagnostic command 6-2
diagnostic function 1-4
dimension (without panel) 3-6
direct-overwrite medium support 1-3
DISCONNECT message 4-43
disk 2-9
disk specification 2-9
dismounting drive 3-27
drive circuit section 1-10
drive configuration 1-7
drive connector 3-12
drive model 1-7
drive specification 2-2
dust resistance 1-3

E

ejecting (removing) cartridge 5-5
environmental and power requirement 2-4
environmental requirement 3-1
ERASE command 4-36
Error Code 4-27
error rate 2-5
error recovery 1-3
example of alternate processing 2-12
external dimension 3-5
external light source 3-10
external magnetic field 3-10

F

FAST SCSI timing specification 4-49
feature 1-2
five-year service life (no overhaul) 1-4
flexible disk page 4-17
format progress indication byte 4-30
FORMAT UNIT command 4-37
FORMAT UNIT parameter list 4-37

G

general description 1-1
general notes 3-21

H

half-height standard 90 mm (3.5-inch) size 1-2
head cleaner 5-6
high-speed data transfer 1-2
high-speed mean seek time 1-3
host interface 4-1

how to affix index label 5-9
how to affix index label on MQ cartridge 5-9
hub 2-9

I

IC (controller, read amp) 3-2
IDENTIFY message 4-44
idle mode 4-7
if processing terminates abnormally 3-27
initial operation when power is turned on 3-26
initial self-diagnosis 6-1
INITIATOR DETECTED ERROR message 4-43
INQUIRY 4-11
INQUIRY command 4-11
INQUIRY command response data 4-12
inserting cartridge 5-3, 5-4
inside optical disk cartridge 3-2
installation 3-22
installation direction 3-7
installation requirement 3-1
interface 1-5
interface connector 4-1

L

leak magnetic field 3-10
LED indication 4-8
location of setting terminal 3-12
logical track address format 4-28
lower power consumption 1-3

M

maintenability 1-4
maintenance information 6-3
maintenance requirement 6-3
mechanical section 1-9
message format 4-42
message function 4-43, 4-44
MESSAGE PARITY ERROR message 4-44
MESSAGE REJECT message 4-44
message type 4-42
model 2-1
Mode Page 4-24
mode page 4-15
mode page code 4-14
mode parameter 4-23
Mode Parameter Header 4-23
mode parameter header 4-14
mode parameter list 4-14

MODE SELECT command 4-13
MODE SENSE command 4-22
mounting 3-24
mounting frame structure 3-9
mounting frame structure and clearance 3-9
mounting procedure 3-24
mounting requirement 3-5
MO write cache 4-6
MTBF 1-3, 2-6

N

NO OPERATION message 4-44
note 5-3
note following when affixing index label 5-9
notes 5-9
notes on drive handling 3-21
notes on mounting 3-9
notes on usage and storage of cleaning kit 5-12

O

operability 1-4
operating optical disk drive 5-1
operation and cleaning 5-1
operation confirmation and preparation for use after installation 3-26
optical disk cartridge 2-8, 5-7
optical disk cartridge load/eject 1-9
optical disk cartridge operation 5-7
optical disk cartridge specification 2-7
optical disk drive 5-2
optical disk drive configuration 1-8
optical disk drive front view (with panel) 5-2
optical disk drive specification 2-1
outer view (without panel) 1-7
outer view (with panel) 1-7

P

packed item (cleaning kit) 5-11
packing 3-22
packing style 3-23
page control field 4-22
panel 1-9
panel function processing 3-10
performance 1-1
pin assignment 3-14
positioning error rate 2-5
Power condition page 4-19
power management function 4-6
power mode 4-6, 4-8

power mode transition 4-8
Power-On Reset 4-4
power-on reset 4-4
power supply requirement 3-11
pre-idle mode 4-7
PREVENT/ALLOW MEDIUM REMOVAL command 4-31
preventive maintenance 6-3
product number 2-1

R

random/sequential read test 6-2
READ (10) command 4-32
READ (6) command 4-32
read-ahead cache feature 1-5
read cache 4-5
READ CAPACITY command 4-13
READ CAPACITY data 4-13
READ DEFECT DATA command 4-38
READ LONG command 4-41
read/write error recovery page 4-15
RECEIVE DIAGNOSTIC RESULTS command 4-39
recommended component for connection 3-15
recommended optical disk cartridge specification 2-7
RELEASE command 4-26
reliability 1-3, 2-6
REQUEST SENSE command 4-26
Request Sense Data 4-27
RESELECTION phase 4-51
RESERVE command 4-25
reset response 4-4
response to Prevent, Allow, and Eject 4-31
revision label 6-4
revision number 6-4
revision number indication 6-4

S

safety standard 1-4
SAVE DATA POINTER message 4-43
SCSI bus connection mode 3-16
SCSI command 4-10
SCSI commands 4-10
SCSI ID 3-18
SCSI ID setting (CNH2) 3-18
SCSI interface connector (cable side) 4-2
SCSI interface connector (ODD side) 4-1
SCSI interface connector pin assignment (single-ended type) 4-3
SCSI message 4-42
SCSI Reset 4-4

SCSI terminating resistor mode 3-19
SCSI terminating resistor mode (CNH1)
 3-19
sector address format 4-39
SEEK (10) command 4-35
SEEK (6) command 4-35
SELECTION phase 4-51
self-diagnostic function 6-1
SEND DIAGNOSTIC command 4-39
Sense Key 4-28
separator optical section 1-9
service clearance 3-10
service life 2-6, 6-3
service system and repair 6-3
setting 3-18
setting terminal 3-18
setting terminal (CNH2) 3-18
shape of setting terminal 3-13
shutter 2-9
shutter closed 2-8, 5-7
shutter open 2-8, 5-7
specification 2-1
spindle motor 1-9
standby mode 4-7
standby timer 4-7
start, stop and eject processing 4-24
START/STOP UNIT command 4-24
storage 3-23
surface temperature measurement point 3-2
SYNCHRONIZE CACHE command 4-36
SYNCHRONOUS DATA TRANSFER
 REQUEST message 4-44
system ground 3-11

T

temperature at each measuring point
 (reference) 3-4
temperature measurement point 3-1
temperature requirement and measuring
 method 3-3
temperature requirement at measurement
 point 3-3
temperature rise under several conditions
 3-4
test program 6-2
TEST UNIT READY command 4-11
timing rule 4-46
timing specification 4-46
transfer in asynchronous mode 4-52
transfer in FAST SCSI mode 4-53
transfer mode setting requested by INIT to
 ODD 4-45
transportation 3-23

type of message provided by ODD 4-42

U

unpacking 3-21

V

variable value in Caching page 4-19
variable value in flexible disk page 4-18
variable value in Power condition page
 4-20
variable value in read-write error recovery
 page 4-16
variable value in Verify control page 4-21
various process 4-4
various radio wave standard 1-4
VERIFY command 4-33
Verify control page 4-20
Verify mode 4-21
vibration resistance (shock resistance) 1-4

W

when drive power is off 5-3, 5-5
when drive power is on 5-3, 5-5
when storing cartridge 5-10
when transporting cartridge 5-10
when using cartridge 5-9
wide operating environment 1-4
WRITE (10) command 4-34
WRITE (6) command 4-33
WRITE AND VERIFY 4-34
WRITE AND VERIFY command 4-34
WRITE BUFFER command 4-40
write cache feature 1-5
write cache mode 3-19
write cache mode setting 3-19
WRITE LONG command 4-41
write protect tab 2-9, 5-8
write/read test 6-2

Comments concerning this manual can be directed to one of the following addresses:

FUJITSU LIMITED

Storage Product Group
4-1-1, Kamikodanaka, Nakahara-ku, Kawasaki
211-8588, Japan
TEL: 81-44-754-8350
FAX: 81-44-754-8351

FUJITSU COMPUTER PRODUCTS OF AMERICA, INC.

2904 Orchard Parkway, San Jose,
California 95134-2009, U.S.A.
TEL: 1-408-432-6333
FAX: 1-408-894-1709

FUJITSU CANADA INC.

2800 Matheson Blvd. East, Mississauga, Toronto,
Ontario L4W 4X5, CANADA
TEL: 1-905-602-5454
FAX: 1-905-602-5457

FUJITSU EUROPE LIMITED

Hayes Park Central
Hayes End Road
hayes UB4 8FE, U.K.
TEL: 44-20-8573-4444
FAX: 44-20-8573-2643

FUJITSU DEUTSCHLAND GmbH

Frankfurter Ring 211, 80807 München, GERMANY
TEL: 49-89-323780
FAX: 49-89-32378100

FUJITSU NORDIC AB

Kung Hans Väg 12, S-192 68 Sollentuna, SWEDEN
TEL: 46-8-626-6000
FAX: 46-8-626-6711

FUJITSU ITALIA S.p.A.

Via Nazario Sauro, 38 20099 Sesto S. Giovanni (MI), ITALY
TEL: 39-2-26294-1
FAX: 39-2-26294-201

FUJITSU FRANCE S.A.

1, Place des Etas-Unis, SILIC 310,
94588 Rungis Cedex, FRANCE
TEL: 33-1-41-80-38-80
FAX: 33-1-41-80-38-66

FUJITSU ICL ESPAÑA S.A.

Almagro 40, 28010 Madrid, SPAIN
TEL: 34-91-581-8000
FAX: 34-91-581-8300

FUJITSU AUSTRALIA LIMITED

2 Julius Avenue (Cnr Delhi Road) North Ryde N.S.W. 2113,
AUSTRALIA
TEL: 61-2-9776-4555
FAX: 61-2-9776-4556

FUJITSU HONG KONG LTD.

10/F., Lincoln House, 979 King's Road, Taikoo Place, Island
East, Hong Kong
TEL: 852-2827-5780
FAX: 852-2827-4724

FUJITSU KOREA LTD.

Coryo Finance Center Bldg, 23-6, YoulDo-Dong,
Young DungPo-Gu, Seoul, Republic of KOREA
TEL: 82-2-3787-6000
FAX: 82-2-3787-6029

FUJITSU COMPUTERS (SINGAPORE) PTE. LTD

20 Science Park Road #03-01,
TELETECH PARK SINGAPORE SCIENCE PARK II,
Singapore 117674
TEL: 65-777-6577
FAX: 65-771-5669

FUJITSU TAIWAN LTD.

8F, Hun Tai Center, 168-170, Tun Hwa North Road,
1st Sec., Taipei, TAIWAN
TEL: 886-2-545-7700
FAX: 886-2-717-4644

FUJITSU SYSTEMS BUSINESS (THAILAND) LTD.

12th Fl., Olympia Thai Tower, 444 Rachadapisek Road,
Samsennok, Huay Kwang, Bangkok 10320, Thailand
TEL: 66-2-512-6066
FAX: 66-2-512-6068

This page is intentionally left blank.

READER'S COMMENT FORM

Your comments or suggestions on this document are cordially solicited. For any comments and suggestions you may have, please complete and submit this form to your FUJITSU representative. The comments and suggestions will be used in planning future editions. Thank you for your cooperation.

Date issued: _____ Manual name: MCJ3230SS OPTICAL DISK
DRIVE PRODUCT MANUAL

Name: _____ Manual code: C156-E224-01EN
Company or organization: _____

Address: _____

Comments:

Page	Line	Comments

Reply requested: Yes No

Please evaluate overall quality of this manual by marking (√) in the appropriate boxes.

	Good Fair Poor		Good Fair Poor		Good Fair Poor
Organization:	<input type="checkbox"/> <input type="checkbox"/> <input type="checkbox"/>	Use of examples:	<input type="checkbox"/> <input type="checkbox"/> <input type="checkbox"/>	Legibility:	<input type="checkbox"/> <input type="checkbox"/> <input type="checkbox"/>
Accuracy:	<input type="checkbox"/> <input type="checkbox"/> <input type="checkbox"/>	Index coverage:	<input type="checkbox"/> <input type="checkbox"/> <input type="checkbox"/>	Handiness/Binding:	<input type="checkbox"/> <input type="checkbox"/> <input type="checkbox"/>
Clarity:	<input type="checkbox"/> <input type="checkbox"/> <input type="checkbox"/>	Cross referencing:	<input type="checkbox"/> <input type="checkbox"/> <input type="checkbox"/>	_____ (Others):	<input type="checkbox"/> <input type="checkbox"/> <input type="checkbox"/>
Figures & tables:	<input type="checkbox"/> <input type="checkbox"/> <input type="checkbox"/>	General appearance:	<input type="checkbox"/> <input type="checkbox"/> <input type="checkbox"/>		
Technical level:	Too high <input type="checkbox"/>	Appropriate <input type="checkbox"/>	Too low <input type="checkbox"/>		
Overall rating of this publication:	Good <input type="checkbox"/>	Fair <input type="checkbox"/>	Poor <input type="checkbox"/>		

FOR FUJITSU USE

Overseas office: _____ Person in charge: _____

Note) Local representative should pass this form to the section in charge of distribution in FUJITSU.

Reply

By _____

FUJITSU

Free Manuals Download Website

<http://myh66.com>

<http://usermanuals.us>

<http://www.somanuals.com>

<http://www.4manuals.cc>

<http://www.manual-lib.com>

<http://www.404manual.com>

<http://www.luxmanual.com>

<http://aubethermostatmanual.com>

Golf course search by state

<http://golfingnear.com>

Email search by domain

<http://emailbydomain.com>

Auto manuals search

<http://auto.somanuals.com>

TV manuals search

<http://tv.somanuals.com>