

M3099EX/EH IMAGE SCANNER OEM MANUAL

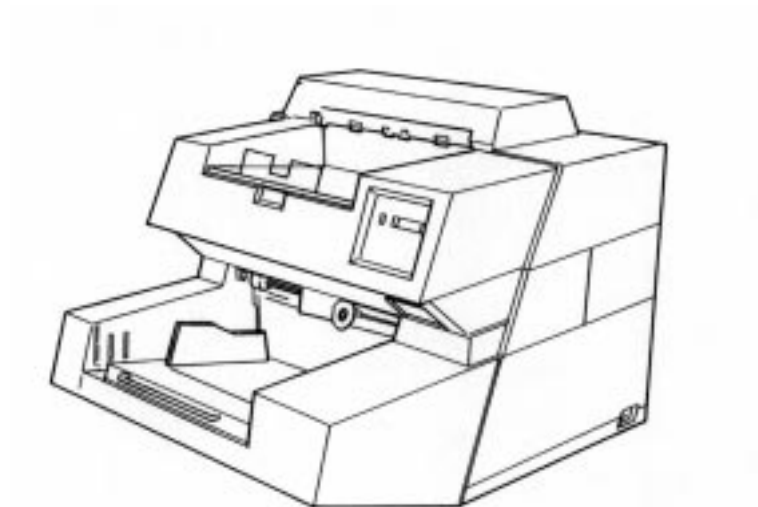

FUJITSU

M3099EX/EH IMAGE SCANNER OEM MANUAL

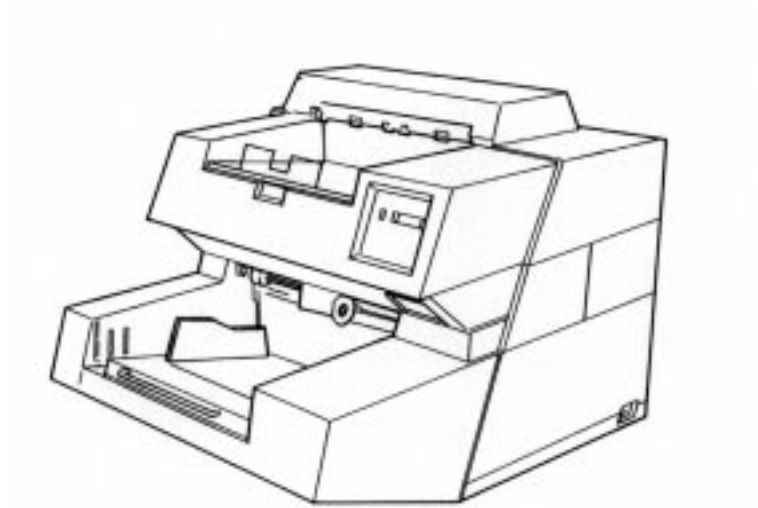

REVISION RECORD		
Edition	Date published	Revised contents
01	January, 1996	First edition
02	April, 1996	Setup mode etc. revised
Specification No. C150-E047-02EN		

The contents of this manual may be revised without prior notice.

All Rights Reserved, Copyright © 1996 FUJITSU LIMITED.

Printed in Japan.

No part of this manual may be reproduced in any form without permission.

Address your comments and inquiries on this manual to:

FUJITSU COMPUTER PRODUCTS OF
AMERICA, INC.
2904 Orchard Parkway, San Jose.
California 95134-2022, U.S.A.
TEL: 1-408-432-6333
FAX: 1-408-432-3908

FUJITSU AUSTRALIA LIMITED
475 Victoria Avenue Chatswood.
N.S.W 2067, AUSTRALIA
TEL: 61-2-410-4555
FAX: 61-2-411-8603

FUJITSU CANADA, INC.
2800 Matheson Blvd. East, Mississauga.
Ontario 4X5, CANADA
TEL: 1-905-602-5454
FAX: 1-905-602-5457

FUJITSU DEUTSCHLAND GmbH.
Frankfurter Ring 211,
8000 Munchen 40, F.R, GERMANY
TEL: 49-89-32378-0
FAX: 49-89-32378-100

FUJITSU ESPANA, S.A
Edificio torre Europa
Paseo de la Castellana 95 Madrid 28046, SPAIN
TEL: 34-1-581-8400
FAX: 34-1-581-8125

FUJITSU EUROPE LTD.
2, Longwalk Road, Stockley Park, Uxbridge
Middlesex, UB11 1AB, U.K
TEL: 44-81-573-4444
FAX: 44-81-573-2643
TLX: 263871

FUJITSU FRANCE S.A.
Batiment Aristote, 17 rue Olof palme
94006 Creteil cedex, FRANCE
TEL: 33-14-513-1616
FAX: 33-14-399-0700

FUJITSU HONG KONG Limited
Room 2521, Sum Hung Kai Centre
30 Harbour Road Wanchal, Hong Kong
TEL: 852-827-5780
FAX: 852-827-4724
TLX: 62667

FUJITSU ITALIA S.p.A.
Via Melchiorre Gioia, No. 8-20124 Milano, ITALY
TEL: 39-2-63651
FAX: 39-2-6572257

FUJITSU NORDIC AB
Kung Hans vag, S-191 76 Sollentuna, SWEDEN
TEL: 46-8-626-6000
FAX: 46-8-626-6711

FUJITSU LIMITED
International Operations
Marunouchi 1-6-1, Chiyoda-ku, Tokyo 100, JAPAN
TEL: (81-3) 3216-3211
FAX: (81-3) 3213-7174
TLX: J22833
Cable: "FUJITSU LIMITED TOKYO"

Preface

This manual provides technical information required to use the original equipment manufacturing (OEM) M3099EX/EH image scanner. The manual is organized as shown below.

Chapter 1 Overview

Chapter 1 provides the scanner features, configuration, and operation.

Chapter 2 Specifications

Chapter 2 provides general, electrical, environmental, physical, and option specifications.

Chapter 3 Interface Specifications

Chapter 3 provides control interface, and video interface specifications.

Chapter 4 Basic Operation

Chapter 4 provides power switch operation, opening/closing the upper transport unit, operator panel arrangement and functions, messages, loading document, and replacement of parts.

Chapter 5 Error Processing and Recovery

Chapter 5 provides how to handles temporary errors and equipment errors and what the operator should do to recovery.

Chapter 6 Document Specification

Chapter 6 provides document specifications (size, type, limitations, grounding color area, drop-out color, and job separation sheet) for the scanner.

Chapter 7 Consumables and Accessories

Chapter 7 provides consumables and accessories.

Chapter 8 Cleaning

Chapter 8 provides cleaning locations and frequencies, cleaning tools, and procedures.

It is recommended that you thoroughly familiarize yourself with the contents of this manual before attempting to use the scanner. Operators in particular must have read Chapter 4, “Basic Operation.”

Conventions

Special information, such as warnings, cautions are indicated as follows:

WARNING

A WARNING indicates that personal injury may result if you do not follow a procedure correctly.

CAUTION

A CAUTION indicates that damage to the scanner may result if you do not follow a procedure correctly.

NOTICE

A NOTICE provides “how-to” tips or suggestions to help you perform a procedure correctly. NOTES are particularly useful for first-time users.

Contents

CHAPTER 1	OVERVIEW	1-1
	Scanner Types	1-1
	Features	1-4
	Configuration	1-5
	Configuration of the scanner	1-5
	Arrangement of units	1-6
	Operation Overview	1-7
	Operation of the mechanism unit	1-7
	Operation of the control unit	1-8
CHAPTER 2	SPECIFICATIONS	2-1
	General	2-1
	Electrical Specifications	2-2
	Environmental Specifications	2-2
	Physical Specifications	2-3
	Option Specifications	2-6
CHAPTER 3	INTERFACE SPECIFICATIONS	3-1
	Control Interface	3-1
	Connection specifications	3-1
	Control interface signals	3-2
	Driver/receiver	3-3
	Timing	3-4
	Video Interface	3-5
	Video interface signals	3-5
	Driver/receiver	3-6
	Data transfer	3-7
	Timing	3-12
	Command and Response	3-14
	Basic command/response sequence	3-14
	Command	3-17

	Responses	3-61
	Command/response correspondence	3-91
	Command/Response Timing Chart	3-93
CHAPTER 4	BASIC OPERATION	4-1
	Power Switch Operation	4-1
	Opening the Upper Transport Unit	4-2
	Closing the Upper Transport Unit	4-2
	Operator Panel Arrangement and Functions	4-3
	Operator panel arrangement	4-3
	Operator panel functions	4-3
	LCD display	4-5
	Button specification and reading mode setting	4-8
	Operation display	4-23
	Buzzer Functions	4-25
	Message List	4-25
	Loading Document	4-26
	Lamp Replacement	4-28
	Roller ASY Replacement	4-33
	Pick Roller Replacement	4-35
	Belt Replacement	4-36
	Pad Replacement	4-38
CHAPTER 5	ERROR PROCESSING AND RECOVERY	5-1
	Device and Operator Actions for Temporary Errors	5-1
	Device and Operator Actions for Equipment Errors	5-4
CHAPTER 6	DOCUMENT SPECIFICATION	6-1
	Document Size	6-1
	Document Quality	6-2
	Document type	6-2
	Ream weight	6-2
	Precautions	6-2
	Document Limitations	6-4
	Areas that must not be perforated	6-4
	Print prohibit areas on the front and back surfaces	6-5

	Grounding Color Area	6-6
	Drop-out Color	6-7
	Print density measurement	6-7
	Drop-out color standards	6-7
	Job Separation Sheet	6-8
	Shape	6-8
	Document type	6-8
CHAPTER 7	CONSUMABLES AND ACCESSORIES	7-1
	Consumables	7-1
	Accessories	7-2
CHAPTER 8	CLEANING	8-1
	Cleaning Locations and Frequencies	8-1
	Cleaning Tools	8-1
	Procedure	8-2
	Cleaning the front-side lamp	8-2
	Cleaning the rollers	8-5
	Cleaning the transport paths	8-6
	Cleaning the glass surface	8-7
	Cleaning the sensors	8-7
APPENDIX A	ENDORSER	A-1
	A1. Specification	A-1
	A2. Panel operation	A-2
	A2.1 How to set endorser ON (or OFF)	A-2
	A2.2 How to set the initial number	A-2
	A2.3 How to set the print number reset condition	A-3
	A2.4 How to reset print number manually	A-3
	A2.5 How to reset print head life counter	A-4
	A2.6 How to test the printing by the operator panel operation	A-4
	A3. Print head handling.....	A-5
	A3.1 Replacing the print head	A-5
	A3.2 Print head position adjustment	A-6

APPENDIX B	SETUP MODE	B-1
	B1. Activating the setup mode	B-1
	B2. Operational transition in the setup mode	B-1
	B3. Contents of the setup mode	B-2
	B3.1 Setting double feed detection	B-3
	B3.2 Setting IPC-2 pre-set mode	B-4
	B3.3 Reset of abrasion counter	B-6
	B3.4 Setting buzzer	B-7
	B3.5 Setting pre-pick	B-7
	B3.6 Adjusting LCD contrast	B-8
	B3.7 Setting pick speed	B-8
	B3.8 Setting initial value of endorser	B-9
	B3.9 Setting reset method of endorser	B-9
	B3.10 Reset of endorser	B-10
	B3.11 Reset of ink counter	B-10
	B3.12 Setting RS232C transfer rate	B-10
	B3.13 Setting picking start time	B-10
	B3.14 Setting picking time	B-11
	B3.15 Setting time-out limit	B-11
	B3.16 Setting hopper time	B-12
	B3.17 Setting heater control	B-13
APPENDIX C	Separation pressure adjustment	C-1
GLOSSARY OF TERMS	GL-1
INDEX	IN-1

Figures

1.1	500 sheets hopper type	1-2
1.2	1000 sheets hopper type	1-3
1.3	Scanner block diagram	1-5
1.4	Arrangement of units	1-6
1.5	Control block diagram	1-8
2.1	Dimensions of 500 sheets hopper type	2-3
2.2	Dimensions of 1000 sheets hopper type	2-4
2.3	Service areas	2-5
3.1	Control interface signal lines	3-2
3.2	Video interface signal lines	3-5
3.3	Scanning direction	3-7
3.4	Scanning data assignment	3-7
3.5	Basic command/response sequence	3-14
3.6	Command/response sequence for initialization	3-84
3.7	Command/response sequence for the read operation (1)	3-86
3.8	Command/response sequence for the read operation (2)	3-88
3.9	Command/response sequence for the read operation (3)	3-90
3.10	CLEAR command sequence	3-94
3.11	CONTROL command sequence (1/4) to (4/4)	3-95
3.12	START command sequence	3-99
3.13	READ command sequence	3-100
3.14	SENSE command sequence	3-101
3.15	RETURN SENSE command sequence	3-102
4.1	Power switch location	4-1
4.2	Operator panel arrangement	4-3
6.1	Document size	6-1
6.2	Areas that must not be perforated	6-4
6.3	Print prohibit areas on the front and back surface	6-5
6.4	Grounding color area	6-6
6.5	Spectrum band	6-7
6.6	Sharp of document	6-8
A.1	Print area	A-1

Tables

1.1	Types of M3099EH	1-1
1.2	Types of M3099EX	1-2
2.1	General scanner specifications	2-1
2.2	Electrical specifications	2-2
2.3	Environmental specifications	2-2
2.4	Physical specifications	2-5
2.5	Option specifications	2-6
3.1	Transferred data length in main scanning (portrait mode)	3-8
3.2	Transferred data length in main scanning (landscape mode)	3-9
3.3	Transferred data length in subscanning (portrait mode)	3-10
3.4	Transferred data length in subscanning (landscape mode) ..	3-11
3.5	Timing specification at binary output	3-13
3.6	Commands	3-17
3.7	Response	3-61
4.1	Button functions	4-4
4.2	LEDs function	4-5
4.3	Buzzer functions	4-25
4.4	Messages	4-25
5.1	Device and operator actions for temporary errors	5-1
5.2	Device and operator actions for equipment errors	5-4
7.1	Consumables	7-1
7.2	Accessories	7-2
8.1	Cleaning locations and frequencies	8-1
A.1	Endorser specifications	A-1

Chapter 1: Overview

Chapter 2: Specifications

Chapter 3: Interface Specifications

Chapter 4: Basic Operation

Chapter 5: Error Processing and Recovery

Chapter 6: Document Specification

Chapter 7: Consumables and Accessories

Chapter 8: Cleaning

Appendix A: Endorser

Appendix B: Setup Mode

Appendix C: Separation pressure adjustment

Glossary of Terms

Index

OVERVIEW

SPECIFICATIONS

INTERFACE
SPECIFICATIONS

BASIC
OPERATION

ERROR
PROCESSING
AND RECOVERY

DOCUMENT
SPECIFICATION

CONSUMABLES
AND
ACCESSORIES

CLEANING

ENDORSER

SETUP MODE

SEPARATION
PRESSURE
ADJUSTMENT

GLOSSARY OF
TERMS

INDEX

OVERVIEW

This chapter provides scanner features, configuration, and operation.

Scanner Types

The M3099EX/EH is a very fast and highly functional image scanner developed for volume filing, using charge-coupled device (CCD) image sensors. This scanner, featuring duplex reading and high-quality image processing, read documents fed by an automatic document feeder (ADF).

Scanner types of M3099EH and M3099EX are shown in Table 1.1 and 1.2. Those types of the scanner is hereinafter referred to as “this scanner”.

Table 1.1 Types of M3099EH

Item \ Type		500 sheets hopper		1000 sheets hopper	
		with IPC2		with IPC2	
		100V	200V	100V	200V
Maximum document size		A4/Letter/Legal			
Scanning	Simplex	80 PPM (A4, 200dpi, portrate)			
	Duplex	60 PPM (A4, 200dpi, portrate)			
Hopper capacity		500 sheets		1000 sheets	
Hight of the Scanner		470 mm		530 mm	
IPC2 (option)		Installed		Installed	
Input voltage		100V	200V	100V	200V
Appearance		Figure 1.1		Figure 1.2	

Table 1.2 Types of M3099EX

Item \ Type	1000 sheets hopper	
	with IPC2	
	100V	200V
Maximum document size	A3/Double letter	
Scanning	Simplex	60 PPM (A4, 200dpi, portrate)
	Duplex	50 PPM (A4, 200dpi, portrate)
Hopper capacity	1000 sheets	
Hight of the Scanner	530 mm	
IPC2 (option)	Installed	
Input voltage	100V	200V
Appearance	Figure 1.2	

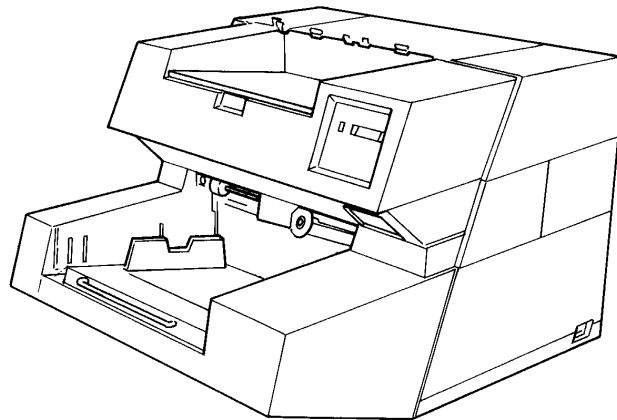

Figure 1.1 500 sheets hopper type

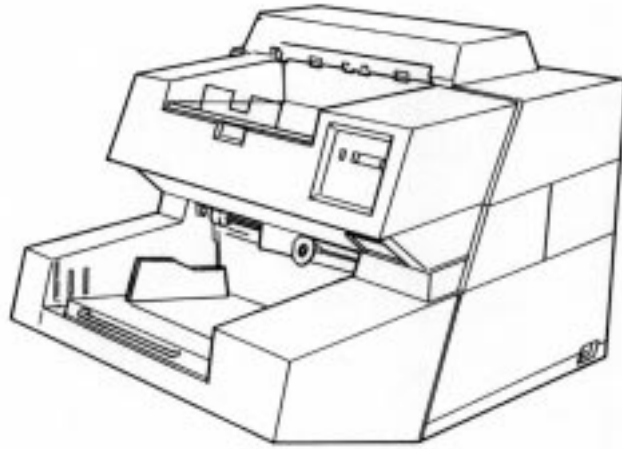

Figure 1.2 1000 sheets hopper type

Features

This scanner has the following features:

Duplex reading

Both sides of a document are read at the same time and their data transferred serially.

Fast reading

This scanner can read documents at high speed: 80 sheets/min (A4, 200dpi) in the simplex reading mode and 60 sheets/min (A4, 200dpi) in the duplex reading mode by M3099EH.

Large-capacity hopper

Up to 1000 sheets (A4, 55 kg) can be loaded on the hopper by the 1000 sheets hopper type.

High-quality image

This scanner uses a compact optical system that provides sharper focus. Furthermore, the use of new LSI chips produces finer images.

New image processing function

The error diffusion feature is provided as standard. Dithering or error diffusion can be applied to those areas judged to be photographs by automatic separation (image processing II option).

Configuration of the scanner

This scanner can be divided into two major sections, mechanism and control unit.

The mechanism unit consists of a hopper to load documents, automatic document feeder, upper and lower transport units to transport documents, a motor drive system, and an optical unit.

The control unit consists of an operator panel, a power supply, a mechanism driver to drive and control the mechanism unit, an image processing control, and an interface control.

Figure 1.3 shows scanner configuration.

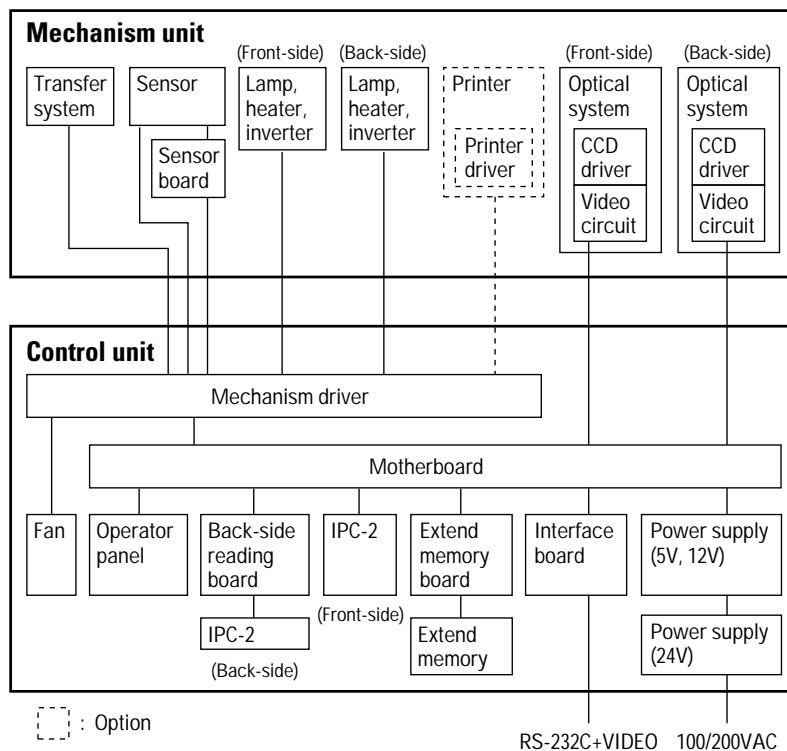

Figure 1.3 Scanner block diagram

Arrangement of units

Figure 1.4 shows arrangement of these units.

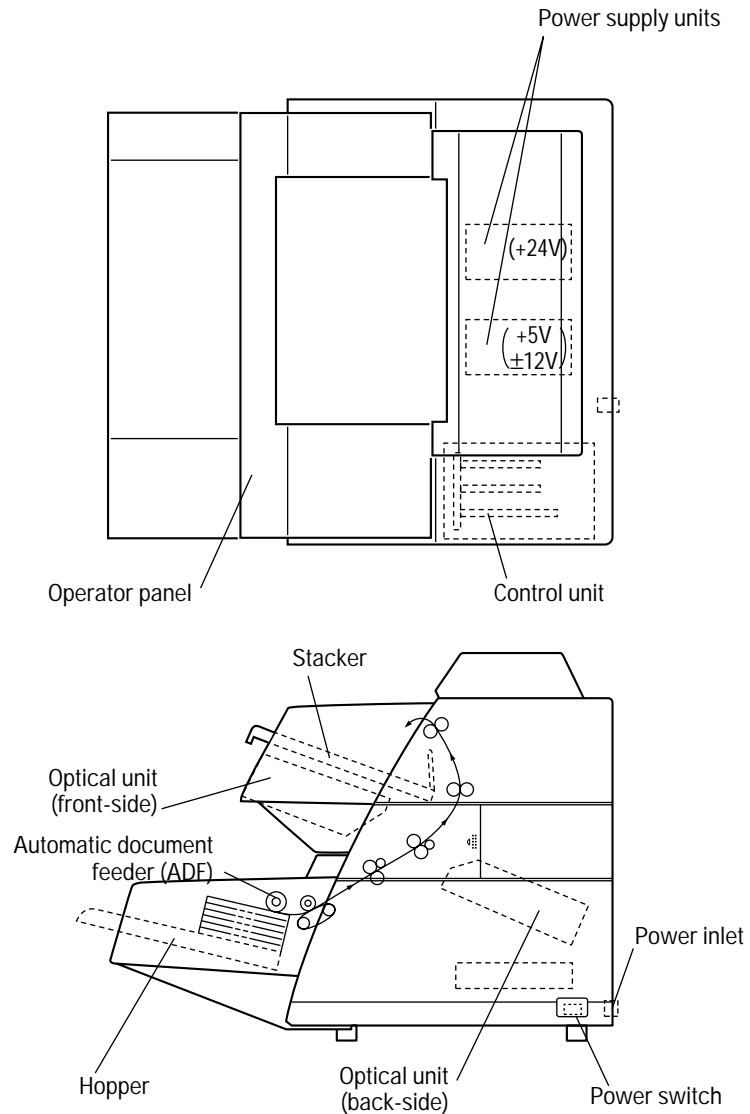

Figure 1.4 Arrangement of units

Operation of the mechanism unit

The mechanism unit consists of two optical units (front and back sides), a hopper and ADF, upper and lower transport units, a motor drive system, and a stacker. Each optical unit consists of a CCD image sensor, a lens, and mirrors. The hopper and ADF feeds stacked documents and the upper and lower transport units transport the documents. The motor drive system drives these units. The stacker stores documents.

When the power is turned on, the lamps are lit and the scanner waits until the light intensities of the lamps become stable. Once the light intensities have become stable, the scanner is ready for a command from the host machine.

A document is picked from the hopper and then ADF feeds a document one by one. The document width is checked and document top is detected.

The documents are counted, fed, and stacked on the stacker.

The lamps illuminate the document, and a lens focuses the images on CCD for photoelectric conversion processing.

Operation of the control unit

The control unit consists of an operator panel, a power supply unit, mechanism driver, an image processing control, and an interface control.

This scanner has the following circuit configuration:

- Operator panel
- Control circuit (MPU)
- Video circuit (front-side/back-side)
- Interface circuit
- Duplex circuit (back-side)
- Motor driver circuit (including a stepper motor, a clutch driver)
- Power supply unit
- Image processing circuit (IPC II option)
- Memory board

Figure 1.5 shows control block diagram.

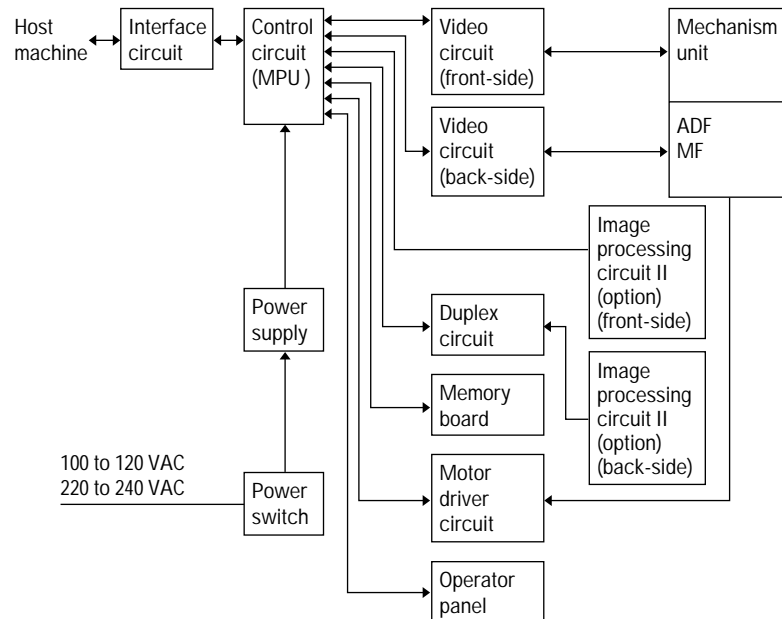

Figure 1.5 Control block diagram

Main control unit

This scanner is controlled by a 80C186 MPU. This scanner consists of a ROM as a program area, internal registers, an external RAM as a work area, gate arrays for the MPU peripheral and video circuits, dither processing and γ conversion RAMs, and error diffusion.

Interface control

RS-232C and video interface

RS-232C interface

The RS-232C interface consists of an ACIA(8251) and driver-receiver ICs (145406).

Video interface

This scanner processes a document by the 256-step gray scale. Images are processed in a way specified by the interface or the operator panel and transferred serially in eight-bit units. Eight-bit data has $\overline{V0}$ at the left end and $\overline{V7}$ at the right end and strobed by VCL.

\overline{HGATE} ensures the validity of data in the main scanning and \overline{VGATE} for the subscanning.

The scanner status is basically reported by the RS-232C interface. An equipment error is reported to the host computer by a \overline{FAIL} signal in case that RS-232C communication failed. See Chapter 3 for detailed specifications of the interfaces.

Resolution

The basic resolution of this scanner is 200dpi. The resolution can be changed to 240, 300, or 400dpi from the host computer or the operator panel.

The resolution in the subscanning direction is achieved by changing the document transport speed.

When the image processing circuit II (IPC II) option is installed, the linear density is changed by setting the parameter to its internal circuit.

Video amplifier and driver section

This section consists of a CCD drive circuit, a video amplifier circuit, a white-black level correction circuit, sensors, and also control circuits for the stepping motor, heater, and lamps.

Image processing section

The IPC II option enables the following image processing functions:

- Automatic separation function (to read documents containing characters and photographs)
- Inversion function
- Mirror image output function
- Outline extraction function
- Overlay function
- Smoothing, filtering, and noise removing

Power supplies

This scanner has two power supplies. Their output voltages are as follows:

Power supply 1

- +5V: For logic circuits
- ± 12 V: For video amplifiers

Power supply 2

- 24V: For lamp, heater, and stepping motor drive

SPECIFICATIONS

This chapter provides general, electrical, environmental, physical, and option specifications.

General

Table 2.1 list general scanner specifications.

Table 2.1 General scanner specifications

Item		Type	M3099EH		M3099EX
			500 sheets hopper	1000 sheets hopper	1000 sheets hopper
Sensor		CCD image sensor			
Scanning method		ADF (automatic document feeder) & MF (manual feeder)			
Document size	MAX.	216 × 356 mm (A4/Letter/Legal)		297 × 432 mm (A3/Double letter)	
	MIN.	76 × 63 mm (3" × 2.5")			
Light source		Green fluorescent lamp			
Hopper/stacker capacity (64 g/m ²)		MAX. 500 sheets	MAX. 1000 sheets	MAX. 1000 sheets	
Gray scale (internal)		256 steps			
Output video		Binary/Halftone (64 levels)			
Scanning speed (A4, 200dpi, portrait)	Simplex	80 PPM		60 PPM	
	Duplex	60 PPM		50 PPM	
Output density		Standard: 400, 300, 240, 200dpi (Horizontal scanning and vertical scanning are independent.) If the image processing II (IPC2) is installed: 50 to 400 dpi (Horizontal scanning and vertical scanning are independent.)			
Binarization and halftone function		Standard: Fixed binarization, dither, error diffusion method. If the image processing II (IPC2) is installed: Automatic separation, image emphasis, outline extraction, mirror image, inversion, simplified DTC. Dynamic threshold, smoothing, filtering, noise removing.			
Interface		RS-232C (Control signal) + Local (Video signal)			

Electrical Specifications

Table 2.2 lists electrical specifications.

Table 2.2 Electrical specifications

Item		Specification
Input power	Voltage	100 to 120 VAC/220 to 240 VAC \pm 10%
	Phase	Single-phase
	Frequency	50/60 Hz +2%, -4%
Power consumption		0.25 kVA or less
Rush current		30 A or less
Momentary power failure		100%, 0.5 Hz
Leakage current		3.5 mA or less
Dielectric strength		DC 1.8 KV for one minute or more (between FG and AC lines)
AC line noise		Voltage 1.2 KV pulse duration 5 μ s
Heat capacity		110 Kcal/H (440 BTU/H)

Environmental Specifications

Table 2.3 lists environmental specifications.

Table 2.3 Environmental specifications

Item		Specification	
Ambient conditions	Device status	Operating	Not operating
	Temperature	5 to 35°C	-20 to 60°C
	Humidity	20 to 80% (no condensation)	8 to 95% (no condensation)
Shock		0.2 G less	0.4 G or less
Stability		5° or less	10° or less
Acoustic noise		59 dBA or less (ISO 7779)	50 dBA or less (ISO 7779)
ESD		8 KV or more	

Physical Specifications

Figure 2.1 to Figure 2.2 show the scanner dimensions, Figure 2.3 shows scanner service areas. Table 2.4 lists physical specifications.

SPECIFICATIONS

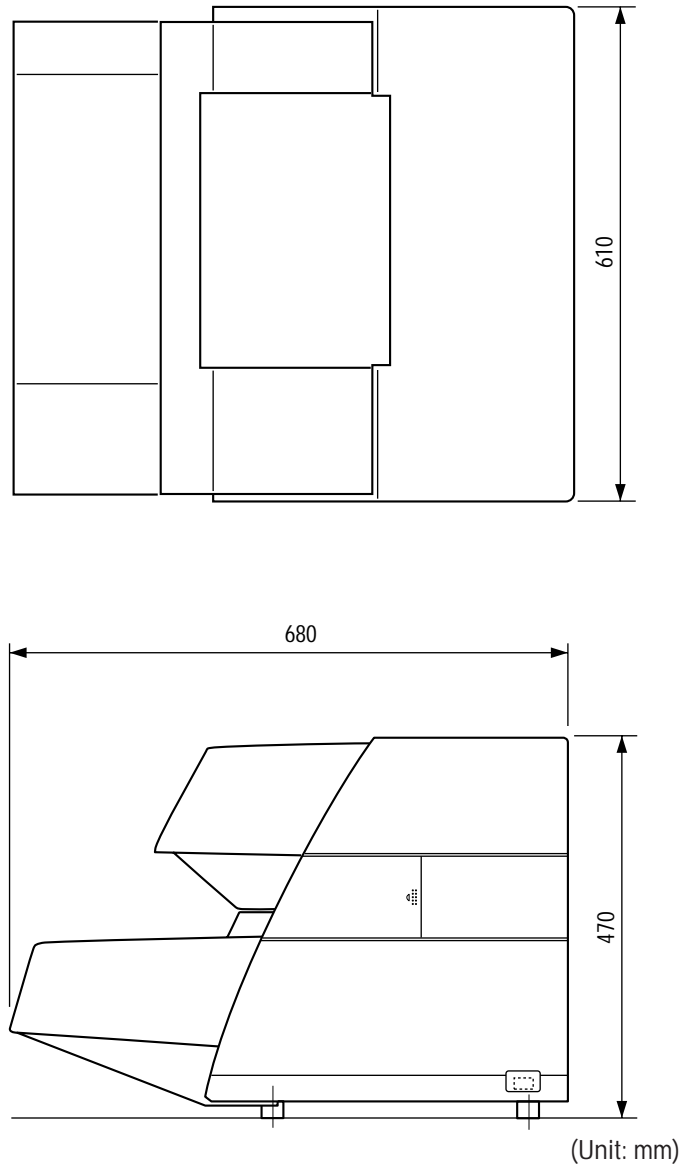
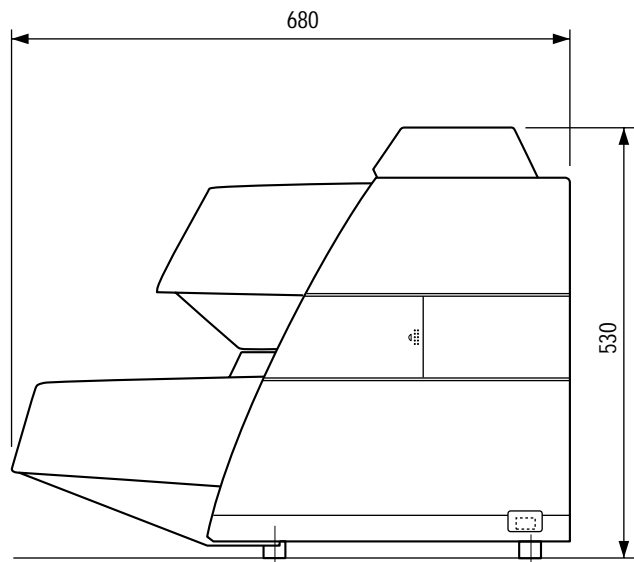
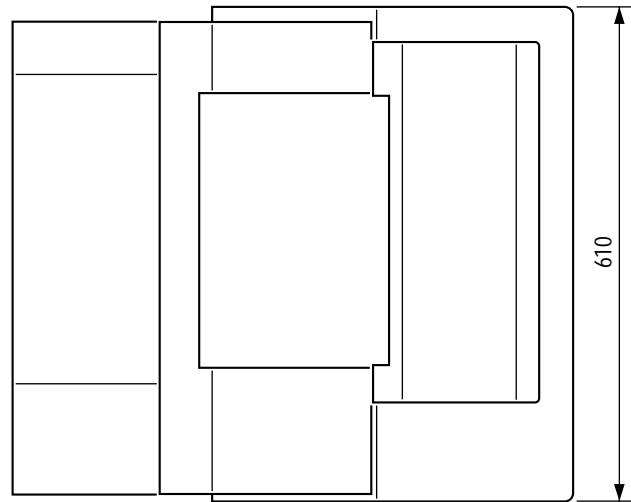

Figure 2.1 Dimensions of 500 sheets hopper type



(Unit: mm)

Figure 2.2 Dimensions of 1000 sheets hopper type

Table 2.4 Physical specifications

Item \ Type		500 sheets hopper type	1000 sheets hopper type
		Dimensions	
	Width	610 mm	610 mm
	Depth	680 mm	680 mm
	Height	470 mm	530 mm
Weight		55kg	65kg

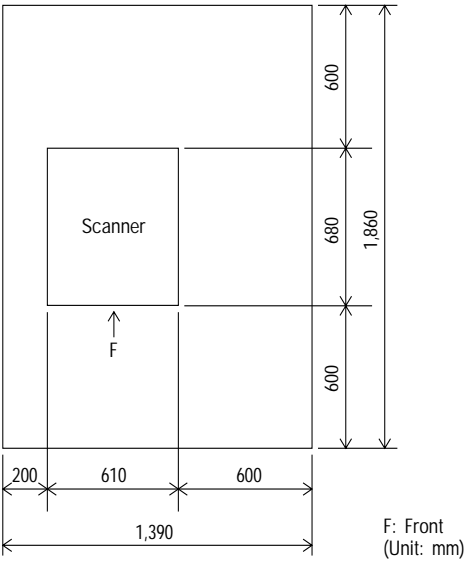

Figure 2.3 Service areas

Option Specifications

Table 2.5 lists the scanner option specifications.

Table 2.5 Option specifications

Item	Specification	Detail	Remark
Endorser	CA01023-D004	Ink-jet back-side print max. 20 characters	

INTERFACE SPECIFICATIONS

Control Interface

This section describes the control interface between the host computer and the scanner. For details of the interface, refer to the EIA RS-232C standard.

Connection specifications

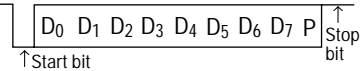
Item	Specification	Remark
Transmission system	Half-duplex	
Synchronization system	Start-stop	
Data length	8 bits	
Stop bit	1 bit	
Data check	Odd parity check 	
Data transfer rate	1200, 2400, 4800, 9600 bps	Set by EEPROM on Interface PCA Default: 4800 bps
Maximum connection	5 m (16 ft.)	
Standard	EIA RS-232C	

Control interface signals

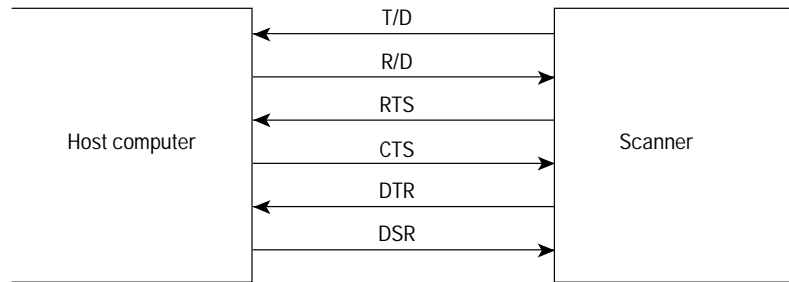

Figure 3.1 Control interface signal lines

Send data (T/D)

This signal is the response and acknowledge for the command sent on the R/D line.

Received data (R/D)

This line sends the command and acknowledge for a response.

Send request (RTS)

This line sends a request to send a response and acknowledge for the command.

Transmission enabled (CTS)

This line sends an acceptance of RTS signal.

Terminal ready (DTR)

This signal indicates that the scanner is ready for transmission and reception.

This signal is set to off when the scanner is turned off, when the scanner is initially checked after power on.

Controller ready (DSR)

This signal indicates that the host computer is ready for transmission and reception.

Driver/receiver

- Driver: SN75188 or equivalent
- Receiver: SN75189 or equivalent

To determine the threshold level of the signal at the receiver, the following circuit must be connected to the response control pins.

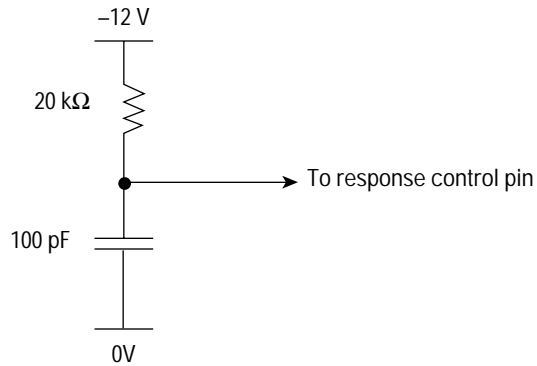

Timing

Scanner → Host computer (At transmission)

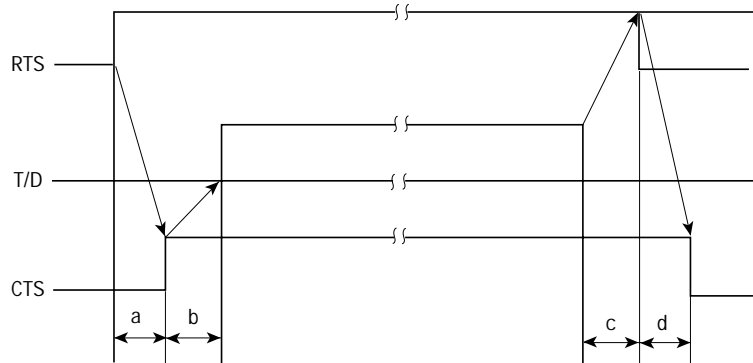

- a: +0 ms
- b: +0 to 5 ms
- c: +0 to 10 ms (more than 1 word length)
- d: +0 ms

Video Interface

This section describes the video interface, which transfers the scanning data from the scanner to the host computer.

Video interface signals

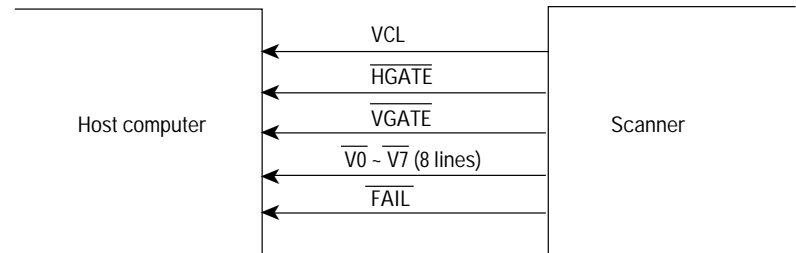

Figure 3.2 Video interface signal lines

(1) VCL

This signal is a sampling clock for the video data $\overline{\text{V0}}$ to $\overline{\text{V7}}$.

(2) $\overline{\text{HGATE}}$

This signal indicates that the main scanning video data is valid.

(3) $\overline{\text{VGATE}}$

This signal indicates that the subscanning video data is valid.

(4) $\overline{\text{V0}}$ to $\overline{\text{V7}}$

These signal lines carry the scanning video data. Logical “0” indicates a black dot.

(5) $\overline{\text{FAIL}}$

This signal indicates that a device error (MPU ROM/RAM error) has occurred in the scanner.

Driver/receiver

Driver/receiver for standard connector and $\mu 3096A21$ connector.

(1) VCL

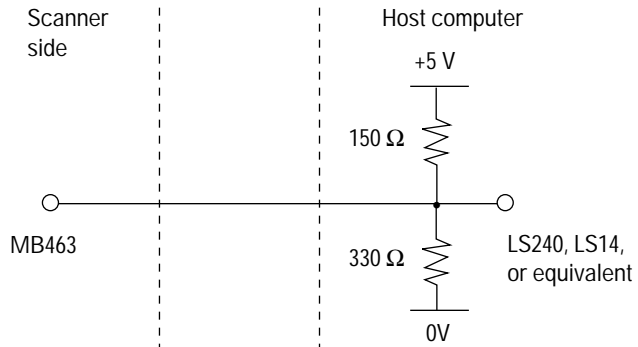

(2) $\overline{V0}$ to $\overline{V7}$

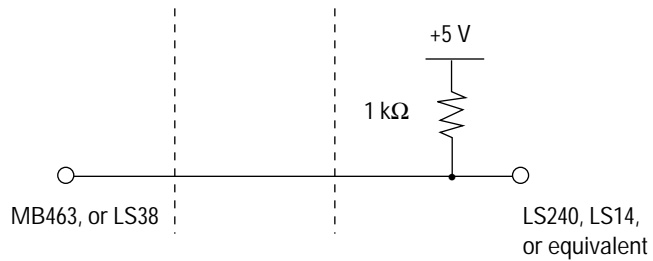

\overline{HGATE} , \overline{VGATE} , \overline{FAIL}

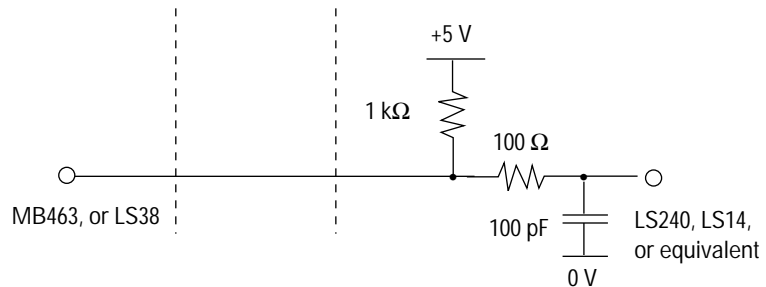

Data transfer

Scanning video data is transferred to the host computer through video data signal line $\overline{V0}$ to $\overline{V7}$ in parallel synchronized with VCL.

Transfer sequence

Scanning is performed as shown in Figure 3.3, and the scanning data is assigned to the video data signal as shown in Figure 3.4. The scanning data is sent to the host computer in order of scanning.

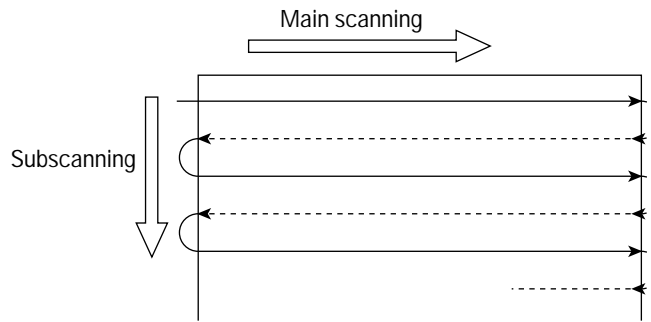
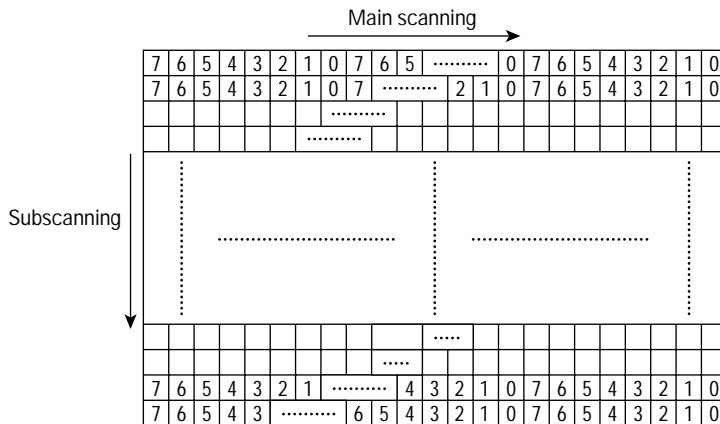

Figure 3.3 Scanning direction



Notes:

1. “0” to “7” correspond to the video data signal $\overline{V0}$ to $\overline{V7}$ respectively.
2. The most significant bit (MSB) of each video data signal is read first.

Figure 3.4 Scanning data assignment

Effect in main scanning

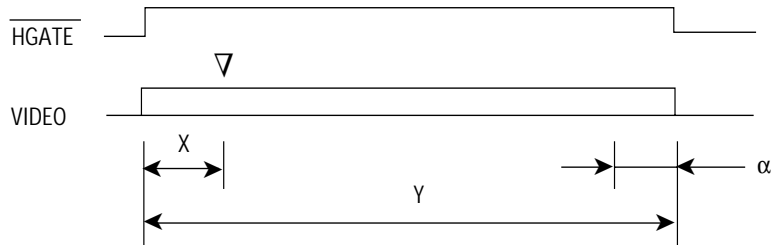

The values of X, Y, and α are shown in Tables 3.1 and 3.2.

▽ : Reference point of main scanning.

Table 3.1 Transferred data length in main scanning (portrait mode)

Item	Document size		Double-letter*	A3 *	B4 *	A4	B5	A5	LEGAL	LETTER
400 dpi	Offset dot	X	12±12	←	←	←	←	←	←	←
	Transferred data	Y	4400	4864	4096	3456	3456	2304	3456	3456
	Dummy dots	α	-	-	-	-	-	-	-	-
300 dpi	Offset dot	X	9±9	←	←	←	←	←	←	←
	Transferred data	Y	3304	3648	3072	2592	2592	1728	2592	2592
	Dummy dots	α	-	-	-	-	-	-	-	-
240 dpi	Offset dot	X	8±8	←	←	←	←	←	←	←
	Transferred data	Y	2640	2920	2464	2080	2080	1384	2080	2080
	Dummy dots	α	-	-	-	-	-	-	-	-
200 dpi	Offset dot	X	6±6	←	←	←	←	←	←	←
	Transferred data	Y	2200	2432	2048	1728	1728	1152	1728	1728
	Dummy dots	α	-	-	-	-	-	-	-	-

Note : 1. Data of dummy dots are sent as white.

(Unit : lines)

2. Document size with * mark is available onl for M3099EX.

Table 3.2 Transferred data length in main scanning (landscape mode)

Item	Document size		Double-letter	A3	B4	A4 *	B5 *	A5	LEGAL	LETTER *
400 dpi	Offset dot	X				12±12	←	←	-	12±12
	Transferred data	Y				4680	4080	3312	-	4400
	Dummy dots	α				-	-	-	-	-
300 dpi	Offset dot	X				9±9	←	←	-	9±9
	Transferred data	Y				3512	3040	2480	-	3304
	Dummy dots	α				-	-	-	-	-
240 dpi	Offset dot	X				8±8	←	←	-	8±8
	Transferred data	Y				2808	2432	1984	-	2640
	Dummy dots	α				-	-	-	-	-
200 dpi	Offset dot	X				6±6	←	←	-	6±6
	Transferred data	Y				2344	2024	1656	-	2200
	Dummy dots	α				-	-	-	-	-

Note : 1. Data of dummy dots are sent as white.
 2. Document size with * mark is available onl for M3099EX. (Unit : lines)

Effect in subscanning

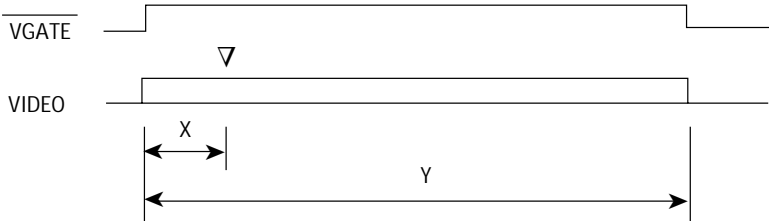

The values of X and Y are shown in Tables 3.3 and 3.4.

∇ : Reference point of subscanning.

Table 3.3 Transferred data length in subscanning (portrait mode)

Item	Document size		Double-letter*	A3 *	B4 *	A4	B5	A5	LEGAL	LETTER
400 dpi	Offset dot	X	32	←	←	←	←	←	←	←
	Transferred data	Y	6912	6614	5732	4677	4048	3307	5600	4400
300 dpi	Offset dot	X	24	←	←	←	←	←	←	←
	Transferred data	Y	5184	4961	4300	3508	3036	2480	4200	3300
240 dpi	Offset dot	X	20	←	←	←	←	←	←	←
	Transferred data	Y	4160	3969	3440	2806	2429	1984	3360	2640
200 dpi	Offset dot	X	16	←	←	←	←	←	←	←
	Transferred data	Y	3456	3307	2886	2339	2024	1654	2800	2200

Note : 1. Document size with * mark is available only for M3099EX.
 2. The document size (VGATE) is set to off when the edge of the document passes the scan position.

(Unit : lines)

Table 3.4 Transferred data length in subscanning (landscape mode)

Item	Document size		Double-letter	A3	B4	A4 *	B5 *	A5	LEGAL	LETTER *
400 dpi	Offset dot	X				32	←	←	-	32
	Transferred data	Y				3456	3456	2304	-	3456
	Dummy dots	α								
300 dpi	Offset dot	X				24	←	←	-	24
	Transferred data	Y				2592	2592	1728	-	2592
	Dummy dots	α								
240 dpi	Offset dot	X				20	←	←	-	20
	Transferred data	Y				2080	2080	1384	-	2080
	Dummy dots	α								
200 dpi	Offset dot	X				16	←	←	-	16
	Transferred data	Y				1728	1728	1152	-	1728
	Dummy dots	α								

Note : 1. Document size with * mark is available only for M3099EX. (Unit : lines)
 2. The document size (VGATE) is set to off when the edge of the document passes the scan position.

Timing

VCL and $\overline{V0}$ to $\overline{V7}$

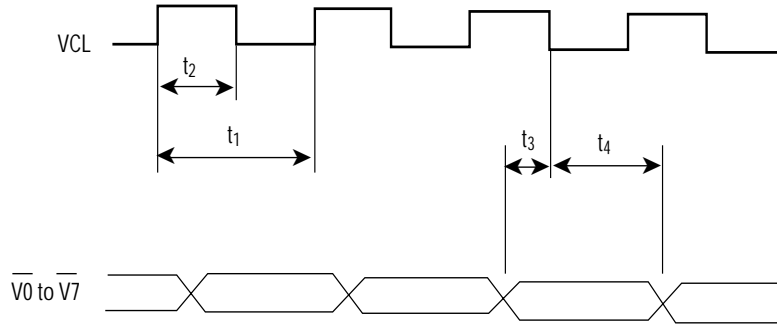

VCL and \overline{HGATE}

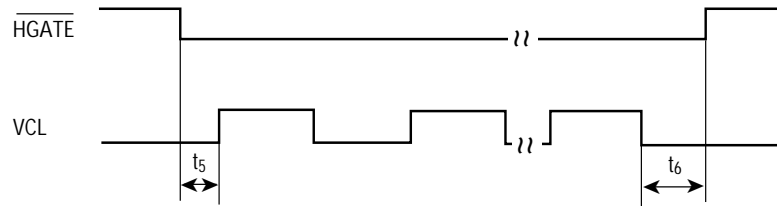

Note : VCL is not output when \overline{HGATE} is off.

\overline{HGATE} and \overline{VGATE}

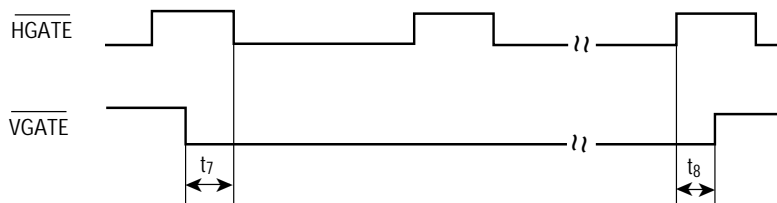

Note : \overline{HGATE} is always output.

The values of t_1 to t_8 is shown in Table 3.5.

Table 3.5 Timing specification at binary output

[Standard transfer : front-side]

	MIN	TYP	MAX
t1	700	800	900
t2	500	600	700
t3	500	600	700
t4	100	200	300
t5	100	200	300
t6	100	200	300
t7	100	200	300
t8	2000	*1	

Unit : ns

[Fast transfer : back-side]

	MIN	TYP	MAX
t1	300	400	500
t2	100	200	300
t3	100	200	300
t4	100	200	300
t5	100	200	300
t6	100	200	300
t7	100	200	300
t8	2000	*1	

Unit : ns

Notes: 1. Timing marked with * varies according to the scanning area.

Command and Response

Basic command/response sequence

Data is transmitted between the host computer and the image scanner in the form of commands and responses. Figure 3.5 shows the basic command/response sequence.

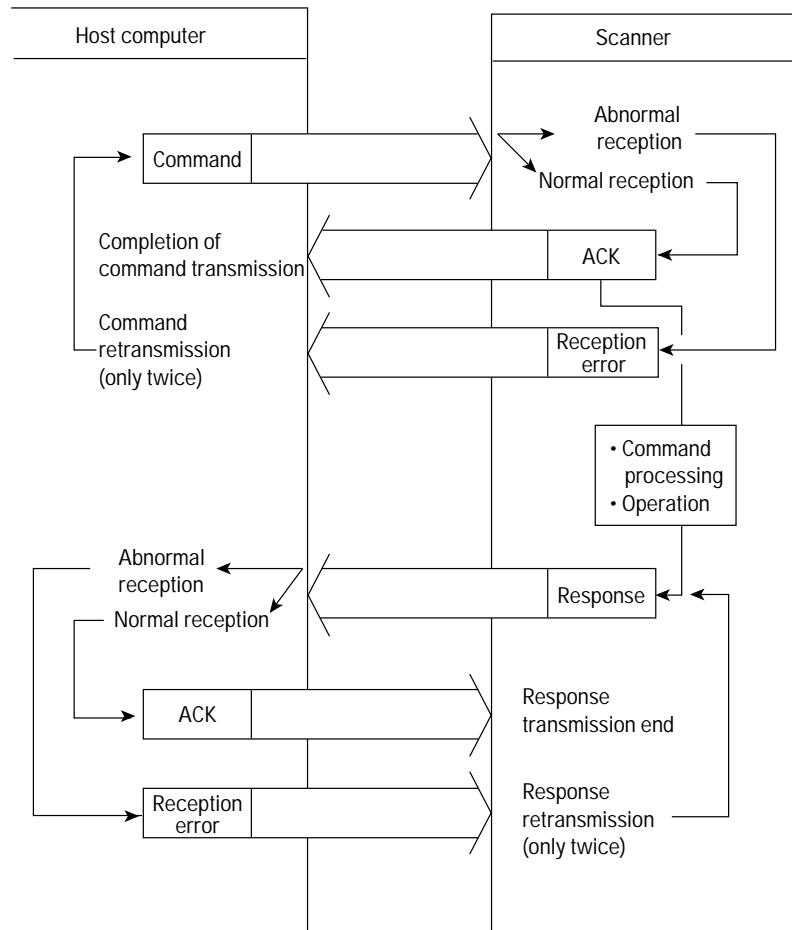

Figure 3.5 Basic command/response sequence

Notes:

1. Abnormal reception means that a parity error, framing error, overrun error, or count error has occurred.
2. Command or response transmission is retried only twice.
3. Upon reception, a command or response is checked for transmission errors. When the check result has no problem, ACK is returned immediately to the originating source. When the check result has problem, data other than ACK is returned after all data has been received.

Response data		Details	Code (Hex)
ACK (Acknowledge)		A command or response has been received without an error.	X 'FF'
Reception error	Parity error	A parity error has been detected in received data.	X'80'
	Framing error Overrun error	A framing error or an overrun error has been detected in received data.	X '81'
	Count error	The byte count for the command or response does not match the number of bytes transferred.	X '82'

4. The originating source of the command/response monitors the response from the receiving side. ACK indicates that command/response transmission is completed.

Reception error causes the command/response to be transmitted again. The transmission is returned only twice. After that, the scanner waits for a new command.

5. Response data such as ACK must be retried to the originating source within 0.5 second.
6. The interval between words in the data stream must be no more than 10 ms.

Command/response format

The command/response format is as follows.

CNT	CMD/RPS	TEXT	Additional field
-----	---------	------	------------------

CNT (count) field

The total number of bytes in the command/response to be transmitted is represented.

CMD/RPS field

A command or response code is indicated.

TEXT field

Additional information for a command/response, called control or device information, is indicated.

Additional field

In some commands, additional field exists next to TEXT field.

Command

Commands sent from the host computer to the scanner are as listed in Table 3.6. The scanner commands are as follows:

Table 3.6 Commands

Command name	Command code	Details
CLEAR	44	This command initializes the scanner. This command can be issued at any time.
CONTROL	58	This command sets the operation mode of the scanner and the operation mode in the main window.
IMAGE CONTROL	5A	This command sets the image processing mode of the scanner. (*1)
PRINT CONTROL	5E	This command instructs how to print to the manuscript. (*2)
START	53	This command reports the size of a document to be read.
READ	54	This command starts reading. The scanner starts reading according to the operation mode set previously.
SENSE	41	This command requests a status report.
RETURN SENSE	42	This command requests a status report on the return of the flatbed read.
IMAGE MODE SENSE	43	This command requests a status report of the image processing mode of each main window and the number of pixels (in units of a byte) per line in the X- direction.
SEND DITHER 1	46	This command transfers the dither and overlay patterns.
SEND DITHER 2	47	This command transfers the dither, γ curve, or overlay patterns.
SEND DATA	48	Transfers print pattern and data items. (*2)
INQUIRY	40	This command requests a device information report.

*1: This command can be transmitted only when the image processing option is connected.

*2: This command can be transmitted only when the endorser option is connected.

Command name	1	2	3	4 or later
CLEAR	X'03'	X'44'	CLEAR command details	_____
CONTROL	X'0X'	X'58'	Control register start number.	Control register
IMAGE CONTROL	X'0X'	X'5A'	Image control register start number.	Image control register
PRINT CONTROL	X'0B'	X'5E'	Print information I	Byte 4: Print information II Byte 5 and 6: Print position X Byte 7 and 8: Print position Y Byte 9: Number counter method Byte 10 and 11: Number initial value
START	X'02'	X'53'	_____	_____
READ	X'02'	X'54'	_____	_____
SENSE	X'02'	X'41'	_____	_____
RETURN SENSE	X'02'	X'42'	_____	_____
IMAGE MODE SENSE	X'03'	X'43'	IMAGE MODE SENSE command details	_____
INQUIRY	X'02'	X'40'	_____	_____
SEND DITHER 1	X'43'	X'46'	Dither or overlay pattern number.	Dither or overlay pattern 64 bytes or more
SEND DITHER 2	X'05'	X'47'	X'00'	Byte 4 and 5: CNT Byte 6: Pattern ID Byte 7 or later: Dither, overlay or γ curve data
SEND DATA	X'XX'	X'48'	Print information III	Printing data

CLEAR command

This command initializes the scanner and can be issued at any time.

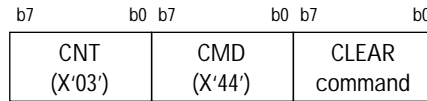

CLEAR command details

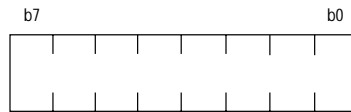

- 00: POWER ON CLEAR
This command resets the system to the power-on status.
- 01: Control register clear
This command initializes the operation mode, image processing mode, and subwindow mode. (*1)
- 10: Reading stop
This command stops operation during (VGATE OFF, return) and ejects any documents remaining in the ADF.
If this command is received after the front-side is reading ends, the scanner is placed in wait state.

Note: "Ready" is the response when this command ends normally.

*1: If a CONTROL REGISTER CLEAR command is issued after the READ command is sent to the scanner but before the Read Complete is received from the scanner, a command sequence error occurs.

CONTROL command

This command sets the scanner to the operation mode.

Selection of control register

This scanner has an additional function to select control register, using bits 6 and 7 of byte 3 of the CONTROL command supported by the existing devices (M3093E, M3096E+, and M3097E).

- Front-side reading or front-side and back-side reading control register specification
- Back-side reading control register specification
- Extended control register specification

The registers are specified as follows:

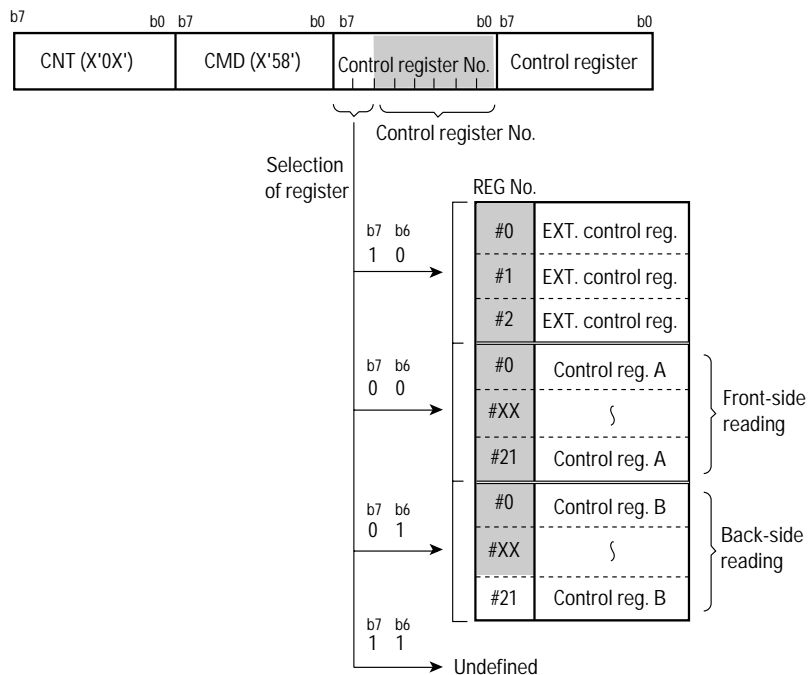

Hereafter, a control register for front-side reading (compatible with the existing devices) is called control register A. A control register for back-side reading is called control register B.

Extend control register

Extend control register #0

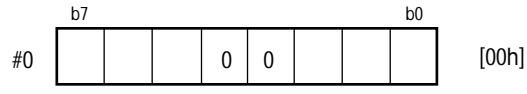

Transfer mode (back-side) (*1)

This function specifies how image data in the back-side memory should be transferred.

- 000: Transfer mode 0
- 001: Transfer mode 1
- 010: Transfer mode 2
- 011: Transfer mode 3
- 1xx: Reserved

Reading mode specification

- 0xx: Set from the operator panel
- 100: Front-side reading
- 11x: Duplex reading

*1: See the 3-23 page.

Extend control register #1

This register is not supported.

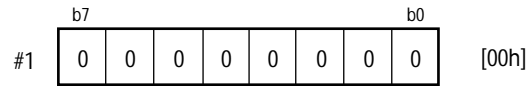

X'00' is set when the power is turned on or when a CLEAR command is issued for initialization.

[Data transfer mode]

Transfer mode	Front-side	Back-side	Ext
Mode 0			
Mode 1	Not supported		Mirror
Mode 2	Not supported		
Mode 3	Not supported		Mirror

▼ : Scanning reference position

INTERFACE
SPECIFICATIONS

Extend control register #2

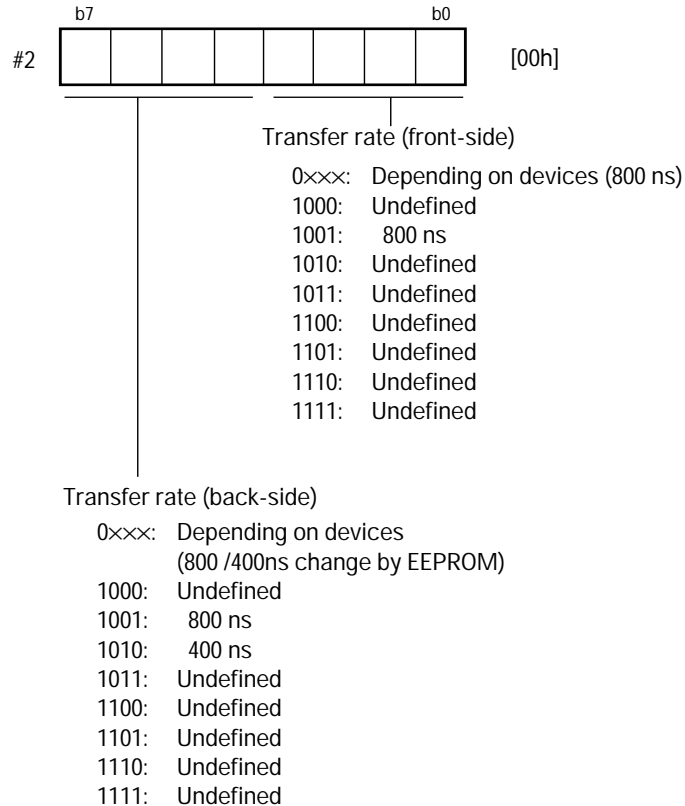

- This register specifies the front-side and back-side image data transfer rates.

Extend control register #3

This register is not supported.

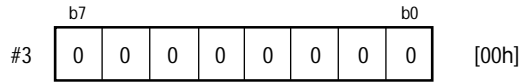

X'00' is set when the power is turned on or when a CLEAR command is issued for initialization

Control register A#0

X'00' is set when the power is turned on or when a CLEAR command is issued for initialization.

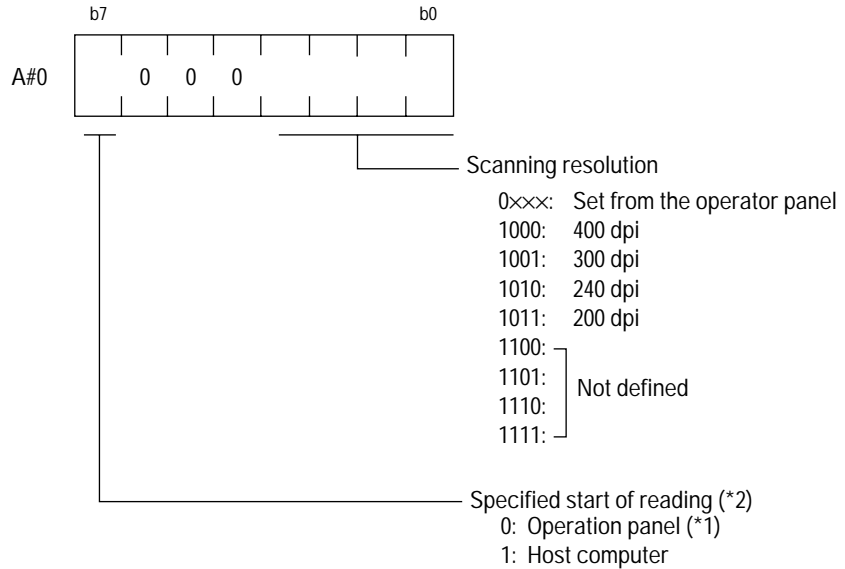

*1: When the start of reading is specified from the operator panel, the Ready lamp lights at reception of a START command.

*2 If the manual mode is selected at the operator panel, reading actually starts when a document is loaded on the scanner.

Control register B#0



Control register A#1

Control register B#1

X'00' is set when the power is turned on or when a CLEAR command is issued for initialization.

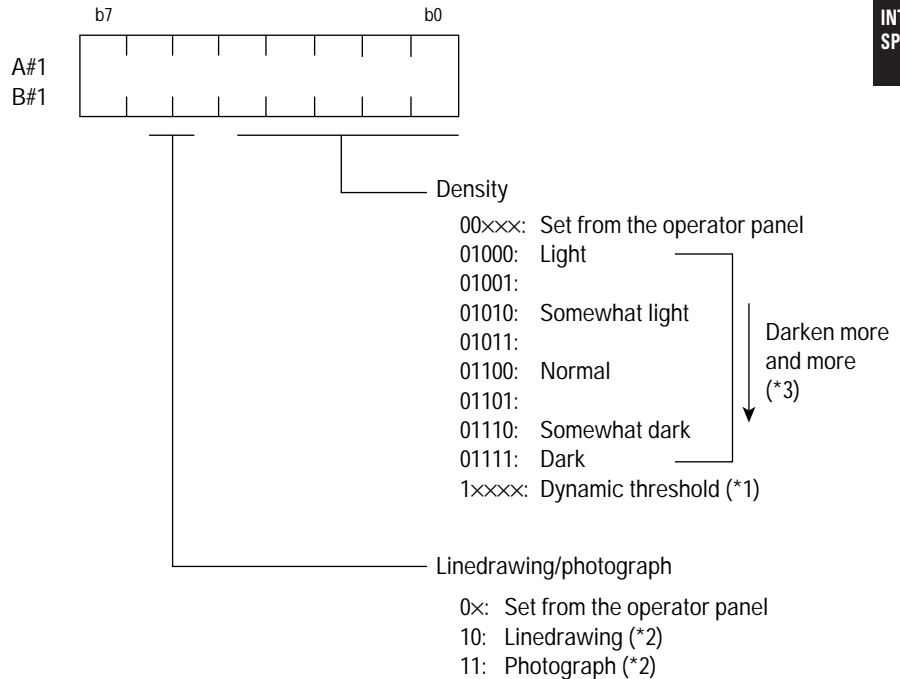

*1: This function is valid for image processing circuit (IPC II) option.
 When the IPC II option is installed and these bits indicate IXXXX, the scanner applies the DTC function, and the function of the image control register are not operated.

*2 The scanning speed of ADF (sheets/min) in linedrawing mode is different from that of photograph mode.

*3: When the control register #19, bit 0 is "0", eight types density are selectable by control register #1, bit 3 to 0.
 And when the control register #19, bit 0 is "1", 256 types density are selectable by the control register #20.

Control register A#2

Control register B#2

X'00' is set when power is turned on or when a CLEAR command issued for initialization.

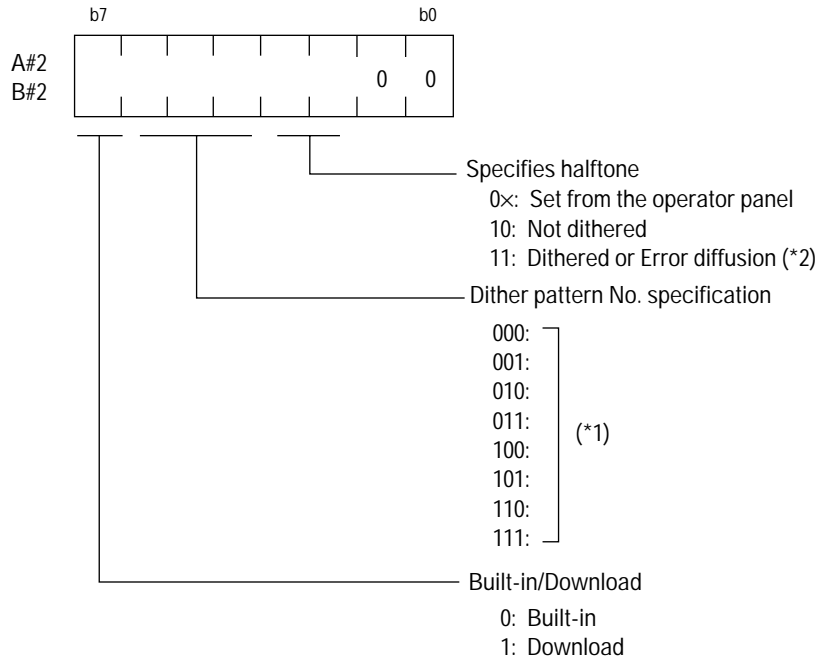

- *1:
- When the built-in pattern is used, the density information shown in the control register #1 is valid.
 - Four patterns (000 to 011) are valid when the built-in pattern is selected.
 - When the download pattern is used, the density information shown in control register #1 is invalid.
 - Eight patterns (000 to 111) is valid when the download pattern is

*2: Dithered or Error diffusion are selected by control register #19.

Control register A#3

Control register B#3

X'AG' is set when power is turned on or when a CLEAR command is issued for initialization.

- This register is valid when the IPC II option is installed.

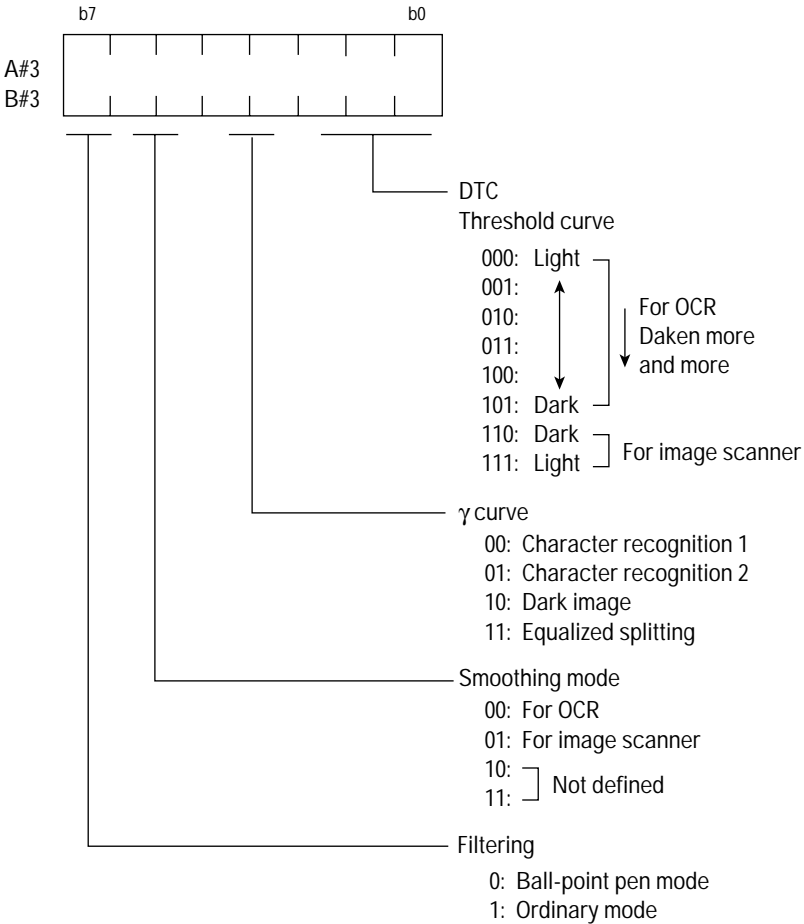

Control register A#4

Control register B#4

X'20' is set when power is turned on or when a CLEAR command is issued for initialization.

- This register is valid when the IPC II option is installed.

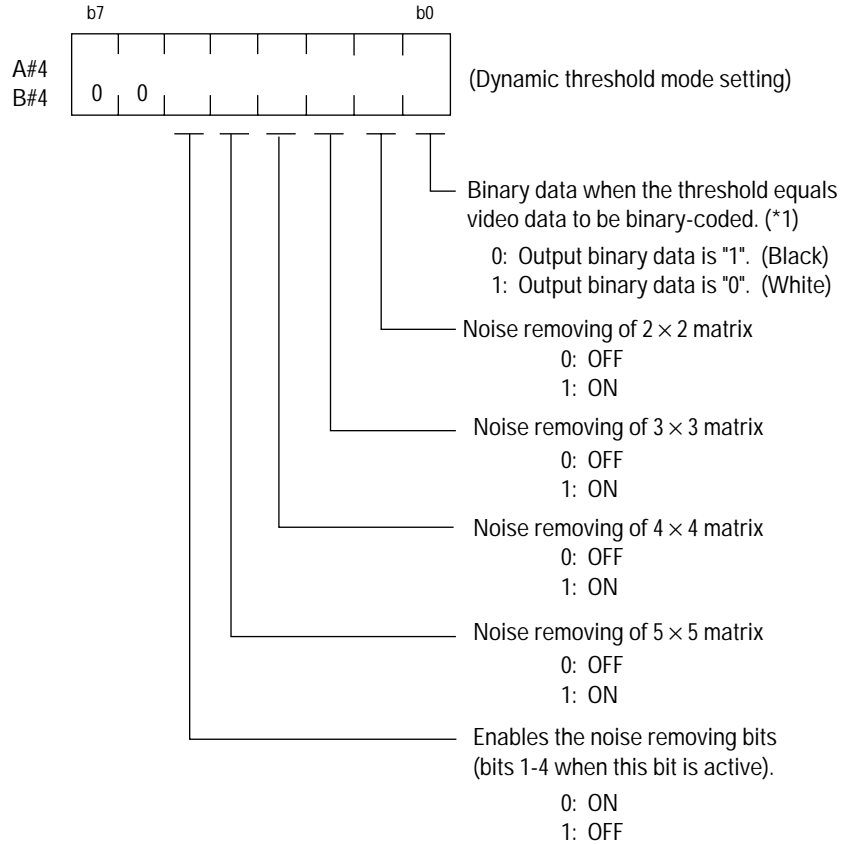

*1: When this bit is "0", the output video data is black if the gradation of the video data is equal to or larger than threshold. When this bit is "1", the output video data is white if the gradation of video data is equal to or larger than threshold.

Control register A#5

X'00' is set when the power is turned on or when a CLEAR command is issued for initialization. Default document size depends on the EEPROM setting.

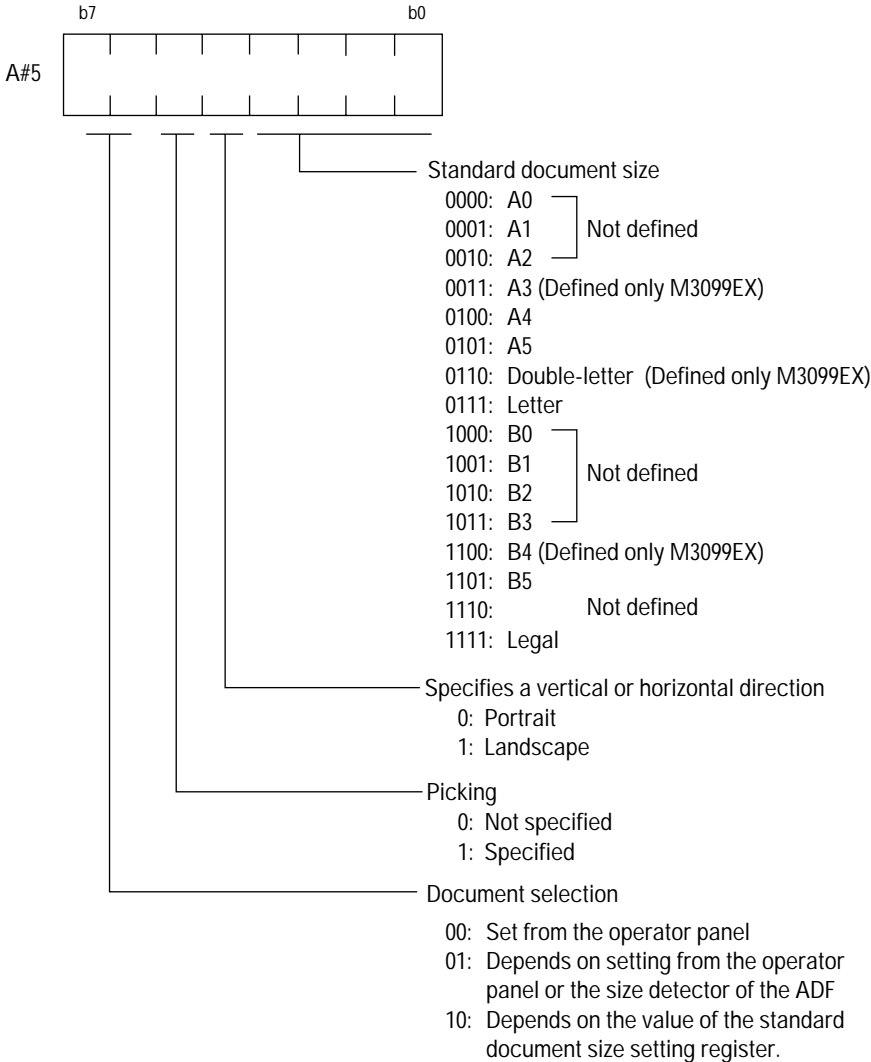

Control register B#5

X'00' is set when the power is turned on or when a CLEAR command is issued for initialization.

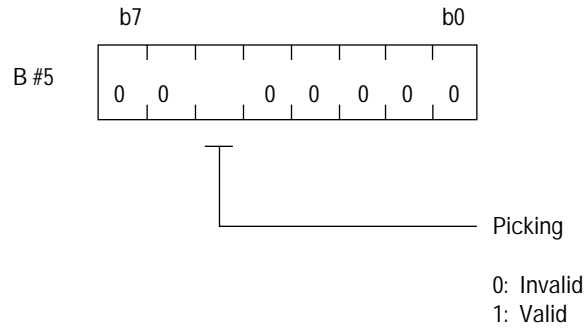

Control register A#6 to #9

Control register B#6 to #9

Not specified for this scanner.

Control register A#10 to #17

Control register B#10 to #17

Picking area (main window) setting register

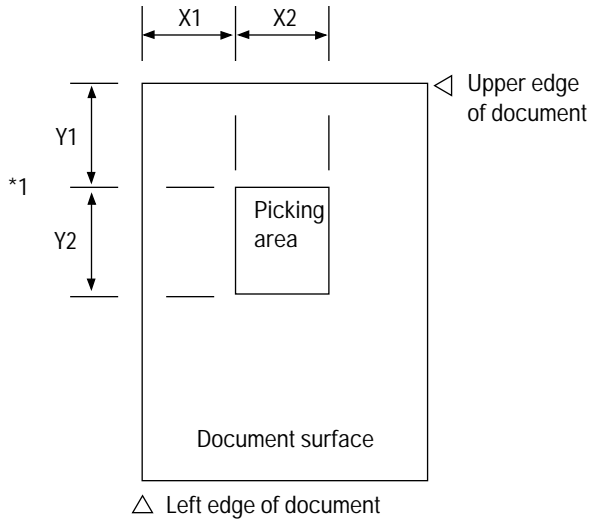
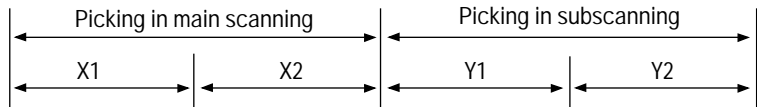
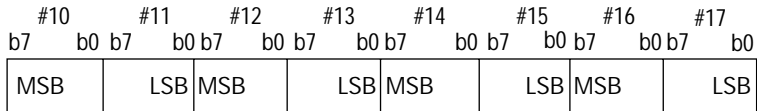

Operation error occurs when the values of X1 + X2 [(#10, #11) + (#12, #13)] and Y1 + Y2 [(#14, #15) + (#16, #17)] area more than the values shown below.

Scanner	X1 + X2	Y1 + Y2
M3099EX	4864	6912
M3099EH	3456	6912

- These values must be specified in binary in unit of 1/400-inch.

- Note:
1. When the picking is specified, only a specified area of the document is read. However, when the ADF is used, and the document length is shorter than the specified area, read operation is stopped at the edge of document.
 2. When the specified area is larger than the double-letter size, read area specification error occurs.
 3. When the jam detection bit (control register #2) is "1", a setting of Y2 is ignored.

Picking is specified when the scanner is required to read a special area as shown below.

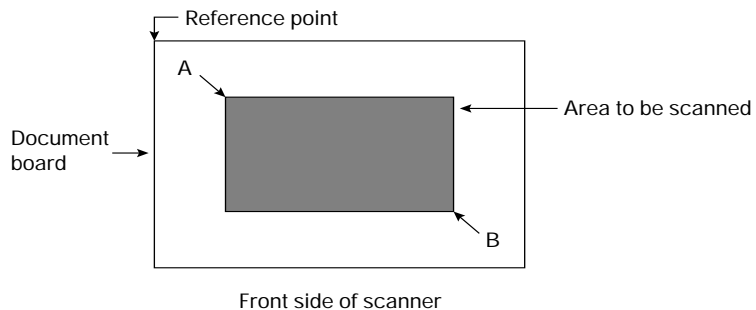

Picking is applied when bit 5 the control register #5 is "1" and the address of points A and B is specified in the control registers #10 to #17.

[Example]

CNT	CMD	REG. No.	#10	#11	#12	#13
			(#14)	(#15)	(#16)	(#17)

or

CNT	CMD	REG. No.	#10	#11	#12	#13	#14	#15	#16	#17
-----	-----	----------	-----	-----	-----	-----	-----	-----	-----	-----

Note: When these registers are specified, four consecutive registers (#10 to #13 or #14 to #17) must be specified.

Control register A#18

Control register B#18

X'00' is set when the power is turned on or when a CLEAR command is issued for initialization.

- This register reserved for future.

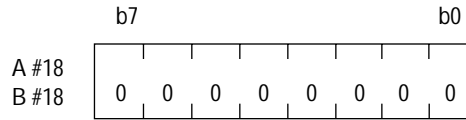

Control register A#19

Control register B#19

X'00' is set when the power is turned on or when a CLEAR command is issued for initialization.

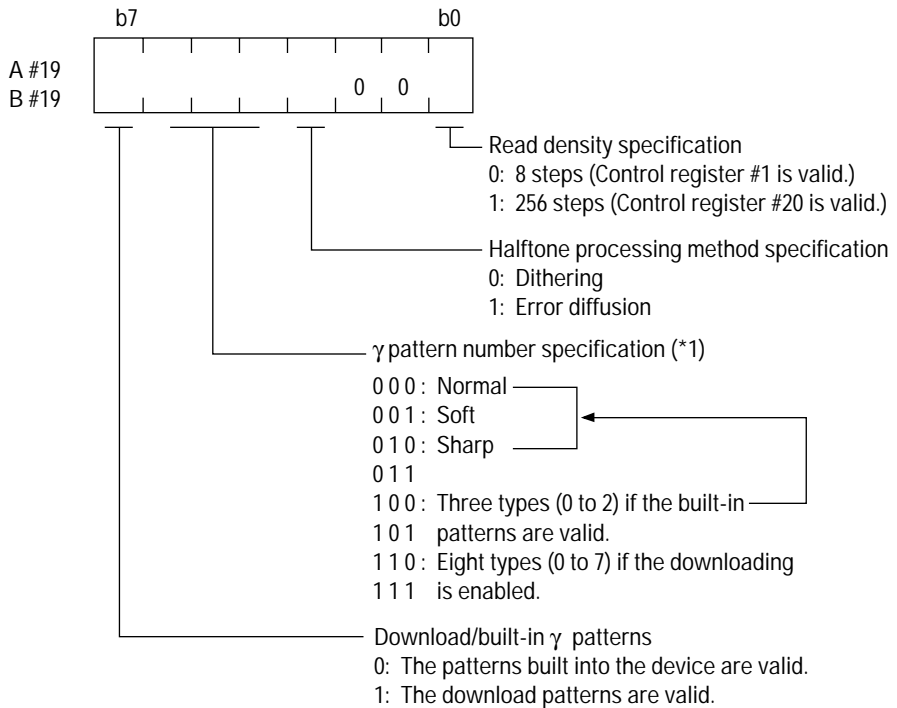

*1: If the built-in patterns are valid, 0 to 2 ('000' to '010') can be selected.

Control register A#20

Control register B#20

X'00' is set when the power is turned on or when a CLEAR command is issued for initialization.

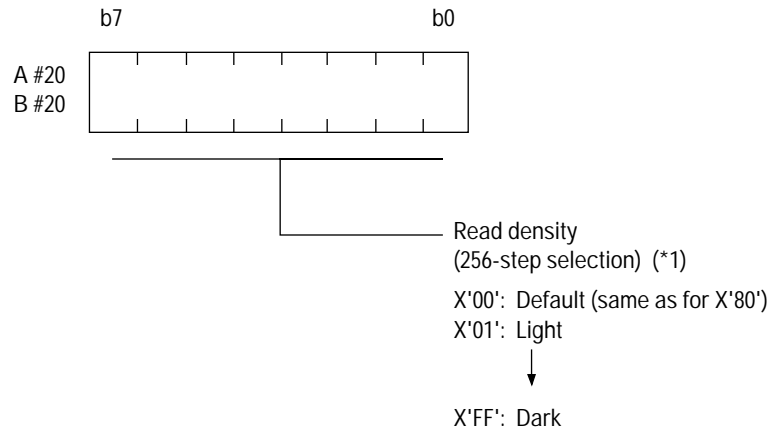

*1: This register is valid if bit 0 control register #19 is 1.

Control register A#21

Control register B#21

X'00' is set when the power is turned on or when a CLEAR command is issued for initialization.

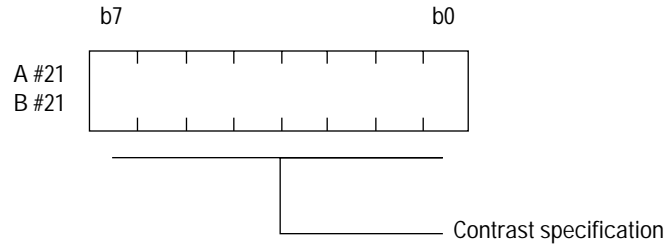

X'00': Default (same as for X'80')

X'01': Lowest contrast



X'80': Normal



X'FF': Highest contrast

IMAGE CONTROL command

This command sets the scanner to the operation mode of the image processing circuit.

Byte 1 CNT	Byte 2 CMD	Byte 3 TEXT	Byte 4 or later
X'0X'	X'5A'	Image control register start number	Image control register

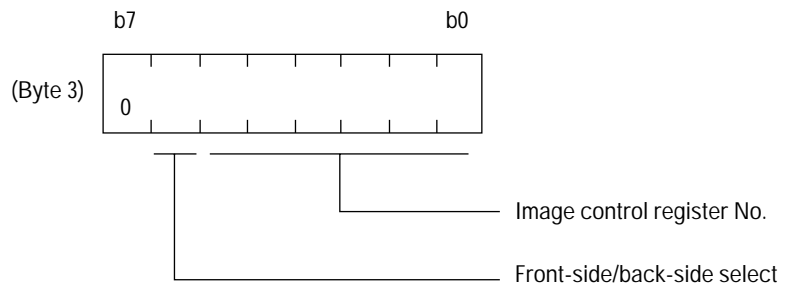

b6	Description
0	Selects image control register A (front-side)
1	Selects image control register B (back-side)

Note: If this command is sent to the scanner without image processing option (IPC II), the scanner sends "Operation error" as response.

Image control register

When the image processing option (IPC II) is connected, the following image processing can be executed. This register sets the image processing mode.

- Image area automatic separation function (simultaneous reading of characters and photographs)
- Inversion function (black/white conversion)
- Mirror image output function (right/left conversion)
- Image emphasis, outline extraction function
- Overlay function
- Simplified dynamic threshold.
- Zooming function ranging from 25% to 100% in 1% increments.

Image control register A#0, B#0

X'00' is set when the power is turned on or when a CLEAR command is issued for initialization.



This register must be sent before setting the image control registers #1 to #8.

Image control register A#1, B#1

X"00" is set when the power is turned on or when a CLEAR command is issued for initialization.

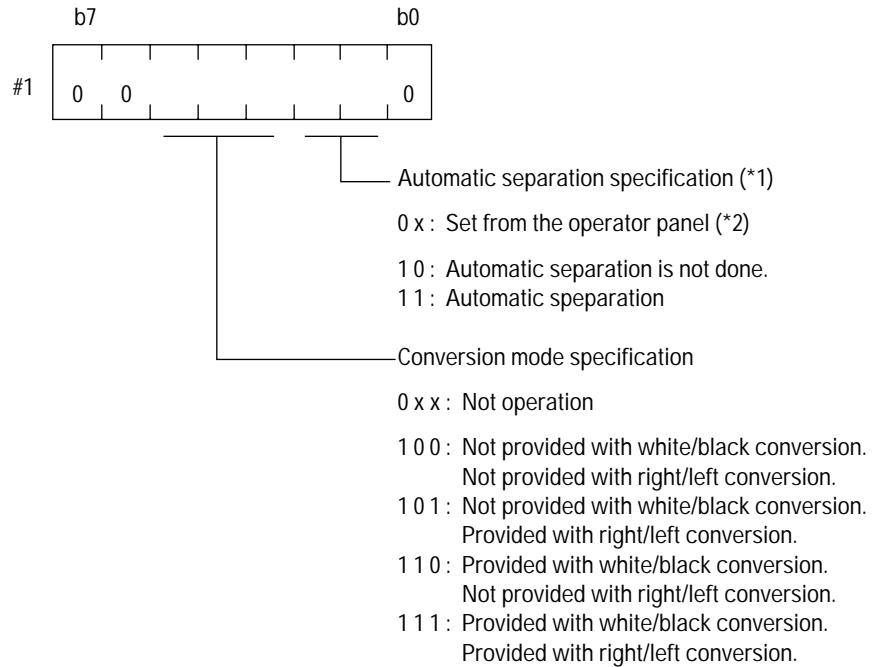

Note: Image control registers #1 to #3 must be sent in one sequence. One of automatic separation, image emphasis, outline extract, overlay can be specified.

- *1: Halftone specification (control register #2) is invalid in the automatic separation mode. However, halftone processing (dither or error diffusion) for photo area follows control register #19, and the dither pattern follows control register #2.
- *2: When automatic separation specification is based on operator panel, the bit 7 of image control register #2 and the bit 3 of image control register #3 must be set to '0'.

Image control register A#2, B#2

X'00' is set when the power is turned on or when a CLEAR command state is issued for initialization.

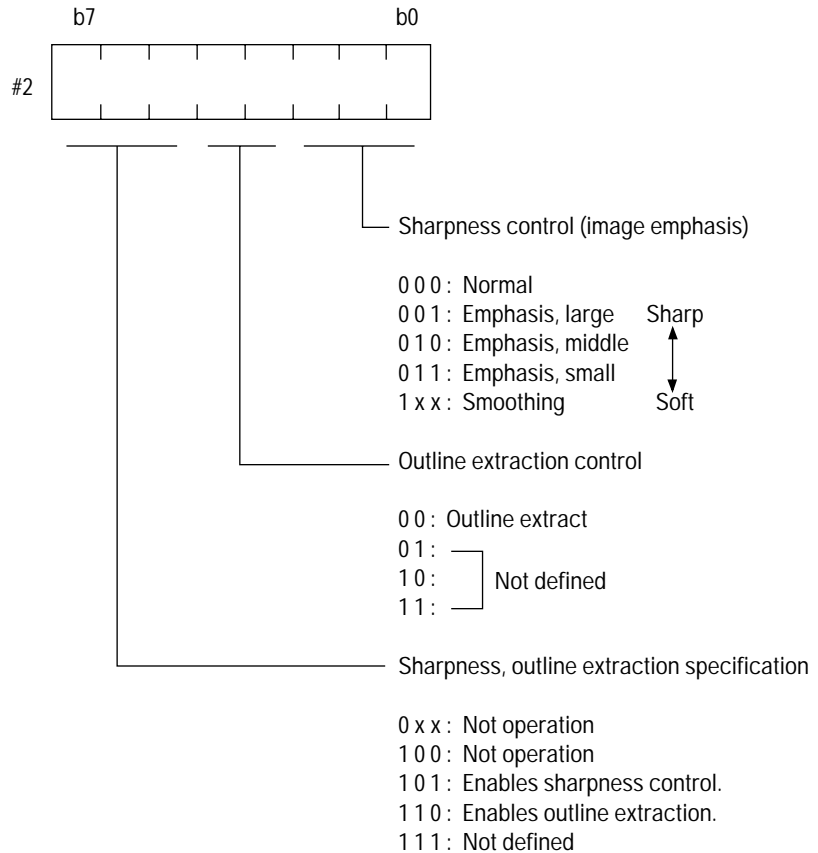
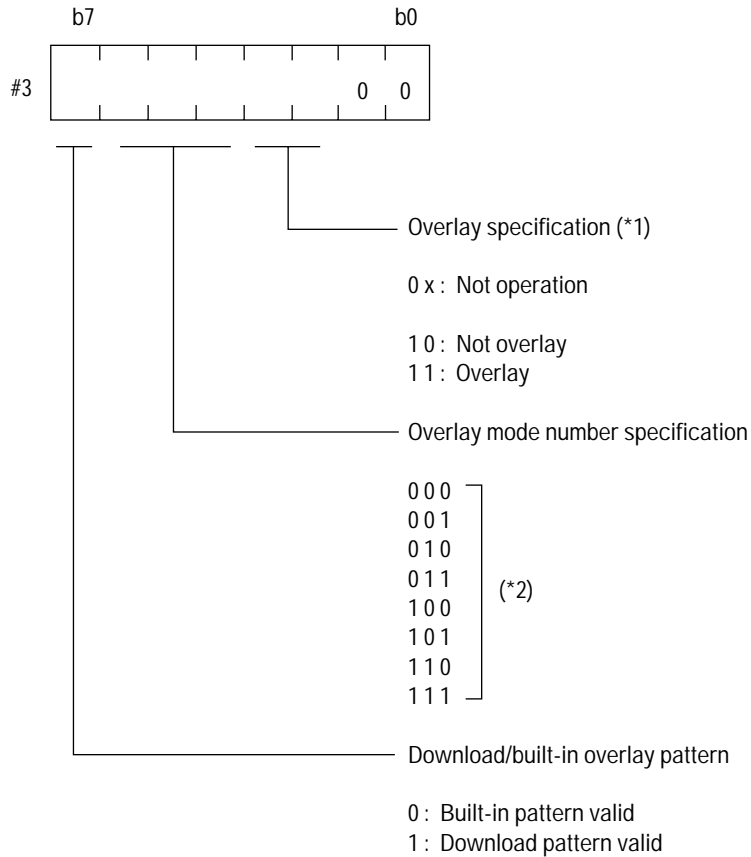

Image control register A#3, B#3

X'00' is set when the power is turned on or when a CLEAR command is issued for initialization.



*1: When dither or error diffusion processing is valid by the control register #2 or operator panel, overlay is not performed even if it is valid by this register.

*2: This scanner has six patterns as built-in overlay pattern. ("000" to "101")
Eight patterns can be registered as download pattern. ("000" to "111")
The bits 4 to 7 is valid when the overlay specification is valid.

Built-in overlay pattern

No. 0 Horizontal lines

00	00	00	00	00	00	00	00
00	00	00	00	00	00	00	00
00	00	00	00	00	00	00	00
00	00	00	00	00	00	00	00
FF	FF	FF	FF	FF	FF	FF	FF
FF	FF	FF	FF	FF	FF	FF	FF
FF	FF	FF	FF	FF	FF	FF	FF
FF	FF	FF	FF	FF	FF	FF	FF

No. 1 Vertical lines

00	00	00	00	FF	FF	FF	FF
00	00	00	00	FF	FF	FF	FF
00	00	00	00	FF	FF	FF	FF
00	00	00	00	FF	FF	FF	FF
00	00	00	00	FF	FF	FF	FF
00	00	00	00	FF	FF	FF	FF
00	00	00	00	FF	FF	FF	FF
00	00	00	00	FF	FF	FF	FF

No. 2 Angled pattern

FF	FF	FF	00	00	00	00	FF
FF	FF	FF	FF	00	00	00	00
00	FF	FF	FF	FF	00	00	00
00	00	FF	FF	FF	FF	00	00
00	00	00	FF	FF	FF	FF	00
00	00	00	00	FF	FF	FF	FF
FF	00	00	00	00	FF	FF	FF
FF	FF	00	00	00	00	FF	FF

No. 3 Dots pattern

FF	FF	FF	FF	00	00	00	00
FF	FF	FF	FF	00	00	00	00
FF	FF	FF	FF	00	00	00	00
FF	FF	FF	FF	00	00	00	00
00	00	00	00	FF	FF	FF	FF
00	00	00	00	FF	FF	FF	FF
00	00	00	00	FF	FF	FF	FF
00	00	00	00	FF	FF	FF	FF

No. 4 Triangle pattern

FF	FF	FF	FF	FF	FF	FF	FF
00	FF	FF	FF	FF	FF	FF	FF
00	00	FF	FF	FF	FF	FF	FF
00	00	00	FF	FF	FF	FF	FF
00	00	00	00	FF	FF	FF	FF
00	00	00	00	00	FF	FF	FF
00	00	00	00	00	00	FF	FF
00	00	00	00	00	00	00	FF

No. 5 Lattice pattern

00	00	00	00	00	00	00	00
00	00	00	00	00	00	00	00
00	00	FF	FF	FF	FF	00	00
00	00	FF	FF	FF	FF	00	00
00	00	FF	FF	FF	FF	00	00
00	00	FF	FF	FF	FF	00	00
00	00	00	00	00	00	00	00
00	00	00	00	00	00	00	00

Image control register A#4, B#4

X'00' is set when the power is turned on or when a CLEAR command is issued for initialization.

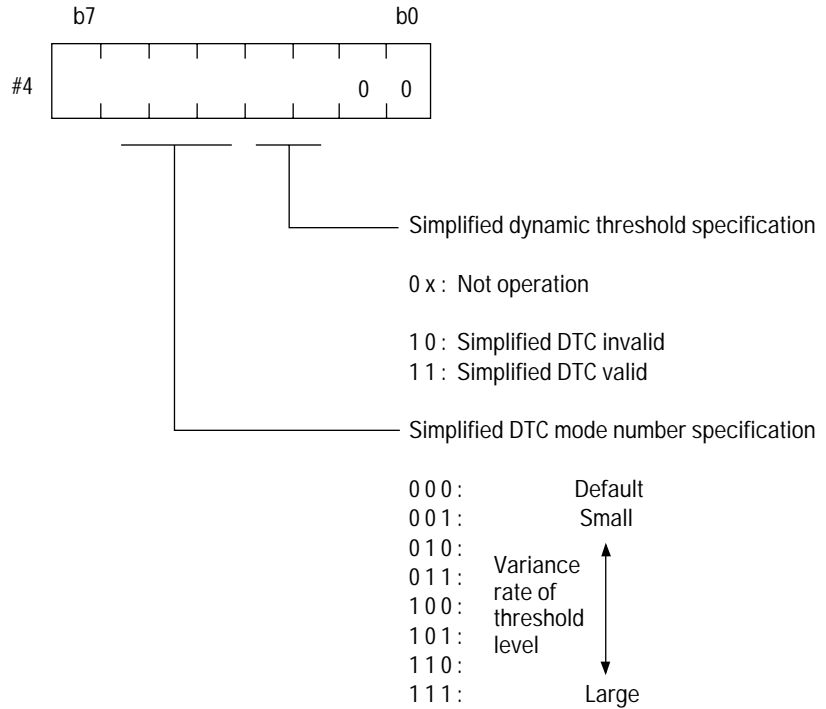

Eight parameter (000 to 111) can be specified as variance rate.

Image control register A#5 to #8

X'0864' is set when the power is turned on or when a CLEAR command is issued for initialization.

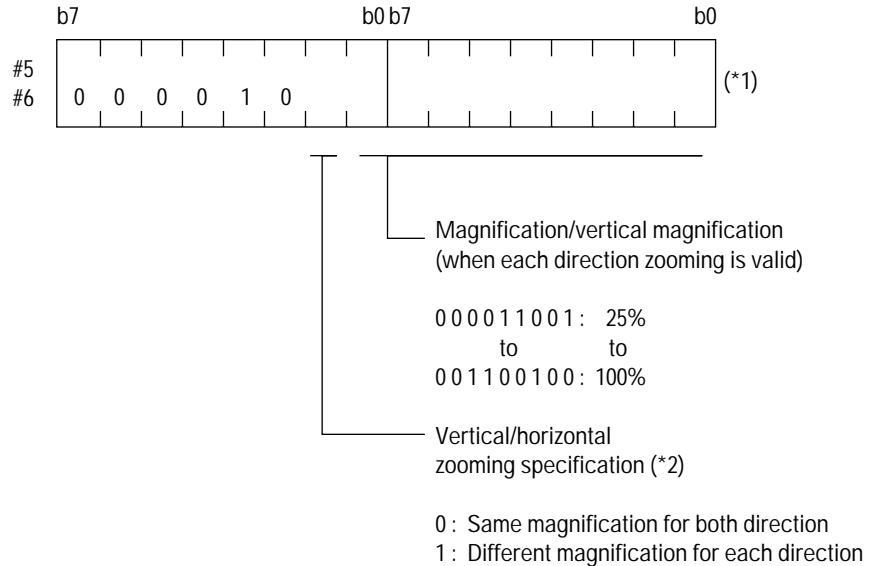

*1: Register A#5, #6, #7, and #8 must be sent consecutively.

*2: When the vertical/horizontal zooming specification is set to "0", the horizontal and vertical magnification is indicated. When this specification is set to "1", vertical magnification is specified at bit 0 of the register A#5 and at all bits of the register A#6.

Example

How to calculate the output resolution:

- Control register #1 is X'0B' (200 dpi)
- Image control register A#5 and A#6 are X '0819' (25%)
- Output resolution = 200 dpi \times 0.25 = 50 dpi.

X'0000' is set when the power is turned on or when a CLEAR command is issued for initialization.

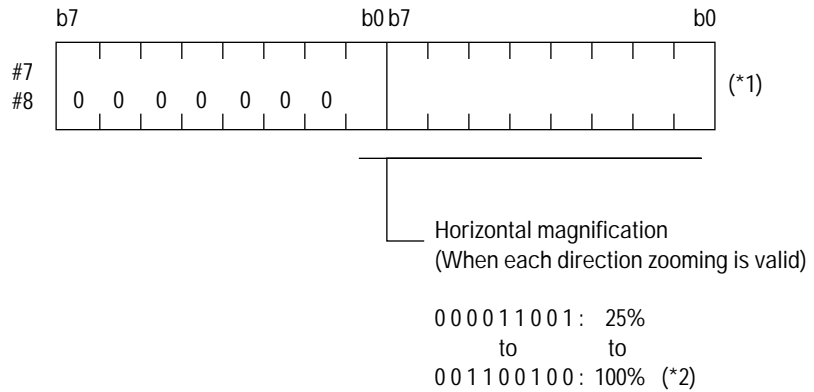

*1: Magnification is valid only when the horizontal/vertical zooming specification (bit 1 of the register A#5) is set to "1".

*2: Document magnification has the following limitations:
Maximum main scanning data: 608 bytes/line

$$\frac{A \times (B/400) \times (C/100)}{8} \leq 608 \text{ (bytes)}$$

A: Main scan width (unit: number of pixels when scanned at 400 dpi)

B: Basic resolution (set from operator panel or control register #0: 200, 240, 300, 400 dpi)

C: Horizontal magnification (25 to 100%)

This expression is rounded up to the integer.

Image control register B#5 to #8

Since these registers are not supported, specify X'08000000'.

PRINT CONTROL command

Instructs how to print to the manuscript.

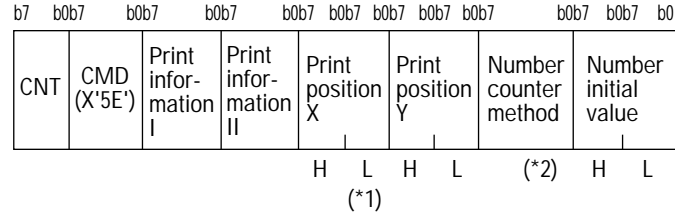

*1: For this scanner, set X'0000'.

*2: For this register, set X'00' if number print processing is not being performed.

Print information I register

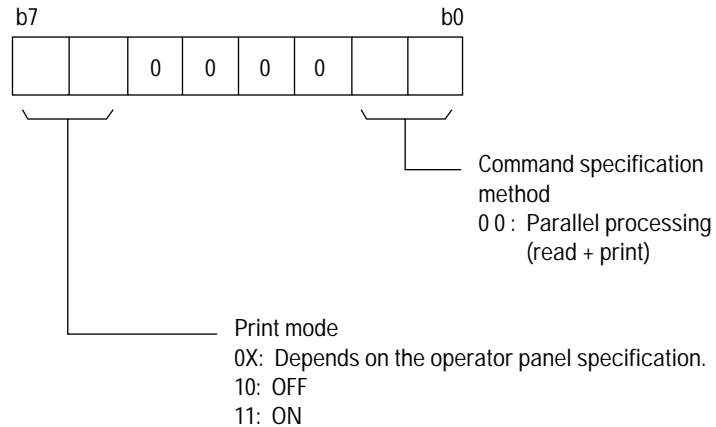

Print information II register

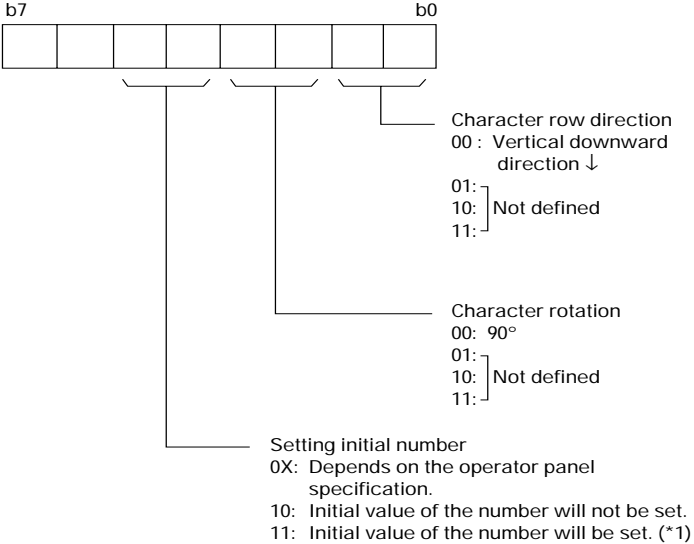

*1: Set initial number again after changing counting number register.

Print position Y register

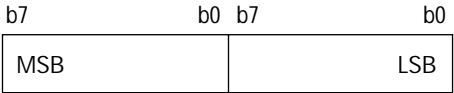

Specify the value in binary code in unit of 1/400 inch.

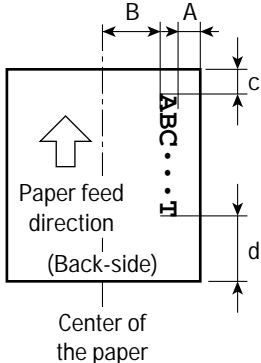

$$\text{Print position } Y = \frac{C-20}{0.0635}$$

(unit of c: mm)
(1/400 inch=0.0635 mm)

- Limit of the print position
- A > 5 mm
 - B > 28 mm
 - c > 20 mm
 - d > 5 mm

Number counter method register

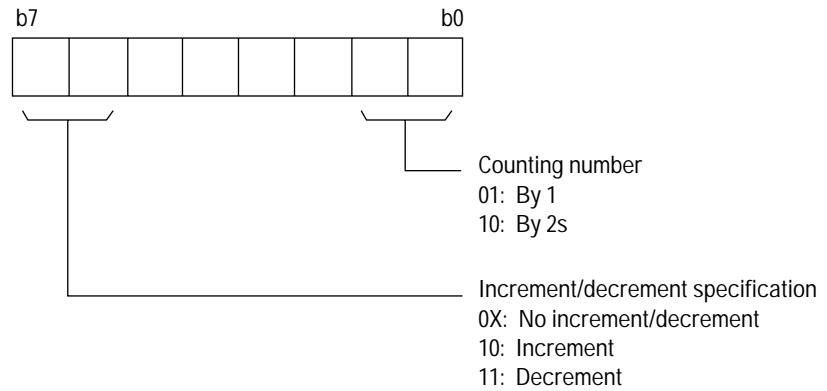

Number initial value register

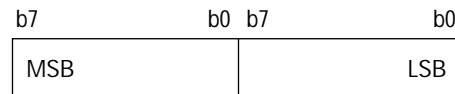

The default for this device is X'0000".

X'0000' to X'FFFF' can be specified.

START command

When the scanner receives this command, this scanner reports the size of document being read.

Byte 1 CNT	Byte 2 CMD	Byte 3 or later
X'02'	X'53'	—

READ command

When the scanner receives this command, the scanner starts reading based on the previously set operation mode.

Issuing the response other than Read Complete during read operation causes error.

Byte 1 CNT	Byte 2 CMD	Byte 3 or later
X'02'	X'54'	—

SENSE command

When the scanner receives this command, the scanner reports the scanner status. The sense command can be issued at any time if another command does not require the response from the scanner.

Byte 1 CNT	Byte 2 CMD	Byte 3 or later
X'02'	X'41'	—

RETURN SENSE command

Same as SENSE command. But the scanner does not report the temporary error.

Byte 1 CNT	Byte 2 CMD	Byte 3 or later
X'02'	X'42'	—

IMAGE MODE SENSE command

This command is valid for the scanner with the image processing circuit. When the scanner receives this command, the scanner reports the image processing mode of the main window and number of pixels (Unit: Byte) per line in the X-direction. By specification byte 3 of this command, the front or back-side image status can be selected.

Byte 1 CNT	Byte 2 CMD	Byte 3 TEXT
X'03'	X'43'	

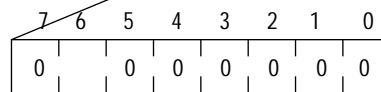

0 : Front-side image status received
1 : Back-side image status received

INQUIRY command

When the scanner receives this command, the scanner reports a device information report.

Byte 1 CNT	Byte 2 CMD
X'02'	X'40'

SEND DITHER 1 command

This command is valid for the scanner with the image processing circuit. By this command, download patterns of dither or overlay pattern can be registered.

Byte 1 CNT	Byte 2 CMD	Byte 3 TEXT	Byte 4 or later
X'43'	X'46'	Dither or overlay pattern number	Pattern data to be registered

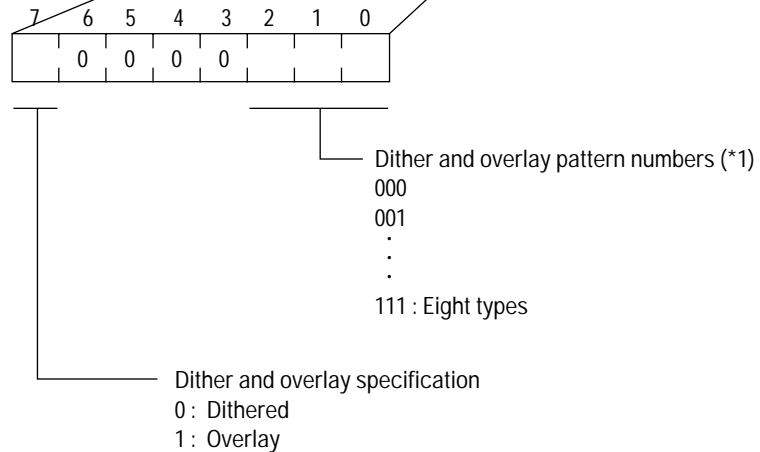

*1: Up to eight types, from #0 to #7, can be registered for dither pattern or overlay pattern. When the power to the scanner is turned off or when the scanner is reset, registration must be done again. When a pattern is built in, registration need not be done again.

Pattern data format

1 byte data corresponds to data for 1 dot.

- For dither pattern
X'00' to X'FF' should be sent as dither pattern.
- For overlay pattern
X'00' or X'FF' should be sent
When the data is X'FF', the data of the dot is changed to white.
When the data is X'00', the data of the dot is not changed.

Transfer the dither and overlay patterns in the order shown below.

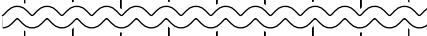
1	2	3	4	5	6	7	8
9	10	11	12	13	14	15	16
17	18	19	20	21	22	23	24
							
41	42	43	44	45	46	47	48
49	50	51	52	53	54	55	56
57	58	59	60	61	62	63	64

(8 × 8 matrix)

Download is optional.

SEND DITHER 2 command

Byte 1 CNT	Byte 2 CMD	Byte 3	Byte 4, 5	Byte 6	Byte 7 or later
X'05'	X'47'	Reserved X'00'	Count A (*1)	Dithering γ , and overlay pattern number	Dithering γ , and overlay pattern (count A-1) byte

- For the SEND DITHER 1 command, the dithered matrix size is always 8×8 .
- For the SEND DITHER 2 command, the dithered matrix size is variable ($n \times n$).

($n \% 32$) Data can also be download.

*1: Count A (bytes 4 and 5) contains the number of data a units from byte 6 or a subsequent byte. (256 bytes or more data can be transferred.)

Example: SEND DITHER 2 command

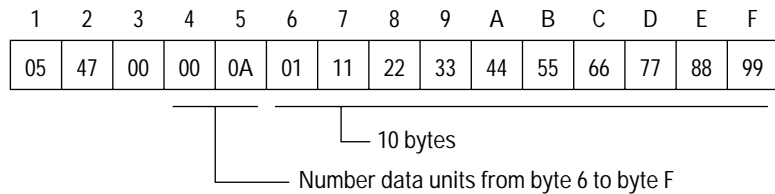

Byte6: Dithering, γ , or overlay pattern number, and the corresponding pattern

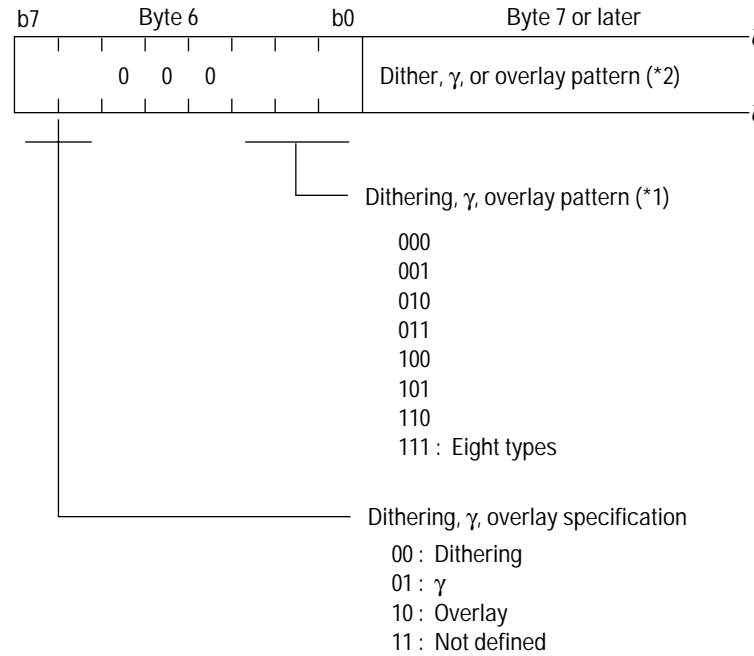

*1: Eight dithering, eight γ , and eight overlay patterns (0 to 7) can be registered. If the scanner is turned off, or reset, they must be registered again. If the patterns built into the scanner are used, they need not be registered.

*2: Dithering and overlay patterns must be transferred in the following order:

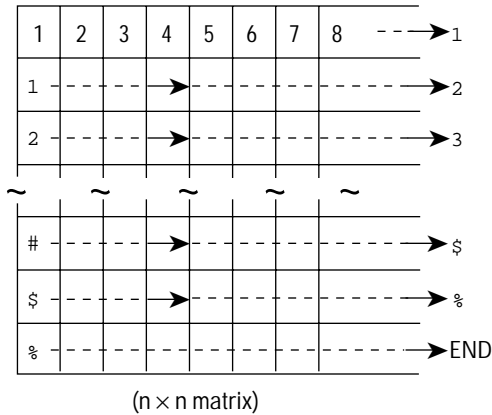

The γ patterns must be transferred in the following order and format (SEND DITHER 2 is used).

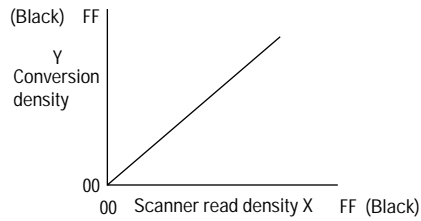
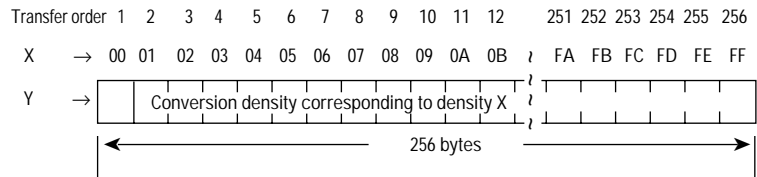

Note: For overlay pattern matrix data, X'FF' or X'00' must be set.

X'FF': Force the corresponding pixel to be white.

X'00': Binarizes the corresponding pixel based on the specified slice (density). For a floating slice, it is binarized based on the normal density.

[Example]

00	00	00	00	FF	FF	FF	FF
00	00	00	00	FF	FF	FF	FF
00	00	00	00	FF	FF	FF	FF

~ ~ ~ ~ ~

00	00	00	00	FF	FF	FF	FF
00	00	00	00	FF	FF	FF	FF
00	00	00	00	FF	FF	FF	FF

(8 × 8 matrix)

SEND DATA command

Transfers print pattern and data items.

Byte 1 CNT	Byte 2 CMD	Byte 3 TEXT	Byte 4 or later
X'XX'	X'48'	Print information III (*1)	Print (data)

*1: For this scanner, set X'00".

Print information III register (Added to the Send Dither 3 command)

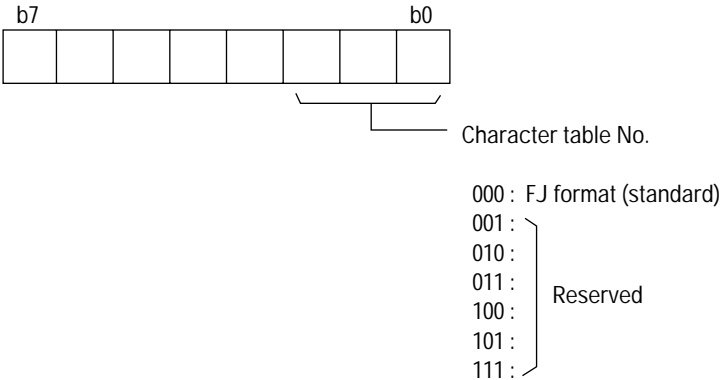

Print data

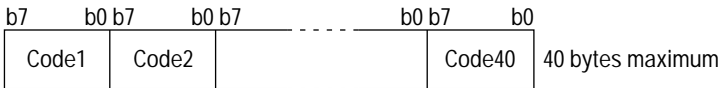

Print data format

ABCD %05ud
 Character code (*1) Print code number (fixed) (*1) (*2)

The combination is as follows:

Combination	Example
Only Character	<u>ABCD</u>
Character + Print number	<u>ABCD</u> <u>%05ud</u>
Only Print number	<u>%05ud</u>

The sum of the number of the character codes and print code numbers must not exceed 20 (digits).

% is a special command. If %% is specified, one % character is printed.

- *1: These code must be in ASCII code.
- *2: When you intend to print the number, please put '%05ud'. Then the scanner prints the numbers in accordance with the information of the register of PRINT CONTROL command. Printing number is only five figures.

Example

In case of printing “XYZABC00001”

PRINT CONTROL command

Byte 1	Byte 2	Byte 3	Byte 4	Byte 5	Byte 6	Byte 7	Byte 8	Byte 9	Byte 10	Byte 11
X'0B'	X'5E'	X'C0'	X'30'	X'00'	X'00'	X'00'	X'00'	X'81'	X'00'	X'01'

SEND DATA command

Byte 1	Byte 2	Byte 3	Byte 4	Byte 5	Byte 6	Byte 7	Byte 8	Byte 9	Byte 10	Byte 11	Byte 12	Byte 13	Byte 14
X'0E'	X'48'	X'00'	X'58'	X'59'	X'5A'	X'41'	X'42'	X'43'	X'25'	X'30'	X'35'	X'75'	X'64'

As a result:

“XYZABC00001”	1st sheet
“XYZABC00002”	2nd sheet
⋮	⋮
↓	↓
“XYZABC65535”	65535th sheet
“XYZABC00000”	65536th sheet
↓	
repeat	

Responses

Table 3.7 lists the response for the commands sent from the scanner to the host computer.

Table 3.7 Response

Response	Response Code	Details
Ready	52	Completion of scanner initialization
Normal Status	4E	Response to command reception
Image Status	4C	Reporting the image processing mode for each main window and the number of bytes per line in the X-axis direction
Unit Status	4A	Reporting the device information
Read Complete	46	Completion of READ command reception
Operation Error Error	55	Occurrence of error related to operation specification program
Temporary Error	54	Occurrence of Temporary error
Equipment Error	50	Occurrence of device fault

Response \ BYTE	1	2	3	4	5	6 or later
Ready	02	52	–	–	–	–
Normal Status	06	4E	Device information I	Device information II-i	Device information II-ii	Device information II-iii
Normal Status (*1)	04	4E	Device information I	Device information II-i	–	–
Image Status	0C	4C	Device information III to device information XII (10 bytes)			
Unit Status	1E	4A	Device function information I to VII			
Read Complete	06	46	Device information I	Device information II-i	Device information II-ii	Device information II-iii
Read Complete (*1)	04	46	Device information I	Device information II-i	–	–
Operation Error Error	03	55	Detailed error information I	–	–	–
Temporary Error	03	54	Detailed error information II	–	–	–
Equipment Error	03	50	Detailed error information III	–	–	–

*1: The "Normal status" and "Read Complete" data lengths can be set to either four or six bytes in the EEPROM.

Ready

This response indicates that the scanner initialization is complete.

Byte 1 CNT	Byte 2 RPS	Byte 3 or later
X'02'	X'52'	—

Normal status

This response is for command reception and includes device information. Device information indicates the status of scanner operation.

Byte 1 CNT	Byte 2 RPS	Byte 3	Byte 4
X'04'	X'4E'	Device Information I	Device Information II-i

Byte 1 CNT	Byte 2 RPS	Byte 3	Byte 4
X'06'	X'4E'	Device Information I	Device Information II-i to II-iii

Device information indicates the status of the scanner operation.

Device information I

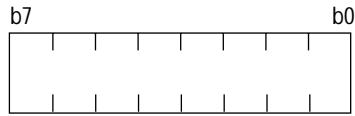

Resolution

000 : 400 dpi

001 : 300 dpi

010 : 240 dpi

011 : 200 dpi

100 :]

101 :]

110 :]

111 :]

Not defined

Document size

0xxx : Invalid (Not defined)

1000 : A0]

1001 : A1]

10010 : A2]

Not defined

10011 : A3 (Defined only M3099EX)

10100 : A4

10101 : A5

10110 : Double-letter (Defined only M3099EX)

10111 : Letter

11000 : B0]

11001 : B1]

11010 : B2]

11011 : B3]

Not defined

11100 : B4 (Defined only M3099EX)

11101 : B5

11110 : Not defined

11111 : Legal

Device information II-i

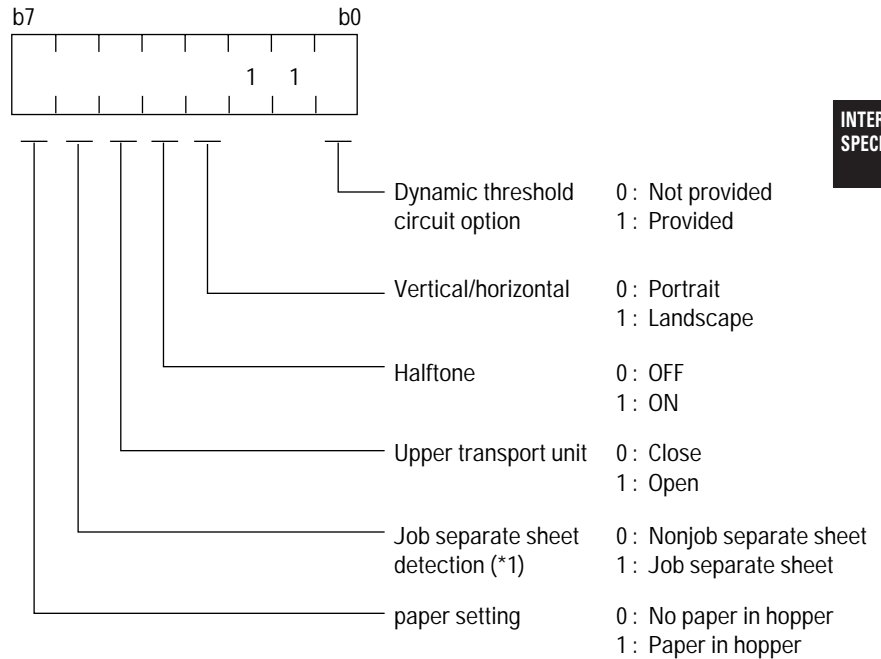

*1: This bit is valid when it is specified in Normal status response for the START command.

Device information II-ii

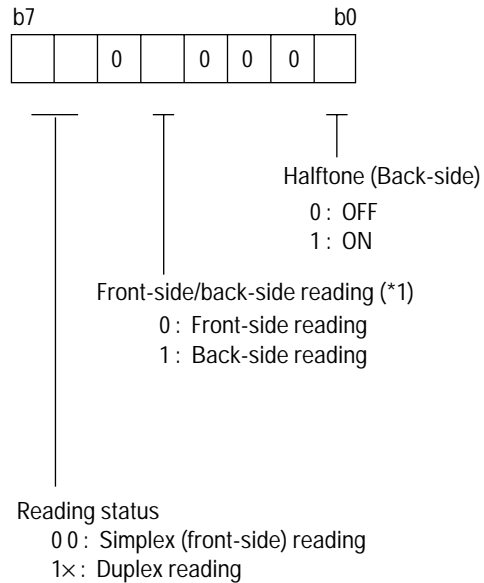

*1: This bit is available only in the case of "Normal status" to START command or "Read complete" to READ command. (What indicates which data is transferred, front-side data or back-side data.)

Device information II-iii

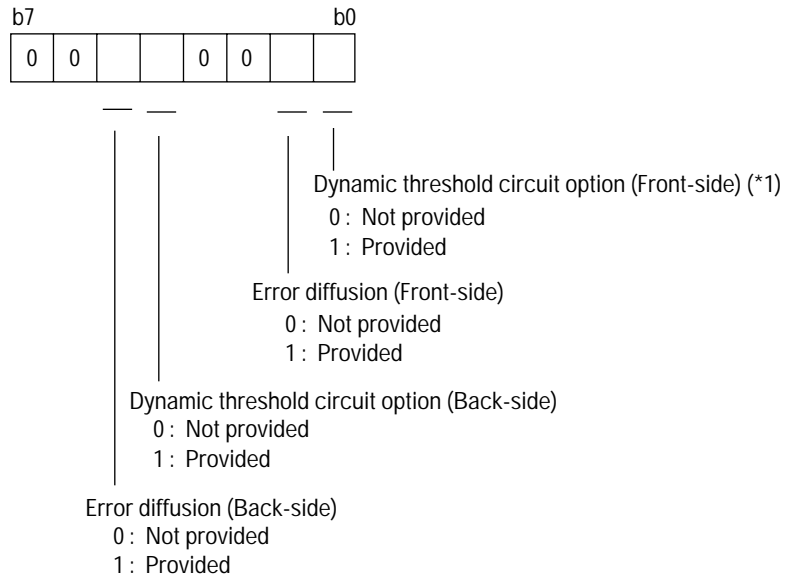

*1: This bit is same as bit 0 of device information II-i.

Image status

This response reports the status of the image processing function.

Byte 1 CNT	Byte 2 RPS	Byte 3 or later
X'0C'	X'4C'	Device Information III to XII

Device information III

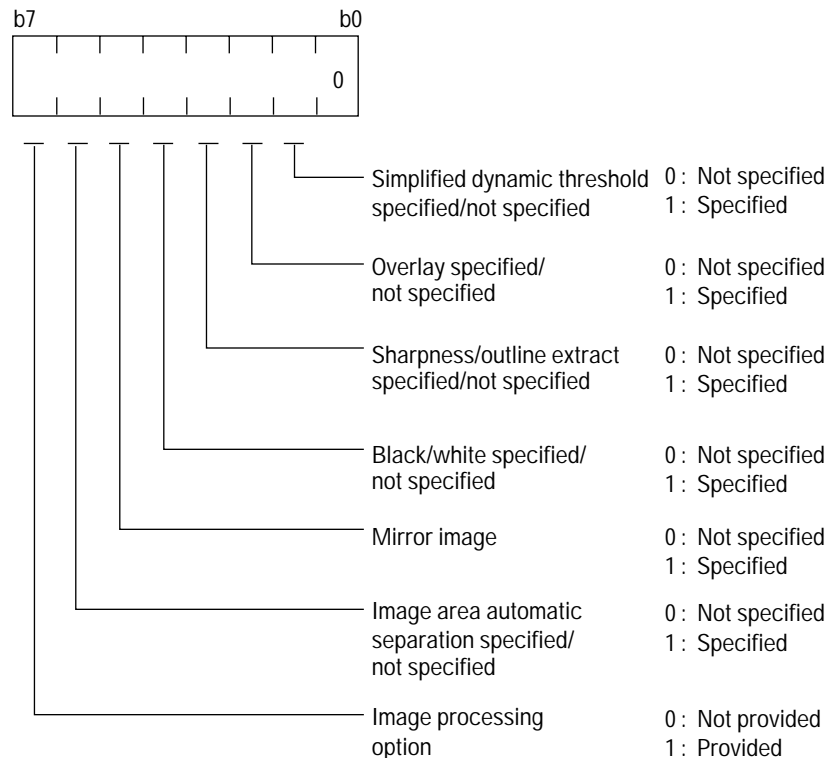

Device information IV

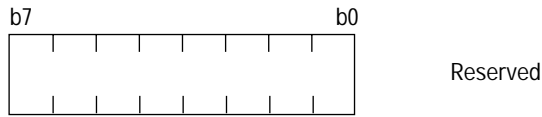

Device information V, VI

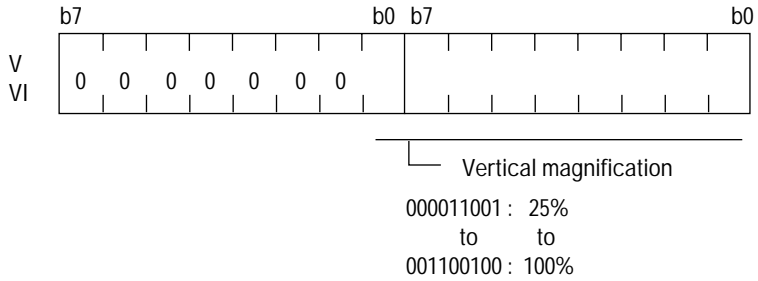

Device information VII, VIII

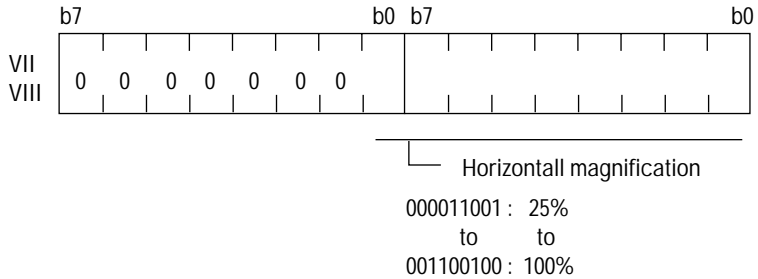

Device information IX, X

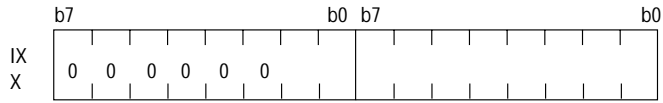

Number of bytes per line in the X-axis direction
000000001
to
100110000 : Maximum 608 bytes

Device information XI, XII



Number of lines in the Y-axis direction

Note: X'0000' is sent when ADF mode is selected.

Unit status

This response reports the device information.

Byte 1 CNT	Byte 2 RPS	Byte 3 or later
X'1E'	X'4A'	Device function information I to VII

Device function information indicates the device information of the scanner.

Device function information I

Device function information I indicates type information of the scanner.

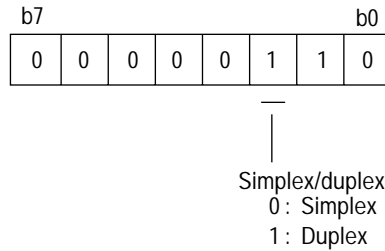

Device function information II

Device function information II indicates scanning resolution supported of the scanner.

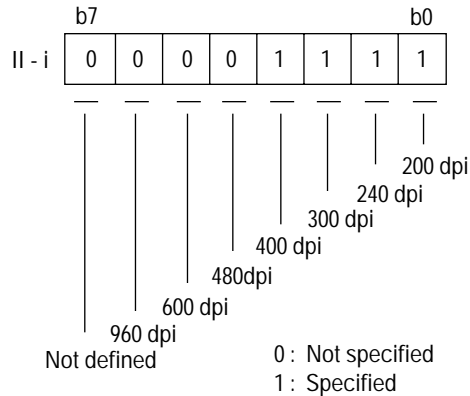

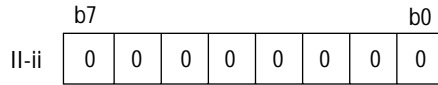

(Reserved)

Device function information III

Device function information III indicates document size supported of the scanner.

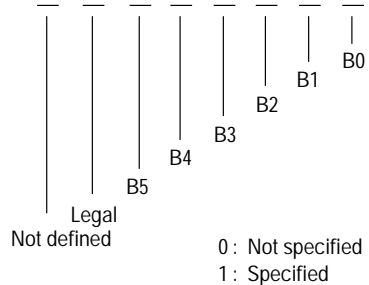
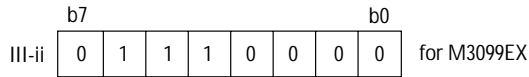
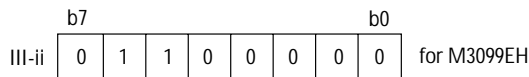
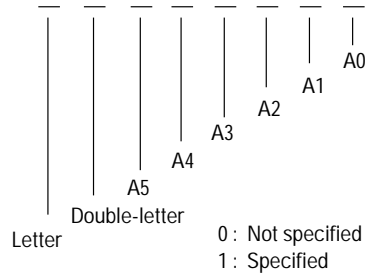
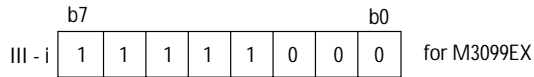
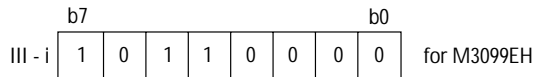

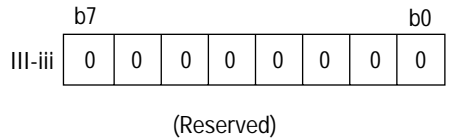

Device function information IV

Device function information IV indicates image processing function of front-side supported of the scanner.

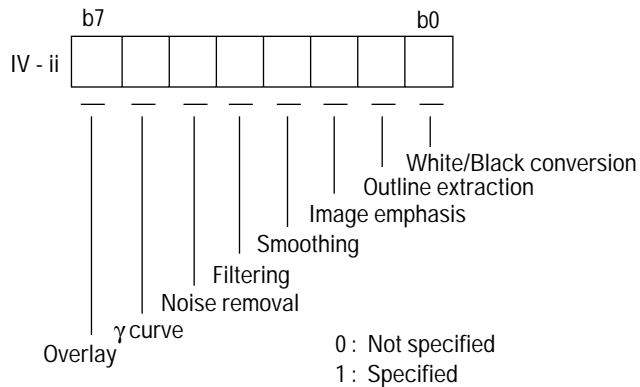
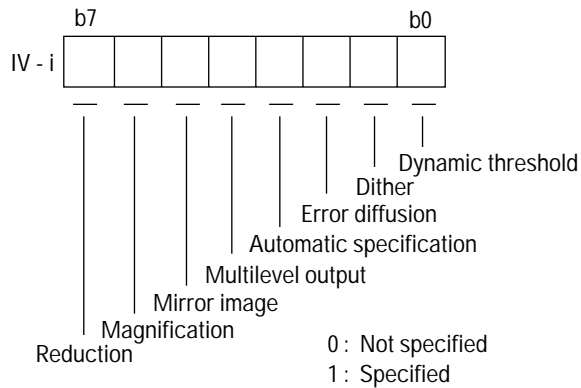

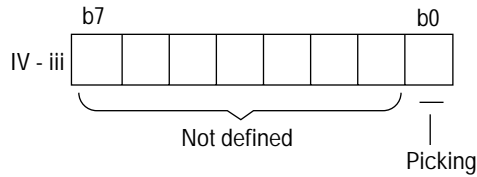

0 : Not specified
1 : Specified

Device function information V

Device function information V indicates image processing function of back-side supported of the scanner.

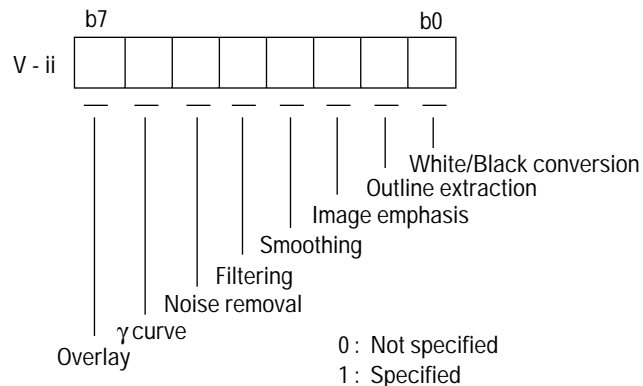
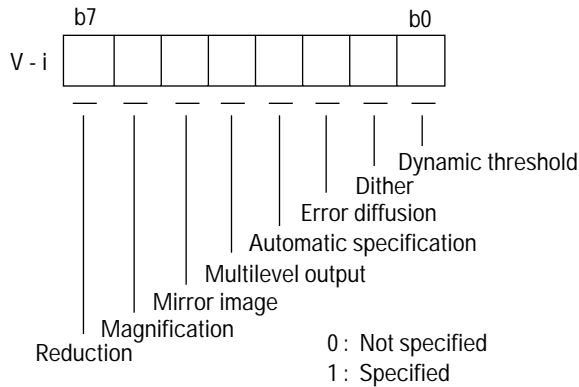

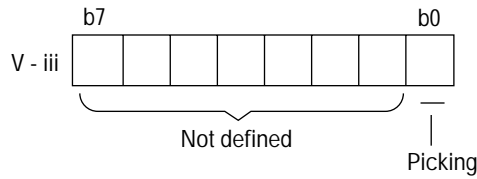

0 : Not specified
1 : Specified

Device function information VI

Device function information VI indicates option information of the scanner.

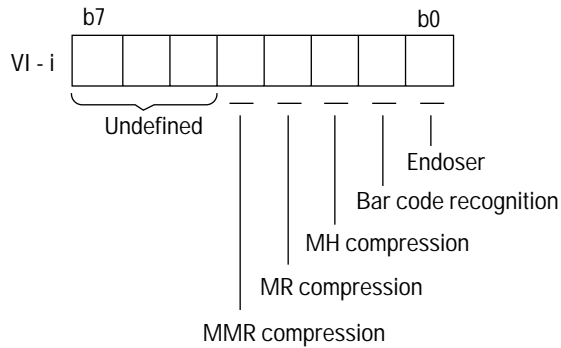

0 : Not specified
1 : Specified

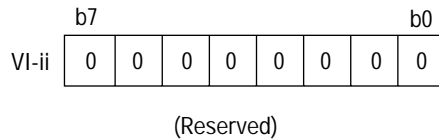

Device function information VII

Device function information VII indicates image memory information of the scanner.

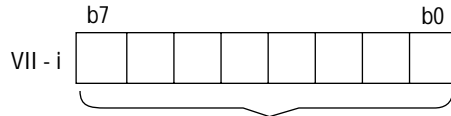

Memory size for imag's of front-side

X 'xx' × 0.5 MB

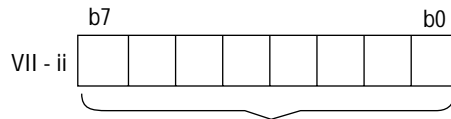

Memory size for imag's of back-side

X 'xx' × 0.5 MB

Read complete

This response indicates that READ command execution terminated normally.

Byte 1 CNT	Byte 2 RPS	Byte 3 TEXT	Byte 4 or later
X'04'	X'46'	Device Information I	Device Information II-i

Byte 1 CNT	Byte 2 RPS	Byte 3 TEXT	Byte 4 or later
X'06'	X'46'	Device Information I	Device Information II-i to II-iii

Device information indicates the status of the scanner operation.

Device information I

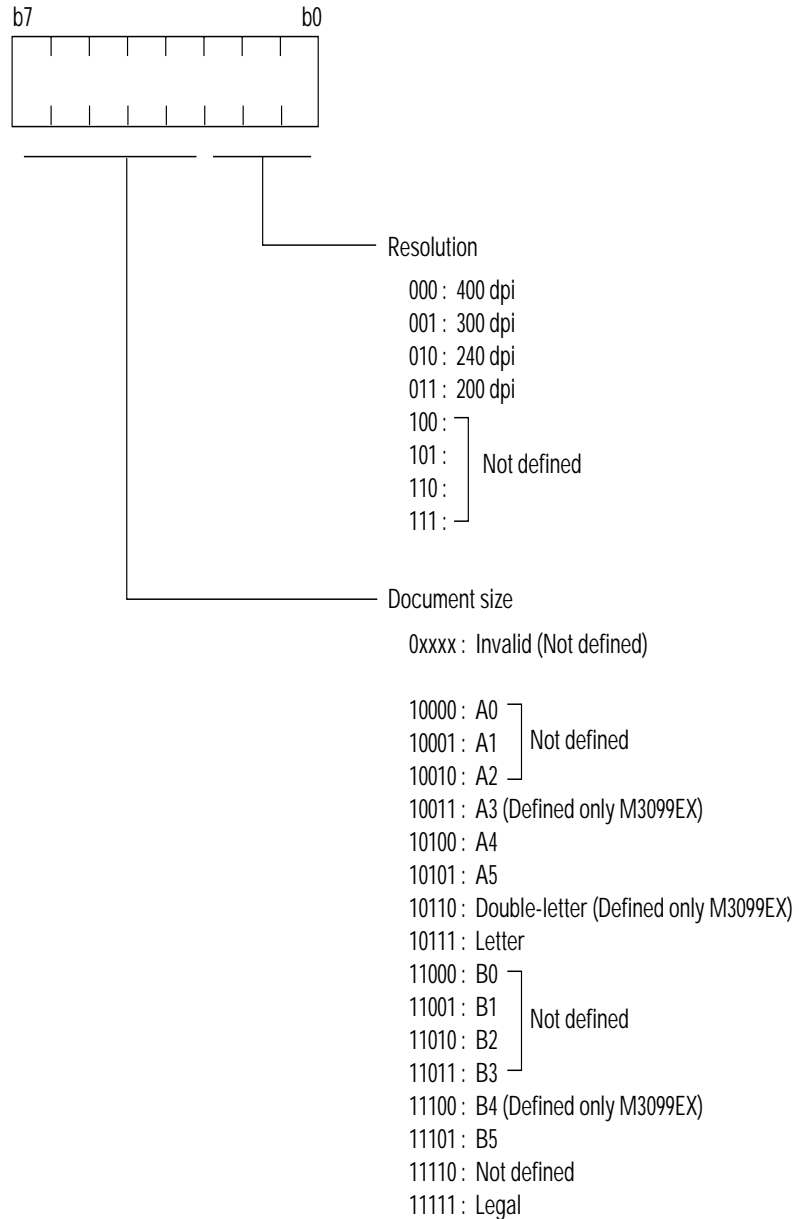

Device information II-i

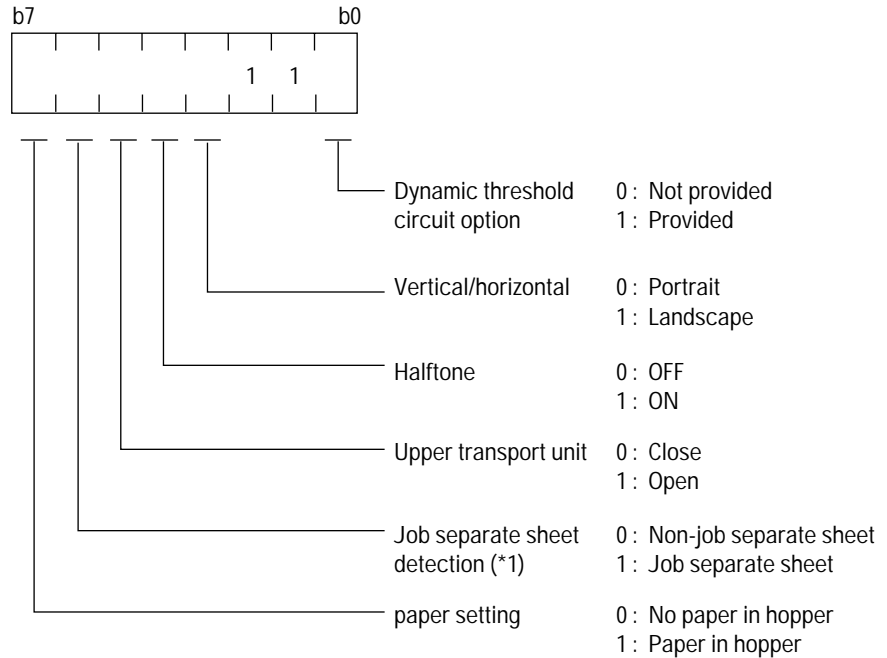

*1: This bit is valid when it is specified in Normal status response for the START command.

Device information II-ii

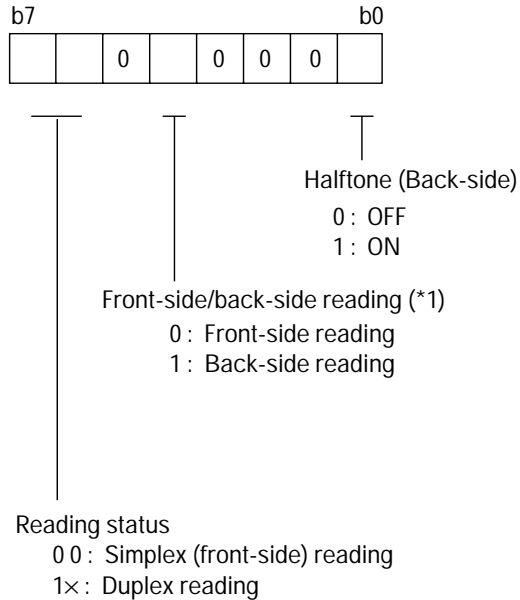

*1: This bit is available only in the case of "Normal status" to START command or "Read complete" to READ command. (What indicates which data is transferred, front-side data or back-side data.)

Device information II-iii

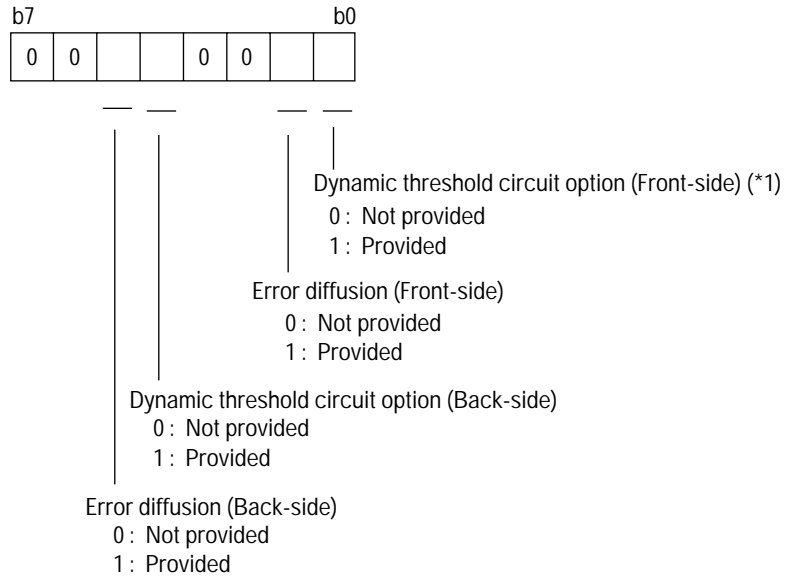

*1: This bit is same as bit 0 of device information II-i.

Operation error

This response indicates that the error related to operation specification program occurs.

Byte 1 CNT	Byte 2 RPS	Byte 3 TEXT
X'03'	X'55'	Detailed error Information I

Detailed information I

Detailed information I gives details on errors in command/response transmission and reception to and from the host computer.

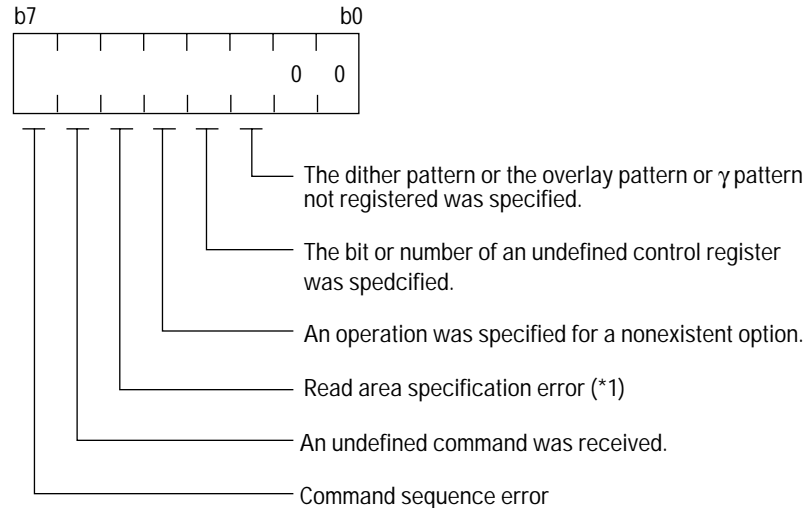

*1: Although standard document size bit on control register 5 is on, (Bit 7 takes "1" and bit 6 takes "0"), the size specifying bits (bits 0 to 4) are not defined.

Control register contents do not change even if the above errors are detected.

Temporary error

This response indicates that the temporary error occurs.

Byte 1 CNT	Byte 2 RPS	Byte 3 TEXT
X'03'	X'54'	Detailed error Information II

Detailed information II

Detailed error information II provides details of temporary errors that can be corrected by operator intervention.

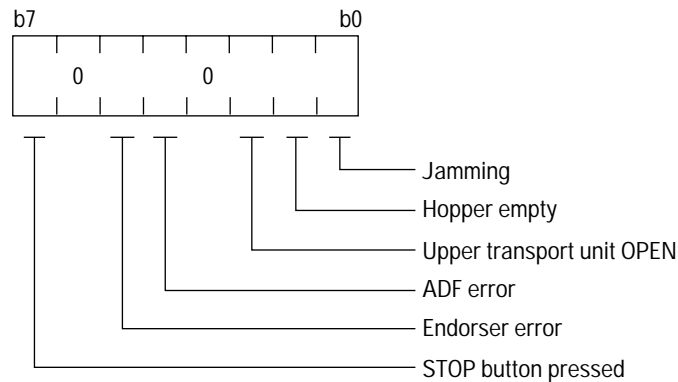

Jamming

Paper jammed in the document path during ADF operation.

- Document already existed in ADF before the READ command was executed.
- Document did not pass the sensor in ADF within the specific time.
- Double feeding occurred.

Hopper empty

There were no document on the hopper when the READ command was received during ADF operation.

Upper transport unit open

The upper transport unit was opened during ADF operation or the upper transport unit was open when ADF reading began.

ADF error

The roller unit wasn't set when the hopper table was up, or document more than limitation was stacked on the hopper table.

Endorser error

When endorser use is specified and start command signal is received, either a printer head is not installed or a head error has occurred.

STOP button pressed

The Stop button was pressed during reading or while the scanner was waiting for the operator to press the Start button.

Equipment error

This response indicates that the device fault occurs.

Byte 1 CNT	Byte 2 RPS	Byte 3 TEXT
X'03'	X'50'	Detailed error Information III

Detailed information III

Detailed error information III provides details of the scanner errors that require a call to CE.

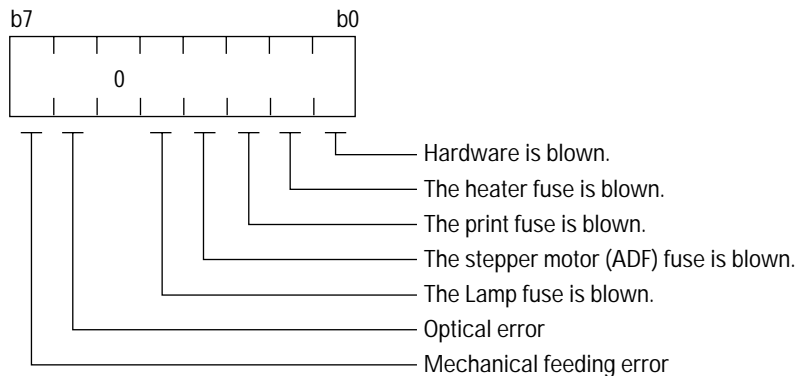

Details sequence

Initialization

Figure 3.6 shows the command/response sequence for initialization.

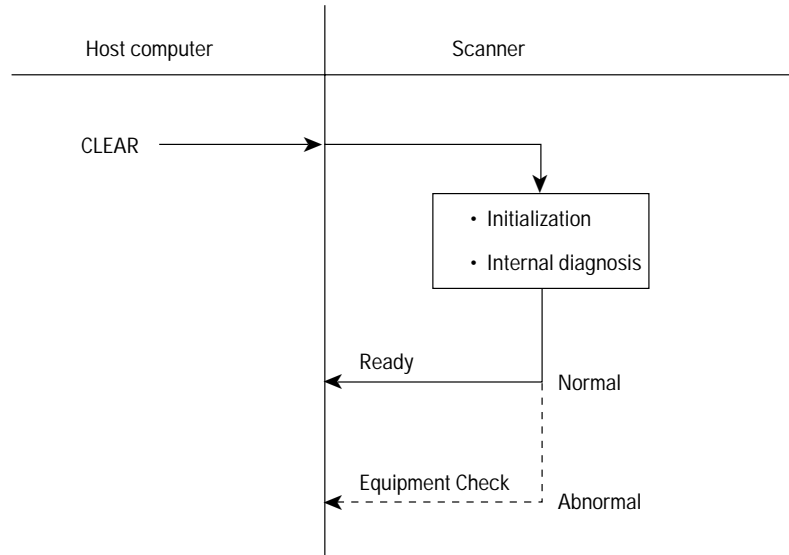

Figure 3.6 Command/response sequence for initialization

Note: The maximum time from the CLEAR command reception to the returning of a response is 10 seconds after warm up is complete.

Read operation

Figure 3.7 to Figure 3.9 shows the command/response sequences for the read operation.

Automatic start mode duplex reading (ADF)

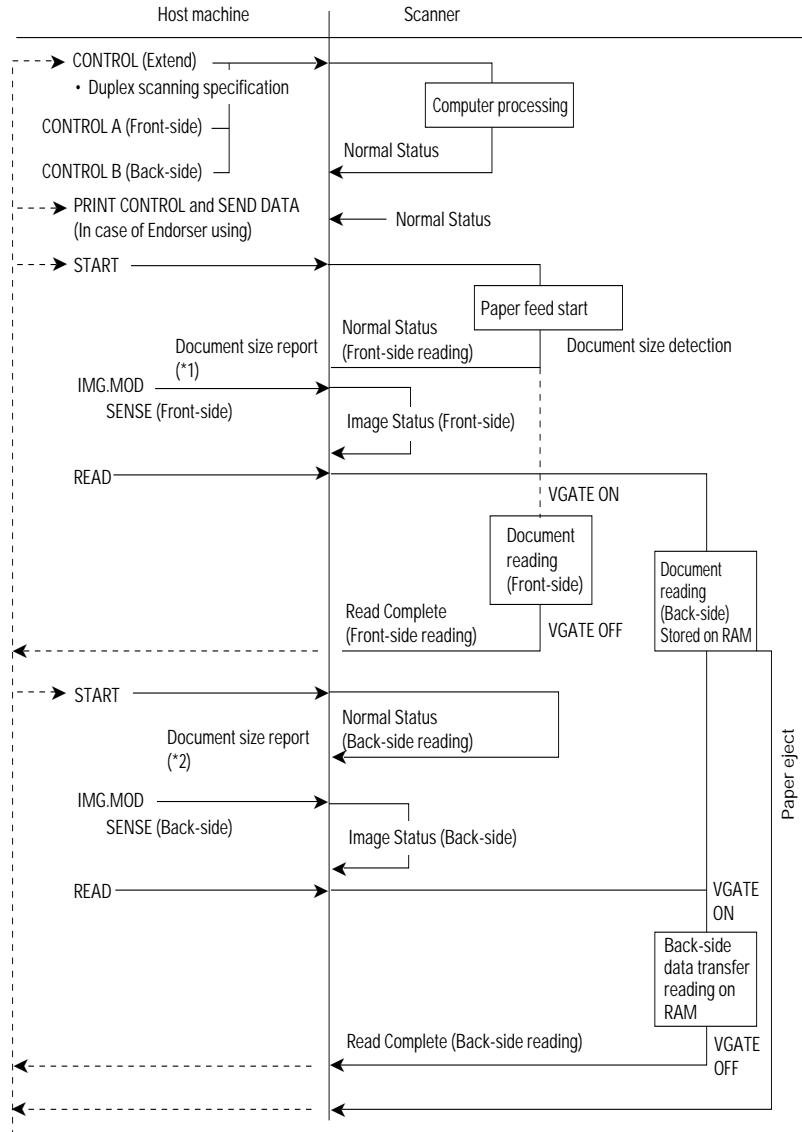

-
- ① The CONTROL command can be issued more than once.
 - ② The document size of *2 becomes the same as that reported by *1.
 - ③ No CONTROL command must be issued between a READ command for the front-side and a START command for the back-side. Any CONTROL command issued during this period is invalid. If a CONTROL command must be issued, terminate the scanning sequence once by issuing a CLEAR command. Issuing the CLEAR command cause the document to be ejected.
 - ④ The IMAGE MODE SENSE command need not always be issued.

Figure 3.7 Command/response sequences for the read operation (1)

Manual start mode duplex reading (ADF)

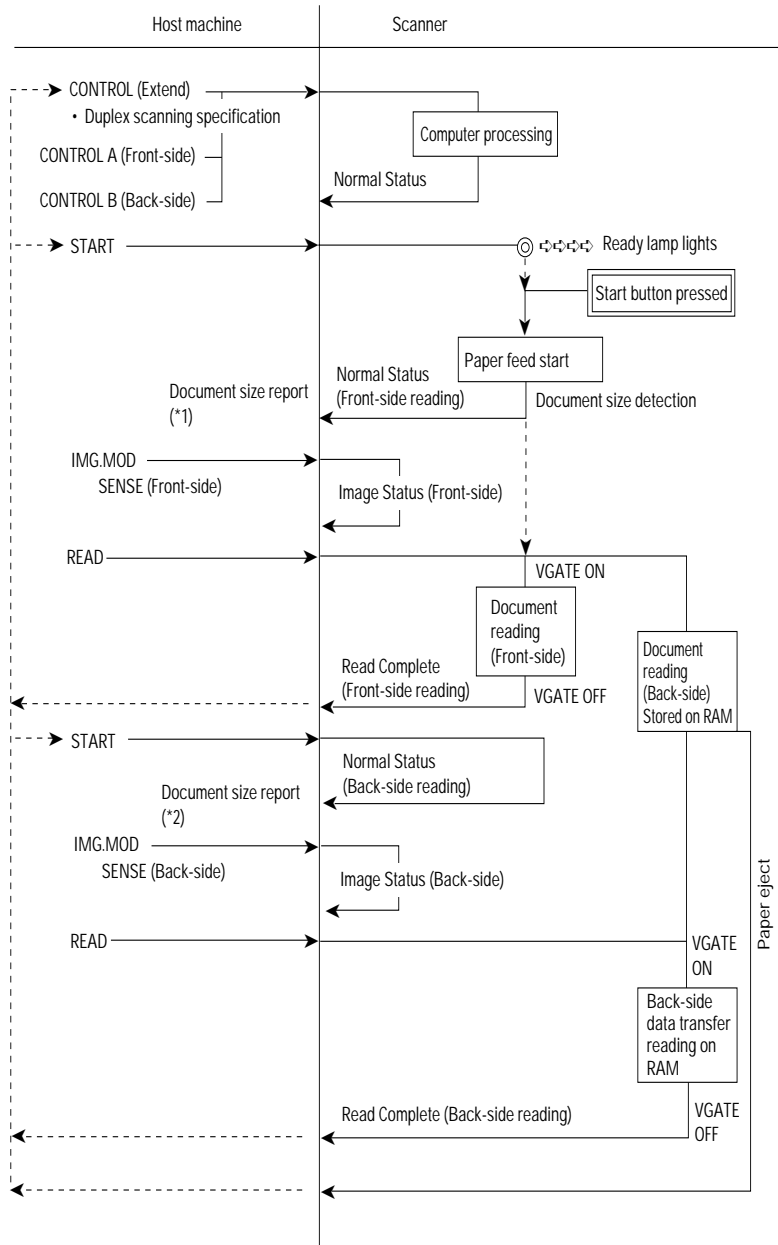

INTERFACE
SPECIFICATIONS

-
- ① The CONTROL command can be issued more than once.
 - ② The document size of *2 becomes the same as that reported by *1.
 - ③ No CONTROL command must be issued between a READ command for the front-side and a START command for the back-side. Any CONTROL command issued during this period is invalid. If a CONTROL command must be issued, terminate the scanning sequence once by issuing a CLEAR command. Issuing the CLEAR command cause the document to be ejected.
 - ④ The IMAGE MODE SENSE command need not always be issued.

Figure 3.8 Command/response sequences for the read operation (2)

Manual mode and duplex reading

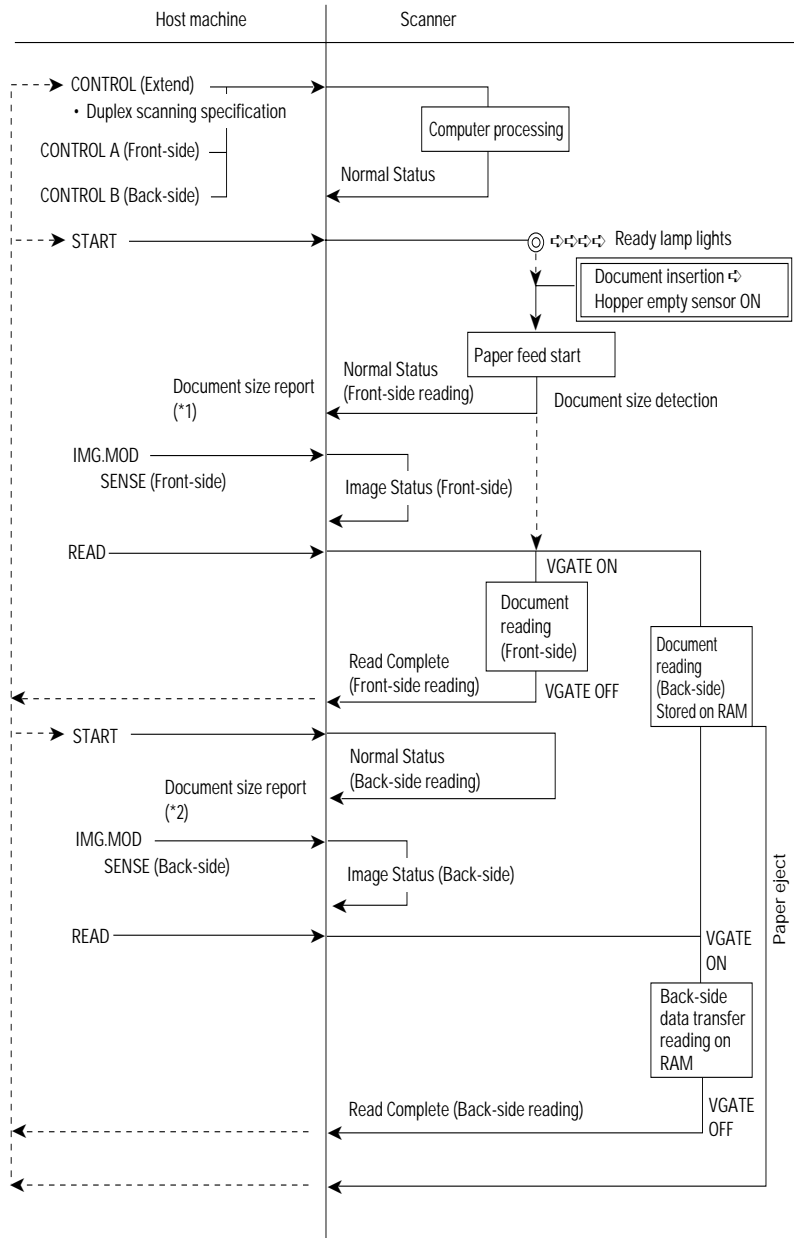

INTERFACE SPECIFICATIONS

-
- ① The CONTROL command can be issued more than once.
 - ② The document size of *2 becomes the same as that reported by *1.
 - ③ No CONTROL command must be issued between a READ command for the front-side and a START command for the back-side. Any CONTROL command issued during this period is invalid. If a CONTROL command must be issued, terminate the scanning sequence once by issuing a CLEAR command. Issuing the CLEAR command cause the document to be ejected.
 - ④ The IMAGE MODE SENSE command need not always be issued.
 - ⑤ When a START command is received in the manual insertion mode, the Ready lamp lights whether the scanning start specification is "Operator Panel" or "Host". The manual document insertion is awaited. When the Hopper Empty sensor is covered with a document, the scanner starts picking and transporting the document and returns "Normal Status".

Figure 3.9 Command/response sequences for the read operation (3)

Command/response correspondence

Response Command	Normal					Abnormal		
	Ready	Normal Status	Read Complete	Image Status	Unit Status	Operation Error	Temporary Error	Equipment Error
CLEAR	①					②		③
CONTROL		④				⑤		
IMAGE CTL		④				⑤		
START		⑥				⑧	⑨	⑭
READ			⑦			⑧	⑨	⑩
SENSE		⑪				⑫	⑬	⑭
RETURN SENSE		⑮				⑧		⑭
IMG.MODE SNS				④		⑧		⑭
INQUIRY					④	⑤		
SEND DITHER		④				⑤		
PRINT CONTROL		⑥				⑧		
SEND DATA		⑥				⑧		

- ① Initialization was completed.
- ② The command was destroyed by a transmission error.
- ③ Equipment abnormality was detected during initialization.
- ④ Command processing enabled normally.
- ⑤ The command was destroyed due to an operation error or transmission error.
- ⑥ Command processing enabled normally.
- ⑦ Reading operation enabled normally.
- ⑧ The command was destroyed because a sequence error or transmission error was detected.
- ⑨ Jam, hopper empty, or upper transport unit open detected.

-
- ⑩ Equipment abnormality was detected during read operation.
 - ⑪ Answer when no error was generated.
 - ⑫ The command was destroyed due to a transmission error.
 - ⑬ Paper jam not yet recovered.
 - ⑭ A device fault has been detected. (The fault has already been reported by the last CLEAR or READ commands)
 - ⑮ Return operation was completed normally.

Command/ Response Timing Chart

These timing charts are in the normal sequence at connector pins of the scanner. In these charts, STB, PB and SPB mean start bit, parity bit, and stop bit respectively.

Figure 3.10 to Figure 3.15 shows the timing chart for each command.

Figure 3.10 CLEAR command sequence

Figure 3.11 CONTROL command sequence

Figure 3.12 START command sequence

Figure 3.13 READ command sequence

Figure 3.14 SENSE command sequence

Figure 3.15 RETURN SENSE command sequence

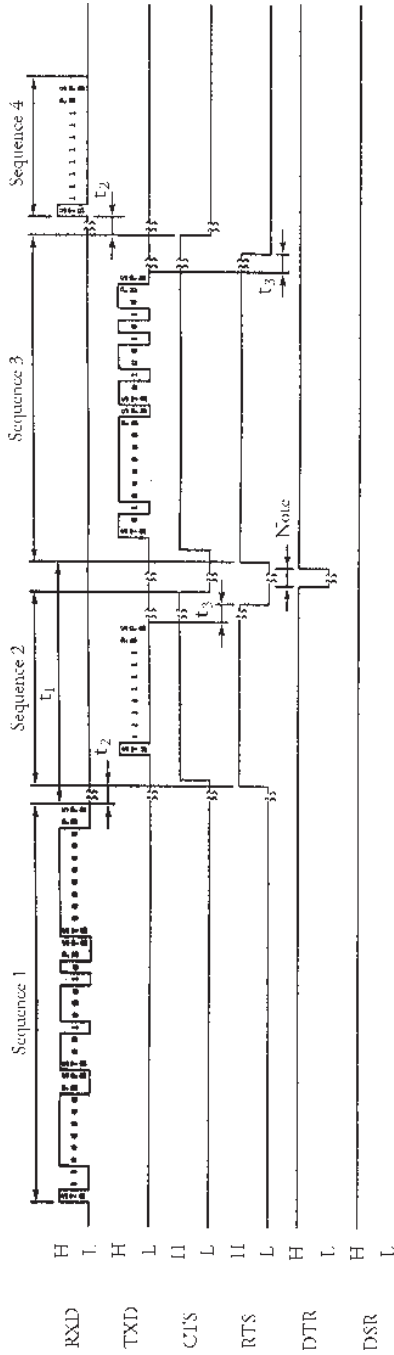

t_1 : More than 1 word length (changed by data transfer rate)

t_2 : Less than 500 ms

t_3 : Less than 5 s

Sequence 1: The host computer sends the CLEAR command to the scanner.

X'03', '44', '00'

Sequence 2: ACK for the CLEAR command is sent to the host computer.

X'FF'

Sequence 3: Response for the CLEAR command is sent to the host computer.

X'02', '52'

Sequence 4: ACK for the response (issued at Sequence 3) is sent to the scanner.

X'FF'

Note: During the CLEAR command execution, DTR signal takes low level.

Figure 3.10 CLEAR command sequence

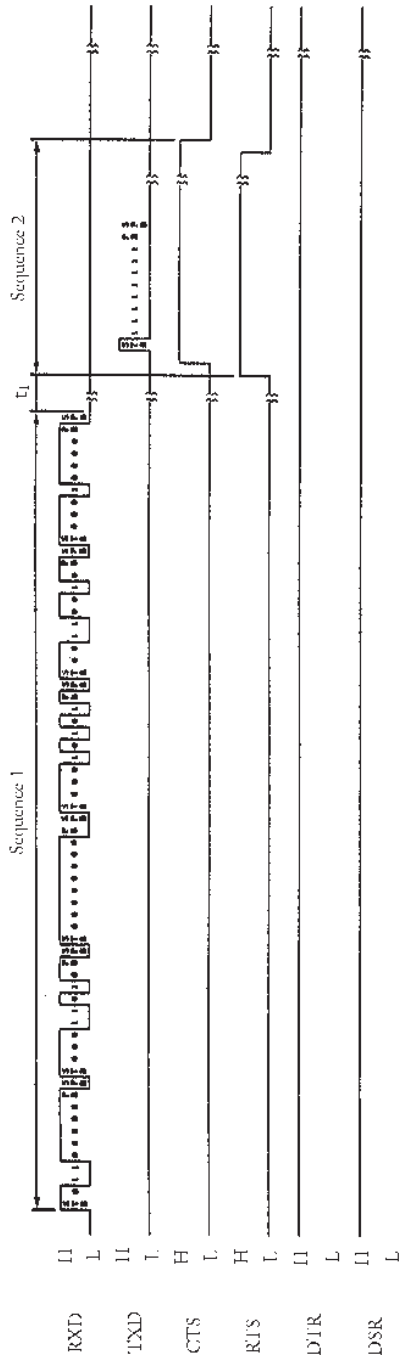

t_1 : Less than 500 ms

t_2 : More than 1 word length

Sequence 1: The host computer sends the CONTROL command to the scanner.

X'06', '58', '00', 'A8', '4C', '08'

Sequence 2: ACK for the CONTROL command is sent to the host computer.
X'FF'

Figure 3.11 CONTROL command sequence (1/4)

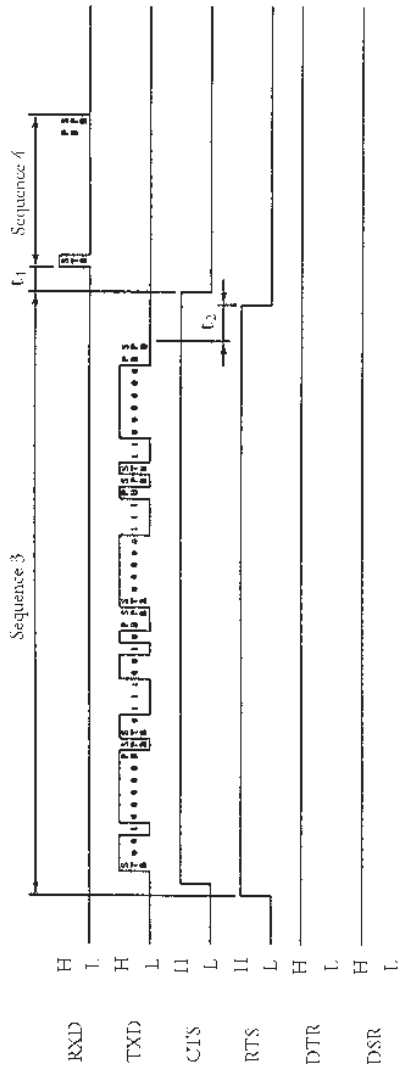

t_1 : Less than 500 ms

t_2 : More than 1 word length

Sequence 3: Response for the CONTROL command to the host computer.

X'04', '4E', 'E0', '03'

Sequence 4: ACK for the response (issued at Sequence 3) is sent to the scanner.
X'FF'

Figure 3.11 CONTROL command sequence (2/4)

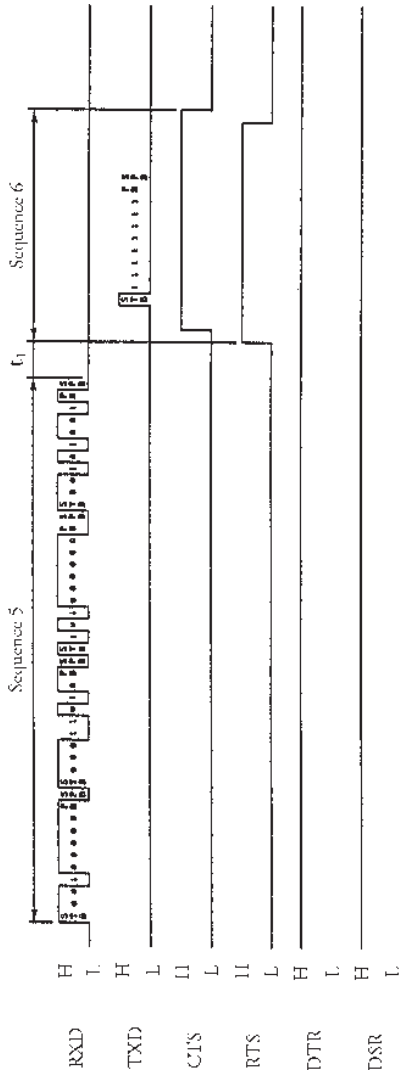

t_1 : Less than 500 ms

t_2 : More than 1 word length

Sequence 5: The host computer sends the CONTROL command to the scanner again.
 X'04', '58', '05', '94'

Sequence 6: ACK for the CONTROL command is sent to the host computer.
 X'FF'

Figure 3.11 CONTROL command sequence (3/4)

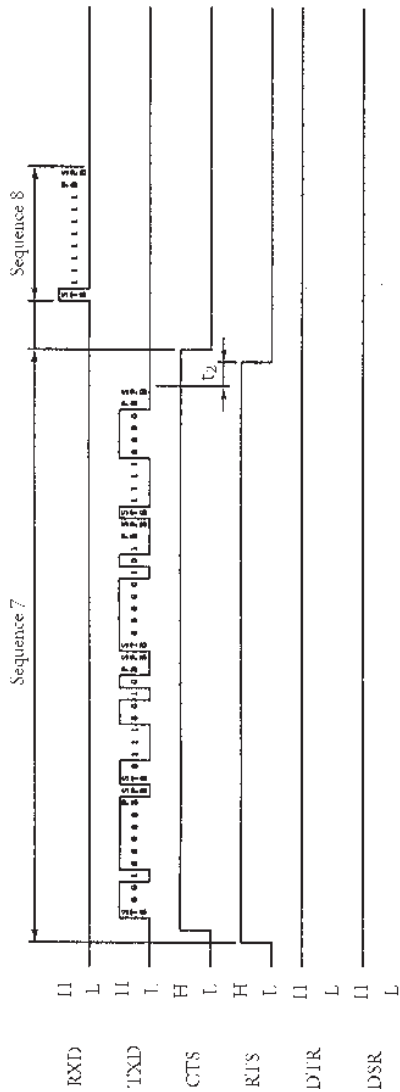

t₁: Less than 500 ms

t₂: More than 1 word length

Sequence 7: Response for the CONTROL command (Issued at Sequence 5) is sent to the host computer.

X'04', '4E', 'E0', '03'

Sequence 8: ACK for the response (issued at Sequence 7) is sent to the scanner.

X'FF'

Figure 3.11 CONTROL command sequence (4/4)

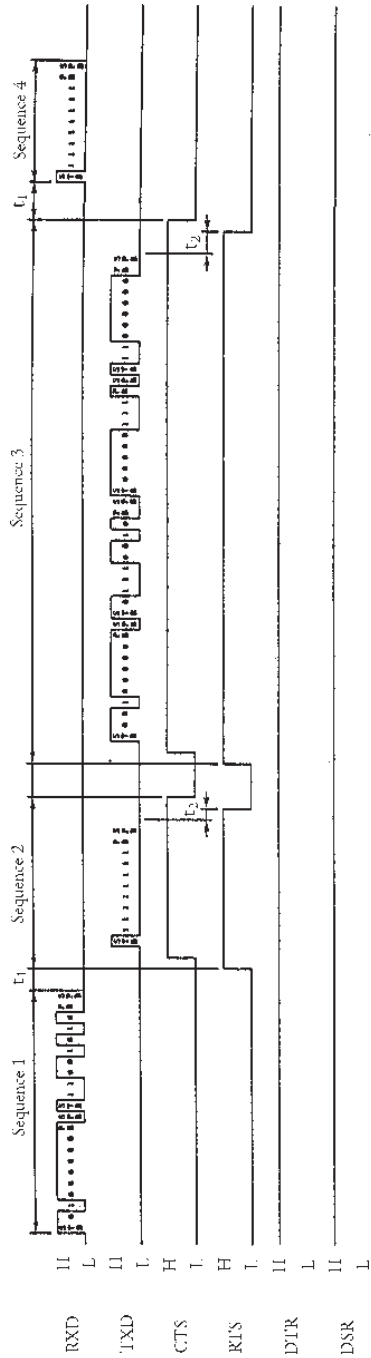

t_1 : Less than 500 ms

t_2 : More than 1 word length

Sequence 1: The host computer sends START command to the scanner.
X'02', '53'

Sequence 2: ACK for the START command is sent to the host computer.
X'FF'

Sequence 3: Response for the START command is sent to the host computer.
X'04', '4E', 'E0', '03'

Sequence 4: ACK for the response (issued at Sequence 3) is sent to the host computer.

Figure 3.12 START command sequence

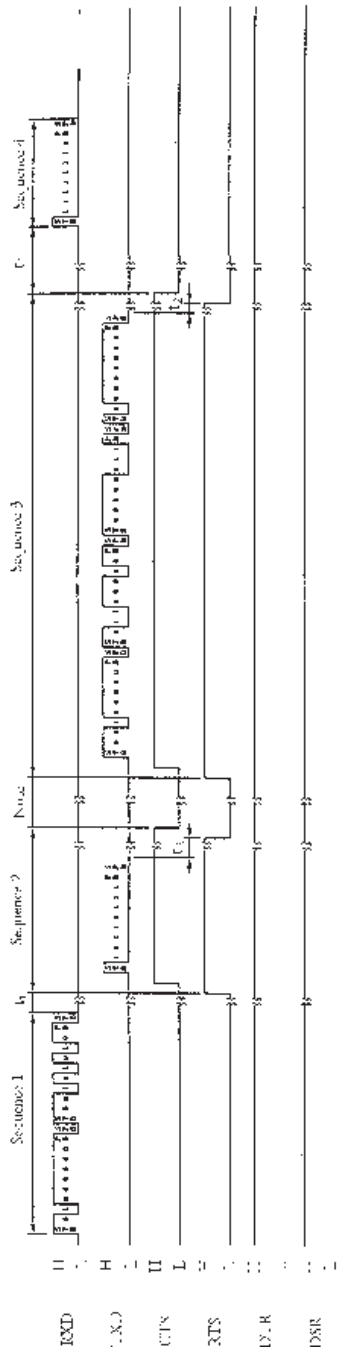

t_1 : Less than 500 ms

t_2 : More than 1 byte

Sequence 1: The host computer send the READ command to the scanner.
X'02', '5A'

Sequence 2: ACK for the READ command is sent to the host computer.
X'FF'

Sequence 3: Response for the READ command (read complete) is sent to the scanner.
X'04', '46', 'E0', '01'

Sequence 4: ACK for the read complete is sent to the scanner.

Note: Expect issuing read complete, the RTS signal is inhibitory taking low level.

Figure 3.13 READ command sequence

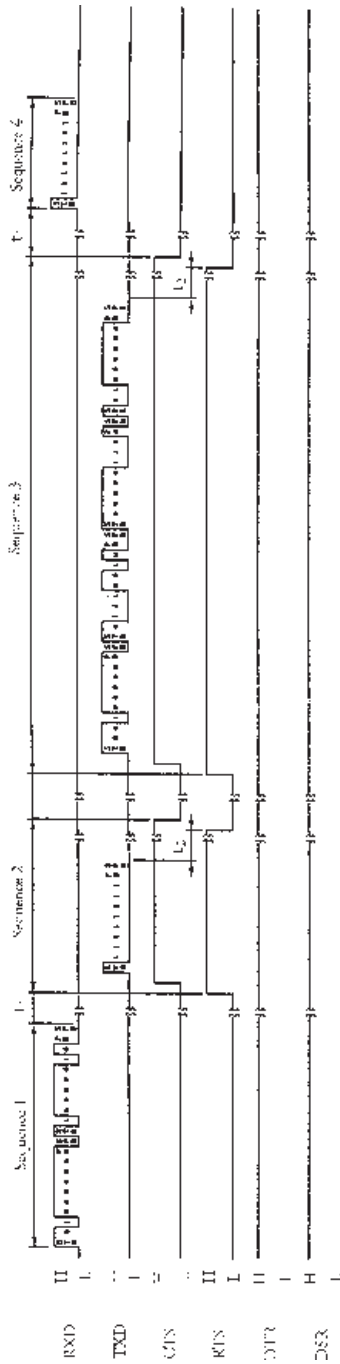

t_1 : Less than 500 ms

t_2 : 1 byte

Sequence 1: The host computer sends the SENSE command to the scanner.
X'02', '42'

Sequence 2: ACK for the SENSE command is sent to the host computer.
X'FF'

Sequence 3: Response for the SENSE command is sent to the host computer.
X'04', '4E', 'E0', '03'

Sequence 4: ACK for the response (issued at Sequence 3) is sent to the scanner.
X'FF'

Figure 3.14 SENSE command sequence

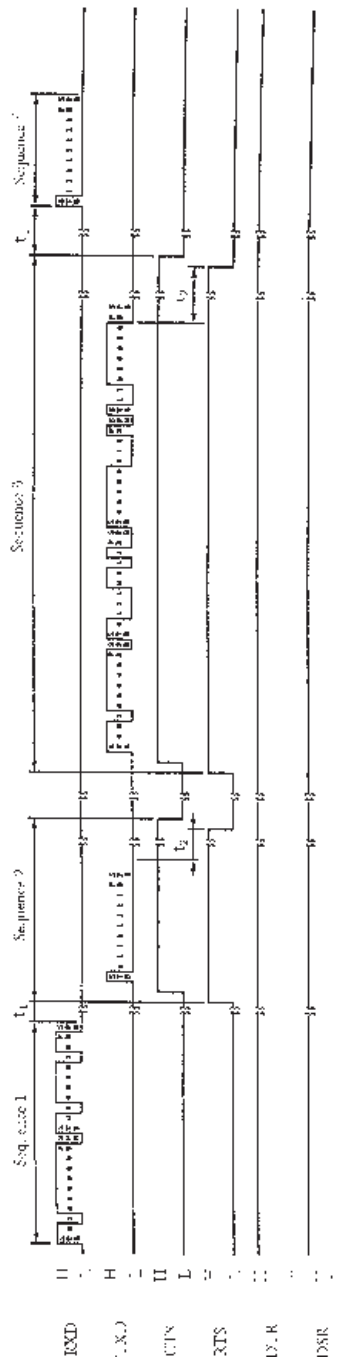

t_1 : Less than 500 ms

t_2 : More than 1 word length

Sequence 1: The host computer sends the RETURN SENSE command to the scanner.

X'02', '42'

Sequence 2: ACK for the RETURN SENSE command is sent to the host computer.

X'FF'

Sequence 3: Response for the RETURN SENSE command is sent to the host computer.

X'04', '4E', 'E0', '01'

Sequence 4: ACK for the response (issued at Sequence 3) is sent to the scanner.

X'FF'

Figure 3.15 RETURN SENSE command sequence

BASIC OPERATION

This chapter provides power switch operation, operator panel arrangement and functions, messages, and replacement of consumables.

Power Switch Operation

The power switch is located at the right side of the scanner.

Figure 4.1 shows switch location.

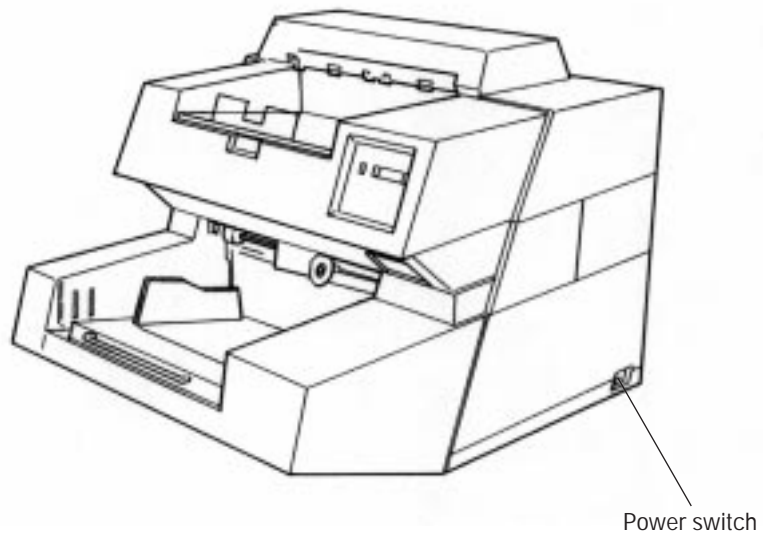
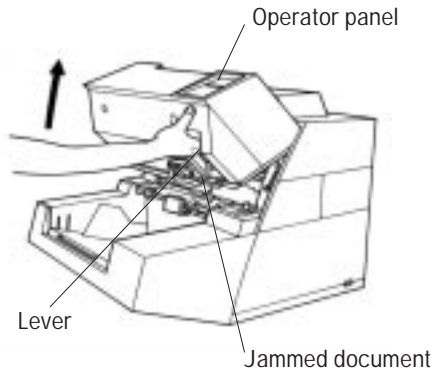

Figure 4.1 Power switch location

Opening the Upper Transport Unit



- ① Lift the lever below the operator panel to open the upper transport unit from under.

WARNING

Make sure that the upper transport unit is engaged in the "LIFT-up" position on the "LIFT-up" latch.

Closing the Upper Transport Unit

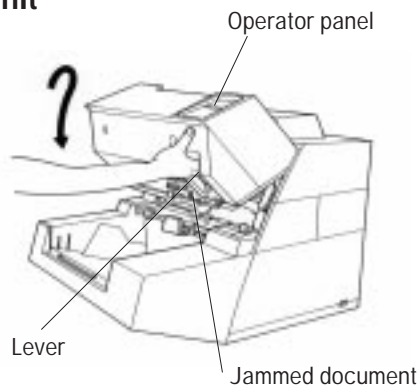

- ① Lift-up the upper transport unit with both of your hands to release the "LIFT-up" latch and then to lower down the upper transport unit with your hands.

WARNING

Before lowering down the unit, make sure that the area between the main machine and the upper transport unit is clear of all objects and fingers.

NOTICE

Press the upper transport unit with both hands to secure the lock.

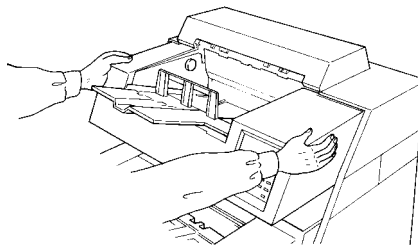

Operator Panel Arrangement and Functions

Operator panel arrangement

The operator panel is located at the front right on the front of the scanner. The panel consists of an LCD display (24 characters x 2 lines), LEDs and buttons.

Figure 4.2 shows arrangement of the operator panel.

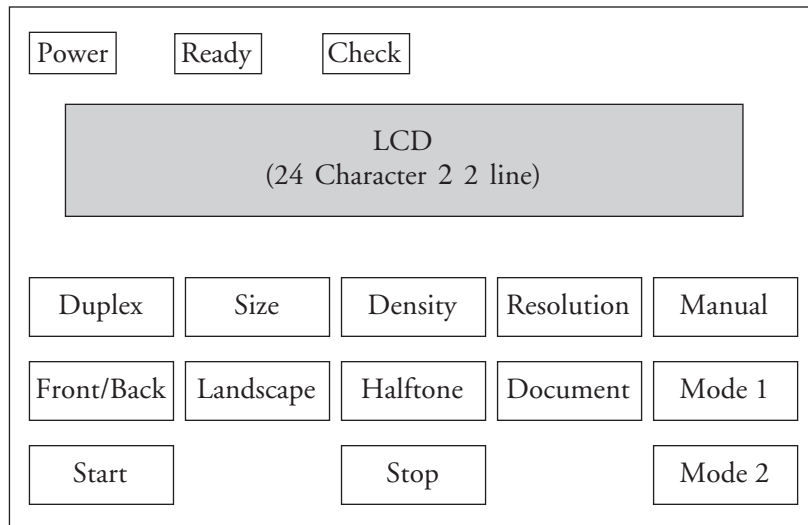

BASIC
OPERATION

Figure 4.2 Operator panel arrangement

Operator panel functions

The operator panel has 13 buttons and 3 LEDs.

Table 4.1 lists button functions, and Table 4.2 lists LED function.

Table 4.1 Button functions

Button name	Function
Start	When the Ready lamp is lit in the manual start mode, pressing this button starts a reading operation.
Stop	Pressed during reading The reading operation immediately stops and the document under transport is ejected to the stacker. A picked document if any is ejected to the stacker. The hopper table is lowered to the bottom. Pressed during setting of the reading mode The display returns to the initial screen. Pressed during waiting for Hopper Timer The Hopper table is lowered to the bottom. Pressed during displaying the initial screen The abrasion counter is displayed. Pressed during occurring the temporary error. The temporary error is recovered.
Duplex	Toggles the LCD screen between simplex and duplex reading .
Front/Back	Toggles the LCD screen between front-side and back-side for reading.
Size	Sets the document size.
Density	Sets the scanning density.
Resolution	Sets the scanning resolution.
Manual	Sets the manual mode. Pressing this button lifts the hopper table to the level for manual mode. Pressing the button again releases the mode and lowers the hopper table to the bottom.
Landscape	Sets the document scan direction to the portrait or landscape mode.
Halftone	Sets whether to execute halftone processing (dither or error diffusion) and also automatic separation processing (dither or error diffusion if the image processing option is installed).

Table 4.1 Button functions (Continued)

Button name	Function
Document	Sets the document type (photograph or linedrawing).
Mode 1	Activates the setup mode. (See Appendix B)
Mode 2	Activates the maintenance mode. (*1)

*1: See maintenance manual for details.

Table 4.2 LEDs function

Indicator	Color	Function
Power	Green	Lights to indicate the power is on.
Ready	Green	Lights when the image scanner becomes ready to read a document in the manual mode and manual start mode. This indicator turns off when the Start button is pressed to read a document.
Check	Yellow	Lights if a equipment error occurs. An error message is displayed on the LCD. This indicator blinks if a document is jammed in the ADF. This indicator turns off when the jammed documents are removed from the ADF and the upper transport unit is closed.

LCD display

The scanner is provided with simplex and duplex reading modes.

Simplex reading mode

The upper line (line 1) displays the current read mode for simplex reading.

The lower line (line 2) displays the modes set and messages when the buttons are pressed.

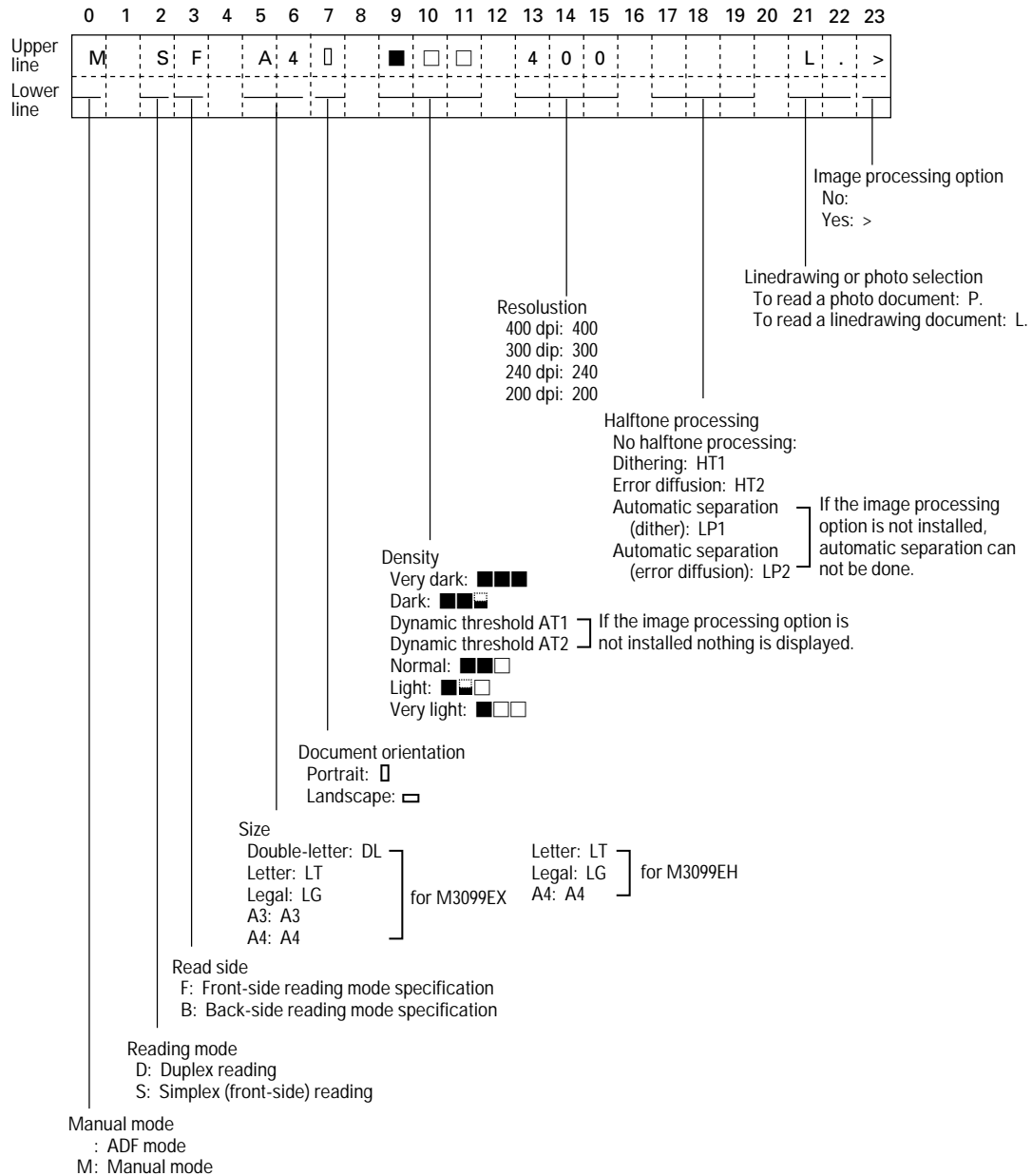

Duplex reading mode

The upper line (line 1) displays the current read mode for front-side reading.

The lower line (line 2) displays the current read mode for back-side reading.

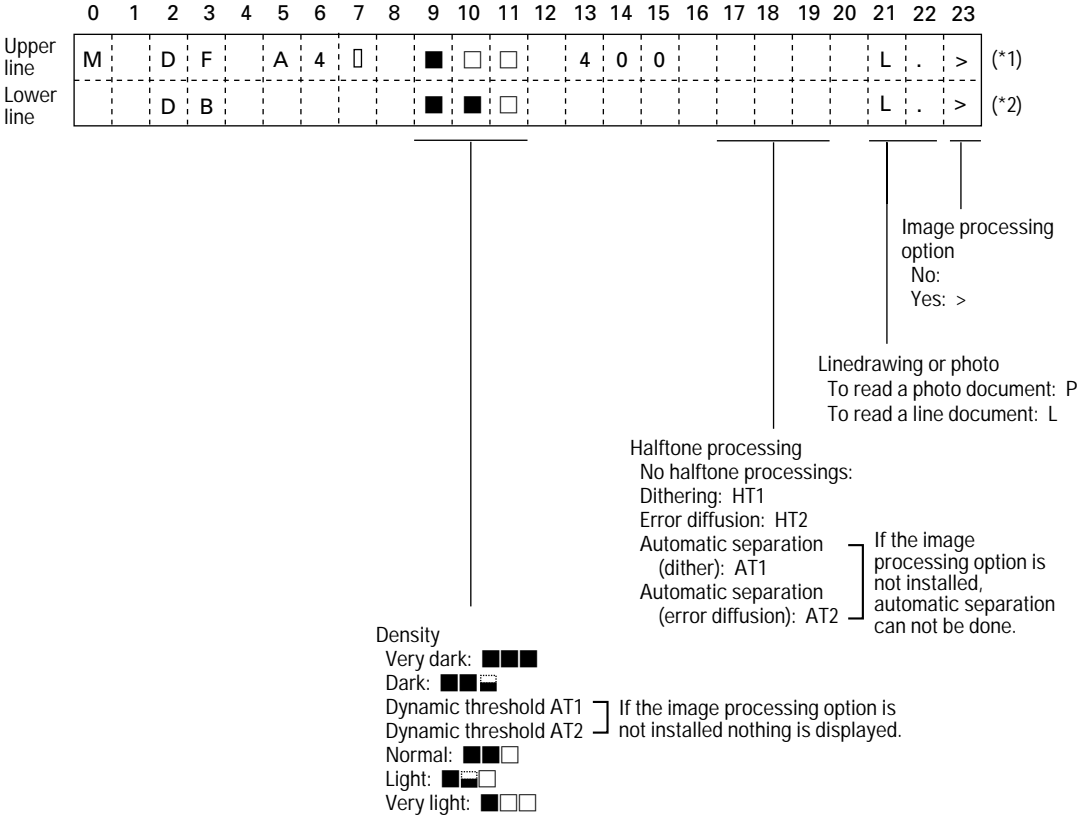

- *1: The upper line display messages are the same as those in the simplex reading mode.
- *2: For back-side reading, only the density, halftone processing, document selection, and image processing options can be specified. The other mode is the same as that for front-side reading.

The setup and messages for the pressed buttons are displayed on the bottom line for front-side reading and on the top line for back-side reading.

Button specification and reading mode setting

The button specifications and setup details are explained each of the simplex (front-side), duplex (front-side) and duplex (back-side) reading modes. The three modes are switched over with the Duplex and Front/Back buttons as follows:

[Duplex] button

This button is used to select simplex or duplex document reading. Pressing the button toggles the display between the initial screens of the simplex and duplex reading modes.

<Initial screen of the simplex reading mode>

0	1	2	3	4	5	6	7	8	9	10	11	12	13	14	15	16	17	18	19	20	21	22	23
	S	F		A	4				■	□	□		4	0	0					L	.	.	>

↑ ↓ Duplex button pressed

<Initial screen of the duplex reading mode>

0	1	2	3	4	5	6	7	8	9	10	11	12	13	14	15	16	17	18	19	20	21	22	23
	D	F		A	4				■	□	□		4	0	0					L	.	.	>
	D	B							■	□	□									L	.	.	>

[Front/Back] button

This button is valid only in the duplex reading mode and to toggle the read side front or back.

“F” and “B” alternately blink for the setting of front or back-side.

<Initial screen of the duplex reading mode>

0	1	2	3	4	5	6	7	8	9	10	11	12	13	14	15	16	17	18	19	20	21	22	23
		D	F		A	4	□		■	□	□		4	0	0					L	.	>	
		D	B						■	□	□									L	.	>	

↓
Front/Back button pressed

<Screen 1>

0	1	2	3	4	5	6	7	8	9	10	11	12	13	14	15	16	17	18	19	20	21	22	23
		D	F		A	4	□		■	□	□		4	0	0					L	.	>	
		D	B						■	□	□									L	.	>	

(Blinking)

↑ ↓
Front/Back button pressed

<Screen 2>

0	1	2	3	4	5	6	7	8	9	10	11	12	13	14	15	16	17	18	19	20	21	22	23
		D	F		A	4	□		■	□	□		4	0	0					L	.	>	
		D	B						■	□	□									L	.	>	

(Blinking)

Simplex (front-side) reading mode

<Initial screen of the simplex reading mode>

0	1	2	3	4	5	6	7	8	9	10	11	12	13	14	15	16	17	18	19	20	21	22	23
		S	F		A	4	□		■	□	□		4	0	0					L	.	>	

[Size] button

Select a document size. When this button is pressed the lower line is displayed as shown in Screen 3. Each time this button on M3099EX is pressed, "DLT", "LT", "LG", "A3", or "A4" starts blinking in turn. And each time this button on M3099EH is pressed, "LT", "LG" or "A4" starts blinking in turn. The size displayed on the upper line changes accordingly.

<Screen 3>

	0	1	2	3	4	5	6	7	8	9	10	11	12	13	14	15	16	17	18	19	20	21	22	23
M3099EH			S	F	A	4	□		■	□	□			4	0	0						L	.	>
			S	i	z	e	;		L	T		L	G		A	4							□	

(Blinking)

	0	1	2	3	4	5	6	7	8	9	10	11	12	13	14	15	16	17	18	19	20	21	22	23
M3099EX			S	F	A	4	□		■	□	□			4	0	0						L	.	>
			S	i	z	e	;	D	L	T		L	T		L	G		A	3		A	4		□

(Blinking)

If the direction indicated on the upper line is "□" only "LT" or "A4" can be selected.

[Density] button











Selects a density for the read operation. When this button is pressed, the lower line is displayed as shown in Screen 4. Each time this button is pressed, the blinking part in the lower line changes, and the density indicated on the upper line changes according to the blinking part.

<Screen 4>

	0	1	2	3	4	5	6	7	8	9	10	11	12	13	14	15	16	17	18	19	20	21	22	23
			S	F	A	4	□		■	■	□			4	0	0						L	.	>
			D	e	n	.	:		■	■	■	□	□		A	T		(A	u	t	o)	2

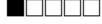
(Blinking)

The lower line is displayed as shown below. (See the beginning of this selection for the upper line.)

Lower line display		Description
Without image processing option	With image processing option	
 	 	Very dark
	Auto 1	Dark
	Auto 2	Dynamic threshold
  	  	Simplified dynamic threshold
		Normal
		Light
		Very light

Blinking order
↓

BASIC OPERATION

[Resolution] button

Selects a resolution for the read operation. When this button is pressed, the lower line is displayed as shown in Screen 5. Each time this button is pressed, "400", "300", "240", or "200" starts blinking in turn, and the resolution indicated on the upper line changes accordingly.

<Screen 5>

0	1	2	3	4	5	6	7	8	9	10	11	12	13	14	15	16	17	18	19	20	21	22	23
	S	F		A	4	□		■	□	□			4	0	0						L	.	>
			R	e	s	.	:	4	0	0		3	0	0		2	4	0		2	0	0	

(Blinking)

[Landscape] button (*1)

Specified whether reading is done in landscape or portrait mode. When this button is pressed, the lower line is displayed as shown in Screen 6. Each time this button is pressed, the blinking part changes in turn, and the mode indicated on the upper line changes accordingly.

*1: This button is available only for M3099EX.

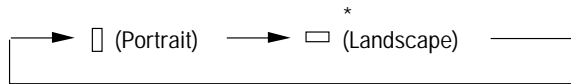

Note:

The landscape mode can be selected only when the document size is LT or A4.

<Screen 6>

	0	1	2	3	4	5	6	7	8	9	10	11	12	13	14	15	16	17	18	19	20	21	22	23
M3099EH		S	F		A	4	□	■	:	□	□		4	0	0						L	.	>	
	S	i	z	e	:		L	T		L	G		A	4								□		

(Blinking)

	0	1	2	3	4	5	6	7	8	9	10	11	12	13	14	15	16	17	18	19	20	21	22	23
M3099EX		S	F		A	4	□	■	:	□	□		4	0	0						L	.	>	
	S	i	z	e	:	D	L	T		L	T		L	G		A	3		A	4		□		

(Blinking)

[Half-tone] button

Specified whether to perform halftone processing (dither or error diffusion). When this button is pressed, the lower line is displayed as shown in Screen 7. Each time this button is pressed, the blinking part changes in turn, and the halftone indicated on the upper line changes accordingly.

<Screen 7>

0	1	2	3	4	5	6	7	8	9	10	11	12	13	14	15	16	17	18	19	20	21	22	23
	S	F	A	4	□	■	□	□	4	0	0			H	T	1	L	.	>				
	H	a	l	f	t	o	n	e	:	O	F	F		H	T	1	L	P					

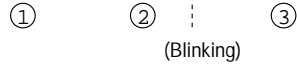

(Blinking)

Not displayed unless the image processing option is installed.

BASIC OPERATION

Blinking order	Display			Explanation
	①	②	③	
1	OFF blinking	HT1	LP1	Line Art (Halftone processing off)
2	OFF	HT1 blinking	LP1	
3	OFF	HT2 blinking	LP2	Halftone processing (error diffusion)
4	OFF	HT1	LP1 blinking	
5	OFF	HT2	LP2 blinking	Automatic separation (error diffusion)

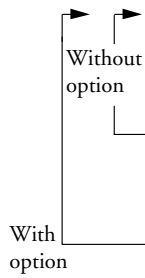

Not displayed unless the image processing option installed.

*1: Select one of these settings to read data such as photographs, illustration, or colored maps.

*2: If photographs and characters are mixed in a document, the characters are read clearly and the photographs are read in halftone. This setting is only available if the image processing option is installed.

[Document] button

Selects the type of document. When this button is pressed, the lower line is displayed as shown in Screen 8. Each time this button is pressed, "LINE" or "PHOTO" starts blinking in turns, and the document selection indication displayed on the upper line changes accordingly.

<Screen 8>

0	1	2	3	4	5	6	7	8	9	10	11	12	13	14	15	16	17	18	19	20	21	22	23	
	S	F	A	4	□	■	□	□	4	0	0	H	T	1	P
D O C . ; L . (L i n e)												P . (P h o t o)												

(Blinking)

Display	Explanation
P. (Photo)	For light adjustment or when there is a dark background color on the document select P. (Photo)
L. (Line)	Select this setting to read linedrawings.

[Manual] button

This button is used to set or release the manual mode.

Pressing this button displays <Screen 9>. The manual mode is set and the hopper goes up. Pressing the button again releases the manual mode and lowers the hopper to the bottom.

<Screen 9>

0	1	2	3	4	5	6	7	8	9	10	11	12	13	14	15	16	17	18	19	20	21	22	23
M	S	F	A	4	□	■	□	□	4	0	0	H	T	1	L

(Manual mode set)

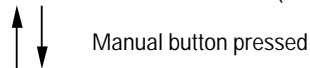

<Initial screen of the simplex reading mode>

0	1	2	3	4	5	6	7	8	9	10	11	12	13	14	15	16	17	18	19	20	21	22	23
	S	F	A	4	□	■	□	□	4	0	0	H	T	1	L

(Manual mode released)

Screen transition

<Initial screen of the simplex reading mode>

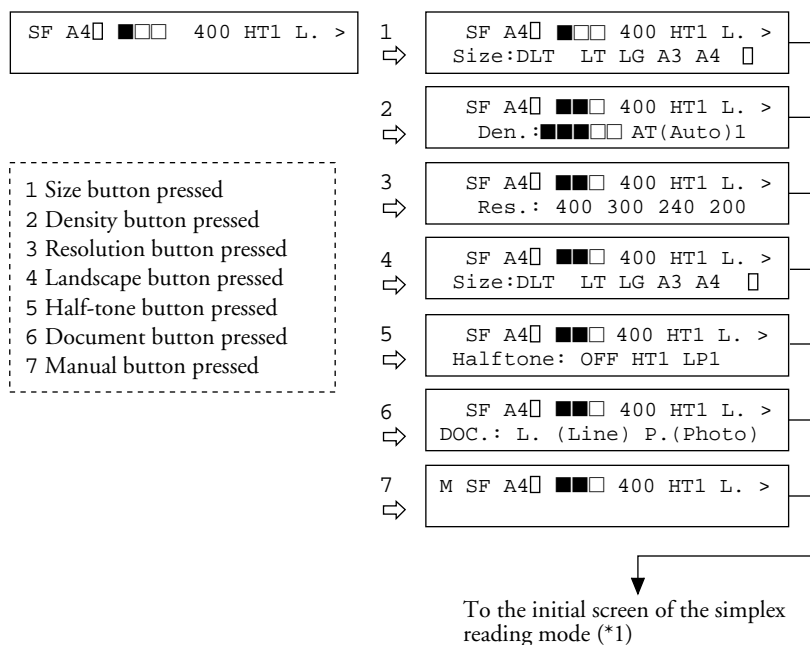

*1: Pressing the Stop button during reading mode setting returns the display to the initial screen of the simplex reading mode. Press the stop button then start the scan from the initial screen.

Duplex (front-side) reading mode

<Initial screen of the duplex reading mode>

0	1	2	3	4	5	6	7	8	9	10	11	12	13	14	15	16	17	18	19	20	21	22	23
	D	F		A	4	[]	[]	[]	[]	[]	[]	[]	4	0	0						L	.	>
	D	B							[]	[]	[]										L	.	>

[Size] button

This button is used to select a document size.

For details, see the explanation of <Screen 3>.

<Screen 10>

	0	1	2	3	4	5	6	7	8	9	10	11	12	13	14	15	16	17	18	19	20	21	22	23
M3099EH			D	F	A	4	□		■	□	□			4	0	0					L	.	.	>
		S	i	z	e	:		L	T		L	G		A	4								□	

(Blinking)

	0	1	2	3	4	5	6	7	8	9	10	11	12	13	14	15	16	17	18	19	20	21	22	23
M3099EX			D	F	A	4	□		■	□	□			4	0	0					L	.	.	>
		S	i	z	e	:	D	L	T		L	T		L	G		A	3		A	4		□	

(Blinking)

[Density] button

This button is used to select a scanning density.

For details, see the explanation of <Screen 4>.

<Screen 11>

	0	1	2	3	4	5	6	7	8	9	10	11	12	13	14	15	16	17	18	19	20	21	22	23	
		D	F	A	4	□				■	■	□			4	0	0					L	.	.	>
		D	e	n	.	:		■	■	■	□	□			A	T	(A	u	t	o)	1		

(Blinking)

[Resolution] button

This button is used to select a scanning resolution.

For details, see the explanation of <Screen 5>.

<Screen 12>

	0	1	2	3	4	5	6	7	8	9	10	11	12	13	14	15	16	17	18	19	20	21	22	23
		D	F	A	4	□				■	□	□		4	0	0					L	.	.	>
		R	e	s	.	:	4	0	0		3	0	0		2	4	0		2	0	0			

(Blinking)

[Landscape] button

This button is used only for M3099EX to select document reading operation in the portrait or landscape mode.

For details, see the explanation of <Screen 6>.



Note:

The landscape mode can be selected only when the document size is LT or A4.

<Screen 13>

	0	1	2	3	4	5	6	7	8	9	10	11	12	13	14	15	16	17	18	19	20	21	22	23
M3099EH		D	F	A	4				■					4	0	0						L	.	>
	S	i	z	e	:		L	T		L	G		A	4										

(Blinking)

	0	1	2	3	4	5	6	7	8	9	10	11	12	13	14	15	16	17	18	19	20	21	22	23
M3099EX		D	F	A	4				■					4	0	0						L	.	>
	S	i	z	e	:	D	L	T		L	T		L	G		A	3		A	4				

(Blinking)

[Halftone] button

This button is used to select whether or not to perform halftone (dither or error diffusion) processing.

For details, see the explanation of <Screen 7>.

<Screen 14>

	0	1	2	3	4	5	6	7	8	9	10	11	12	13	14	15	16	17	18	19	20	21	22	23
		D	F	A	4				■					4	0	0		H	T	1		L	.	>
	H	a	l	f	t	o	n	e	:	O	F	F		H	T	1		L	P					



(Blinking)

Not displayed unless the image processing option is installed.

[Document] button

This button is used to select a line drawing or photograph reading document.

For details, see the explanation of <Screen 8>.

<Screen 15>

0	1	2	3	4	5	6	7	8	9	10	11	12	13	14	15	16	17	18	19	20	21	22	23	
	D	F		A	4	□		■	□	□		4	0	0		H	T	1		P	.	>		
D	O	C	.	:			L	.	(L	i	n	e)		P	.	(P	h	o	t	o)

(Blinking)

[Manual] button

This button is used to set or release the manual mode.

For details, see the explanation of <Screen 9>.

<Screen 16>

0	1	2	3	4	5	6	7	8	9	10	11	12	13	14	15	16	17	18	19	20	21	22	23
M	D	F		A	4	□		■	□	□		4	0	0		H	T	1		L	.	>	
	D	B						■	□	□											L	.	>

(Manual mode set)



Manual button pressed

<Initial screen of the duplex reading mode>

0	1	2	3	4	5	6	7	8	9	10	11	12	13	14	15	16	17	18	19	20	21	22	23
	D	F		A	4	□		■	□	□		4	0	0							L	.	>
	D	B						■	□	□											L	.	>

(Manual mode released)

Screen transition

<Initial screen of the duplex reading mode>

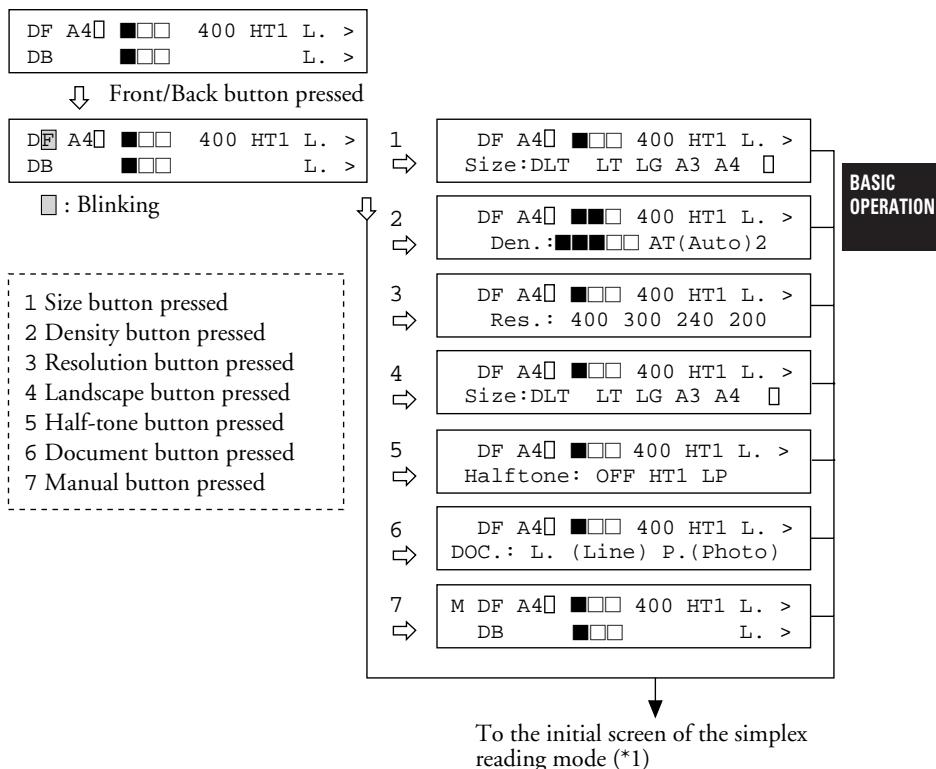

*1: Pressing the Stop button during reading mode setting returns the display to the initial screen of the duplex reading mode. Press the stop button then start the scan from the initial screen.

Duplex (back-side) reading mode

<Initial screen of the duplex reading mode>

0	1	2	3	4	5	6	7	8	9	10	11	12	13	14	15	16	17	18	19	20	21	22	23
		D	F		A	4			■	□	□			4	0	0					L	.	>
		D	B						■	□	□										L	.	>

In this mode, the Density, Half-tone, and Document buttons are effective.

[Density] button

This button is used to select a reading density.

For details, see the explanation of <Screen 4>.

<Screen 17>

									(Blinking)														
		D	e	n	.	:	■	■	■	□	□		A	T	(A	u	t	o)	2		
		D	B				■	■	■	□	□										L	.	>

[Halftone] button

This button is used to select whether or not to perform the halftone (dither or error diffusion) processing.

For details, see the explanation of <Screen 7>.

<Screen 18>

		H	a	l	f	t	o	n	e	:	O	F	F		H	T	1		L	P			
		D	B						■	□	□							H	T	1	L	.	>

Not displayed unless the image processing option is installed.

(Blinking)

1 2 3

[Document] button

This button is used to select a line images or photograph reading document.

For details, see the explanation of <Screen 8>.

<Screen 19>

															(Blinking)								
0	1	2	3	4	5	6	7	8	9	10	11	12	13	14	15	16	17	18	19	20	21	22	23
D	O	C	.	:		L	.	(L	i	n	e)		P	.	(P	h	o	t	o)
		D	B						■	□	□										P	.	>

Screen transition

<Initial screen of the duplex reading mode>

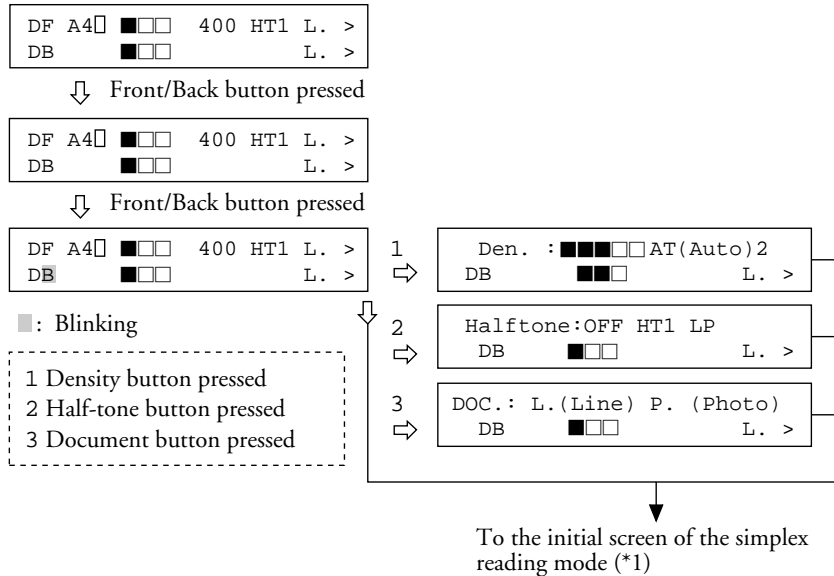

*1: Pressing the Stop button during reading mode setting returns the display to the initial screen of duplex reading mode. Press the stop button then start the scan from the initial screen.

[Start]/[Stop] button

Reading is started or stopped using the Start and Stop buttons as follows:

[Start] button

Read operation can be started in either manual or automatic start mode. To start reading in manual start mode, press this button while the ready indicator is lit. (*1)

*1: Make sure that the LCD is initial screen of simplex or duplex reading mode. If not press Stop button once, then press Start button.

Manual start mode: Reading is started by the Start button.

Automatic start mode: Reading is started by a command from the host machine.

[Stop] button

This button is effective regardless of whether the scanner is in manual or automatic mode. Press this button to stop the read operation.

During reading: Reading immediately stops and the document being fed are ejected to the stacker.
The hopper table is lowered to the bottom.

Before reading: A prepicked document if any is ejected to the stacker. The button works only when a document is picked.
The hopper table is lowered to the bottom.

Note: If a document which is not picked remain in front of ADF.
Please set the document on the hopper again.

Operation display

Device statuses are indicated by the following messages:

<Power-on>

0	1	2	3	4	5	6	7	8	9	10	11	12	13	14	15	16	17	18	19	20	21	22	23	
				W	a	r	m	i	n	g	-	u	p			N	o	w	!	!				

Waiting until the lamps are ready to read.

If it is ready, the screen changes to the initial screen of the simplex or duplex reading mode.

<Warning>

	0	1	2	3	4	5	6	7	8	9	10	11	12	13	14	15	16	17	18	19	20	21	22	23
Upper line		X	X		X	X	X		X	X	X		X	X	X						X	X	X	
Lower line									I	N	K		E	M	P	T	Y							

The upper line displays the current read mode for front-side reading. The lower line is blinking and displays the ink empty of print head after the scanning operation.

This warning display will be reset, when the covers are opened, or [STOP] is pressed, or Start command is issued. The operator must change the print head and reset the life counter. (See Appendix A)

<Paper counter>

The counter of reading paper is displayed in a batch of the reading operation.

Example of simplex reading

0	1	2	3	4	5	6	7	8	9	10	11	12	13	14	15	16	17	18	19	20	21	22	23	
		S	F		A	4	□	■	□	□		4	0	0							L	.	>	
																					X	X	X	

Reading counter

In following case, the display of counter is deleted.

- The next Start Command is issued.
- The valid switches are pressed.
- The error is cleared.

The abrasioin counter is displayed after pressing [STOP] SW in the initial screen.

0	1	2	3	4	5	6	7	8	9	10	11	12	13	14	15	16	17	18	19	20	21	22	23	
		S	F		A	4	:	□	■	□	□		4	0	0						L	.	>	
																			X	X	X	X	X	X

Abrasion counter

In following case, the display of counter is deleted.

- The next Start Command is issued.
- The valid switches are pressed.
- The error is cleared.

Abrasion counter is not displayed if [STOP] SW is pressed in blinking. This counter can be reset to zero by the procedure shown in section B.3.6.

<IPC II pre-set mode>

When IPC II pre-set mode is set, an asterisk (*) is displayed. The method of IPC II pre-set mode is shown in setup mode.

Screen of the simplex reading mode

0	1	2	3	4	5	6	7	8	9	10	11	12	13	14	15	16	17	18	19	20	21	22	23
		S	F		A	4	:	□	■	□	□		4	0	0						L	.	>
*																							

Screen of the duplex reading mode

0	1	2	3	4	5	6	7	8	9	10	11	12	13	14	15	16	17	18	19	20	21	22	23
		S	F		A	4	:	□	■	□	□		4	0	0						L	.	>
*		D	F						■	□	□										L	.	>

Buzzer Functions

The scanner has a buzzer to let users know the error of the scanner. The buzzer functions are shown in Table 4.3.

Table 4.3 Buzzer functions

Error	Function
Equipment error	Sounds during 3 seconds. The buzzer turns off when a button is pressed or power is turned off. Even if a button is pressed, the scanner continues to display the error.
Temporary error	Sounds during 3 seconds with 0.5 second interval. The buzzer turns off when a button is pressed or power is turned off. Even if a button is pressed, the scanner continues to display the error.

Buzzer function can be set on or off by the procedure in section B3 of Appendix B.

Message List

Table 4.4 lists the messages indicating scanner statuses, temporary errors, and equipment errors.

Table 4.4 Messages

Classification	LCD display
Operation display	Warming-up Now!!
Warning	INK EMPTY (*1)
Temporary errors	PAPER JAM
	HOPPER EMPTY
	COVER OPEN
	MISS PICK
	ROLLER UNIT NOT SET
	HOPPER OVERLOAD
	PRINT HEAD NOT SET (*1)
PRINT HEAD ALARM (*1)	

Table 4.4 Messages (continued)

Classification	LCD display
Equipment errors	HOPPER ALARM
	TRANSPORT ALARM
	LAMP ALARM 1
	HEATER ALARM 1
	LAMP ALARM 2
	HEATER ALARM 2
	CCD UNIT ALARM 1
	CCD UNIT ALARM 2
	TEMP. ALARM
	FUSE ALARM PRINT
	RAM ALARM PRINT (*1)
	TIME-OUT ALARM PRINT (*1)
	HARDWARE ALARM

*1 This message is blinked only when the endorser option is used.

Loading Document

This section provides how to load documents.

When the LCD display on the operator panel has displayed “Hopper Empty”, supply documents as follows:

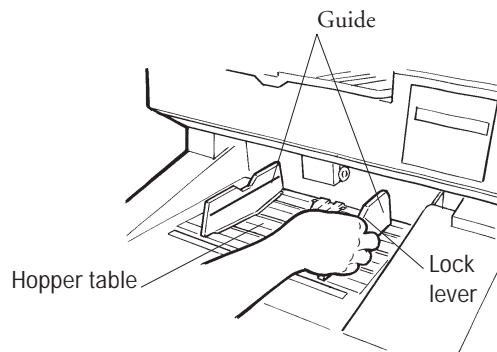

- ① Set the specified document width.

Hold the lock lever at the guide center on the right of the hopper table and move it horizontal to set the document width.

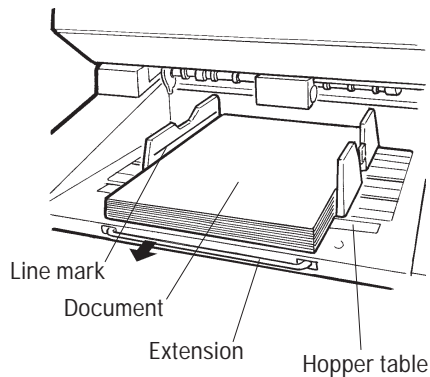

- ② Load a document read side face-up on the hopper table.

Note:

1. Be sure not to load documents higher than the line marked inside the guide on each side of the hopper table.
2. If the documents are too long, pull out the extension at the front of the hopper.

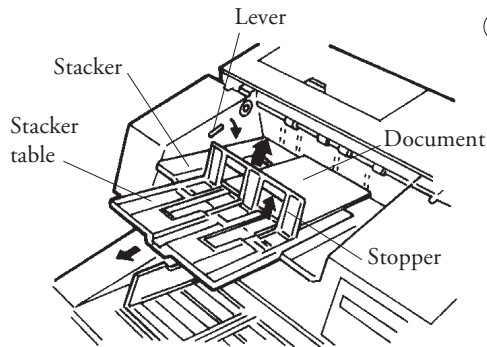

- ③ Adjust the stacker table to the document size.

Note:

Extend the stacker table and extension for long documents. Stand and extend the stopper up and also turn the lever in the stacker down for short documents.

If the scanner is 500 sheets hopper type, extend the stacker table for long documents. And also use stopper for small documents.

Load a document about 20 mm a part from the stopper.

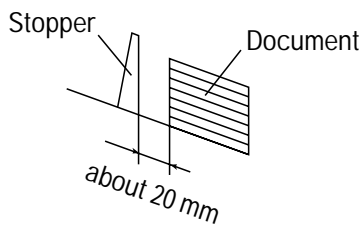

Lamp Replacement

The scanner has two lamps, one for front-side reading and other for back-side reading. Replace the lamps as follows:

WARNING

Never replace lamp without turning off the power.

WARNING

Wait at least 3 minutes after turning off the power before touching the lamp.

Replacing the front-side lamp

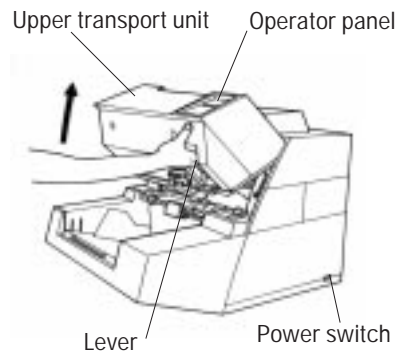

- ① Turn off the power switch.
- ② Open the upper transport unit. (See page 4-2)

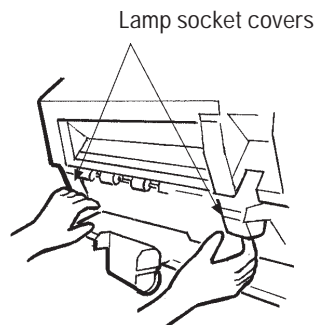

- ③ Remove the two lamp socket covers (U-shaped spring clips) by pulling them out of their positions.

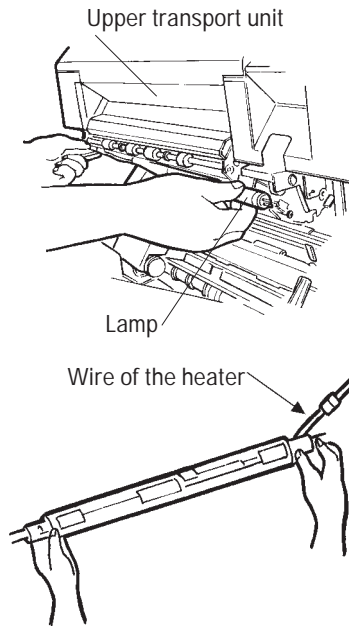

- ④ Rotate the lamp so that the two terminals on each end align with the exit slot on the lamp socket. Maintain the alignment and remove the lamp from the lamp sockets.

BASIC
OPERATION

CAUTION

Be careful not to pull the wire of the heater hard.

- ⑤ Separate the C-shaped heater assembly from the lamp body gently.

CAUTION

- **Be careful not to peel the tape on the heater assembly.**
- **If any visible damage on the heater assembly is observed, please contact manufacturer's authorized service center for proper repair service.**

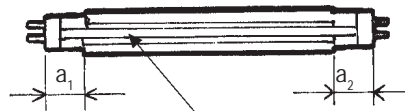

Window: transparent part

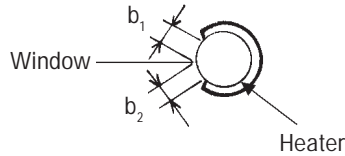

Cross-sectional view of lamp and heater

- ⑥ Re-attach a new lamp to the C-shaped heater.

Note:

Position the lamp so that the following lengths are the same:

$$a_1 = a_2$$

$$b_1 = b_2$$

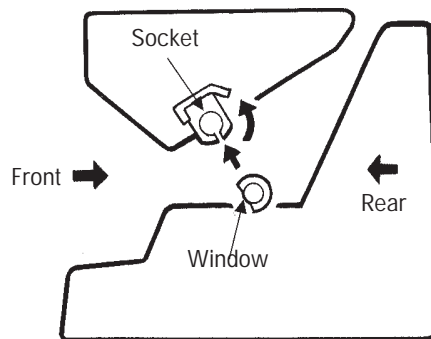

- ⑦ To re-install lamp/heater, reverse procedures in item ④ above.

Note:

When re-stalling the lamp, make sure to rotate the lamp in the direction as shown in the left figure.

- ⑧ Close the upper transport unit. (See page 4-2)

Replacing the back-side lamp

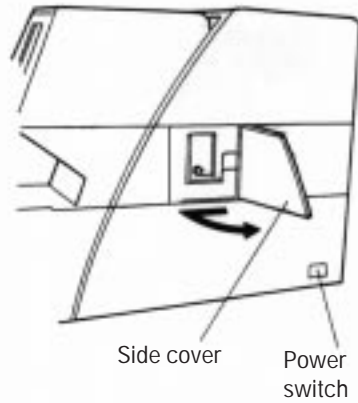

- ① Turn off the power switch.
- ② Slide and open the side cover (small cover on the center of the right cover).

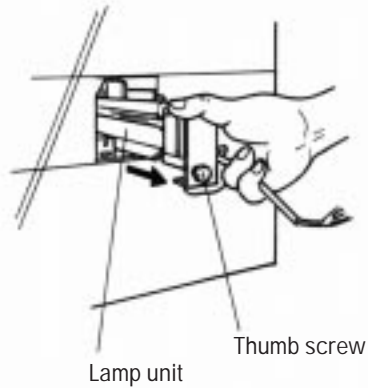

- ③ Turn the thumb screw to unlock the lamp unit and pull the unit out of the machine.

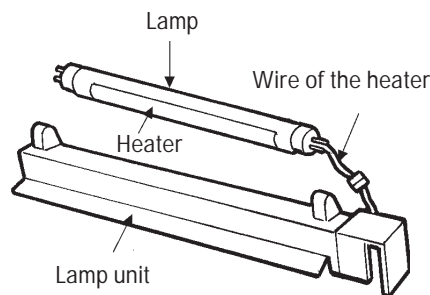

- ④ Rotate the lamp so that the two terminals on each end align with the exit slot on the lamp socket.

Maintain the alignment and remove the lamp from the lamp sockets.

CAUTION

Be careful not to pull the wire of the heater hard.

-
- ⑤ Separate the C-shaped heater from the lamp body gently.

CAUTION

- Be careful not to peel the tape on the heater.
- If any visible damage on the heater is observed, please contact manufacturer's authorized service center for proper repair service.

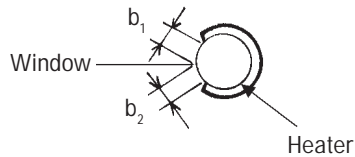
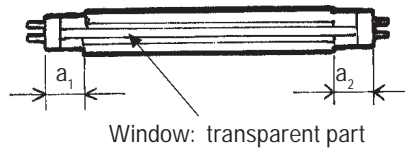

Cross-sectional view of lamp and heater

- ⑥ Re-attach a new lamp to the C-shaped heater.

Note:

Position the lamp so that the following lengths are the same:

$$a_1 = a_2$$

$$b_1 = b_2$$

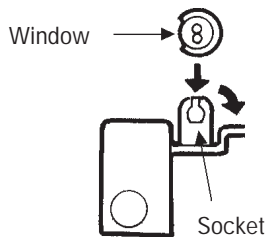

- ⑦ To re-install lamp/heater, reverse procedures in item 4 above.

Note:

Make sure to rotate lamp in the direction as shown in the left figure.

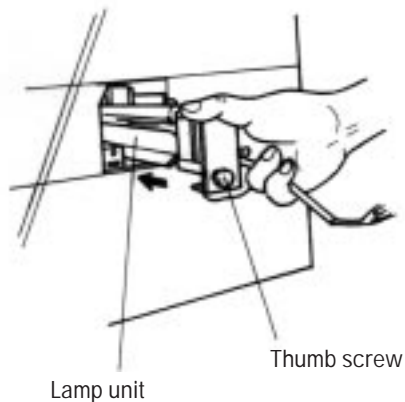

- ⑧ Align the lamp unit with the grooves on the machine and insert the lamp unit completely. Then, turn the thumb screw completely to avoid cover open error.
- ⑨ Attach the side cover.

Roller ASY Replacement

Replace the roller ASY as follows:

WARNING

Wait at least 3 minutes after turning off the power before replacement.

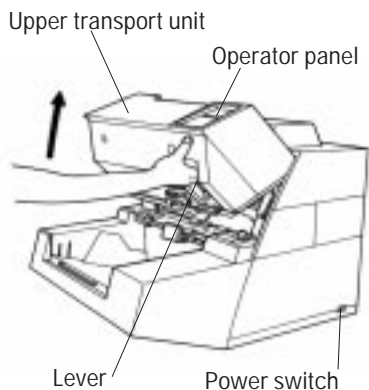

- ① Turn off the power switch.
- ② Open the upper transport unit. (See page 4-2)

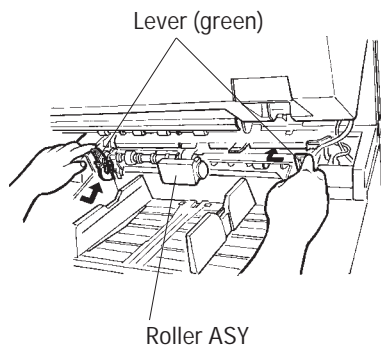
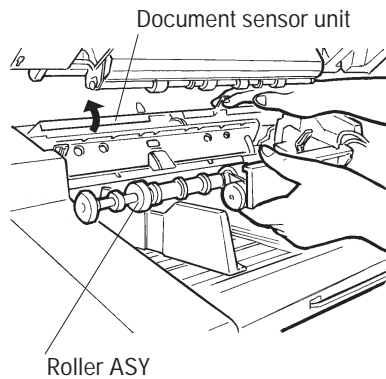
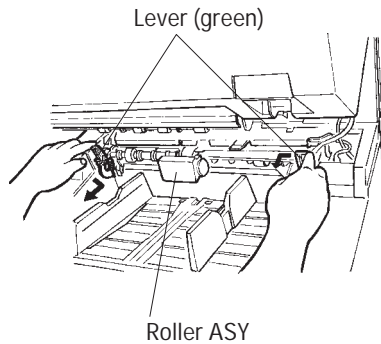

- ③ Disconnect the two relay connectors on the roller ASY. (front: 3 pin, back: 2pin)
- ④ Push the two levers (green) towards each other to disengage with the upper locking holes and lower down the two levers until they engage with the two levers locking holes.
- ⑤ Lift the document sensor unit and keep it at the upper position with one hand and pull the roller ASY out with the other hand.
- ⑥ Install a new roller ASY and return the document sensor unit to its original position.
- ⑦ Push the two levers (green) towards each other to disengage with the lower locking holes and lift them up until they engage with the two upper locking holes.
- ⑧ Connect the two relay connectors on the roller ASY. (front: 3 pin, back: 2 pin)
- ⑨ Close the upper transport unit. (See page 4-2)

Pick Roller Replacement

Replace the pick roller as follows:

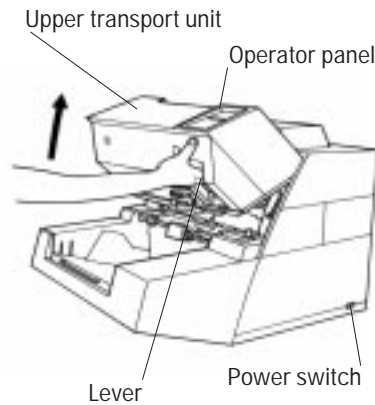

- ① Turn off the power switch.
- ② Open the upper transport unit. (See page 4-2)

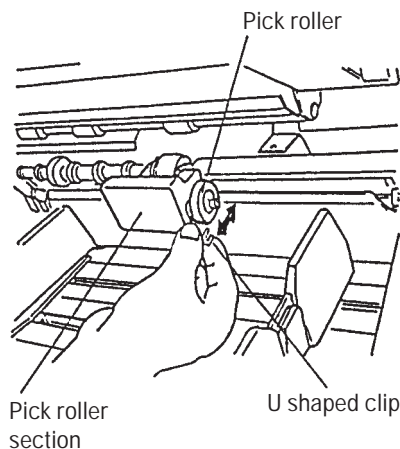

- ③ Put off U shaped clips on both ends of the pick roller shaft. Pull the pick rollers outward each other to remove.
- ④ Install a new pick rollers and put the U shaped clips on the pick roller shaft.
- ⑤ Close the upper transport unit. (See page 4-2)

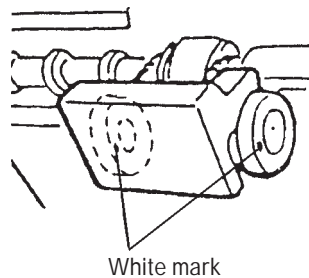

NOTICE

When you install pick rollers, make sure that the white marks on the side of the both pick rollers be in the right-hand side of the scanner.

Belt Replacement

Replace the belt as follows:

WARNING

Wait at least 3 minutes after turning off the power before replacement.

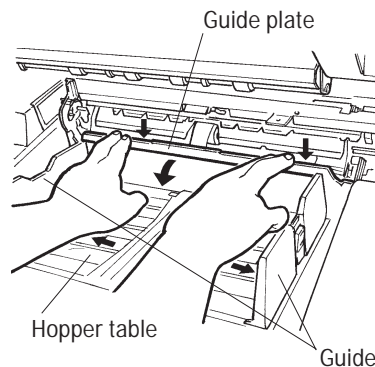
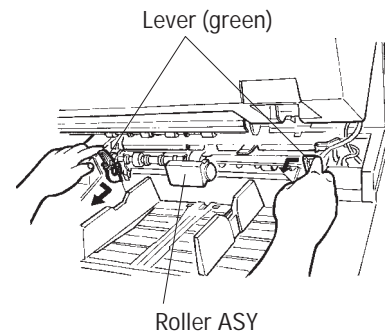
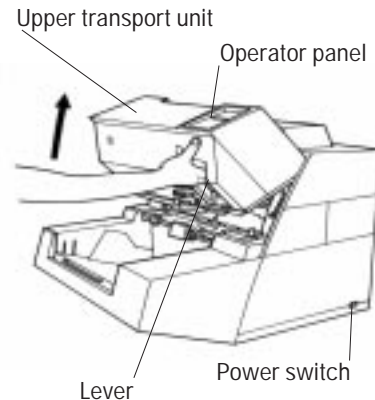

- ① Turn off the power switch. Make sure that the hopper table is at the bottom.
- ② Open the upper transport unit. (See page 4-2)
- ③ Disconnect the two relay connectors on the roller ASY.
- ④ Push the two levers (green) towards each other to disengage with the upper locking holes and lower down the two levers until they engage with the two levers locking holes.
- ⑤ Lift the document sensor unit and keep it at the upper position with one hand and pull the roller ASY out with the other hand.
- ⑥ Move the guide on the hopper table completely to the end.

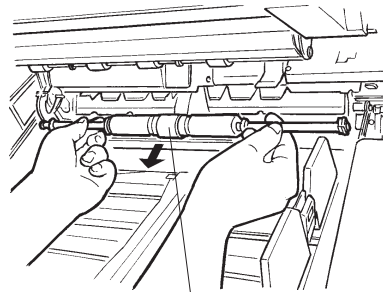

Belt ASY

⑦ Hold both ends of the guide plate and press them down to remove the guide.

⑧ Pull out the belt ASY.

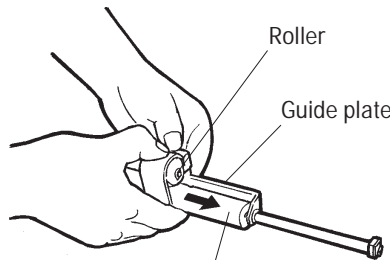

Belt ASY

⑨ Separate the belt roller and shaft from the guide plate.

⑩ Detach the belt from the roller.

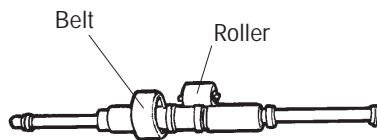
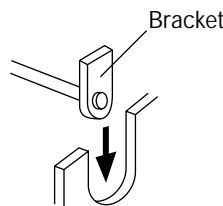

⑪ Mount a new belt by following step ⑦ to ⑩ in reverse. Align the bracket on the shaft as shown in the figure.

⑫ Lift the document sensor unit and keep it at the upper position with one hand and pull the roller ASY out with the other hand.

⑬ Close the document sensor unit downward.

Pad Replacement

Replace the pad as follows:

WARNING

Wait at least 3 minutes after turning off the power before replacement.

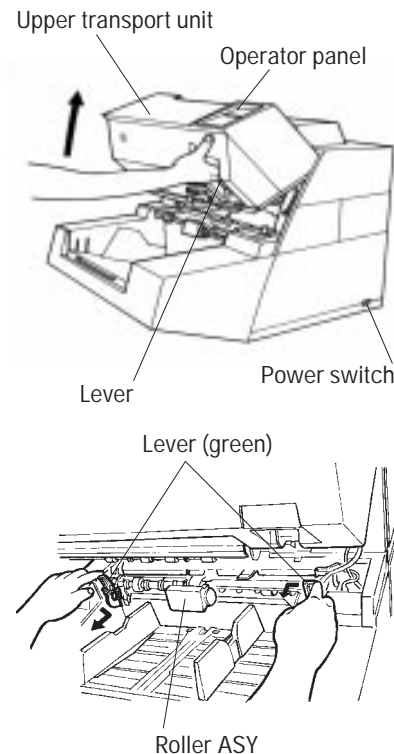

- ⑭ Push the two levers (green) towards each other to disengage with the lower locking holes and lift them up until they engage with the two upper locking holes.
- ⑮ Connect the two relay connectors on the roller ASY.
- ⑯ Close the upper transport unit. (See page 4-2)

- ① Turn off the power switch. Make sure that the hopper table is at the bottom.
- ② Open the upper transport unit. (See page B-2)
- ③ Disconnect the two relay connectors on the roller ASY.
- ④ Push the two levers (green) towards each other to disengage with the upper locking holes and lower down the two levers until they engage with the two levers locking holes.

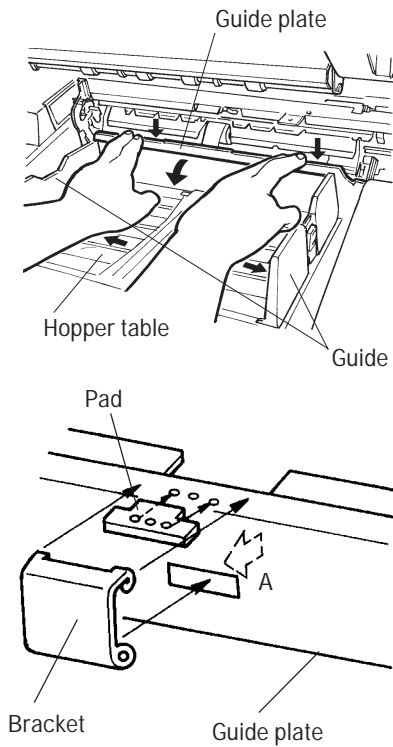

- ⑤ Lift the document sensor unit and keep it at the upper position with one hand and pull the roller ASY out with the other hand.
- ⑥ Move the guide on the hopper table completely to the end.
- ⑦ Hold both ends of the guide plate and press them down to remove the guide.
- ⑧ Press the bracket in the direction A, and detach the bracket and pad.

Note:

When assembling the pad, align the holes on the pad with the projection of the guide plate.

ERROR PROCESSING AND RECOVERY

This chapter provides how to handles temporary errors and equipment errors and what the operator should do to recover the scanner.

Device and Operator Actions for Temporary Errors

Table 5.1 lists the scanner and operator actions for temporary errors.

Table 5.1 Device and operator actions for temporary errors

LCD display (*1)	Scanner actions (*2)	Action to recover (*3)
PAPER JAM	<ul style="list-style-type: none"> - The normally read document is ejected to the stacker and the mechanism system is stopped to suspend the read operation. - “Temporary Error” is returned to the host computer and an error message is displayed on the LCD display. - The hopper table is lowered to the bottom. 	<ul style="list-style-type: none"> - Open the upper transport unit and remove the document on the transport path. Then, close the unit. - Return the jammed or double-fed document to the hopper and read it again.

*1: More detailed error messages are shown by the method specified in maintenance manual.

*2: Common action at temporary errors is 0.5 second interval buzzer for 3 seconds.

*3: The temporary errors are recovered by pressing the stop button.

Table 5.1 Device and operator actions for temporary errors (continued)

LCD display	Scanner actions	Action to recover
<p>HOPPER EMPTY</p>	<p>[When a read operation is activated, the pick sensor (SPK) goes off but not the hopper empty sensor (SHE) is off.]</p> <p>- If an error is detected, the hopper table is lowered. Then, “Temporary Error” is returned to the host computer and an error message is displayed on the LCD display.</p> <p>[The hopper empty sensor (SHE) goes on during reading.]</p> <p>- The read operation is terminated normally. After the document is ejected into the stacker, the hopper table is lowered.</p> <p>When a START, READ, or SENSE command is received from the host computer, “Temporary Error” is returned.</p> <p>*: This status is not detected in the manual mode.</p>	<p>- The error is recovered by issuing the start command.</p> <p>- Load documents on the hopper and start reading them.</p>

Table 5.1 Device and operator actions for temporary errors (continued)

LCD display	Scanner actions	Action to recover
COVER OPEN	<ul style="list-style-type: none"> - The mechanism system is stopped immediately and an error message is displayed on the LCD display. - If the scanner is not working, “Temporary Error” is returned when a SENSE, START, or READ command is received. - The hopper table is lowered to the bottom. 	<ul style="list-style-type: none"> - Close the upper transport unit or the endorser cover. - Or turn the thumb screw to lock the back-side lamp unit.
MISS PICK	<ul style="list-style-type: none"> - When an error is detected, the magnetic clutch (pick clutch) is turned off and the normally scan document is ejected to the stacker. Then, the mechanism system is stopped. - “Temporary Error” is returned to the host computer and an error message is displayed on the LCD display. - The hopper table is lowered to the bottom. 	<ul style="list-style-type: none"> - Open the upper transport unit and remove the document on the transport path. Then, close the unit. - Return the jammed document on the hopper and read it again.
ROLLER UNIT NOT SET	<ul style="list-style-type: none"> - The ADF roller ASY is not mounted correctly. 	<ul style="list-style-type: none"> - Open the upper transport unit and correct the roller unit setting, then close the upper transport unit. See chapter 4, “Roller ASY Replacement”.
HOPPER OVER- LOAD	<ul style="list-style-type: none"> - The documents loaded on the ADF exceed the specified number of pages. 	<ul style="list-style-type: none"> - Remove the document to the specified number of sheets.

Table 5.1 Device and operator actions for temporary errors (continued)

LCD display	Scanner actions	Action to recover
PRINT HEAD NOT SET	<ul style="list-style-type: none"> - Print head is not set. - “Temporary Error” is returned to the host computer and an error message is displayed on the LCD display. 	<ul style="list-style-type: none"> - Press “STOP” to reset the error and set the print head again.
PRINT HEAD ALARM	<ul style="list-style-type: none"> - Print head is not set correctly or does not work well. - “Temporary Error” is returned to the host computer and an error message is displayed on the LCD display. 	<ul style="list-style-type: none"> - Press “STOP” to reset the error and set the print head again. - If the error message is displayed on the LCD display again, change the print head.

Device and Operator Actions for Equipment Errors

Table 5.2 lists the scanner and operator actions for equipment errors.

Table 5.2 Device and operator actions for equipment errors

LCD display	Scanner actions	Action to recover
HOPPER ALARM	<ul style="list-style-type: none"> - The Check lamp lights and an error message is displayed on the LCD display. - The mechanism system is stopped. 	<ul style="list-style-type: none"> - Check if the lamp or heater is attached correctly. Replace lamp according to the replacement method. - If turning the power on again does not recover the scanner, contact the maintenance personal.
TRANSPORT ALARM	<ul style="list-style-type: none"> - The Check lamp lights and an error message is displayed on the LCD display. - The mechanism system is stopped. 	

Table 5.2 Device and operator actions for equipment errors (Continued)

LCD display		Scanner actions (*1)	Action to recover
LAMP ALARM 1		<ul style="list-style-type: none"> - The Check lamp lights and an error message is displayed on the LCD display. - The normally scan document is ejected to the stacker and the mechanism system is stopped. 	<ul style="list-style-type: none"> - Check if the lamp or heater is attached correctly. Replace lamp according to the replacement method. - If turning the power on again does not recover the scanner, contact the maintenance staff.
LAMP ALARM 2			
HEATER ALARM 1			
HEATER ALARM 2			
CCD UNIT ALARM 1			
CCD UNIT ALARM 2			
TEMP. ALARM			
FUSE ALARM * PRINT			
RAM ALARM * PRINT			
TIME-OUT ALARM PRINT *			
HARDWARE ALARM	EEPROM ALARM	<ul style="list-style-type: none"> - The Check lamp lights and an error message is displayed on the LCD display. - The FAIL signal on. 	<ul style="list-style-type: none"> - If turning the power on again does not recover the scanner, contact the maintenance personal.
	RAM 6 to 9 ALARM		
	V-RAM 1 to 4 ALARM		

* Endorser option only

*1: Common action at equipment error is the buzzer activated for 3 seconds.

DOCUMENT SPECIFICATION

This chapter provides document specification (size, type, limitations, grounding color area, drop-out color, and job separation sheet) for the scanner.

Document Size

Figure 6.1 shows document sizes which the scanner can read. For M3099EH, however, maximum size of A3 can be fed through the scanner.

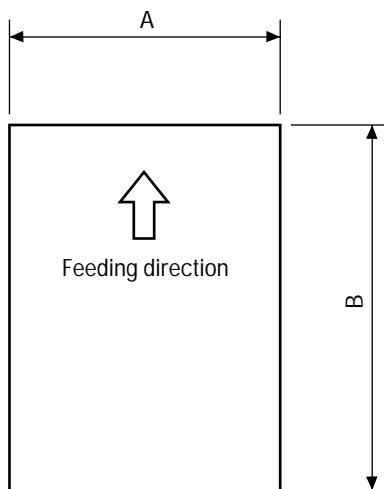

(Unit: mm)

Scanner	Maximum		Minimum	
	A	B	A	B
M3099EH	216	356	76	63
M3099EX	297	432	76	63

Figure 6.1 Document size

Document Quality

This section provides document types and weights available for the scanner, with precautions.

Document type

The recommended paper type for document is as follows:

NOTICE

Use specified paper only. (In rare occasion, double feeding may occur or document damage may occur.)

- Fine paper
- Plain paper (For example the paper specified for XEROX 4024)
- OCR paper

When using all other type paper, check that it is successfully fed by ADF before performing a reading operation.

Ream weight

The ream weight is as follows:

- 45 to 110 kg (13.9 to 34 lb, 52 to 127 g/m²)

Note:

Ream weight is a weight of 1000 sheets of paper whose size is 788 mm x 1091 mm.

Precautions

Be careful to scan the following documents. Preliminary document feed test may be necessary to avoid the unexpected errors. If the document slips in ADF (JAM error) or double feed occurs, separation pressure adjustment of Appendix C may be effective.

CAUTION

Never use an original document on this machine.

- Paper has clip
- Paper has ink, etc. is not dry.

-
- Paper thickness is not constant. (like envelope)
 - Paper has large rumples or curl. (See Note in next page)
 - Paper has folds or tears.
 - Tracing paper
 - Coating paper
 - Carbon paper
 - Carbonless paper
 - Paper size; smaller than 76 mm x 63 mm size, or larger than A3 width.
 - Other than paper; clothes, metal foil, or OHP film.
 - Photographic paper
 - Paper has notches on its side.
 - Shape is other than square.

NOTICE

Do not feed important original document so as not damage it in rare case.

When scanning a translucent document, set the density to light mode.

To prevent roller smudging, avoid scanning a document filled out in pencil. Clean the roller as often as possible when scanning many document. Once every 1000 pages is recommended.

The chemical composition of some carbonless papers reacts with the roller rubber and damages the rubber. Check the carbonless papers before use.

The carbonless papers may be used if:

1. Ream weight is 44 kg (12 lb) or more
2. Hopper load is 500 sheets or fewer

Note:

- If carbonless papers are used, clean the roller twice as often as usual.
- Paper should be straightend to fit the condition below.

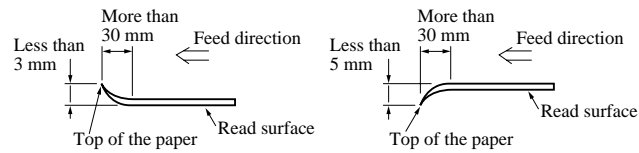

Document Limitations

This section provides restrictions on document used for the scanner.

Areas that must not be perforated

Perforations are prohibited in the shaded area of Figure 6.2 to avoid document size detection error or job separation sheet detection error or jam.

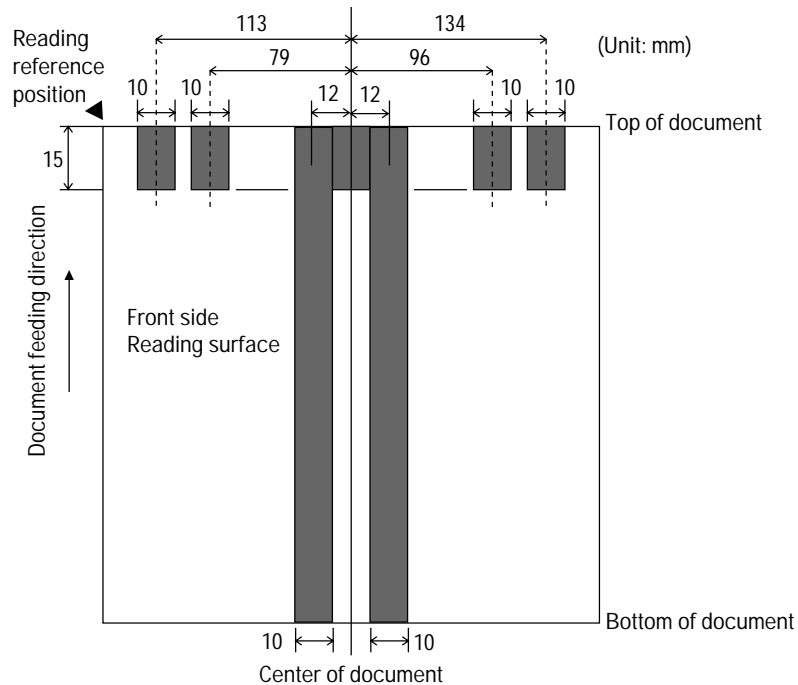

Figure 6.2 Areas that must not be perforated

Print prohibit areas on the front and back surfaces

Printing in area A on the front of a document may, in rare case, cause a document size detection error. Printing in area B on the front and back of a document may, in rare case, result a double feed error. Figure 6.3 shows print prohibit areas on the front and back surfaces.

Note: Figure 6.3 shows the document as viewed from the reading surface.

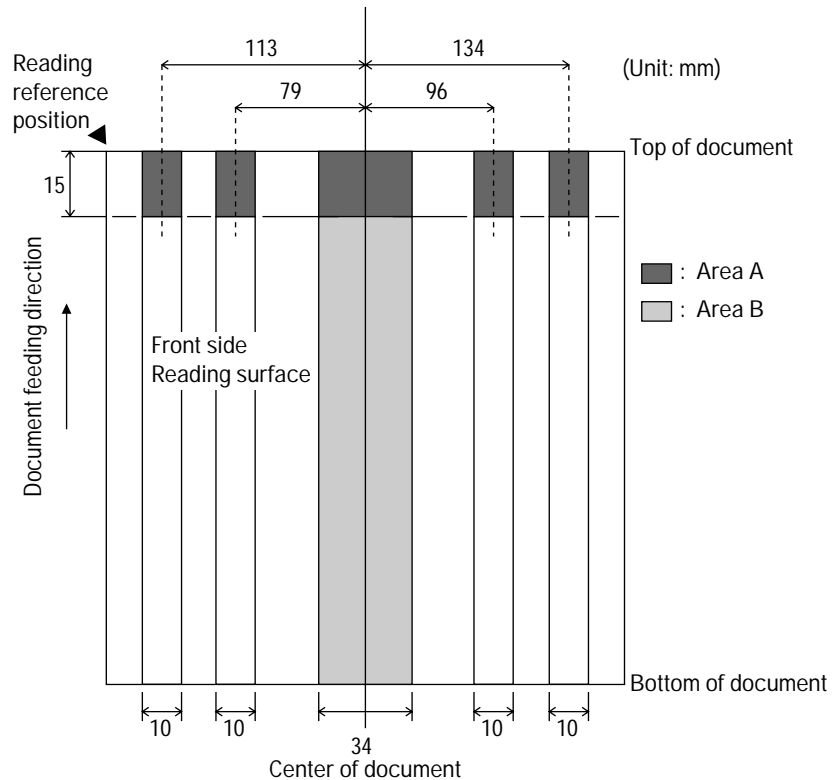

Figure 6.3 Print prohibit areas on the front and back surfaces

Grounding Color Area

As Figure 6.4 shows, the top 3-mm part of the read area on each surface should be left blank (grounding color) by specifying a drop-out color. If the drop-out color cannot be specified, select “Photo” for the document type (line drawing or photograph).

For details of the drop-out color, see next Section.

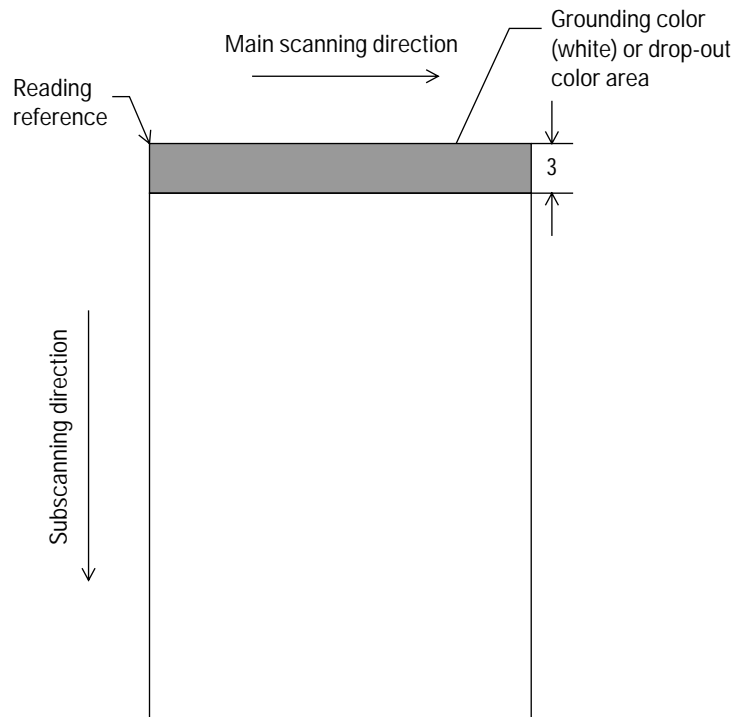

Figure 6.4 Grounding color area

Drop-out Color

A drop-out color is color visible by a human eye but not visible to the scanner.

To check the grounding color of document for a drop-out color, use the method and follow the standards given below.

Print density measurement

The spectrum chart shows in Figure 6.5 is used to measure print density.

The measurement must be made in one of the following ways:

- A light source using fluorescent G54
- Macbeth PCS meter PCM II is used, which requires a filter.

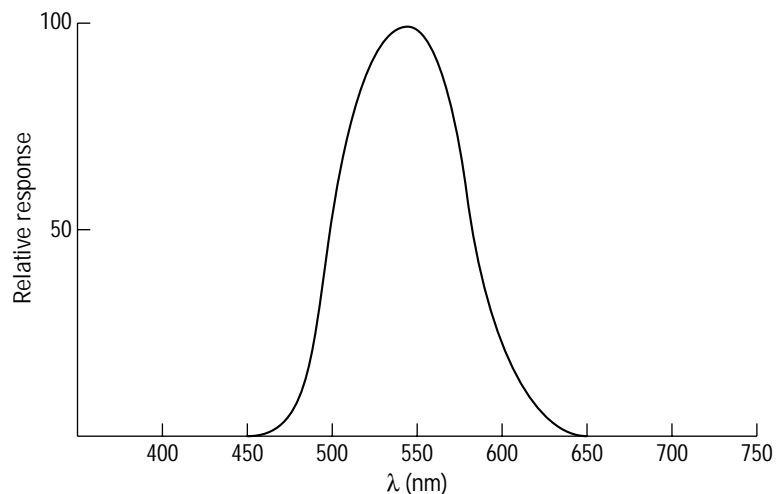

Figure 6.5 Spectrum band

Drop-out color standards

In the spectrum of fluorescent lamp G54, the PCS value must satisfy the following standards:

- Maximum: 0.14 or less
- Average: 0.1 or less

Job Separation Sheet

Shape

The following Figure 6.6 shows the basic of the document.

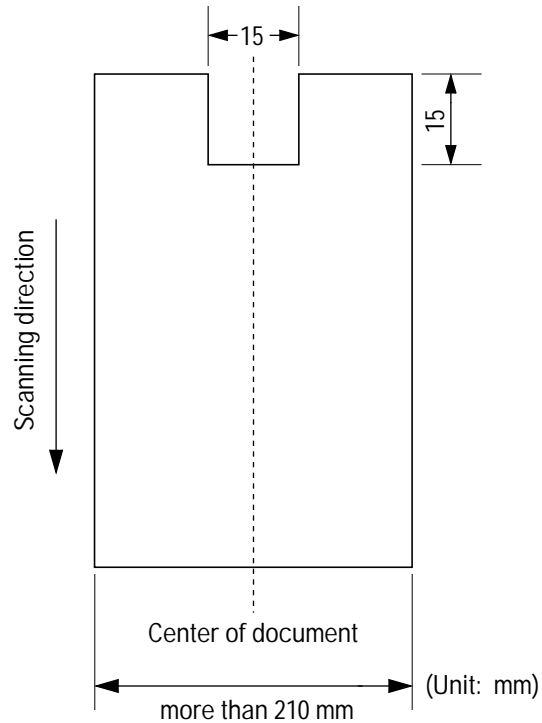

Figure 6.6 Shape of document

Document type

The document type and ream weight specifications given in page 6-2.

However, the document size shall be A4 or larger (210 mm or more wider).

CONSUMABLES AND ACCESSORIES

This chapter provides consumables and accessories of the scanner.

Consumables

Table 7.1 lists consumables used for the scanner. Be sure to keep some spare parts in stock.

The abrasion counter can be used to check the number of scanned documents. (See page 4-24)

Table 7.1 Consumables

Name	Specification	Remark
Lamp	CA02950-0548	Up to 500 hours or more. Two lamps per scanner
Pick roller	CA01023-F242	Up to 300,000 sheets or one year. Requires two per scanner.
Roller ASY	CA02869-F230	Up to 600,000 sheets or one year. This part contains Pick Roller but the life of the Roller Units does not include the life of the Pick Roller.
Belt	CA02869-Y218	Up to 300,000 sheets or one year.
Belt ASY	CA02869-F220	Up to 600,000 sheets or one year. This part includes Separation Belt but the life of the Belt Assembly does not include the life of the Separation Belt.
Pad	CA01023-G290	Up to 300,000 sheets or more.
Print head	CA01023-0701	Black ink for endorser option. Ten print heads are packed. Each print head has the life of 20,000 sheets at 10 characters per sheet.

Accessories

Table 7.2 lists accessories of the scanner.

Table 7.2 Accessories

Name	Quantity	Remark
Power cable (100 V or 200 V)	1	
Operator's guide	1	

CLEANING

This chapter provides cleaning locations and frequencies, cleaning tools, and procedure.

Cleaning Locations and Frequencies

Table 8.1 lists cleaning locations and frequencies of the scanner.

Table 8.1 Cleaning locations and frequencies

Locations		Tools	Frequencies
Front-side lamp		Dry cloth	Every 50,000 sheets
Roller and belt		Cleaning sheet	Every 50,000 sheets
		Cleaner F2	
		Dry cloth and isopropyl alcohol	Every 200,000 sheets
Transport path		Dry cloth and isopropyl alcohol	
Glass surface			
Sensor tops	Document width-detection		
	Document detection		
	Front-side reading timing detection		
	Ejection detection		

Note: Depending on use, it may be necessary to clean more frequently.

Cleaning Tools

The tools required for cleaning are as follows:

- Cleaning cloth (dry cloth, lint free)
- Cleaner F2
- Isopropyl alcohol (Cleaner F1)

- Cleaning sheet
- Q-Tips

NOTICE: Cleaner F2 should be used for steel rollers.

Procedure

This section provides instructions on how to clean each section of the scanner.

WARNING

Wait at least 3 minutes after turning off the power before cleaning.

Cleaning the front-side lamp

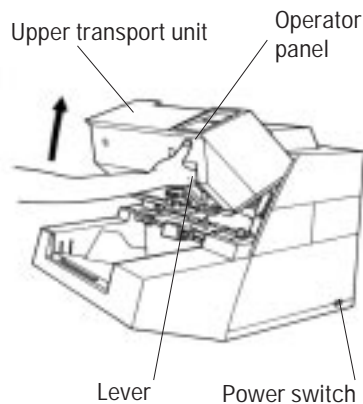

- ① Turn off the power switch.
- ② Open the upper transport unit. (See page 4-2)

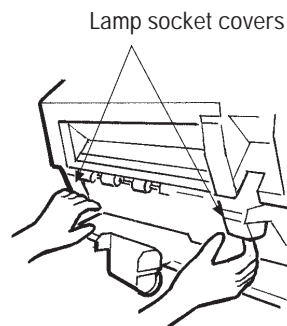

- ③ Remove the two lamp socket covers (U-shaped spring clips) by pulling them out of their positions.

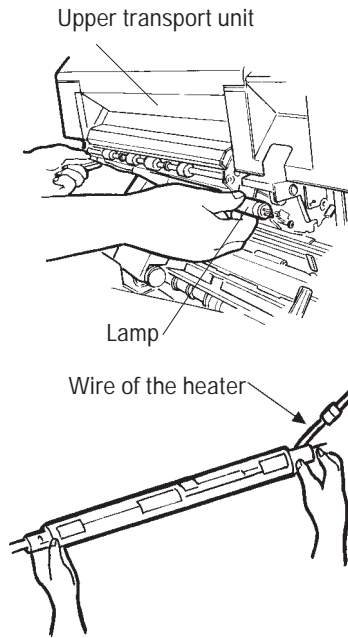

- ④ Rotate the lamp so that the two terminals on each end align with the exit slot on the lamp socket. Maintain the alignment and remove the lamp from the lamp sockets.

CAUTION

Be careful not to pull the wire of the heater hard.

- ⑤ Clean the lamp with a dry cloth.

CLEANING

CAUTION

- Be careful not to peel the tape on the heater.
- If any visible damage on the heater is observed, please contact manufacturer's authorized service center for proper repair service.

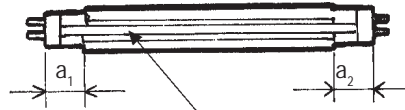

Window: transparent part

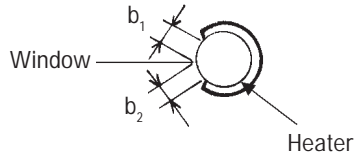

Cross-sectional view of lamp and heater

Note:

Make sure that the following lengths are the same:

$$a_1 = a_2$$

$$b_1 = b_2$$

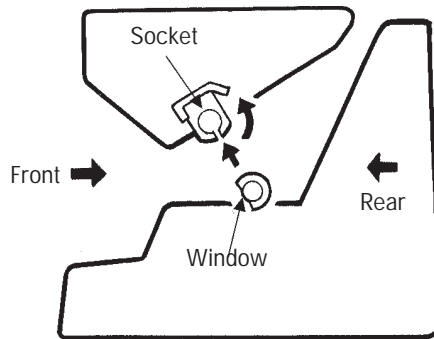

- ⑥ To re-install lamp/heater, reverse procedures in item ④ above.

Note:

When re-installing the lamp, make sure to rotate the lamp in the direction as shown in the left figure.

- ⑦ Close the upper transport unit. (See page 4-2)

Cleaning the rollers

Cleaning the rollers with Cleaning Sheet:

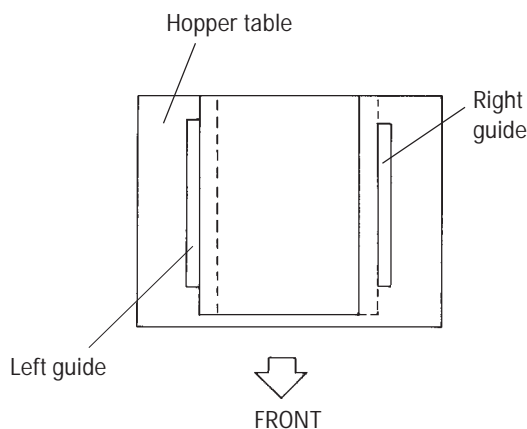
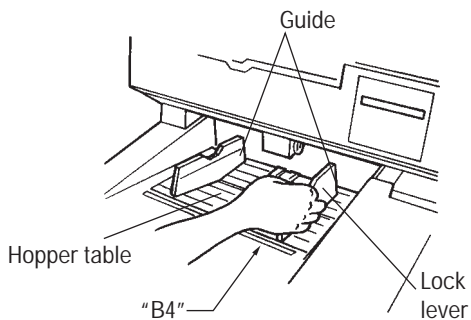

- ① Set the hopper table guides to the B4 width.
- ② Remove protective paper from the cleaning sheet. With the adhesive side up, place the cleaning sheet on the hopper table by aligning it with the left guide.
- ③ Press [MODE2] twice, [MODE1] once, then [START]. (The hopper table goes up and the cleaning sheet is transported.)
- ④ By aligning with the right guide, place the same cleaning sheet on the hopper table with the adhesive side up.
- ⑤ Transport the cleaning sheet by the switch operations of 3.
- ⑥ Place a new cleaning sheet on the hopper table with the adhesive side down, and repeat steps 2 to 5.

CLEANING

Cleaning the rollers with dry cloth and alcohol (Cleaner F1)

This roller exists only 1000 sheets hopper type.

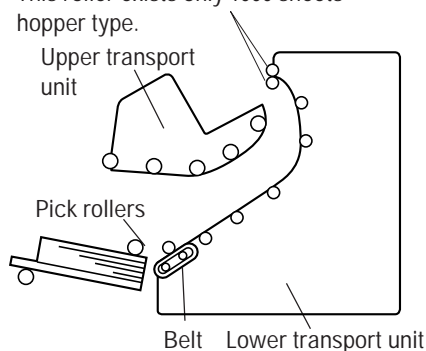

- ① Open the upper transport unit. (See page 4-2)
- ② Wipe the pick rollers, belt and the upper and lower transport unit rollers with a dry cloth or cloth soaked in isopropyl alcohol.
- ③ Close the upper transport unit. (See page 4-2)

Cleaning the steel rollers with cleaner F2

This cleaning is required when the toner stick to the roller.

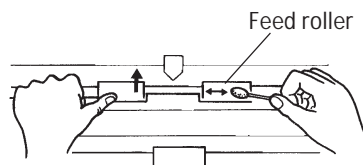

- ① Open the upper transport unit. (See page 4-2)
- ② Apply a small amount of cleaner F2 to a Q-Tips. While turning the roller slowly, wipe its surface with Q-Tips.

Cleaning the transport paths

Clean the transport paths as follows

This roller exists only 1000 sheets hopper type.

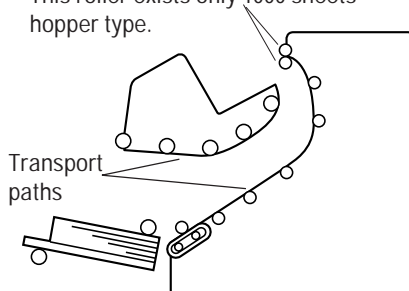

- ① Open the upper transport unit. (See page 4-2)
- ② Wipe the transport paths with a dry cloth or cloth soaked in isopropyl alcohol. Use a vacuum cleaner when removing paper dust from the paths.
- ③ Close the upper transport unit. (See page 4-2)

Cleaning the glass surface

Clean the glass surface of the sheet guide assembly as follows:

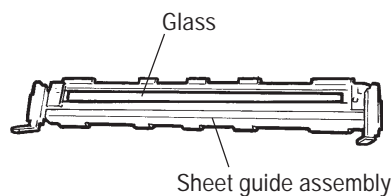

- ① Open the upper transport unit. (See page 4-2)
- ② Lift the sheet guide assembly by holding the handles on both ends and pull it out of the machine.
- ③ Wipe the glass surface (on both sides) with a dry cloth or cloth soaked in isopropyl alcohol.
- ④ Re-install the sheet guide assembly.
- ⑤ Close the upper transport unit. (See page 4-2)

CLEANING

Cleaning the sensors

Document width detection sensor

Clean the four document width detection sensors as follows:

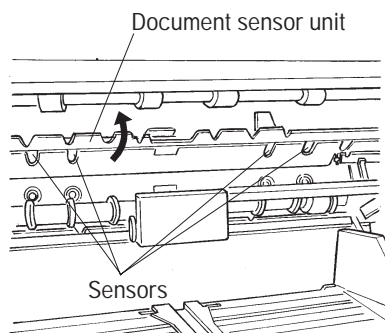

- ① Open the upper transport unit. (See page 4-2)
- ② Hold the handles of the document sensor unit and keep the unit open.
- ③ Wipe the top of the four sensors with a dry cloth or cloth soaked in isopropyl alcohol.

-
- ④ Close the document sensor unit.
 - ⑤ Close the upper transport unit. (See page 4-2)

Document detection sensor

Clean the document detection sensor as follows:

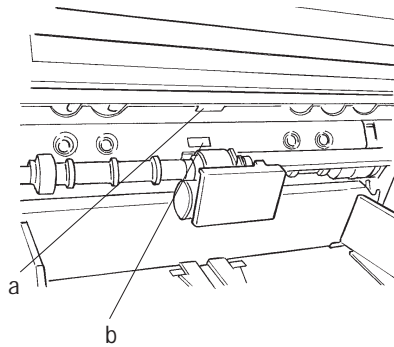

- ① Open the upper transport unit. (See page 4-2)
- ② Hold the handles of the document sensor unit and keep the unit open.
- ③ Wipe the two sensor windows (a and b) with a dry cloth or cloth soaked in isopropyl alcohol.
- ④ Close the document sensor unit.
- ⑤ Close the upper transport unit. (See page 4-2)

Reading timing sensor

Clean the reading timing sensor as follows:

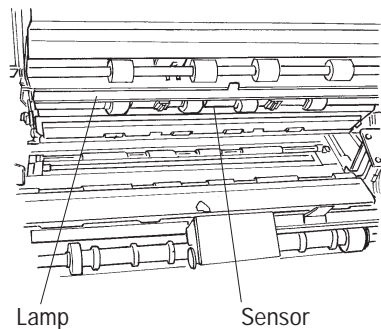

- ① Open the upper transport unit. (See page 4-2)
- ② Wipe the sensor top of sensor at the transport path of the upper transport unit with a dry cloth or cloth soaked in isopropyl alcohol.
- ③ Close the upper transport unit. (See page 4-2)

Ejection sensor

Clean the ejection sensor as follows:

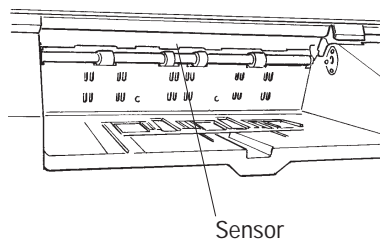

- ① Open the upper transport unit. (See page 4-2)
- ② Wipe the top of sensor at the rear center of the device with a dry cloth or cloth soaked in isopropyl alcohol.
- ③ Close the upper transport unit. (See page 4-2)

CLEANING



ENDORSER

A1. Specifications Table A.1 lists the endorser specifications.

Table A.1 Endorser specifications

Item	Specification
Printing method	Ink jet printing method
Characters	Alphabet: A to Z, a to z Number : 0, 1, to , 9 Symbol : ! " # \$ % & ' () * + , - . / : ; < = > ? @ [¥] ^ _ ` { } (blank)
Maximum number of characters	20
Character size	2.9× 1.5 mm (0.11" × 0.06") (hight × width)
Character pitch	Approx. 2.54 mm (0.1")
Print area	Back-side of the document A ≥ 5 mm (0.2") B ≥ 28 mm (1.1") C ≥ 20 mm (0.79") D ≥ 5 mm (0.2")

ENDORSER

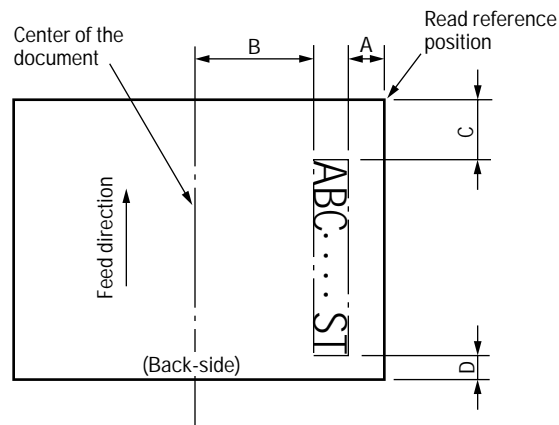

Figure A.1 Print area

A2. Panel operation

By the operator panel you can set following conditions. Other conditions such as print offset, print characters can be set by the host machine.

A2.1 How to set the endorser ON (or OFF)

When you use the endorser, you must set the endorser ON as follows.

<< SETUP MODE >>

Screen 1

<< SETUP MODE >>

ENDORSER INITIAL

Screen 2

ENDORSER	VALUE
* ON	0 0 0 1

Screen 3

- ① While pressing the [Mode 1], turn on the power of the scanner. Then the LCD displays the SETUP MODE initial screen. (Screen 1)
- ② Press [Mode 1] eight times to go to the ENDORSER INITIAL screen. (Screen 2) Then press [Mode 2]. If “ON” is displayed, the endorser is already on. (Screen 3)
- ③ If “OFF” is displayed, press [Mode 1], until “OFF” blinks. Then press [Mode 2] to turn the endorser ON. (Screen 3)

If you want to set the status in EEPROM, go to ⑤. Then if you want to close the job, go to ⑥ and ⑦.

NOTICE: Set the endorser ON only when you use endorser, or the characters may be printed on every scanned document.

A2.2 How to set the initial number

Initial number is the number which the scanner starts printing or returns after the reset of print number.

ENDORSER	VALUE
* ON	0 0 0 5

Screen 4

EEPROM WRITE?

(Mode 2 Write)

Screen 5

- ④ At Screen 3, press the [Mode 1] until the digit you want to changes blinks. Then press [Mode 2] until the digit changes as you want. (Screen 4: In this case the initial number is five.)
- ⑤ To set the status in EEPROM, press [Mode 1] until * blinks. Then press [Mode 2] to change the LCD display into Screen 5. If you want to set, press [Mode 2]. And the LCD displays Screen 6 about three seconds.



Screen 6

⑥ If you want to return to the ENDORSER INITIAL screen (Screen 2), press [Mode 1] and [Mode 2] at a time.

⑦ If you want to return to the initial status to read, press [STOP].

A2.3 How to set the print number reset condition

You can choose whether to reset or not when HOPPER EMPTY is detected.



Screen 7

⑧ At Screen 1 press [Mode 1] nine times to go to the ENDORSER RESET METHOD screen. (Screen 7)

⑨ Press [Mode 2] to see Screen 8. If “ON” is displayed, the print number will be reset when HOPPER EMPTY is detected. If “OFF” is displayed, it wouldn't. The “ON” or “OFF” status flips each time you press [Mode 1]. The status will be set in EEPROM automatically.

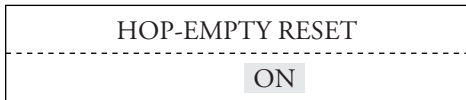

Screen 8

⑩ If you want to return to Screen 7, press [Mode 2].

If you want to close the job, go to ⑦.

A2.4 How to reset the print number manually

You can reset the print number to the initial number by operator panel as follows.



Screen 9

① At Screen 1 press [Mode 1] ten times to go to the ENDORSER RESET screen. (Screen 9)

② Press [Mode 2] to see Screen 10. You may see current print number. If you want to reset the number, press [Mode 2]. And you can see Screen 11 for 3 sec. If you don't want it, press [Mode 1] to go to Screen 9.

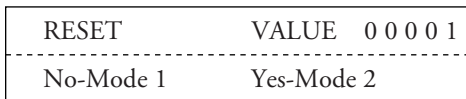

Screen 10

If you want to close the job, go to ⑦.

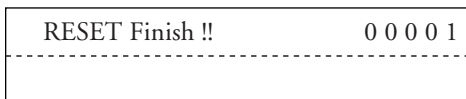

Screen 11

A2.5 How to reset the print head life counter

You must reset the print head life counter, when you replace the print head.



Screen 12

⑬ At Screen 1 press [Mode 1] eleven times to go to INK RESET screen. (Screen 12)

⑭ Press [Mode 2] to see Screen 13.

If you want to reset the counter, press [Mode 2]. And you can see Screen 14 for 3 sec.

If you don't want it, press [Mode 1] to go to Screen 12.



Screen 13

If you want to close the job, go to ⑦.

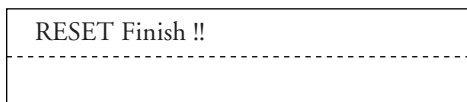

Screen 14

A2.6 How to test the printing by the operator panel operation

You can check the print result by the following procedures.

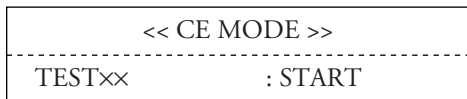

Screen 15

⑮ Set the endorser ON by the procedure of the section A2.1.

⑯ While pressing the [Mode 2], turn the power of the scanner on. Then the LCD displays the MAINTENANCE MODE initial screen. (Screen 15)

⑰ Press [Mode 2] once and press [Mode 1] once. Place the document on the stacker. Then press [START].

NOTICE: The scanner prints the five digit numbers from the initial number by the increment of one.

NOTICE: Before pressing [START], you can set document size, resolution and so on. (See OPERATOR'S GUIDE)

A3. Print head handling

A3.1 Replacing the print head

When “INK EMPTY” is displayed in LCD display, the operator is responsible to change the print head as follows.

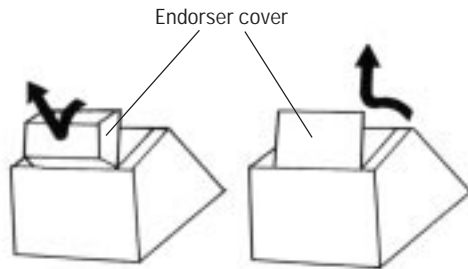

or

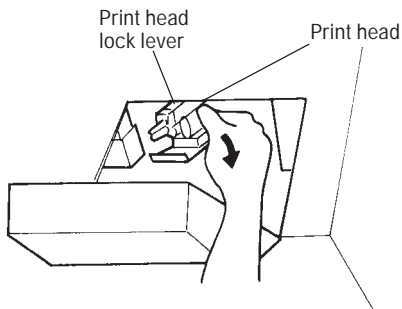

- ① Open and remove the endorser cover at the rear top corner of the scanner. Power of the scanner will turn off, if the power is on at cover open.
- ② Turn the print head lock lever up, then replace the print head.
- ③ Attach the new print head in the endorser and turn the print head lock lever back.
- ④ Close the endorser cover back.
- ⑤ Reset the print head life counter by the procedure stated in section A2.5. (See NOTICE)

You can test the printing by the procedure in section A2.6

NOTICE: The reset of the print head life counter is important to correctly detect the life of the new print head.

ENDORSER

A3.2 Print head position adjustment

You can adjust the print position in mainscanning direction manually. The position you can set is limited as stated in section 1.

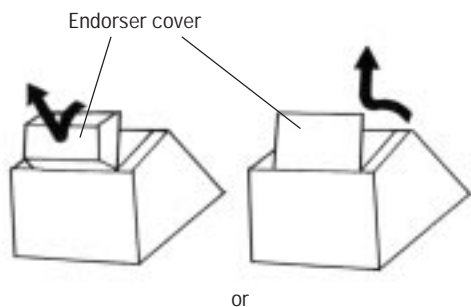

or

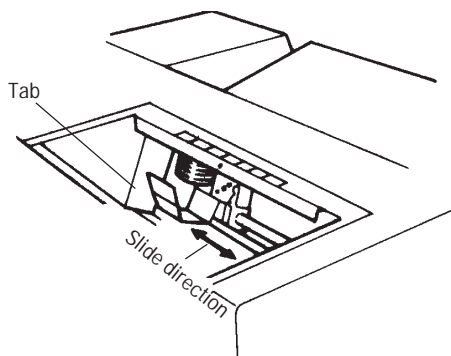

- ① Open and remove the endorser cover at the rear top corner of the scanner. Power of the scanner will turn off, if the power is on at the cover open.
- ② Pinch the tab near the print head and slide it to the position you want to print. The print position is indicated by the indicator behind the tab and the label attached on the rear cover.
- ③ Close the endorser cover.

You can test the printing by the procedure in section A2.6.

SETUP MODE

This chapter explains the setup mode of the scanner.

B1. Activating the setup mode

When you activate the setup mode, you must set as follows.

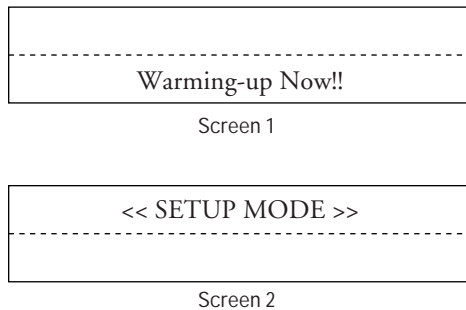

- ① While pressing the [Mode 1], turn on the power of the scanner. Then the LCD displays Screen 1.
- ② After a while the LCD displays the SETUP MODE initial screen. (Screen 2) (Or after turning on the power, press [Mode 1] at readable status then the LCD displays Screen 2.)
- ③ Press the [Mode 1] to go to the SETUP MODE menu screen. Press the [Stop] to go to the readable status.

B2. Operational transition in the setup mode

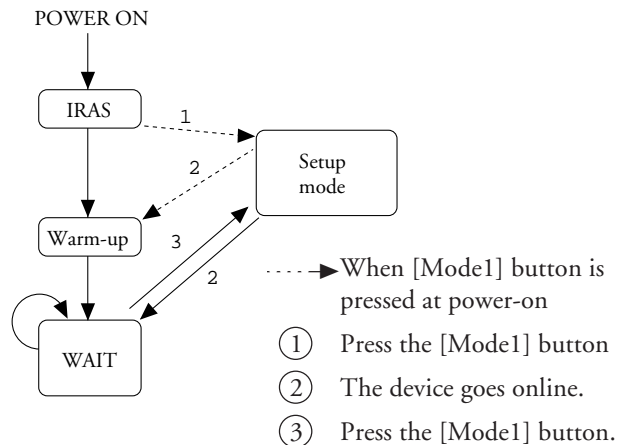

B3. Contents of the setup mode

The setup mode can be classified into seventeen:

Mode	Setup type	Contents
1	Setting double feed detection	Set in EEPROM whether double feed detection is done or not.
2	Setting IPC-2 pre-set	Set in EEPROM the pattern No. of IPC-2 pre-set mode.
3	Reset of abrasion counter	Reset the abrasion counter after Belt/Roller are exchanged.
4	Setting buzzer	Set in EEPROM whether the buzzer function is on or off.
5	Setting pre-pick	Set in EEPROM whether pre-picking is done for fast reading or not.
6	Adjusting LCD contrast	Set in EEPROM the LCD contrast.
7	Setting pick speed	Set in EEPROM whether pick speed is fast or slow.
8	Setting initial value of endorser number	Set the using of endorser and the initial number. The set value is able to be stored in EEPROM.
9	Setting method of endorser reset	Set in EEPROM whether the number is reset by hopper empty detection.
10	Reset of endorser number	Reset the number to initial value.
11	Reset of ink counter	Reset the ink counter after the print head has been replaced.
12	Setting RS232C transfer rate	Set in EEPROM the transfer rate. (1200/2400/4800/9600)
13	Setting picking start time	Set in EEPROM the time from when the hopper empty sensor is blocked in manual mode until picking begins.
14	Setting picking time	Set the time from when picking begins until the SF1 sensor is blocked by paper.
15	Setting time-out limit	Set the time from when a command is issued in manual mode until paper is actually detected.
16	Setting hopper time	Set the time from when Start Command Timeout limits until hopper table is lowered.
17	Setting heater control	Set in EEPROM whether the heater control is on or off.

B3.1 Setting double-feed detection

When you set the using of double-feed detection, you must set as follows.



Screen 3

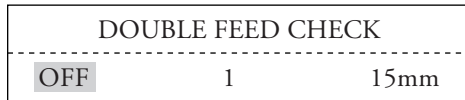

Screen 4



Screen 5

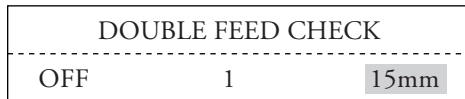

Screen 6

- ④ At Screen 2, press [Mode 1] once to go to the DOUBLE FEED CHECK screen. (Screen 3)
- ⑤ Press [Mode 2] to see Screen 4. If “ON” is displayed, the error will be detected when the double-feed is occurred. If “OFF” is displayed, it wouldn't. The “ON” or “OFF” status flips each time you press [Mode 2].
- ⑥ Press [Mode 1] to see Screen 5. This means how to defect the double-feed as follows. “1” is the method by comparing with the length of the first paper. “2” is the method by the output of Document detection sensor in addition to “1”.
At Screen 5, press the [Mode 2] until the number changes as you want.
- ⑦ Press [Mode 1] to see Screen 6. This means the length to compare with the paper based on. If you choose “1” or “2” and set “15mm”, the double-feed is detected when the scanned paper length is 15mm longer than the first paper.
At Screen 6, press the [Mode 2] until the number changes as you want. (You can choose 10, 15 or 20mm. The default is 15mm.)
- ⑧ Press [Mode 1] and [Mode 2] at a time to see Screen 3. The settings are stored to EEPROM.
- ⑨ When you close the setup mode, press [Stop]. Then the readable screen is displayed.

SETUP MODE

Mode	Details
ON/OFF	“OFF” is default setting.
1	“1” is default setting. This mode is used when the batch of paper which length are same are scanned. When the paper which tears and wrinkled are scanned, Scanner may mistake it also.
2	This mode is used when the batch of paper which length and thickness are same are scanned. However, when the thin papers are scanned, Scanner may mistake to detect the Double-feed rarely. In case of this, please test to scan the thin papers in advance.

B3.2 Setting IPC-2 pre-set mode

When you set the using of IPC-2 pre-set mode, you must set as follows.

<< SETUP MODE >>

 IPC-2 SET

Screen 7

⑩ At Screen 2, press [Mode 1] twice to go to the IPC-2 SET screen. (Screen 7)

IPC-2 SET

 No

Screen 8

⑪ Press [Mode 2] to see Screen 8 or 9. If “No” is displayed, IPC-2 pre-set mode is not used. If pattern number (“1”-“5”) is displayed, IPC-2 pre-set mode is used. “No” or number status flips each time you press [Mode 1]. (The default setting is “No”).

IPC-2 SET

 X

Screen 9

⑫ If you press the [Mode 2] at Screen 8, you return to Screen 7. The setting is stored to EEPROM. If you press the [Mode 2] at Screen 9, you go to Screen 10.

Panel/Host Set Ignore

 No-Model Yes-Mode 2

Screen 10

⑬ If you press the [Mode 1] at Screen 10, IPC-2 pre-set mode can be not used. Also the setting is changed to “No” obligatory and stored to EEPROM. If you press the [Mode 2] at Screen 10, IPC-2 pre-set mode can be used and the setting number is stored to EEPROM.

Host Set Ignore

 No-Model Yes-Mode 2

Screen 11

When you close the setup mode, go to ⑨.

<Classification of user's paper>

User's paper are classified in line-art scanning as follows:
 The horizontal axis shows the background density/color of paper.
 The vertical axis shows the density of character/line.

		Background density		Background color		
		Normal ←	→ Dark	Red	Green	Blue
Character density	Normal ↑	①	③			
	↓ Light	②		④	⑤	

①–⑤ are the pattern number set in setup mode.

①: Normal background and character.

②: Normal background and light character.

③: Dark background and normal-density character.

④: Light character on red paper.

⑤: Light character on green paper.

<Notice>

- (1) For patterns “1” to “5” when the power is turned on
 Check that IPC-2 for front/back sides are installed during initialization.
 If IPC-2 for either the front or back side is not installed, the scanner regards as no setting obligatory and changes the memory of EEPROM.
- (2) When IPC-2 pre-set is executed in setup mode
 Check that IPC-2 for front/back sides are installed when the scanner enters in IPC-2 pre-set.
 If IPC-2 for either the front or back side is not installed, the scanner does not enter in IPC-2 pre-set.
- (3) When IPC-2 pre-set mode is executed
 When IPC-2 pre-set mode is executed in online mode, the reading parameter is valid or invalid (Host setting is invalid) as follows:

SETUP MODE

	Reading parameter							
	Reading mode	Transfer mode	Transfer rate	Resolution	Start of reading	Density	Line-art /Photo	Halftone
Valid	<input type="radio"/>	<input type="radio"/>	<input type="radio"/>	<input type="radio"/>	<input type="radio"/>			
Invalid						<input type="radio"/>	<input type="radio"/>	<input type="radio"/>

	Reading parameter							
	DTC	Size	Portrait /Landscape	Picking	Document selection	γ patterns	Contrast	Automatic separation
Valid		<input type="radio"/>	<input type="radio"/>	<input type="radio"/>	<input type="radio"/>			
Invalid	<input type="radio"/>					<input type="radio"/>	<input type="radio"/>	<input type="radio"/>

	Reading parameter					
	Conversion	Sharpness	Outline extraction	Overlay	Simplified DTC	Zooming
Valid	<input type="radio"/>					<input type="radio"/>
Invalid		<input type="radio"/>	<input type="radio"/>	<input type="radio"/>	<input type="radio"/>	

B3.3 Reset of abrasion counter

When you reset the abrasion counter, you must set as follows.

<< SETUP MODE >> ----- PAPER COUNT RESET
--

Screen 12

RESET COUNT 123456 ----- No-Model Yes-Mode 2

Screen 13

RESET Finish!! 000000 -----

Screen 14

⑭ At Screen 2, press [Mode 1] three times to go to the PAPER COUNT RESET screen. (Screen 12)

⑮ Press [Mode 2] to see Screen 13. You may see current paper count. If you want to reset the count, press [Mode 2]. And you can see Screen 14 for 3 seconds. If you don't want it, press [Mode 1] to go to Screen 12.

⑯ When you close the setup mode, go to ⑰.

B3.4 Setting buzzer

When you set the using of buzzer, you must set as follows.

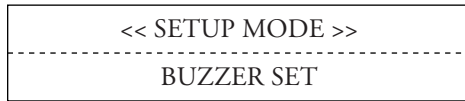

Screen 15



Screen 16

- ⑰ At Screen 2, press [Mode 1] four times to go to the BUZZER SET screen. (Screen 15)
- ⑱ Press [Mode 2] to see Screen 16. If “ON” is displayed, the buzzer will ring when the error is occurred. If “OFF” is displayed, it wouldn’t. The “ON” or “OFF” status flips each time you press [Mode 1]. The status will be set in EEPROM automatically.
- ⑲ If you want to return to Screen 15, press [Mode 2]. When you close the setup mode, go to ⑨.

B3.5 Setting pre-pick

When you set the using pre-pick, you must set as follows.



Screen 17



Screen 18

- ⑳ At Screen 2, press [Mode 1] five times to go to the PREPICK SET screen. (Screen 17)
- ㉑ Press [Mode 2] to see Screen 18. If “ON” is displayed, the pre-picking will be done when the document is fed. If “OFF” is displayed, it wouldn’t. The “ON” or “OFF” status flips each time you press [Mode 1]. The status will be set in EEPROM automatically.
- ㉒ If you want to return to Screen 17, press [Mode 2]. When you close the setup mode, go to ⑨.

SETUP MODE

B3.6 Adjusting LCD contrast

When you adjust the LCD contrast, you must set as follows.

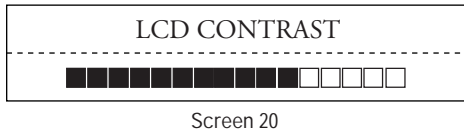
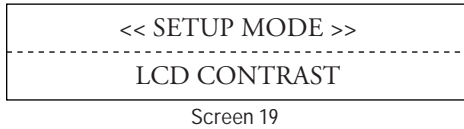

⑳ At Screen 2, press [Mode 1] six times to go to the LCD CONTRAST screen. (Screen 19)

㉑ Press [Mode 2] to see Screen 20. The number of '■' is increased and the LCD contrast is getting darker.

㉒ At Screen 20, the LCD contrast is set in 16 steps each time you press [Mode 1]. When all fields are filled by '■', next pressing [Mode 1] stars from all '□' (The lightest contrast).

㉓ Press [Mode 2] to see Screen 19. The settings are stored to EEPROM.

㉔ When you close the setup mode, go to ⑨.

B3.7 Setting pick speed

When you set the pick speed, you must set as follows.

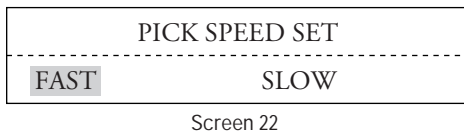
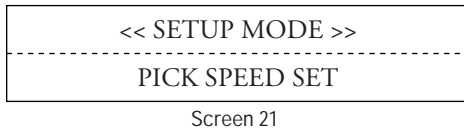

㉕ At Screen 2, press [Mode 1] seven times to go to the PICK SPEED SET screen. (Screen 21)

㉖ Press [Mode 2] to see Screen 22. (The default setting is "FAST".)

If "FAST" is displayed, the pick speed is fast.

If "SLOW" is displayed, the pick speed is slow. The "FAST" or "SLOW" status flips each time you press [Mode 1].

The status will be set in EEPROM automatically.

㉗ If you want to return to Screen 21, press [Mode 2]. When you close the setup mode, go to ⑨.

B3.8 Setting initial value of endorser

When you set the using of endorser and the initial number, you must see Section A2.1 and A2.2 of Appendix A. The details are as follows.

- The using of Endorser (ON/OFF)
The default setting is “OFF” (Endorser is not used.)
- The initial number
The default setting is “00000”. The specifiable range is from 00000 to 65535.

NOTICE: If the specified value exceeds acceptable range, returning to SETUP menu is failed.

<Method of Increment>

In case of the initial value is “00001”.

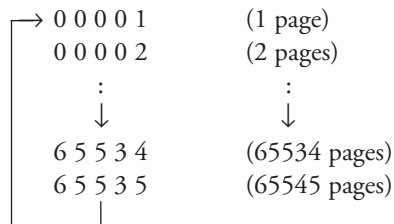

NOTICE: When it is not set “depending on operator panel” by host, no blinking. (You can not change the setting.)

When the setting is set “ON” depending on operator panel the direction of printing is 20 mm from read reference position.

SETUP MODE

B3.9 Setting reset method of endorser

When you set the reset method of endorser, you must see Section A2.3 of Appendix A.

The default setting is “ON” (The print number will be reset when HOPPER EMPTY is detected.).

B3.10 Reset of endorser

When you reset the number to the initial number, you must see Section A2.4 of Appendix A.

B3.11 Reset of ink counter

When you reset the ink counter, you must see Section A2.5 of Appendix A.

B3.12 Setting RS232C transfer rate

When you set the RS232C transfer rate, you must set as follows.

<< SETUP MODE >>

RS232C BAUD

Screen 23

① At Screen 2, press [Mode 1] twelve times to go to the RS232C BAUD screen. (Screen 23)

② Press [Mode 2] to see Screen 24. (The default setting is 4800 bps)

<< SETUP MODE >>

9600 : 4800 : 2400 : 1200

Screen 24

③ At Screen 24, press [Mode 1] until the value you want to change blinks.

④ Press [Mode 2] to see Screen 23. The settings are stored to EEPROM.

⑤ When you close the setup mode, go to 9.

B3.13 Setting picking start time

When you set the picking start time, you must set as follows.

<< SETUP MODE >>

PICK START TIMER

Screen 25

⑥ At Screen 2, press [Mode 1] thirteen times to go to the PICK START TIME screen. (Screen 25)

⑦ Press [Mode 2] to see Screen 26. (The default setting is 1 sec.)

PICK START TIMER

X.X.X S

Screen 26

⑧ At Screen 26, press [Mode 1] until the digit you want to change blinks. Then press [Mode 2] until the digit changes as you want. (The specifiable range is from 0.2 to 29.8 sec. in 0.2 sec. step.)

③⑨ Press [Mode 1] and [Mode 2] at a time to see Screen 25. The settings are stored to EEPROM.

④⑩ When you close the setup mode, go to 9.

B3.14 Setting picking time

When you set the picking time, you must set as follows.

```
<< SETUP MODE >>
-----
PICK TIMER
```

Screen 27

④① At Screen 2, press [Mode 1] fourteen times to go to the PICK TIMER screen. (Screen 27)

④② Press [Mode 2] to see Screen 28. (The default setting is 2 sec.)

```
<< SETUP MODE >>
-----
X X . X S
```

Screen 28

④③ At Screen 28, press [Mode 1] until the digit you want to change blinks. Then press [Mode 2] until the digit changes as you want. (The specifiable range is from 0.5 to 99.5 sec. in 0.5 sec. step.)

④④ Press [Mode 1] and [Mode 2] at a time to see Screen 27. The settings are stored to EEPROM.

④⑤ When you close the setup mode, go to ⑨.

B3.15 Setting time-out limit

When you set the time-out limit, you must set as follows.

```
<< SETUP MODE >>
-----
TIME-OUT SET
```

Screen 29

④⑥ At Screen 2, press [Mode 1] fifteen times to go to the TIME-OUT SET screen. (Screen 29)

④⑦ Press [Mode 2] to see Screen 30. (The default setting is 30 sec.)

```
TIME-OUT SET
-----
X X X X S
```

Screen 30

SETUP MODE

- ④8) At Screen 30, press [Mode 1] until the digit you want to change blinks. Then press [Mode 2] until the digit changes as you want. (The specifiable range is from 1 to 1999 sec. in 1 sec. step.)
- ④9) Press [Mode 1] and [Mode 2] at a time to see Screen 29. The settings are stored to EEPROM.
- ⑤0) When you close the setup mode, go to ⑨.

B3.16 Setting hopper time

When you set the hopper time, you must set as follows.

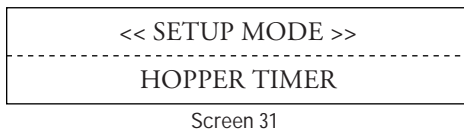

- ⑤1) At Screen 2, press [Mode 1] sixteen times to go to the HOPPER TIMER screen. (Screen 31)

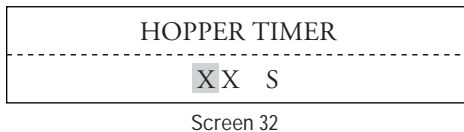

- ⑤2) Press [Mode 2] to see Screen 32. (The default setting is 7 sec.)
- ⑤3) At Screen 32, press [Mode 1] until the digit you want to change blinks. Then press [Mode 2] until the digit changes as you want. (The specifiable range is from 0 to 30 sec. in 1 sec. step.)
- ⑤4) Press [Mode 1] and [Mode 2] at a time to see Screen 31. The settings are stored to EEPROM.
- ⑤5) When you close the setup mode, go to ⑨.

B3.17 Setting heater control

When you set the heater control, you must set as follows.



Screen 33



Screen 34

⑤6 At Screen 2, press [Mode 1] seventeen times to go to the HEATER CONTROL screen. (Screen 33)

⑤7 Press [Mode 2] to see Screen 34. If “ON” is displayed, the heater control will be done. If “OFF” is displayed, warming-up will finish within 30 sec. necessarily. When the heater is broken, please set “OFF”. The “ON” or “OFF” status flips each time you press [Mode 1]. The status will be set in EEPROM automatically.

⑤8 If you want to return to Screen 33, press [Mode 2]. When you close the setup mode, go to ⑨.

SEPARATION PRESSURE ADJUSTMENT

Adjust the separation pressure as follows:

WARNING

Wait at least 3 minutes after turning off the power before replacement.

ACHTUNG

Warten Sie mindestens 3 Minuten nach Ausschalten, bevor Sie mit dem Austausch beginnen.

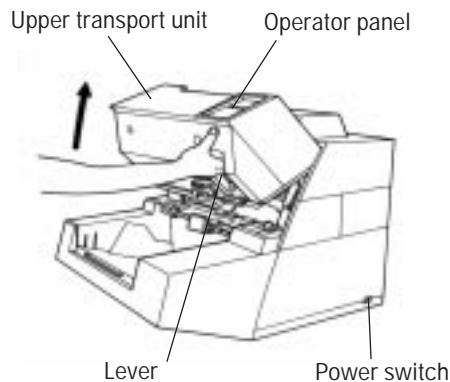

- ① Turn off the power switch. Make sure that the hopper table is at the bottom.
- ② Open the upper transport unit. (See page 4-2)

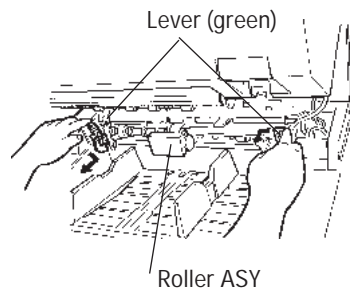

- ③ Disconnect the two relay connectors on the roller ASY.
- ④ Push the two levers (green) towards each other to disengage with the upper locking holes and lower down the two levers until they engage with the two levers locking holes.

SEPARATION
PRESSURE
ADJUSTMENT

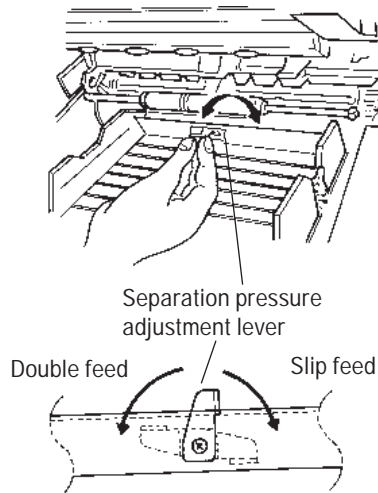
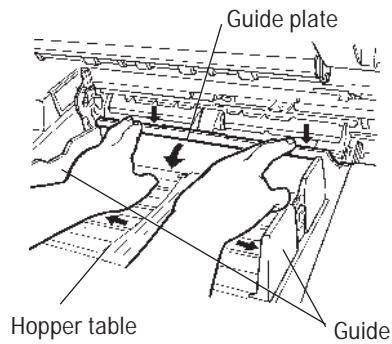

- ⑤ Lift the document sensor unit and keep it at the upper position with one hand and pull the roller ASY out with the other hand.
- ⑥ Move the guide on the hopper table completely to the end.
- ⑦ Hold both ends of the guide plate and press them down to remove the guide.
- ⑧ Adjust the separation pressure by using the separation pressure adjustment lever according to paper feed error as follows:

- Slip feed:
Turn clockwise by 45°. (Increase the separation pressure.)
- Double feed:
Turn counter-clockwise by 45°. (Decrease the separation pressure.)

Notice:

If the paper feed error reccur, try this adjustment again until the lever stops.

Glossary of Terms

A4 size

A standard paper size used in Japan and other countries. Paper is 210 x 297 mm (8.25 x 11.6 inches).

ASCII

The acronym for American Standard Code for Information Interchange. ASCII is a set of 256 codes (numbered 0 to 255) used to communicate information between a computer and another device such as a scanner.

Automatic separation

The image processing method to detect the difference between text and photos and choose the thresholding accordingly. Automatic separation allows the scanner to switch between line mode and half tone mode in one pass.

Automatic start mode

A mode that the scanner starts to read by the command from the host machine.

Bit

The smallest unit of information in computer memory. A bit is a single digit, either a 1 or a 0, in the binary numbering system. Eight bits equal one byte.

Dither

Technique for producing halftone images representing the entire grayscale using two pixel levels black and white.

dpi

Dots per inch.

Endorser

The unit for printing characters before or after scanning. These characters may be used for collation of the documents and the image data. (See Appendix A)

Equipment error

An error which the operator can not recover, such as optical system alarm, temperature alarm and so on. It is necessary to make contact manufacturer's authorized service center for paper repair service.

Error diffusion

High-quality halftone (pseudo-grayscale) image production base on black-and-white pixel binarization. A pixel's optical density and that of adjacent pixels are summed, with black pixels relocated in their order of density as they relate to adjacent pixels.

The purpose of this technique is to minimize the average error between readed and printed densities. Density data for adjacent pixels is modified by diffusing errors on the objective pixel into several pixels, which are than binarized. This maintains high grayscale levels and resolution during reading, while suppressing moire patterns by dotted halftone images such as newspaper photo graphs.

Filtering

The quality of images written in pencil or ballpoint pen and readed depends on the reflective light characteristics of the ink or lead. Dropped pixel's may produce out lines, gaps, or thin, barely connected lines due to even optical density. Filtering detects areas lighter than their surroundings and increases their density to improve image clarity.

Hexadecimal

A base-16 numbering system (also commonly referred to as hex numbers). Since a base-16 system requires 16 digits, numbers 0 through 9 and letters A through F are used. It is convenient to express binary numbers in hexadecimal because fewer digits are required.

Image emphasis

Density is decreased for lighter but not completely white areas adjacent to black areas. Weakening this emphasis eliminates spot noise or produces softened images.

Interface

The connection that allows communication from one part of a system to another. For example, electrical signals are transferred between the computer and scanner over an interface cable.

Inversion (Reverse-image reading)

In reverse-image reading, data is changed from black to white and vice versa.

IPC II

Image processing option of this scanner. (See page 2-6)

Letter size

A standard paper size used in the U.S.A. and other countries. Paper is 8-1/2 x 11 inches (215.9 x 279.4 mm).

Manual mode

A mode that the operator can put the document on the hopper one by one. A document on the hopper can be read automatically.

Manual start mode

A mode that the scanner starts to read by pressing the "START" button on the operator panel.

Mirror image

The readed image is symmetrically flipped to produce a mirror image of the original detected in the main scanning direction.

Noise removal

Isolated noise from an image appearing as black spots in white areas and voids in black areas is removed to improve image quality.

Operator panel

A panel containing the scanner indicators and buttons. The operator panel is used to control scanner operations such as loading document selecting features, and changing setup options.

Outline extraction

The boundary between black and white areas is traced and the outline extracted for closed areas.

RS-232C interface

A type of serial interface. See Serial interface.

Serial interface

A standard computer interface. Information is transferred between devices over a single wire (although other wires are used for control). With a serial interface, an interface cable greater than 3 meters (10 feet) can be used. This is often necessary in networking environments, where the scanner may be shared.

Smoothing

Smoothing eliminates jaggies from slanted lines and curves. Irregular convexities are deleted and irregular concavities filled in. This is useful in OCR applications, for example.

Temporary error

A status which the operator can recover, such as paper jam, hopper empty, cover open, pick miss.

Index

A

Abrasion counter 4-24, B-6
Accessories 7-2
Areas that must not be perforated 6-4
Arrangement of units 1-7
Automatic document feeder (ADF) 1-1, 1-7

B

Basic command/response sequence 3-14
BASIC OPERATION 4-1
Belt Replacement 4-36
Binarization and halftone function 2-1
Button specification and reading mode
setting 4-8
Buzzer functions 4-25

C

charge-coupled device (CCD) image sensors 1-1
CLEANING 8-1
Cleaning Locations and Frequencies 8-1
Cleaning the front-side lamp 8-2
Cleaning the glass surface 8-7
Cleaning the rollers 8-5
Cleaning the sensors 8-7
Cleaning the transport paths 8-6
Cleaning Tools 8-1
CLEAR command 3-19
Closing the Upper Transport Unit 4-2
Commands 3-17
Command/response correspondence 3-91

Command and Response 3-14
Command/response timing chart 3-93
Configuration 1-5
Configuration of the scanner 1-5
Connection specifications 3-1
Consumables 7-1
CONSUMABLES AND ACCESSORIES 7-1
Control circuit (MPU) 1-8
CONTROL command 3-20
Control Interface 3-1
Control unit 1-6

D

Data transfer 3-7
Device and Operator Actions for Equipment
Errors 5-4
Device and Operator Actions for Temporary
Errors 5-1
Document detection sensor 8-8
Document Limitations 6-4
Document Quality 6-2
Document Size 2-1, 6-1
DOCUMENT SPECIFICATION 6-1
Document type 6-2, 6-8
Document width detection sensor 8-7
Driver/receiver 3-3, 3-6
Drop-out Color 6-7
Drop-out color standards 6-7
Duplex (back-side) reading mode 4-20
Duplex (front-side) reading mode 4-15
Duplex circuit (back-side) 1-8
Duplex reading mode 4-7

E

Ejection sensor 8-9

Electrical Specifications 2-2
Endorser A-1
Environmental Specifications 2-2
ERROR PROCESSING AND
RECOVERY 5-1

F

Features 1-4
filtering 1-10

G

General 2-1
Gray scale 2-1
Grounding Color Area 6-6

H

Hopper 1-6
Hopper/stacker capacity 2-1

I

IMAGE CONTROL command 3-38
IMAGE MODE SENSE command 3-52
Image processing circuit 1-8
Ink empty 4-23
INQUIRY command 3-52
Interface 2-1
Interface circuit 1-8
Interface control 1-9
INTERFACE SPECIFICATIONS 3-1
Inversion function 1-10

J

Job Separation Sheet 6-8

L

Lamp Replacement 4-28
LCD display 4-5
Light source 2-1
Loading Document 4-26

M

Main control unit 1-9
Memory board 1-8
Message List 4-25
Mirror image output function 1-10
Motor driver circuit 1-8

N

noise removing 1-10

O

Opening the Upper Transport Unit 4-2
Operation of the control unit 1-8
Operation of the mechanism unit 1-7
Operation Overview 1-7
Operation display 4-23
Operator panel 1-6, 1-8
Operator panel arrangement 4-3
Operator Panel Arrangement and Functions 4-3
Operator panel functions 4-3
Optical unit (back-side) 1-6
Optical unit (front-side) 1-6
Option specifications 2-6
Output density 2-1
Overlay function 1-10
Overview 1-1

P

Pad Replacement 4-38
Physical specifications 2-3
Pick Roller Replacement 4-35
Power supply 1 1-10
Power supply 2 1-10
Power supply unit 1-6, 1-8
Power switch 1-6, 4-1
Power Switch Operation 4-1
Precautions 6-2
PRINT CONTROL command 3-48
Print density measurement 6-7
Print prohibit areas on the front and back surface 6-5
Procedure 8-2

R

READ command 3-51
Read operation 3-85
Reading counter 4-23
Ream weight 6-2
Replacing the back-side lamp 4-31
Replacing the front-side lamp 4-28
Resolution 1-9
Responses 3-61
RETURN SENSE command 3-52
Roller ASY Replacement 4-33
RS-232C interface 1-9

S

Scanning method 2-1
Scanning speed 2-1
SEND DATA command 3-58
SEND DITHER 1 command 3-53
SEND DITHER 2 command 3-55
SENSE command 3-51
Sensor 2-1

Shape 6-8
Simplex (front-side) reading mode 4-9
Simplex reading mode 4-5
Smoothing 1-8
SPECIFICATIONS 2-1
Stacker 1-6
START command 3-51

T

Timing 3-4, 3-12

V

Video circuit (front-side/back-side) 1-8
Video Interface 1-9, 3-5
Video interface signals 3-5



500 sheets hopper 1-1
1000 sheets hopper 1-1

Reader Comment Form

We would appreciate your comments and suggestions for improving this publication.			
Publication No.	Rev. Letter	Title	Current Date
How did you use this publication? <input type="checkbox"/> Learning Reference <input type="checkbox"/> Installing Maintaining <input type="checkbox"/> Sales Operating		Is the material presented effectively? <input type="checkbox"/> Fully Covered <input type="checkbox"/> Well illustrated <input type="checkbox"/> Well Organized <input type="checkbox"/> Clean	
What is your overall rating of this publication? <input type="checkbox"/> Very Good <input type="checkbox"/> Fair <input type="checkbox"/> Very Poor <input type="checkbox"/> Good <input type="checkbox"/> Poor		What is your occupation?	
Your other comments may be entered here. Please be specific and give page, paragraph and line number references where applicable.			
			Your Name & Return Address

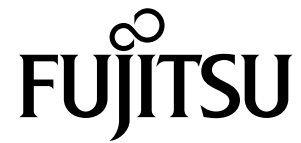

Free Manuals Download Website

<http://myh66.com>

<http://usermanuals.us>

<http://www.somanuals.com>

<http://www.4manuals.cc>

<http://www.manual-lib.com>

<http://www.404manual.com>

<http://www.luxmanual.com>

<http://aubethermostatmanual.com>

Golf course search by state

<http://golfingnear.com>

Email search by domain

<http://emailbydomain.com>

Auto manuals search

<http://auto.somanuals.com>

TV manuals search

<http://tv.somanuals.com>