

Splash 500

THE ULTIMATE CATCH GAME

15 min 5+ 1-5

PLAY: Throw the ball to your friends and the one who catches it gets to add the point value shown to their score. The first one to 500 points wins the game!

SPLASH 500

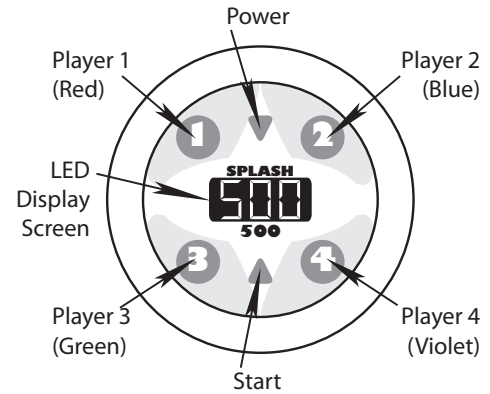

★ IMPORTANT: To begin playing with your Splash 500 ball, you must exit the "try me" mode. Press and hold the 1, 2, 3 and 4 buttons for 5 seconds. The screen will display "Splash 500," then "G1." The game is now set in standard play mode. Begin enjoying Splash 500 - The Ultimate Catching Game! ★

THE GAMES:

1: Classic 500

Players/Teams: 2-5

Goal: Score 500 points before your opponent(s). The ball will randomly generate a point value between 5-100 for each toss.

2: Counter 500

Players/Teams: 2-5

Goal: Score 500 points before your opponent(s). The ball starts at 100 points when thrown then counts down by 10's.

3: Solo 500

Players: 1

Goal: Score 500 points in the fewest number of catches. The ball starts at 100 points, then counts down by 5's.

SPLASH 500™ SETUP:

- 1) Press the Power button to turn the game ON. "Splash 500" will be displayed on the screen. Then "G" (GAME) will display.
- 2) Choose one of the 3 games by pushing the corresponding button: 1 = Classic 500, 2 = Counter 500, 3 = Solo 500. The name of the game will scroll across the screen.
- 3) Press Start to accept. In Classic 500 and Counter 500, the letter "P" (Players) will then be displayed. For Solo 500, skip to step 5.
- 4) Press the 1, 2, 3 or 4 button for the number of players: Player 1 is Red, Player 2 is Blue, Player 3 is Green and Player 4 is Violet. Team play is possible by assigning multiple players to a color.
- 5) "C01" (Catch 01) will display.

GAMEPLAY FUNCTIONS:

- 1) Press Start to begin play and immediately throw the ball.
 - 1 - 2 player games: the players start at one end of the pool. The ball is thrown away from the players. The players race to get the ball.
 - 3 - 5 player games: one player is the designated thrower and will throw the ball towards the other players.
- 2) The first player to get the ball presses any color button to stop the ball's score.
- 3) Press the catching player's color button to confirm the catcher.
- 4) Press the Start button to award the points for that catch. The display will show "CO2." Toss the ball back to the thrower and you are ready for the next round. Repeat all steps until a player wins!

After points from a toss have been awarded or upon the game's completion, players may check individual totals by pressing their corresponding colored button.

WINNING:

The first player who reaches or exceeds 500 points wins! The final score flashes on the display as well as the winner's color will light up. To begin a new game, press and hold the Start button for 2 seconds.

TO TURN OFF:

- 1) Hold the "Power" button for 4 seconds. **OR**
- 2) If the product receives no input for 5 minutes it will turn itself off.

BATTERY REPLACEMENT

- 1: Remove washer screw from the back of the ball.
- 2: Allow the electronic unit to slide out from its housing.
- 3: Remove the four screws on back of the unit.
- 4: Lift lid off unit.
- 5: Remove the three batteries.
- 6: Replace with three new AG13/LR44 Batteries.
- 7: Replace Battery cover.
- 8: Replace the four screws ensuring a water-tight seal.
- 9: Reinsert into housing. Be sure to align the "D" shaped bump on the back of the unit with the "D" shape inside the housing.
- 10: Secure unit back into housing using the washer screw.

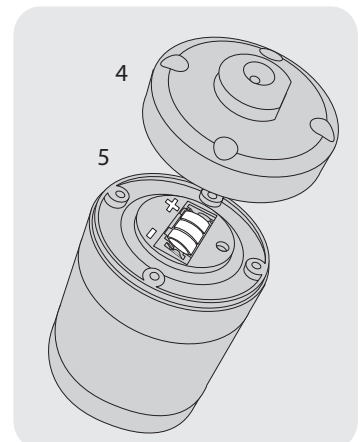
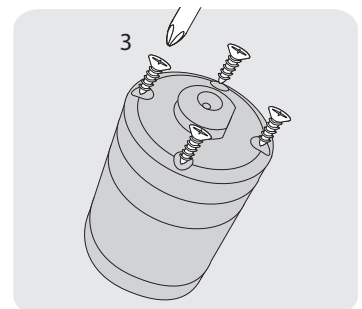
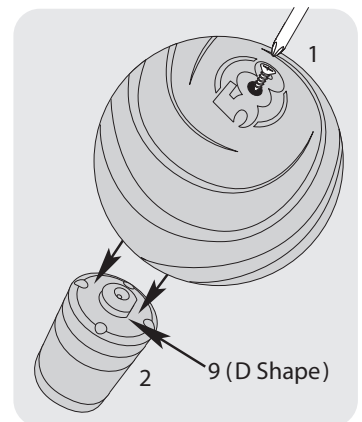

BATTERY SAFETY INFORMATION

- Never mix old and new batteries (replace all batteries at the same time)
- Do not mix alkaline, standard (carbon-zinc), or rechargeable (nickel-cadmium) batteries.
- Always replace all batteries at the same time.
- Alkaline batteries are recommended for best performance.
- Rechargeable batteries are only to be recharged under adult supervision.
- Non-rechargeable batteries are not to be recharged.
- Do not mix different types of batteries.
- Only batteries of the same or equivalent type as recommended are to be used.
- Batteries are to be inserted with correct polarity.
- Exhausted batteries are to be removed from the toy.
- Supply terminals are not to be short-circuited.
- Dispose of batteries safely (Do not dispose of batteries in fire, batteries may explode or leak).

FUNDEX
where fun comes first!

©2006 Fundex Games, Ltd. • P.O. Box 421309 • Indianapolis, IN 46242
www.fundexgames.com

MADE IN CHINA

Questions or comments? Write to us at the address above,
call 1.800.486.9787 or email customerservice@fundexgames.com

In an effort to continually improve our products, items may vary from those shown.

Free Manuals Download Website

<http://myh66.com>

<http://usermanuals.us>

<http://www.somanuals.com>

<http://www.4manuals.cc>

<http://www.manual-lib.com>

<http://www.404manual.com>

<http://www.luxmanual.com>

<http://aubethermostatmanual.com>

Golf course search by state

<http://golfingnear.com>

Email search by domain

<http://emailbydomain.com>

Auto manuals search

<http://auto.somanuals.com>

TV manuals search

<http://tv.somanuals.com>