

FURUNO

OPERATOR'S MANUAL

GPS NAVIGATOR

MODEL GP-30/35

Notice on Mounting the Antenna Unit

When mounting the antenna unit, keep in mind the following points:

- Don't cut the antenna cable.
- To pass the antenna cable through a small hole, unfasten the connector shell.

For detailed information, see this manual.



FURUNO ELECTRIC CO., LTD.
NISHINOMIYA, JAPAN

© **FURUNO ELECTRIC CO., LTD.**

9-52, Ashihara-cho,
Nishinomiya, Japan

Telephone: 0798-65-2111
Telefax: 0798-65-4200

•Your Local Agent/Dealer

All rights reserved.

Printed in Japan

FIRST EDITION : APR. 1997
K : MAR. 1, 2001

(TATA)

PUB. No. OME-43840
GP-30/35



* 00080801200 *



SAFETY INSTRUCTIONS

Safety Instructions for the Operator

WARNING

Do not open the equipment.

Only qualified personnel should work inside the equipment.

Immediately turn off the power at the switchboard if water leaks into the equipment or something is dropped in the equipment.

Continued use of the equipment can cause fire or electrical shock. Contact a FURUNO agent for service.

Do not disassemble or modify the equipment.

Fire, electrical shock or serious injury can result.

Do not place liquid-filled containers on the top of the equipment.

Fire or electrical shock can result if a liquid spills into the equipment.

Immediately turn off the power at the switchboard if the equipment is emitting smoke or fire.

Continued use of the equipment can cause fire or electrical shock. Contact a FURUNO agent for service.

Make sure no rain or water splash leaks into the equipment.

Fire or electrical shock can result if water leaks in the equipment.

WARNING

Keep heater away from equipment.

A heater can melt the equipment's power cord, which can cause fire or electrical shock.

Use the proper fuse.

Fuse rating is shown on the equipment. Use of a wrong fuse can result in equipment damage.

CAUTION

Do not use the equipment for other than its intended purpose.

Use of the equipment as a stepping stool, for example, can result in personal injury or equipment damage.

No one navigation device should ever be solely relied upon for the navigation of a vessel.

Always confirm position against all available aids to navigation, for safety of vessel and crew.

Safety Instructions for the Installer



WARNING

Do not open the cover unless totally familiar with electrical circuits and service manual.

Improper handling can result in electrical shock.

Turn off the power at the switchboard before beginning the installation.

Fire or electrical shock can result if the power is left on.

Do not install the equipment where it may get wet from rain or water splash.

Water in the equipment can result in fire, electrical shock or equipment damage.

Be sure that the power supply is compatible with the voltage rating of the equipment.

Connection of an incorrect power supply can cause fire or equipment damage. The voltage rating of the equipment appears on the label above the power connector.



CAUTION



Ground the equipment to prevent mutual interference.

Observe the following compass safe distances:

	Standard	Steering
Display unit	0.9 m	0.7 m

TABLE OF CONTENTS

FOREWORD	v	5. SETTING, CANCELLING DESTINATION	
1. OPERATIONAL OVERVIEW		5.1 Setting Destination by Cursor	5-1
1.1 System Configuration	1-1	5.2 Setting Destination by Waypoint ...	5-1
1.2 Control Description	1-2	5.3 Setting Route as Destination	5-2
1.3 Turning On and Off the Power	1-3	5.4 Canceling Destination	5-2
1.4 Adjusting Display Dimmer and Contrast	1-3	6. ALARMS	
1.5 Display Modes	1-4	6.1 Arrival Alarm, Anchor Watch Alarm	6-1
1.6 Basic Menu Operation	1-7	6.2 XTE (Cross Track Error) Alarm	6-3
1.7 Simulator Display	1-8	6.3 Speed Alarm	6-3
2. PLOTTER DISPLAY OVERVIEW		7. OTHER FUNCTIONS	
2.1 Enlarging/Shrinking the Display	2-1	7.1 Calculating Range, Bearing and TTG	7-1
2.2 Shifting the Cursor	2-1	7.2 DGPS Setup	7-2
2.3 Shifting the Display	2-2	7.3 Bearing Reference	7-2
2.4 Centering Own Ship's Position	2-2	7.4 Magnetic Variation	7-3
2.5 Changing Track Plotting Interval, Stopping Plotting of Track	2-2	7.5 Geodetic Chart System	7-3
2.6 Erasing Track	2-3	7.6 Units of Measurement	7-4
3. WAYPOINTS (MARKS)		7.7 Displaying Position in LOPs	7-4
3.1 Entering Waypoints	3-1	7.8 Time Difference (using local time)	7-4
3.2 Entering the MOB Mark	3-3	7.9 GPS Setup	7-5
3.3 Displaying Waypoint Name	3-3	7.10 Uploading, Downloading Waypoint, Route Data	7-6
3.4 Editing Waypoints on the WYPTS/MARKS List	3-4	8. MAINTENANCE & TROUBLESHOOTING	
3.5 Deleting Waypoints	3-4	8.1 Maintenance	8-1
4. ROUTES		8.2 Displaying the Message Board	8-1
4.1 Creating a Route	4-1	8.3 Displaying the GPS Satellite Monitor Display	8-1
4.2 Editing a Route	4-2	8.4 Self Test	8-2
4.3 Deleting a Route	4-4	8.5 When "BATTERY ALARM!" Appears	8-3
		8.6 Clearing Data	8-3

9. INSTALLATION

9.1 Installation of Display Unit.....	9-1
9.2 Installation of Antenna Unit.....	9-1
9.3 Wiring	9-2
9.4 Initial Settings	9-3

APPENDIX

SPECIFICATIONS	A-1
EQUIPMENT LISTS	A-3
GEODETIC CHART LIST	A-4
DGPS REFERENCE STATIONS	A-5
LORAN C CHAINS	A-11
DECCA CHAINS	A-12
MENU TREE.....	A-13

OUTLINE DRAWINGS.....	D-1
------------------------------	------------

SCHEMATIC DIAGRAMS	S-1
---------------------------------	------------

FOREWORD

A Word to GP-30/35 Owners

Congratulations on your choice of the FURUNO GP-30/35 GPS Navigator. We are confident you will see why the FURUNO name has become synonymous with quality and reliability.

For over 40 years FURUNO Electric Company has enjoyed an enviable reputation for innovative and dependable marine electronics equipment. This dedication to excellence is furthered by our extensive global network of agents and dealers.

Your navigator is designed and constructed to meet the rigorous demands of the marine environment. However, no machine can perform its intended function unless installed, operated and maintained properly. Please carefully read and follow the recommended procedures for installation, operation, and maintenance.

We would appreciate hearing from you, the end-user, about whether we are achieving our purposes.

Thank you for considering and purchasing FURUNO equipment.

Features

The GP-30/35 GPS Navigator is a totally integrated GPS receiver and video plotter, and consists of a display unit and an antenna unit. The high sensitivity receiver tracks up to eight satellites simultaneously. An 8-state Kalman filter ensures optimum accuracy in determination of vessel position, course and speed.

The main features of the GP-30/35 are

- GP-35 has a built-in DGPS beacon receiver which improves position accuracy.
- A DGPS beacon receiver may be connected to the GP-30.
- Comprehensive navigation data displays
- Storage for 350 waypoints and 30 routes
- Alarms: Arrival, Anchor Watch, Cross Track Error and Ship's Speed
- Man overboard feature records latitude and longitude or LOP (Loran C or Decca) coordinates at time of man overboard and provides continuous updates of range and bearing when navigating to the MOB position.
- Menu-driven operation
- Bright 95 x 60 mm LCD with adjustable contrast and brilliance
- Power consumption is a low 3 W.
- Provision for connection of autopilot (option) – steering data output to autopilot
- Unique "Highway" display provides a graphic presentation of ship's progress toward a waypoint.
- Own ship's position may be shown in latitude and longitude or LOP (Loran C or Decca).
- Waypoint and route data can be uploaded from a PC or downloaded to a PC.

1. OPERATIONAL OVERVIEW

1.1 System Configuration

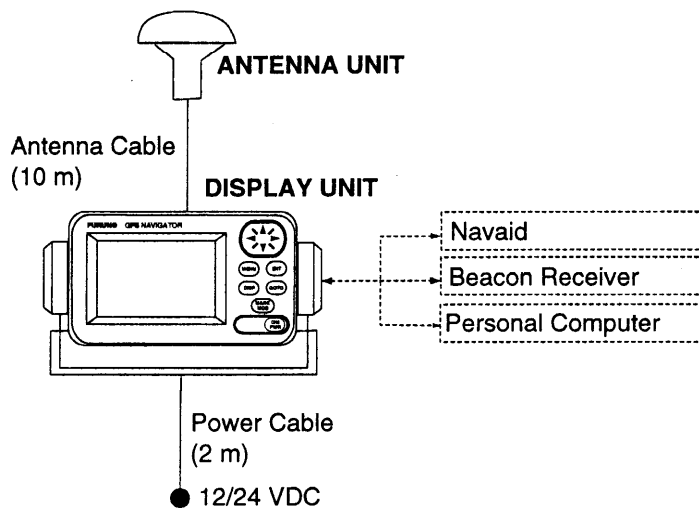

Figure 1-1a GP-30 system configuration

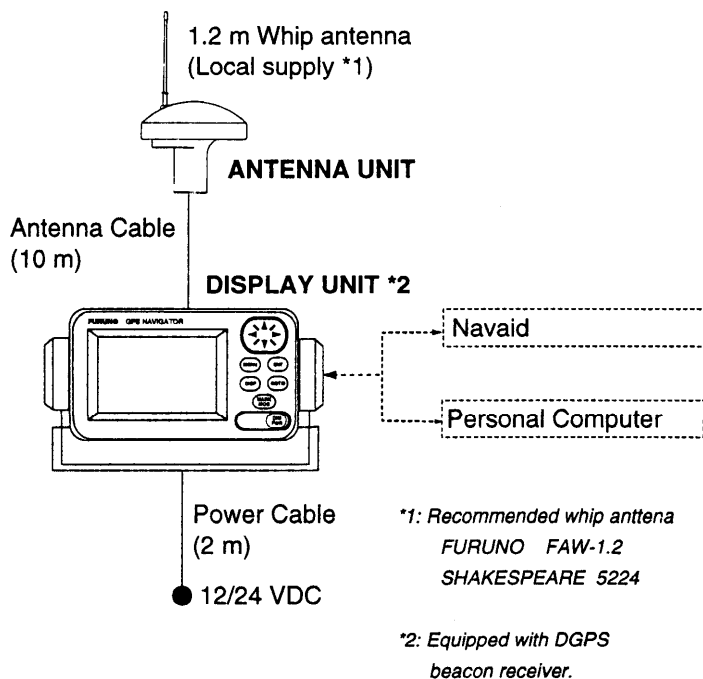

Figure 1-1b GP-35 system configuration

1.2 Control Description

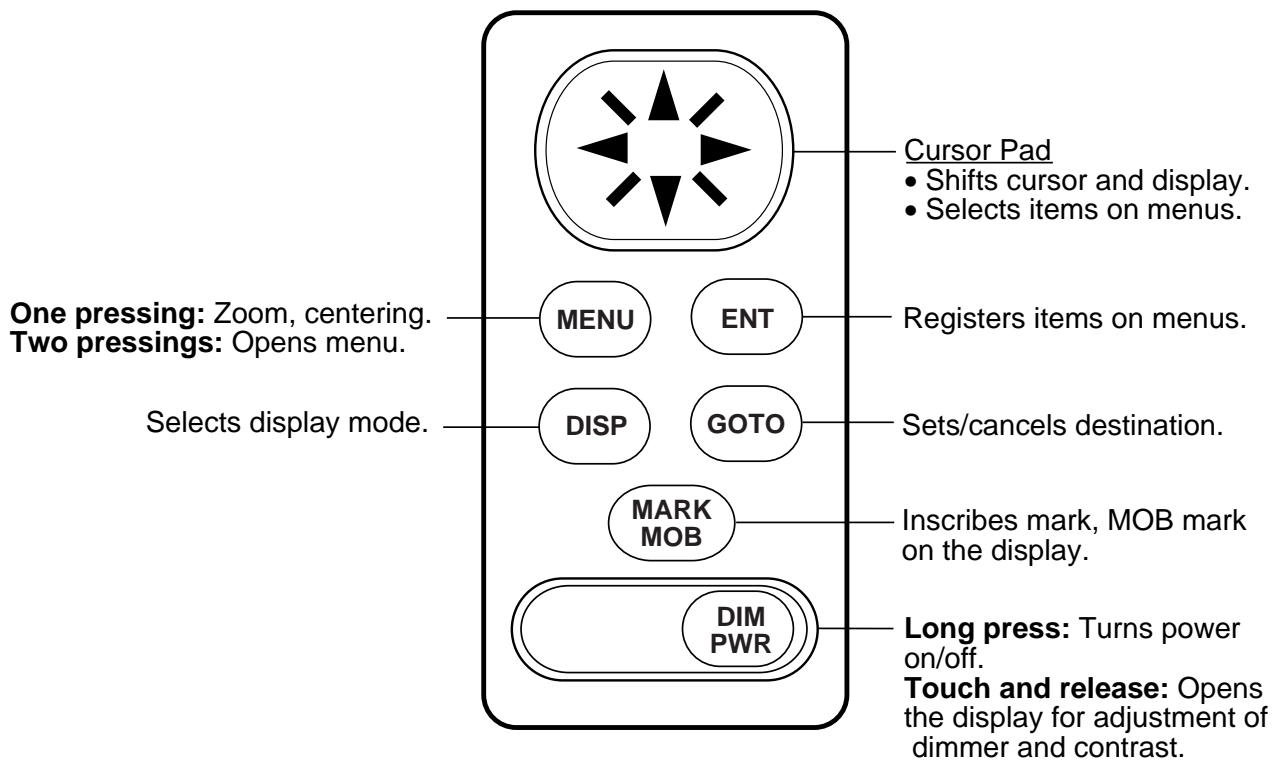

Figure 1-2 Control panel

1.3 Turning On and Off the Power

Turning on the power

Press and hold down the [DIM/PWR] key. The unit beeps and then starts up with the last-used display mode.

The GP-30/35 takes about two minutes to find its position when turned on for the very first time. This is because the default position is San Francisco, USA. If you want to lessen the time needed to find position you may enter your position manually on the SIMULATOR screen of the SYSTEM SETUP MENU, referring to 1.7 Simulator Display on page 1-8. Thereafter it takes about 20 seconds to find position each time the power is turned on.

If position could not be found, “GPS NO FIX” appears at the center of the display.

When the satellite signal is being received normally, the GP-30/35 displays various abbreviations at the top left-hand corner of the display which show receiver status. Table 1-1 shows these abbreviations and their meanings.

Table 1-1 Display abbreviations

Indication	Meaning
2D	Normal 2D GPS position fix
DOP	GPS position fix with DOP more than 4
3D	Normal 3D GPS position fix
DOP	DOP (DOP more than 6)
D2D	Normal differential GPS position fix
DOP	Differential GPS position fix with DOP more than 4
D3D	Normal 3D differential GPS position fix
DOP	Differential GPS position fix with DOP more than 6
SIM	Simulation mode.

Turning off the power

Press and hold down the [DIM/PWR] key until the screen goes blank.

1.4 Adjusting Display Dimmer and Contrast

1. Press the [DIM/PWR] key. The display shown in Figure 1-3 appears.

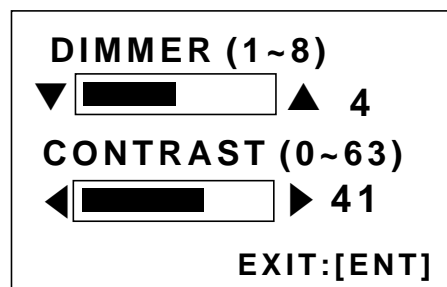

Figure 1-3 Screen for adjustment of display dimmer and contrast

2. To adjust the dimmer, press ▲ or ▼. Current setting is shown to the right of “▲”.
3. To adjust the contrast, press ◀ or ▶. Current setting is shown to the right of “▶”.
4. Press the [ENT] key to finish.

1.5 Display Modes

The GP-30/35 has four display modes: Plotter Display, Highway Display, Steering Display, and Nav Data Display. Press the [DISP] key to select a display mode. Each time the key is pressed, the display mode changes in the sequence shown below.

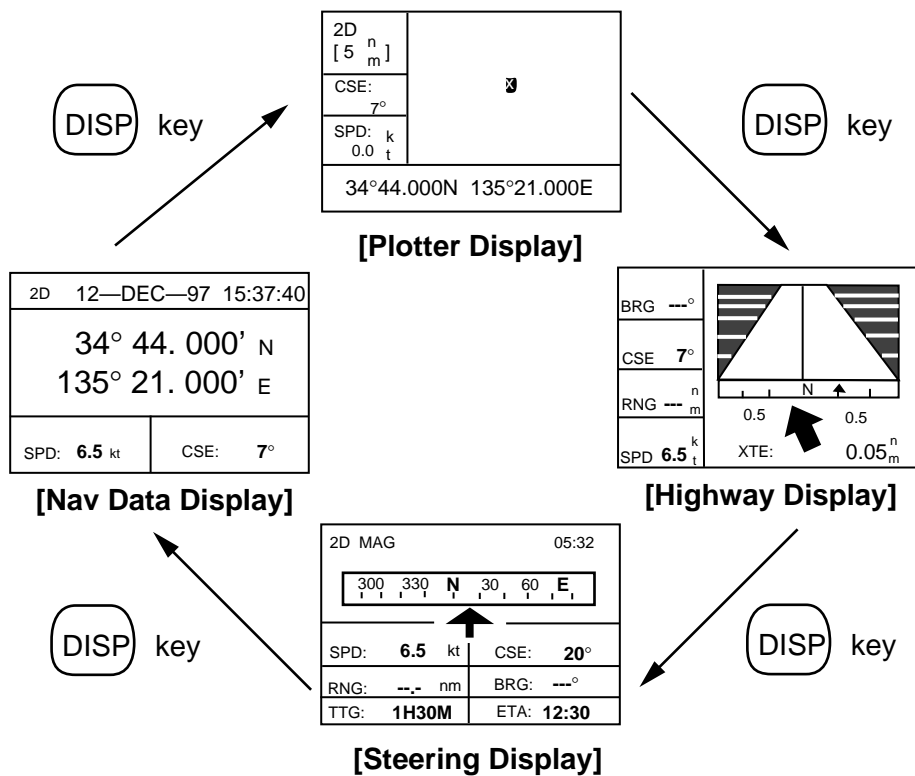

Figure 1-4 Display modes

Note: Position data can be shown in latitude and longitude or LOP (Loran C or Decca).

Plotter Display

The plotter display plots own ship's track and shows position, course, speed, and horizontal display range setting.

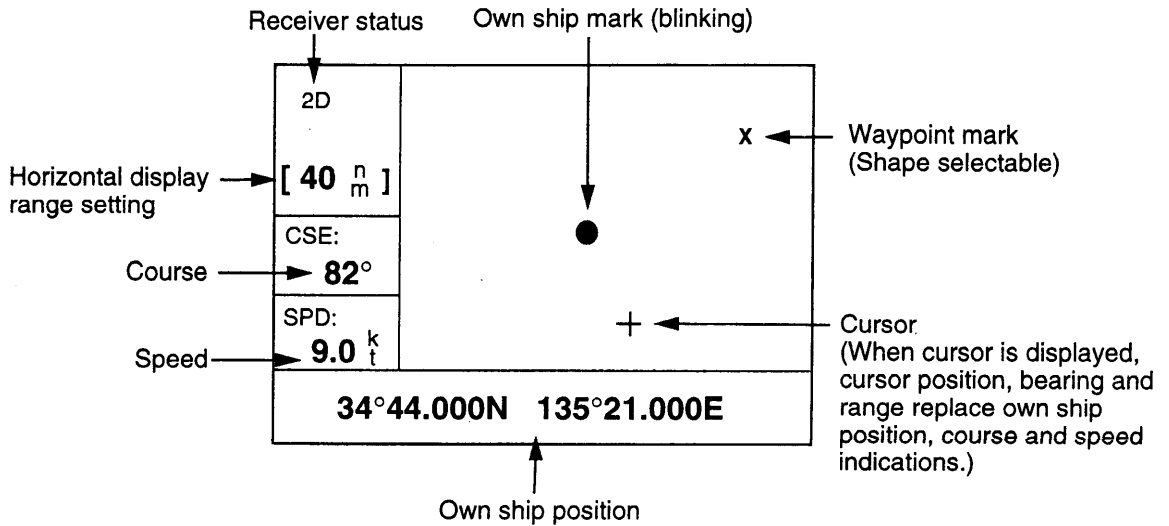

Figure 1-5 Plotter display

Highway Display

The highway display provides a 3-D view of own ship's progress toward a waypoint and displays navigation data.

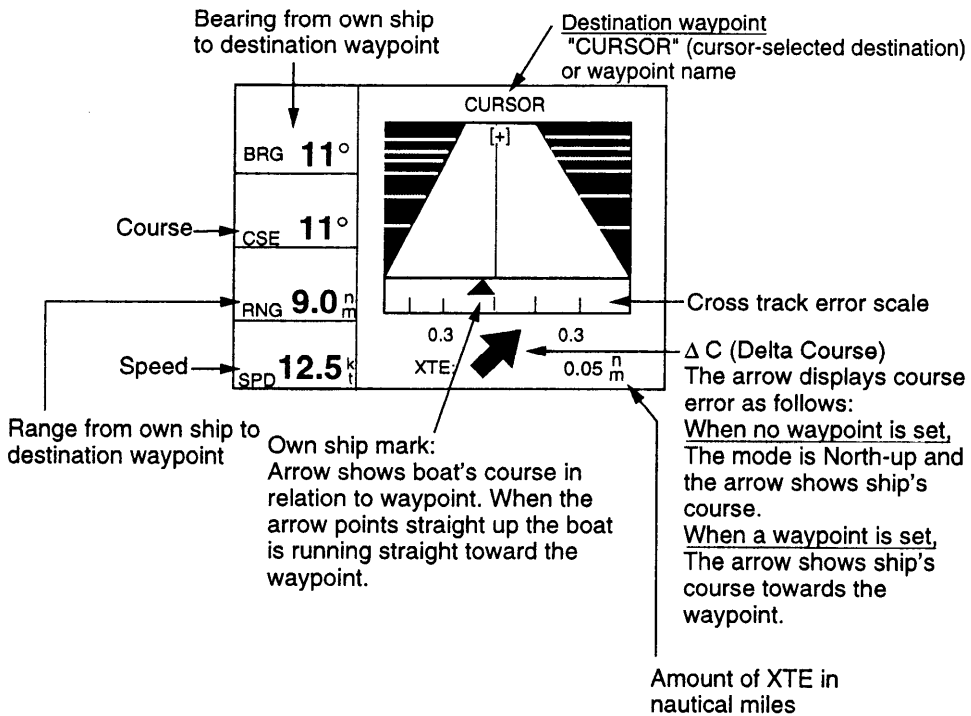

Figure 1-6 Highway display

Steering Display

The steering display provides steering information such as range, bearing and ETA to destination, course, and speed.

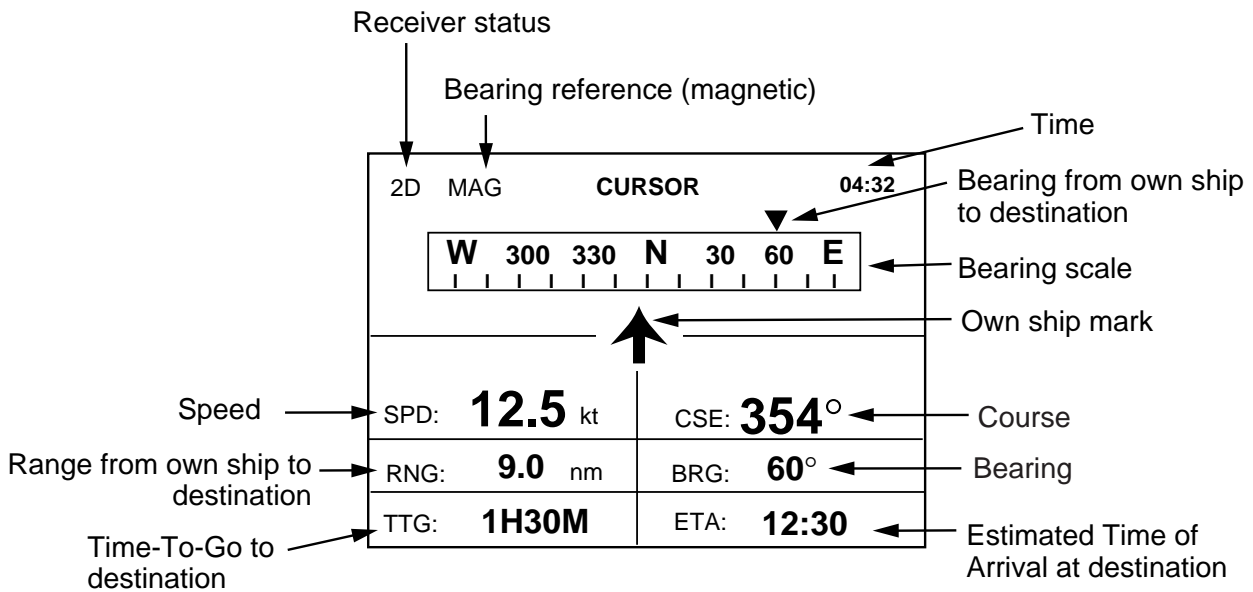

Figure 1-7 Steering display

Nav Data Display

The Nav Data display shows position in latitude and longitude (or TDs), course, speed, date and time.

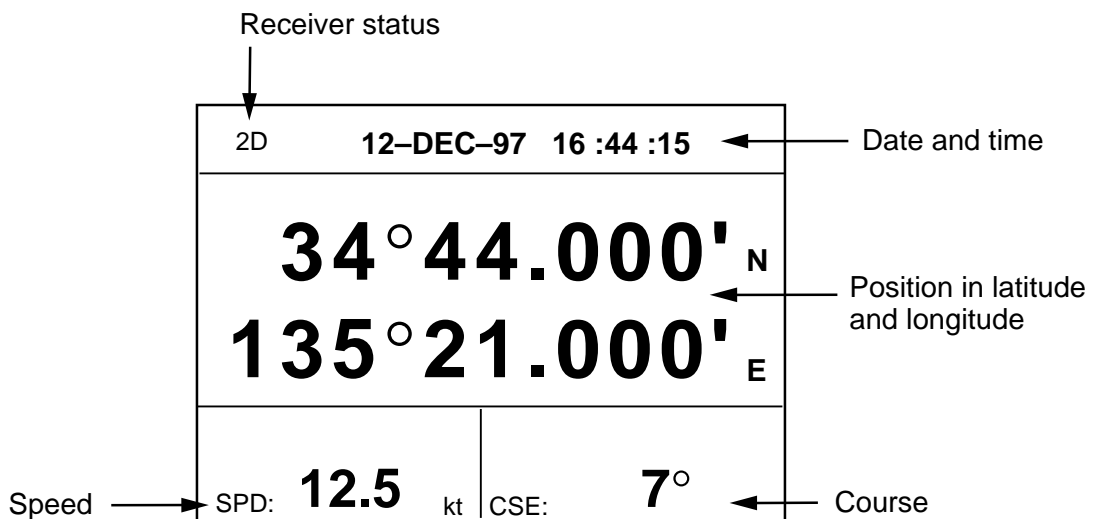

Figure 1-8 Nav data display

1.6 Basic Menu Operation

Most operations of the GP-30/35 are carried out through the menu. Below is a quick introduction to how to select a menu and change menu settings. If you get lost in operation, press the [MENU] key to return to the MAIN MENU. A complete menu tree appears on page A-12.

1. Press the [MENU] key twice to display the MAIN MENU.

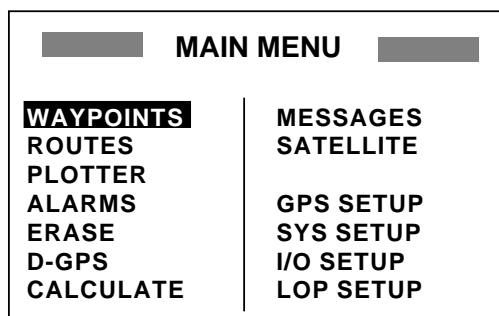

Figure 1-9 MAIN MENU

2. Operate the Cursor Pad to select a menu and press the [ENT] key. For example, select PLOTTER and press the [ENT] key.

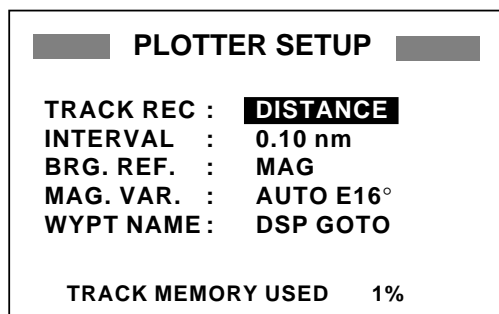

Figure 1-10 PLOTTER SETUP menu

3. Press ▲ or ▼ to select menu item. For example, select the TRACK REC line.
4. Press the [ENT] key. A window showing options appears. (The figure below shows the options available for TRACK REC.)

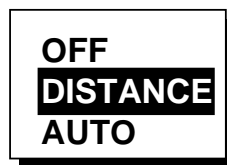

Figure 1-11 Options of TRACK REC

5. Press ▲ or ▼ to select option desired.
6. Press the [ENT] key.
7. Press the [MENU] key twice to finish.

How to enter numeric, character data

In some instances it is necessary to enter numeric or character data. The example below shows how to enter a time difference of –6:30, to use local time instead of UTC time.

1. Press the [MENU] key twice to display the MAIN MENU.
2. Select SYS SETUP and press the [ENT] key.

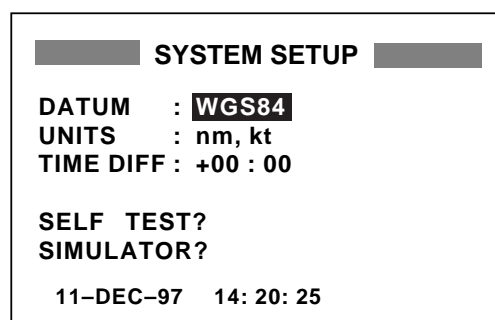

Figure 1-12 SYSTEM SETUP menu

3. Press ▼ to select the TIME DIFF line.
4. Press the [ENT] key. A cursor circumscribes "+". The cursor selects the data to change.

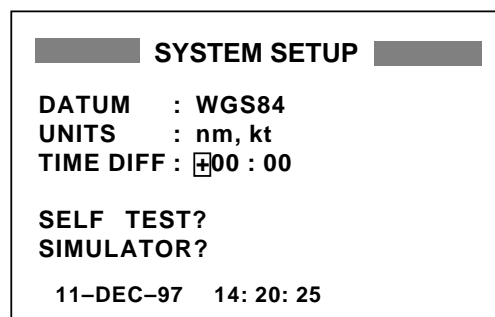

Figure 1-13 SYSTEM SETUP menu, TIME DIFF line selected

5. Press ▲ to display “-”.
6. Press ► to send the cursor to the next digit.
7. Press ▲ or ▼ to display 0.
8. Press ► to send the cursor to the next digit.

9. Press ▲ or ▼ to display 6.
10. Press ► to send the cursor to the next digit.
11. Press ▲ or ▼ to display 3.
12. Press ► to send the cursor to the last digit.
13. Press ▲ or ▼ to display 0.
14. Press the [ENT] key.
15. Press the [MENU] key twice to finish.

1.7 Simulator Display

The simulator display provides simulated operation of this unit. You may set the speed manually and the course manually or automatically. All controls are operative – you may enter marks, set destination, etc.

1. Press the [MENU] key twice to display the MAIN MENU.
2. Select SYS SETUP and press the [ENT] key.

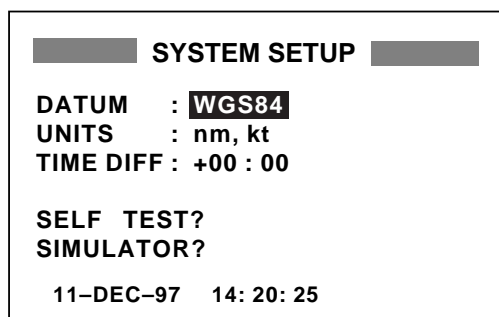

Figure 1-14 SYSTEM SETUP menu

3. Select SIMULATOR? and press the [ENT] key.

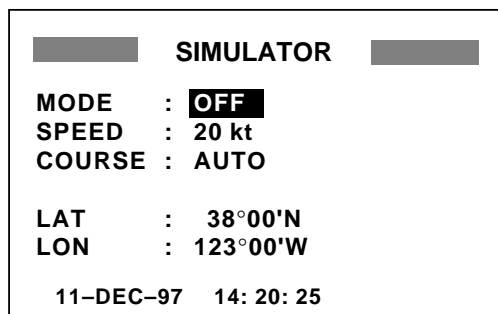

Figure 1-15 SIMULATOR menu

4. Press the [ENT] key.
5. Select ON and press the [ENT] key.
6. Press the [ENT] key, enter speed to use for the simulation with the Cursor Pad, and press the [ENT] key.
7. Press the [ENT] key.
8. Select course entry method (AUTO or MANU) and press the [ENT] key. For manual entry of course, press the [ENT] key again, enter course with the Cursor Pad, and press the [ENT] key again. (The AUTO course tracks a circular course.)
9. Press the [ENT] key, enter latitude (usually current latitude) with the Cursor Pad, and press the [ENT] key.
10. Press the [ENT] key, enter longitude (usually current longitude), and press the [ENT] key.
11. Press the [MENU] key twice.
12. Select the PLOTTER display with the [DISP] key. SIM appears at the upper left-hand corner when the simulator display is active.

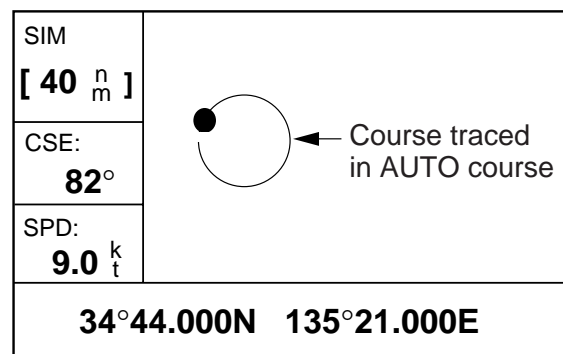

Figure 1-16 Simulator display, auto course selected

13. To turn off the simulator display, select OFF on the MODE line of the SIMULATOR menu, press the [ENT] key, and press the [MENU] key twice to finish.

Note: If the power is reset while the simulator display is in use, the indication SIMULATION MODE appears in addition to the indication SIM.

2. PLOTTER DISPLAY OVERVIEW

2.1 Enlarging/Shrinking the Display

You may enlarge and shrink the display on the Plotter and Highway displays. The horizontal range in the Plotter display is available among 0.2, 0.5, 1, 2, 5, 10, 20, 40, 80, 160 and 320 nautical miles. The horizontal range in the Highway display is available among 0.2, 0.4, 0.8, 1, 2, 4, 8, 16 nautical miles.

1. Press the [MENU] key. ZOOM IN/OUT? appears in reverse video.

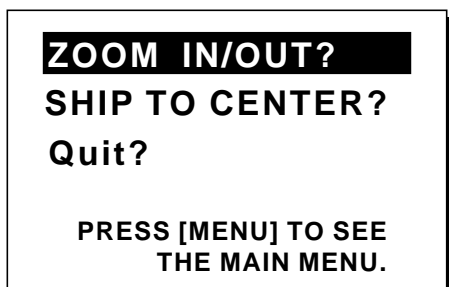

Figure 2-1 Zoom, ship centering window

Note: The prompt SHIP TO CENTER? does not appear in the Highway display mode.

2. Press the [ENT] key. The window changes as below.

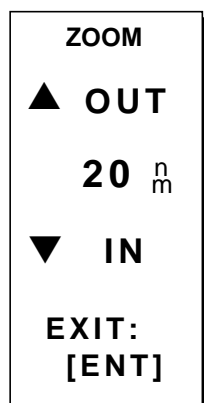

Figure 2-2 Zoom window

3. Press ▲ (enlarge) or ▼ (shrink) to select range desired.
4. Press the [ENT] key to finish.

2.2 Shifting the Cursor

Operate the Cursor Pad to shift the cursor. The cursor moves in the direction of the arrow or diagonal pressed on the Cursor Pad.

Cursor state and data

Cursor state determines what data is shown on the display.

Cursor turned on

Cursor position is displayed in latitude and longitude or LOPs (depending on menu setting) at the bottom of the Plotter display when the cursor is on. The range and bearing from own ship to the cursor appear at the left-hand side of the display.

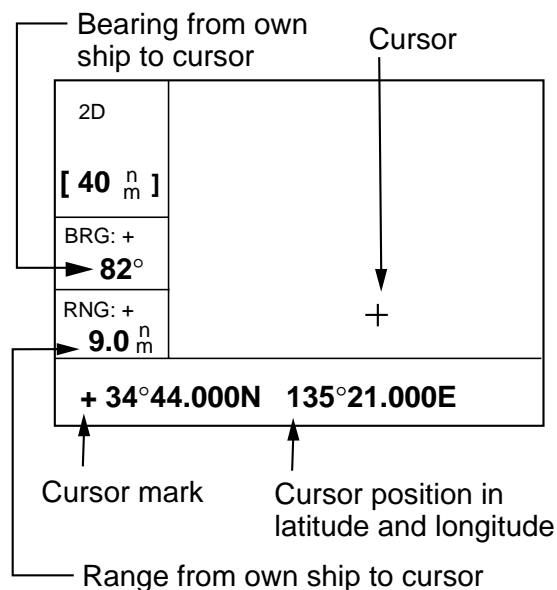

Figure 2-3 Data displayed on the Plotter display when the cursor in on

Cursor turned off

The cursor is erased when there is no Cursor Pad operation for about five seconds. Ship's position, speed and course appear at the left side of the Plotter display when the cursor is off.

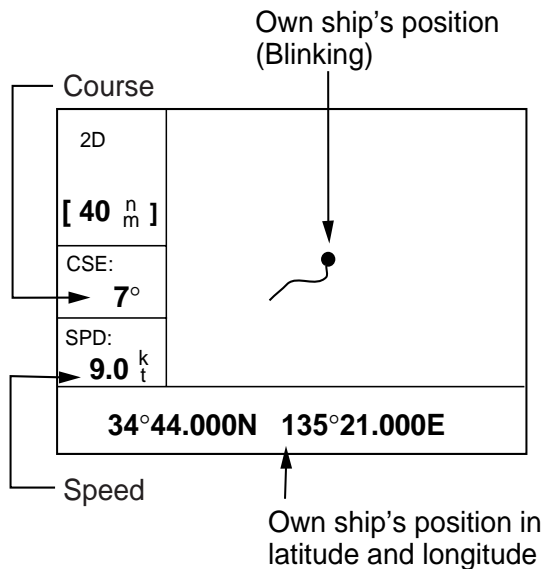

Figure 2-4 Data displayed on the Plotter display when the cursor is turned off

2.3 Shifting the Display

The display can be shifted on the Plotter display. Operate the Cursor Pad to place the cursor at an edge of the screen. The display shifts in the direction opposite to Cursor Pad operation.

When own ship tracks off the display it is automatically returned to the screen center.

2.4 Centering Own Ship's Position

1. Press the [MENU] key.
2. Select SHIP TO CENTER?.
3. Press the [ENT] key.

2.5 Changing Track Plotting Interval, Stopping Plotting of Track

In drawing track, first the ship's position (fed from the GPS receiver) is stored into the memory at an interval of distance or automatic recording. For distance, a shorter interval provides better reconstruction of the track, but the storage time of the track is reduced. When the track memory becomes full, the oldest track is erased to make room for the latest.

1. Press the [MENU] key twice.

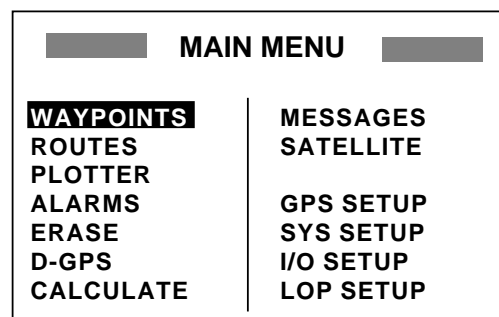

Figure 2-5 MAIN MENU

2. Select PLOTTER.
3. Press the [ENT] key.

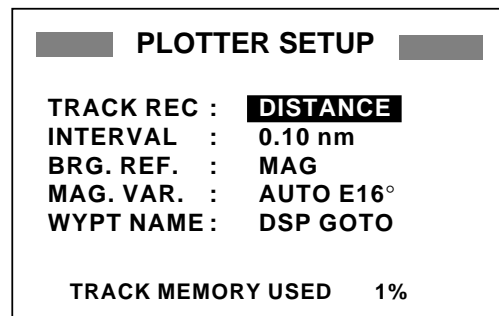

Figure 2-6 Plotter setup menu

- The cursor should be on the TRACK REC line. Press the [ENT] key. The track recording method selection window appears.

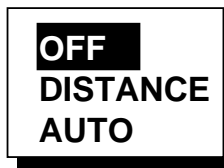

Figure 2-7 Track recording method selection window

- Select OFF, DISTANCE or AUTO and then press the [ENT] key.

OFF: Track is neither recorded or plotted. This setting is useful when you do not need to record track, for example, when returning to port.

DISTANCE: Track is recorded and plotted at the distance interval set.

AUTO: Plotting and recording interval changes with chart scale selected.

If you selected DISTANCE, enter the recording interval as follows:

- Press the [ENT] key.
- Press ◀ or ▶ to select digit to change.
- Press ▲ or ▼ to change value.
- Press the [ENT] key after setting.

- Press the [MENU] key twice to finish.

2.6 Erasing Track

All track can be erased. Track cannot be restored once erased. Be absolutely sure you want to erase all track.

- Press the [MENU] key twice.
- Select ERASE and press the [ENT] key. The ERASE menu appears.

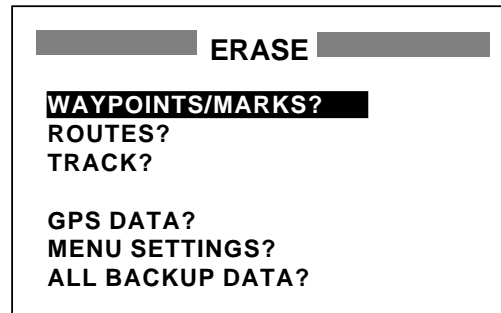

Figure 2-8 ERASE menu

- Select TRACK? and press the [ENT] key. The message shown in Figure 2-9 appears.

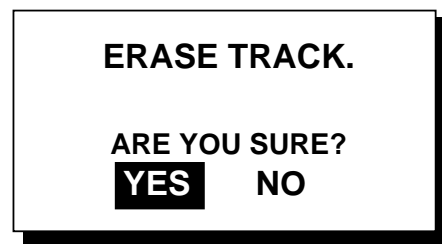

Figure 2-9 Prompt for erasure of track

- Press the [ENT] key to erase all track.
- Press the [MENU] key twice to finish.

3. WAYPOINTS (MARKS)

3.1 Entering Waypoints

In navigation terminology a waypoint is a particular location on a voyage whether it be a starting, intermediate or destination waypoint. The GP-30/35 can store 350 waypoints. Waypoints can be entered on the Plotter display four ways:

- By cursor
- At own ship's position
- Through the menu (L/L or LOP)
- By MOB position

Entering a waypoint by the cursor

1. On the Plotter display, operate the Cursor Pad to place the cursor on the location you want to make a waypoint.
2. Press the [ENT] key. The following window appears.

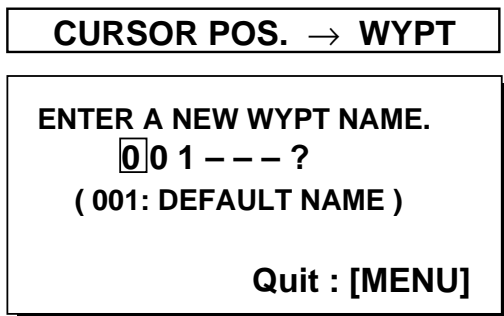

Figure 3-1 Waypoint entry window-1

3. The cursor is on the second line of the display. This is where you may enter waypoint name, which may consist of six characters. (If you would rather have the unit automatically number your waypoints, and you do not need to change mark shape or enter a comment, press the [ENT] key twice to finish.) To enter KOBE as the waypoint name, for example, do the following:

- a) Press ▲ or ▼ to display K.
- b) Press ► to move the cursor to the next column and press ▲ or ▼ to display O.

- c) Press ► to move the cursor to the next column and press ▲ or ▼ to display B.
- d) Press ► to move the cursor to the next column and press ▲ or ▼ to display E.
- e) Press the [ENT] key. The following window appears.

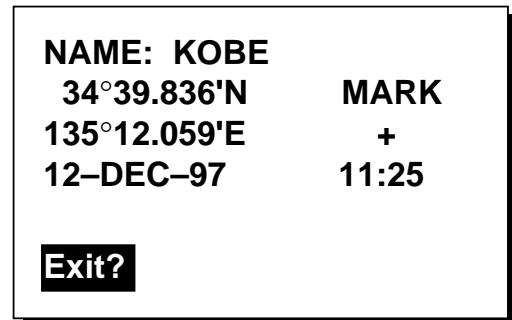

Figure 3-2 Waypoint entry window-2

4. This window is where you can select mark shape and enter a comment. (If you do not need to change mark shape or enter a comment, select Exit? and press the [ENT] key to finish.)

- a) Operate the Cursor Pad to place the cursor under MARK.
- b) Press the [ENT] key.
- c) Select mark desired with ▲ or ▼.

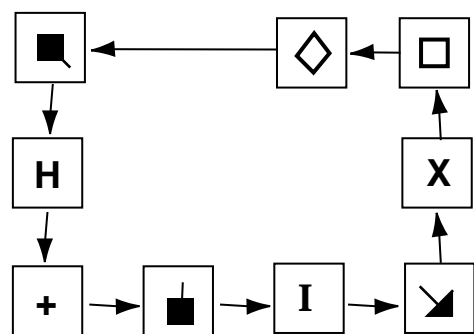

Figure 3-3 Mark sequence

- d) Press the [ENT] key.
- e) The cursor is on the date/time line. Press the [ENT] key.

- f) Enter a comment (max. sixteen characters) with the Cursor Pad and press the [ENT] key. To create a space select “blank” character. To remove all characters which follow the cursor, select the underline.
- g) Press the [ENT] key.
- h) Press the [ENT] key again to finish.

Entering a waypoint at own ship's position

1. Press the [MARK/MOB] key. The following window appears.

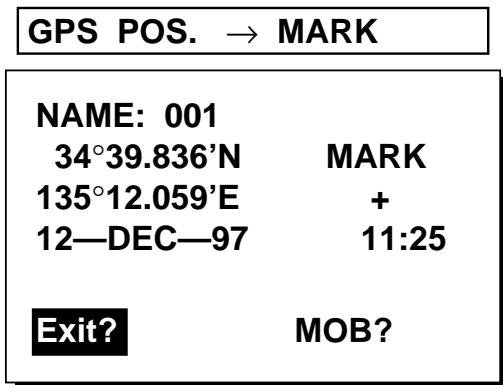

Figure 3-4 Own ship's position window

2. If you do not need to change mark shape or enter a comment, press the [ENT] key to finish.
3. If you want to change mark shape, place the cursor under MARK. Press the [ENT] key, select mark shape, and press the [ENT] key again.
4. The cursor is on the date/time line. To change the date to a comment, press the [ENT] key, enter a comment, and press the [ENT] key again.
5. The cursor is on Exit?. Press the [ENT] key to finish.

Note: The name of a waypoint entered at own ship's position cannot be changed when entered. However, it can be changed on the WYPTS/MARKS menu.

Entering a waypoint through the menu

1. Press the [MENU] key twice.
2. Select WAYPOINTS.
3. Press the [ENT] key. The WYPTS/MARKS menu appears.

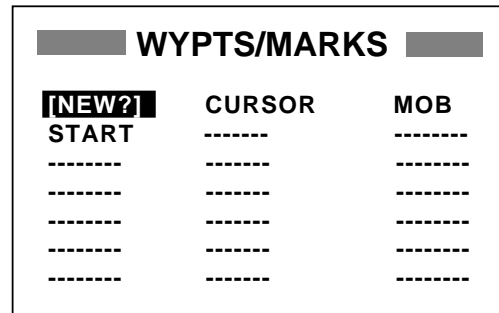

Figure 3-5 WYPTS/MARKS menu

4. Press the [ENT] key.

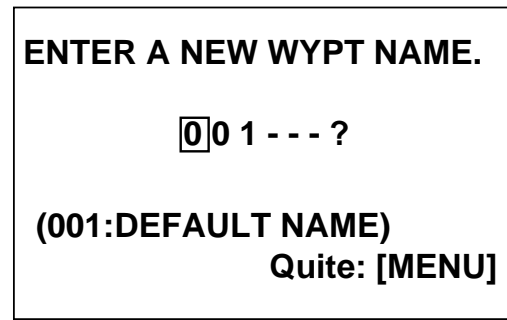
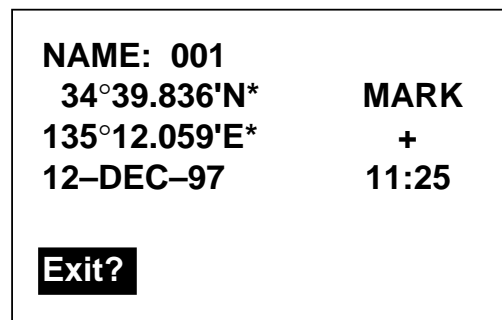

Figure 3-6 Screen for entering waypoint name

5. Enter name (if desired) and press the [ENT] key.



* Present position

Figure 3-7 Screen for entering waypoint latitude and longitude

6. Operate the Cursor Pad to place the cursor on the second line (latitude) and press the [ENT] key. Enter latitude (LOP) and press the [ENT] key.

7. Press the [ENT] key, enter longitude (LOP) in similar fashion and press the [ENT] key.

Note: To enter position by LOPs, see “7.8 Displaying Position in LOPs.”

8. To change mark shape, press the [ENT] key, select mark desired and press the [ENT] key.

9. To change date and time to the comment of your choice, press the [ENT] key, enter comment, and press the [ENT] key again.

10. The cursor is on Exit?. Press the [ENT] key.

11. Press the [MENU] key twice to finish.

3.2 Entering the MOB Mark

The MOB mark denotes man overboard position. Only one MOB mark may be entered. Each time the MOB mark is entered the previous MOB mark and its position data are written over.

1. Press the [MARK/MOB] key.

NAME: 001	
34°44.000'N	MARK
135°21.000'E	x
12-DEC-97	11:25
Exit?	MOB?

Figure 3-8 MOB window

2. Press ► to select MOB?.

Note: Pressing the [ENT] key instead of ► at step 2 saves the position as a waypoint.

3. Press the [ENT] key.

SAVED TO MOB.	
GO TO MOB ?	
ARE YOU SURE?	
YES	NO

Figure 3-9 MOB window-2

4. To set MOB position as destination, press the [ENT] key. Then, the Plotter display marks MOB position.

Note: Selecting “NO” at step 4 saves the position as a waypoint.

2D	
[40 ⁿ / _m]	
BRG: 72°	
RNG: 54.5 ⁿ / _m	
34°44.000N 135°21.000E	

Figure 3-10 MOB set as destination

3.3 Displaying Waypoint Name

You may display all waypoint names or only the GOTO waypoint name as follows:

1. Press the [MENU] key twice.
2. Select PLOTTER and press the [ENT] key.
3. Place the cursor on the WYPT NAME line and press the [ENT] key. The following window appears.

DSP GOTO
DSP ALL

Figure 3-11 DSP GOTO, DSP ALL selection window

4. Select DSP GOTO or DSP ALL and press the [ENT] key.
5. Press the [MENU] key twice to finish.

3.4 Editing Waypoints on the WYPTS/MARKS List

Waypoint position, waypoint name, mark shape and comment can be edited on the WYPTS/MARKS List.

1. Press the [MENU] key twice.
2. Select WAYPOINTS and press the [ENT] key.
3. Select waypoint to edit and press the [ENT] key.
Note: You cannot edit CURSOR, MOB or START.
4. To change waypoint name or create a new waypoint from an existing one, first select the NAME line and press the [ENT] key.

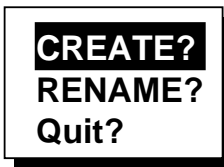

Figure 3-12 CREATE, RENAME prompt

6. Select objective and press the [ENT] key.
7. Change position, mark shape, comment as desired.
8. Select Exit? and press the [ENT] key.
9. Press the [MENU] key twice to finish.

3.5 Deleting Waypoints

1. Press the [MENU] key twice.
2. Select ERASE and press the [ENT] key.

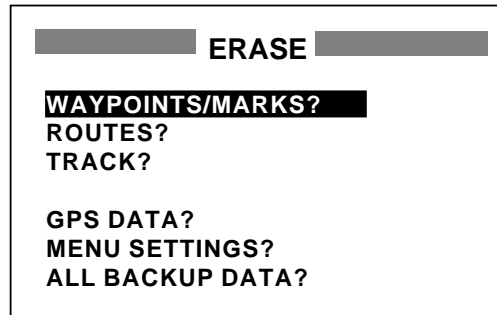

Figure 3-13 ERASE menu

3. The cursor is on the WAYPOINTS/MARKS? line. Press the [ENT] key.

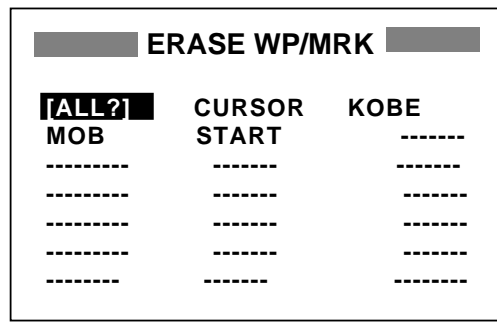

Figure 3-14 ERASE WP/MRK display

4. Select the waypoint you want to erase.
Note: You cannot erase CURSOR, MOB or START.
5. Press the [ENT] key.

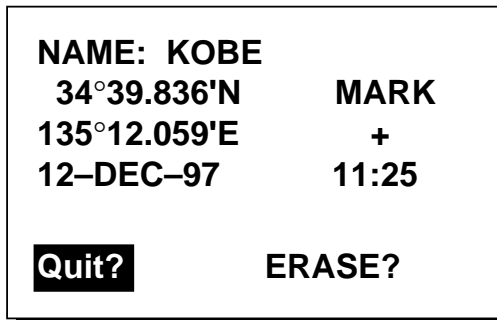

Figure 3-15 ERASE prompt

6. Select ERASE? and press the [ENT] key.
7. Press the [MENU] key twice to finish.

4. ROUTES

In many cases a trip from one place to another involves several course changes, requiring a series of route points (waypoints) which you navigate to, one after another. The sequence of waypoints leading to the ultimate destination is called a **route**. The GP-30/35 can automatically advance to the next waypoint on a route, so you do not have to change the destination waypoint repeatedly.

4.1 Creating a Route

You can store up to 30 routes and each route may contain up to 30 waypoints. The unit numbers routes from 01 to 30. The easiest way to create a route is to enter appropriate waypoints beforehand and select them from the waypoint list. However, you may also enter waypoints while creating a route.

Note: Be sure to record all important routes in a separate log. This unit is not a fail-safe record keeping device.

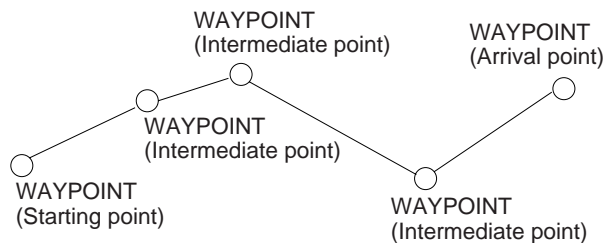

Figure 4-1 Sample route

Registering a route

The procedure which follows describes how to create a route from two waypoints in Japan, KOBE and OSAKA.

1. Press the [MENU] key twice.
2. Select ROUTES.
3. Press the [ENT] key. The screen shown in Figure 4-2 appears.

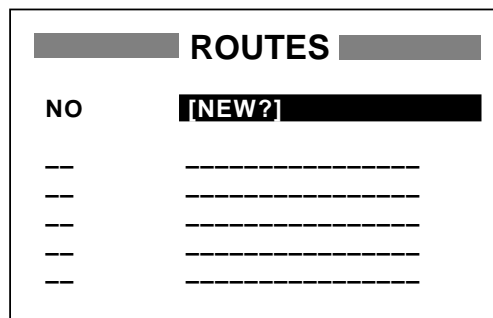

Figure 4-2 Routes menu

4. Press the [ENT] key. The screen shown in Figure 4-3 appears.

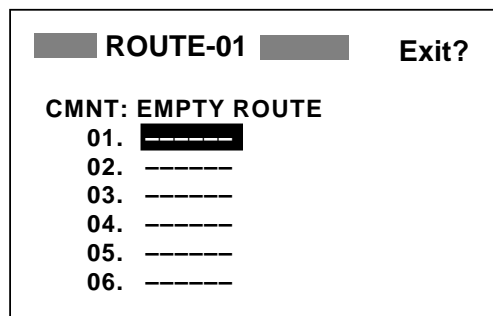

Figure 4-3 Screen for entering route

5. Press the [ENT] key.
6. Press ▲ or ▼ to display starting waypoint. (In the example, KOBE.)
7. Press the [ENT] key twice. The cursor moves to the head of next line.
8. Repeat steps 6 and 7 until you have entered all intermediate waypoints desired.
9. Finally, select arrival point. (In the example, OSAKA.)

10. Select Exit?.

11. Press the [ENT] key to register the route.

Then, the display shows the names of starting and arrival waypoints next to route number.

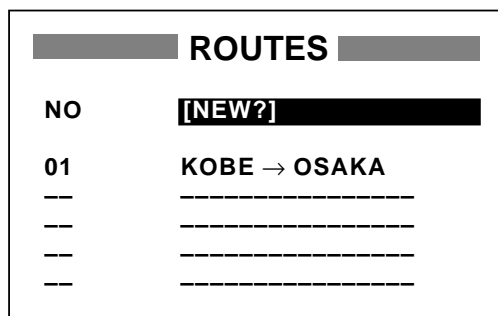

Figure 4-4 ROUTES list

12. Press the [MENU] key twice to finish.

4.2 Editing a Route

Replacing a waypoint in a route

1. Press the [MENU] key twice.
2. Select ROUTES and press the [ENT] key.
3. Select the route to edit.
4. Press the [ENT] key.
5. Place the cursor on the waypoint to replace.
6. Press the [ENT] key. The following window appears.

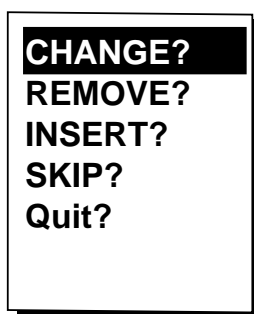

Figure 4-5 Window for editing waypoint in route

7. CHANGE? is selected; press the [ENT] key.

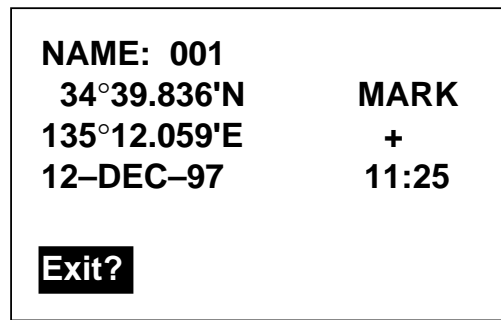

Figure 4-6 Waypoint screen

8. Press the [ENT] key. Press ▲ or ▼ to select a waypoint.

9. Press the [ENT] key.

Note: If the name selected at step 9 has not been used, the window shown in Figure 4-7 appears. Select CREATE? or RENAME? as appropriate and press the [ENT] key.

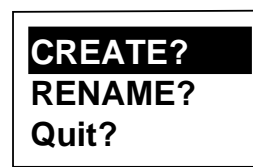

Figure 4-7 CREATE, RENAME prompt

10. Select Exit?.

11. Press the [ENT] key.

12. Press the [MENU] key twice to finish.

Permanently deleting a waypoint from a route

1. Press the [MENU] key twice.
2. Select ROUTES and press the [ENT] key.
3. Select the route from the ROUTES list.
4. Press the [ENT] key.
5. Select the waypoint you want to delete.
6. Press the [ENT] key.
7. Select REMOVE?.
8. Press the [ENT] key.
9. Select Exit? and press the [ENT] key.
10. Press the [MENU] key twice to finish.

Inserting a waypoint in a route

To insert a waypoint in a route, do the following:

1. Press the [MENU] key twice.
2. Select ROUTES and press the [ENT] key.
3. Select the route from the ROUTES list.
4. Press the [ENT] key.
5. Select the waypoint which will come after waypoint to be inserted. In Figure 4-8, for example, if you want to insert a waypoint between KOBE and 001, select 001.

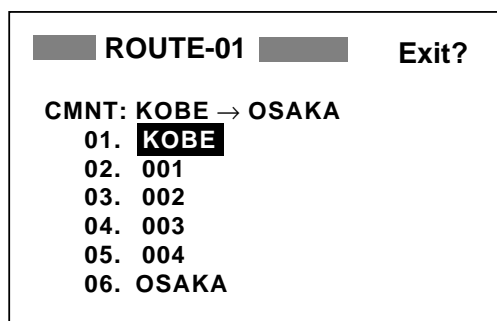

Figure 4-8 ROUTE screen

6. Press the [ENT] key.
7. Select INSERT?.
8. Press the [ENT] key.
9. Press ▲ or ▼ to select waypoint.
10. Press the [ENT] key.
11. Select Exit? and press the [ENT] key.
12. Press the [MENU] key twice to finish.

Temporarily deselecting a waypoint in a route

You can temporarily deselect an unnecessary waypoint from a route. Using the route created in Figure 4-9 as an example, deselect the 2nd intermediate waypoint.

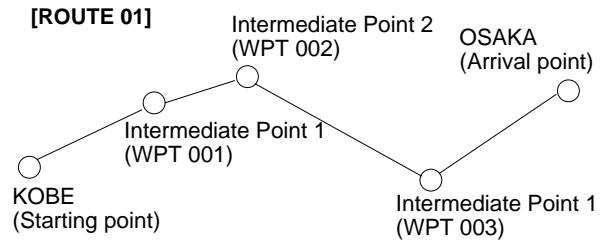

Figure 4-9 Sample route

If you reconstruct the route without the 2nd intermediate point it would look like Figure 4-10.

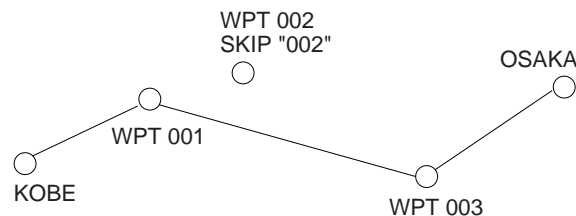

Figure 4-10 Route in Figure 4-9 reconstructed without 2nd intermediate waypoint

1. Press the [MENU] key twice.
2. Select ROUTES and press the [ENT] key.
3. Select a route from the ROUTES list, and press the [ENT] key.
4. Place the cursor on the waypoint to skip.
5. Press the [ENT] key.
6. Select SKIP? and press the [ENT] key. X appears to the left of the waypoint.

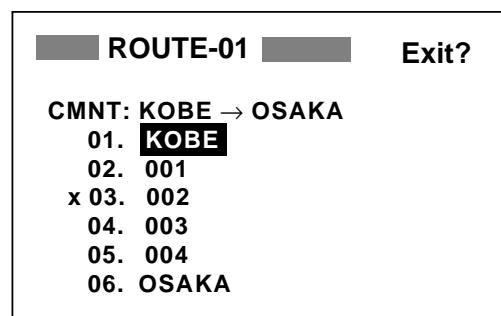

Figure 4-11 ROUTE screen

7. Select Exit? and press the [ENT] key.
8. Press the [MENU] key twice to finish.

To restore a waypoint to a route, select SKPoFF at step 6.

4.3 Deleting a Route

1. Press the [MENU] key twice.
2. Select ERASE and press the [ENT] key.
3. Select ROUTES? and press the [ENT] key.
4. Select the route you want delete. If you want to delete all routes, select ALL?.
5. Press the [ENT] key. You are asked if you are sure to delete the route.

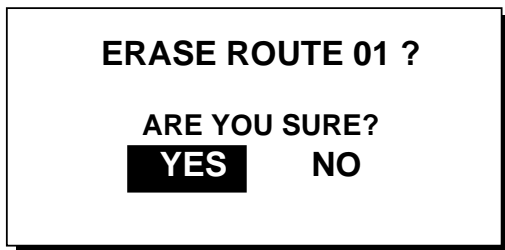

Figure 4-12 ERASE ROUTE prompt

6. Press the [ENT] key again.
7. Press the [MENU] key twice to finish.

5. SETTING, CANCELLING DESTINATION

Destination can be set four ways: by cursor, by waypoint, by route, and by MOB position. Destination cannot be set when there is no GPS position data. When there is no position data, the buzzer sounds and the message "GPS NO FIX" appears. Previous destination is cancelled whenever a destination is newly set.

- Place the cursor on the location desired for destination.
- Press the [ENT] key.

A dashed line connects own ship and the destination, which is marked with CURSOR and an X, as shown in Figure 5-3.

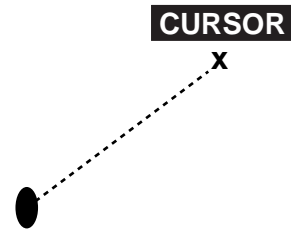

Figure 5-3 Destination set by cursor

5.1 Setting Destination by Cursor

- Press the [GOTO] key to display the GOTO window.

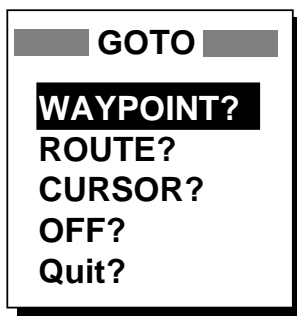

Figure 5-1 GOTO window

- Select CURSOR?.
- Press the [ENT] key.

Cursor appears with "?".

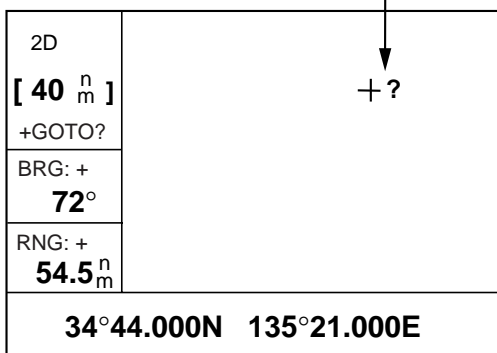

Figure 5-2 Cursor appearance when setting destination by cursor

5.2 Setting Destination by Waypoint

- Press the [GOTO] key.
- Select WAYPOINT?.
- Press the [ENT] key. The GOTO WYPT list appears.

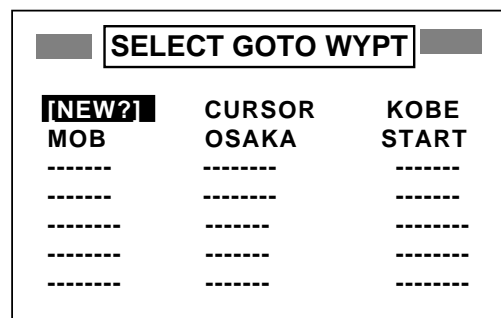

Figure 5-4 GOTO WYPT list

- Select a waypoint.
- Press the [ENT] key.

Own ship's position becomes starting point and a dotted line runs between it and the waypoint selected.

5.3 Setting Route as Destination

1. Press the [GOTO] key.
2. Select ROUTE?.
3. Press the [ENT] key.

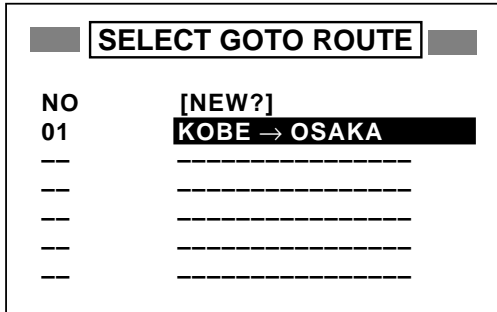

Figure 5-5 GOTO ROUTE list

4. Select a route.
5. Press the [ENT] key. The following window appears.



Figure 5-7 FORWARD, REVERSE prompt

6. Select FORWARD? or REVERSE?, the order in which to traverse the route waypoints, and press the [ENT] key.

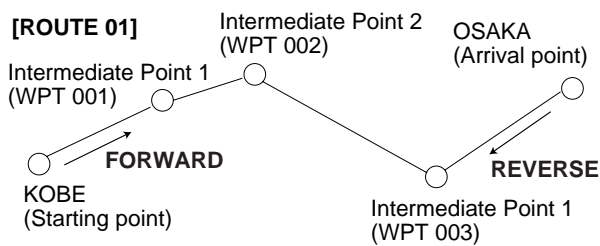

Figure 5-8 Meaning of forward and reverse

Current position becomes starting point. A dotted line runs between all route points.

5.4 Canceling Destination

You can cancel destination as follows:

1. Press the [GOTO] key.
2. Select OFF?.
3. Press the [ENT] key.

6. ALARMS

There are four alarm conditions which generate both audible and visual alarms: Arrival alarm, Anchor watch alarm, Speed alarm, and XTE (Cross Track Error) alarm.

When an alarm setting is violated, the buzzer sounds, and the name of the offending alarm and the alarm icon appear on the display. You can silence the buzzer and remove the alarm name indication by pressing any key but the alarm icon remains on the screen until the reason for the alarm is cleared.

You can also see which alarm(s) is sounding by displaying the MESSAGE board. The keying sequence is [MENU] (twice), select MESSAGES and press the [ENT] key. (The message board is explained in 8.2 Displaying the Message Board.)

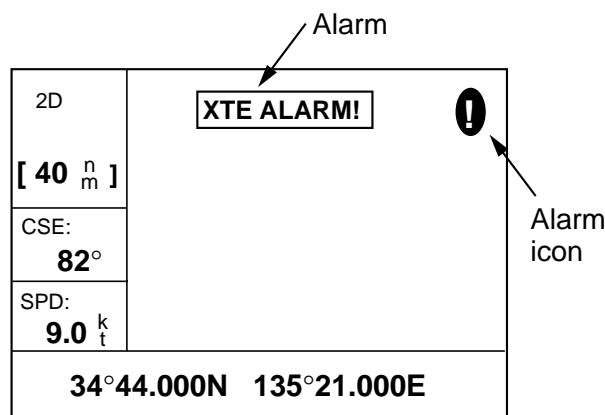

Figure 6-1 Location of alarm message and icon

6.1 Arrival Alarm, Anchor Watch Alarm

You may activate the arrival alarm or the anchor watch alarm; they cannot be activated together.

Arrival alarm

The arrival alarm informs you that own ship is approaching a destination waypoint. The area that defines an arrival zone is that of a circle which you approach from the outside of the circle. The alarm will be released if own ship goes out of the circle.

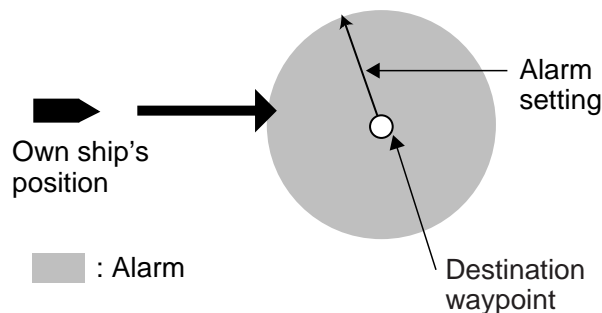

Figure 6-2 How the arrival alarm works

1. Press the [MENU] key twice.
2. Select ALARMS.
3. Press the [ENT] key. The ALARMS menu appears.

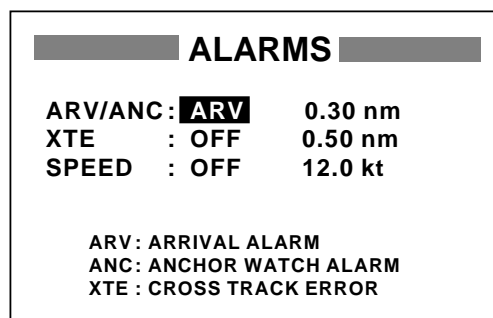

Figure 6-3 ALARMS menu

- The cursor is on the first line of the display. If ARV is already selected, press **▶** and [ENT], set the alarm range with the Cursor Pad and then go to step 6. If ARV is not selected, press the [ENT] key. The display shown in Figure 6-4 appears. Select ARV and press the [ENT] key.



Figure 6-4 Arrival/anchor window

- Press the [ENT] key. Enter the alarm range (0.01 – 99.99 nm) with the Cursor Pad.
- Press the [ENT] key.
- Press the [MENU] key twice to finish.

When own ship nears the GOTO waypoint by the range set here, the buzzer sounds and the message ARV ALARM! appears.

To disable the alarm, select OFF at step 4.

Anchor watch alarm

The anchor watch alarm sounds to warn you that own ship is moving when it should be at rest.

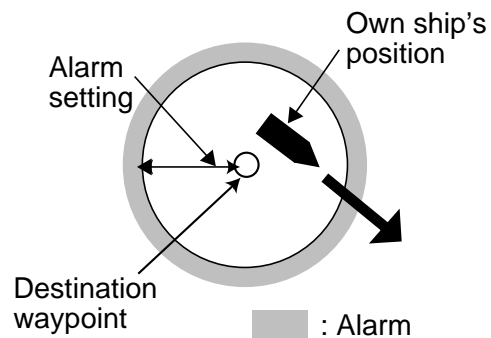

Figure 6-5 How the anchor watch alarm works

Before setting the anchor watch alarm, set present position as destination waypoint.

- Press the [MENU] key twice.
- Select ALARMS.
- Press the [ENT] key.
- If ANC is already selected, press **▶** and [ENT], set the alarm range with the Cursor Pad and then go to step 7. If ANC is not selected, press the [ENT] key. The display shown in Figure 6-4 appears. Select ANC and press the [ENT] key.
- Press the [ENT] key. Enter the alarm range (0.01 – 99.99 nm) with the Cursor Pad.
- Press the [ENT] key.
- Press the [MENU] key twice to finish.

When own ship drifts more than the range set here, the buzzer sounds and the message ANC ALARM! appears.

To disable the alarm, select OFF at step 4.

6.2 XTE (Cross Track Error) Alarm

The XTE alarm warns you when own ship is off its intended course.

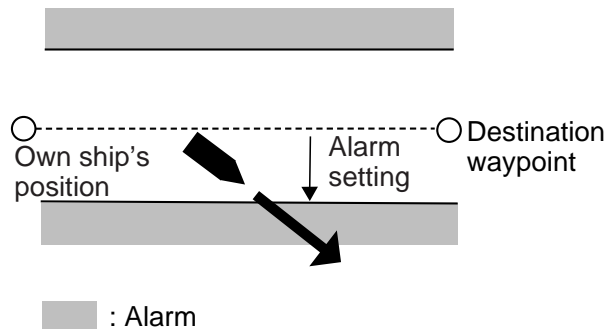

Figure 6-6 How the XTE alarm works

1. Press the [MENU] key twice.
2. Select ALARMS.
3. Press the [ENT] key.
4. Select the XTE line and press the [ENT] key.
5. Select ON and press the [ENT] key.
6. Press the [ENT] key.
7. Enter alarm range with the Cursor Pad.
8. Press the [ENT] key.
9. Press the [MENU] key twice to finish.

When own ship strays from the intended track by the range set here, the buzzer sounds and message XTE ERROR! appears.

To disable the alarm, select OFF at step 5.

6.3 Speed Alarm

The speed alarm sounds when ship's speed is higher (or lower) the alarm range set.

1. Press the [MENU] key twice.
2. Select ALARMS.
3. Press the [ENT] key.
4. Select the SPEED line and press the [ENT] key.
5. Select BELOW or OVER.

BELOW: Alarm sounds when speed is lower than speed set.

OVER: Alarm sounds when speed is higher than speed set.

6. Press the [ENT] key twice.
7. Enter speed with the Cursor Pad.
8. Press the [ENT] key.
9. Press the [MENU] key twice to finish.

When the speed alarm setting is violated, the buzzer sounds and the message SPD ALARM! appears.

To disable the alarm, select OFF at step 4.

7. OTHER FUNCTIONS

7.1 Calculating Range, Bearing and TTG

Range and bearing between two waypoints

1. Press the [MENU] key twice.
2. Select CALCULATE.
3. Press the [ENT] key.

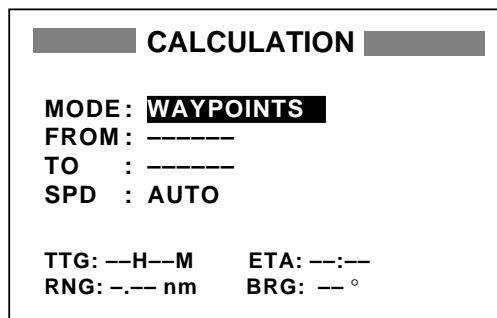

Figure 7-1 CALCULATION menu

4. Press the [ENT] key to display the window shown in Figure 7-2.



Figure 7-2 WAYPOINTS, ROUTE prompt

5. Select WAYPOINTS and press the [ENT] key.
6. Press the [ENT] key.
7. Enter the starting point and press the [ENT] key.
8. Press the [ENT] key, enter the end point and press the [ENT] key.
9. Press the [ENT] key. The window shown in Figure 7-3 appears.



Figure 7-3 AUTO, MANUAL prompt

10. Select AUTO or MANU. AUTO uses ship's average speed; MANU is for manual entry of speed.
11. Press the [ENT] key.
12. If you selected MANU, press the [ENT] key again. Enter speed with the Cursor Pad and press the [ENT] key.

Figure 7-4 shows what the display might look like using waypoints KOBE and OSAKA as the FROM and TO waypoints, respectively.

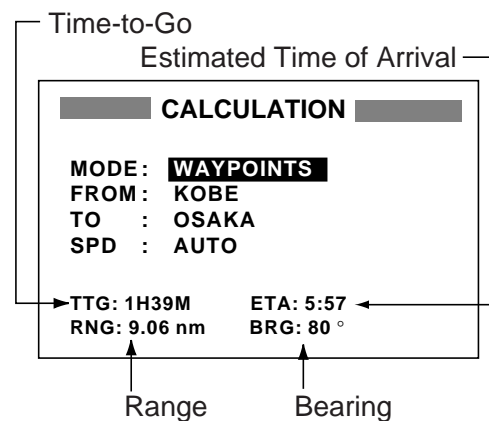

Figure 7-4 Typical calculation display

13. Press the [MENU] key twice to finish.

Range and bearing between first and final waypoints of a route

You can easily find the range, bearing TTG and ETA between the first point and final point of a route.

1. Press the [MENU] key twice.
2. Select CALCULATE and press the [ENT] key.
3. Press the [ENT] key.
4. Select ROUTE and press the [ENT] key.
5. Press the [ENT] key.
6. Select route number.
7. Press the [ENT] key to display the window shown in Figure 7-3.

8. Select **AUTO** or **MANU**. **AUTO** uses ship's average speed to calculate time-to-go; **MANU** is for manual entry of speed.
9. Press the **[ENT]** key. If you selected **AUTO** no further operation is necessary. For **MANU**, press the **[ENT]** key again. Enter speed with the Cursor Pad and press the **[ENT]** key.

Figure 7-5 shows what the display might look like using Route-01 for an example.

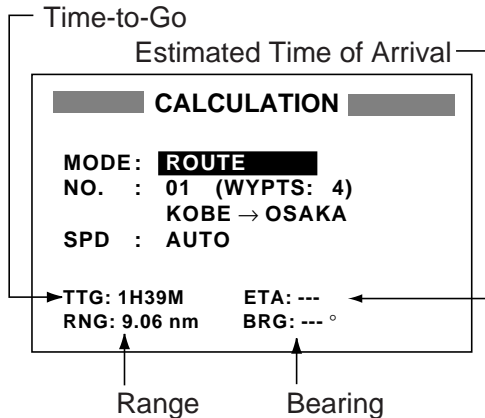

Figure 7-5 Typical calculation display (route)

7.2 DGPS Setup

The GP-35 is equipped with a DGPS beacon receiver, and the GP-30 may be connected to a DGPS beacon receiver. Set up to receive the DGPS beacon signal as follows:

1. Press the **[MENU]** key twice.
2. Select **D-GPS** and press the **[ENT]** key.

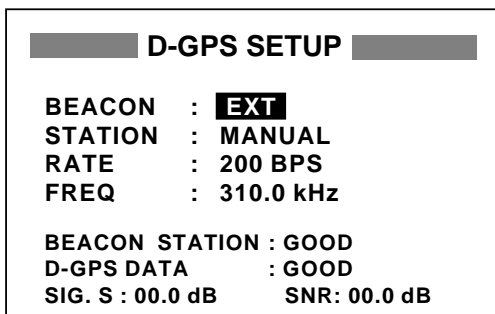

Figure 7-6 D-GPS SETUP menu

3. Press the **[ENT]** key.

4. Select **INT** for internal DGPS beacon receiver; **EXT** for external DGPS beacon receiver. Press the **[ENT]** key.
5. The cursor is on the **STATION** line. Press the **[ENT]** key.
6. Choose DGPS beacon station selection method: **AUTO 1**, **AUTO 2** or **MANUAL**.

AUTO 1, AUTO 2: Automatically search for nearest DGPS beacon station. The GP-35 always searches for nearest DGPS beacon station.

MANUAL: Manually enter DGPS beacon station specifications (on the **RATE** and **FREQ** lines), referring to the DGPS reference station list in the Appendix.

7. If you selected **AUTO**, no further operation is necessary; you may press the **[MENU]** key twice to finish. For **MANUAL**, the cursor is now on the **RATE** line. Press the **[ENT]** key.
8. Select the transmission rate of the DGPS beacon station nearest you, among 50, 100 or 200 bps. Press the **[ENT]** key.
9. The cursor is now on the **FREQ** line. Press the **[ENT]** key.
10. Enter nearest DGPS beacon station's frequency with the Cursor Pad.
11. Press the **[ENT]** key.
12. Press the **[MENU]** key twice to finish.

7.3 Bearing Reference

Ship's course and bearing to a waypoint may be displayed in true or magnetic bearing. Magnetic bearing is true bearing plus (or minus) earth's magnetic deviation.

The default setting displays magnetic bearings.

1. Press the **[MENU]** key twice.
2. Select **PLOTTER**.
3. Press the **[ENT]** key.

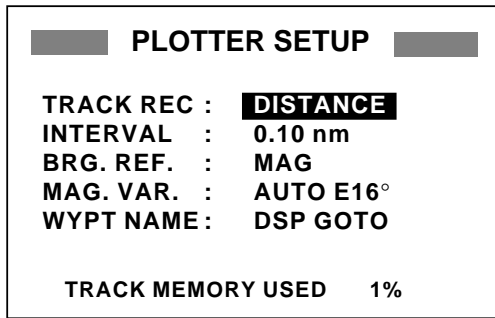

Figure 7-7 PLOTTER SETUP menu

4. Select the BRG. REF. line.
5. Press the [ENT] key. The following window appears.



Figure 7-8 Bearing reference window

6. Select MAG or TRUE.
7. Press the [ENT] key.
8. Press the [MENU] key twice to finish.

7.4 Magnetic Variation

The location of the magnetic north pole is different from the geographical north pole. This causes a difference between the true and magnetic north direction. This difference is called magnetic variation, and varies with respect to the observation point on earth. The GP-30/35 is preprogrammed with all the earth's magnetic variation. However, you may wish to enter variation manually to refine accuracy.

1. Press the [MENU] key twice.
2. Select PLOTTER and press the [ENT] key.
3. Select the MAG. VAR. line.
4. Press the [ENT] key.
5. Select AUTO or MANU and press the [ENT] key. For automatic magnetic variation, current variation appears to the right of AUTO.

6. If you selected AUTO, no further operation is necessary, press the [MENU] key twice to finish. For MANU, press the [ENT] key and enter magnetic variation as follows:
 - a) If necessary, change coordinate from east to west or vice versa by pressing ▲ or ▼.
 - b) Enter variation in two digits with the Cursor Pad, referring to a nautical chart.
 - c) Press the [ENT] key.
 - d) Press the [MENU] key twice to finish.

7.5 Geodetic Chart System

Select the geodetic chart system you are using as follows:

1. Press the [MENU] key twice.
2. Select SYS SETUP and press the [ENT] key.

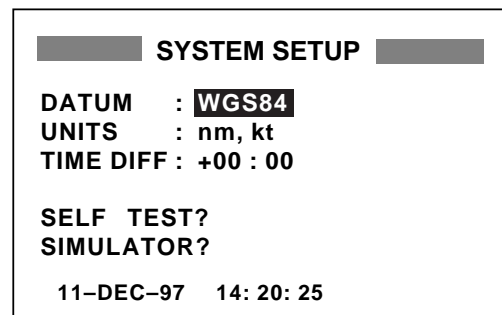

Figure 7-9 SYSTEM SETUP menu

3. Press the [ENT] key.
4. Select WGS84, WGS72 or OTHER and press the [ENT] key.
5. If you selected WGS72 or WGS84, press the [MENU] key twice to finish. For OTHER, do the following:
 - a) Press the [ENT] key.
 - b) Select chart number referring to the geodetic chart list on page A-4.
 - c) Press the [ENT] key.
 - d) Press the [MENU] key twice to finish.

7.6 Units of Measurement

Distance and speed can be displayed in the combinations of nautical miles/knots, kilometers/kilometers per hour, or miles/miles per hour.

1. Press the [MENU] key twice.
2. Select SYS SETUP and press the [ENT] key.
3. Press ▼.
4. Press the [ENT] key.
5. Choose combination desired; nm, kt; nm, km/h; mi, mi/h.
6. Press the [ENT] key.
7. Press the [MENU] key twice to finish.

7.7 Displaying Position in LOPs

Position may shown in LOPs (Loran C or Decca) as follows:

1. Press the [MENU] key twice.
2. Select LOP SETUP and press the [ENT] key.

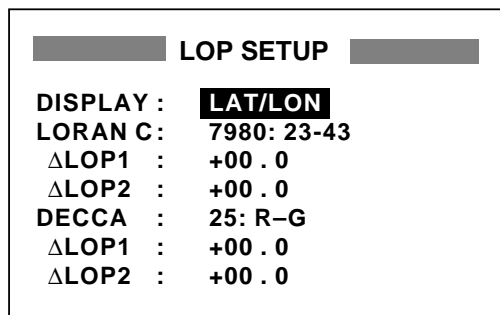

Figure 7-10 LOP SETUP menu

3. The cursor is on the first line. Press the [ENT] key. The following window appears.



Figure 7-11 LAT/LON, LC, DE window

4. Select LC LOP (Loran C) or DE LOP (Decca).

5. Press the [ENT] key.
6. Do one of the following:

For Loran C LOP;

- a) Press the [ENT] key and enter GRI code and secondary code with the Cursor Pad, referring to the Loran C chain list on the page A-10.
- b) Press the [ENT] key.

For Decca LOP;

- a) Select the DECCA line and press the [ENT] key.
 - b) Enter Decca chain number and lane pair (Red; R, Green; G and Purple; P) referring to the Decca chain list on the page A-11.
 - c) Press the [ENT] key.
7. Enter LOP offsets at appropriate Δ LOP1 and Δ LOP2 if necessary.
 8. Press the [MENU] key twice to finish.

7.8 Time Difference (using local time)

GPS uses UTC time. If you would rather use local time, enter the time difference (-13:00 to +13:00) between local time and UTC time.

1. Press the [MENU] key twice.
2. Select SYS SETUP and press the [ENT] key.
3. Press ▼ twice and press the [ENT] key.
4. Press ▲ or ▼ to display + or -.
5. Enter time difference with the Cursor Pad.
6. Press the [ENT] key.
7. Press the [MENU] key twice to finish.

7.9 GPS Setup

The GPS SETUP menu smooths position and course, averages speed, applies position offset, and deactivates unhealthy satellites.

1. Press the [MENU] key twice.
2. Select GPS SETUP and press the [ENT] key.

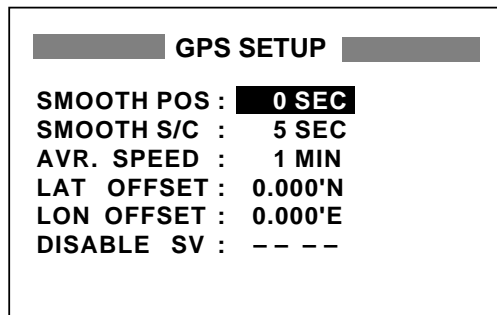

Figure 7-12 GPS SETUP menu

3. Select item and press the [ENT] key.
4. Change setting with the Cursor Pad and press the [ENT] key.
5. Press the [MENU] key twice to finish.

GPS SETUP menu description

SMOOTH POS (Smoothing position)

When the DOP or receiving condition is unfavorable, the GPS fix may change greatly, even if the vessel is dead in water. This change can be reduced by smoothing the raw GPS fixes. A setting between 0 and 999 is available. The higher the setting the more smoothed the raw data, however too high a setting slows response time to change in latitude and longitude. This is especially noticeable at high ship's speeds. "0" is the normal setting; increase the setting if the GPS fix changes greatly.

SMOOTH S/C (Smoothing speed/course)

During position fixing, ship's velocity (speed and course) is directly measured by receiving GPS satellite signals. The raw velocity data may change randomly depending on receiving conditions and other factors. You can reduce this random variation by increasing the smoothing. Like with latitude and longitude smoothing, the higher the speed and course smoothing the more smoothed the raw data. If the setting is too high, however, the response to speed and course change slows. For no smoothing, enter "0".

AVR. SPEED (Speed averaging)

Calculation of ETA and TTG, etc. is based on average ship's speed over a given period. If the period is too long or too short calculation error will result. Change this setting if calculation error occurs. The default setting is one minute.

LAT/LON OFFSET (Position offset)

You may apply an offset to position generated by the GPS receiver, to increase position accuracy.

DISABLE SV (Disable satellite)

Every GPS satellite is broadcasting abnormal satellite number(s) in its Almanac, which contains general orbital data about all GPS satellites. Using this information, the GPS receiver automatically eliminates any malfunctioning satellite from the GPS satellite schedule. However, the Almanac sometimes may not contain this information. You can disable an inoperative satellite manually. Enter satellite number in two digits and press the [ENT] key. To restore a satellite enter "0".

7.10 Uploading, Downloading Waypoint, Route Data

Waypoint and route data may be downloaded to a PC or upload from a PC to the GP-30/35.

Wiring

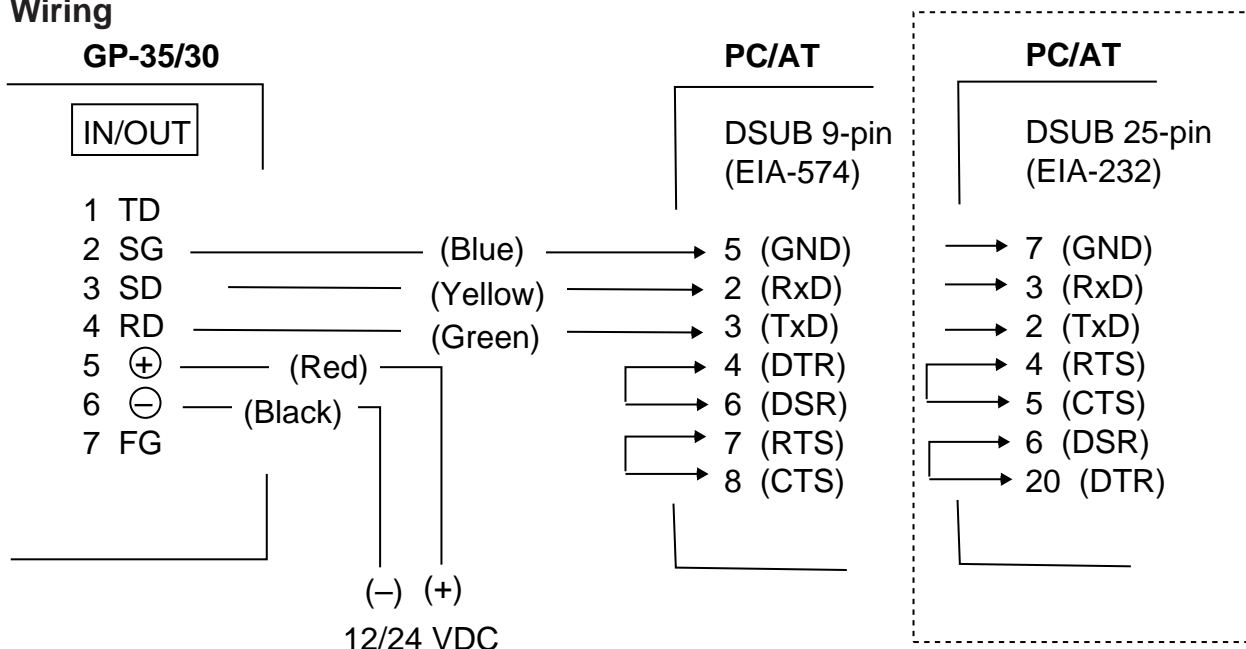

Figure 7-13 Connection of GP-35 to PC

Setting for communication software on PC

Baud Rate: 4800 bps
 Character Length: 8 bit
 Stop Bit: 1 bit
 Parity: None
 X Control: XON/XOFF

Downloading/Uploading between PC and GP-30/35

The following data can be downloaded/uploaded between a personal computer and GP-30/35.

- Waypoint data (In alphanumerical order)
- Route data (In order of route number)
- End of sentence

Note 1: There are two kinds of data for route data: route data and route comment data.

Note 2: Data cannot be uploaded or downloaded when a DGPS beacon receiver is active. To receive or transmit data, set BEACON on the D-GPS SETUP menu to OFF.

Note 3: DPGS position fix is not available when uploading or downloading data.

Downloading to PC

1. Open the I/O SETUP menu.
2. Select SAVE WP/RTE → PC?.

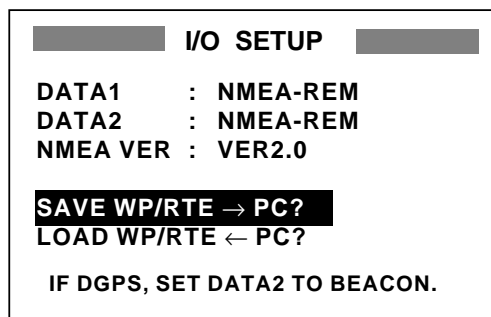

Figure 7-14 I/O SETUP menu

3. Press the [ENT] key.

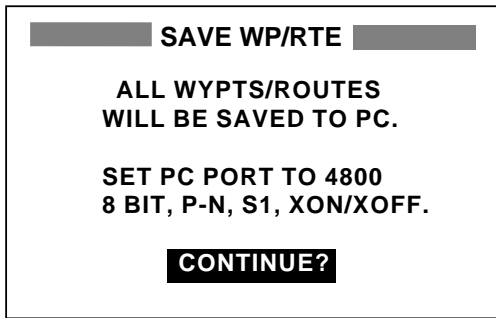

Figure 7-15 SAVE WP/RTE display

4. Press the [ENT] key.

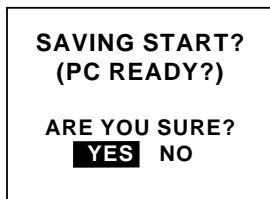

Figure 7-16 SAVING START? prompt

5. Operate the computer to receive data there.
6. Press the [ENT] key.

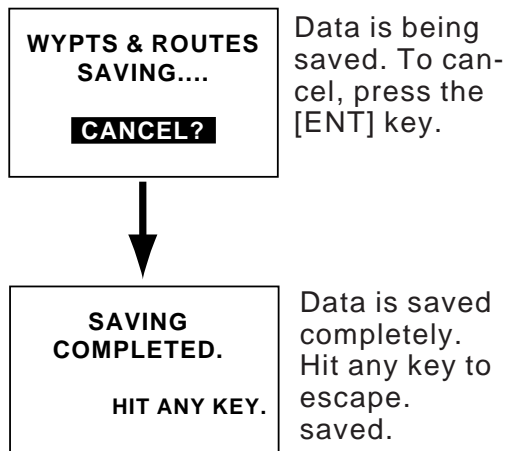

Figure 7-17 Displays when downloading data

7. Press any key to escape.

Uploading from PC

Note that all waypoint and route data stored in GP-30/35 will be deleted when data is uploaded.

1. Open the I/O SETUP menu.
2. Select LOAD WP/RTE ← PC?.

3. Press the [ENT] key.

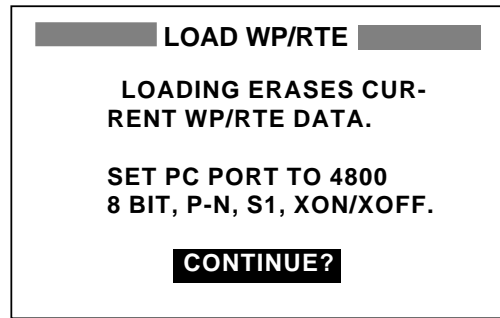

Figure 7-18 LOAD WP/RTE display

4. Press the [ENT] key.

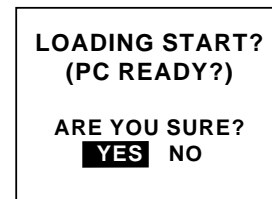

Figure 7-19 LOADING START? prompt

5. Press the [ENT] key.

Note: The waypoint and route data are deleted when the [ENT] key is pressed.

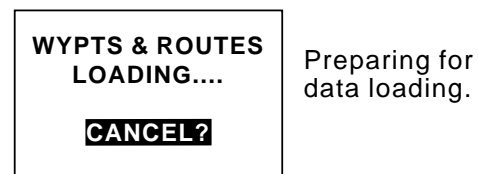

Figure 7-20 Display when data is being loaded

6. Operate the computer to output data from the computer
7. When data loading is finished, the following message appears.



Figure 7-21 Display when data is loaded successfully

8. Press any key to escape.

Waypoint data format

PFEC,	GPwpl,	llll.lll,	a,	yyyyy.yyy,	a,	c----c,	c,	c----c,	a,	hhmmss,	xx,	xx,	xxxx	<CR><LF>
			1	2	3	4	5	6	7	8	9	10	11	12

Figure 7-22 Waypoint data format

- 1: Waypoint latitude
- 2: N/S
- 3: Waypoint longitude
- 4: E/W
- 5: Waypoint name (Number of characters is fixed to 6 and space code is placed when the number of characters are less than 6.)
- 6: Waypoint color (This field is always kept NULL.)
- 7: Waypoint comment (2 byte for mark code + 16 characters of comment.)
 - 1st byte of mark code: Fixed to '@'.
 - 2nd byte of mark code: Internal mark code + 'a' (0 x 61). See Note 1.
 - Number of characters for comment is less than 16 (variable length). See Note 2.
- 8: Flag making waypoint. Always set to "A".
 - "A": Displayed
 - "V": Not displayed
- 9: UTC (Always NULL)
- 10: Day (Always NULL)
- 11: Month (Always NULL)
- 12: Year (Always NULL)

Note 1: Internal mark code is 0 x 10 through 0 x 18. 0 x 71 through 0 x 79 are always placed at 2nd byte of mark code.

Note 2: Following characters can be used for comments:

_ABCDEFGHIJKLMNOPQRSTUVWXYZ0123456789&()+-/?}												
0x10: □ (q)	0x11: ✕ (r)	0x12: ↘ (s)	0x13: ⌈ (t)	0x14: ■ (u)								
0x15: + (v)	0x16: H (w)	0x17: ■ (x)	0x18: ⊕ (y)									

Figure 7-23 Characters available for comments

Route data format

\$GPRTE, <u>x</u> , <u>x</u> , <u>a</u> , <u>cc</u> , <u>c----c</u> , <u>c----c</u> , ... , <u>c----c</u> <CR><LF>
1 2 3 4 5 6 12

Figure 7-24 Route data format

- 1:** Number of sentences required for one complete route data (1 to 4). See Note.
- 2:** Number of sentences currently used (1 to 4)
- 3:** Message mode (Always set to C).
- 4:** Route No. (01 to 30, 2 digits required)
- 5 through 12:** Waypoint name (Max. 8 names, length of each waypoint name is fixed to 7 byte)

1st byte: Skip code '-' (Hyphen) = Skip ON, Space code = Skip OFF

After 2nd byte: Waypoint name (fixed to 6 bytes)

Note: A route can contain max. 30 waypoints and GPRTE sentence for one route data may exceed 80 byte limitation. In this case, route data is divided into several GPRTE sentences (Max. 4 sentences). This value shows the number of sentences route data has been divided.

Route comment data format

\$PFEC, GPrtc, <u>xx</u> , <u>c----c</u> <CR><LF>
1 2

Figure 7-25 Route comment data format

- 1:** Route No. (01 to 30, 2 digits required)
- 2:** Route comment (Max. 16 characters, variable length)

The same characters of the comment for waypoint comment can be used.

End of sentence

\$PFEC, GPxfr, CTL, E <CR><LF>

Figure 7-26 End of sentence

8. MAINTENANCE & TROUBLESHOOTING

8.1 Maintenance

Check the following points regularly to maintain performance:

- Check that connectors on the rear panel are firmly tightened and free of rust.
- Check that the ground system is free of rust and the ground wire is tightly fastened.
- Check that battery terminals are clean and free of rust.
- Check the antenna for damage. Replace if damaged.
- Dust and dirt on the keyboard and display screen may be removed with a soft cloth. Do not use chemical cleaners to clean the equipment; they may remove paint and markings.

8.2 Displaying the Message Board

The message board displays error messages and alerts. You can display it as follows:

1. Press the [MENU] key twice.
2. Select MESSAGES.
3. Press the [ENT] key.

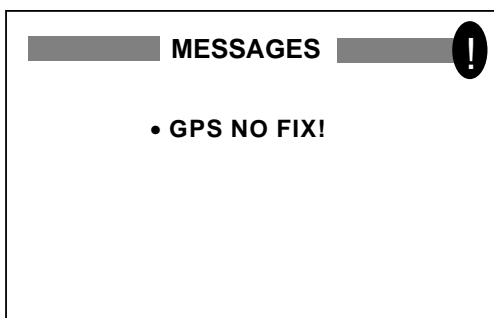

Figure 8-1 MESSAGE board

4. Press the [MENU] key twice to quit the message board.

Messages

Table 8-1 Messages and their meanings

Message	Meaning, Remedy
ANCHOR WATCH ALARM!	Anchor watch alarm setting violated.
ARRIVAL ALARM!	Arrival alarm setting violated.
BACKUP DATA ERROR!	RAM data corrupted. Try to clear backup data. See page 8-3.
BATTERY ALARM!	Voltage of internal battery is low. Request replacement.
DGPS ERR!	No DGPS signal. Check antenna.
NO FIX!	No GPS signal. Check antenna cable.
RAM ERROR!	Request service.
ROM ERROR!	Request service.
RTC ERROR!	Request service.
SPEED ALARM!	Speed alarm setting violated.
XTE ALARM!	XTE alarm setting violated.

8.3 Displaying the GPS Satellite Monitor Display

The GPS satellite monitor display shows information about GPS satellites.

1. Press the [MENU] key twice.
2. Select SATELLITE.
3. Press the [ENT] key.

Number, bearing and elevation angle of all satellites in view of the GPS receiver appear. Satellites being used in fixing position are displayed in reverse video; satellites not being used are shown in normal video.

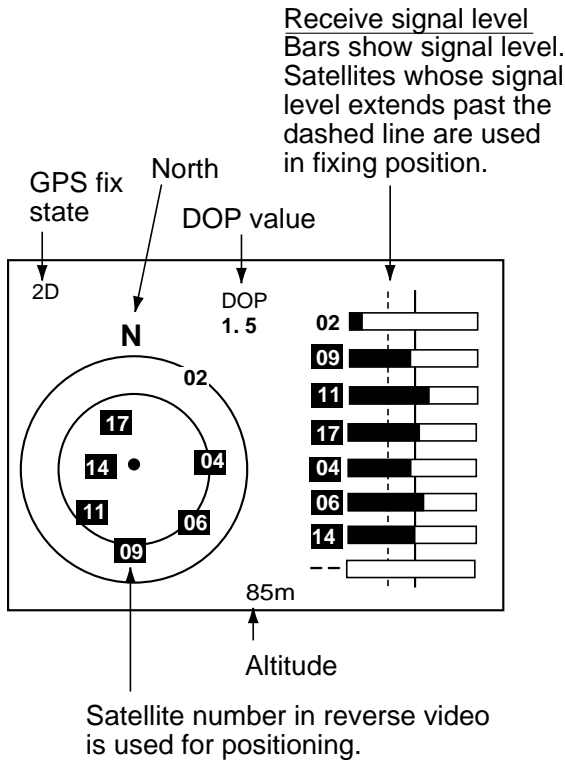

Figure 8-2 GPS satellite monitor display

4. Press the [MENU] key twice to quit the SATELLITE display.

8.4 Self Test

The self test checks ROM, RAM, data port, beacon receiver, battery, RTC, keyboard and LCD for proper operation.

1. Press the [MENU] key twice.
2. Select SYS SETUP and press the [ENT] key.
3. Select SELF TEST? and press the [ENT] key.

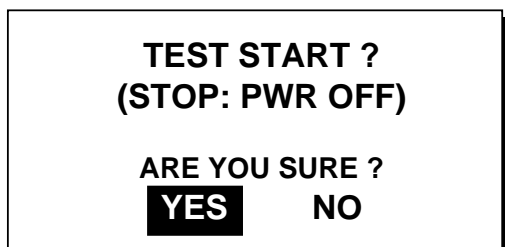

Figure 8-3 TEST START screen

4. Press the [ENT] key to start the test.

5. The equipment tests devices, data port, beacon receiver, battery and RTC. The results are individually displayed as OK or NG (No Good). (NONE appears next to BEACON when no beacon receiver is connected.)

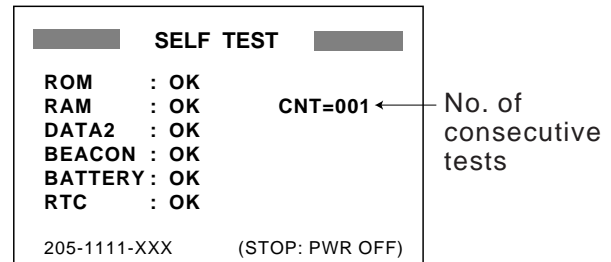

Figure 8-4 SELF TEST display

6. After the equipment has checked the items mentioned in step 5, a beep sounds and the message PUSH KEY appears.
 7. Press each key one by one. The name of the key pressed momentarily appears at the lower right-hand corner if the key is functioning properly.
- Note:** If no key is pressed within several seconds, the equipment automatically proceeds to step 8.
8. The equipment displays the following message to inform you that it is now going to check the LCD:

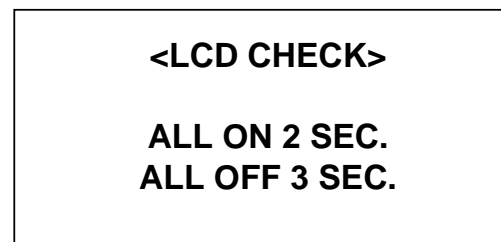

Figure 8-5 LCD CHECK screen

9. The test repeats after the LCD is checked. To stop the test, turn off the power.

8.5 When “BATTERY ALARM!” Appears

A lithium battery (type: TZ6580553A, code no.: 000-139-051) is installed on the circuit board inside the display unit and it preserves data when the power is turned off. The life of the battery is about three years. When the battery voltage is low “BATTERY ALARM!” appears on the display to alert you. When this happens, contact your dealer to request replacement of the battery.

8.6 Clearing Data

You may clear GPS data and menu settings individually or collectively, to start afresh with default settings or, in some cases, restore normal operation. If you require previous menu settings jot them down before clearing data. To fix position again, when GPS data is cleared, reset the power.

GPS data

1. Press the [MENU] key twice.
2. Select ERASE and press the [ENT] key.
3. Select GPS DATA? and press the [ENT] key. The following message appears.

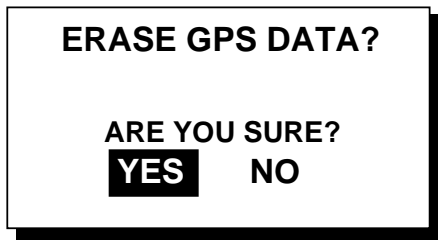

Figure 8-6 Prompt for erasure of GPS data

4. Press the [ENT] key.



Figure 8-7 Prompt for restarting

5. Press any key. The buzzer sounds while GPS data is being cleared.

Clearing menu settings

All default menu settings are restored when menu settings are cleared. Note that waypoints and routes are not cleared.

1. Press the [MENU] key twice.
2. Select ERASE and press the [ENT] key.
3. Select MENU SETTINGS? and press the [ENT] key. The following message appears.

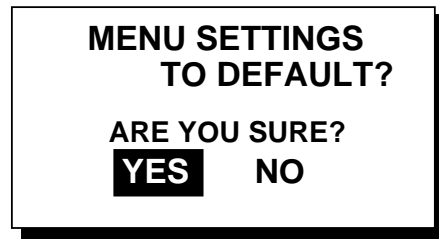

Figure 8-8 Prompt for erasure of menu settings

4. Press the [ENT] key.



Figure 8-9 Prompt for restarting

5. Press any key. The buzzer sounds while menu settings are being cleared.

Clearing all backup data

When the equipment detects backup data error it displays the message **BACKUP DATA ERROR!**. In this case it may be necessary to clear all backup data (GPS data, menu settings including waypoints and routes) to restore normal operation. When backup data is cleared all default menu settings are restored.

1. Press the [MENU] key twice.
2. Select **ERASE** and press the [ENT] key.
3. Select **ALL BACKUP DATA?** and press the [ENT] key. The following message appears.

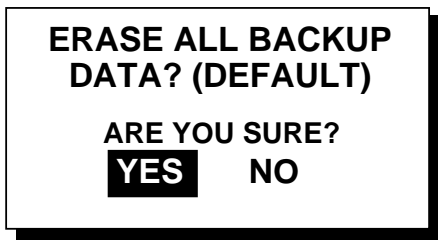

Figure 8-10 Prompt for erasure of all backup data

4. Press the [ENT] key.



Figure 8-11 Prompt for restarting

5. Press any key. The buzzer sounds while backup data is being cleared.

9. INSTALLATION

9.1 Installation of Display Unit

Mounting considerations

The display unit can be installed on a tabletop, on the overhead, or in a panel (optional flush mounting kit required). Refer to the outline drawing on page D-2, D-3 or D-4 for installation instructions. When selecting a mounting location, keep in mind the following points:

- Locate the unit away from exhaust pipes and vents.
- The mounting location should be well ventilated.
- Mount the unit where shock and vibration are minimal.
- Locate the display unit away from equipment which generates electromagnetic fields such as a motor or generator.
- Allow sufficient maintenance space at the sides and rear of the unit and leave sufficient slack in cables, to facilitate maintenance and servicing.

Tabletop and overhead mounting

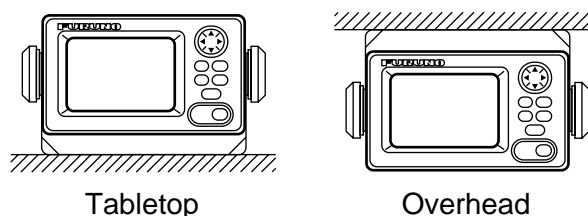

Figure 9-1 Tabletop and overhead mounting methods

Flush mounting

There are two types of flush mounting kits. For details, see the outline drawing on page D-3 and D-4.

9.2 Installation of Antenna Unit

Mounting considerations

Install the antenna unit referring to the installation diagram on page D-1. When selecting a mounting location for the antenna unit, keep in mind the following points:

- Select a location out of the radar beam. The radar beam will obstruct or prevent reception of the GPS satellite signal.
- The location should be well away from a VHF antenna. A GPS receiver is interfered by a harmonic wave of a VHF antenna.
- There should be no interfering object within the line-of-sight to the satellites. Objects within line-of-sight to a satellite, for example, a mast, may block reception or prolong acquisition time.
- Mount the antenna unit as high as possible. Mounting the antenna unit as high as possible keeps it free of interfering objects and water spray, which can interrupt reception of GPS satellite signal if the water freezes.
- The length of the whip antenna for the GP-35 should be no longer than 1.2 meter to prevent antenna damage. **Do not use a 2.5 meter whip antenna.**
- Do not shorten the antenna cable.
- If the antenna cable is to be passed through a hole which is not large enough to pass the connector, you may unfasten the connector with a needle nose pliers and 3/8-inch open-end wrench. Refasten it as shown in Figure 9-2 after running the cable through the hole.

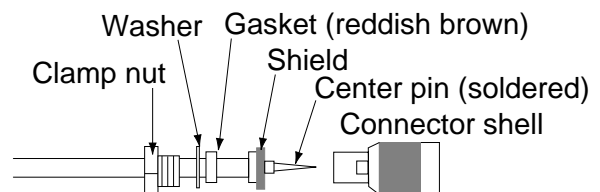

Figure 9-2 How to assemble the connector

9.3 Wiring

The figure below shows where to connect cables on the rear of the display unit.

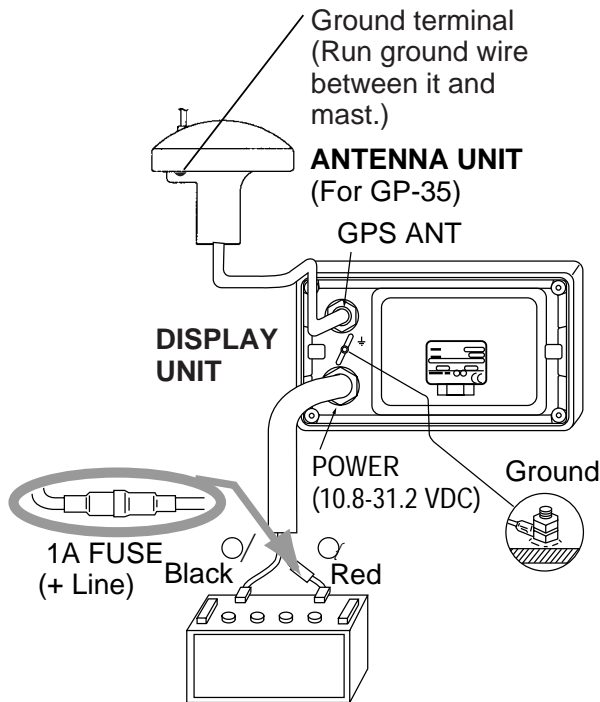

Figure 9-3 Wiring

Note: The fuse holder contains a spring which fixes the fuse. To fix the spring, tie the line as shown in Figure 9-4.

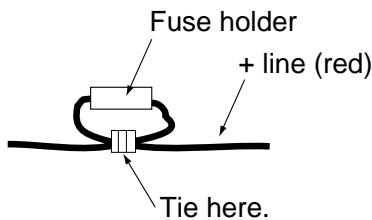

Figure 9-4 How to fix spring in fuse holder

Grounding

The display unit contains a CPU. While it is operating, it radiates noise, which can interfere with radio equipment. Ground the unit as follows to prevent interference:

- The ground wire should be 1.25sq or larger.
- The ground wire should be as short as possible.
- The signal ground and frame ground are separated, however the power line is not isolated. Therefore, do not connect the signal ground to the frame ground when connecting other equipment to a positive ground battery.
- The antenna unit GPA-018 must be grounded. Connect a ground wire of 1.25sq or larger (local supply) between the ground terminal on the antenna unit and a stainless steel screw fastened to the mast. Coat the ground terminal, stainless steel screw and crimp-on lugs on the ground wire with silicone sealant.
- The power of the GP-35 is not isolated, thus the earth lamp may light when the antenna unit is grounded. If it lights, attach two capacitors (1 μ F, 0.1 μ F) in parallel to the antenna earth line.

External equipment

The power supply port is commonly used for connection of external equipment such as navigation equipment or a PC. Refer to the interconnection diagram on page S-1 for connection.

9.4 Initial Settings

The GP-35 can output navigation information to external equipment, in NMEA 0183 format. For example, it can output position data to a radar or echo sounder for display on its display screen.

Output data format, data sentences

NMEA 0183 version 1.5 or 2.0 can be selected through the menu.

Menu Item	Output data sentences
NMEA-REM	BWC, GGA, GLL, RMC, RMB, VTG, ZDA
NMEA-AP	GLL, APB, BOD, XTE, AAM, VTG

AAM:Arrival alarm

APB: Autopilot data (XTE and bearing to waypoint)

BOD: Bearing from own ship to destination

BWC:Range and bearing to waypoint (great circle navigation)

GGA: GPS position fixing condition (time of fix, latitude, longitude, receiving condition, number of satellites used, DOP)

GLL: Latitude and longitude

RMB: Generic navigational information (cross track error, steering direction, starting waypoint no., destination waypoint no., latitude and longitude of starting waypoint, latitude and longitude of destination waypoint, range and bearing to waypoint, range and bearing from present position to destination waypoint, velocity to destination, arrival alarm)

RMC: Generic navigational information (UTC time, latitude, longitude, ground speed, true course, day, month, year)

VTG: Actual track and ground speeds

XTE: Course error amount and direction to steer

ZDA: UTC time (minutes, seconds, date, time difference)

Output setting

1. Press [MENU] twice to display the MAIN MENU.
2. Operate the Cursor Pad to select I/O SETUP.
3. Press the [ENT] key.

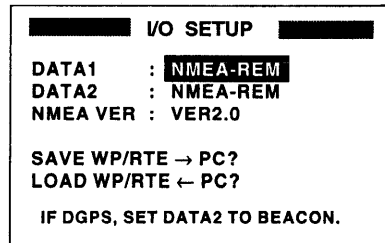

Figure 9-5 I/O SETUP menu

4. To change setting, press ▼ to select DATA1, DATA2 or NMEA VER.
5. Press the [ENT] key. One of the following screens appears depending on the item selected at step 4.

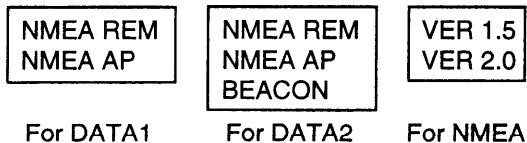

Figure 9-6 Screens for output and NMEA version setup

6. Select desired option with ▼.
7. Press the [ENT] key.
8. Repeat steps 4 to 7 to set other items.
9. Press the [MENU] key to finish.

Note: The GP-30/35 cannot receive or transmit data when a DGPS beacon receiver is active. To receive or transmit data, set BEACON on the D-GPS SETUP menu to OFF.

SPECIFICATIONS

The GP-30 and GP-35 are essentially the same except the GP-35 has an internal DGPS beacon receiver.

1. GPS Receiver

Receiving Channels	8 channels, 8 satellite tracking, Parallel tracking
Rx Frequency	1575.42 MHz
Rx Code	C/A code
Position Fixing System	All in view, 8-state Kalman filter
Position accuracy	Approx. 50 m (GPS) or 5 m (DGPS), 95% of the time, horizontal dilution of position (HDOP) ≤ 4 <i>Note: All GPS receivers are subject to degradation of position and velocity accuracy under the U.S. Department of Defense.</i>
Tracking Velocity	900 kts
Position-fixing Time	Warm start: 20 seconds, Cold start: 2 minutes
Beacon Receiver of GP-35	Frequency range: 283.5 to 325.0 kHz MSK rate: 25, 50, 100, 200 bps (auto or manual, selectable)

2. Display Section

LCD	95 x 60 mm (120 x 64 dot matrix)
Display Mode	Plotter, Highway, Steering, Nav Data Display
Display	Mercator projection Position indication Latitude/longitude or LOPs
Storage Capacity	Track: 1,000 pts Waypoint: 350 pts with comment (16 characters) Route: 30 routes with 30 waypoints each
Alarms	Arrival, Anchor watch, Cross track error, Speed
Display Scale	Plotter Display: 0.2, 0.5, 1, 2, 5, 10, 20, 40, 80, 160, 320 nm Highway Display: 0.2, 0.4, 0.8, 1, 2, 4, 8, 16 nm

3. Data Input/Data Output

Number of Ports	Output: 2 ports, Input: 1 Port
Input Data	DGPS: RTCM SC104 Ver. 2.1 TYPE 1, 9 (For uploading from PC or downloading to PC)
Output Data	NMEA0183: Ver. 1.5 or Ver. 2.0 For Remote: BWC, GGA, GLL, RMC, RMB, VTG, ZDA For Autopilot: GLL, APB, BOD, XTE, AAM, VTG

4. Power Supply & Power Consumption

Power Supply	10.8 to 31.2 VDC
Power Consumption	less than 3 W

5. Environmental Conditions

Useable Temperature	Antenna unit: -25°C to +70°C Display unit: -15°C to +55°C
Humidity	95% (40°C)
Waterproofing	Antenna unit: IEC 529 1PX6 Receiver unit: IEC 529 1PX5(USCG CFR-46)

EQUIPMENT LISTS

Standard Supply

Name	Type	Qty	Remarks	
Display Unit	GP-35	1	BEACON board incorporated	Including hanger and knob bolts
	GP-30	1	No BEACON board	
Antenna Unit	GPA-018	1	For GP-35, GPS/DGPS beacon antenna w/10 m cable	
	GPA-017	1	For GP-30, with 10 m cable	
Installation Materials		1 set	<ul style="list-style-type: none"> • Power cable • Tapping screw (4 pcs.) • Spring washer 	
Spare Parts		1 set	Fuse (2 pcs.)	

Optional Equipment

Name	Type	Code No.	Remarks
Flush Mount Kit S	OP20-17	000-040-720	For display unit
Flush Mount Kit F	OP20-29	000-041-405	
Right Angle Antenna Base	No.13-QA330	000-803-239	For antenna unit
L-type Antenna Base	No.13-QA310	000-803-240	
Handrail Antenna Base	No.13-RC5160	000-807-114	
Mast Mount Kit	CP20-01111	004-365-780	
GP-30 Modification Kit			
Rectifier	PR-62	000-013-485	For 110 VAC mains
		000-013-486	For 220 VAC mains

GEODETIC CHART LIST

001: WGS84		087: MAPARIMA, BWI	: Trinidad & Tobago
002: WGS72		088: NORTH AMERICAN 1927	: Western United States
003: TOKYO	: Mean Value (Japan, Korea & Okinawa)	089:	: Eastern United States
004: NORTH AMERICAN 1927	: Mean Value (CONUS)	090:	: Alaska
005: EUROPEAN 1950	: Mean Value	091:	: Bahamas (excl. San Salvador Is.)
006: AUSTRALIAN GEODETIC 1984	: Australia & Tasmania	092:	: Bahamas, San Salvador Is.
007: ADINDAN	: Mean Value (Ethiopia & Sudan)	093:	: Canada (incl. Newfoundland Is.)
008:	: Ethiopia	094:	: Alberta & British Columbia
009:	: Mali	095:	: East Canada
010:	: Senegal	096:	: Manitoba & Ontario
011:	: Sudan	097:	: Northwest Territories & Saskatchewan
012: AFG	: Somalia	098:	: Yukon
013: AIN EL ABD 1970	: Bahrain Is.	099:	: Canal Zone
014: ANNA 1 ASTRO 1965	: Cocos Is.	100:	: Caribbean
015: ARC 1950	: Mean Value	101:	: Central America
016:	: Botswana	102:	: Cuba
017:	: Lesotho	103:	: Greenland
018:	: Malawi	104:	: Mexico
019:	: Swaziland	105: NORTH AMERICAN 1983	: Alaska
020:	: Zaire	106:	: Canada
021:	: Zambia	107:	: CONUS
022:	: Zimbabwe	108:	: Mexico, Central America
023: ARC 1960	: Mean Value (Kenya & Tanzania)	109: OBSERVATORIO 1966	: Corvo & Flores Islands (Azores)
024:	: Kenya	110: OLD EGYPTIAN 1930	: Egypt
025:	: Tanzania	111: OLD HAWAIIAN	: Mean Value
026: ASCENSION IS. 1958	: Ascension Is.	112:	: Hawaii
027: ASTRO BEACON "E"	: Iwo Jima Is.	113:	: Kauai
028: ASTRO B4 SOR. ATOLL	: Tern Is.	114:	: Maui
029: ASTRO POS 71/4	: St. Helena Is.	115:	: Oahu
030: ASTRONOMIC STATION 1952	: Marcus Is.	116: OMAN	: Oman
031: AUSTRALIAN GEODETIC 1966	: Australia & Tasmania	117: ORDNANCE SURVEY OF GREAT BRITAIN 1936: Mean Value	: England
032: BELLEVUE (IGN)	: Efate & Erromango Islands	118:	: England
033: BERMUDA 1957	: Bermuda Islands	119:	: England, Isle of Man & Wales
034: BOGOTA OBSERVATORY	: Columbia	120:	: Scotland, & Shetland Islands
035: GAUPO INCHAUSPE	: Argentina	121:	: Wales
036: CANTON IS. 1966	: Phoenix Islands	122: PICO DE LAS NIVIES	: Canary Islands
037: CAPE	: South Africa	123: PITCAIRN ASTRO 1967	: Pitcairn Is.
038: CAPE CANAVERAL	: Mean Value (Florida & Bahama Islands)	124: PROVISIONS SOUTH CHILEAN 1963: South Chile (near 53° S)	: South Chile (near 53° S)
039: CARTHAGE	: Tunisia	125: PROVISIONAL SOUTH AMERICAN 1956: Mean Value	: Bolivia
040: CHATHAM 1971	: Chatham Is. (New Zealand)	126:	: Chile-Northern Chile (near 19° S)
041: CHUA ASTRO	: Paraguay	127:	: Chile-Southern Chile (near 43° S)
042: CORREGO ALEGRE	: Brazil	128:	: Columbia
043: DJAKARTA (BATAVIA)	: Sumatra Is. (Indonesia)	129:	: Ecuador
044: DOS 1968	: Gizo Is. (New Georgia Is.)	130:	: Ecuador
045: EASTER IS. 1967	: Easter Is.	131:	: Guyana
046: EUROPEAN 1950 (Cont'd)	: Western Europe	132:	: Peru
047:	: Cyprus	133:	: Venezuela
048:	: Egypt	134: PUERTO RICO	: Puerto Rico & Virgin Islands
049:	: England, Scotland, Channel & Shetland Islands	135: QATAR NATIONAL	: Qatar
050:	: England, Ireland, Scotland, & Shetland Islands	136: QORNOQ	: South Greenland
051:	: Greece	137: ROME 1940	: Sardinia Islands
052:	: Iran	138: SANTA BRAZ	: Sao Maguel, Santa Maria Islands (Azores)
053:	: Italy, Sardinia	139: SANTO (DOS)	: Espirito Santo Is.
054:	: Italy, Sicily	140: SAPPER HILL 1943	: East Falkland Is.
055:	: Norway & Finland	141: SOUTH AMERICAN 1969	: Mean Value
056:	: Portugal & Spain	142:	: Argentina
057: EUROPEAN 1979	: Mean Value	143:	: Bolivia
058: GANDAJIKA BASE	: Republic of Maldives	144:	: Brazil
059: GEODETIC DATUM 1949	: New Zealand	145:	: Chile
060: GUAM 1963	: Guam Is.	146:	: Columbia
061: GUX 1 ASTRO	: Guadalcanal Is.	147:	: Ecuador
062: HJORSEY 1955	: Iceland	148:	: Guyana
063: HONG KONG 1363	: Hong Kong	149:	: Paraguay
064: INDIAN	: Thailand & Vietnam	150:	: Peru
065:	: Bangladesh, India & Nepal	151:	: Trinidad & Tobago
066: IRELAND 1965	: Ireland	152:	: Venezuela
067: ISTS 073 ASTRO 1969	: Diego Garcia	153: SOUTH ASIA	: Singapore
068: JOHNSTON IS. 1961	: Johnston Is.	154: SOUTHEAST BASE	: Porto Santo & Madeira Islands
069: KANDAWALA	: Sri Lanka	155: SOUTHWEST BASE	: Faial, Graciosa, Pico, Sao Jorge, & Terceira Is.
070: KERGUELEN IS.	: Kerguelen Is.	156: TIMBALAI 1948	: Brunei & East Malaysia (Sarawak & Sadah)
071: KERTAU 1948	: West Malaysia & Singapore	157: TOKYO	: Japan
072: LA REUNION	: Mascarene Is.	158:	: Korea
073: L. C. 5 ASTRO	: Cayman Brac Is.	159:	: Okinawa
074: LIBERIA 1964	: Liberia	160: TRISTAN ASTRO 1968	: Tristan da Cunha
075: LUZON	: Philippines (excl. Mindanao Is.)	161: VITI LEVU 1916	: Viti Levu Is. (Fiji Islands)
076:	: Mindanao Is.	162: WAKE-ENIWETOK 1960	: Marshall Islands
077: MAHE 1971	: Mahe Is.	163: ZANDERIJ	: Surinam
078: MARCO ASTRO	: Salvage Islands	164: BUKIT RIMPAH	: Bangka & Belitung Islands (Indonesia)
079: MASSAWA	: Eritrea (Ethiopia)	165: CAMP AREA ASTRO	: Camp Mcmurdo Area, Antarctica
080: MERCHICH	: Morocco	166: G. SEGARA	: Kalimantan Is. (Indonesia)
081: MIDWAY ASTRO 1961	: Midway Is.	167: HERAT NORTH	: Afghanistan
082: MINNA	: Nigeria	168: HU-TZU-SHAN	: Taiwan
083: NAHRWAN	: Masirah Is. (Oman)	169: TANANARIVE OBSERVATORY 1925: Madagascar	: Madagascar
084:	: United Arab Emirates	170: YACARE	: Uruguay
085:	: Saudi Arabia	171: RT-90	: Sweden
086: NAMIBIA	: Namibia		

DGPS REFERENCE STATIONS

The following table shows the updated DGPS reference stations (as of May 1998), including the expected stations.

Location	Freq.	Latitude	Longitude	MSK Rate	Country
ALEXANDRIA	305	N38.45	W77.07	100	VA,USA
ANNETTE ISLAND	323	N55.04	W131.36	100	AK,USA
APPLETON	300	N45.47	W121.19	100	WA,USA
ARANSAS PASS	304	N27.50	W97.04	100	TX,USA
BARBERS PT	325	N21.18	W158.07	100	HI,USA
BASS HARBOR	316	N44.13	W68.20	100	ME,USA
BRUNSWICK	316	N43.53	W69.57	100	ME,USA
BUFFALO	322	N42.52	W78.54	100	NY,USA
C.MENDOCINO	292	N40.26	W124.24	100	CA,USA
CAPE CANAVERAL	289	N28.28	W80.33	100	FL,USA
CAPE HENLOPEN	298	N38.47	W75.05	200	DE,USA
CAPE HENRY	289	N36.56	W76.00	100	VA,USA
CAPE HINCHEN-BROOK	292	N60.14	W146.39	100	AK,USA
CHARLESTON	298	N32.45	W79.51	100	SC,USA
CHATHAM	325	N41.40	W69.57	200	MA,USA
CHEBOYGAN	292	N45.39	W84.28	200	MI,USA
COLD BAY	289	N55.06	W162.32	100	AK,USA
DETROIT	319	N42.18	W83.06	200	MI,USA
DULUTH	296	N46.47	W92.05	100	MN,USA
EGMONT KEY	312	N27.36	W82.46	200	FL,USA
ENGLISH TURN	293	N29.53	W89.57	200	LA,USA
FORT MACON	294	N34.42	W76.41	100	NC,USA
FORT STEVENS	287	N46.12	W123.57	100	OR,USA
GALVESTON	296	N29.20	W94.44	100	TX,USA
GUSTAVUS	288	N58.25	W135.42	100	AK,USA
ISABELLA	295	N18.28	W67.04	100	PR,USA
KANSAS CITY	305	N39.07	W95.25	200	MO,USA
KENAI	310	N60.40	W151.21	100	AK,USA
KEY WEST	286	N24.00	W82.00	100	FL,USA
KODIAK	313	N57.37	W152.12	100	AK,USA
KOKOLE POINT	300	N21.59	W159.46	200	HI,USA
MEMPHIS	310	N35.28	W90.12	200	TN,USA
MIAMI	322	N25.44	W80.10	100	FL,USA
MILLERS FERRY	320	N32.05	W87.24	200	AL,USA
MILWAUKEE	297	N43.00	W87.53	100	WI,USA
MOBILE PT	300	N30.14	W88.01	100	AL,USA
MONTAUK PT	293	N41.04	W71.52	100	NY,USA
NEEBISH IS.	309	N46.19	W84.09	200	MI,USA
OMAHA	298	N41.47	W95.55	200	NE,USA
PIGEON PT	287	N37.11	W122.24	100	CA,USA
PORTSMOUTH	288	N43.04	W70.43	100	NH,USA
POTATO PT	298	N61.04	W146.42	100	AK,USA
PRESQUE ILE	293	N45.21	W83.30	100	MI,USA
PT ARGUELLO	321	N34.35	W120.39	100	CA,USA

Location	Freq.	Latitude	Longitude	MSK Rate	Country
PT BLUNT	310	N37.51	W122.25	200	CA,USA
PT LOMA	302	N32.40	W117.15	100	CA,USA
REEDY POINT	309	N39.34	W75.34	200	DE,USA
ROBINSON PT	323	N47.23	W122.23	200	WA,USA
ROCK ISLAND	311	N42.00	W90.14	200	IA,USA
SAGINAW BAY	301	N43.38	W83.50	100	MI,USA
SALLISAW	299	N35.22	W94.49	200	OK,USA
SANDY HOOK	286	N40.28	W74.00	200	NJ,USA
SEUL CHOIX PT	322	N45.55	W85.55	200	MI,USA
ST LOUIS	322	N38.37	W89.46	200	MO,USA
ST PAUL	317	N44.18	W91.54	200	MN,USA
STURGEON BAY	322	N44.48	W87.19	100	WI,USA
UPOLU PT	285	N20.15	W155.53	100	HI,USA
UPPER KEWEENAW	298	N47.14	W88.38	100	MI,USA
VICKSBURG	313	N32.20	W90.55	200	MS,USA
WHIDBEY IS	302	N48.19	W122.42	100	WA,USA
WHITEFISH PT	318	N46.46	W84.57	100	MI,USA
WILDWOOD	301	N38.57	W74.52	200	NJ,USA
WISCONSIN PT	296	N46.43	W92.01	100	WI,USA
YOUNGSTOWN	322	N43.14	W78.58	100	NY,USA
ALERT BAY	309	N50.35	W126.55	200	CANADA
AMPHITRITE POINT	315	N48.55	W125.32	200	CANADA
BASSANO	317	N50.47	W112.27	200	CANADA
CAPE NORMAN	310	N51.29	W55.49	200	CANADA
CAPE RACE	315	N46.45	W53.11	200	CANADA
CAPE RAY	290	N47.38	W59.14	200	CANADA
CAPE SPEAR	314.5	N47.31	W52.37	100	CANADA
CARDINAL	306	N44.47	W75.25	200	CANADA
CRANBERRY ISLAND	286	N45.19	W60.55	100	CANADA
EAST POINT	314	N46.27	W61.58	100	CANADA
FOX ISLAND	307	N45.19	W61.04	200	CANADA
LAUZON	309	N46.48	W71.09	200	CANADA
MOISIE	313	N50.12	W66.07	200	CANADA
PARTRIDGE ISLAND	295	N45.14	W66.03	200	CANADA
PISTOLET BAY	317	N51.29	W55.48	100	CANADA
RICHMOND(ATKINSON)	320	N49.10	W123.07	200	CANADA
POINT PETRIE	303	N43.50	W77.09	100	CANADA
PORT AUX BASQUES	290	N47.34	W59.09	100	CANADA
PORT WELLER	302	N43.14	W79.13	100	CANADA
PT.ESCUMINAC	319	N47.40	W64.47	200	CANADA
RACE ROCKS	309	N48.18	W123.31	100	CANADA
RIGOLET	299	N54.15	W58.30	200	CANADA
RIVIERE DU LOUP	300	N47.45	W69.36	200	CANADA
SANDSPIT	300	N53.14	W131.48	200	CANADA
SOMBRA	306	N42.42	W89.29	100	CANADA
ST JEAN SUR RICHELIEU	296	N45.19	W73.18	200	CANADA
TRIPLE ISLAND	308	N54.17	W130.53	100	CANADA
TROIS RIVIERES	321	N46.23	W72.27	200	CANADA
WATROUS	321	N50.40	W105.26	200	CANADA
WESTERN HEAD	312	N43.59	W64.39	200	CANADA
WIARTON	286	N44.45	W81.07	200	CANADA
WINNIPEG	312	N49.50	W97.30	200	CANADA
ST.DAVIDS HEAD	323	N32.22	W64.39	100	BERMUDA

Location	Freq.	Latitude	Longitude	MSK Rate	Country
OOSTENDE PHARE	311.5	N51.14	E02.55	100	BELGIUM
BLAAVANDS HUK	296.5	N55.34	E08.05	100	DENMARK
HAMMERODDE	289	N55.18	E14.46	100	DENMARK
SKAGEN	298.5	N57.44	E10.35	100	DENMARK
RISTNA LT	307	N58.56	E22.04	100	ESTONIA
MANTYLUOTO	298	N61.36	E21.28	200	FINLAND
OUTOKUMPU	293.5	N62.41	E29.01	200	FINLAND
PORKKALA	285	N59.58	E24.23	200	FINLAND
PUUMALA	301.5	N61.24	E28.14	200	FINLAND
TURKU	304	N60.26	E22.13	200	FINLAND
CAP BEAR	304.5	N42.31	E03.08	100	FRANCE
CAP FERRET	287	N44.39	E01.15	100	FRANCE
ECKMUHL	312.5	N47.48	W04.23	100	FRANCE
GATTEVILLE	297.5	N49.42	W01.16	100	FRANCE
LES BALEINES	299.5	N46.15	W01.34	100	FRANCE
PORQUEROLLES	314.5	N42.59	E06.12	100	FRANCE
REVELLATA	294.5	N42.35	E08.46	100	FRANCE
SAINT MATHIEU	291.5	N48.19	W04.46	100	FRANCE
HELGOLAND	313	N54.11	E07.53	200	GERMANY
WUSTROW	314.5	N54.20	E12.23	200	GERMANY
BJARGTANGAR	289	N65.30	W24.32	100	ICELAND
DJUPIVOGUR	295.5	N64.39	W14.16	100	ICELAND
RAUFARHOFN	301.5	N66.27	W15.57	100	ICELAND
REYKJANES	292.5	N63.49	W22.42	100	ICELAND
SKAGATA	304.5	N66.07	W20.06	100	ICELAND
SKARDSFJARA	313	N63.31	W17.59	100	ICELAND
LOOP HEAD	312	N52.34	W09.56	100	IRELAND
MIZEN HEAD	300.5	N51.27	W09.49	100	IRELAND
TORY ISLAND	313.5	N55.16	W08.15	100	IRELAND
VENTSPILS	308.5	N57.22	E21.31	100	LATVIA
HOEK VAN HOLLAND	287.5	N51.59	E04.07	200	HOLLAND
VLIELAND(AMELAND)	299.5	N53.27	E05.38	200	HOLLAND
ANDENES	284.5	N69.19	E16.07	100	NORWAY
FAERDER	288	N59.02	E10.32	100	NORWAY
FRUHOLMEN	309.5	N71.06	E23.59	100	NORWAY
HALTEN	313.5	N64.10	E09.25	100	NORWAY
LISTA	301	N58.07	E06.34	100	NORWAY
SKLINNA	288.5	N65.12	E11.00	100	NORWAY
SKOMVAER	300	N67.25	E11.53	100	NORWAY
SVINOEY	293.5	N62.20	E05.16	100	NORWAY
TORSVAAG	291.5	N70.15	E19.31	100	NORWAY
TORUNGEN	292.5	N58.23	E08.48	100	NORWAY

Location	Freq.	Latitude	Longitude	MSK Rate	Country
UTSIRA	307	N59.19	E04.52	100	NORWAY
UTVAER	300	N61.02	E04.31	100	NORWAY
VARDOE	307	N70.23	E31.09	100	NORWAY
DZIWNOW	288	N54.01	E14.44	100	POLAND
ROZEWIE	311	N54.49	E18.20	100	POLAND
CABO DE LA NAO	284.5	N38.44	E00.14	0	SPAIN
CABO DE PALOS	313.5	N37.38	W00.41	0	SPAIN
CABO FINISTERRE	289	N42.53	W09.16	0	SPAIN
CABO GATA	298.5	N36.43	W02.11	0	SPAIN
CABO PENAS	297	N43.39	W05.51	0	SPAIN
CABO SALOU	289	N41.03	E01.10	0	SPAIN
CABO SAN SEBASTIAN	290.5	N41.53	E03.12	0	SPAIN
CASTELLON	311	N39.58	E00.01	0	SPAIN
CEUTA	311.5	N35.54	W05.18	0	SPAIN
ESTACA DE BARES	310	N43.47	W07.41	0	SPAIN
LA ENTALLADA	292.5	N28.13	W13.56	0	SPAIN
MACHICHACO	285	N43.27	W02.45	0	SPAIN
MAHON	292.5	N39.52	E04.18	0	SPAIN
MALAGA	304.5	N36.43	W04.25	0	SPAIN
PUNTA DE CALA FIGUERA	286	N39.27	E02.31	0	SPAIN
ROTA	302.5	N36.38	W06.23	0	SPAIN
TENERIFE	287.5	N28.30	W16.30	0	SPAIN
ALMAGRUNDET	287	N59.09	E19.10	200	SWEDEN
BJUROKLUBB	303.5	N64.29	E21.35	200	SWEDEN
HJORT UDDE	297	N58.38	E12.40	200	SWEDEN
HOBURG	302	N56.55	E18.09	200	SWEDEN
KULLEN	293.5	N56.18	E12.27	200	SWEDEN
OERSKAER	291.5	N60.32	E18.23	200	SWEDEN
SKAGS UDDE	306.5	N63.11	E19.01	200	SWEDEN
BUTT OF LEWIS	294	N58.31	W06.16	100	U.K.
FLAMBOROUGH HEAD	302.5	N54.07	W00.05	100	U.K.
GIRDLE NESS	311	N57.08	W02.03	100	U.K.
LIZARD	284	N49.58	W05.12	100	U.K.
NASH POINT	299	N51.24	W03.34	100	U.K.
NORTH FORELAND	310.5	N51.23	E01.27	100	U.K.
POINT LYNAS	305	N53.25	W04.17	100	U.K.
RHINNS OF ISLAY	293.5	N55.40	W06.31	100	U.K.
ST.CATHERINE'S	293.5	N50.35	W01.18	100	U.K.
SUMBURGH HEAD	304	N59.52	W01.16	100	U.K.
AL BANDAR	298	N28.07	E50.39	200	BAHRAIN
MINA AL AHMADI	295	N29.07	E48.08	200	KUWAIT
ADU DHABI	314	N24.06	E52.56	200	U.A.E.
RAS AL KHAIMAH	292	N25.59	E56.04	200	U.A.E.

Location	Freq. (kHz)	Latitude	Longitude	MSK Rate	Country
ABASHIRI	309	N44.00	E144.18	200	JAPAN
INUBOSAKI	288	N34.17	E136.54	200	JAPAN
ESAKI	320.5	N34.36	E135.00	200	JAPAN
HAMADA	305	N34.53	E132.02	200	JAPAN
HACHIJOJIMA	302	N33.05	E139.51	200	JAPAN
HEKURAJIMA	295	N37.51	E136.55	200	JAPAN
INUBOZAKI	295	N35.42	E140.52	200	JAPAN
KINKAZAN	316	N38.17	E141.35	200	JAPAN
KUSIROZAKI	288	N43.04	E145.09	200	JAPAN
MATSUMAE	309	N41.25	E140.05	200	JAPAN
MEJIMA	302	N31.59	E128.21	200	JAPAN
MUROTO MISAKI	295	N33.15	E134.11	200	JAPAN
OHAMA	321	N34.05	E132.59	200	JAPAN
OSEZAKI	302	N32.37	E128.36	200	JAPAN
SAKATA	288	N38.57	E139.50	200	JAPAN
SETO	320	N33.26	E132.13	200	JAPAN
SHAKOTAN MISAKI	316	N43.22	E140.28	200	JAPAN
SHIRIYAZAKI	302	N41.26	E141.28	200	JAPAN
SOUYA MISAKI	295	N45.31	E141.56	200	JAPAN
TOI MISAKI	309	N31.22	E131.20	200	JAPAN
TURUGIZAKI	309	N35.08	E139.41	200	JAPAN
WAKAMIYA	295	N33.52	E129.41	200	JAPAN
CHANGGI	310	N36.05	E129.34	100	KOREA
CHINDO	290	N34.13	E125.58	100	KOREA
CHUMUNJIN	295	N37.54	E128.50	100	KOREA
KOMUNDO	287	N34.00	E127.20	100	KOREA
OCHONGDO	295	N36.07	E125.58	100	KOREA
PALMIDO	313	N37.21	E126.30	100	KOREA
YONGDO	300	N35.03	E129.06	100	KOREA
KAU YI CHAU	289	N22.15	E114.04	200	HONG KONG
CAPE SCHANCK	314	S38.30	E144.53	200	AUSTRALIA
HORN ISLAND	320	S10.36	E142.17	200	AUSTRALIA
KARRATHA	304	S20.45	E116.27	200	AUSTRALIA
MACKAY	315	S21.06	E149.13	200	AUSTRALIA
SYDNEY	308	S33.59	E150.59	200	AUSTRALIA
ABROLHOS	290	S17.57	W38.41	100	BRAZIL
ARACAJU	320	S10.58	W37.02	100	BRAZIL
CALCANHAR	305	S05.09	W35.29	100	BRAZIL
CANIVETE	310	N00.30	W50.24	100	BRAZIL
I.MOELA	305	S24.02	W46.15	100	BRAZIL
PONTA DE SAO MARCOS	300	S02.29	W44.18	100	BRAZIL
RIO GRANDE	290	S32.08	W52.06	100	BRAZIL
SANTA MARTA	310	S28.36	W48.48	100	BRAZIL
SAO TOME	300	S22.02	W41.03	100	BRAZIL

Location	Freq. (kHz)	Latitude	Longitude	MSK Rate	Country
SAN BERNARDO	317.5	S36.22	W60.03	100	ARGENTINA
SAN CARLOS CENTRO	297.5	S31.58	W60.55	100	ARGENTINA
AFRICA	291.5	N56.11	E163.21	100	RUSSIA
ALEVINA	303.5	N58.50	E151.21	100	RUSSIA
ANAPSKY	315.5	N44.53	E37.18	100	RUSSIA
ANDREA	291.5	N76.44	E110.27	100	RUSSIA
ASTRAHNASKY	291.5	N44.28	E48.01	100	RUSSIA
BALTIYSK	298.5	N54.41	E19.59	100	RUSSIA
BEGICHEV	300.5	N47.31	E112.15	100	RUSSIA
CAMENKA	318.5	N69.28	E161.14	100	RUSSIA
CANIN NOSE	285.5	N68.38	E43.18	100	RUSSIA
CARAGINSKY	301.5	N58.33	E163.33	100	RUSSIA
CORSAKOVSKY	312.5	N46.37	E142.48	100	RUSSIA
COTELNY	310.5	N75.59	E137.53	100	RUSSIA
CRUTOGOROVA	300.5	N55.05	E155.35	100	RUSSIA
DEDGNEVA	303.5	N66.01	E169.43	100	RUSSIA
DGEDGINSKY	298.5	N65.13	E36.49	100	RUSSIA
ELIZAROVA	318.5	N54.25	E143.43	100	RUSSIA
ENISEY	315.5	N68.25	E86.18	100	RUSSIA
GAMOV	306.5	N42.33	E131.13	100	RUSSIA
INDYGIRSKY	324.5	N71.16	E150.17	100	RUSSIA
OLENIY	294.5	N72.35	E77.39	100	RUSSIA
PETROPAVLOVSKY	291.5	N52.33	E158.42	100	RUSSIA
RUSSIAN CAT	315.5	N64.34	E178.33	100	RUSSIA
SET.NAVOLOCK	318.5	N69.24	E33.03	100	RUSSIA
SHEPELEVSKIY	298.5	N59.59	E29.09	100	RUSSIA
STERLEGOV	318.5	N75.24	E88.45	100	RUSSIA
STOLBOVOY	306.5	N74.10	E135.27	100	RUSSIA
TONKY	303.5	N69.51	E61.06	100	RUSSIA
VAN DER LINDA	312.5	N45.35	E149.24	100	RUSSIA
VASILIEVA	294.5	N50.00	E155.23	100	RUSSIA
VIZE	294.5	N79.30	E76.59	100	RUSSIA
VRANGELIA	309.5	N70.59	E178.29	100	RUSSIA
YARANGAI	291.5	N69.54	E170.32	100	RUSSIA

LORAN C CHAINS

Chain	GRI	S1	S2	S3	S4	S5
Central Pacific	4990	11	29	--	--	--
Canadian East Coast	5930	11	25	38	--	--
Commando Lion (Korea)	5970	11	31	42	--	--
Canadian West Coast	5990	11	27	41	--	--
South Saudi Arabia	7170	11	26	39	52	--
Labrador Sea	7930	11	26	--	--	--
Eastern Russia	7950	11	30	46	61	--
Gulf of Alaska	7960	11	26	44	--	--
Norwegian Sea	7970	11	26	46	60	--
Southeast USA	7980	11	23	43	59	--
Mediterranean Sea	7990	11	29	47	--	--
Western Russia	8000	10	25	50	65	--
North Central USA	8290	11	27	42	--	--
North Saudi Arabia	8990	11	25	40	56	69
Great Lakes	8970	11	28	44	59	--
South Central USA	9610	11	25	40	52	65
West Coast USA	9940	11	27	40	--	--
Northeast USA	9960	11	25	39	54	--
Northeast Pacific (old)	9970	11	30	55	81	--
Icelandic	9980	11	30	--	--	--
North Pacific	9990	11	29	43	--	--
Suez	4991	10	24			
England, France	8940	12	30			
Northwest Pacific	8930	11	30	50	70	
Newfoundland East Coast	7270	11	25			
Lessay	6731	10	39			
BØ	7001	11	27			
Sylt	7499	11	26			
Ejde	9007	10	23	38		
Saudia Arabia North	8830	11	25	39	56	
Saudia Arabia South	7030	11	25	37	55	

DECCA CHAINS

Chain No.	Chain	Chain code	Location
01	South Baltic	0A	Europe
02	Vestlandet	0E	"
03	Southwest British	1B	"
04	Northumbrian	2A	"
05	Holland	2E	"
06	North British	3B	"
07	Lofoten	3E	"
08		3F	"
09	North Baltic	4B	"
10	North West	4C	"
11	Trondelag	4E	"
12	English	5B	"
13	North Bothnian	5F	"
14	Southern Spanish	6A	"
15	North Scottish	6C	"
16	Gulf of Finland	6E	"
17	Danish	7B	"
18	Irish	7D	"
19	Finnmark	7E	"
20	French	8B	"
21	South Bothnian	8C	"
22	Hebridean	8E	"
23	Frisian Islands	9B	"
24	Helgeland	9E	"
25	Skagerrak	10B	"
26	North Persian Gulf	5C	Persian Gulf & India
27	South Persian Gulf	1C	"
28	Bombay	7B	"
29	Calcutta	8B	"
30	Bangladesh	6C	"
31	Saliyah	2F	"
32	Hokkaido	9C	Japan
33	Tohoku	6C	"

Chain No.	Chain	Chain code	Location
34	Kanto	8C	Japan
35	Shikoku	4C	"
36	Hokuriku	2C	"
37	Kita Kyushu	7C	"
38	Namaqualand	4A	Southern Africa
39	Cape	6A	"
40	Eastern Province	8A	"
41	South West Africa	9C	"
42	Natal	10C	"
43	Dampier	8E	Australia
44	Port Headland	4A	"
45	Anticosti	9C	Northern America
46	East Newfoundland	2C	"
47	Cabot Strait	6B	"
48	Nova Scotia	7C	"

MENU TREE

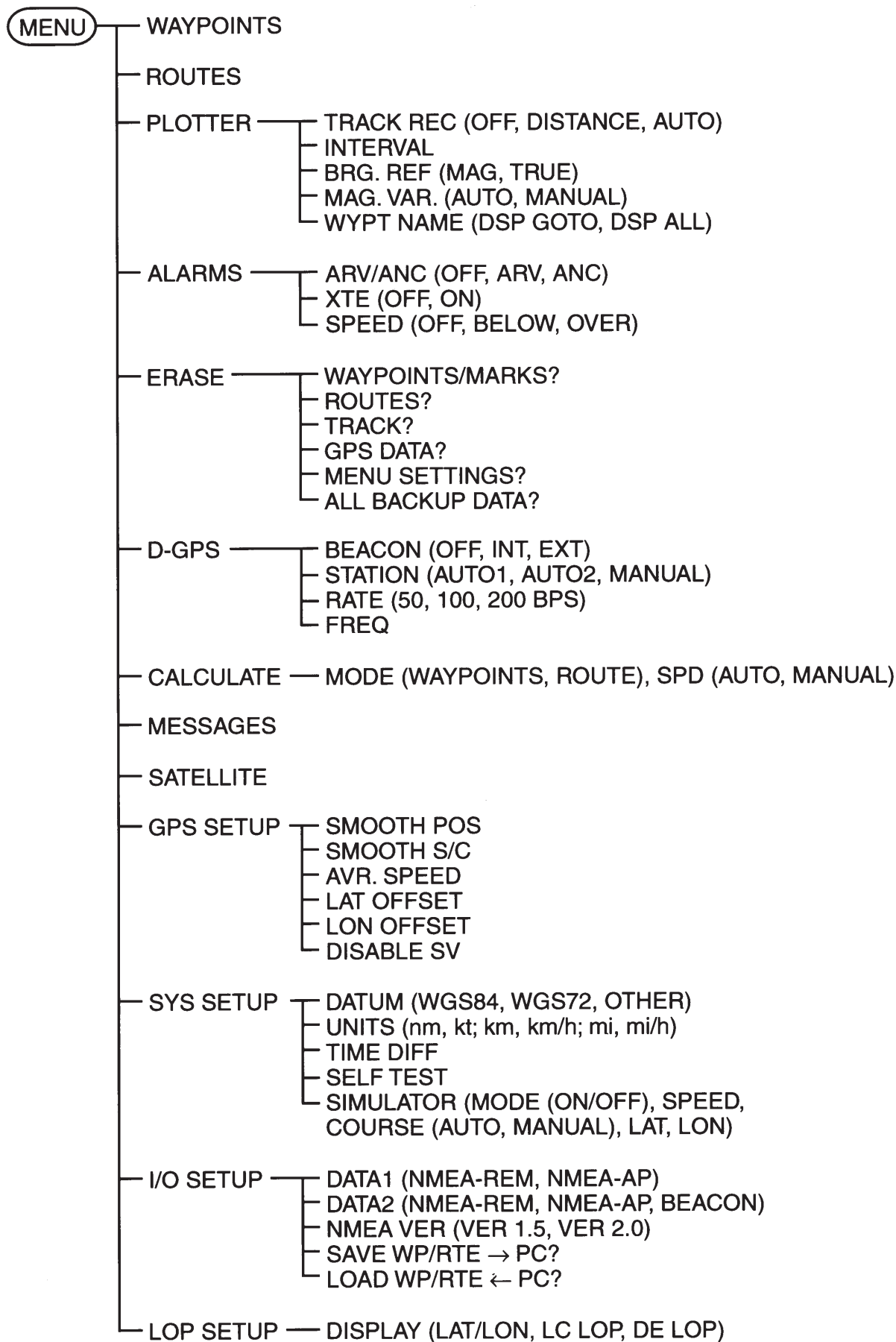

A) Mast mounting

a) Use mast mounting kit CP20-01111

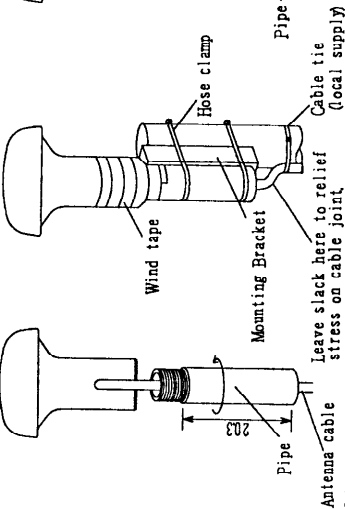

Notes

- 1) Fasten pipe to antenna first then fix them to mast
- 2) When fixing antenna to pipe, turn pipe; not the antenna. Turning the antenna may twist the cable and place stress on connector.

b) Use a pipe only.

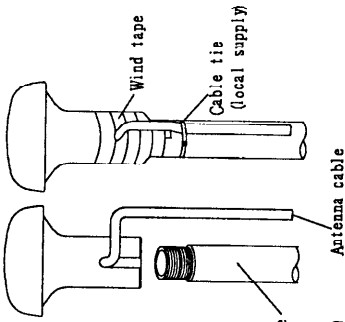

B) Antenna base mounting

Use optional antenna base No.13-QA300 or No.13-QA310.

Inclination	-5° to 33°	32° to 65°	65° to 98°
	Right angle antenna base No.13-QA300 (code No. 000-803-239)	L-type antenna base No.13-QA310 (code No. 000-803-240)	

C) Handrail mounting

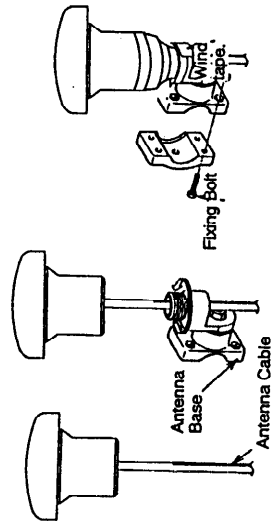

Use handrail mounting base No.13-RCS160 (Code No. 000-861-114, option). The diameter of the handrail may be from $\phi 19\text{mm}$ to $\phi 32\text{mm}$.

NOTES

- 1) Fasten antenna base to antenna first then fix them to handrail.
- 2) When fixing antenna to antenna base, turn antenna base; not the antenna. Turning the antenna may twist the cable and place stress on connector.

Mounting location

The figure below shows the recommended separation distances from other antennas to avoid mutual interference.

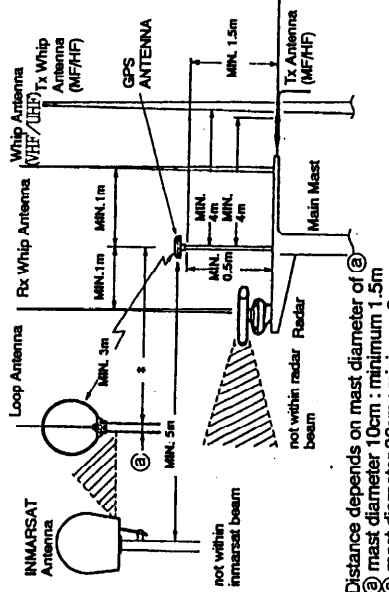

* Distance depends on mast diameter of
 ① mast diameter 10cm : minimum 1.5m
 ② mast diameter 30cm : minimum 3m

Mounting dimensions of antenna base (option)

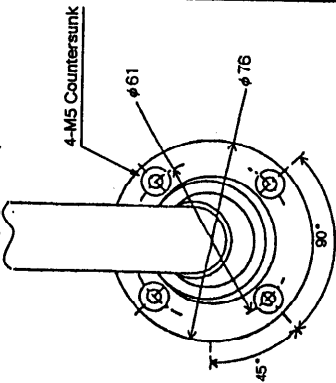

THREAD DIMENSION (for PIPE)

Thread Type: 1x14UN31B
 Threads per 25.4 mm (1 inch) : 14
 Pitch: 1.8143 mm
 Thread Length: 19 mm or more
 Pitch Diameter: 24.17 mm

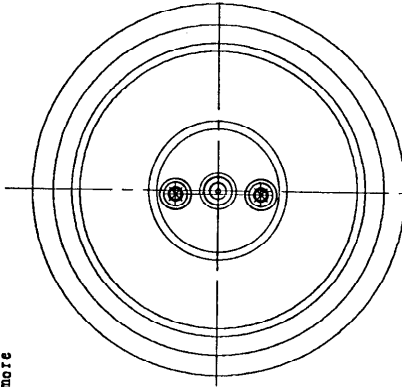
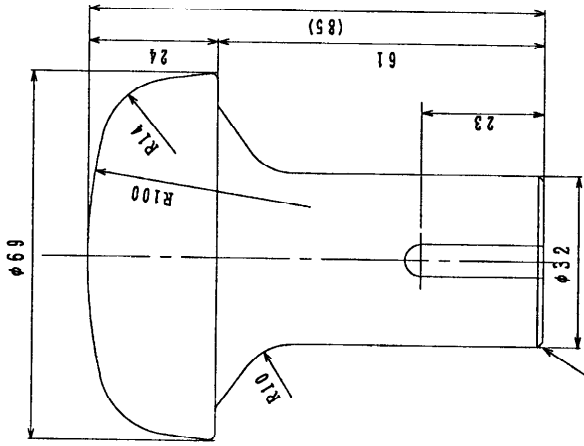

DRAWN: 2017.1.10-MSAK
 CHECKED: 2018.1.10-MSAK
 APPROVED: 2018.1.10-MSAK
 SCALE: MASS 0.3 kg

TITLE	GPA-017
名称	空中機部
外寸図	
NMB	ANTENNA UNIT
OUTLINE DRAWING	

A) Mast mounting

a) Use mast mounting kit CP20-0111L

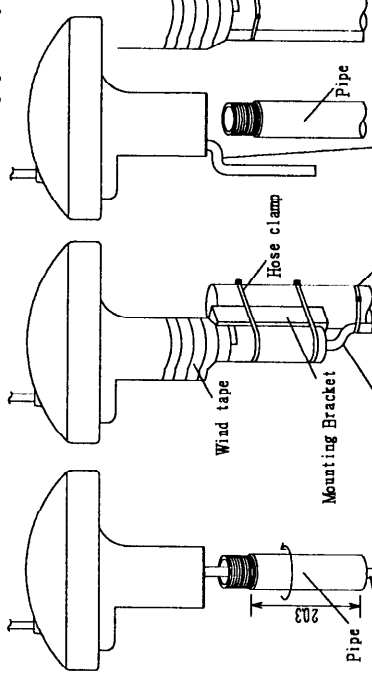

Notes
 1) Fasten pipe to antenna first, then fix them to mast.
 2) When fixing antenna to pipe, turn pipe; not the antenna. Turning the antenna may twist the cable and place stress on connector.

b) Use a pipe only.

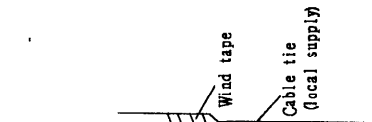

Keep cable aside to avoid injury from pipe.

B) Antenna base mounting

Use optional antenna base No.13-QA300 or No.13-QA310.

Inclination	-5° to 33°	32° to 65°	65° to 98°
	Right angle antenna base No.13-QA300 (code No. 000-803-239)	L-type antenna base No.13-QA310 (code No. 000-803-240)	

C) Handrail mounting

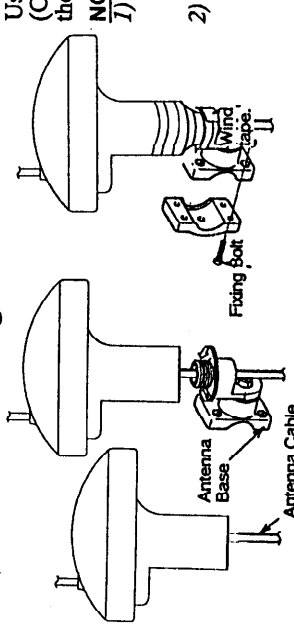

Use handrail mounting base No.13-RCS160 (Code No. 000-861-114, option). The diameter of the handrail may be from $\phi 19\text{mm}$ to $\phi 32\text{mm}$.

NOTES

- 1) Fasten antenna base to antenna first then fix them to handrail.
- 2) When facing antenna to antenna base, turn antenna base; not the antenna. Turning the antenna may twist the cable and place stress on connector.

Mounting location

The figure below shows the recommended separation distance from antennas to avoid mutual interference.

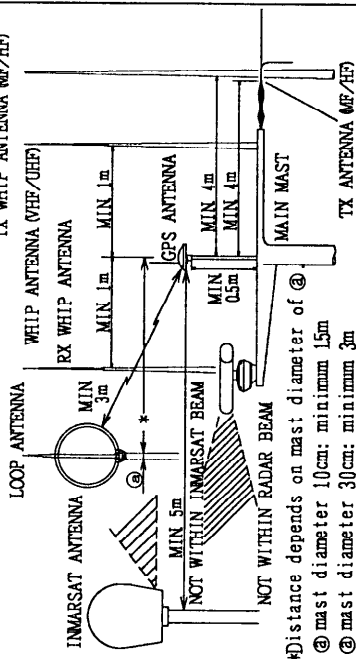

Mounting dimensions of antenna base (option)

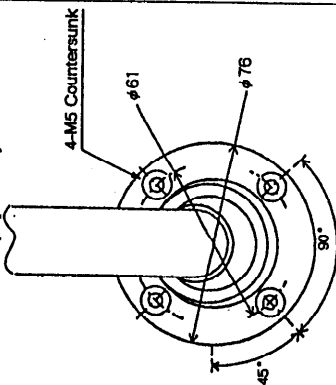

THREAD DIMENSION (for PIPE)

Thread Type: 1x1/4UNF1B
 Threads per 25.4 mm (1 inch): 14
 Pitch: 1.8143 mm
 Thread Length: 19 mm or more
 Pitch Diameter: 24.17 mm

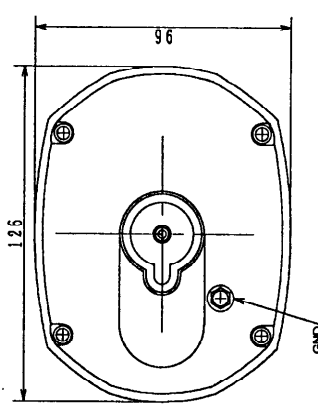
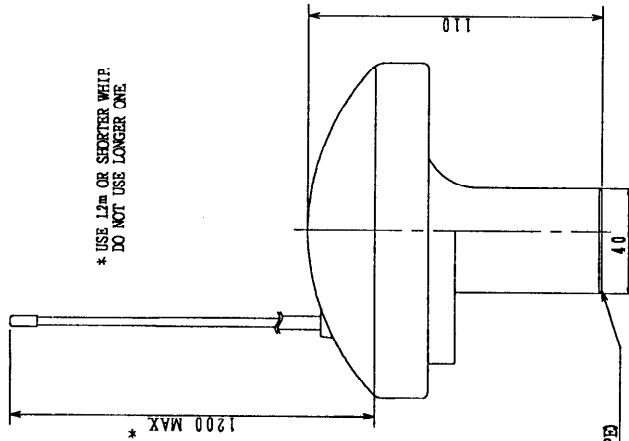

DRAWN	Y. Y. TAMASAKI	TITLE	GPA-018
CHECKED	Y. Y. TAMASAKI	名 称	空中線部
APPROVED	Y. Y. TAMASAKI	外 寸 図	
SCALE	MASS 1.5 kg	NAME	ANTENNA UNIT
WORK	C1385-G01-B		OUTLINE DRAWING

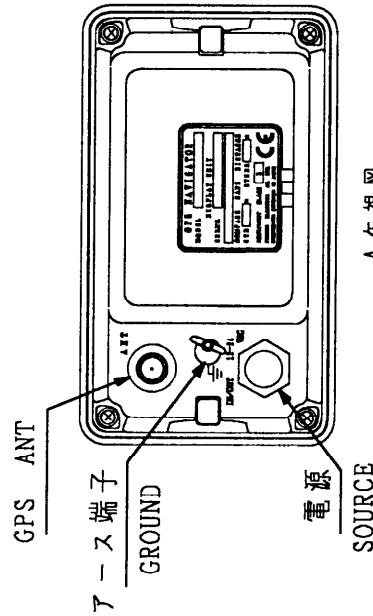
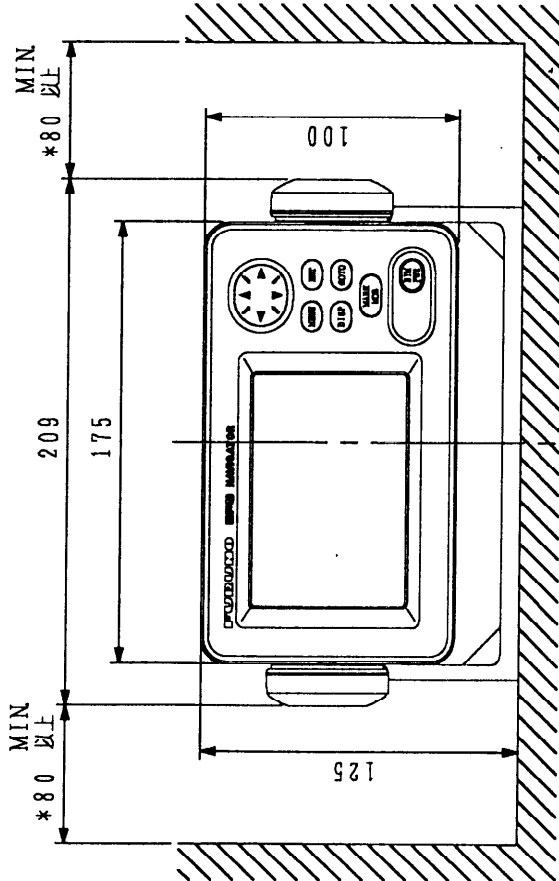
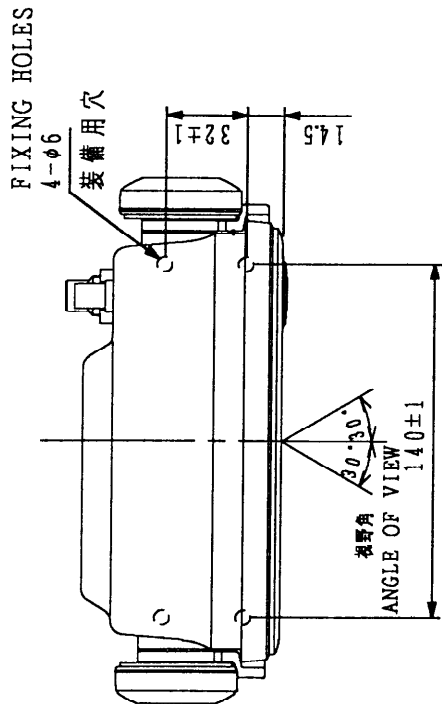

A 矢視図
VIEW A

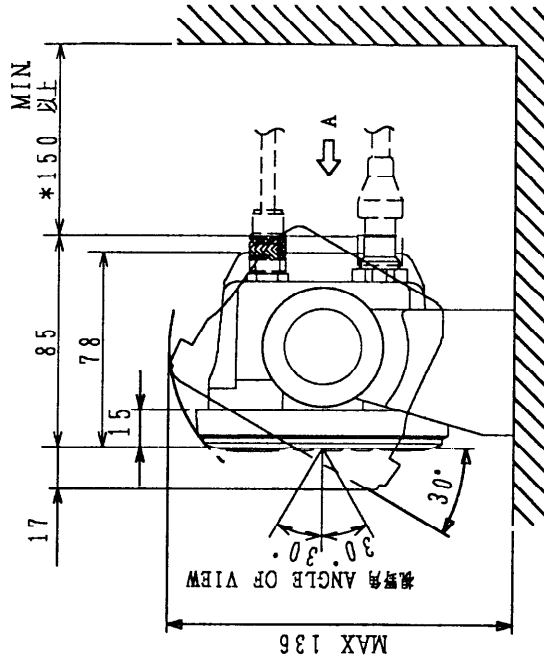

幅	DIMENSIONS	公差 TOL
L ≤ 50		± 1 mm
50 < L ≤ 100		± 2 mm
100 < L ≤ 500		± 3 mm
500 < L ≤ 1000		± 4 mm
1000 < L ≤ 2000		± 5 mm
2000 < L ≤ 4000		± 7 mm
4000 < L ≤ 8000		± 10 mm
8000 < L		± 15 mm

表 1
TABLE 1

注記 1) *印寸法は最小サービス空間寸法とする。

NOTE 1: DIMENSIONS WITH "*" INDICATES RECOMMENDED SERVICE CLEARANCE.

DRAWN Dec. 9 '97	TITLE GP-30/35
CHECKED I. YAMASAKI	名 稱 G P S 受信機 指示部
APPROVED Dec. 11 '97 K. MISONO	外 寸 図
SCALE Dec. 11 '97 H. YAMAGUCHI	NAME GPS RECEIVER DISPLAY UNIT
MASS 0.6 kg	OUTLINE DRAWING
DWG No. C.438.4-G01-B	20-016-1000-G2

紙 図 DIMENSIONS	公差 TOL
$L \leq 50$	$\pm 1 \text{ mm}$
$50 < L \leq 100$	$\pm 2 \text{ mm}$
$100 < L \leq 500$	$\pm 3 \text{ mm}$
$500 < L \leq 1000$	$\pm 4 \text{ mm}$
$1000 < L \leq 2000$	$\pm 5 \text{ mm}$
$2000 < L \leq 4000$	$\pm 7 \text{ mm}$
$4000 < L \leq 8000$	$\pm 10 \text{ mm}$
$8000 < L$	$\pm 15 \text{ mm}$

表 1
TABLE 1

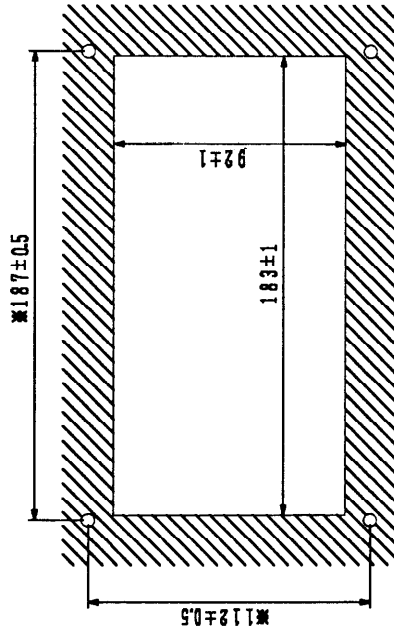
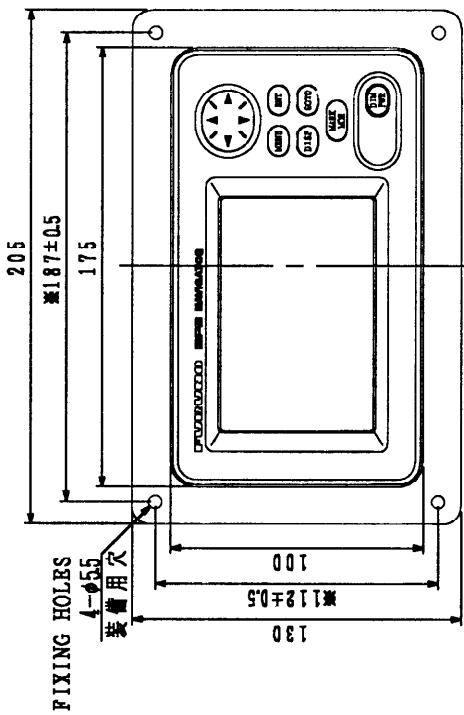
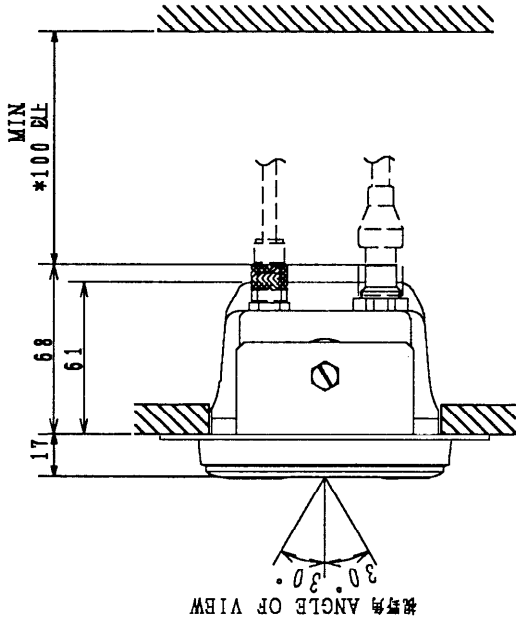

注 記
 1) 取付寸法は取付穴位置寸法とする。
 2) 取付ネジはタッペンネジ呼び径5×2.0を使用。
 3) *印寸法は最小サージ空間寸法とする。

NOTE
 1: ** INDICATES DIMENSION OF FIXING HOLES PITCH.
 2: USE $\phi 5 \times 2.0$ TAPPING SCREWS FOR FIXING THE UNIT.
 3: DIMENSIONS WITH ** INDICATES RECOMMENDED SERVICE CLEARANCE.

DRAWN	Dec 25 97 I. YAMASAKI	TITLE	GP-30/35
CHECKED	Dec 25 97 Akashiwaki	名称	指示部 フラッシュマウント F
APPROVED	Dec 25 97 H. Yamaguchi	外寸図	
SCALE	1:1 MASS 0.6 kg	NAME	DISPLAY UNIT FLUSH MOUNT F
DMCA	C4384-G02-B	OUTLINE DRAWING	
	20-016-1050-G1		

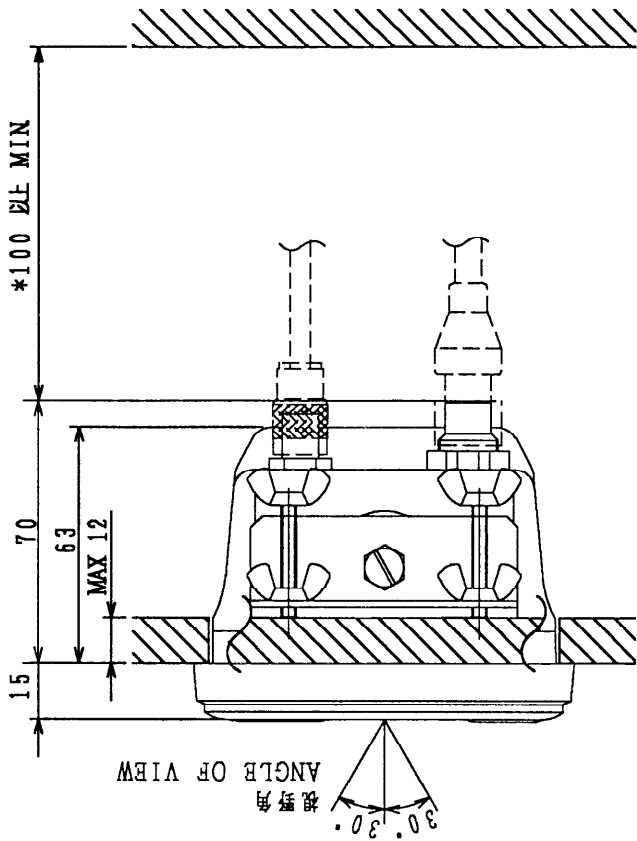

標 尺 DIMENSIONS	公 差 TOL
L ≤ 50	± 1 mm
50 < L ≤ 100	± 2 mm
100 < L ≤ 500	± 3 mm
500 < L ≤ 1000	± 4 mm
1000 < L ≤ 2000	± 5 mm
2000 < L ≤ 4000	± 7 mm
4000 < L ≤ 8000	± 10 mm
8000 < L	± 15 mm

表 1
TABLE 1

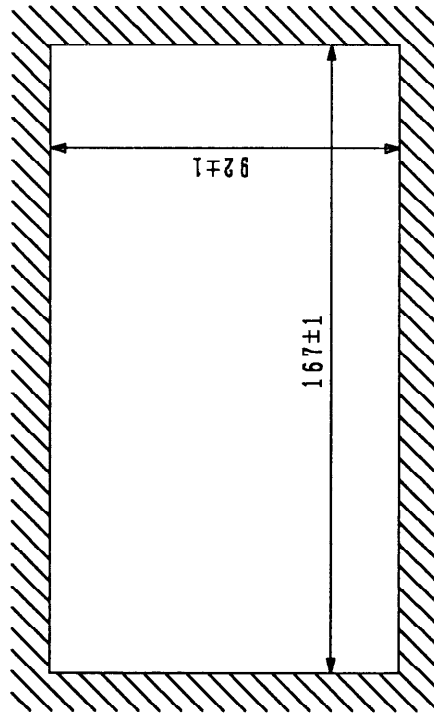
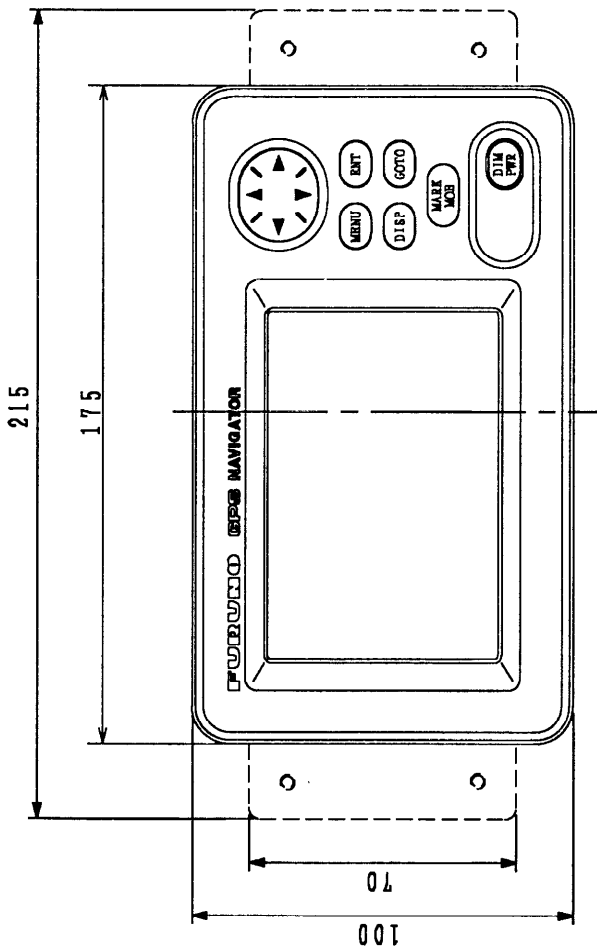

取付 穴 寸 法 図 (参 考 図)
CUTTING DIMENSION

注 記

1) *印寸法は最小サービスマウントとする。

NOTE

1: DIMENSION WITH "*" INDICATES RECOMMENDED SERVICE CLEARANCE

DRAWN	Dec 25 '97 T. YAMASAKI	TITLE	GP-30/35
CHECKED	Dec 25 '97 K. KAWANOTO	名称	指示部 フラッシュマウントS
APPROVED	Dec 25 '97 M. YAMAGUCHI	外寸図	
SCALE	MASS 0.6 kg	NAME	DISPLAY UNIT FLUSH MOUNT S
DMGN	C4384-G03-B		OUTLINE DRAWING
	20-016-1060-G1		

GPA-017
空中線部
ANTENNA
UNIT

GP-30
受信演算部
DISPLAY UNIT



1.0m φ5.3

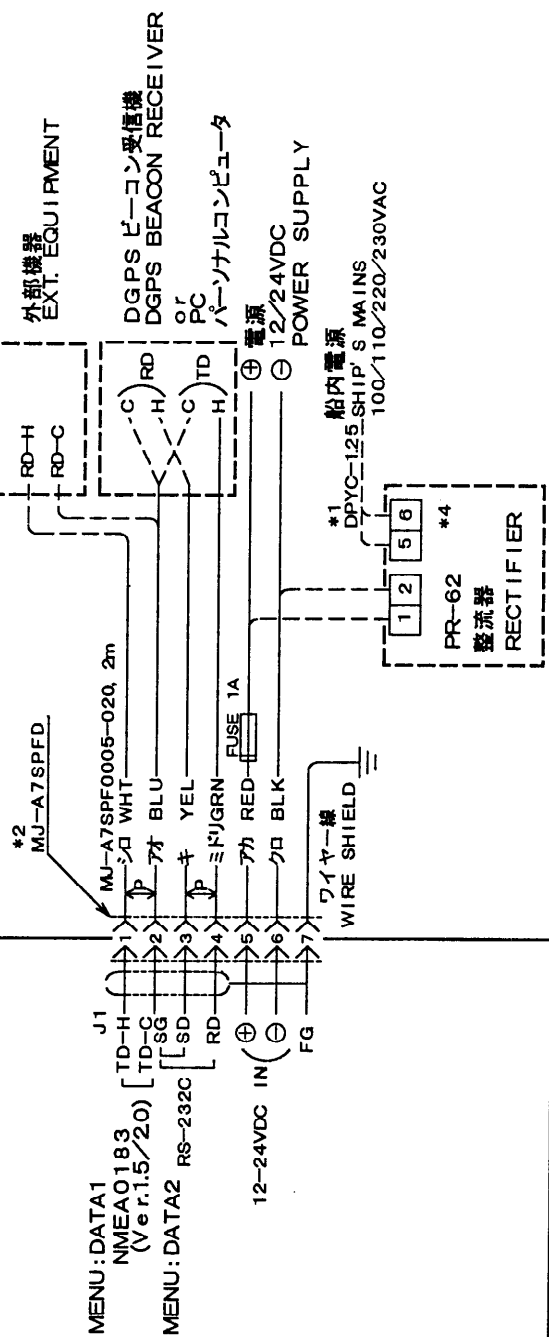

- 注記
- * 1 : 現地手配
 - * 2 : コネクタは工場取付済み
 - * 3 : メニューにより選択
 - * 4 : オプション
- NOTE
- * 1 : TO BE SUPPLIED LOCALLY.
 - * 2 : FACTORY-WIRED
 - * 3 : SELECTABLE ON MENU
 - * 4 : OPTIONAL SUPPLY.

DRAWN	Jan 8 '97 T. YAHASAKI	TITLE	GP-30
CHECKED	Jan 8 '97 K. KASUMIKI	名称	GPS 受信機
APPROVED	Jan 8 '97 T. Yamaguchi	相互結線図	
SCALE	1/100 MASS kg	NAME	GPS RECEIVER
DMGN	C4384-C01-D		INTERCONNECTION DIAGRAM

**GPA-018
空中線部
ANTENNA
UNIT**

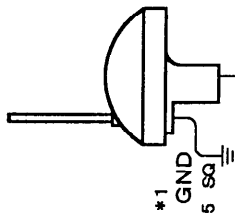

**GP-35
受信演算部
DISPLAY UNIT**

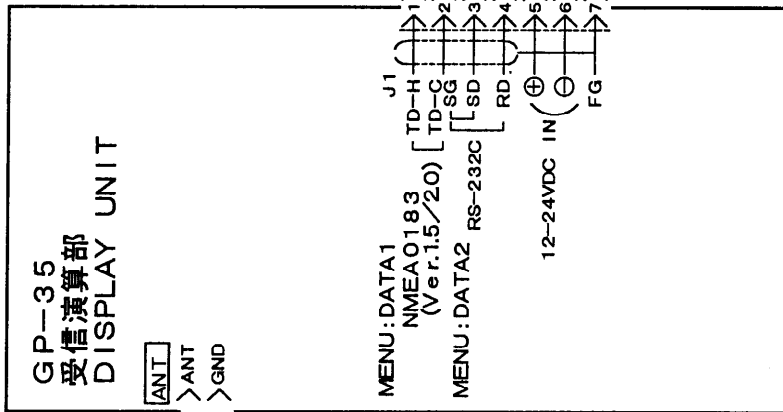
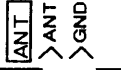

外部機器
例)
レーダー
魚群探知機
オートパイロット
リモートディスプレイ
水温計

EXT. EQUIPMENT
EX:

- RADAR
- ECHOSOUNDER
- AUTOPILOT
- REMOTE DISPLAY
- TEMP INDICATOR

注記

- * 1 : 現地手配
- * 2 : コネクターは工場取付済み
- * 3 : オプション
- * 4 : アップ・ダウンロード時DGPS測定不可。

NOTE

- * 1: TO BE SUPPLIED LOCALLY.
- * 2: FACTORY-WIRED
- * 3: OPTIONAL SUPPLY.
- * 4: DGPS NAVIGATION IS NOT AVAILABLE DURING UP/DOWN LOADING

DRAWN	Jan. 8 '97 T. Yamazaki	TITLE	GP-35
CHECKED	Jan. 8 '98 K. Kusumoto	名称	GPS 航法装置
APPROVED	Jan. 8 '98 H. Sawaguchi	相互結線図	
SCALE	1/100 MASS kg	NAME	GPS NAVIGATOR
DMC No	C4385-C01-B		INTERCONNECTION DIAGRAM

Free Manuals Download Website

<http://myh66.com>

<http://usermanuals.us>

<http://www.somanuals.com>

<http://www.4manuals.cc>

<http://www.manual-lib.com>

<http://www.404manual.com>

<http://www.luxmanual.com>

<http://aubethermostatmanual.com>

Golf course search by state

<http://golfingnear.com>

Email search by domain

<http://emailbydomain.com>

Auto manuals search

<http://auto.somanuals.com>

TV manuals search

<http://tv.somanuals.com>