

FURUNO

OPERATOR'S MANUAL

MARINE RADAR

MODEL MODEL 1621 MARK-2



FURUNO ELECTRIC CO., LTD.
NISHINOMIYA, JAPAN

©FURUNO ELECTRIC CO., LTD.

9-52, Ashihara-cho,
Nishinomiya, Japan 662

Telephone: 0798-65-2111
Telefax: 0798-65-4200

-Your Local Agent/Dealer

All rights reserved. Printed in Japan

FIRST EDITION : MAR 1996
C : NOV. 1, 1996

(TAYA)

PUB. No. OME-34280
MODEL1621 MARK-2





SAFETY INSTRUCTIONS

"DANGER", "WARNING" and "CAUTION" notices appear throughout this manual. It is the responsibility of the installer and operator of the equipment to read, understand and follow these notices. If you have any questions regarding these safety instructions, please contact a FURUNO agent or dealer.



DANGER

This notice indicates a potentially hazardous situation which, if not avoided, will result in death or serious injury.



WARNING

This notice indicates a potentially hazardous situation which, if not avoided, could result in death or serious injury.



CAUTION

This notice indicates a potentially hazardous situation which, if not avoided, could result in minor or moderate injury, or property damage.

WARNING



Do not open the equipment.

This equipment uses high voltage electricity which can shock, burn or cause serious injury. Only qualified personnel should work inside the equipment.



Wear a safety belt and hard hat when working on the antenna unit.

Serious injury or death can result if someone falls from the antenna mast.



Stay away from transmitting antenna.

The radar antenna emits microwave radiation which can be harmful to the human body, particularly the eyes. Never look directly into the antenna radiator from a distance of less than 1 m when the radar is in operation.

Keep heater away from equipment.

Heat can alter equipment shape and melt the power cord, which can cause fire or electrical shock.

Do not operate the unit with wet hands.

Electrical shock can result.

Do not disassemble or modify the equipment.

Fire, electrical shock or serious injury can result.

Turn off the power immediately if water leaks into the equipment, or the equipment is emitting smoke or fire.

Continued use of the equipment can cause fire or electrical shock.

CAUTION



Ground the equipment to prevent electrical shock and mutual interference.

Use the proper fuse.

Use of a wrong fuse can result in fire or permanent equipment damage.

Power the equipment with the proper power supply.

Powering the equipment with a wrong power supply can cause permanent equipment damage.

Do not use the equipment for other than its intended purpose.

Personal injury can result if the unit is used as a chair or stepping stool, for example.

Do not place objects on the top of the equipment.

The equipment can overheat, or personal injury can result if the object falls.

TABLE OF CONTENTS

FOREWORD	v
SPECIFICATIONS	vii
EQUIPMENT LISTS	ix
PRINCIPLE OF OPERATION	xi

Chapter 1 OPERATION

1.1 Control Description	1-1
1.2 Indications and Markers	1-2
1.3 Turning the Radar On/Off	1-2
1.4 Transmitting, Stand-by	1-3
1.5 LCD Tone and Brilliance	1-3
1.6 Selecting Range	1-3
1.7 Receiver Sensitivity	1-3
1.8 Suppressing Sea Clutter	1-4
1.9 Suppressing Rain Clutter	1-5
1.10 Range Rings	1-5
1.11 Cursor	1-5
1.12 Heading Marker	1-6
1.13 Menu Operation	1-6
1.14 Control Panel Illumination	1-6
1.15 Measuring the Range	1-7
1.16 Measuring the Bearing	1-7
1.17 Shifting the Display	1-8
1.18 Zoom	1-8
1.19 Echo Trails	1-8
1.20 Guard Alarm Zone	1-9
1.21 Interference Rejector	1-10
1.22 Echo Stretch	1-10
1.23 Watchman	1-11
1.24 Displaying Navigation Data	1-11
1.25 Displaying Navigation Data During Stand-by	1-12
1.26 Echo/Background Scheme	1-12
1.27 Selecting Ranges to Use	1-12
1.28 Description of Optional Equipment	1-13

Chapter 2 RADAR OBSERVATION

2.1 Radar Picture, Target Properties and Radar Pulse	2-1
2.2 Range Resolution	2-1
2.3 Bearing Resolution	2-2
2.4 False Echoes	2-2
2.5 Minimum and Maximum Ranges	2-3
2.6 Locating a Ship or Survival Craft in Distress by SART	2-4

Chapter 3 MAINTENANCE & TROUBLESHOOTING

3.1 Maintenance	3-1
3.2 Troubleshooting	3-2

Chapter 4 INSTALLATION

4.1 Antenna Unit Installation	4-1
4.2 Display Unit Installation	4-4
4.3 Connections	4-5
4.4 Installation Check	4-7
4.5 Adjustments	4-7
4.6 Adjustments for Technicians	4-9
4.7 Restoring Default Settings	4-10

OUTLINE DRAWINGS	D-1
SCHEMATIC DIAGRAMS	S-1

FOREWORD

A Word to FURUNO Model 1621 MARK-2 Owners

FURUNO Electric Company thanks you for purchasing the MODEL 1621 MARK-2 Marine Radar. We are confident you will discover why the FURUNO name has become synonymous with quality and reliability.

For over 40 years FURUNO Electric Company has enjoyed an enviable reputation for quality and reliability throughout the world. This dedication to excellence is furthered by our extensive global network of agents and dealers.

Your radar is designed and constructed to meet the rigorous demands of the marine environment. However, no machine can perform its intended function unless properly installed and maintained. Please carefully read and follow the installation, operation and maintenance procedures set forth in this manual.

We would appreciate feedback from you, the end-user, about whether we are achieving our purposes.

Thank you for considering and purchasing FURUNO.

Features

Your radar has a large variety of functions, all contained in a rugged plastic case. All controls respond immediately to the operator's command and each time a key is pressed the corresponding change can be seen on the screen.

The main features of the MODEL 1621 MARK-2 are

- Traditional FURUNO reliability and quality in a compact, lightweight and low-cost radar.
 - Compact and light-weight radome antenna with precision 34 cm center-fed radiator.
 - Stepping scanner motor.
 - High definition 6-inch rasterscan display.
 - Automatic control of sensitivity and STC for simplified operation.
 - Targets can be displayed in black on white background or vice versa, for optimal viewing under any lighting.
 - On-screen alphanumeric readout of all operational information.
 - Standard features include Display Shift, EBL, Echo Stretch, Echo Trail, Guard Alarm, Interference Rejector, VRM, Zoom.
 - Guard zone watches for targets entering (or exiting) a guard zone.
 - Operates on 12V or 24V DC power supply and consumes only 30 watts.
 - Position in latitude and longitude, speed, and range and bearing to a waypoint can be shown in the bottom text area with navigation data input in NMEA 0183 format.
 - Navigation data such as position, water temperature and depth can be shown during stand-by (requires optional sensors).
 - Display of NAVIONICS® charts with Chart Plotter RP-110L (option).
 - LCD equipped with temperature sensor which maintains viewability under temperature change.
- Daylight viewing radar specially designed for small craft and sailing yachts.

SPECIFICATIONS

ANTENNA UNIT

Radiator type	Parabola
Radiator length	34 cm
Horizontal beamwidth	6.2° typical
Vertical beamwidth	30° typical
Sidelobe	Less than -20 dB
Polarization	Horizontal
Antenna rotation speed	24 rpm
Wind load	Relative wind 100 kt
Radiation hazard	100 W/m ² : None 10 W/m ² : 0.75 m 1 W/m ² : 3.0 m
Waterproofing spec.	IEC IPX6
Drive motor power	12 VDC
Color	Cover: N9.5 (White) Base: 2.5PB3.5/10 (Blue)
Mass	5 kg

TRANSCEIVER MODULE (in radome)

Transmitting tube	Magnetron (E3587)
Freq. & modulation	9410 MHz ±30 MHz
Peak output power	2 kW nominal
Modulator	FET switching method
I. F.	60 MHz
Bandwidth	7 MHz (all ranges)
Mixer	MIC
Duplexer	Circulator with diode limiter

Noise figure 10 dB typical

Amplifier Linear

Pulse length & pulse repetition rate

Range (nm)	0.25, 0.5, 0.75	1, 1.5, 2	3, 4, 6, 8, 12, 16
Pulse-length	0.12 μs (short)	0.3 μs (med.)	0.8 μs (long)
Pulse rep. rate	2100 Hz Nominal	1200 Hz Nominal	600 Hz Nominal

DISPLAY UNIT

Indication system Rasterscan

Screen 6-inch diagonal yellow LCD panel

Range, range ring interval, no. of range rings

Range	Ring interval	No. of rings
0.25	0.125	2
0.5	0.25	4
0.75	0.25	3
1	0.5	4
1.5	0.5	3
2	0.5	4
3	1	3
4	1	4
6	2	3
8	2	4
12	3	4
16	4	4

Digitized video	Four levels
Range discrimination	25 m
Bearing accuracy	Within $\pm 1^\circ$
Range ring accuracy and discrimination	0.9% of range in use or 8 m, whichever is larger
Minimum range	37 m

Markers

Alarm zone, bearing scale, cursor, EBL, heading marker, range rings, VRM, waypoint (option)

Status indication

Guard Alarm (GUARD, G IN or G OUT, UP RANGE), Echo Stretch (ES), Echo Trail (TRAIL), Electronic Bearing Line (EBL), Interference Rejector (IR), Rain Clutter Rejection (FTC), Range, Range and Bearing to Cursor, Range Ring Interval, Stand-by (ST-BY), Variable Range Marker (VRM), Watchman (WATCHMAN), Zoomed Display (ZOOM)

Waterproofing std IEC IPX5

Color N3.0 2.5GY5/1.5 (Gray)

Mass 2 kg

GENERAL SPECIFICATIONS

Power supply & power consumption 12 V or 24 VDC, 30 W approx (8 W in Watchman mode)

Vibration

Vibration freq.	Total amplitude
5 to 12.5 Hz	± 1.6 mm
12.5 to 25 Hz	± 0.38 mm
25 to 50 Hz	± 0.1 mm

Environment

Antenna unit:
-25°C to +70°C
Display unit:
0°C to 60°C

Relative humidity
93 \pm 2% @ +40°C

Note: LCD contrast may be affected when ambient temperature is below 0°C (32°F) or above 50°C (122°F).

Safety features

Protection against reverse polarity, overvoltage, over-current and internal fault

Compass safe distance

Unit	Standard compass	Steering compass
Display	0.7 m	0.5 m
Antenna	2.0 m	1.5 m

SYSTEM CONFIGURATION

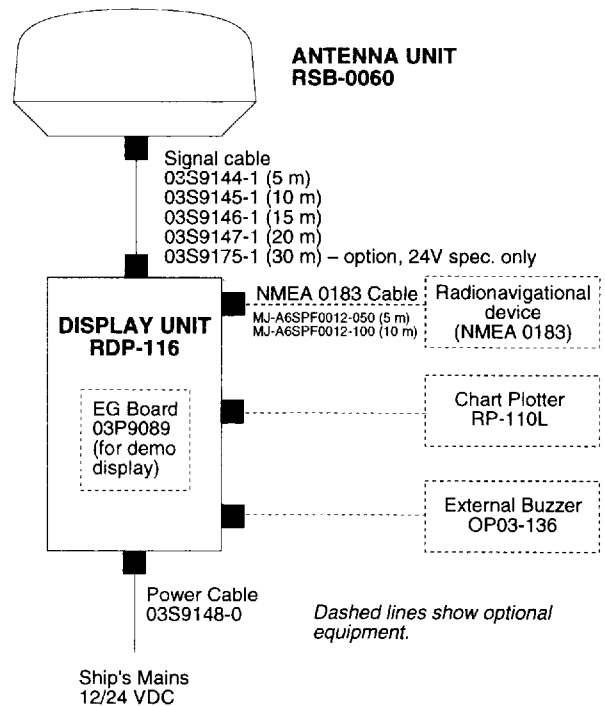

EQUIPMENT LISTS

Standard Supply

No.	Name	Type	Code No.	Qty	Remarks
1	Scanner unit	RSB-0060-050	000-086-748	1	
2	Display unit	RDP-116-S	000-086-750	1	
3	Installation materials (select one)	CP03-16500	000-086-761	1 set	Signal cable not supplied
		CP03-16510	000-086-762		5m signal cable assy
		CP03-16520	000-086-763		10m signal cable assy
		CP03-16530	000-086-764		15m signal cable assy
		CP03-16540	000-086-765		20m signal cable assy
4	Spare parts	SP03-09800	000-085-441	1 set	

Installation materials (except signal cable) and spare parts contained in a vinyl bag.

Installation Materials

No.	Name	Type	Code No.	Qty	Remarks
1	Signal cable			None	Select one. Connector fitted at both ends.
	Signal cable assy (5 m)	03S9144	000-129-608	1	
	Signal cable assy (10 m)	03S9145	000-129-609		
	Signal cable assy (15 m)	03S9146	000-129-611		
	Signal cable assy (20 m)	03S9147	000-129-612		
2	Power cable assy	03S9148	000-129-613	1	Connector fitted, w/fuse, 3.5 m
3	Tapping screw	5x20, SUS304	000-802-081	4	For fixing display unit
4	Hex. bolt	M10x25, SUS304	000-862-308	4	For fixing antenna unit
5	Blind film (K)	03-118-1103-0	100-185-380	1 set	To cover unused knob bolt hole

Spare Parts

No.	Name	Type	Code No.	Qty	Remarks
1	Fuse	FGBO-A 5A 125 VAC	000-549-064	2	For display unit

Optional Equipment

No.	Name	Type	Code No.	Qty	Remarks
1	NMEA Cable assy	MJ-A6SPF0012- 050	000-134-424	1	W/connectors, 5 m
		MJ-A6SPF0012- 100	000-133-817		W/connectors, 10 m
2	Signal cable assy. (30m)	03S9175	000-130-034	1	W/connector, For 24 VDC spec.
3	Mounting bracket	OP03-93	008-445-080	1	For mounting antenna unit on sailboat mast
4	EG Board kit	OP03-89	008-440-890	1	P. C. Board 03P9089 for demo display
5	External buzzer	OP03-136	000-086-443	1	
6	Chart plotter	RP-110L	000-002-073	1	

PRINCIPLE OF OPERATION

What is Radar?

The term RADAR is an acronym meaning RAdio Detection and Ranging. It is a device which measures the time it takes for a pulsed signal to be reflected back from an object.

How Ships Determined Position Before Radar

The use of echoes to determine position did not begin with radar. Ships would sound a short blast on their whistles, fire a shot, or strike a bell as an aid to navigation when running in fog near a rugged shoreline. The time between the origination of the sound and the returning of the echo indicated how far the ship was from the cliffs or the shore. The direction from which the echo was heard indicated the relative bearing of the shore.

How Radar Determines Range

Radar determines the range to the target by calculating the time difference between the transmission of a radar signal and the reception of the reflected echo. It is a known fact that radar waves travel at a nearly constant speed of 162,000 nautical miles per second. Therefore the time required for a transmitted signal to travel to the target and return as an echo to the source is a measure of the range to the target. Note that the echo makes a complete round trip, but only half the time of travel is needed to determine the one-way range to the target. This radar automatically takes this into account in making the range calculation.

How Radar Determines Bearing

The bearing to a target found by the radar is determined by the direction in which the radar antenna is pointing when it emits an electronic pulse and then receives a returning echo. Each time the antenna rotates pulses are transmitted in the full 360 degree circle, each pulse at a slightly different bearing from the previous one. Therefore, if one knows the direction in which the signal is sent out, one knows the direction from which the echo must return.

Radar Wave Speed and Antenna Rotation Speed

The speed of the radar waves out to the target and back again as echoes is extremely fast compared to the speed of rotation of the antenna. By the time radar echoes have returned to the antenna, the amount of antenna rotation after initial transmission of the radar pulse is extremely small.

The Radar Display

Targets are displayed on what is called a Plane Position Indicator (PPI). This display is essentially a polar diagram, with the transmitting ship's position at the center. Images of target echoes are received and displayed at their relative bearings, and at their distance from the PPI center.

With a continuous display of the images of targets, the motion of targets is also displayed.

See the figure on the next page for a comparison of actual situation and radar picture.

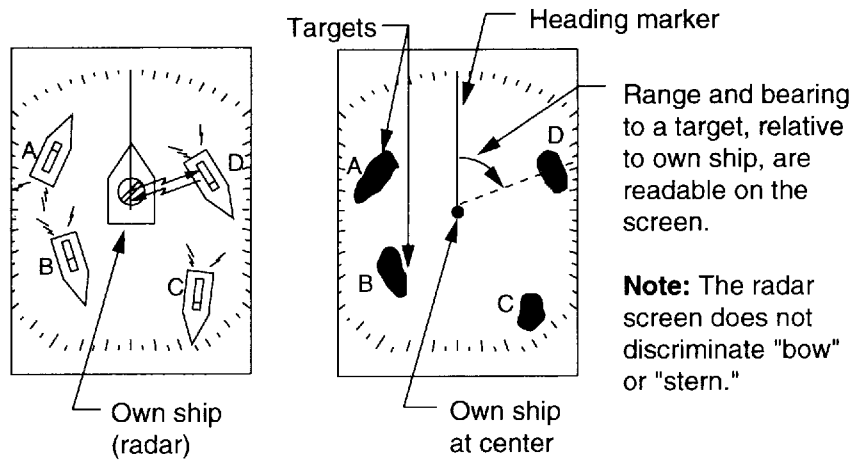

(A) Bird's eye view of situation

(B) Radar picture of (A)

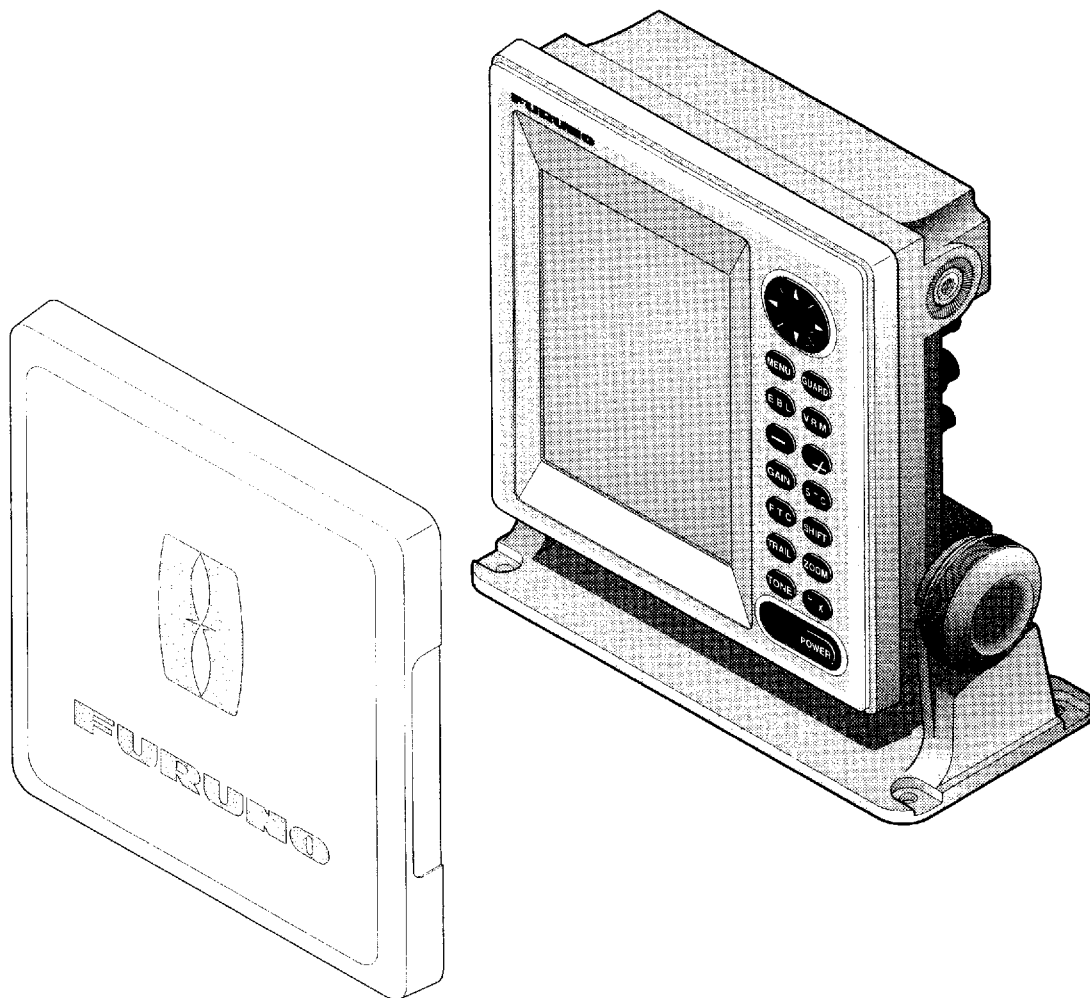

MODEL 1621 MARK-2 Display Unit

Chapter 1 OPERATION

1.1 Control Description

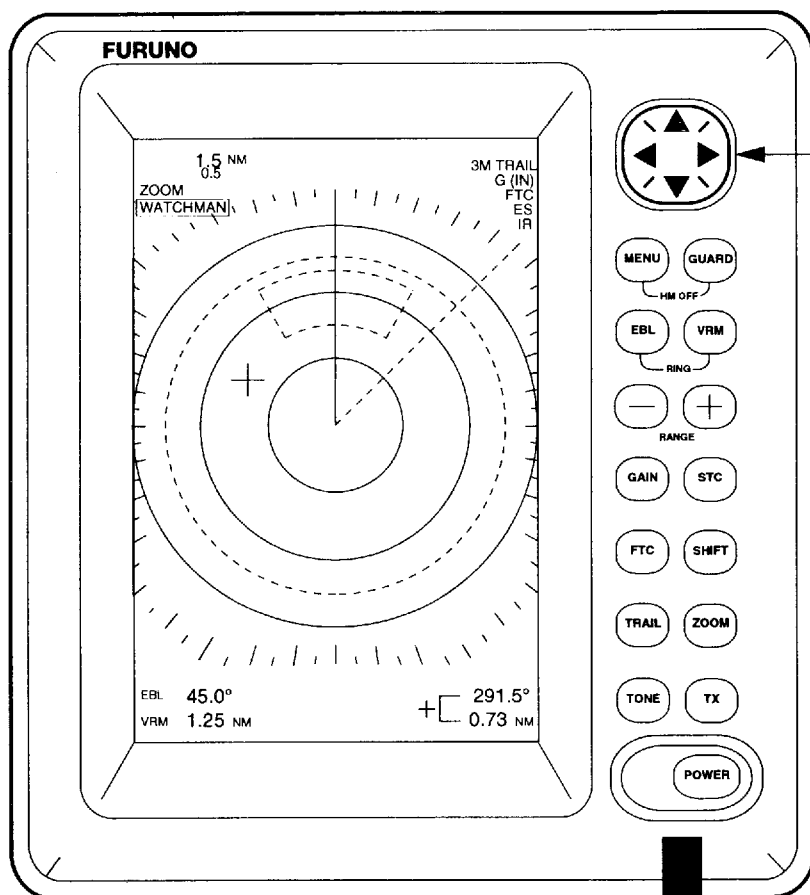

TrackDisk
Shifts EBL, VRM;
selects items on menus.

For description of indications and markers, see the figure at the top of the next page.

Figure 1-1 Display unit and control description

Control	Function	Control	Function
MENU	Opens/closes menu.	GUARD	Activates/disables guard zone. Press with [MENU] to temporarily erase heading marker.
EBL	Turns EBL on/off.	VRM	Turns VRM on/off. Press with [EBL] to turn range rings on/off.
—	Decreases range.	+	Increases range.
GAIN	Adjusts sensitivity.	STC	Suppresses sea clutter.
FTC	Suppresses rain clutter.	SHIFT	Shifts the display.
TRAIL	Target trails on/off.	ZOOM	Turns zoom feature on/off.
TONE	Adjusts LCD tone and brilliance.	TX	Toggles between TRANSMIT and ST-BY.
		POWER	Turns the system on/off.

1.2 Indications and Markers

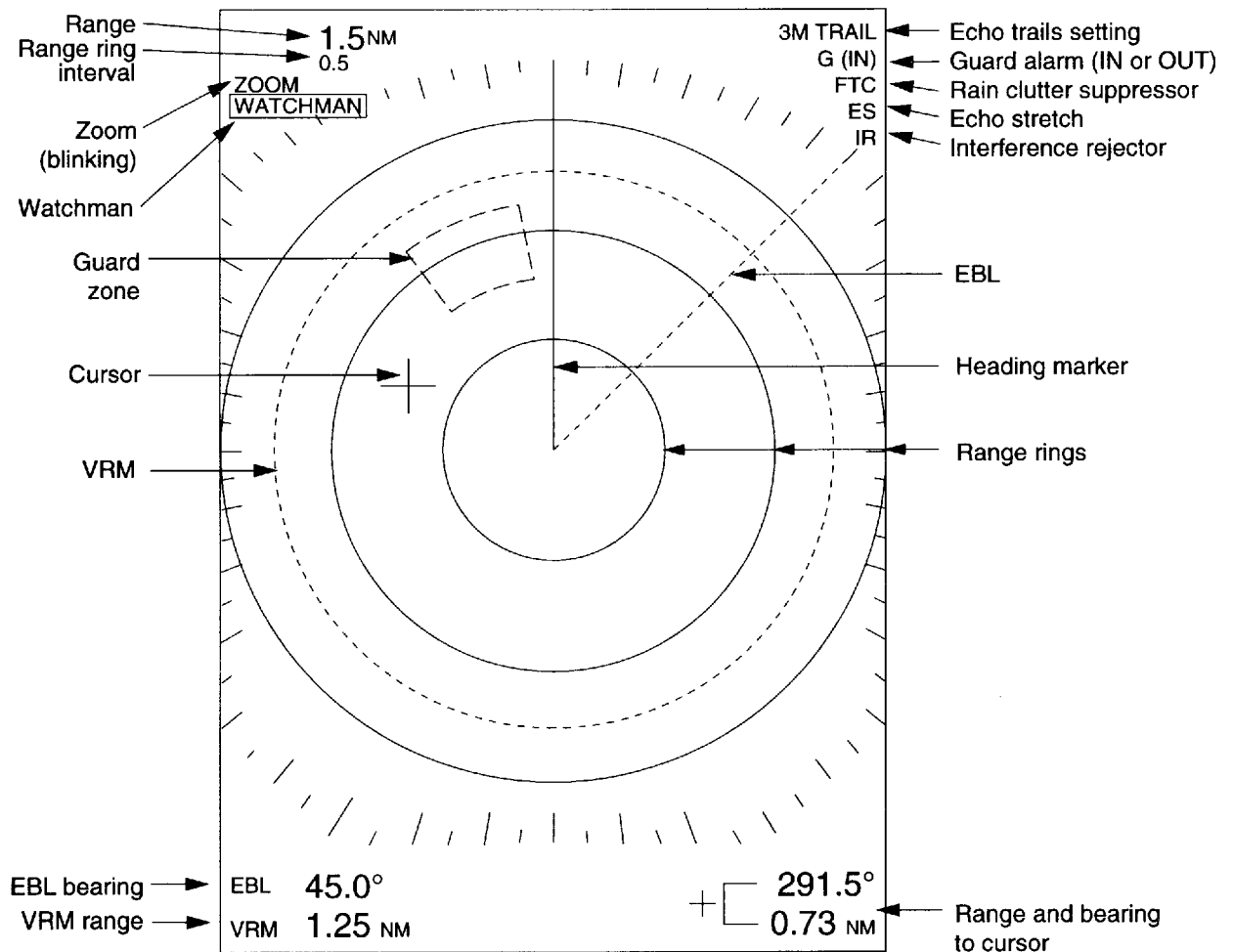

Figure 1-2 Indications and Markers

1.3 Turning the Radar On/Off

The [POWER] key turns the radar on/off. When turning on the power, the control panel lights and the timer displays the time remaining for warm up of the magnetron (device which transmits radar pulses), counting down from 1:30 to 0:00.



WARNING

The radar antenna emits microwave radiation which can be harmful to the human body, particularly the eyes. Never look directly into the antenna radiator from a distance of less than 1 m when the radar is in operation.

⚠ Quick Start

Provided that the radar was once in use with the transmitter tube (magnetron) still warm, you can turn on the radar into TRANSMIT status without the one-minute 30 second stand-by. If the power switch has been turned off by mistake and you want to restart the radar promptly do the following:

1. Press the [POWER] key not later than five seconds after power-off.
2. Press the [TX] key. The radar is restored for full operation.

1.4 Transmitting, Stand-by

After the power is turned on and the magnetron has warmed up, ST-BY (Stand-By) appears at the screen center, indicating the radar is ready to transmit radar pulses.

Press the [TX] key to transmit. Echoes appear in four levels of digitized video according to echo strength. Note that when a target is beneath a marker (VRM, EBL, heading marker, range ring) the part of the marker where the target lies is displayed in reverse video.

When you won't be using the radar for an extended period, but you want to keep it in a state of readiness, press the [TX] key to set the radar in stand-by.

Loss of bearing or heading signal

When there is no bearing or heading signal input from the antenna, BP-SIG-MISS or HDG-SIG-MISS appears on the display. If one of these indications appear, make sure the signal cable is securely tightened.

1.5 LCD Tone and Brilliance

1. Press the [TONE] key. The dialogue shown in Figure 1-3 appears.

TONE: 12

LOW ◀ ▶ HIGH

BRILL: 3

LOW ▼ ▲ HIGH

Figure 1-3 Dialogue for adjustment of LCD tone and brilliance

2. Press ◀/▶ or the [TONE] key to adjust tone; ▲/▼ to adjust brilliance.

The dialogue for adjustment of tone and brilliance is automatically erased when there is no TrackDisk operation for about 10 seconds. To erase it more quickly, press the [TONE] key after making the adjustment.

1.6 Selecting Range

The range selected automatically determines the range ring interval, the number of range rings and pulse repetition rate.

Press the [+] or [-] key to select a range. The range and range ring interval appear at the top left corner on the screen.

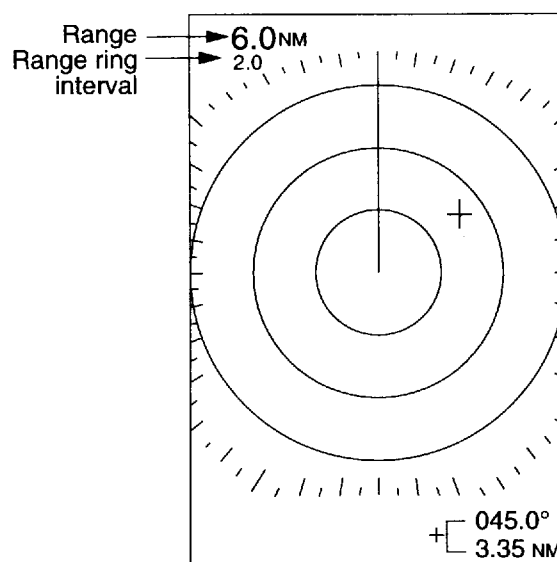

Figure 1-4 Location of range and range ring interval indications

1.7 Receiver Sensitivity

The [GAIN] key adjusts the sensitivity of the receiver. It works in precisely the same manner as the volume control of a broadcast receiver, amplifying the signals received.

You can adjust the sensitivity manually, or let the unit do it automatically. In either case, the proper setting is such that the background noise is just visible on the screen. Adjust the sensitivity on the highest range – the background noise is clearer on that range.

If you set up for too little sensitivity, weak echoes may be missed. On the other hand excessive sensitivity yields too much background noise; strong targets may be missed because of the poor contrast between desired echoes and the background noise on the display.

Automatic adjustment of sensitivity

1. Press the [GAIN] key to display the screen shown in Figure 1-5.

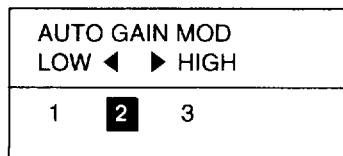

Figure 1-5 Dialogue for automatic adjustment of gain

2. Press ◀/▶ to set level desired: 1, Low; 2, Normal; 3, High.

Manual adjustment of sensitivity

1. Transmit the radar on long range.
2. Press the [GAIN] key to display the screen shown in Figure 1-6.

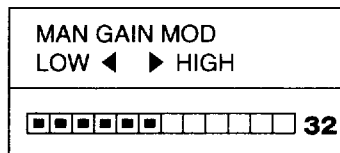

Figure 1-6 Dialogue for manual adjustment of gain

3. Press ◀/▶ to set level desired. 60 levels are available.

Note: The dialogues for adjusting sensitivity are automatically erased when there is no TrackDisk operation for 10 seconds. To erase them quicker, press the [GAIN] key after completing the setting.

1.8 Suppressing Sea Clutter

In rough weather, returns from the sea surface are received over several miles around own ship and mask nearby targets. This situation can be improved by properly using the [STC] key.

If the setting is too low, targets will be hidden in the clutter, while if it is set too high, both sea clutter and targets will disappear from the display. In most cases adjust the key until clutter has disappeared to leeward, but a little is still visible windward.

A common mistake is too over-adjust the [STC] key so that the surface clutter is completely removed. By setting up for maximum STC effect, you will see how dangerous this can be; a dark zone will be created near the center of the screen, causing a loss of close-in targets. This dark zone is even more dangerous if the sensitivity has not been properly adjusted. Always leave a little surface clutter visible on the screen. If no clutter is observed (on very calm waters), turn off the circuit.

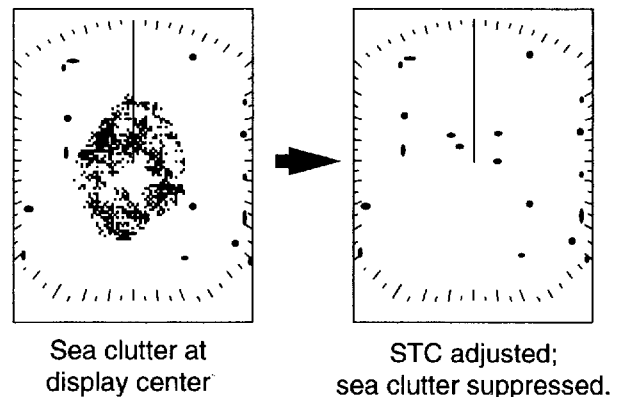

Figure 1-7 Effect of STC

Automatic Sea Clutter Control

1. Press the [STC] key to show the dialogue shown in Figure 1-8.

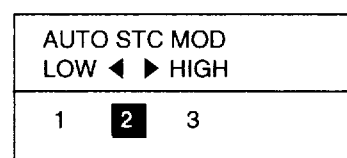



Figure 1-8 Dialogue for automatic adjustment of STC

- Press ◀/▶ to set level desired: 1, Low; 2, Normal; 3, High.

 CAUTION
The auto STC function can erase weak targets.

Manual adjustment of Sea Clutter Control

- Press the [STC] key to display the dialogue shown in Figure 1-9.

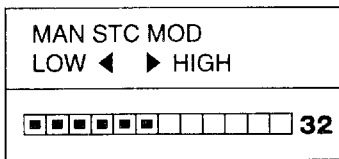

Figure 1-9 Dialogue for manual adjustment of STC

- Press ◀/▶ to set level desired. 60 levels are available.

Note: The dialogues for adjusting STC are automatically erased when there is no TrackDisk operation for 10 seconds. To erase them quicker, press the [STC] key after completing the setting.

1.9 Suppressing Rain Clutter

In adverse weather, clouds, rain or snow produce spray-like spurious echoes which impair target detection over a long distance. These echoes can be suppressed by turning on the [FTC] key.

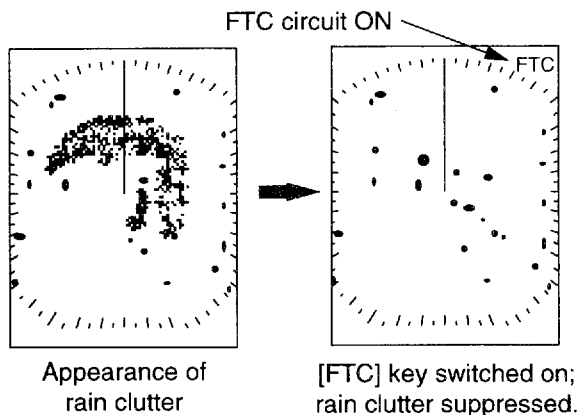

Figure 1-10 Effect of the [FTC] key

1.10 Range Rings

The range rings are the concentric circles around own ship and they provide an estimated of target range. The number of rings is automatically determined by the selected range scale and their interval is displayed at the upper-left corner on the screen.

To turn the range rings on or off, press the [EBL] and [VRM] keys together.

1.11 Cursor

The cursor is always displayed and functions to measure the range and bearing to a target. Operate the TrackDisk to place the cursor on the inside edge of the target for range or center of the target for bearing. The range and bearing to the cursor appear at the bottom right corner on the display.

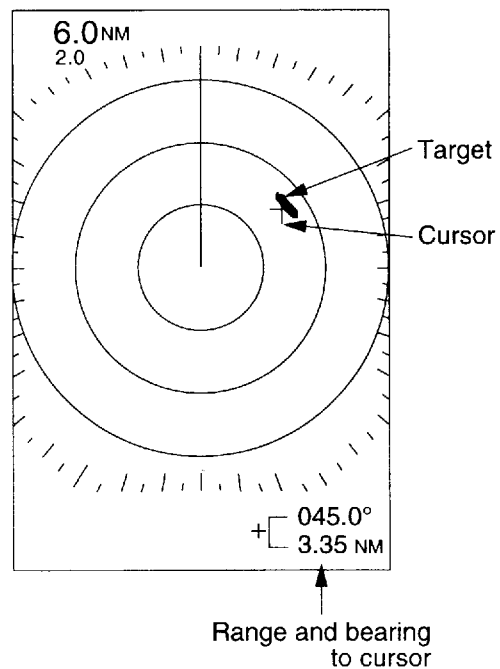

Figure 1-11 How to measure range and bearing by the cursor

1.12 Heading Marker

The heading marker indicates the ship's heading and it is the solid line which appears at zero degrees on the bearing scale.

To temporarily erase the heading marker to look at targets existing dead ahead of own ship, press the [MENU] and [GUARD] keys together. Release the keys to display the marker again.

1.13 Menu Operation

The menu contains ten functions which normally do not require frequent adjustment in everyday operation.

Basic menu operation

1. Press the [MENU] key to display the menu.

PRESS ▲/▼ TO SELECT MENU ITEM, ◀/▶ TO CHANGE SETTING.		
1	ECHO STRETCH	ON OFF
2	INT. REJECT	ON OFF
3	NAV DATA	ON OFF
4	VIDEO	RVS NOM
5	WATCHMAN	OFF 5M 10M 20M
6	DIMMER	0 1 2 3

Press ▼/▲ at page boundaries to switch between menus.

PRESS ▲/▼ TO SELECT MENU ITEM, ◀/▶ TO CHANGE SETTING.		
7	DSPL ON STBY	NAV OFF
8	TRAIL TIME	CONT 30S 1M 3M 6M
9	TRAIL BRILL	LOW HIGH
10	RANGE (NM)	1/4 1/2 3/4 1 1.5 2 3 4 6 8 12 16

Default settings in highlight.

Figure 1-12 Menus

2. Press ▲/▼ to select item.
3. Press ◀/▶ to select option.
4. Press the [MENU] key to register option and close the menu.

Menu description

Table 1-1 Menu description

Menu item	Description
1 ECHO STRETCH	Stretches echoes in range direction.
2 INT. REJECT	Suppresses radar interference.
3 NAV DATA	Turns navigation data display on/off.
4 VIDEO	Selects echo/background scheme.
5 WATCHMAN	Selects transmitting interval.
6 DIMMER	Adjusts control panel illumination.
7 DSPL ON STBY	Turns navigation data display in stand-by on/off.
8 TRAIL TIME	Selects trail time (plotting interval).
9 TRAIL BRILL	Selects echo trail brilliance.
10 RANGE	Selects ranges to use.

1.14 Control Panel Illumination

1. Press the [MENU] key.
2. Select DIMMER.
3. Select level desired; 3 is the highest level of illumination.
4. Press the [MENU] key.

1.15 Measuring the Range

The bearing to a target can be measured by the range rings, by the cursor and by the VRM (Variable Range Marker).

Measuring range by the range rings

Count the number of rings between the center of the display and the target. Check the range ring interval and judge the distance of the echo from the inner edge of the nearest ring.

Measuring range by VRM

1. Press the [VRM] key to turn on the VRM.
2. Within 10 seconds after turning on the VRM; that is, while "VRM" is highlighted, press ▲/▼ to place the VRM on the inside edge of the target.
3. Check the VRM readout at the bottom left corner on the screen.

Note: The VRM is "frozen" on the display when the [VRM] key is pressed a second time, or 10 seconds elapses without pressing ▲/▼. When the VRM is fixed on the screen "VRM" is not highlighted.

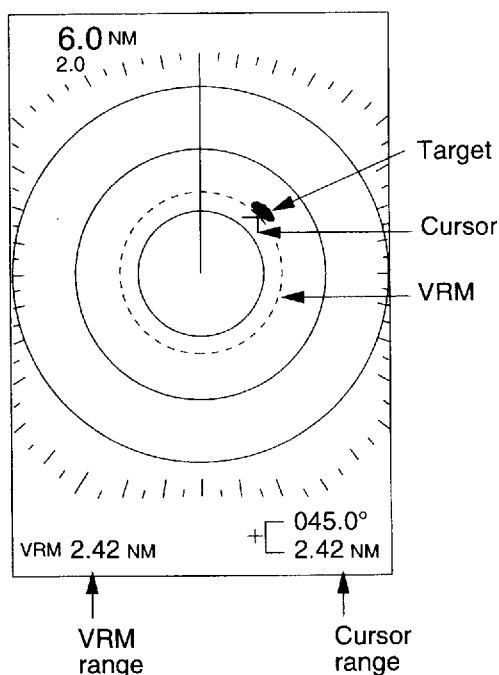

Figure 1-13 How to measure range by the cursor and VRM

1.16 Measuring the Bearing

The bearing to a target can be measured by using the cursor or the EBL.

Measuring bearing by the EBL

1. Press the [EBL] key to turn on the EBL.
2. Within 10 seconds after turning on the EBL; that is, while "EBL" is highlighted, press ◀/▶ to bisect the target with EBL.
3. Check the EBL readout at the bottom left corner on the screen.

Note: The EBL is "frozen" on the screen when the [EBL] key is pressed a second time, or 10 seconds elapses without pressing ◀/▶. When the EBL is fixed on the screen "EBL" is not highlighted.

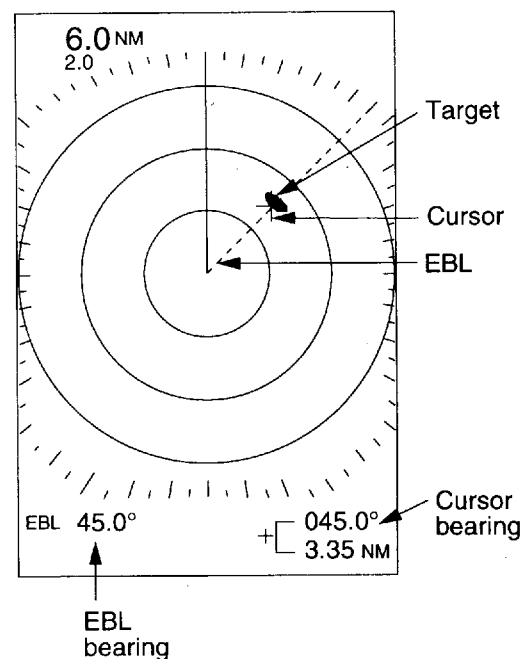

Figure 1-14 Measuring bearing by the cursor and the EBL

Checking for collision course by EBL

You can use the EBL to determine if a radar target may be on a collision course with your boat. Measure the bearing to the target with the EBL. If the target tracks along the EBL as it approaches the screen center it may be on a collision course with your boat.

1.17 Shifting the Display

Your vessel's position can be shifted backward by 1/3 of the range to increase the forward range without changing the range or size of targets.

Press the [SHIFT] key to turn the shifted display on/off.

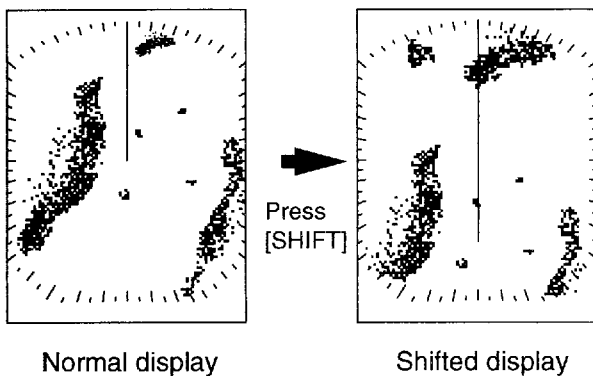

Figure 1-15 Shifting the display

1.18 Zoom

The zoom feature allows you to double the size of the area between your vessel and any location within the current range to take a closer look at an area of interest.

1. Select location with the cursor.
2. Press the [ZOOM] key.

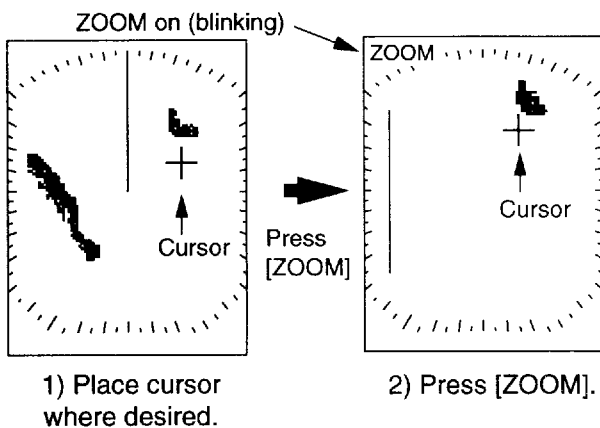

Figure 1-16 Zoom function

Note: The zoom feature is inoperative when the display is shifted.

1.19 Echo Trails

Echo trails are simulated afterglow of target echoes that represent their movements relative to own ship.

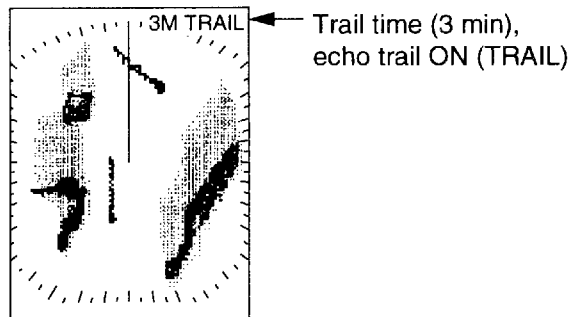

Figure 1-17 Echo trails

Starting echo trail

Press the [TRAIL] key to start the echo trail function. "TRAIL" and the echo trail time selected appear at the top right corner on the screen. Then, afterglow starts extending from all targets.

Canceling echo trail

Press the [TRAIL] key to erase echo trails and echo trail indications.

Trail time

1. Press the [MENU] key.
2. Select TRAIL TIME (page 2).
3. Select echo trail time desired; continuous, 30 seconds, 1, 3 or 6 min.
4. Press the [MENU] key.

Trail brilliance

1. Press the [MENU] key.
2. Select TRAIL BRILL (page 2).
3. Select HIGH or LOW
4. Press the [MENU] key.

1.20 Guard Alarm Zone

The guard alarm allows the operator to set the desired range and bearing for a guard zone. When ships, islands, landmasses, etc. violate the guard zone an audible alarm sounds to call the operator's attention. The alarm will sound on targets entering or exiting the zone depending on zone status after setting the alarm.

 CAUTION
<ul style="list-style-type: none"> • The alarm should not be relied upon as the sole means for detecting possible collision situations. • STC, FTC and GAIN controls should be properly adjusted to be sure the alarm system does not overlook target echoes.

How guard zone type is determined

After the guard zone is set, the radar starts searching for targets inside the guard zone for about 8 to 12 seconds. When it finishes searching it displays the results at the top right corner on the screen as follows:

G (IN): When no target exists in the zone, "G (IN)" appears. The audible alarm sounds to targets which enter the guard zone.

G (OUT): When there are targets in the guard zone, the screen shows "G (OUT)". The audible alarm sounds on all targets which exist in the guard zone or targets within the guard zone.

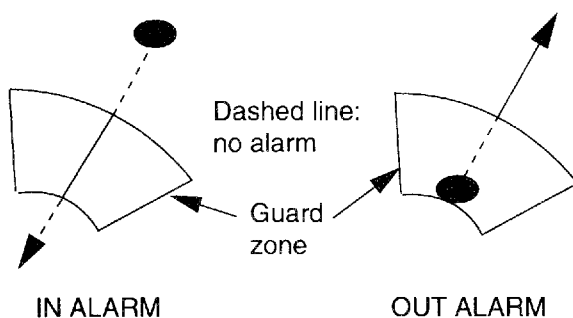

Figure 1-18 In and out alarms

Setting a guard zone

1. Operate the TrackDisk to place the cursor at the top left corner of the zone and press [GUARD].
2. Operate the TrackDisk to place the cursor at the bottom right corner of the zone and press [GUARD].

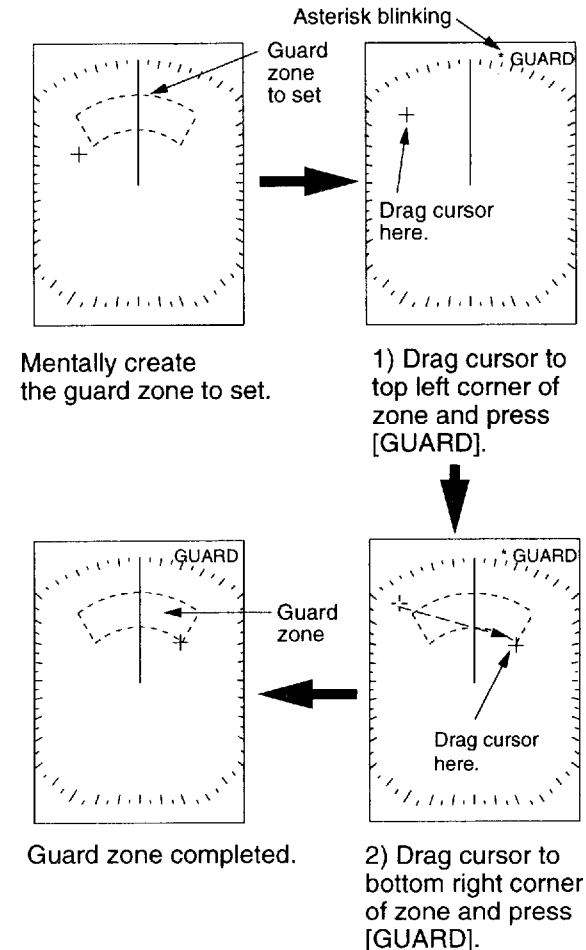

Figure 1-19 How to set a guard zone

Note: When the radar range is less than one half of the guard zone range, the guard zone disappears and the indication "UP RNG" replaces G (IN) or G (OUT). If this happens, raise the range to re-display the guard zone.

Silencing the audible alarm

When a target violates the guard zone, the target flashes and the audible alarm sounds. You can silence the audible alarm by pressing the [GUARD] key. When this is done, GUARD, displayed in reverse video, replaces G (IN) or

G (OUT) and the guard zone is displayed in reverse video. This means the audible alarm is temporarily deactivated. Press the key again to reactivate the alarm.

Canceling the guard zone and guard alarm

Press and hold down the [GUARD] key to erase the guard zone.

1.21 Interference Rejector

Mutual radar interference may occur in the vicinity of another shipborne radar operating in the same frequency band (9 GHz). It is seen on the screen as a number of bright spikes either in irregular patterns or in the form of usually curved spoke-like dotted lines extending from the center to the edge of the picture. This type of interference can be reduced by activating the interference rejector circuit. "IR" appears at the top right corner when the interference rejector circuit is on.

1. Press the [MENU] key.
2. Select INT REJECT.
3. Select ON or OFF.
4. Press the [MENU] key.

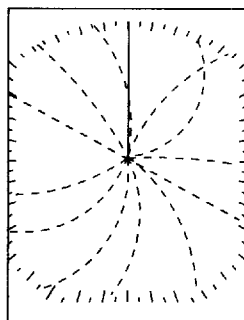

Figure 1-20 Radar interference

1.22 Echo Stretch

On long ranges target echoes tend to shrink in the range direction, making them difficult to see. On short and medium ranges such as 1.5, 3 and 6 nm range scales, the same sized targets get smaller on screen as they approach own ship. This is due to the inherent property of the radiation pattern produced by the antenna. To enhance target video, use the echo stretch feature.

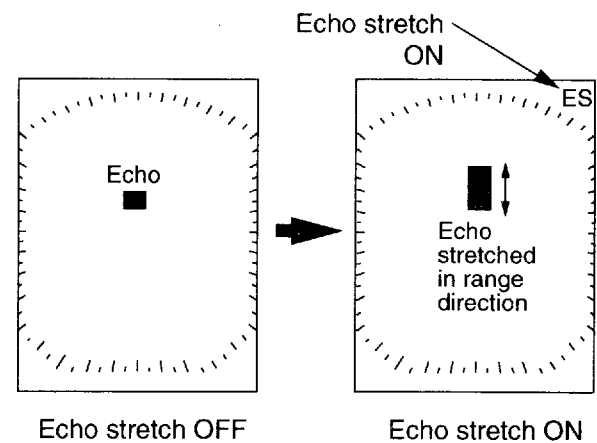

Figure 1-21 Echo stretch

1. Press the [MENU] key.
2. Select ECHO STRETCH.
3. Select ON or OFF.
4. Press the [MENU] key.

ES appears at the top right corner on the screen when the echo stretch feature is on.

Note 1: Echo stretch magnifies not only small target pips but also returns from sea surface, rain and radar interference. For this reason, make sure that these types of interference have been sufficiently suppressed before activating the echo stretch feature.

Note 2: Echo stretch feature is not available on the ranges between 0.25 and 0.75 nautical miles.

1.23 Watchman

The watchman function periodically transmits the radar for about thirty seconds to check for targets in a guard zone. If it finds change in the zone from the previous transmission it sounds the audible alarm, cancels the watchman function and transmits the radar continuously. This feature is useful when you do not need to observe the radar continuously but want to be alerted to radar targets in a specific area, namely, the guard zone.

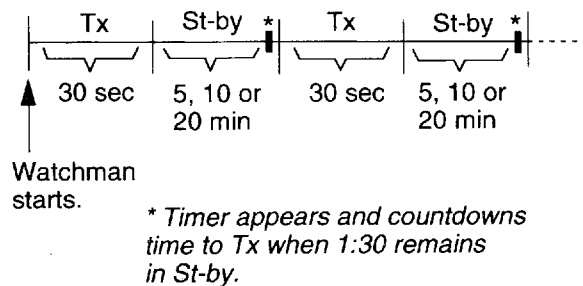

Figure 1-22 How watchman works

Turning on watchman

1. Press the [MENU] key.
2. Select WATCHMAN.
3. Select transmitting interval.
4. Press the [MENU] key.

WATCHMAN appears at the top left corner on the screen when the watchman function is on.

CAUTION

Watchman should not be relied upon as the sole means for detecting possible collision situations. Always maintain a vigilant watch.

Cancelling watchman

Press any key while the radar is transmitting.

1.24 Displaying Navigation Data

With navigation data input in NMEA 0183 format, navigation data can be displayed at the screen bottom.

Navigation data includes position, course, speed, and range and bearing to destination waypoint (if set on navaid). Waypoint is shown on the screen by a dashed ring which is connected to the screen center (own position) by a dashed line.

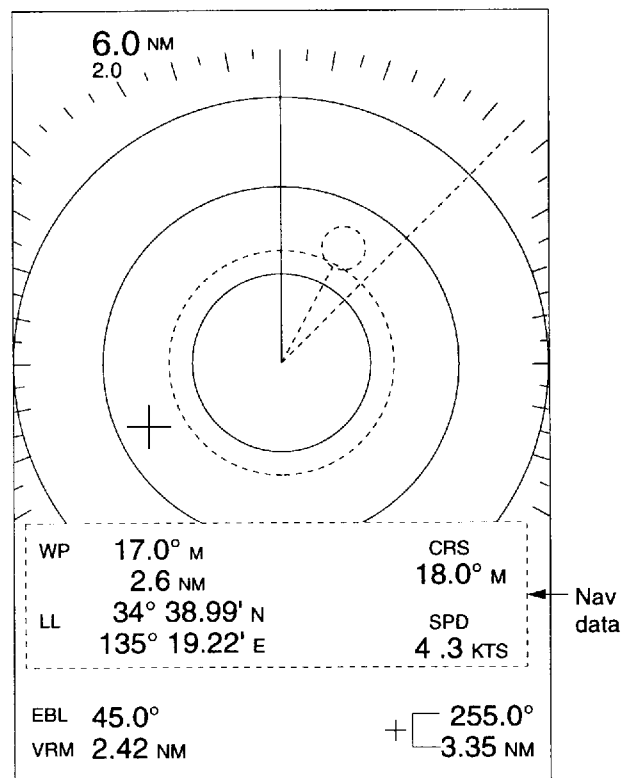

Figure 1-23 Sample navigation data display

Turning on the navigation data display

1. Press the [MENU] key.
2. Select NAV DATA.
3. Select ON.
4. Press the [MENU] key.

1.25 Displaying Navigation Data During Stand-by

Navigation data may be displayed during stand-by (requires external sensors) as follows:

1. Press the [MENU] key.
2. Select DSPL ON STBY.
3. Select NAV.
4. Press the [MENU] key

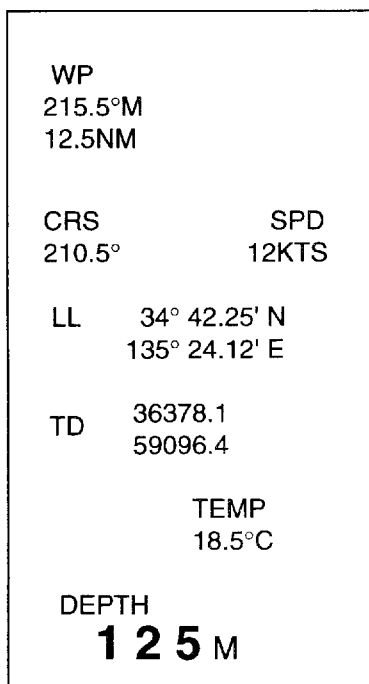
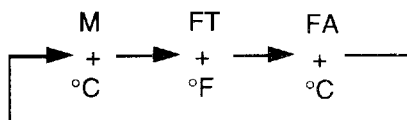

Figure 1-24 Sample navigation data screen shown during stand-by

Unit of measurement for depth and temperature

The unit of measurement for depth and water temperature (external sensor required) can be selected with the [EBL] key. Each pressing of the [EBL] key changes the units of measurement in the sequence shown in the figure below.



Note 1: A location is blank when there is no corresponding data.

Note 2: To receive data from multiple equipment, all data must be combined into one data line by using a data mixing device.

1.26 Echo/Background Scheme

The default echo/background scheme is black echoes on white background. However, you may reverse this scheme as follows:

1. Press the [MENU] key.
2. Select VIDEO.
3. Select RVS.
4. Press the [MENU] key.

1.27 Selecting Ranges to Use

This radar has 12 ranges, some you may not require. You can select the ranges to use as follows:

1. Press the [MENU] key.
2. Select RANGE (page 2).
3. Select range to use and press the [EBL] key.
4. Press the [MENU] key.

1.28 Description of Optional Equipment

Chart plotter RP-110L

The RP-110L is an add-on chart drive for this radar enabling the display of NAVIONICS® charts. Connected with radionavigational equipment such as GPS, the RP-110L plots ship's track, intended course and waypoints on an electronic chart.

External buzzer

The external buzzer sounds the guard alarm at a remote location.

Radionavigational equipment

A radionavigational equipment which outputs data in NMEA 0183 format can be connected to this radar, and navigation data can be seen in the bottom text area.

Demonstration display

This radar can function as a demonstration radar, displaying internally generated artificial radar echoes. The artificial echoes, which realistically depict a radar picture of a harbor, can be processed by most of the radar controls. This function requires the EG (ECHO GENERATOR) Board.

Chapter 2 RADAR OBSERVATION

2.1 Radar Picture, Target Properties and Radar Pulse

Strength of reflection

The strength of the reflected echo depends not only on the height and size of the target but also its shape, material and the angle at which the radio pulse strikes it.

Target size and strength of reflected echo

The size of a target has little to do with the strength of the reflected echo. If the radio pulse strikes the target at a right angle, even a small target will return a strong echo, provided its material is a good radar target.

Radar picture and how the pulse strikes a target

A return echo will be weak if the angle at which a radio pulse strikes a target is small. For example, flat surfaces, such as sandy beaches, sandbars and mudbanks have almost no area that can reflect energy back to the radar. Conical surfaces, such as a lighthouse, generate a weak return echo because their shape diffuses most of the radiated energy.

Radar sees only the near side of targets. For example, it cannot show you what is behind a sea wall or an island. The echo of a mountain peak may appear on the radar as a peninsula or small island.

Target material and reflected echo

Generally, steel objects return a very strong echo, and reefs and water return a weak echo. The weakest echoes come from wood and fiberglass objects. In summary, non-metallic objects and flat or conical objects are not good radar targets.

Actual topography and radar picture

The radar cannot display topography in its actual shape.

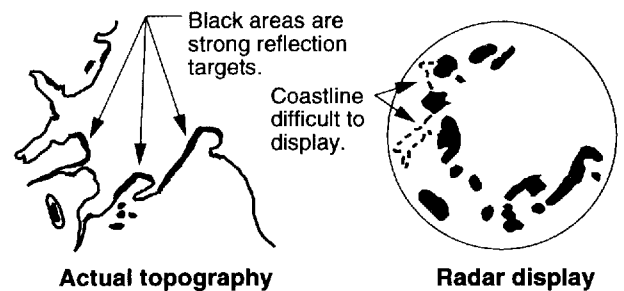

Figure 2-1 Radar picture and corresponding topography

2.2 Range Resolution

Range resolution is a measure of the capability of a radar to display as separate pips the echoes received from two targets which are on the same bearing and are close together.

The main factor which affects range resolution is pulselength. Two targets on the same bearing, close together, cannot be seen as two distinct echoes on the display unless they are separated by a distance greater than one-half the pulselength.

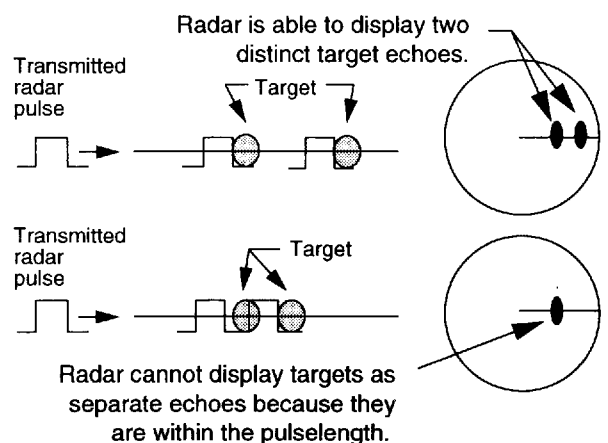

Figure 2-2 Range resolution

2.3 Bearing Resolution

Bearing resolution is a measure of the capability of a radar to display as separate targets the echoes received from two targets which are at the same range and are close together.

The principal factor which affects bearing resolution is horizontal beamwidth. Two targets at the same range must be separated by more than one beamwidth to appear as separate pips.

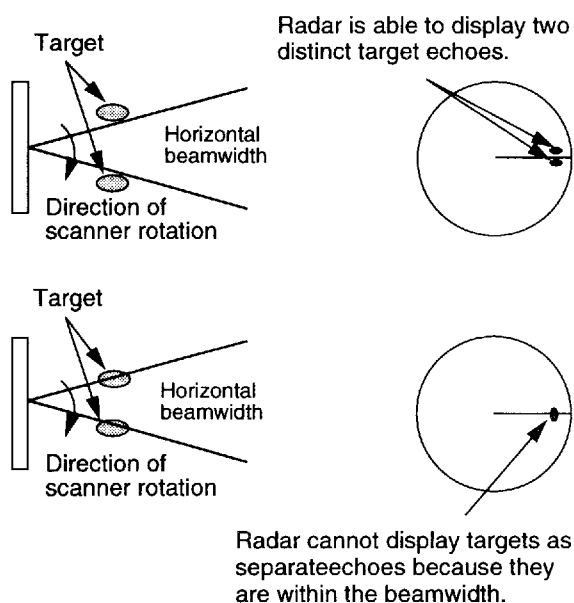

Figure 2-3 Bearing resolution

2.4 False Echoes

Indirect echoes

Indirect echoes may be returned from either a passing ship or returned from a reflecting surface on your own ship, for example, a stack. In both cases, the echo will return from a legitimate contact to the antenna by the same indirect path. The echo will appear on the same bearing of the reflected surface, but at the same range as the direct echo. Figure 2-4 illustrates the effect of an indirect echo. Indirect echoes may be recognized as follows: (1) they usually occur in a shadow sector; (2) they appear on the bearing of the obstruction but at the range of the legitimate contact; (3) when plotted, their movements are usually abnor-

mal, and (4) their shapes may indicate they are not direct echoes.

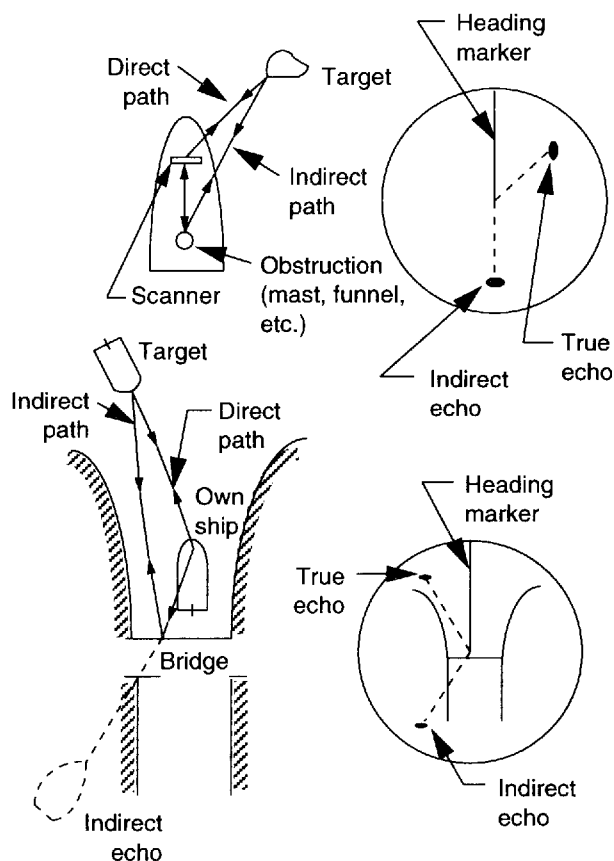

Figure 2-4 Indirect echoes

Multiple echoes

Multiple echoes occur when a short range, strong echo is received from a ship, bridge, or breakwater. A second, a third or more echoes may be observed on the display at double, triple or other multiples of the actual range of the target as shown in Figure 2-5. Multiple echoes can be reduced and often removed by decreasing the sensitivity or properly adjusting the STC.

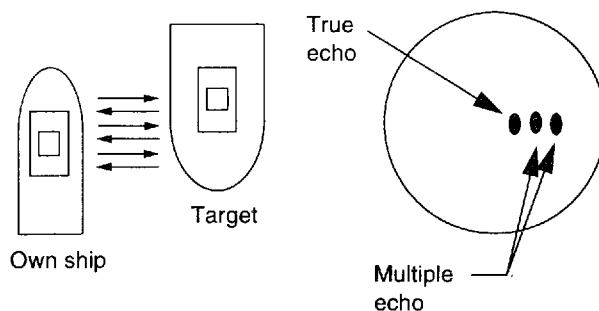

Figure 2-5 Multiple echoes

Side-lobe echoes

Small amounts of rf radiation on each side of the main beam are called "side-lobes." If a target exists where it can be detected by the side-lobes as well as the main-lobe, the side-lobe echoes may be represented on both sides of the true echo at the same range, as shown in Figure 2-6.

Side-lobes show usually only at short ranges and from strong targets. They can be reduced through careful reduction of the sensitivity or proper adjustment of the STC.

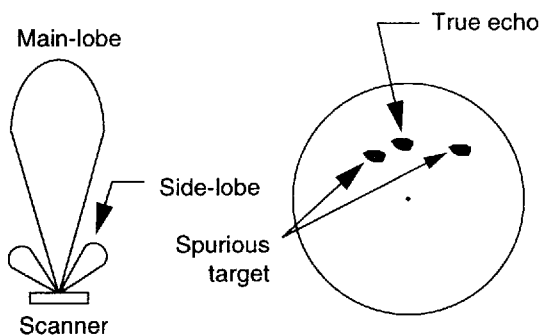

Figure 2-6 Side-lobe echoes

Blind and shadow sectors

Funnels, stacks, masts, or derricks in the path of antenna may reduce the intensity of the radar beam. Within the blind sector small targets at close range may not be detected while larger targets at much greater ranges may be detected. See Figure 2-7.

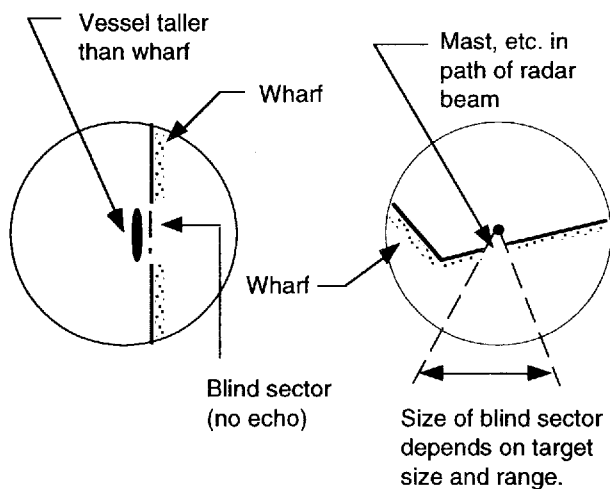

Figure 2-7 Blind and shadow sectors

2.5 Minimum and Maximum Ranges

Minimum range

The minimum range is defined by the shortest distance at which, using a scale of 1.5 or 0.75 nm, a target having an echoing area of 10 m² is still shown separate from the point representing the antenna position.

It is mainly dependent on the pulselength, antenna height, and signal processing such as main bang suppression and digital quantization. It is a good practice to use a shorter range scale as far as it gives favorable definition or clarity of picture. The IMO Resolution A. 477 (XII) and IEC 936 require the minimum range to be less than 50 m. All FURUNO radars satisfy this requirement.

Maximum range

The maximum detecting range of the radar, R_{max}, varies considerably depending on several factors such as the height of the antenna above the waterline, the height of the target above the sea, the size, shape and material of the target, and the atmospheric conditions.

Under normal atmospheric conditions, the maximum range is equal to the radar horizon or a little shorter. The radar horizon is longer than the optical one by about 6% because of the diffraction property of the radar signal. The R_{max} is given in the following equation.

$$R_{\max} = 2.2 \times (\sqrt{h_1} + \sqrt{h_2})$$

where R_{max}: radar horizon (nautical miles)
 h₁: antenna height (m)
 h₂: target height (m)

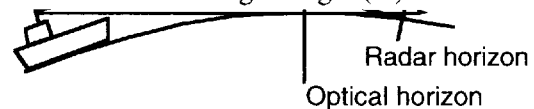

For example, if the height of the antenna above the waterline is 9 meters and the height of the target is 16 meters, the maximum radar range is;

$$R_{\max} = 2.2 \times (\sqrt{9} + \sqrt{16}) = 2.2 \times (3 + 4) = 15.4 \text{ nm}$$

2.6 Locating a Ship or Survival Craft in Distress by SART

SART background

The SART is required on vessels of 300 GT and above by the 1974 SOLAS Convention as amended in 1988 (GMDSS). Performance standard is specified in IMO Resolution A.697 (17).

SART activating conditions

The SART should operate correctly when interrogated at a distance of up to at least five miles by a navigational radar complying with resolutions A.477(XII) and A.422(VII) and IEC 936, with an antenna height of 15 meters. (It should also operate correctly when interrogated at a distance of up to 30 miles by an airborne radar with at least 10 kW peak output power at a height of 3,000 feet.)

How SART works

Upon receiving a radar signal from a rescue party, the SART automatically transmits a series of twelve frequency sweeps at a frequency between 9200 (+0/-60 MHz) and 9500 MHz (-0/+60 MHz). The radar will represent twelve SART marks during one sweep cycle on the screen. See the Figure 2-8.

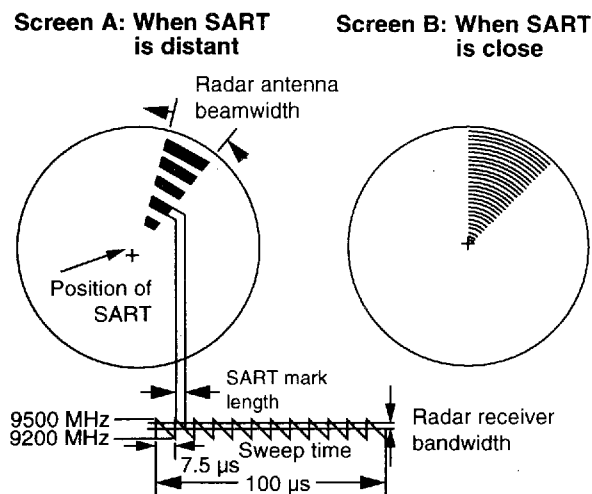

Figure 2-8 Appearance of SART marks on the radar display

The length of a SART mark depends on the radar's receiver bandwidth and sensitivity. For the bandwidth of 12 MHz, the length is 45 meters approximately and for the bandwidth of 3 MHz (usually on the 6 mile range or larger), 12 meters approximately.

How to show SART marks on the display

Detune the radar receiver manually by turning the TUNE control out of best tuning condition. This erases or weakens all normal radar echoes; but, the SART marks are not erased because the SART response signal scans over all frequencies in the 9 GHz band. When the radar approaches the SART in operation, the SART marks will enlarge to large arcs, blurring a large part of the screen. Reduce the sensitivity and adjust the sea clutter control of the radar.

Summary to detect SART responses

1. Use range scale of 6 or 12 nm as the spacing between the SART responses is about 0.6 nm (1125 m) to distinguish the SART
2. Turn off the automatic clutter suppression.
3. Turn off the Interference Rejector.

General remarks on receiving SART

Radar range scale

When looking for a SART, it is preferable to use a range scale between **6 and 12 nautical miles**. This is because the spacing between the SART responses is about 0.6 nautical miles (1125 m) and it is necessary to see a number of responses to distinguish the SART from other responses.

SART range errors

There are inherent delays in the SART responses as the SART has a trigger delay and may also have to sweep through the whole radar band before reaching the frequency of the search radar. At medium ranges of about 6 nautical miles the range delay may be between about 150 meters and 0.6 nautical mile beyond the SART position.

As the SART is approached the radar will normally detect the initial fast sweep of the SART so that the double dots will appear. The range delay of the first dot should be no more than 150 meters beyond the SART position.

Radar bandwidth

This is normally matched to the radar pulselength and is usually switched with the range scale and the associated pulselength. Narrow bandwidths of 3-5 MHz are used with long pulses on long range and wide bandwidths of 10-25 MHz with short pulses on short ranges.

Any radar bandwidth of less than 5 MHz will attenuate the SART signal slightly, so it is preferable to use a medium bandwidth to ensure optimum detection of the SART. The Radar Operating Manual should be consulted about the particular radar parameters and bandwidth selection.

Radar side lobes

As the SART is approached, side lobes from the radar antenna may show the SART responses as a series of arcs or concentric ring. These can be removed by the use of the anti-clutter sea control although it may be operationally useful to observe the side lobes as these will confirm that the SART is near to the ship.

Detuning the radar

To increase the visibility of the SART in clutter conditions, the radar may be detuned to reduce the clutter without reducing the SART response. Radar with automatic frequency control may not permit manual detune of the equipment. Care should be taken in operating the radar detuned as other wanted navigational and anti-collision information may be removed. The tuning should be returned to normal operation as soon as possible.

Gain

For maximum range SART detection the normal maximum gain should be used.

Anti-clutter sea control

For optimum range SART detection, this control should be set to the minimum. Care should be exercised as target in sea clutter may be obscured.

Some sets have automatic/manual anti-clutter sea control facilities in which cases the operator should switch to manual.

Anti-clutter rain control

This should not be used when trying to detect SARTs as the SART responses may be removed by this control.

Some sets have automatic/manual anti-clutter rain control facilities in which case the operator should switch to manual.

** This information was created by CIRM and reviewed at NAV 39 and circulated as ANNEX 8 NAV 39/WP.2/Add.1.*

Chapter 3 MAINTENANCE & TROUBLESHOOTING

3.1 Maintenance

Maintenance program

Regular maintenance is important for good performance. A maintenance program should be established and should at least include the items listed in Table 3-1.

WARNING

Do not open the equipment.

High voltage which can shock, burn or cause serious injury exists inside the equipment. Do not work inside the equipment unless familiar with electrical circuits.

Table 3-1 Maintenance program

Period	Item	Check point	Action
3 to 6 months	Fixing bolts for antenna unit	Check for corrosion and if tightly fastened.	Replace corroded bolts. Coat new bolts with anti-corrosive sealant.
	Antenna unit cleanliness	Check for foreign material. (Foreign material on the antenna unit will cause a considerable drop in sensitivity.)	Clean the antenna unit with a freshwater-moistened cloth. Alcohol may be used. Do not use chemical cleaners to clean the equipment; they can remove paint and markings.
	Antenna unit cover	Check for cracks. Permanent damage to the unit's circuitry will result if water leaks inside.	If a crack is found, it should be temporarily repaired by using a small amount of sealing compound or adhesive. The unit should then be brought to your local dealer for permanent repairs.
	LCD	The LCD will, in time, accumulate a coating of dust which tends to dim the picture.	Wipe the LCD lightly with a soft cloth. Do not use chemical cleaners to clean the equipment; they can remove paint and markings.
6 months to 1 year	Display unit connectors	Check for tight connection and corrosion.	If corroded, see your dealer about replacement.

Replacing the fuse

The fuse (5A) in the power cable protects the equipment against reverse polarity of ship's mains, overcurrent, and equipment fault. If the fuse blows, find the cause before replacing it. Never use a fuse rated for more than 5A, since overfusing can cause serious damage to the equipment and void the warranty.

 CAUTION
Use the proper fuse.
Use of a wrong fuse can cause fire or equipment damage.

3.2 Troubleshooting

Table 3-2 provides simple troubleshooting procedures which the user can follow to restore normal operation.

Table 3-2 Troubleshooting

If...	But...	Then...
you pressed the [POWER] key to turn on the radar	the control panel does not light	<ul style="list-style-type: none"> • adjust DIMMER on the menu. • battery may have discharged. • check if fuse has blown.
	nothing appears on the display (panel lights) or display contrast is poor	try adjusting LCD tone.
the radar has warmed up and you pressed the [TX] key to transmit	"HD-SIG-MISSING" or "BP-SIG-MISSING" appears (no heading or bearing pulse input from antenna unit)	check that signal cable is tightly fastened.
you adjusted sensitivity (with the FTC switched OFF)	neither noise or targets appear (indications and markers do)	check signal cable for damage.
	neither indications or markers do (noise and targets do)	check signal cable for damage.
a key is pressed	nothing happens	key may be faulty. Contact your dealer.

Chapter 4 INSTALLATION

NOTICE

The installation of this radar requires certain electrical and mechanical skills. If the user has doubts about his or her skills, we recommend that the unit be installed by a qualified technician.

4.1 Antenna Unit Installation

Mounting considerations

When selecting a mounting location for the antenna unit keep in mind the following points.

- Install the antenna unit on the hardtop, radar arch or on a mast on an appropriate platform. (For sailboats, a mounting bracket is optionally available.) It should be placed where there is a good all-round view with, as far as possible, no part of the ship's superstructure or rigging intercepting the scanning beam. Any obstruction will cause shadow and blind sectors. A mast, for instance, with a diameter considerably less than the width of the antenna unit, will cause only a small blind sector. However, a horizontal spreader or crosstrees in the same horizontal plane would be a much more serious obstruction; place the antenna unit well above or below it.

Antenna unit mounted on top of wheelhouse

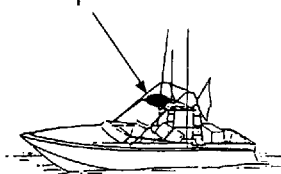

Antenna unit fixed to mast

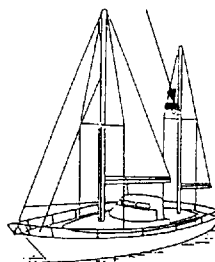

Figure 4-1 Typical antenna unit placement on powerboat and sailboat

- Locate the unit at least two meters away from a direction finder antenna to prevent interference to the direction finder.
- In order to minimize the chance of picking up electrical interference, avoid where possible routing the signal cable near other electrical equipment onboard. Also avoid running the cable in parallel with power cables.
- The compass safe distance of 2.0 meters (standard compass) and 1.5 meters (steering compass) should be observed to prevent deviation of the magnetic compass.

Mounting on a platform

1. Remove the antenna unit cover.
2. Remove mounting hardware at the bottom of the antenna unit; four each of hex bolts (M10 x 20), spring washers and flat washers. Save mounting hardware to use it to fix the antenna unit to the mounting platform later on.

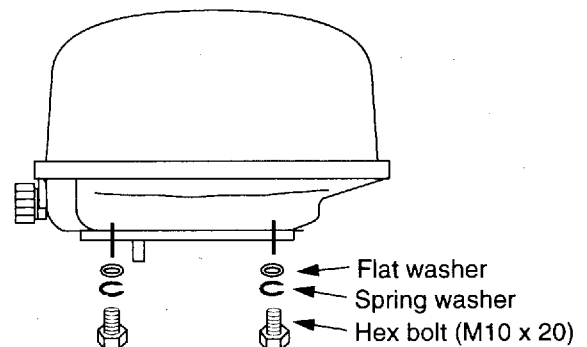

Figure 4-2 Antenna unit, showing location of mounting hardware

3. Construct a platform (wood, steel, or aluminum) of 5–10 mm in thickness whose dimensions are as shown in Figure 4-3. Fasten the platform to the mounting location.

Note: When drilling holes in the platform, be sure they are parallel with the fore and aft line.

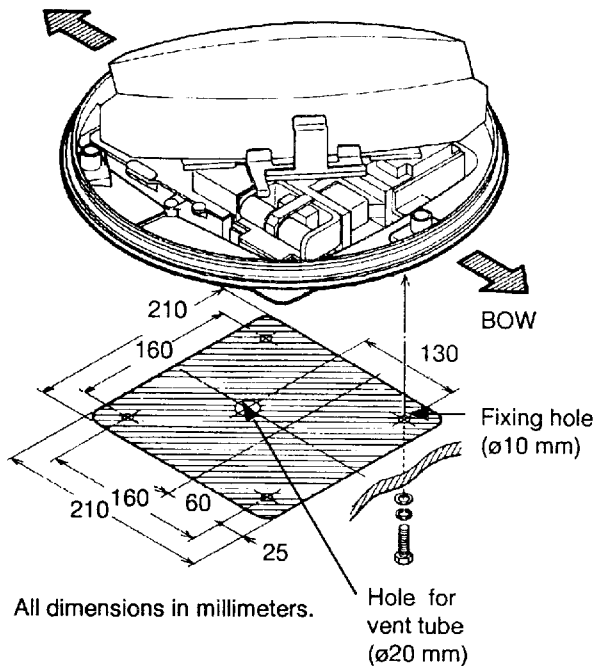

Figure 4-3 Dimensions of antenna platform

4. Drill a hole of 20 mm diameter through the platform for the vent tube.

ABOUT THE VENT TUBE

Moisture can condense inside the antenna unit, causing corrosion, if a means is not provided to keep moisture out of the unit. A vent tube fitted on the base of the unit allows the unit to "breathe" while not allowing entry of water from outside. Be sure the tube is kept free of foreign material and is not pinched or kinked. The vent tube extends downward by 27 mm from the base. Ensure the vent tube extends downward before mounting the base.

5. Find the cable entry on the antenna base. Next, position the base so the cable entrance faces the stern direction (this alignment must be as accurate as possible) and the vent tube is extending downward through the hole for the vent tube.
6. Using the hex bolts, flat washers and

spring washers removed at step 1, fasten the base to the platform. **DO NOT OVERTIGHTEN THE BOLTS—THE BASE MAY CRACK.**

Note: Longer hex bolts (M10 x 25) are supplied in the installation materials. Use them instead of the hex bolts removed earlier if the mounting platform is very thick.

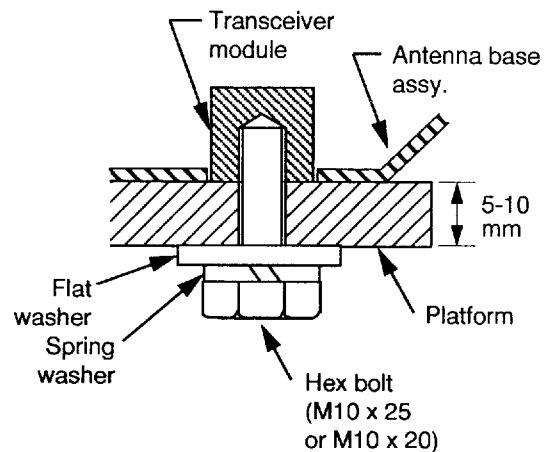

Figure 4-4 How to fasten the base to platform

7. Drill a hole of at least 20 mm diameter through the deck or bulkhead to run the signal cable between the antenna unit and the display unit.
8. Pass the signal cable through the hole. Seal the hole with sealing compound for waterproofing.
9. Referring to Figure 4-5, pass the signal cable through the hole at the rear of the antenna unit. Pass the cable through the gasket and cable gland, and then hand tighten the cable gland. Fasten the shield to a screw on the chassis to ground the unit.

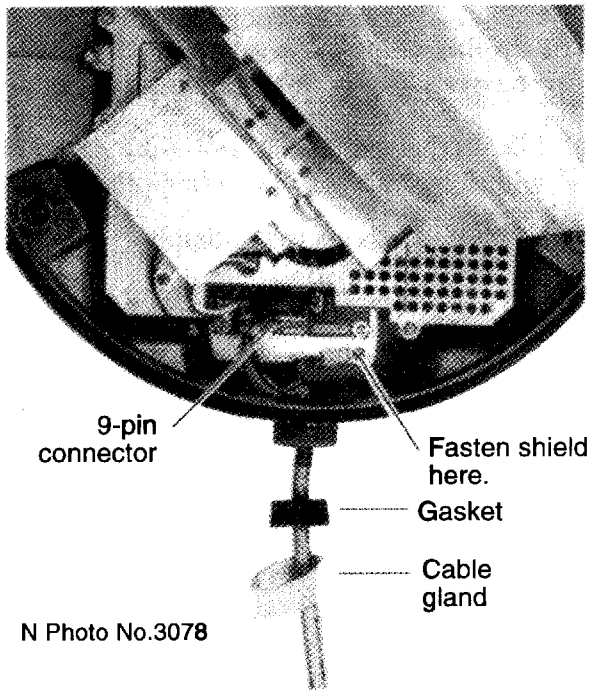

Figure 4-5 How to connect the signal cable to the antenna unit

10. Referring to Figure 4-5, connect the 9-pin connector.
11. Confirm that the gasket is positioned as shown in Figure 4-6. Place the cover on the base, facing the arrow on the antenna unit in the direction of the bow. Fasten the cover.

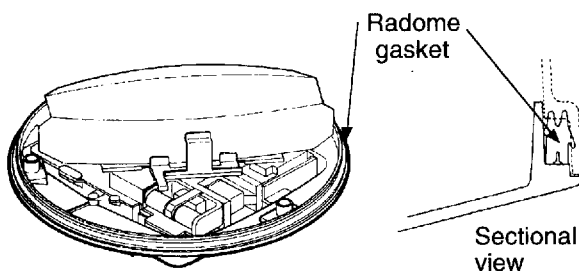

Figure 4-6 Proper position of gasket

12. Coat signal cable gland with sealing compound for waterproofing.

Mounting using the optional mounting bracket

A mounting bracket for fastening the antenna unit to a mast on a sailboat is optionally available. Mount it as follows:

1. Remove mounting hardware at the bottom of the antenna base. You may discard the hardware. Assemble the mounting bracket and fasten it to a mast. Fasten the antenna unit to the bracket.

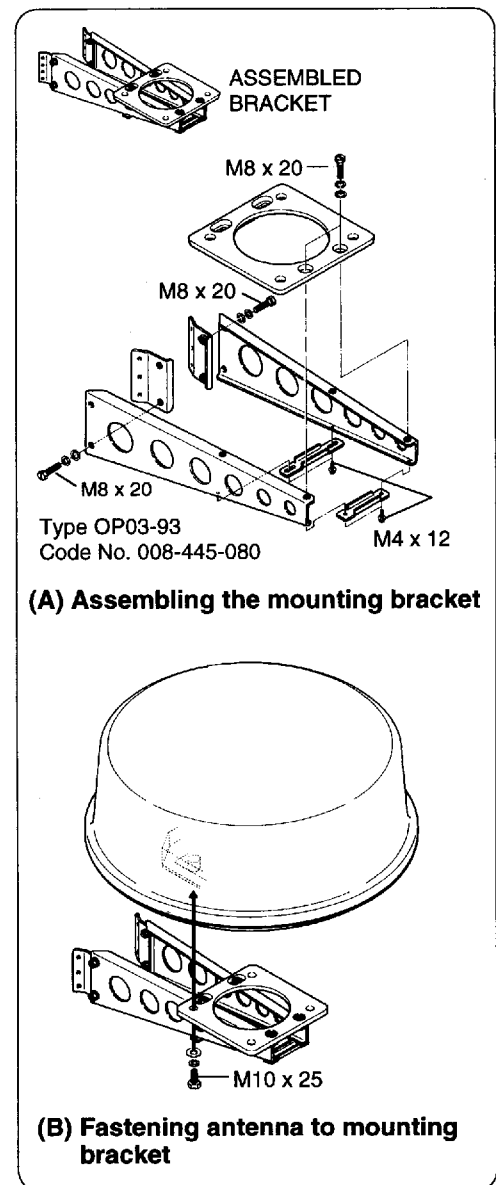

Figure 4-7 How to assemble and mount the optional mounting bracket

2. Follow steps 7-12 in "Mounting on a platform". (You will need to open the cover at step 9.)

4.2 Display Unit Installation

Mounting considerations

When selecting a mounting location for the display unit keep in mind the following points.

- Locate the display unit in a position where you can view and operate it conveniently.
- The orientation of the display unit should be so the radar screen is viewed while the operator is facing in the direction of the bow. This makes determination of your position much easier.
- The display unit is designed and constructed to be splashproof, thus it can be installed outdoors. You can even hose it down after a day's outing. If it is to be installed outdoors, we recommend installing it in an enclosed cabinet, for maximum protection against the marine environment.
- The display unit consumes only a moderate amount of power, so there is no need for forced air ventilation. However, you should provide adequate space behind and around the unit to permit circulation of air.
- Even though the picture is quite legible even in bright sunlight, keep the display unit out of direct sunlight or at least shaded because of heat that can build up inside the cabinet.
- The temperature and humidity of the mounting location should be stable and moderate. No LCD can provide adequate contrast if the ambient temperature is too low or too high.
- Make sure you allow enough clearance both to get to the connectors behind the unit and to allow you to get your hands in on both sides to loosen or tighten the mounting knobs. Make sure you leave at least a foot or so of "service loop" in cables behind the unit for servicing or easy removal of the connectors.
- The compass safe distance of 0.7 meters (standard compass) and 0.5 meters (steering compass) should be observed to prevent deviation of the magnetic compass.

Mounting

The display unit can be mounted on a table-top, the overhead, or flush mounted in a panel.

1. Fix the hanger to the mounting location with four tapping screws (supplied).
2. Fit the knob bolts to the display unit.
3. Cover the unused bolt holes with the blind films supplied.
4. Install the display unit in the hanger. Tighten the knob bolts securely.

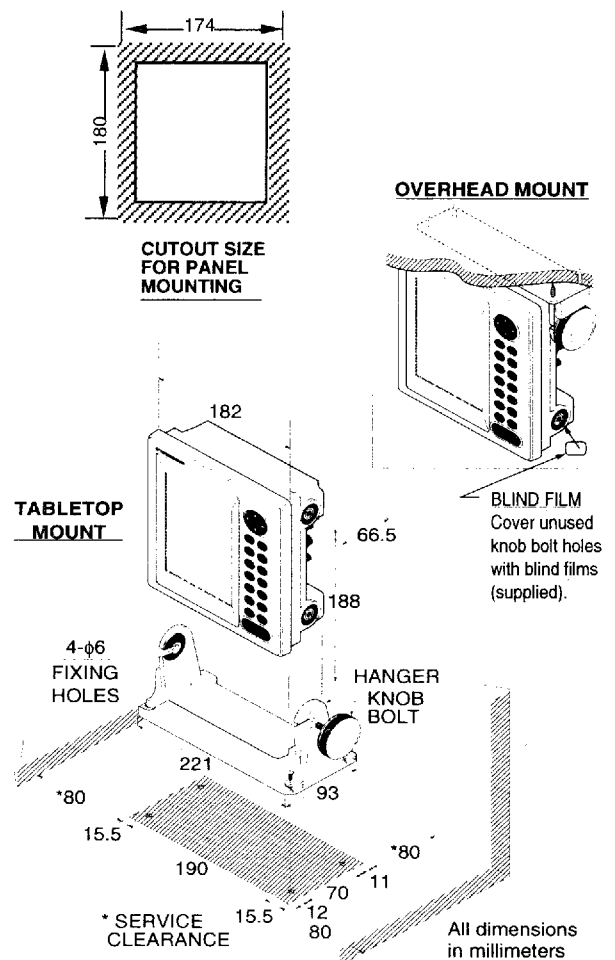

Figure 4-8 Mounting dimensions of display unit

4.3 Connections

Connect the signal cable, the power cable and the ground wire as shown in Figure 4-9.

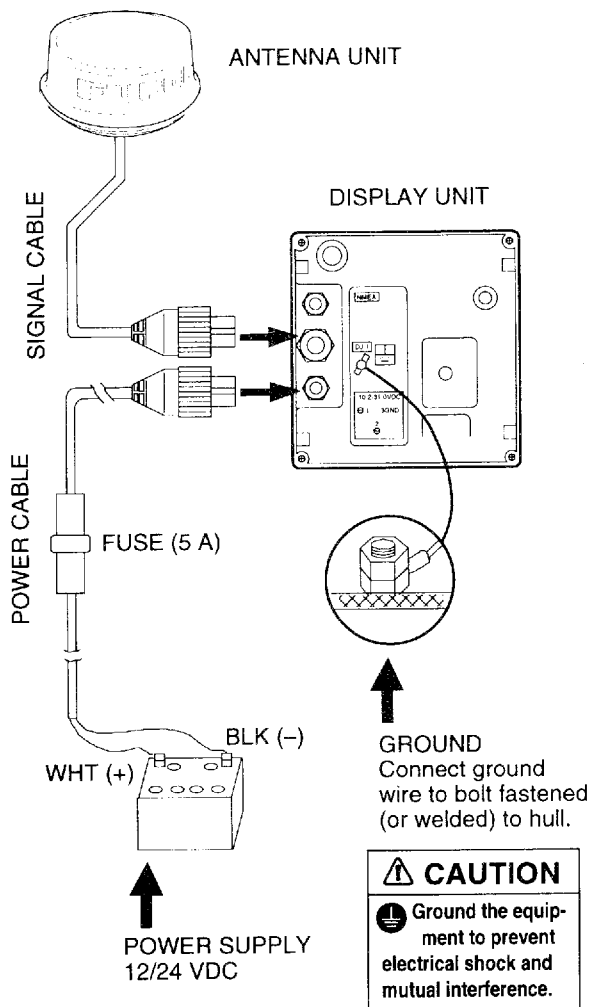

Figure 4-9 Connections

Connection of external equipment

Navigator/echosounder

This radar can receive the following data sentences in NMEA 0183 format:

- GLL: Geographic position - Lat/Long
- BWR: Bearing and Distance to Waypoint - Rhumb line
- BWC: Bearing and Distance to Waypoint
- GLC: Geographic Position - Loran-C
- GTD: Geographic Position - Time Difference
- RMA: Recommended Minimum Specific Loran-C Data

- RMB: Recommended Minimum Navigation Information
- RMC: Recommended Minimum Specific GPS/Transit Data
- VTG: Track Made Good and Ground Speed
- MTW: Water Temperature
- DBT: Depth Below Transducer
- DBS: Depth Below Surface
- DPT: Depth

Connection point on external equipment

The table on the next page shows where to connect the radar on various FURUNO equipment.

To receive data from multiple equipment (for example, GPS and echosounder), all data must be combined into one data line by using the NMEA Combiner Unit IF-2901.

Connection of IF-2901

NMEA Combiner Unit IF-2901 functions to connect multiple peripheral equipment to the radar.

When connecting it, solder jumper wires at both JP3-A and JP3-B on parts side of PCB DU-9193 in the radar display unit. They are located near J1352.

Cable to use

You will need an NMEA cable. (Several types are optionally available.) Connect it to the radar display unit as shown in Figure 4-10.

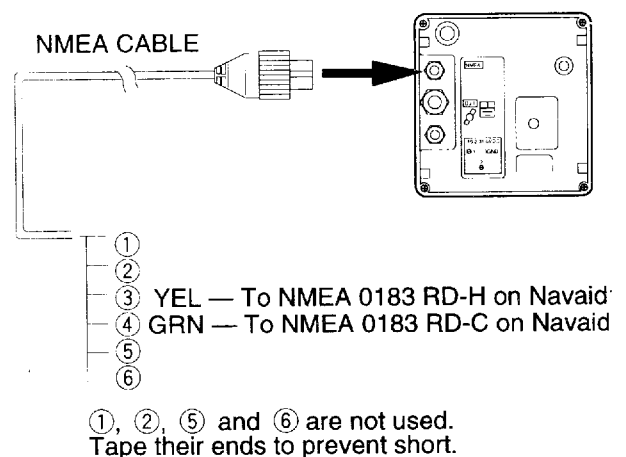

Figure 4-10 Navigator connection

Table 4-1 Connection of radar on external equipment

Model	FCV-665	FMV-605	FCV-581	T-2000	GP-50 M3	GP-50 M3	GP-70 MK2/ GP-80	GP-500 M2	GP-500 M2	LC-90 M2								
Output port	J12	J12	NMEA(J2)	V/F	OUTPUT	DATA OUT	DATA-1/ DATA-2/ †DATA-3	DATA OUT	DATA IN/ OUT	OUTPUT								
Connector type	MJ-A4SPF*	MJ-A4SPF*	MJ-A4SPF*	MJ-A4SPF*	XM2A0901X M290903	MJ-A6SPF*	MJ-A6SPF*	MJ-A6SPF*	XM2A-1501	SRCN6A16- 10P								
Signal name and pin no.	Pin no.	Signal name	Pin no.	Signal name	Pin no.	Signal name	Pin no.	Signal name	Pin no.	Signal name	Pin no.	Signal name	Pin no.	Signal name	Pin no.	Signal name	Pin no.	Signal name
	- 1 2	- TXD-H TXD-C	- 1 2	- TXD-H TXD-C	- 1 2	- TXD-H TXD-C	- 1 2 3 4 6 10 13 14	- TXD-H1 TXD-C1 TXD-H1 TXD-C1 GND GND	- 1 2 - 6	- TXD-H TXD-C - GND	- 10 11 9	- TXD-H TXD-C GND	- 5 6 - 10	- TXD-H TXD-C - GND				
Data format	NMEA 0183	NMEA 0183	NMEA 0183	NMEA 0183	NMEA 0183 NMEA 0180	NMEA 0183	NMEA 0183 NMEA 0180	NMEA 0183	NMEA 0183	NMEA 0183 NMEA 0180								
Selection of data format	-	-	Menu	DIP switch	Menu	Menu	Menu	Menu	Menu	-	Menu							
Remarks	* Cable assy. MJ-A6SPF011-x	* Cable assy. MJ-A6SPF011-x	* Cable assy. MJ-A6SPF011-x	* Cable assy. MJ-A6SPF011-x		* Cable assy. MJ-A6SPF012-x	* Cable assy. MJ-A6SPF012-x † GP-80 only	* Cable assy. MJ-A6SPF012-x										

Chart plotter RP-110L

Access J1 on the DU Board as shown in Figure 4-11. A connection cable is supplied with the RP-110L; connect it to J1. For connection at the RP-110L, see its installation manual.

External buzzer

Access J6 on the DU Board as shown in Figure 4-11. Plug in the connector of the external buzzer at J6. Seal the hole with sealing compound.

RP-110L
Make a hole of 20.4ø here.

External Buzzer
Make a hole of 16ø here. Seal hole with sealing compound after connecting cable.

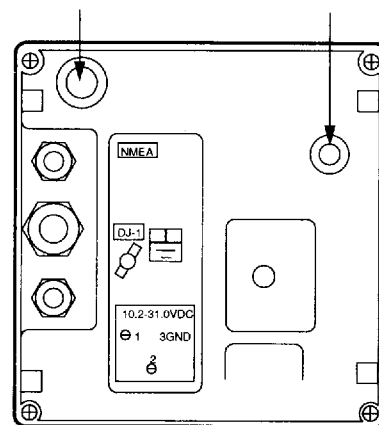

Note: Use hammer and appropriate metal rod to make hole(s).

Figure 4-11 Display unit, rear view

4.4 Installation Check

After installing the system it is a good idea to check it for proper installation, following the checklist provided below.

- The vent tube on the antenna unit is extending downward and is not kinked or pinched.
- Four fixing bolts securing the antenna unit are securely tightened.
- The signal cable is waterproofed at the base of the antenna unit.
- The signal cable is securely retained against the mast or mounting and is free of interference from running rigging.
- The cable gland on the deck or bulkhead is waterproofed, if provided.
- Connectors of external equipment are securely plugged into the radar display unit.
- The power connections to the battery are of correct polarity.

4.5 Adjustments

Do the following in order to adjust the radar.

⚠ WARNING

The radar antenna emits microwave radiation which can be harmful to the human body, particularly the eyes. Never look directly into the antenna radiator from a distance of less than 1 m when the radar is in operation.

1) Adjustment of picture

1. Press the [POWER] key on the display unit. The display should light. In approximately 1 minute and 30 seconds, ST-BY appears at the screen center.
2. When ST-BY appears press the [TX] key. The radar will start transmitting, and you

will probably see some targets, even though the radar is not yet properly adjusted.

3. Adjust the sensitivity to display a small amount of noise on the screen.
4. Press the [-] key several times to select the minimum range. Adjust the STC to display nearby radar targets clearly on the screen. Too much STC action will eliminate small targets, and too little STC action will cause the screen to be so full of targets and noise that it is hard to determine which target is which as compared to visual sightings.

2) Heading alignment

You have mounted the antenna unit facing straight ahead in the direction of the bow. Therefore, a small but conspicuous target dead ahead visually should appear on the heading mark (zero degrees).

In practice, you will probably observe some small error on the display because of the difficulty in achieving accurate initial positioning of the antenna unit. The following adjustment will compensate for this error, up to ± 30 degrees.

1. Identify a suitable target (for example, ship or buoy) at a range between 1/8 to 1/4 miles, preferably near the heading mark. To minimize error, keep echoes in the outer half of the picture by changing the range.
2. Press and hold down ◀ and ▶ together (about 10 seconds) to display the installation menu.

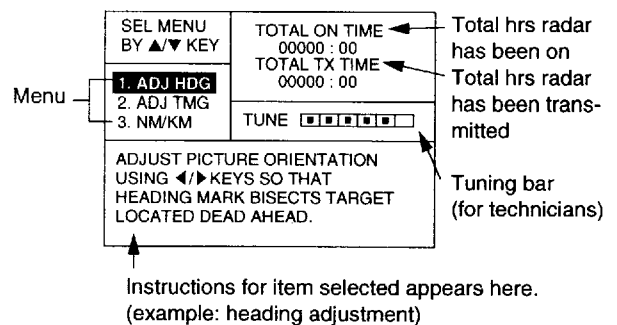

Figure 4-12 Installation menu

3. Select ADJ HDG. Your display should now look something like the one shown in Figure 4-13.

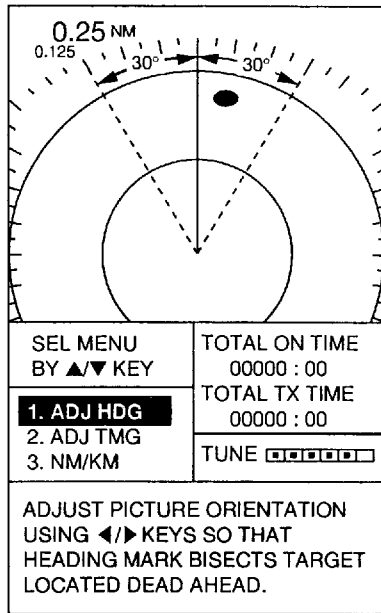

Figure 4-13 Display for adjustment of heading

4. Press ◀/▶ to bisect the target selected at step 1 with the heading marker.

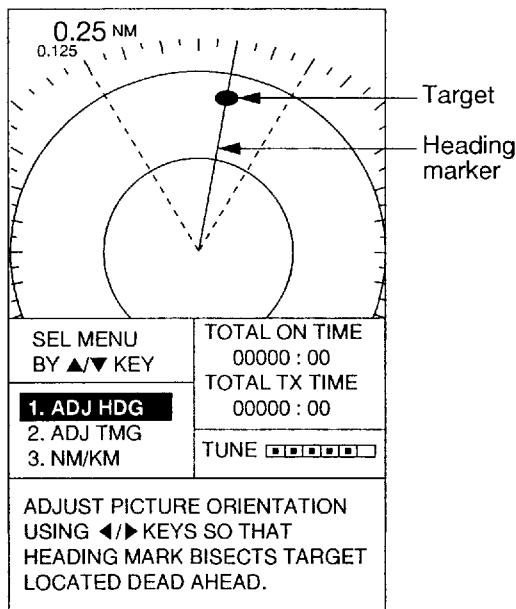

Figure 4-14 How to adjust heading

5. As a final test, move the boat towards a small buoy and confirm that the buoy shows up dead ahead on the radar when it is visually dead ahead.

3) Sweep timing

This adjustment ensures proper radar performance, especially on short ranges. The radar measures the time required for a transmitted echo to travel to the target and return to the source. The received echo appears on the display based on this time. Thus, at the instant the transmitter is fired, the sweep should start from the center of the display (sometimes called sweep origin.)

A trigger pulse generated in the display unit goes to the antenna unit through the signal cable to trigger the transmitter (magnetron). The time taken by the signal to travel up to the antenna unit varies, depending largely on the length of signal cable. During this period the display unit should wait before starting the sweep. When the display unit is not adjusted correctly, the echoes from a straight local object (for example, a harbor wall or straight pier) will not appear with straight edges – namely, they will be seen as pushed out or pulled in near the picture center. The range of objects will also be incorrectly shown.

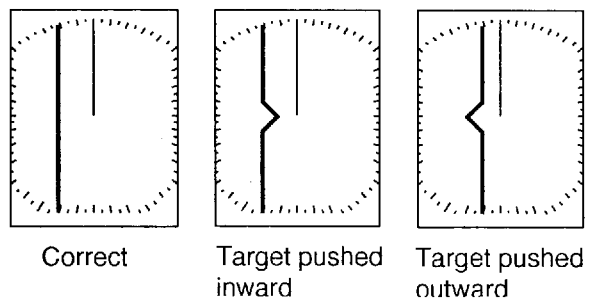

Figure 4-15 Examples of improper and correct sweep timings

1. Transmit the radar on the shortest range and adjust the sensitivity and STC.
2. Visually select a straight echo (harbor wall, straight pier).
3. Select ADJ TMG on the menu.

SEL MENU BY ▲/▼ KEY	TOTAL ON TIME 00000 : 00 TOTAL TX TIME 00000 : 00
1. ADJ HDG 2. ADJ TMG 3. NM/KM	TUNE <input type="text"/>
IDENTIFY STRAIGHT TARGET SUCH AS BREAKWATER. MAKE ITS ECHO STRAIGHT ON SCREEN USING ◀/▶ KEYS.	

Figure 4-16 Installation menu, ADJ TMG selected

4. While looking at the target selected at step 2, straighten it by pressing ◀ if it is pulled inward, or ▶ if it is pushed outward.

4) Unit of range measurement for VRM and cursor

The unit of range measurement for the VRM and the cursor may be selected to nautical mile or kilometers as follows:

1. Select NM/KM on the menu.

SEL MENU BY ▲/▼ KEY	TOTAL ON TIME 00000 : 00 TOTAL TX TIME 00000 : 00
1. ADJ HDG 2. ADJ TMG 3. NM/KM	TUNE <input type="text"/>
RANGE UNIT PRESS ◀/▶ KEYS TO SELECT NAUTICAL MILE OR KILOMETER AS THE UNIT OF RANGE.	

Figure 4-17 Installation menu, NM/KM selected

2. Select unit of range desired.
3. Press the [MENU] key to close the installation menu.

4.6 Adjustments for Technicians

1) Magnetron heater voltage

Magnetron heater voltage is formed at the SD Board of the antenna unit and preadjusted at the factory for use with any length of signal cable. Therefore no adjustment is required. However, verify heater voltage as follows:

1. Turn on the power. Do not transmit the radar.
2. Connect a multimeter, set to 10 V DC range, between #6(+) and #4(-) of test point TP804 on the SD Board in the antenna unit.
3. Confirm that the multimeter shows 8.0 V ± 0.1 V. If it does not, adjust potentiometer VR801 on the SD Board.

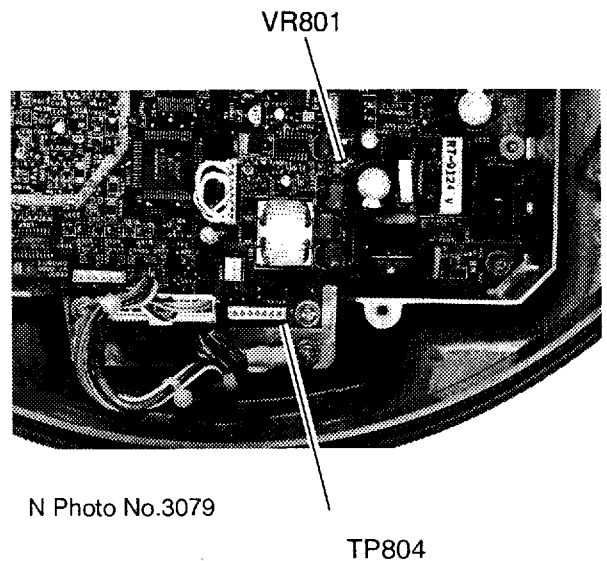

N Photo No.3079

Figure 4-18 Antenna unit, inside view

2) Radar function

This radar can function as the main radar or a demonstration model, displaying internally generated radar echoes. The demonstration function requires the EG Board (option).

1. Set the radar in stand-by.
2. Press and hold down ▲ and ▼ together (about 10 seconds) to display the maintenance menu.

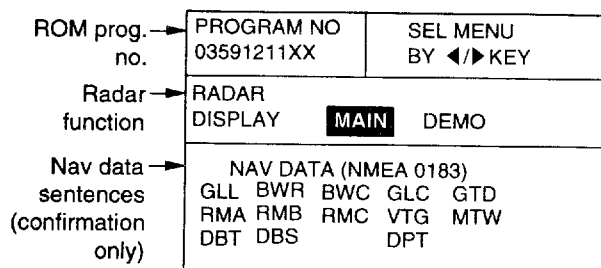

* Nav data sentences highlighted if corresponding data is input to the radar.

Figure 4-19 Maintenance menu

3. Select MAIN or DEMO.
4. Press the [MENU] to close the menu.

4.7 Restoring Default Settings

All default menu settings can be restored by turning on the power while pressing and holding down [MENU] and ▼.

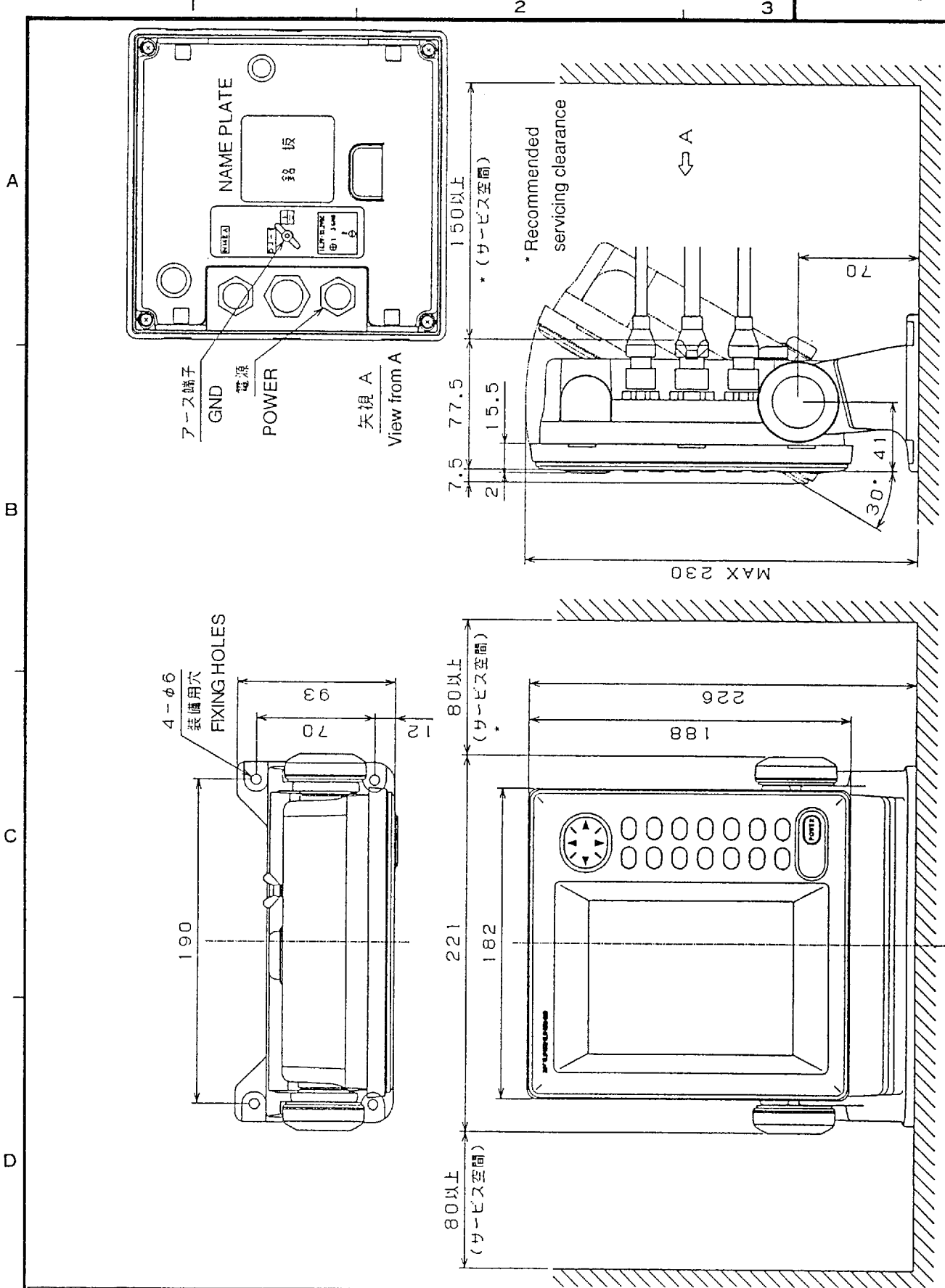

DRAWN MAR 25 '96 T. YAMASAKI				TYPE RDP-116	
CHECKED MAR 25 '96 K. OKAMOTO				名称 指示部	
APPROVED MAR 25 '96 K. OTA		M1621M2		外寸図	
SCALE X	MASS 2.0 kg	APPLICABLE TO: (MODEL)	BLOCK NO.	NAME DISPLAY UNIT	
DWG. NO. C3428-G01- A		03-135-1000- G0		OUTLINE DRAWING	

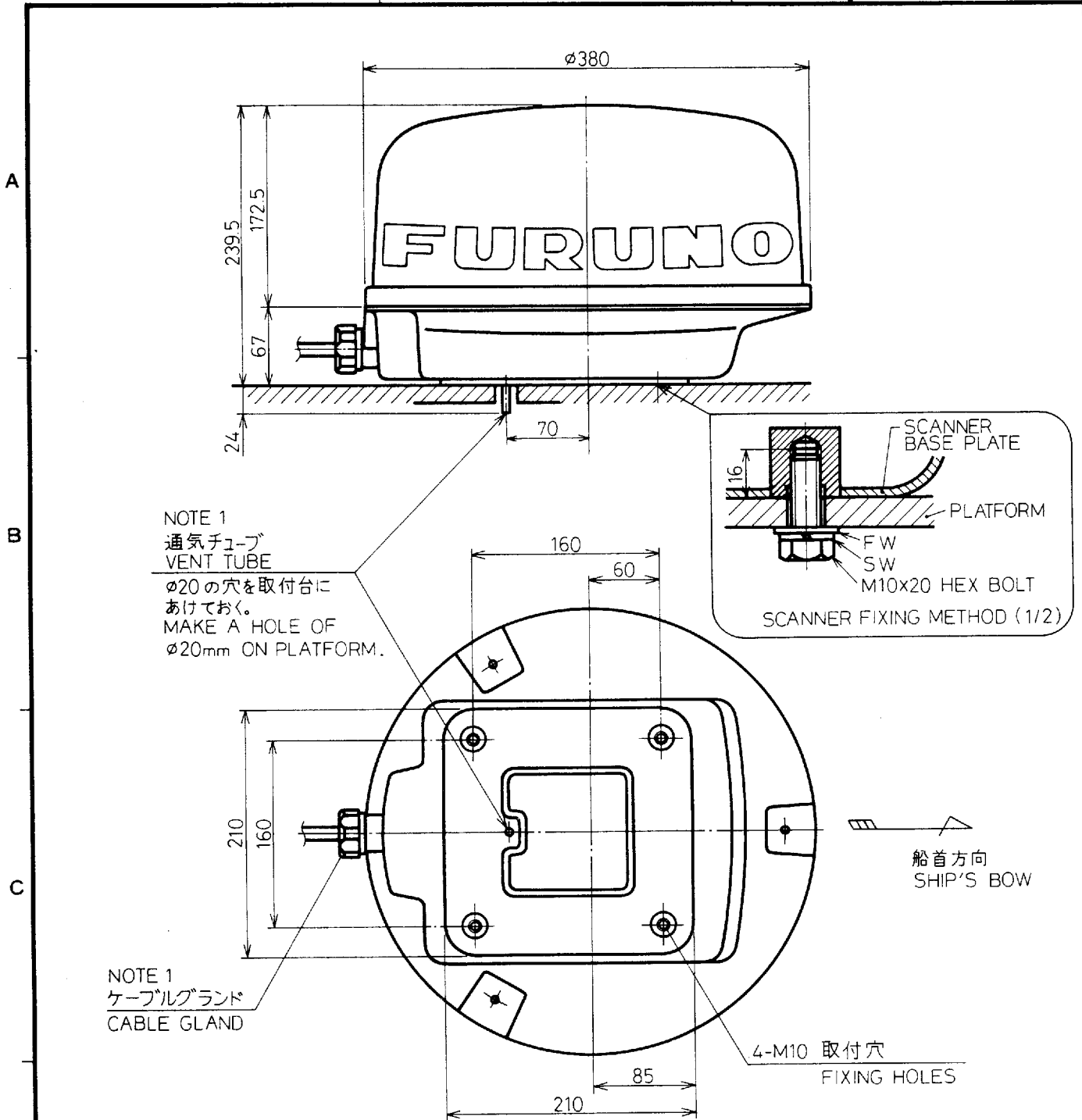

NOTE 1: 通気チューブ及びケーブルグランドは出荷時に取付済。
 VENT TUBE AND CABLE GLAND ARE FITTED AT FACTORY.
 NOTE 2: コンパス安全距離。
 COMPASS SAFE DISTANCE.

	M-1621	M-1621 M2
スタンダード STANDARD	1.7 m	2.0 m
ステアリング STEERING	1.3 m	1.5 m

MODEL 1621
 MODEL 1621 M2

承認 APPROVED	品番 ITEM	品名 NAME	材質 MATERIAL	数量 Q'TY	図番 DWG. NO.	摘要 REMARKS
DEC. 1 '92 M. IKEDA		三角法 THIRD ANGLE PROJECTION				名称 TITLE レーダー空中線部外寸図
検図 CHECKED	DEC. 1 '92 TAKAHASHI	尺度 SCALE		1 / 5	RSB-0060	RADAR SCANNER UNIT
製図 DRAWN	DEC. 1 '92 N. SAITO	重量 WEIGHT		5 kg	図番 DWG. NO.	C3378 - G02 - D

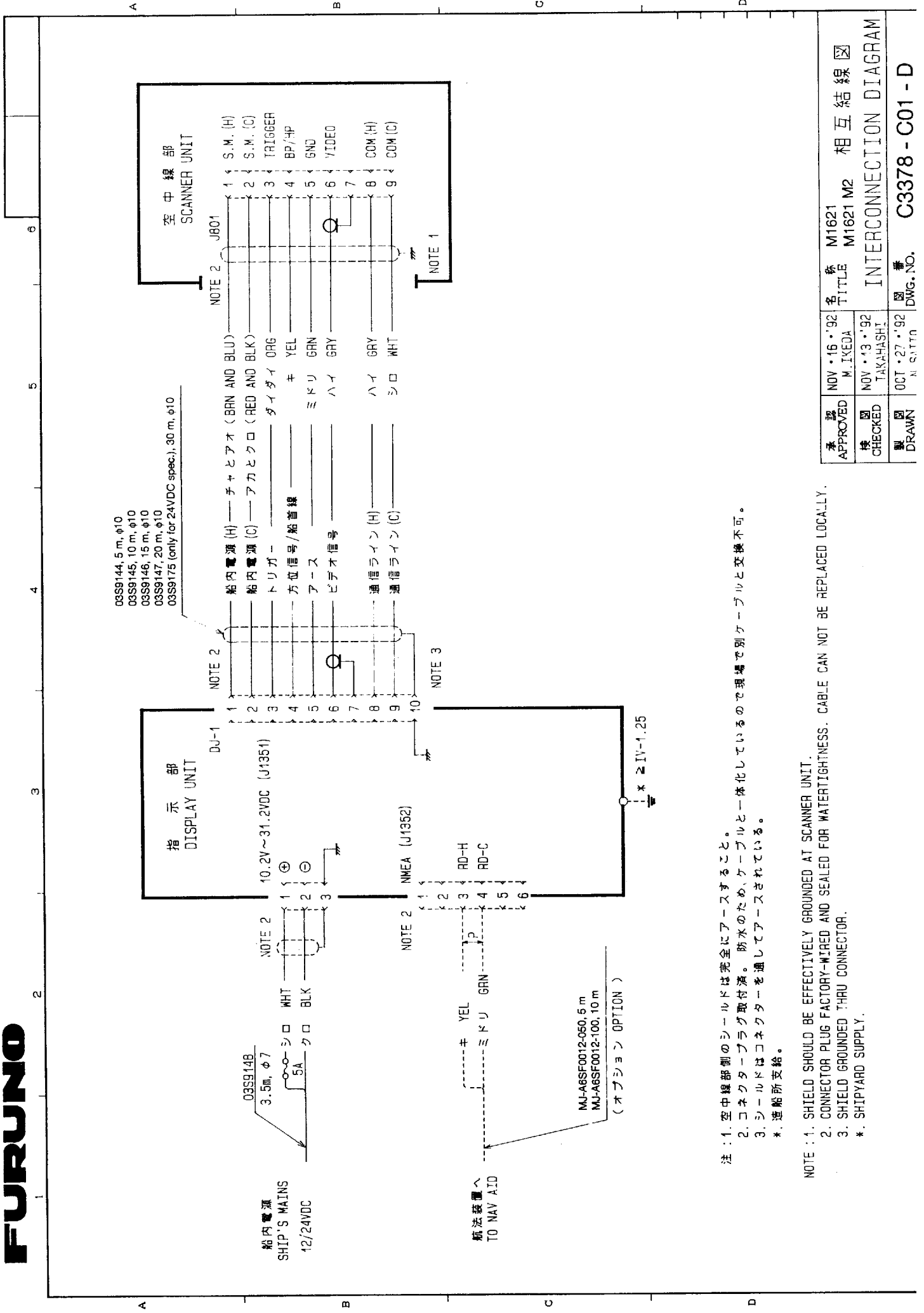

承認 APPROVED	NOV・16・92 M. IKEDA	名称 TITLE	M1621 M1621 M2	相互結線図 INTERCONNECTION DIAGRAM
検図 CHECKED	NOV・13・92 TAKAHASHI	製図 DRAWN	OCT・27・92 N. SATTO	図番 DWG. NO.
				C3378 - C01 - D

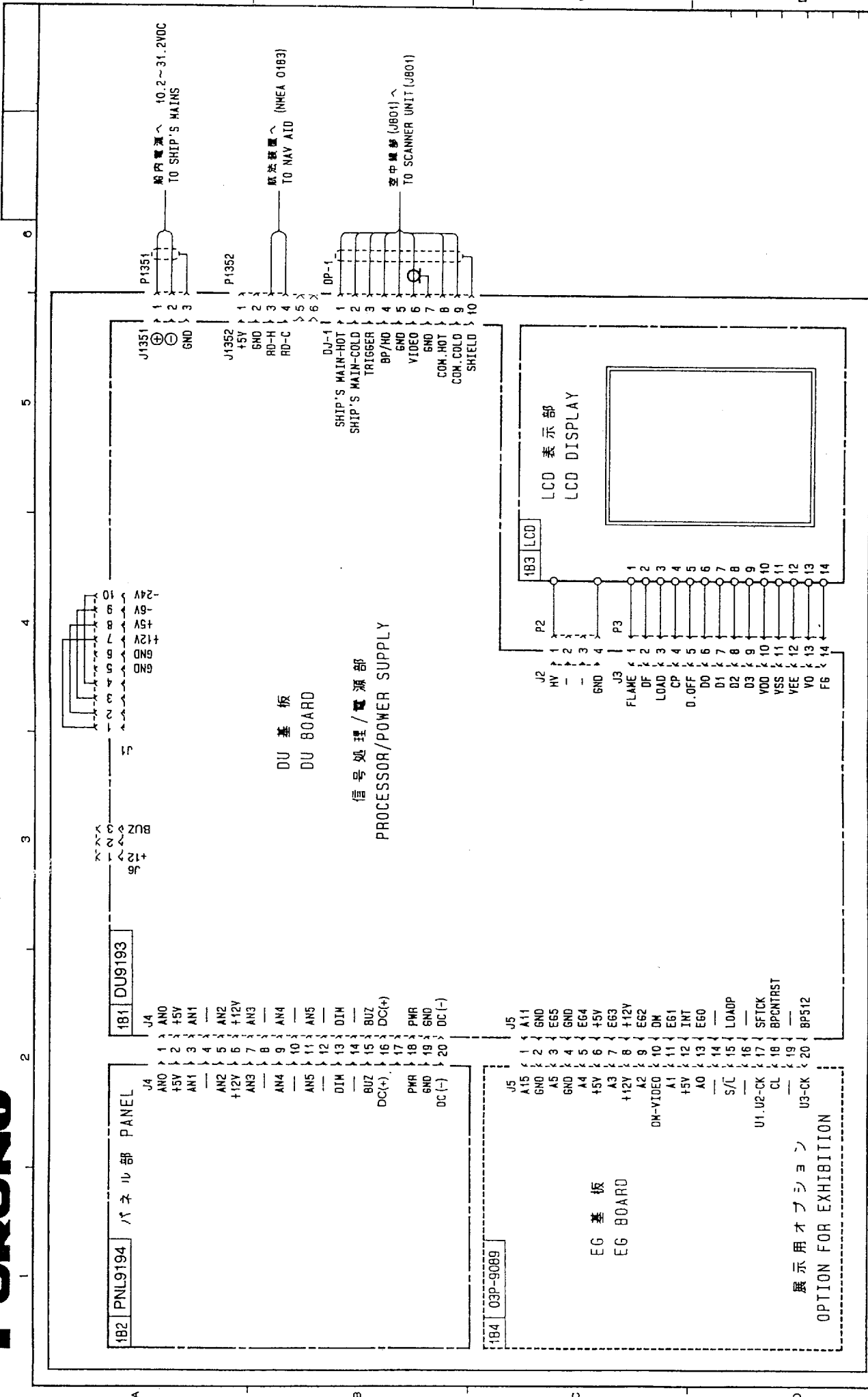

DRAWN MAR 24 '96 T. TAKASAKI	TYPE RDP-116
CHECKED MAY 25 '96 K. KAWAMOTO	名称 指示部
APPROVED MAY 25 '96 K. UTAH	回路図
SCALE 1/8	BLOCK NO.
NAME DU BASE BOARD	APPLICABLE TO: (MODEL) M1621M2
DATE MAR 24 '96	DISPLAY UNIT

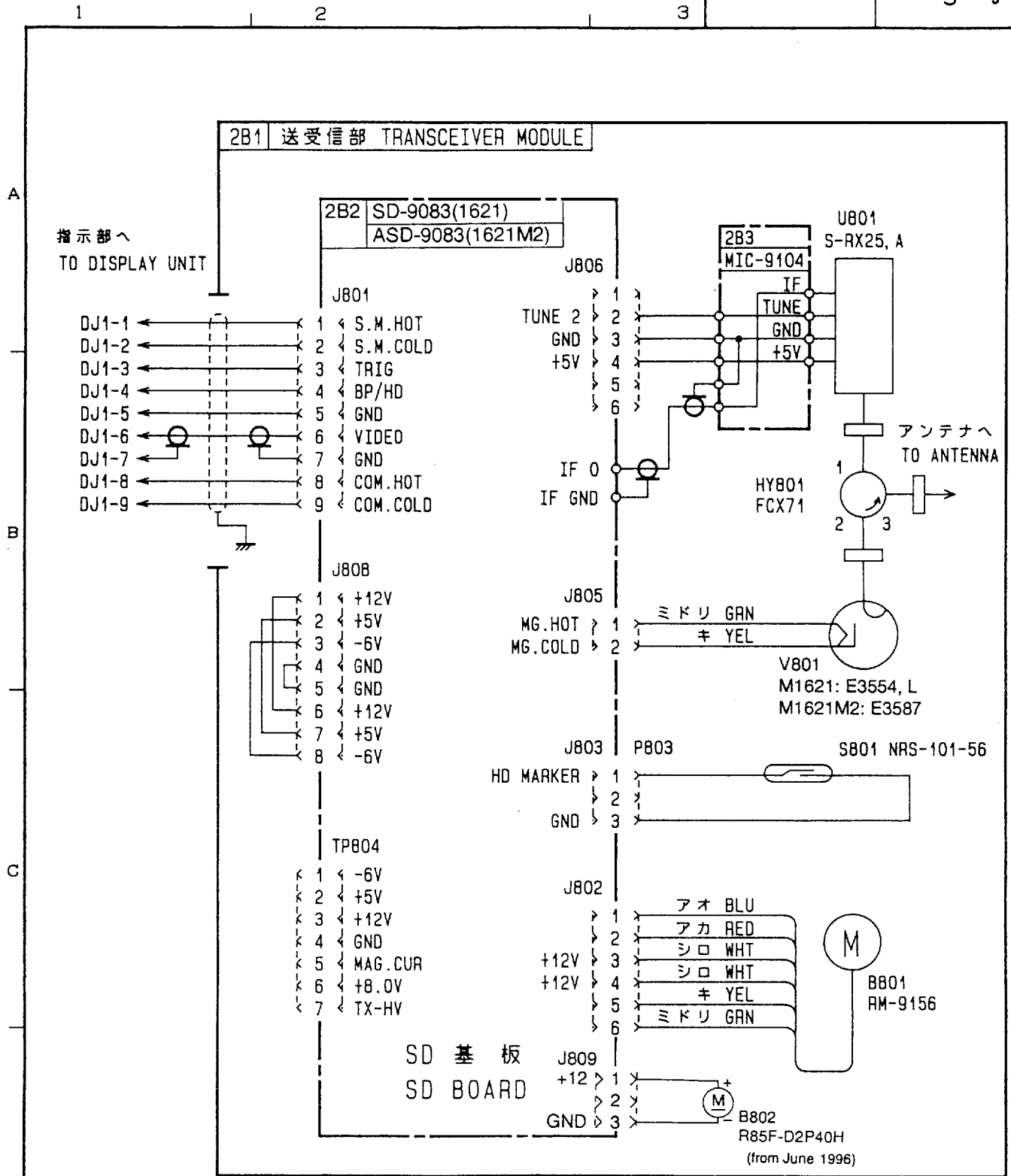

MODEL 1621
MODEL 1621 MARK2

承認 APPROVED	NOV・16・'92 M. IKEDA	名称 TITLE	空中線部 SCANNER UNIT
検 CHECKED	NOV・13・'92 TAKAHASHI	RSB-0060	
製 DRAWN	OCT・27・'92 N. SAITO	番 DWG. NO.	C3378 - K01 - D

Free Manuals Download Website

<http://myh66.com>

<http://usermanuals.us>

<http://www.somanuals.com>

<http://www.4manuals.cc>

<http://www.manual-lib.com>

<http://www.404manual.com>

<http://www.luxmanual.com>

<http://aubethermostatmanual.com>

Golf course search by state

<http://golfingnear.com>

Email search by domain

<http://emailbydomain.com>

Auto manuals search

<http://auto.somanuals.com>

TV manuals search

<http://tv.somanuals.com>