

# MARINE RADAR

## FCR-2827W/2837SW/2827W-D/2837SW-D

### *Installation manual*

Comply with MSC.192(79)

<b>SAFETY INSTRUCTIONS.....</b>	<b>i</b>	<b>3. SETTING AND ADJUSTMENT .....</b>	<b>3-1</b>
<b>EQUIPMENT LISTS .....</b>	<b>iii</b>	3.1 Radar Processor Unit.....	3-1
<b>SYSTEM CONFIGURATION .....</b>	<b>vi</b>	3.2 Setting IP Address.....	3-2
<b>1. MOUNTING .....</b>	<b>1-1</b>	3.3 Setting Radar Number .....	3-6
1.1 Antenna Unit .....	1-1	3.4 Initializing Tuning.....	3-8
1.2 Monitor Unit .....	1-12	3.5 Heading Alignment .....	3-9
1.3 Control Unit.....	1-15	3.6 Sweep Timing.....	3-11
1.4 Radar Processor Unit .....	1-19	3.7 Suppressing Main Bang .....	3-12
1.5 Transceiver Unit.....	1-20	3.8 Other Settings .....	3-12
1.6 Chart Processor Unit .....	1-21	3.9 Saving and Restoring Radar Initialize Parameters.....	3-19
1.7 LAN Adapter/B Adapter.....	1-22	3.10 Parameters.....	3-22
<b>2. WIRING .....</b>	<b>2-1</b>	3.11 Adjustments for LAN Adapter EC-1010 .....	3-42
2.1 Interconnection .....	2-1	3.12 DIP Switches and Jumper Wires.....	3-48
2.2 Antenna Unit .....	2-3	<b>4. INSTALLING OPTIONAL EQUIPMENT .....</b>	<b>4-1</b>
2.3 Transceiver Unit.....	2-12	4.1 Gyro Converter GC-10 .....	4-1
2.4 Monitor Unit .....	2-17	4.2 Junction Box.....	4-9
2.5 Radar Processor Unit .....	2-18	4.3 B Adapter.....	4-13
2.6 Changing AC Power Specification of Radar Processor Unit .....	2-23	<b>5. INPUT/OUTPUT DATA .....</b>	<b>5-1</b>
2.7 Chart Processor Unit .....	2-25	5.1 Radar Processor Unit.....	5-1
2.8 LAN Adapter .....	2-25	5.2 Chart Processor Unit.....	5-2
2.9 VDR .....	2-28	<b>OTLINE DRAWINGS .....</b>	<b>D-1</b>
2.10 EMI Core for chart Processor Unit...	2-28	<b>INTERCONNECTION DIAGRAM .....</b>	<b>S-1</b>

**ECF**

(Elemental Chlorine Free)

The paper used in this manual  
is elemental chlorine free.

**FURUNO ELECTRIC CO., LTD.**

9-52 Ashihara-cho,  
Nishinomiya, 662-8580, JAPAN

Telephone : +81-(0) 798-65-2111

Fax : +81-(0) 798-65-4200

• FURUNO Authorized Distributor/Dealer

All rights reserved. Printed in Japan

Pub. No. IME-35640-E

(HIMA ) FCR-2827W/2837SW

A : SEP. 2007

E : MAR. 16, 2011



\* 0 0 0 1 5 8 0 5 9 1 4 \*



# SAFETY INSTRUCTIONS

The operator and installer must read the applicable safety instructions before attempting to install or operate the equipment.



## WARNING

Indicates a potentially hazardous situation which, if not avoided, could result in death or serious injury.



## CAUTION

Indicates a potentially hazardous situation which, if not avoided, can result in minor or moderate injury.



Warning, Caution



Prohibitive Action



Mandatory Action



## DANGER



**Wear a safety belt and hard hat when working on the antenna unit.**

Serious injury or death can result if someone falls from the radar antenna mast.



## WARNING



### Radio Frequency Radiation Hazard

The radar antenna emits electromagnetic radio frequency (RF) energy which can be harmful, particularly to your eyes. Never look directly into the antenna aperture from a close distance while the radar is in operation or expose yourself to the transmitting antenna at a close distance.

Distances at which RF radiation levels of 100, 50 and 10 W/m<sup>2</sup> are given in the table below.

**Note:** If the antenna unit is installed at a close distance in front of the wheel house, your administration may require halt of transmission within a certain sector of antenna revolution. This is possible. Ask your FURUNO representative or dealer to provide this feature.

Model	Transceiver	Magnetron	Antenna *	100W/m <sup>2</sup>	50W/m <sup>2</sup>	10W/m <sup>2</sup>
FCR-2827W FCR-2827W-D	RTR-081 (X-25 kw)	MG5436	XN-20AF XN-24AF	0.4 m 0.2 m	1.0 m 0.5 m	5.6 m 3.4 m
FCR-2837SW FCR-2837SW-D	RTR-082 (S-30 kw)	MG5223F	SN-36AF	--	0.2 m	1.9 m

\*XN20AF: 6.5 ft

XN24AF: 8 ft

SN36AF: 12 ft



## WARNING



Do not open the equipment unless totally familiar with electrical circuits and service manual.

**ELECTRICAL  
SHOCK  
HAZARD**

Only qualified personnel should work inside the equipment.

**Construct a suitable service platform from which to install the antenna unit.**

Serious injury or death can result if someone falls from the radar antenna mast.

**Turn off the power at the mains switchboard before beginning the installation.**

Fire, electrical shock or serious injury can result if the power is left on or is applied while the equipment is being installed.

**Be sure that the power supply is compatible with the voltage rating of the equipment.**

Connection of an incorrect power supply can cause fire or damage the equipment .

**Use only the specified power cable.**

Fire or damage to the equipment can result if a different cable is used.

**Do not install the monitor unit, processor unit or control unit where they may get wet from rain or water splash.**

Water in the units can result in fire, electrical shock, or damage the equipment.



**Attach securely protective earth to the ship's body.**

The protective earth (grounding) is required to the AC power supply to prevent electrical shock.



## CAUTION

**Observe the following compass safe distances to prevent deviation of a magnetic compass:**

	Standard compass	Steering compass
Antenna Unit (FCR-2827W/-D)	1.15 m	0.70 m
Antenna Unit (FCR-2837SW/-D)	1.35 m	0.85 m
Transceiver Unit (FCR-2827W-D)	2.00 m	1.30 m
Transceiver Unit (FCR-2837SW-D)	4.25 m	2.75 m
Chart Processor unit(EC-1000C)	0.85 m	0.50 m
Monitor Unit (MU-201CE)	2.25 m	1.40 m
Monitor Unit (MU-231CE)	2.55 m	1.55 m
Radar Processor Unit (RPU-016)	1.35 m	0.85 m
Control Unit (RCU-020)	0.30 m	0.30 m
Control Unit (RCU-015FEA)	0.95 m	0.60 m
Control Unit (RCU-016)	0.65 m	0.45 m
LAN Adapter (EC-1010)	1.05 m	0.70 m
B Adapter (EC-1020)	0.80 m	0.50 m
Junction Box (RJB-001)	1.10 m	0.70 m
Switching Hub (HUB-100)	1.00 m	0.60 m
Monitor Unit (MU-231)	0.85 m	0.55 m

# EQUIPMENT LISTS

## Standard Supply (FCR-2827W/2827W-D)

Name	Type	Code No.	Qty	Remarks
Antenna Unit	XN20AF-RSB103	-	1	24 rpm, 2000 mm w/CP03-19101*
	XN24AF-RSB103			24 rpm, 2400 mm w/CP03-19101*
Transceiver Unit	RTR-081			25 kW, X-band
Monitor Unit	MU-231CE		1	w/ power cable, for FAR-2827W
	MU-231			For FCR-2827W-D
Processor Unit#	RPU-016	-	1	For radar functions
Processor Unit#	EC-1000-C		1	For chart functions
Control Unit	RCU-020	-	1	Standard type
	RCU-015FEA			Trackball type
LAN Adapter	EC-1010	-	1	
Switching Hub	HUB-100	-	1	For IMO type only
Installation Materials	CP03-27502	008-540-140	1	For antenna unit
	CP03-31100	000-090-515	1	RW-9600 15 m, CP03-31101
	CP03-31110	000-090-516		RW-9600 30 m, CP03-31101
	CP03-31120	000-090-517		RW-9600 50 m, CP03-31101
	CP03-31130	000-090-518		RW-9600 40 m, CP03-31101
	CP03-31140	000-090-519		RW-9600 15 m, CP03-31102
	CP03-31150	000-090-520		RW-9600 30 m, CP03-31102
	CP03-31160	000-090-521		RW-9600 50 m, CP03-31102
	CP03-31170	000-090-522		RW-9600 40 m, CP03-31102
	CP03-25800	000-080-434	1	Cable assy. for monitor unit
	CP03-25602	008-535-940	1	For RPU-016
	CP03-29100	000-087-219	1	For EC-1000C
	CP03-25604	008-539-850	1	For control unit
	CP03-27501	008-540-200	1	For transceiver unit
	Rectangular waveguide installation materials	CP03-16400*	000-086-743	1
Rectangular guide installation materials	CP03-16410	000-086-744	1	20 m rectguide, w/CP03-16411*
	CP03-16420	000-086-745		30 m rectguide, w/CP03-16411*
	CP03-16430	000-086-746		50 m rectguide, w/CP03-16411*
Accessories	FP03-09810	008-536-010	1	For monitor unit
	FP03-09850	008-535-610	1	For RCU-020
	FP03-09860	008-535-690		For RCU-015FEA
	FP03-10700	000-087-221	1	For EC-1000C
Spare Parts	SP03-12501	008-485-360	1	For antenna unit
	SP03-14404	008-535-910	1	For RPU-016 100 VAC set
	SP03-14405	008-535-920		For RPU-016 220 VAC set
	SP03-14700	008-549-730	1	For monitor unit
	SP03-14800	000-083-570	1	For EC-1000C

#: This radar has two processor units: RPU-016 and EC-1000-C. In this book, RPU-016 is called "radar processor unit" and EC-1000-C is called "chart processor unit".

## Standard Supply (FCR-2837SW/2837SW-D)

Name	Type	Code No.	Qty	Remarks
Antenna Unit	SN30AF-RSB104	-	1	21 rpm, 3000 mm
	SN30AF-RSB105	-		26 rpm, 3000 mm
	SN36AF-RSB104	-		21 rpm, 3600 mm
	SN36AF-RSB105	-		26 rpm, 3600 mm
Transceiver Unit	RTR-082	-	1	30 kW, S-band
Monitor Unit	MU-231CE		1	w/ power cable, for FAR-2837SW
	MU-231			For FCR-2837SW
Processor Unit#	RPU-016	-	1	For radar functions
Processor Unit#	EC-1000-C		1	For chart functions
Control Unit	RCU-020	-	1	Standard type
	RCU-015FEA			Trackball type
LAN Adapter	EC-1010	-	1	
Switching Hub	HUB-100	-	1	For IMO type only
Installation Materials	CP03-27602	008-540-520	1	For antenna unit
	CP03-31100	000-090-515	1	RW-9600 15 m, CP03-31101
	CP03-31110	000-090-516		RW-9600 30 m, CP03-31101
	CP03-31120	000-090-517		RW-9600 50 m, CP03-31101
	CP03-31130	000-090-518		RW-9600 40 m, CP03-31101
	CP03-31140	000-090-519		RW-9600 15 m, CP03-31102
	CP03-31150	000-090-520		RW-9600 30 m, CP03-31102
	CP03-31160	000-090-521		RW-9600 50 m, CP03-31102
	CP03-31170	000-090-522		RW-9600 40 m, CP03-31102
	CP03-25800	000-080-434		1
	CP03-25602	008-535-940	1	For RPU-016
	CP03-29100	000-087-219	1	For EC-1000C
	CP03-25604	008-539-850	1	For control unit
	CP03-27601	008-540-570	1	For transceiver unit
	Coaxial Cable Installation materials	CP03-14900	000-086-325	1
CP03-14910		000-086-326	Coax. Cable LHPX-20DASSY* (L=30) (30 m), Converter PA-5600, CP03-13948*	
Accessories	FP03-09810	008-536-010	1	For monitor unit
	FP03-09850	008-535-610	1	For RCU-020
	FP03-09860	008-535-690		For RCU-015FEA
	FP03-10700	000-087-221	1	For EC-1000C
	FP03-10101	008-538-730		For antenna unit
Spare Parts	SP03-14404	008-535-910	1	For RPU-016 100 VAC set
	SP03-14405	008-535-920	1	For RPU-016 220 VAC set
	SP03-14700	008-549-730		For monitor unit
	SP03-14800	000-083-570	1	For EC-1000C

#: This radar has two processor units: RPU-016 and EC-1000-C. In this book, RPU-016 is called "radar processor unit" and EC-1000-C is called "chart processor unit".

## Optional Equipment

Name	Type	Code No.	Remarks
Gyro Converter	GC-10-2	000-080-440	See chapter 4.
Performance Monitor	PM-31	000-080-438	Mandatory for IMO radar (2827W)
	PM-51	-	Mandatory for IMO radar (2837SW)
Transformer Unit	RU-1803	-	Converts 440 VAC to 100 VAC, for processor unit
	RU-3305	-	Converts 110/115/220/230 VAC to 100 VAC, for de-icer
	RU-5693	000-030-456	Converts 110 VAC to 220 VAC, 2837SW only
	RU-6522	000-030-410	Converts 220 VAC to 200 VAC, 2837SW only
	RU-5466-1	000-030-453	Converts 440 VAC to 220 VAC, 2837SW only
Control Unit	RCU-016	-	Remote type, W/FP03-09860
Cable Assy	XH10P-W-5P-A L=10M	000-149-050	10 m
	XH10P-W-5P-A L=20M	000-149-051	20 m
	XH10P-W-5P-A L=30M	000-149-052	30 m
	S03-9-5	008-206-640	For external radar, 5 m, 8-8P
	S03-9-10	008-206-650	For external radar, 10 m, 8-8P
	S03-9-15	008-209-160	For external radar, 15 m, 8-8P
	DVI-D/D S-LINK 10M	000-150-200	10 m
LAN Cable Kit (with armor)	OP03-28900	000-082-658	FR-FTPC-CY 10 m
	OP03-28910	000-082-629	FR-FTPC-CY 20 m
	OP03-28920	000-082-660	FR-FTPC-CY 30 m
Accessories	FP03-09820	008-535-560	Hanger assy. for MU-201CE
	FP03-09830	008-536-020	Hanger assy. for MU-231CE
Hand Grip	FP03-09840	008-535-570	For monitor unit
Dust Cover	03-163-1201	100-307-260	For MU-201CE
	03-163-2101	100-307-270	For MU-231CE
Clamp Plate	OP03-182	008-535-620	For RCU-020
Flush Mount Kit	FP03-09870	008-535-630	For control unit RCU-016/020/015FEA
Coupling Pedestal	OP03-183	008-535-640	For RCU-020 & MU-201CE
	OP03-184	008-535-650	For RCU-020 & MU-231CE
Junction Box	RJB-001	-	For more than 100 m antenna cable
Switching Hub	HUB-100	-	See manual of HUB-100.
LAN Adapter	EC-1010		
B Adapter	EC-1020		
Rectifier	PR-62	000-013-484	For 100 VAC
		000-013-487	For 230 VAC
Cable assy	3COX-2P-6C	000-146-501	For external monitor (analog), 10 m
	DSUB9P-DSUB9P-L10.0M	000-150-676	Between Monitor/Processor unit
	MOD-Z072-100+	000-167-177-10	LAN cable (cross)
	MOD-Z072-020+	000-167-175-10	
	XH10P-DS-5P L=2.3M	000-150-001	For control unit
	XH10P-DS-5P L=20M	000-149-745	
	XH10P-DS-5P L=30M	000-149-746	

# SYSTEM CONFIGURATION

## FCR-2827W/2827W-D

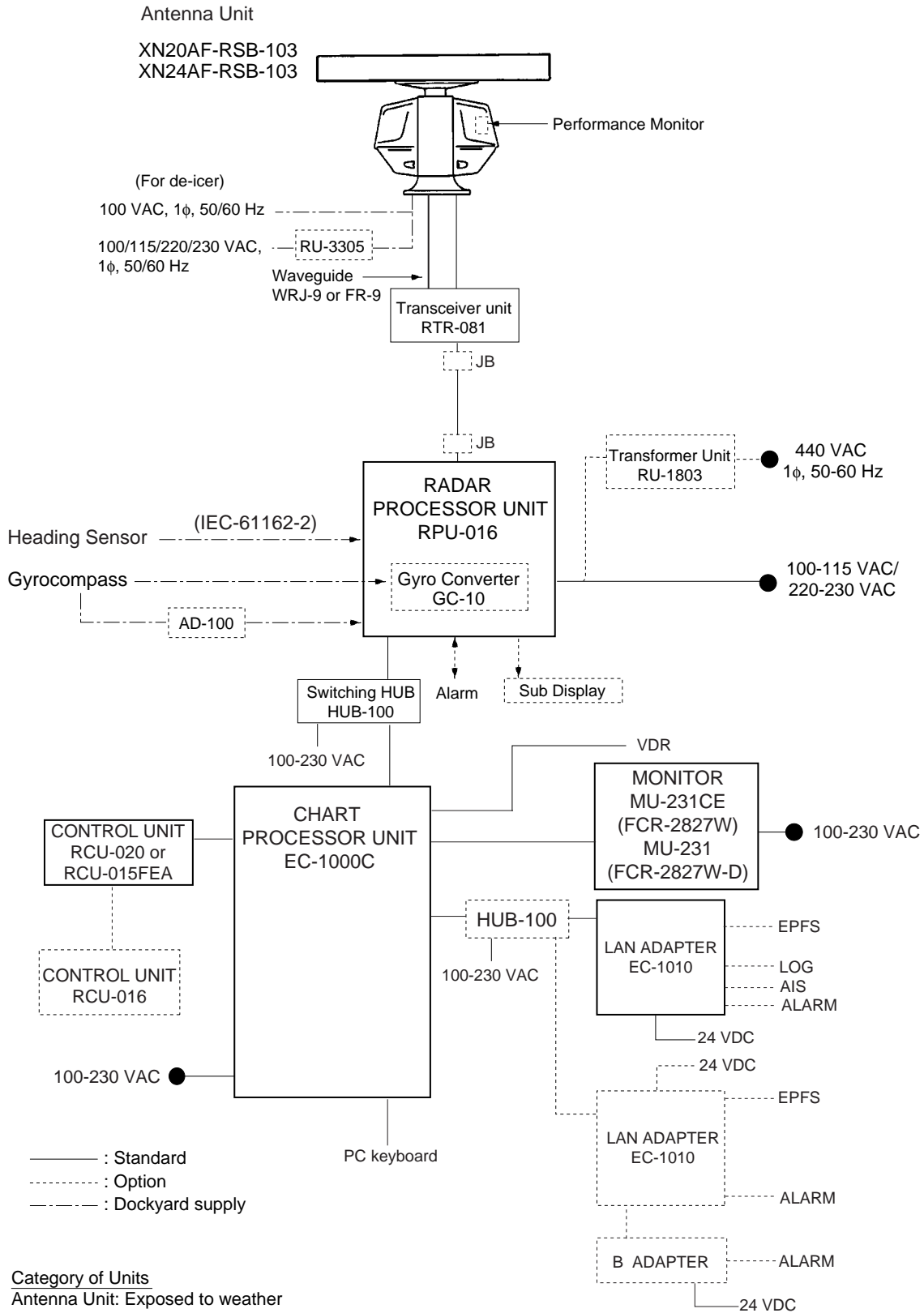



# FCR-2837SW/2837SW-D

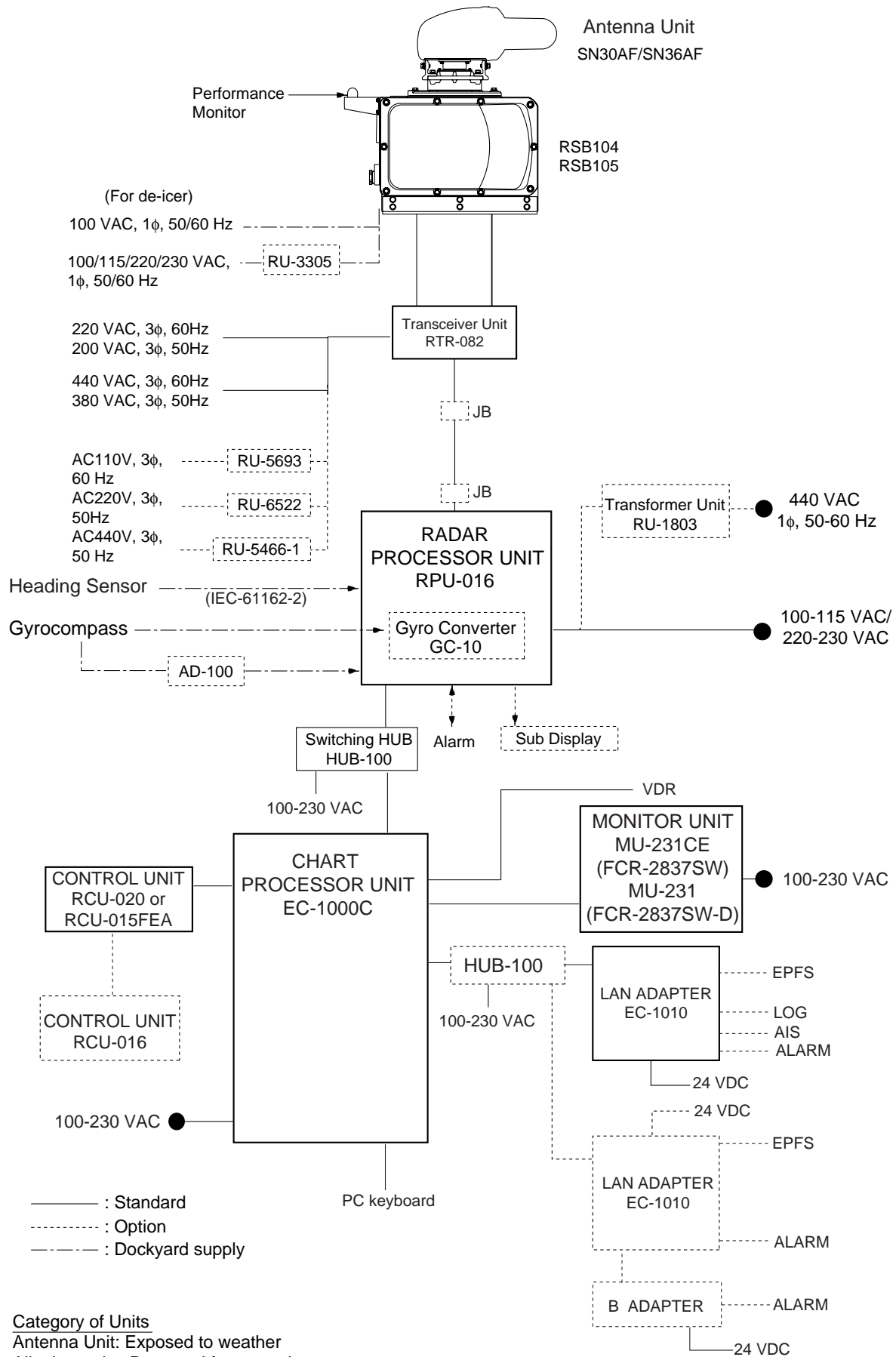

- 1) Connect the EPFS which is approved in accordance with the requirements of the IMO in resolution MSC.112(73) is used.
- 2) Connect the SDME which is approved in accordance with the requirements of the IMO in resolution MSC.96(72) is used.
- 3) Use the gyrocompass having an update rate that is adequate for the ship's rate of turn.

**About the category sticker**

This radar meets the requirements in IEC62388 (Marine navigation and radio communication equipment and systems – Shipborne radar – Performance requirements, method of testing and required test results).

Check the appropriate box on the sticker which is pre-attached on the processor unit., according to your radar's specification. Refer to the table shown below to confirm your category.

Category	Radar type	Antenna rotation speed
CAT 1C	FCR-2817, FCR-2817-D, FCR-2827, FCR-2827-D, FCR-2837S, FCR-2837S-D, FCR-2827W, FCR-2827W-D, FCR-2837SW, FCR-2837SW-D	Normal speed
CAT 1HC	FCR-2817, FCR-2817-D, FCR-2827, FCR-2827-D, FCR-2837S, FCR-2837S-D	HSC
CAT 2C	FCR-2117/BB, FCR-2117-D, FCR-2127/BB, FCR-2127-D, FCR-2137S/BB, FCR-2137S-D	Normal speed
CAT 2HC	FCR-2117/BB, FCR-2117-D, FCR-2127/BB, FCR-2127-D, FCR-2137S/BB, FCR-2137S-D	HSC

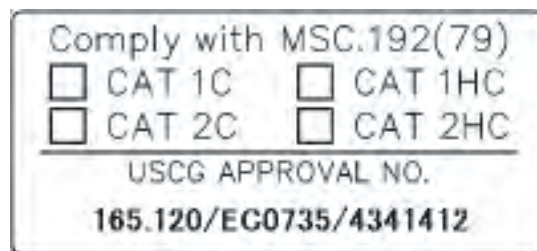

Sticker for Category

# 1. MOUNTING

## NOTICE

**Do not apply paint, anti-corrosive sealant or contact spray to coating or plastic parts of the equipment.**

Those items contain organic solvents that can damage coating and plastic parts, especially plastic connectors.

## 1.1 Antenna Unit

### Mounting considerations

- The antenna unit is generally installed either on top of the wheelhouse or on the radar mast, on a suitable platform. Locate the antenna unit in an elevated position to permit maximum target visibility.
- A line of sight from the antenna unit to the bow of the ship should hit the surface of the sea in not more than 500 m or twice the ship's length, depending which value is smaller, for all load and trim conditions.

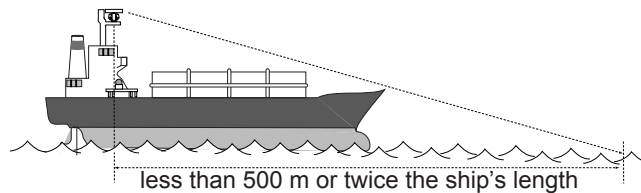

- Mount the antenna unit so that any blind sectors caused by objects (mast, etc.) are kept to a minimum. No blind sector should exist in arc of the horizon from right ahead to 22.5° aft of the beam to either side (see Figure 1 below). Also, individual blind sectors of more than 5°, or the total arc of both blind sectors of more than 20°, should not occur in the remaining arc (Figure 2). Note that any two blind sectors separated by 3° or less are regarded as one sector.

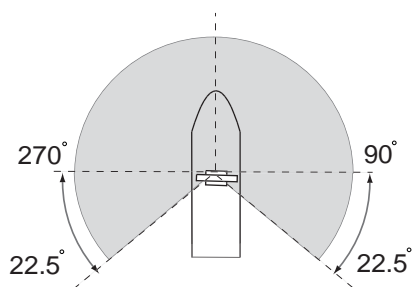

Figure 1

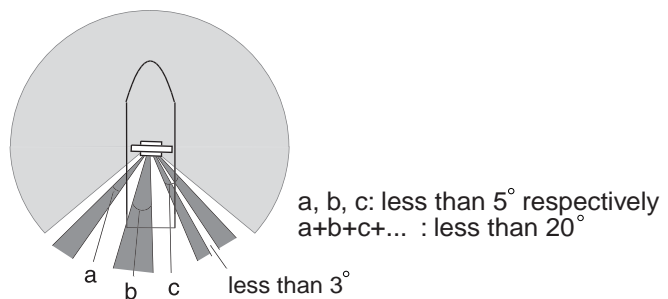
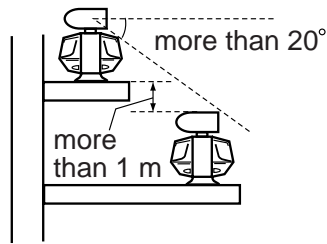

Figure 2

- Install the antenna unit safely away from interfering high-power energy sources and other transmitting radio antenna.

## 1. MOUNTING

- Keep the lower edge of the antenna unit (antenna radiator) above the safety rail by 500 mm or more.
- Two antenna units should be mounted as below:



- No funnel, mast or derrick should be within the vertical beamwidth of the antenna unit in the bow direction, especially zero degrees  $\pm 5^\circ$ , to prevent blind sectors and false echoes on the radar picture.
- It is rarely possible to place the antenna unit where a completely clear view in all directions is available. Thus, you should determine the angular width and relative bearing of any shadow sectors for their influence on the radar at the first opportunity after fitting.
- Locate a direction finder antenna clear of the antenna unit to prevent interference to the direction finder. A separation of more than two meters is recommended.
- A magnetic compass will be affected if the antenna unit is placed too close to the magnetic compass. Observe the compass safe distances on page ii to prevent deviation of the magnetic compass.
- Do not paint the radiator aperture, to ensure proper emission of the radar waves.
- The antenna base is made of cast aluminum. To prevent electrolytic corrosion of the antenna base, use the seal washers and corrosion-proof rubber mat and ground the unit with the ground wire (supplied).
- Deposits and fumes from a funnel or other exhaust vent can adversely affect the aerial performance and hot gases may distort the radiator portion. The antenna unit must not be mounted where the temperature is more than 70°C.
- Leave sufficient space around the unit for maintenance and servicing. See the antenna unit outline drawing for recommended maintenance space.

### 1.1.1 FCR-2827W/2827W-D antenna unit

#### Assembling the antenna unit

The antenna unit consists of the antenna radiator and the antenna unit chassis, and they are packed separately. Fasten the antenna radiator to the antenna unit chassis as follows:

1. Attach two guide pins (supplied as installation materials) to the underside of the antenna radiator.
2. Remove the waveguide cap from the radiator bracket. The cap may be discarded.
3. Coat the waveguide flange with anticorrosive sealant as shown below.

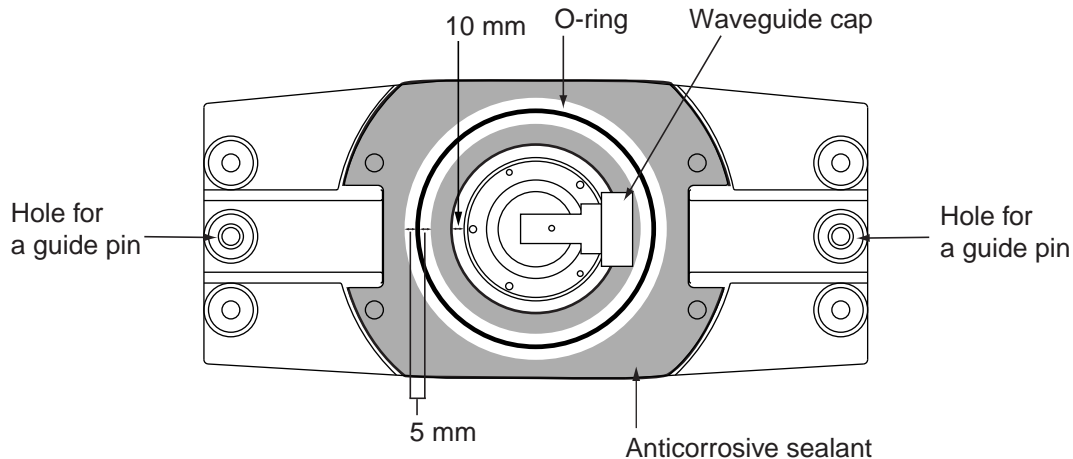

#### *Coating the waveguide flange with anticorrosive sealant*

4. Coat fixing holes for the antenna radiator with anticorrosive sealant.
5. Grease the O-ring and set it to the O-ring groove of the radiator flange.
6. Set the antenna radiator to the radiator bracket.
7. Coat hex bolts M8 x 40 with anticorrosive sealant and use them to loosely fasten the antenna radiator to the antenna unit chassis.
8. Remove two guide pins (inserted at step 1), and then tighten fixing bolts.

#### **CAUTION**

**Be sure to remove the guide pins.**

Injury may result if the guide pins loosen and fall.

## 1. MOUNTING

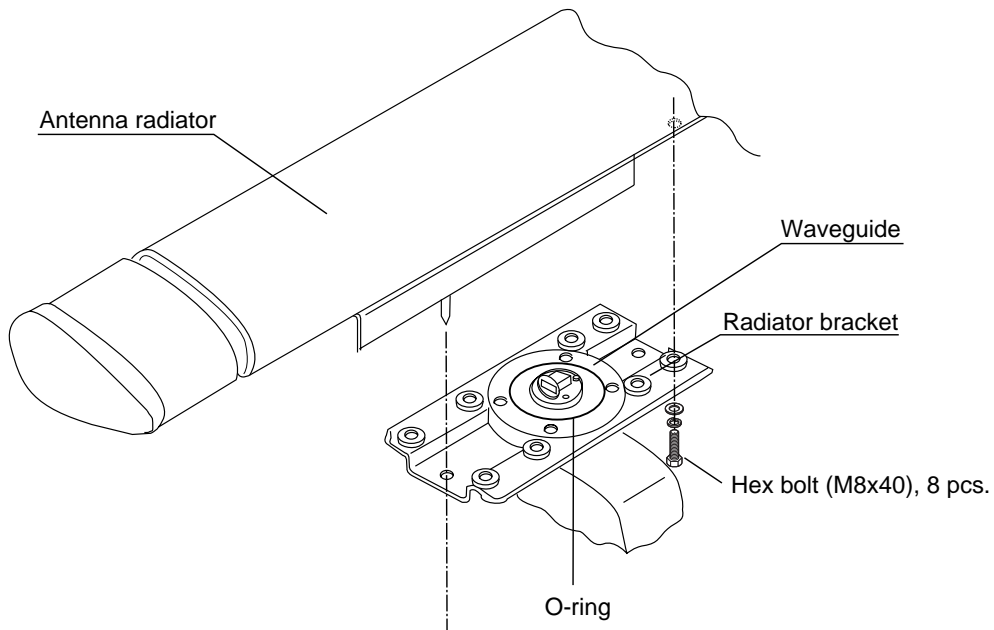

*Fastening the radiator to the radiator bracket*

### **Coating the waveguide flange with silicone sealant**

1. Do not coat O-ring with silicone sealant; use grease.
2. Clean the surface of the waveguide flange, if necessary. Evenly coat the waveguide flange with silicone sealant as shown in the illustration below.

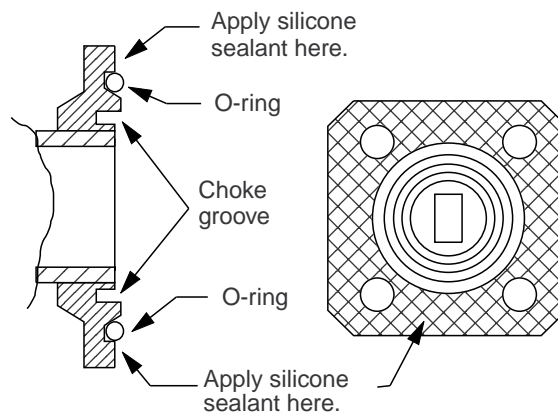

Evenly coat the waveguide flange with silicone sealant. Apply sealant sparingly; it leaks out slightly when the fixing bolts are tightened. Be sure no sealant contacts the choke groove and waveguide.

*Coating the waveguide flange with silicone sealant*

### Fastening the antenna unit to the mounting platform

The antenna unit may be assembled before hoisting it to the mounting platform. However, do not lift the antenna unit by the radiator. Always hold the unit by its housing. When using a crane or hoist, lift the unit by the hoist rings which should be fastened to the lifting fixture of the antenna housing.

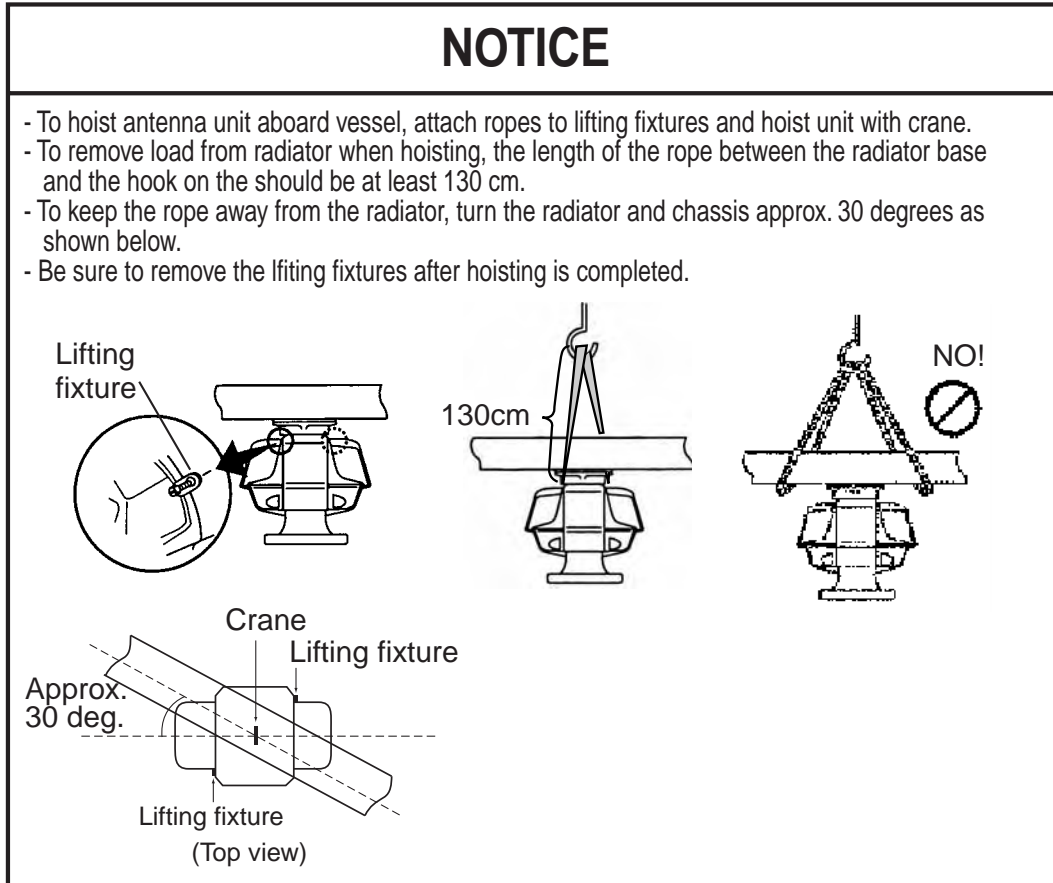

1. Construct a suitable mounting platform referring to the outline drawing at the end of this manual.
2. Drill four mounting holes of 15 mm diameter and one cable entry hole of about 50 mm diameter in the mounting platform.
3. Lay the rubber mat (supplied) on the mounting platform.
4. Place the antenna unit on the rubber mat, orienting the unit so the antenna switch on it faces the ship's bow.

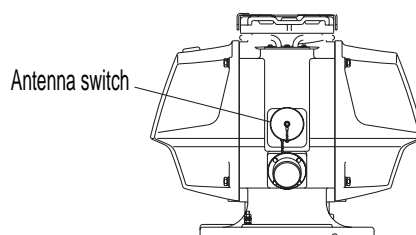

*Antenna unit, front view*

5. Fasten the antenna unit to the mounting platform with M12x60 hex bolts, nuts, flat washers and seal washers.

## 1. MOUNTING

6. Using hex bolt (M6x25), nut (M6) and flat washer (M6), establish the ground system on the mounting platform as shown below. The location should be within 340 mm of the ground terminal on the antenna unit. Connect the ground wire (RW-4747, 340 mm, supplied) between the grounding point and ground terminal on the antenna unit. Coat the entire ground system with silicone sealant (supplied).

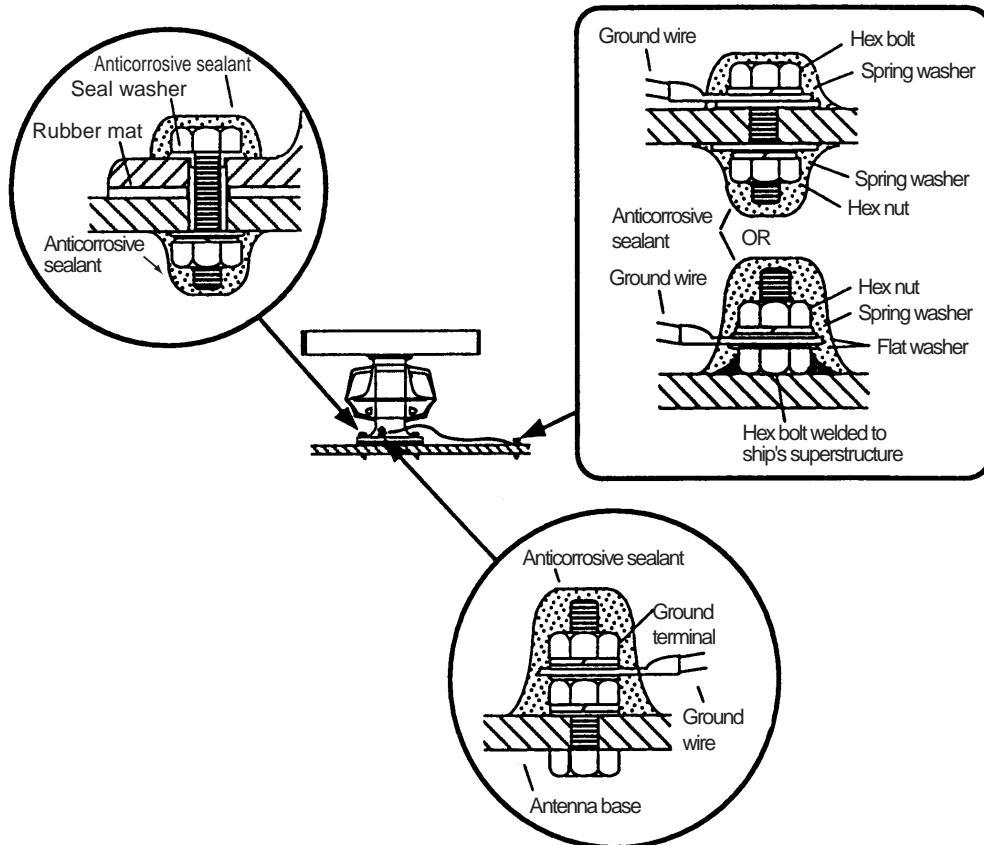

*How to mount the antenna unit*



### 1.1.2 FAR 2837SW/2837SW-D antenna unit

#### Installation precaution for S-band antenna unit

If an S-band antenna unit is mounted near the end of a platform to provide sufficient rotation clearance for the radiator, the antenna unit, because of its weight, swings up and down by ship's vibration and rolling, exerting excessive levels of stress at the base of the radiator, which can damage the radiator. To prevent this, relocate the antenna unit, or if relocation is not possible, reinforce the platform.

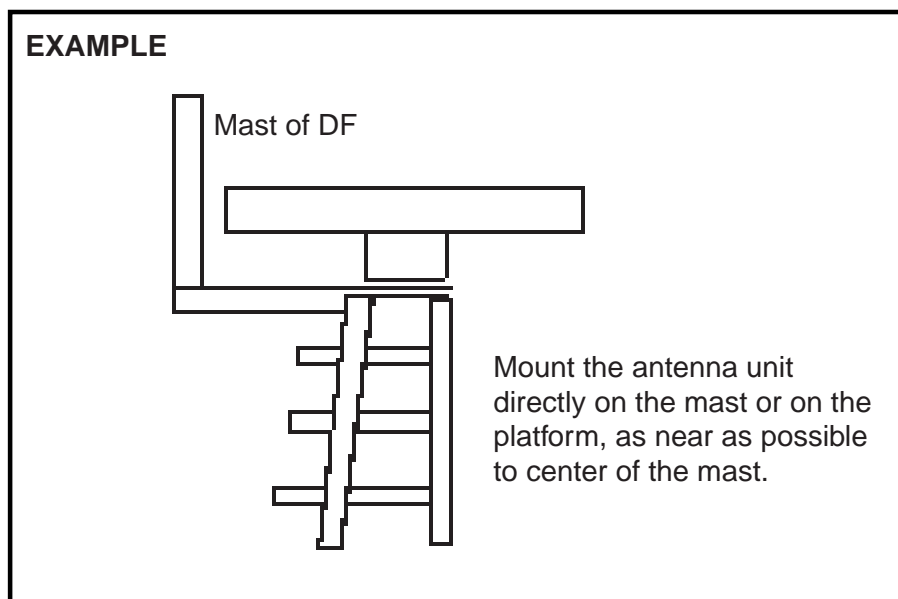
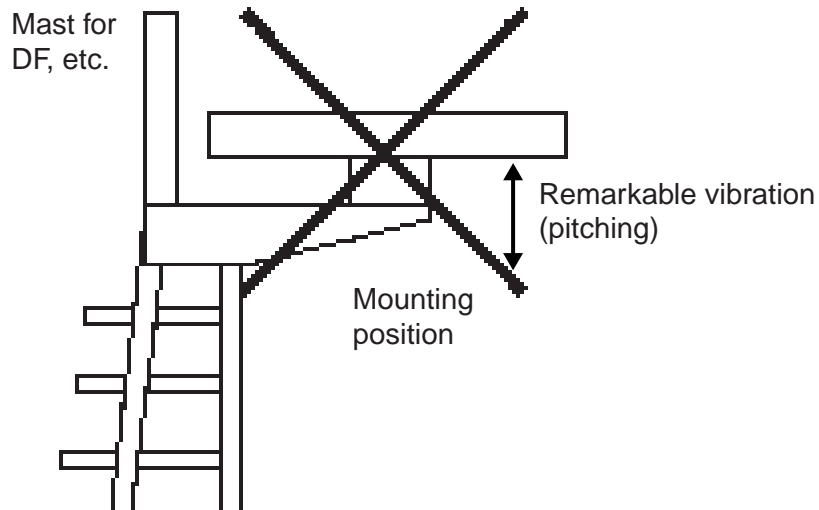

*Mounting of S-band antenna unit*

## 1. MOUNTING

### Antenna unit assembling

The antenna radiator and the antenna housing are shipped in separate packages. Assemble them as below. The antenna unit may be assembled before hoisting it to the mounting platform. However, do not lift the antenna unit by the radiator.

#### Antenna unit assembling procedure

1. Screw the guide pins (2 pcs.) in the radiator.
2. Remove the protective cap from the choke guide.
3. Grease O-ring and set it to the groove of the choke guide.
4. Place the radiator on the radiator bracket. (Radiator direction is shown by the logo on the bracket. If reversely oriented the radiator cannot be set to the bracket.)
5. Loosely fix the radiator to the radiator bracket with hex. bolts (M10x25), spring washers and flat washers.
6. Remove the guides pins and tighten hex. bolts.

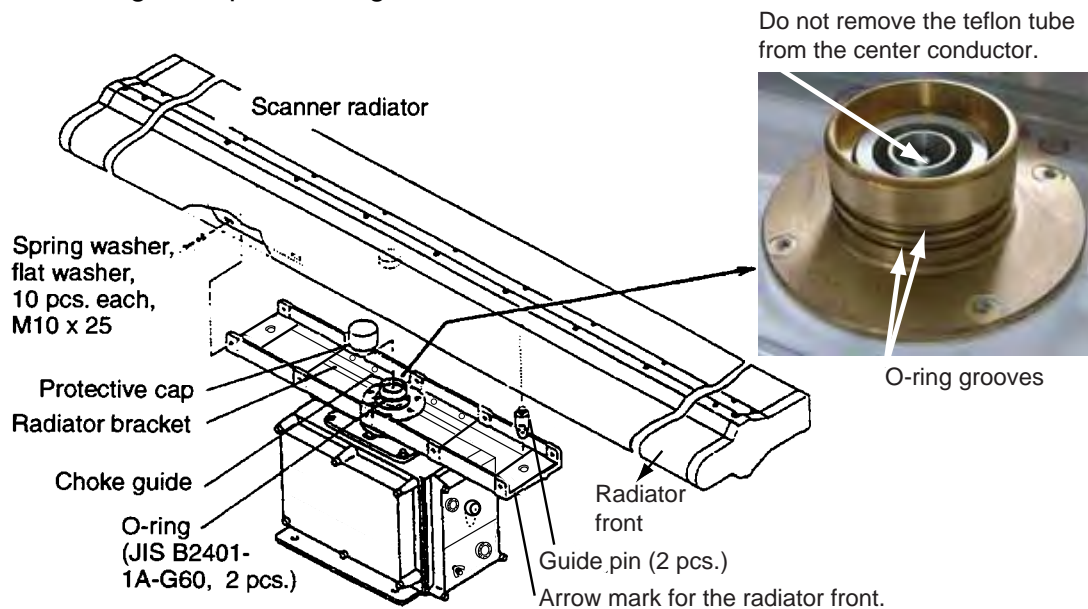

#### *Assembling the radiator bracket*

### **⚠ CAUTION**

**Be sure to remove the guide pins.**

Injury may result if the guide pins loosen and fall.

**How to lift antenna unit**

1. Fix the antenna radiator to the antenna unit chassis.
2. Attach the lifting fixtures and collars as shown in figures below.
3. Position the radiator as shown in figure below and arrange the ropes A and B.

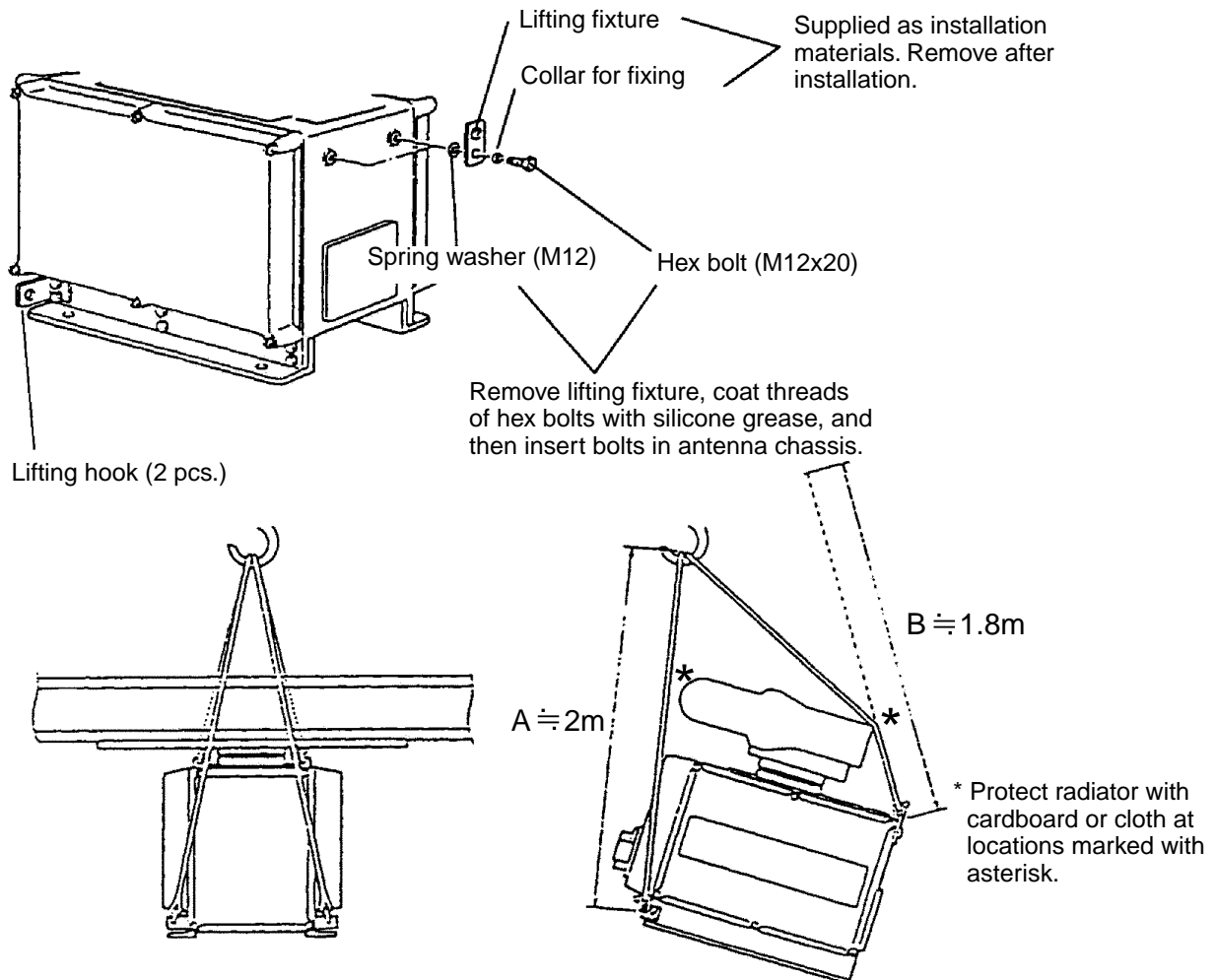

*Attachment of lifting fixtures, collar and lopes*

## 1. MOUNTING

### **Fastening the antenna unit to the mounting platform**

See the figure on the next page for antenna unit mounting.

1. Referring to the antenna outline drawing, drill four bolt holes (15 mm diameter) in the radar mast platform or the deck.
  - a) The diameter of the mast for fixing the antenna unit platform must be over 15 mm.
  - b) The thickness of the antenna unit platform must be over 15 mm.
  - c) The reinforcement rib must be installed diagonally as shown below.

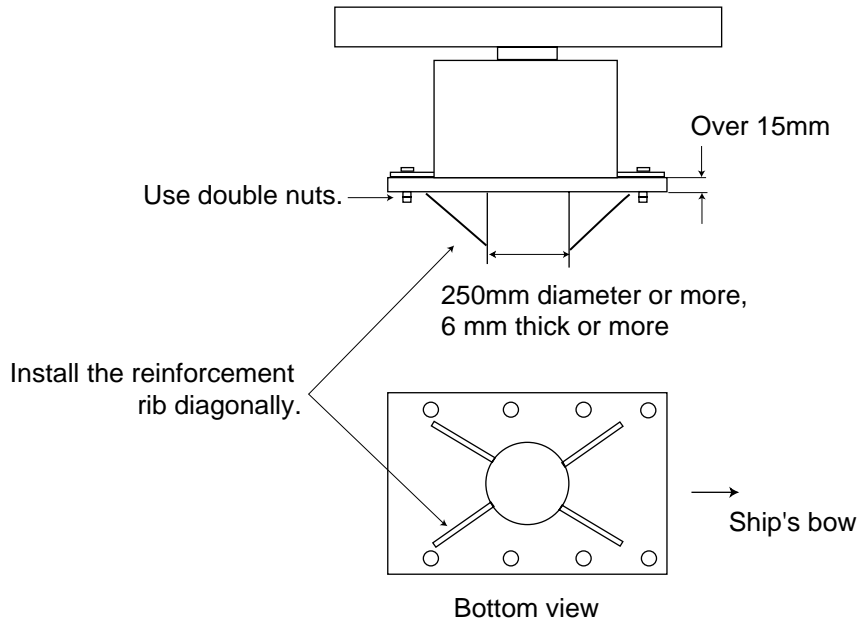

*Installation of reinforcement ribs*

2. Place the corrosion-proof rubber mat (supplied) on the mounting platform.
3. Hoist the antenna unit as shown on page 1-9 and place it on the rubber mat. Orient the cable gland toward the ship's stern (or port, starboard). Remove the lifting fixtures and collars.
4. Fix the antenna base to the mounting platform with four M12x70 hex. bolts, nuts, washers and seal washers (supplied).
5. Arrange the grounding terminal at the nearest grounding spot with the M6x25 hex. bolt, nut and washers (supplied). Then, fix a ground wire (RW-4747, 340 mm) to the terminal.
6. Connect the other end of the ground wire to the earth terminal of the antenna unit.
7. Coat earth terminal and fixing bolts on the antenna unit with silicone sealant (supplied).

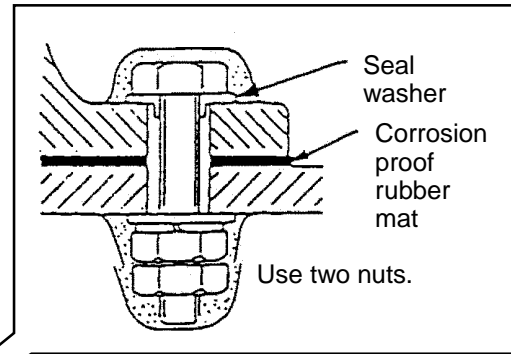
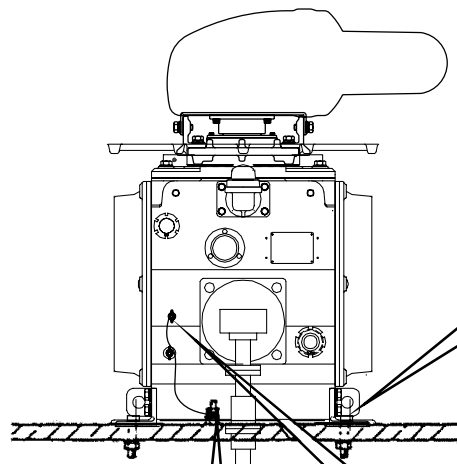

Set corrosion-proof rubber mat, bolt antenna unit to mounting location, and coat exposed hardware with silicone sealant.

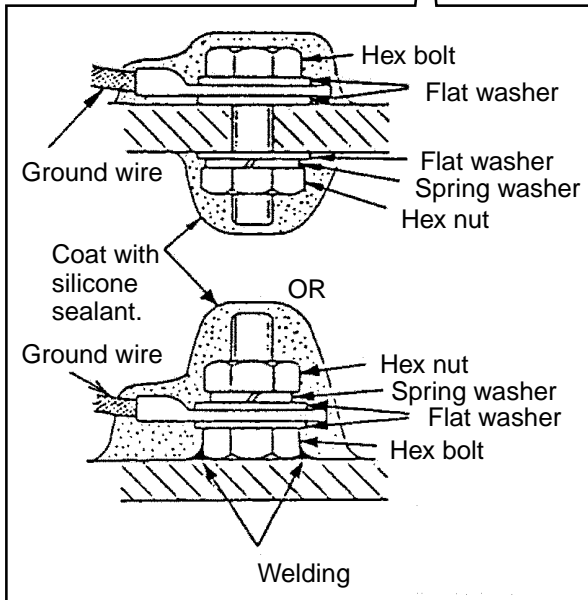

Arrange ground terminal as close as possible to antenna unit.

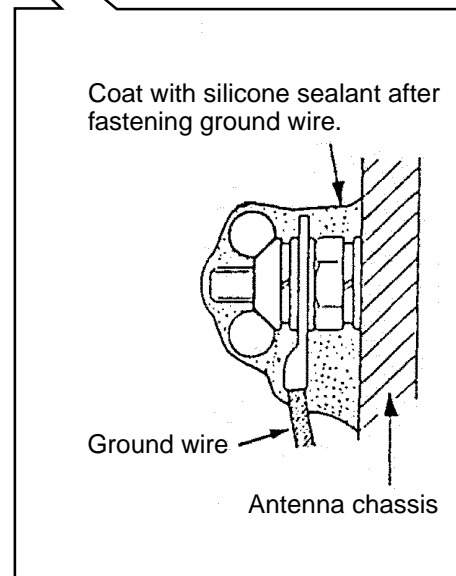

Ground terminal provided on antenna base.

*Mounting of antenna unit*

## 1. MOUNTING

### 1.2 Monitor Unit

The monitor unit can be flush mounted in a console panel, or mounted on a desktop using the optional accessories. For MU-231, see its Operator's Manual.

When selecting a mounting location, keep in mind the following points:

- Select a location where the monitor unit can be viewed conveniently and where the screen can be viewed while facing towards the bow.
- Locate the unit out of direct sunlight and away from heat sources because of heat that can build up inside the cabinet.
- The optimal viewing distances for the radar display units are: MU-231CE: 1200 mm. Select a suitable mounting location considering the applicable distance.
- Locate the equipment away from places subject to water splash and rain.
- Leave sufficient space on the sides and rear of the unit to facilitate maintenance.
- A magnetic compass will be affected if the monitor unit is placed too close to the magnetic compass. Observe the compass safe distances on page ii to prevent deviation of a magnetic compass.

### Mounting procedure

#### Flush mounting

Follow the procedure below to mount the monitor unit in a console panel.

1. Make cutout in mounting location referring to the outline drawing shown below.
2. Insert the monitor unit to the hole and fix it with four tapping screws (6x30).
3. Attach panel hooks near the fixing holes (upper part). See next page. These are used to pull out the monitor unit from a console panel for servicing.
4. Attach four panel covers to the fixing holes.

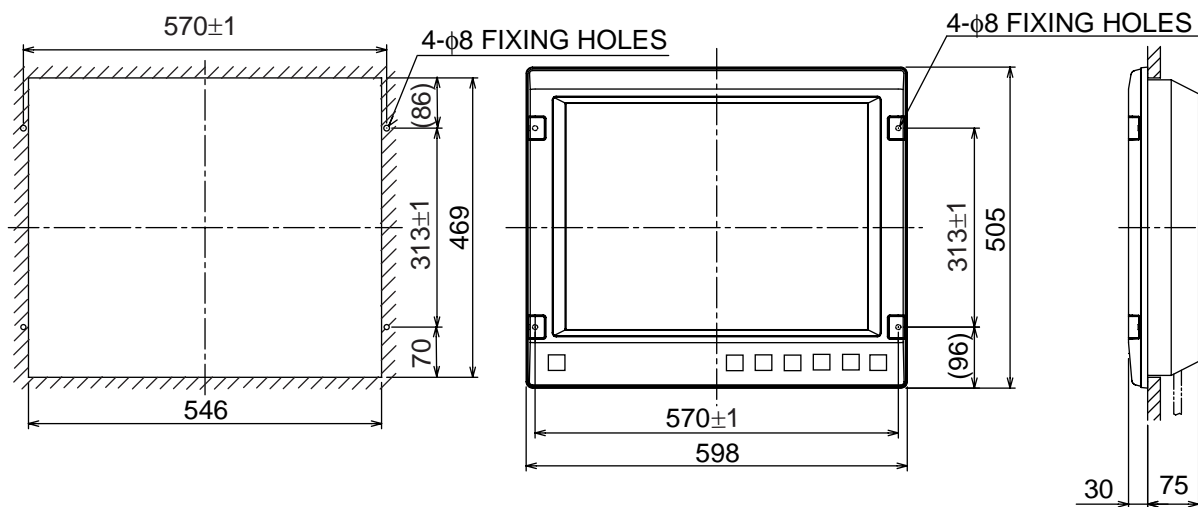

Monitor unit MU-231CE

*Flush mounting of monitor unit*

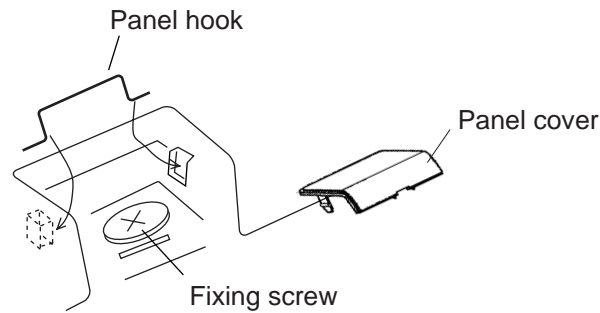

*Attaching panel hook and panel cover*

**Note:** If you need to remove the monitor unit from the mounting panel, remove the four panel covers with your fingernail and use two panel hooks supplied as accessories to lift the monitor unit.

### **Desktop mounting**

Use the optional accessories to mount the monitor unit on a desktop.

- For MU-231CE: FP03-09830 (Code No.: 008-536-020)

#### Contents of FP03-09820/09830

Name	Type	Code No.	Qty	Remarks
Hanger L	03-163-1111	100-305-141	1	
Hanger R	03-163-1112	100-305-181	1	
Hanger stay	03-163-2071	100-305-371	1	For MU-231CE
Hole plug	CP-30-HP-13	000-160-074-10	2	
Plastic rivet	KB-13 Rivet Black	000-570-276-10	4	
Hex. bolt	M6x25	000-162-949-10	4	
Hex. bolt	M10x30	000-162-884-10	2	
Spring washer	M10	000-864-261	2	
Flat washer	M10	000-864-131	2	

1. Assemble two hangers and hanger stay with two hex bolts (M10x30), flat washers and spring washers and cover each hex bolt with hole plug.
2. Fix the above assembly to the mounting location with four hex bolts (M12, dockyard supply).
3. Fasten the monitor unit to the mounting hanger assembly with four hex bolt (M6x25, supplied).
4. Cover each hex bolts with panel cover.
5. Cover each holes for hand grip on the hangers with plastic rivets (4 pcs).

# 1. MOUNTING

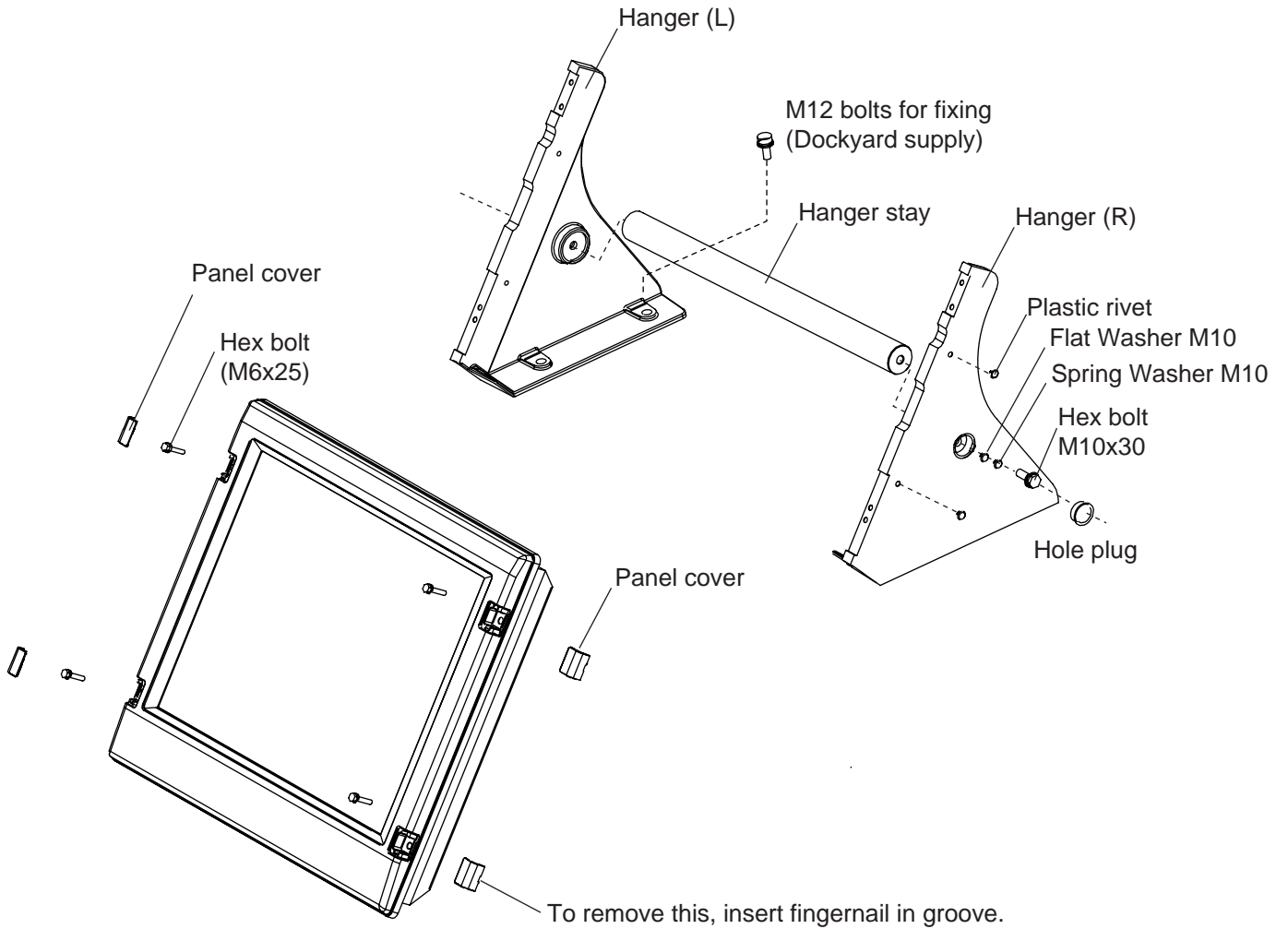

## Monitor Unit

- The hand grip is optionally available for the desktop mounting monitor unit.

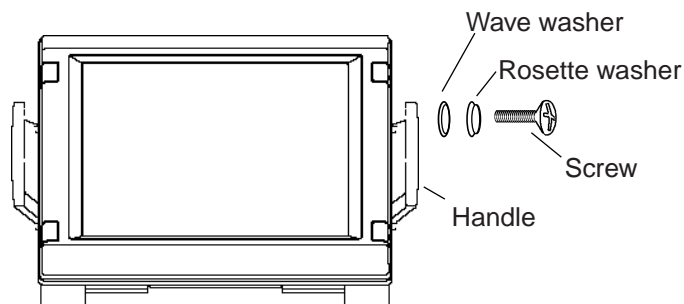



## 1.3 Control Unit

The control unit may be mounted on a desktop, with or without the KB fixing metal (supplied), which mounts the control unit at an angle.

### Mounting considerations

When selecting a mounting location, keep in mind the following points:

- Select a location where the control unit can be operated conveniently.
- Locate the unit away from heat sources because of heat that can build up inside the cabinet.
- Locate the equipment away from places subject to water splash and rain.
- Determine the mounting location considering the length of the signal cable between the control unit and the processor unit. (The 10m signal cable is attached to the control unit).
- A magnetic compass will be affected if the control unit is placed too close to the magnetic compass. Observe the compass safe distances on page ii to prevent deviation of a magnetic compass.

### Fixing with KB fixing plate

1. Fix the KB fixing plate to the bottom of the control unit.
2. Attach cushions (three for RCU-020, two for RCU-015FEA/016) to the bottom of the control unit as shown below.
3. Fix it to a desired location with self-tapping screws (local supply).

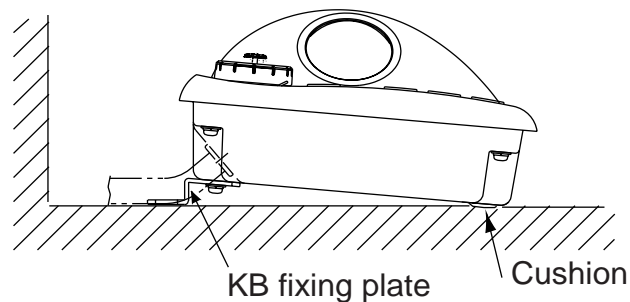

*Side view for RCU-020/015FEA/016*

## 1. MOUNTING

### Fixing without KB fixing metal

1. Drill four mounting holes of 5 mm diameter referring to the outline drawing at the back of this manual.
2. Fix the control unit with four screws (M4) from under side of the desktop. (The M4 screws with a sufficient length for the thickness of the desktop should be provided locally.)

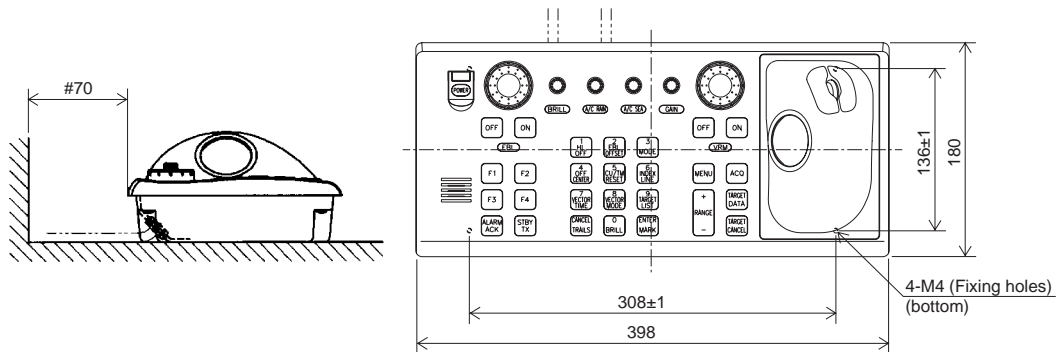

*Control Unit RCU-020*

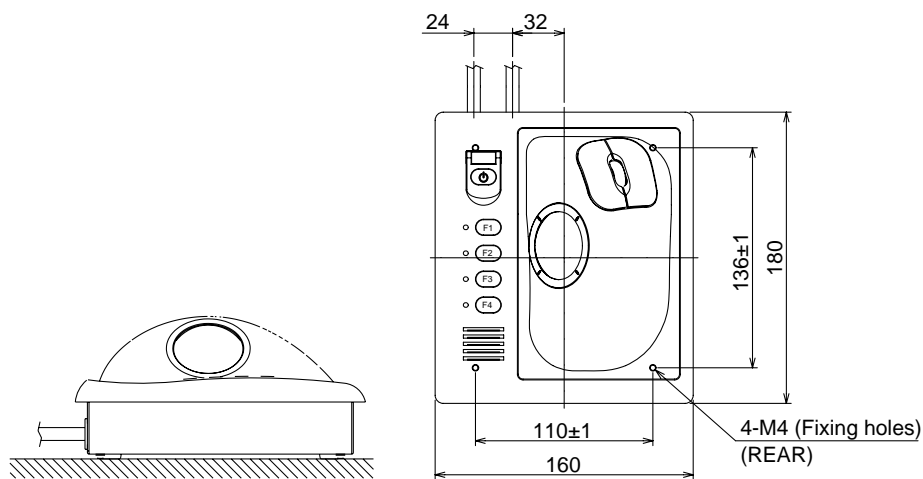

*RCU-015FEA/016*

### Flush mounting

Use the optional flush mount kit FP03-09870 to mount the control unit RCU-020, RCU-015FEA and/or RCU016 to a console panel.

Name: Flush mount kit

Type: FP03-09870

Code No.: 008-535-630

No.	Name	Type	Code No.	Qty
1	Mount plate	03-163-7531	100-306-261	4
2	Hex nut	M5	000-863-108	4
3	Wing screw	M5x40	000-162-682-10	4
4	Pan head screw	M4x12	000-163-192-10	4

1. Prepare a cutout in the mounting location as shown in the figure below.

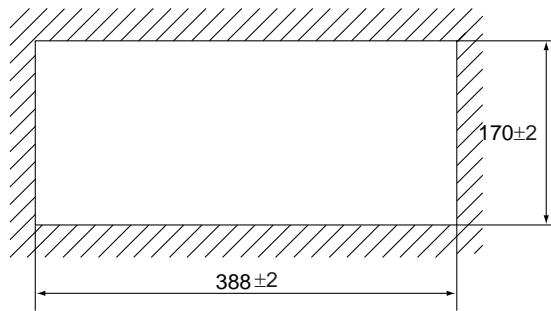

For RCU-020

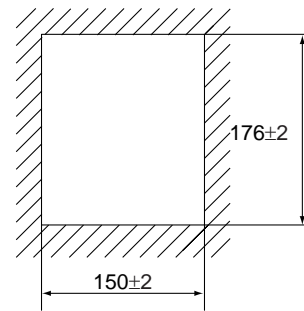

For RCU-015FEA and RCU-016

2. Set the control unit to the cutout.
3. Attach the mounting plate to the control unit with four screws from the rear side.
4. Screw the wing screw to each mounting plate and then insert hex bolt to each wing screw.
5. Fasten each wing screw and then fasten the hex nuts as shown in the figure below.

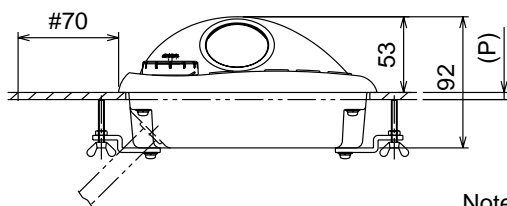

RCU-020

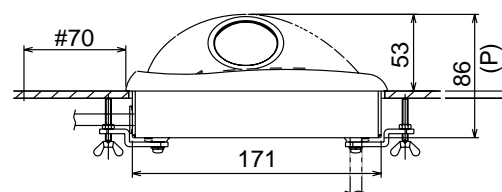

RCU-015FEA/RCU-016

Note:  $P \leq 10$

**To connect RCU-016 in series with RCU-020**

1. Pass the cable derived from RCU-016.

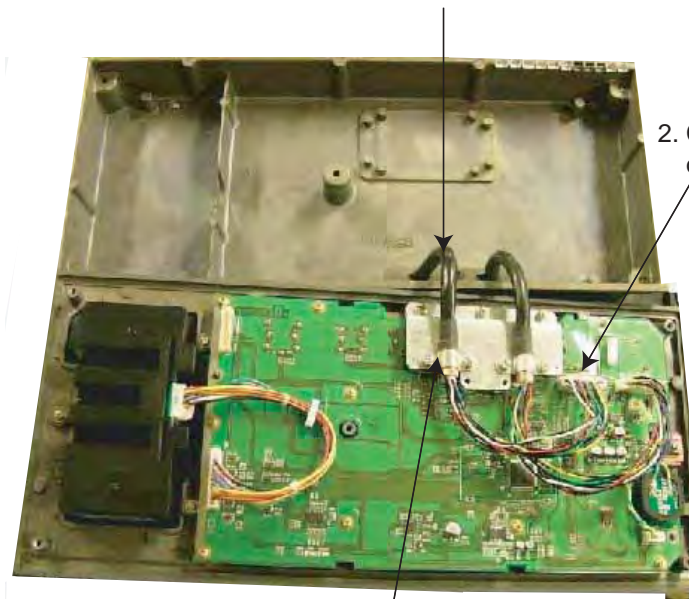

2. Connect the connector of the cable to J502.

3. Clamp the copper part of the cable with the cable clamp.

*Inside of RCU-020*

## 1. MOUNTING

### To change the cable entry

To change the cable entry from the side (default) to the bottom, modify the unit as shown below.

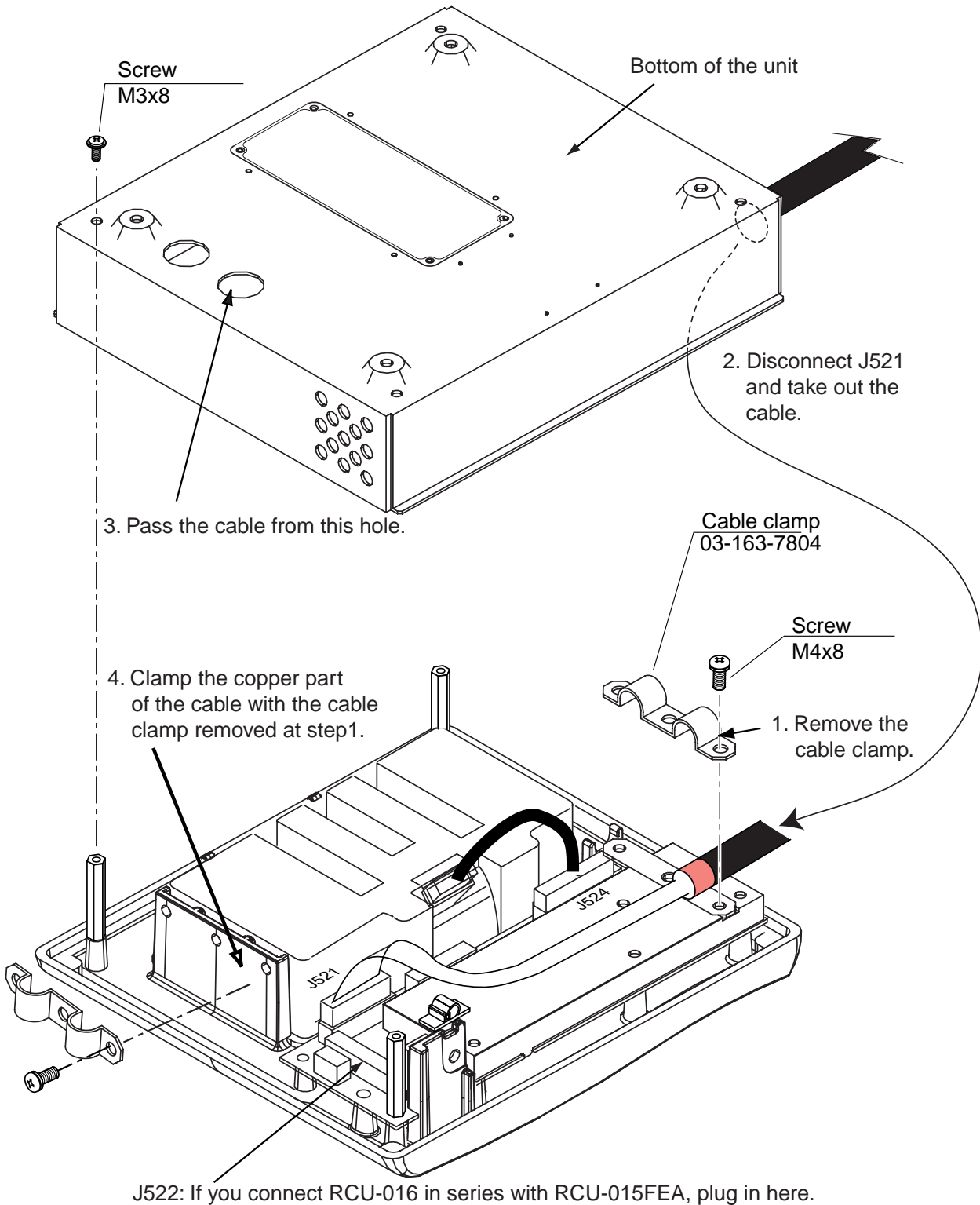

*RCU-015FEA/016: Changing cable entry*

## 1.4 Radar Processor Unit

### Mounting considerations

When selecting a mounting location, keep in mind the following points:

- Locate the processor unit away from heat sources because of heat that can build up inside the cabinet.
- Locate the equipment away from places subject to water splash and rain.
- Leave sufficient space at the sides and rear of the unit to facilitate maintenance.
- A magnetic compass will be affected if the processor unit is placed too close to the magnetic compass. Observe the compass safe distances on page ii to prevent deviation of a magnetic compass.

### Mounting procedure

1. Fix the unit with four M6 bolts, or self-tapping screws.

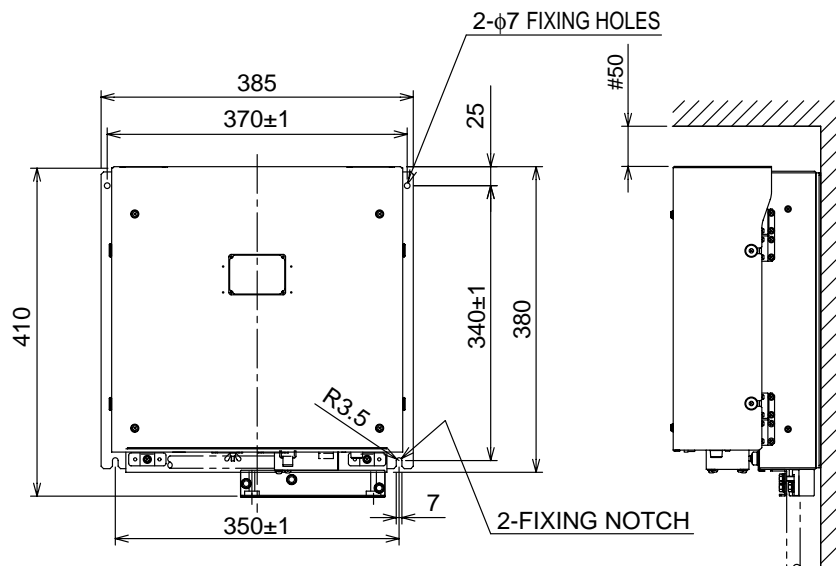

*Floor mounting or bulkhead mounting*

**Note:** If you fix the unit, cable entry upside, never remove the screw M3x10 that joints the upper case assy. and lower case assy. of the processor unit.

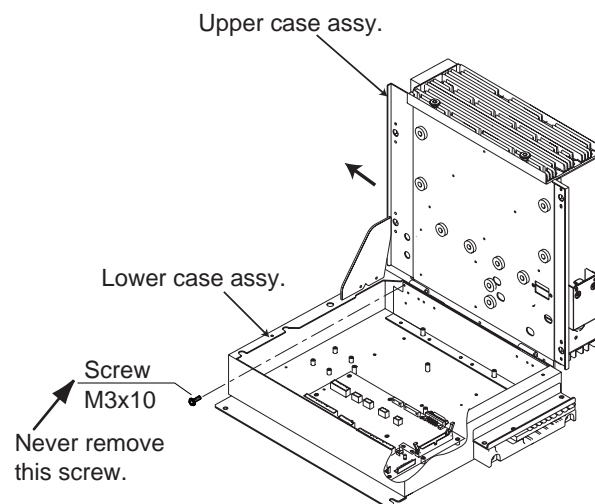

*Processor unit*

## 1.5 Transceiver Unit

The transceiver unit is designed for bulkhead mounting, and may be mounted in any dry, well-ventilated place. Ensure the mounting location is strong enough to support the weight of the unit under the continued shock and vibration normally encountered onboard. The transceiver must not be installed in close proximity of a magnetic compass; observe the compass safe distances on page ii.

Fix the unit to bulkhead with bolts (RTR-081: M6, 4 pcs., RTR-082: M8, 6 pcs.). Run a ground wire (8 mm<sup>2</sup>) between the ship's body and the transceiver unit, using the lug supplied to make the connection at the earth stud on the transceiver unit. Keep the length of the ground wire as short as possible.

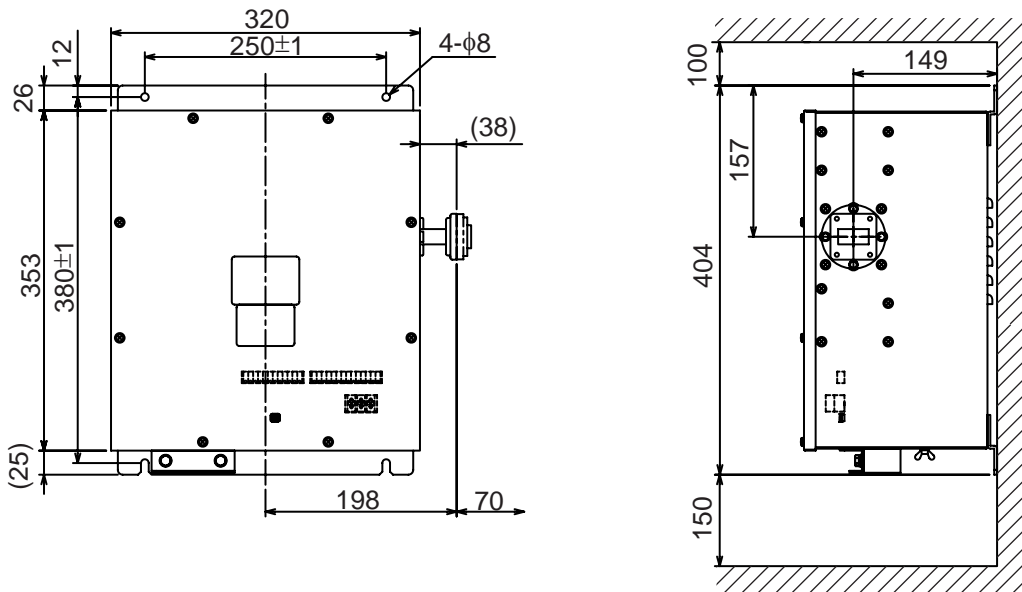

*Transceiver unit RTR-081 (for FAR-2827W)*

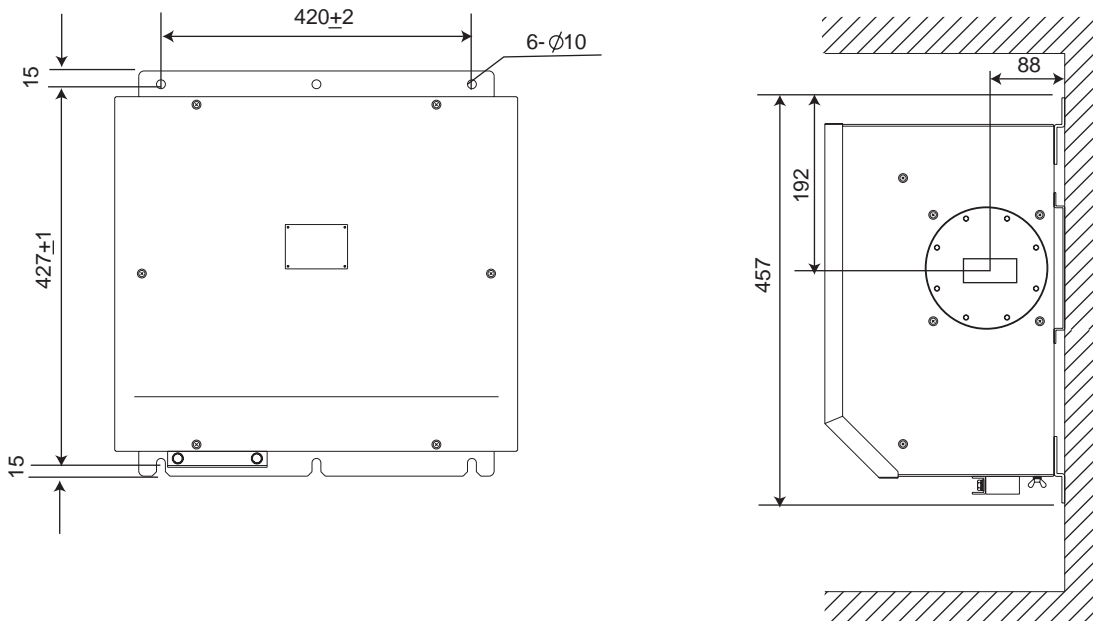

*Transceiver unit RTR-082 (for FAR-2837SW)*

## 1.6 Chart Processor Unit

### Mounting considerations

When selecting a mounting location, keep in mind the following points:

- Locate the processor unit away from heat sources because of heat that can build up inside the cabinet.
- The vibration at the mounting location should be minimum.
- Locate the equipment away from places subject to water splash and rain.
- Leave sufficient space at the sides and rear of the unit to facilitate maintenance.
- A magnetic compass will be affected if the processor unit is placed too close to the magnetic compass. Observe the compass safe distances on page ii to prevent deviation of a magnetic compass.

### Mounting procedure

1. Attach two mounting plates to the processor unit with 14 screws (M4x8, supplied).
2. Fix the unit with six M6 bolts, or self-tapping screws (local supply).

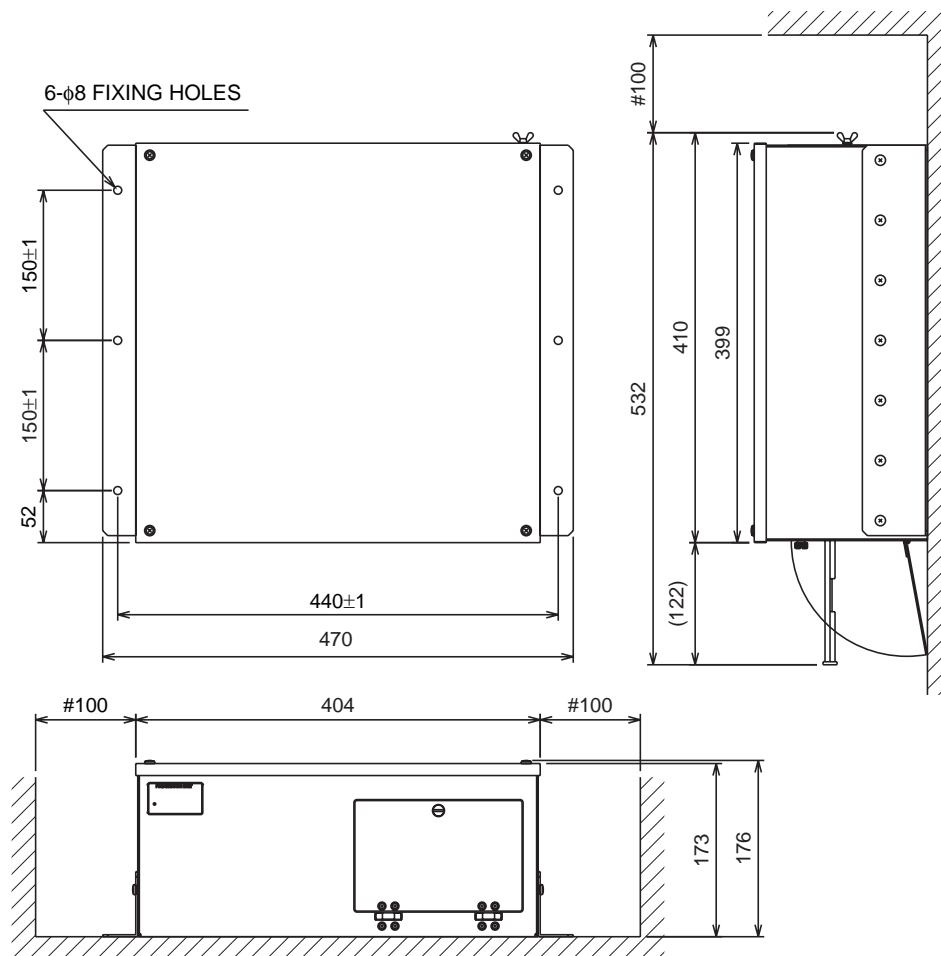

## 1.7 LAN Adapter/B Adapter

### Mounting considerations

When selecting a mounting location, keep in mind the following points:

- Locate the adapter away from heat sources because of heat that can build up inside the cabinet.
- The vibration should be minimal.
- Locate the equipment away from places subject to water splash and rain.
- Leave sufficient space at the sides and rear of the unit to facilitate maintenance.
- A magnetic compass will be affected if the adapter is placed too close to the magnetic compass. Observe the compass safe distances on page ii to prevent deviation of a magnetic compass.

### LAN adapter/B adapter

1. Unfasten a pan head screw to remove the cover from the LAN adapter/B adapter.
2. Fasten four self-tapping screws (M3) to fix the adapter to the mounting location.
3. Reattach the cover.

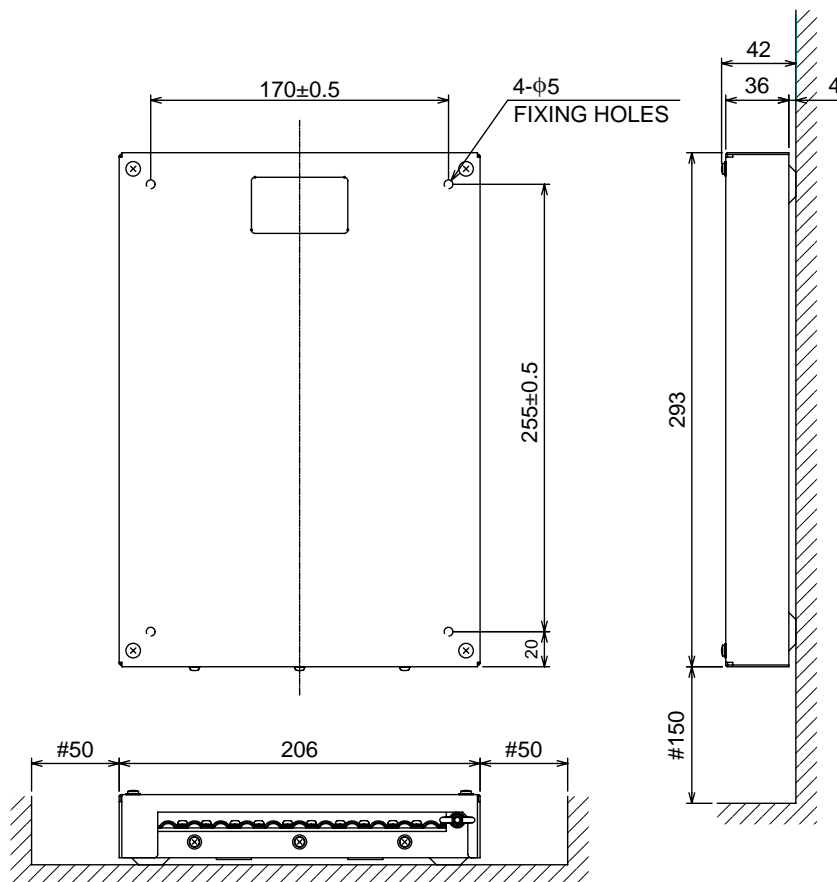



# 2. WIRING

## 2.1 Interconnection

### Wiring consideration

To lessen the chance of picking up electrical interference, avoid where possible routing the signal cable near other onboard electrical equipment (radars, transmitting radio antennas, etc.) Also avoid running the cable in parallel with power cables. When crossing with other cable, the angle should be 90° to minimize the magnetic field coupling.

The signal cable between the antenna and processor units is available in lengths of 15 m, 30 m, 40 m and 50 m. Whatever length is used, it must be unbroken; namely, no splicing allowed. Use the signal cable as short as possible to minimize attenuation of the signal.

The radar should be connected to an emergency power source, as required by SOLAS II-1. **FCR-2827W/2827W-D**

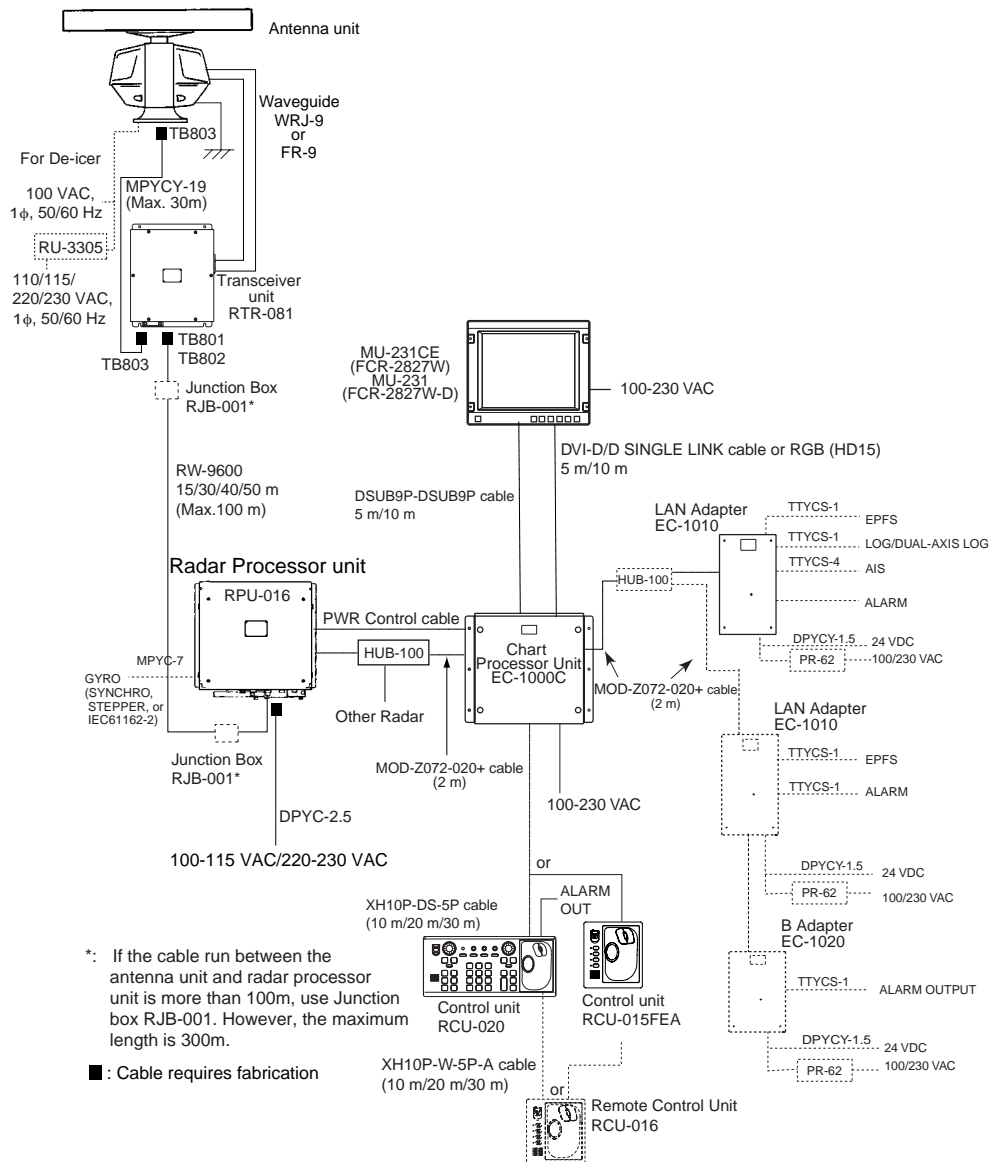

Standard Interconnection (FCR-2827W/2827W-D)

## 2. WIRING

### **FCR-2837SW/2837SW-D**

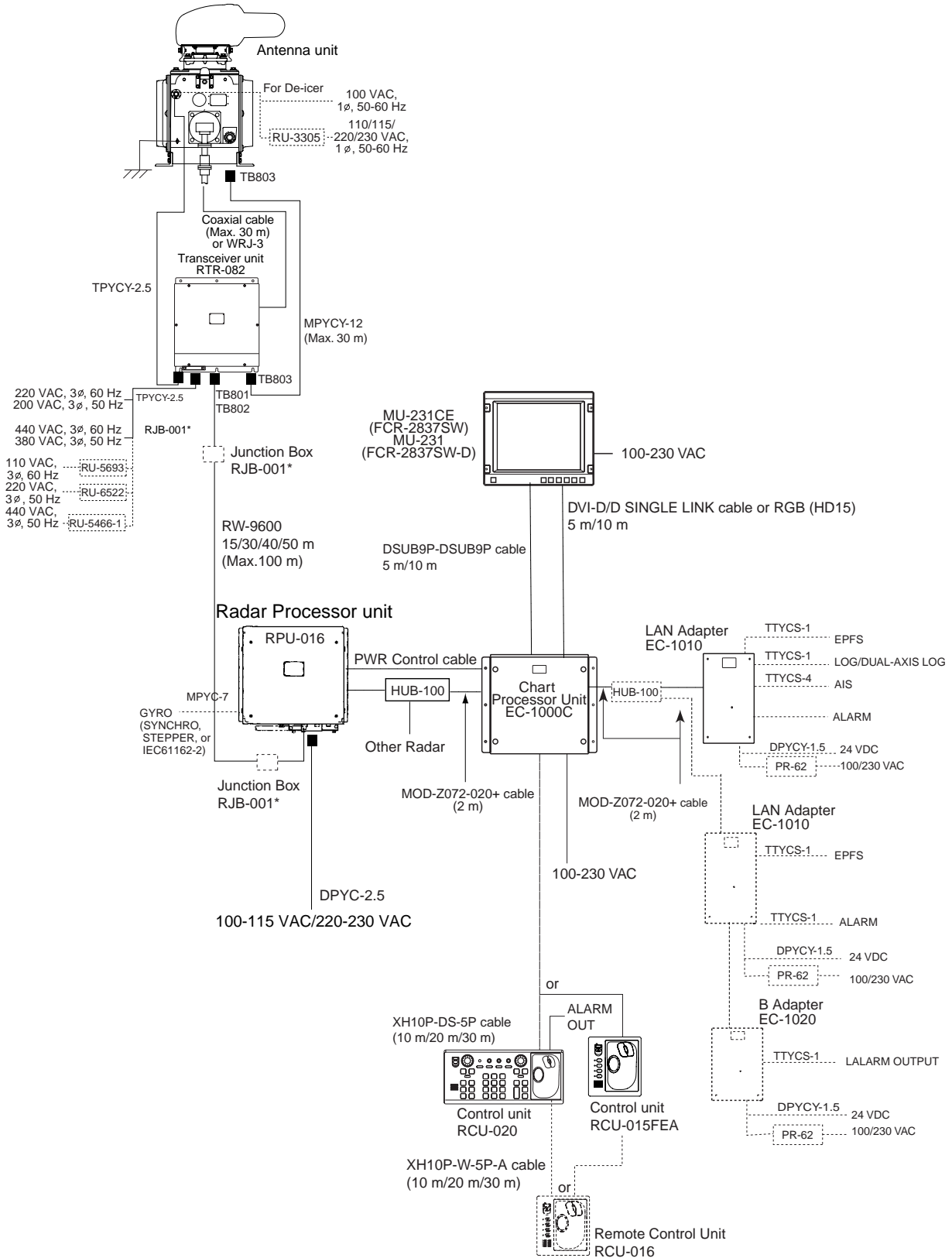

\*: If the cable run between the antenna unit and radar processor unit is more than 100m, use Junction box RJB-001. However, the maximum length is 300m.

■ : Cable requires fabrication

### *Standard Interconnection (FCR-2837SW/2837SW-D)*

## 2.2 Antenna Unit

### 2.2.1 FCR-2827W/2827W-D (RSB-103)

The antenna unit requires the MPYCY-19 (Japan Industrial Standard cable) or equivalent to connect to the transceiver unit RTR-081.

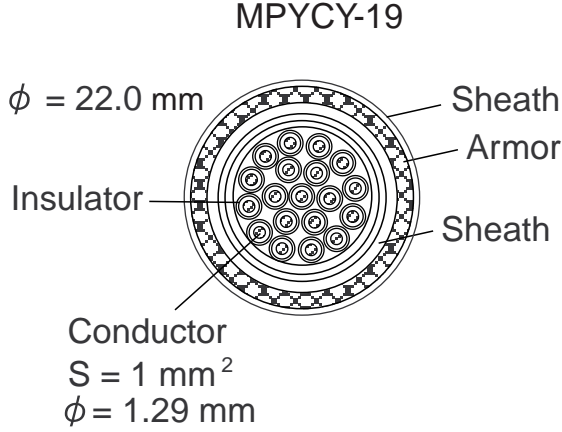

*MPYCY-19 cable, sectional view*

1. Remove the antenna covers.
2. Unscrew the clamping gland and take out the washers, rubber packing and cover.
3. Fabricate the cable as below.

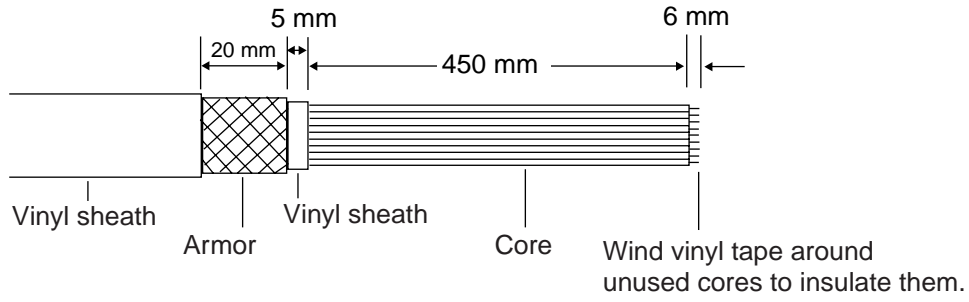

For not used cores, wind the vinyl tape around them to prevent the short circuit.

4. Slide the clamping gland, washer, gasket and washer in that order on to the cable as shown below.
5. Fold back the armor by 5 mm, then put it between washers.

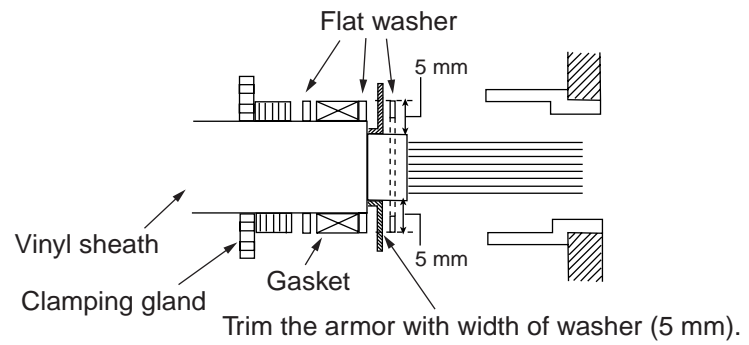

6. Tighten the cable gland, and then cover the junction with putty for waterproofing.

## 2. WIRING

7. Connect the cores to the connector plug TB803 by referring to the interconnection diagram. Leave "slack" in the coaxial wire to prevent breakage.  
Use the terminal opener to insert each core.

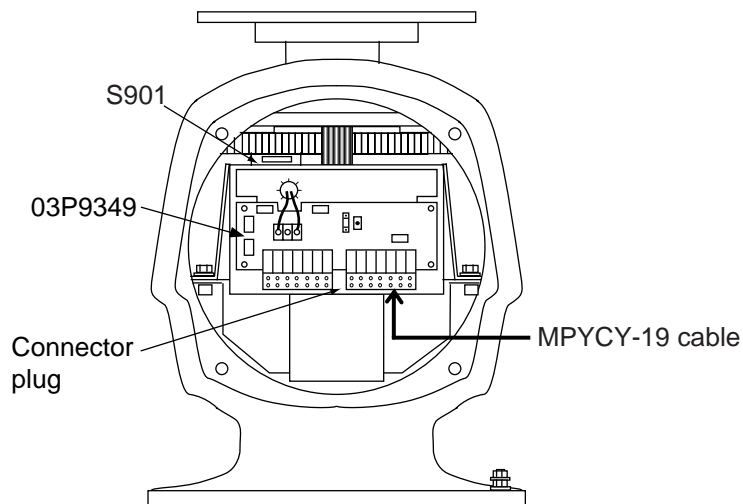
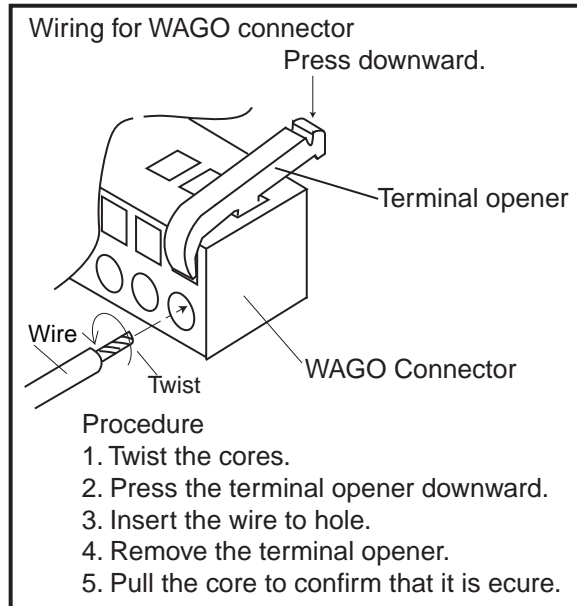

*Antenna unit, internal view*

8. Confirm that all screws are tightened and all wirings are properly made. Confirm that waterproofing gasket, bolts and tapping holes of antenna unit are coated with silicone grease.

### **Waveguide connection at antenna unit**

The signal cable entrance (cable gland) is located directly below the waveguide outlet. If the waveguide is installed downward from the waveguide outlet position using an E-bend waveguide, you may not be able to insert the signal cable into the cable gland. To avoid this inconvenience, shift the waveguide run left or right using an H-bend waveguide as shown below.

The E-bend and H-bend waveguides are contained in the waveguide materials set 22X-CW or 52X-CW.

E-bend type RWA-1030 B-107, Code No. 310-100-140

H-bend type RWA-1050 C-109, Code No. 310-100-180

### **When the de-icer is installed**

- Before beginning any work on the antenna unit, turn off the breaker for the de-icer line at the main switchboard to remove the power (100 VAC, 1 $\Phi$ ) to the de-icer. (Turning off the power to the display unit has no effect.)
- The neck of the antenna unit becomes **VERY HOT** when the de-icer is working. (The de-icer turns on when ambient temperature goes down to 5 C and goes up to 2-5 12 C.)

### 2.2.2 FCR-2837SW/2837SW-D (RSB-104/105)

The signal cable MPYCY-12 (Japan Industrial Standard cable or equivalent), power cable TPYCY-2.5 (Japan Industrial Standard cable or equivalent) and microwave coaxial cable (LHPX-20-ASSY) are used between the antenna unit and transceiver unit.

#### MPYCY-12 cable

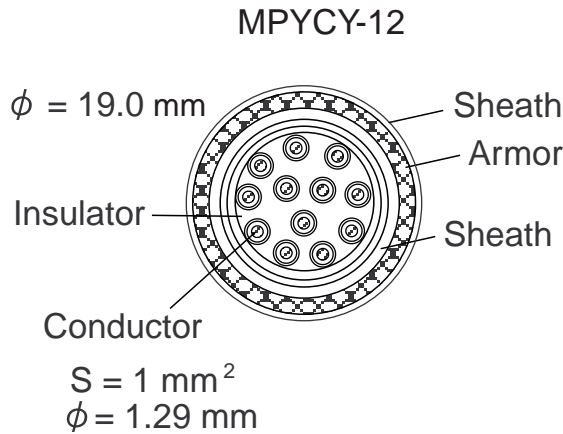

*MPYCY-12 cable, sectional view*

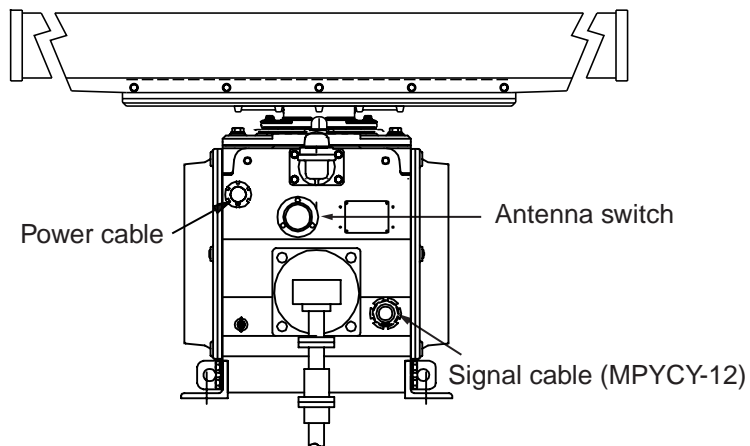

*Antenna unit, front view*

1. Remove the right-hand side cover (viewing from the bow) from the antenna unit by unscrewing ten bolts (13 mm).
2. Unfasten the clamping gland (for signal cable), and remove the gasket, flat washers and cover.
3. Fabricate MPYCY-12 cable as below.

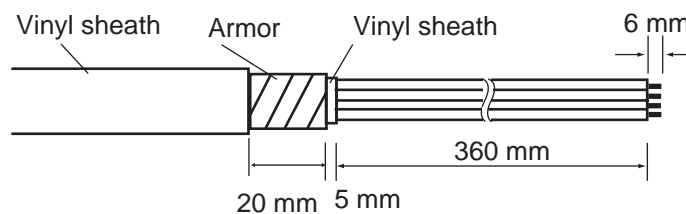

4. Slide the clamping gland, flat washer, gasket and flat washer in that order on to the cable. (See the figure on the next page.)
5. Fold back the armor by 5 mm, then put it between washers.

5. Fold back the armor by 5 mm, then put it between washers.

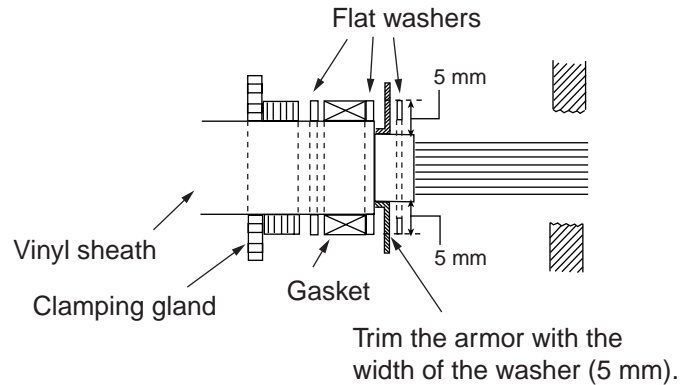

*Passing clamping gland, washers and gasket on the signal cable*

6. Catch the armor between two flat washers for grounding.
7. Apply sealant 1211 (supplied as installation material) to threads of the clamping gland, and then fasten it tightly.
8. Determine the length of the cores considering their location on the terminal board TB803, and then connect cores to TB803 by using the terminal opener.

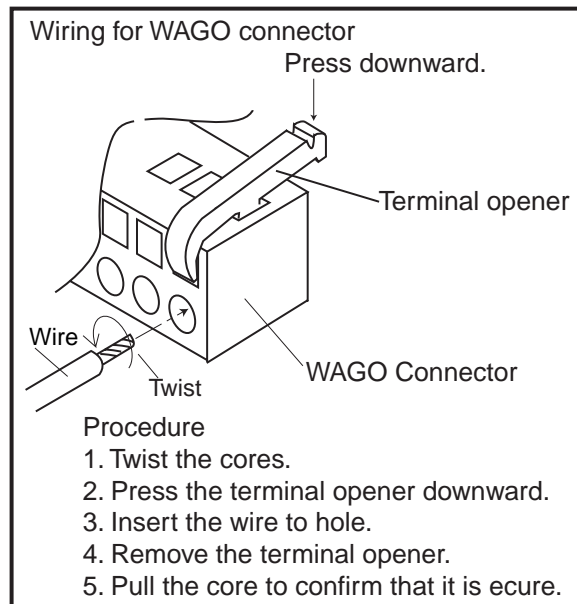

## 2. WIRING

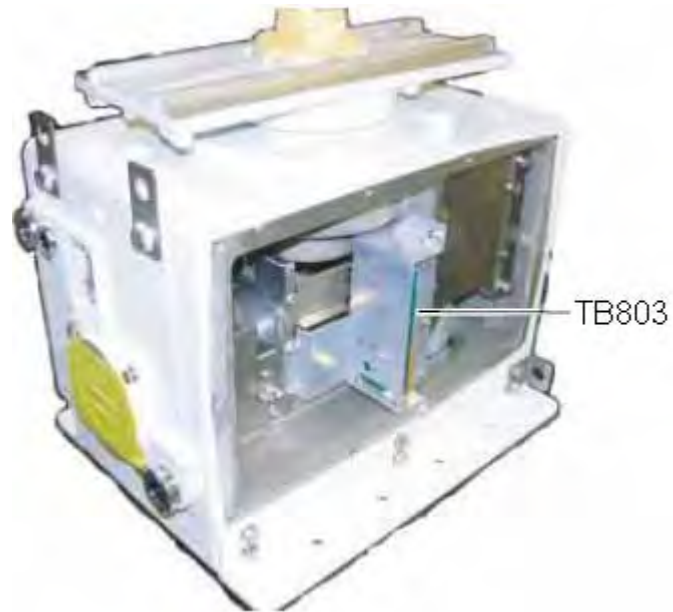

*Antenna unit, cover removed*

9. Reattach the antenna cover, and then cover the gland junction with putty for waterproofing.

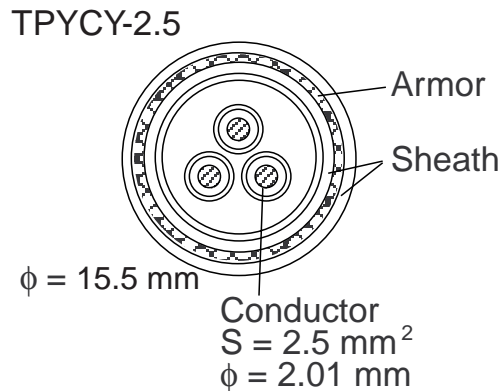

**TPYCY-2.5 power cable***TPYCY-2.5 cable, sectional view*

1. Remove the left-hand side cover (viewing from the bow) from the antenna unit by unscrewing ten bolts (13 mm).
2. Fabricate the cable as below.

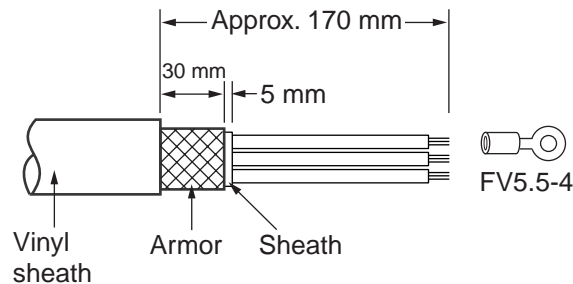
*Fabricating of TPYCY-2.5*

3. Unfasten the clamping gland (for power cable) to remove the gasket, flat washers and cover.
4. Slide the clamping gland, flat washer, gasket and flat washer in that order on to the cable. (See the figure in below.)
5. Fold back the armor by 5 mm, and then put it between washers.

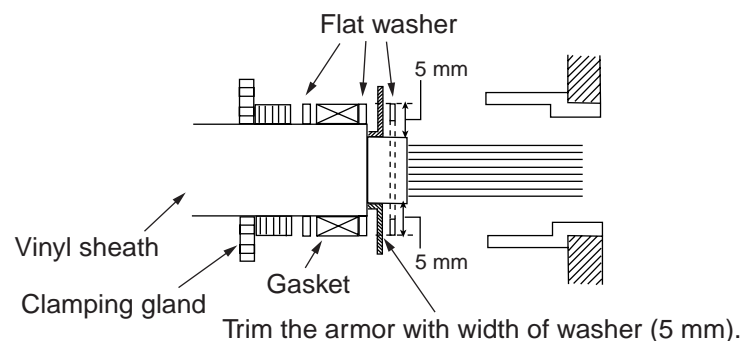
*Clamping gland (for power cable)*

6. Run the power cable behind of the terminal board, and then fix it with the clamp.

## 2. WIRING



*Antenna unit, cover removed (left-hand side)*

7. Determine the length of the cores considering their location on the terminal board TB902, and then connect cores to TB902 by using the terminal opener.
8. Reattach the antenna cover.
9. Cover the gland junction with putty for waterproofing.

**When the De-icer is installed:**

1. Before beginning any work on the antenna unit, turn off the breaker for the de-icer line at the main switchboard to remove the power (100 VAC, 1 $\emptyset$ ) to the de-icer. (Turning off the power to the display unit has no effect.)
2. The neck of the antenna unit becomes **VERY HOT** when the de-icer is working. (The de-icer turns on when ambient temperature goes down to 5°C and goes up to 12°C.)

**Coaxial cable**

When connecting the coaxial cable to the antenna unit, follow the steps below.

1. Unfasten eight bolts (M6x20) to remove the flange cover from the antenna unit.
2. Apply grease to the O-ring located in the flange.
3. Coat between mating surfaces of the coupler at the end of the coaxial cable and waveguide flange as below with waterproofing compound (supplied with installation materials). Do not coat the O-ring.

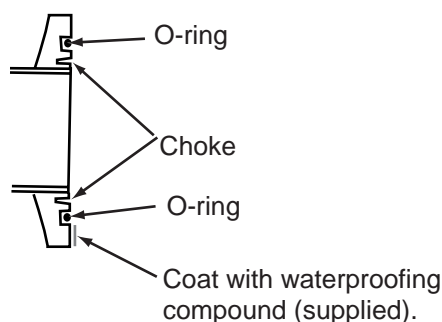

4. Screw eight bolt unfastened at step 1 to fix the coupler to the flange.

**Lying of microwave coaxial cable**

Secure the cable with fixing bands (supplied) or clamping metal (option, type: 03-011-3228, code no.: 100-049-620) to the mast and to the wheelhouse structure.

For the optional deck-thru cable gland, see the outline drawing at the back of this manual.

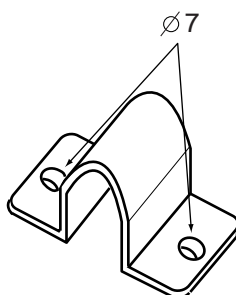

*Clamping metal (option)*

## 2.3 Transceiver Unit

### For FCR-2827W/2827W-D

#### Fabricating of RW-9600

1. Fabricate the RW-9600 cable as shown right.
2. Trim each wire (except coaxial cable) considering its location on the terminal board.
3. Fold back the shield and cut it leaving 30 mm.
4. Remove insulation of each wire by about 6 mm.
5. Using the terminal opener, insert each core (except coaxial cable) to appropriate connector plug.
6. Insert the coaxial cable to the TB802 on TB Board and fix the shield with cable clamp.

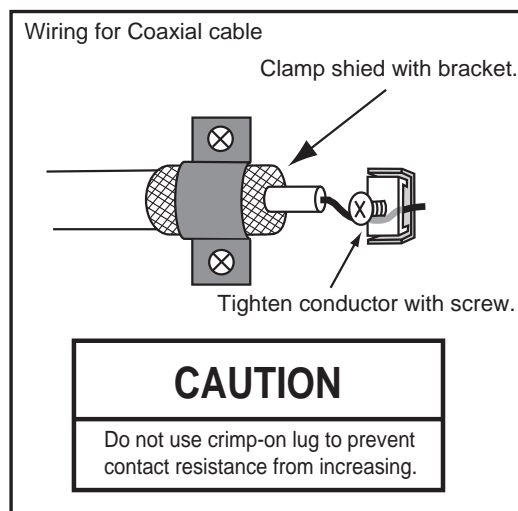
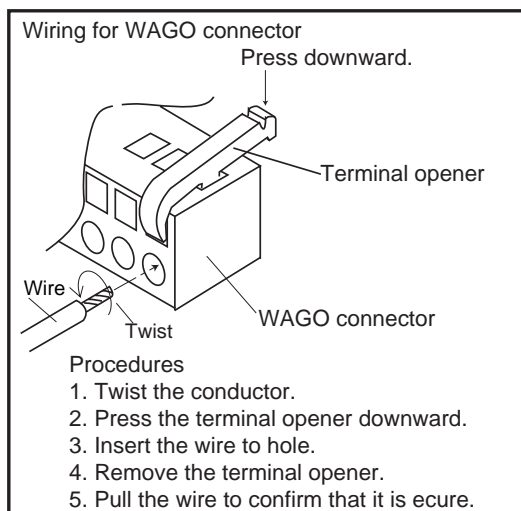
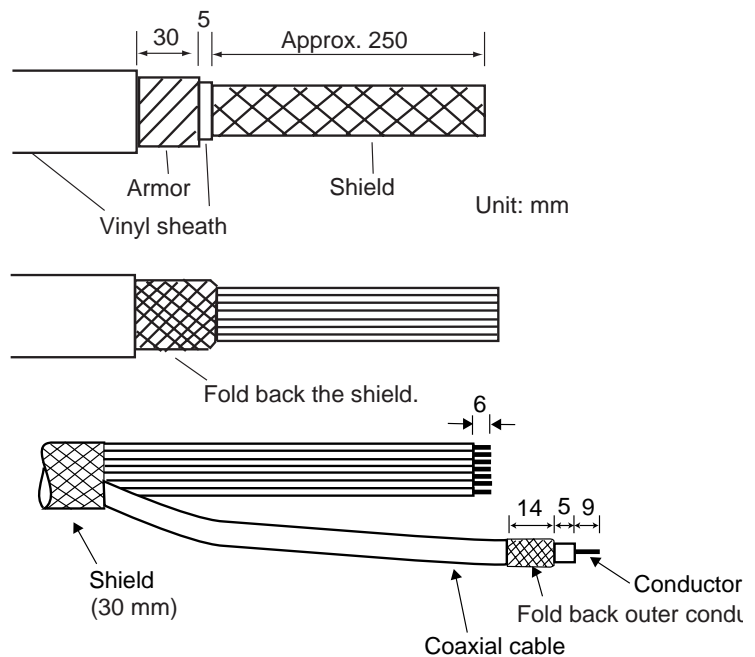

**Fabricating of MPYCY-19**

1. Fabricate the cable as below.

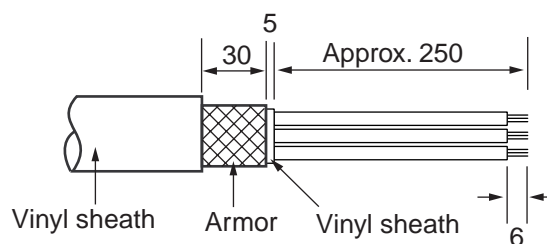

Unit: mm

2. For unused cores, wind the vinyl tape around them to prevent the short circuit.

**Wiring**

1. Remove the cover from the RTR-081.
2. Pass the cables through the cable entrance of the RTR-081, and then fix the armors with the cable clamp.

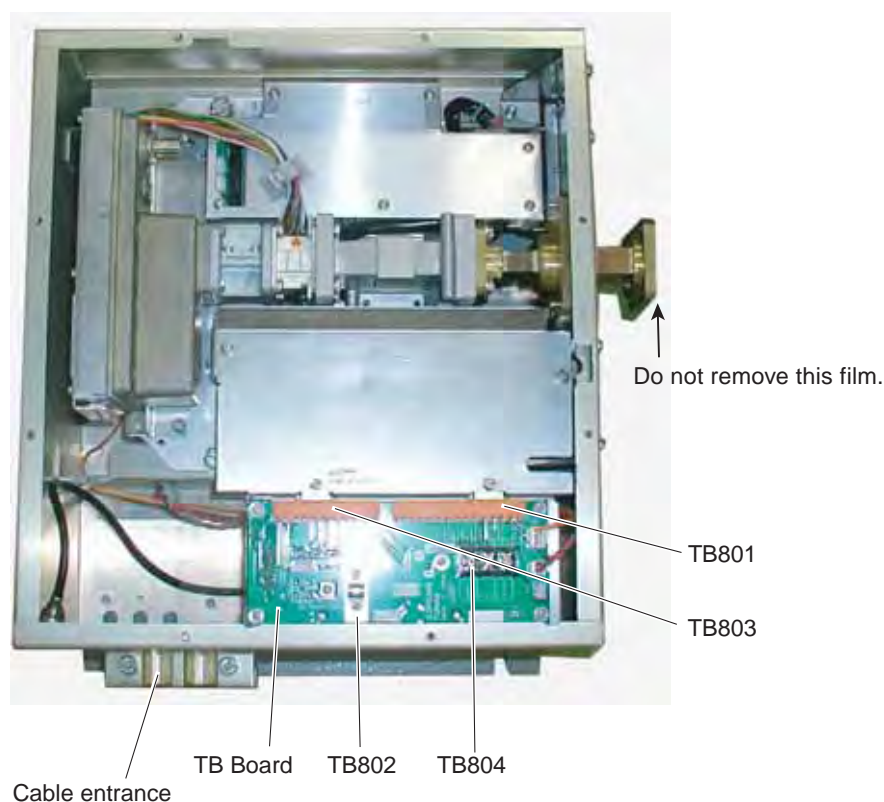
*Transceiver unit RTR-081, internal view*

3. Connect each core to TB801, TB802, TB803 and TB804 referring to the interconnection diagram.
4. Connect the grounding wire (shipyard supply) between the ground terminal (behind the cable clamp) and the grounding point.

## Installing the Rectangular Waveguide (WRJ-9)

The RF interconnection between the antenna unit and the transceiver can be made with a rectangular waveguide (WRJ-9) or flexible (FR-9). If the rectangular waveguide is used, observe the following installation guidelines.

- Correctly installed waveguide runs ensure the most efficient transmission of electrical energy at high frequencies. Electrical losses, however, occur in the waveguide runs. To minimize them the following factors are of great importance: minimum length, airtightness and electrical continuity.
- Another consideration required is that of frequency disturbance. The transmitting valve, a magnetron, is the primary oscillator in the radar. This is different from the oscillation system at lower frequencies in which conventional radio valves are used. In the latter case, the primary oscillator is always protected from the effects of load impedance by a buffer stage so that frequency and waveform are left unobstructed. With a waveguide and magnetron, however, mismatch of impedance causes "frequency pulling." For this reason, the number of possible mismatches in a waveguide run, i.e., joins and bends, must be kept minimum.
- Each pair of flanges should be coupled with one O-ring, four bolts and spring washers and the choke flange must be in the upper position. The bolts and O-ring must be greased before insertion to facilitate removal if required at a later date.
- The transceiver unit output flange is a plain type and the antenna unit output flange is a choke type, and it is important to maintain this relationship throughout the waveguide run.

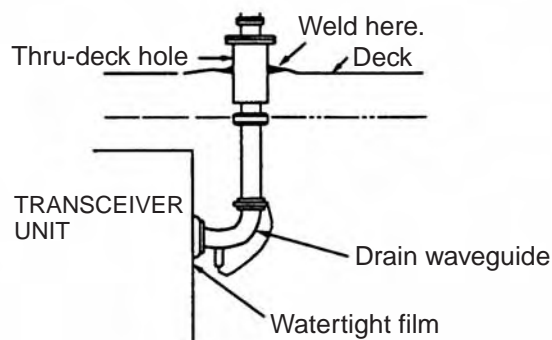

### *Flange connection*

- After installation of the waveguide is completed, the coupling portions must be sealed by using the adhesive supplied.
- In a very short time the surface of the waveguide becomes green with verdigris. Therefore, paint both the surface of the waveguide and flanges to avoid corrosion and water penetration. Paint must not be allowed to reach the inner surface of the waveguide or the mating surface of any flange.

## For FCR-2837SW/2837SW-D

### Fabricating of RW-9600

Refer to page 2-12.

### Fabricating of MPYCY-12

1. Fabricate the cable as below.

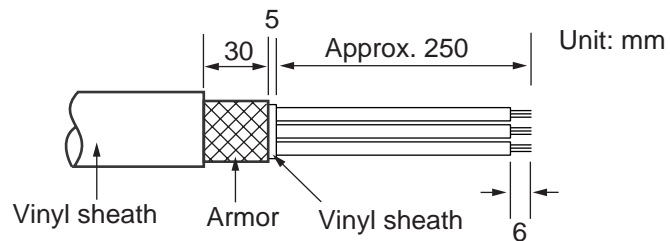

2. For unused wires, wind vinyl tape around the core to prevent short circuit.

### Fabricating of TPYCY-2.5

1. Fabricate the cable as below.

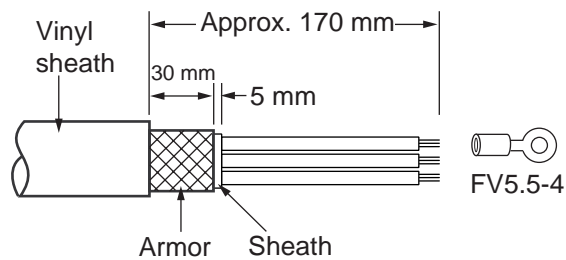

2. Fix the crimp-on lug (FV5.5-4, yellow) to each conductor.

## 2. WIRING

### Wiring

1. Remove the cover from the RTR-082.
2. Pass the cables through the cable entrance, and then fix the armor with the cable clamp.
3. Connect each wire to TB801, TB802, TB803, TB911 and TB912 referring to the interconnection diagram.

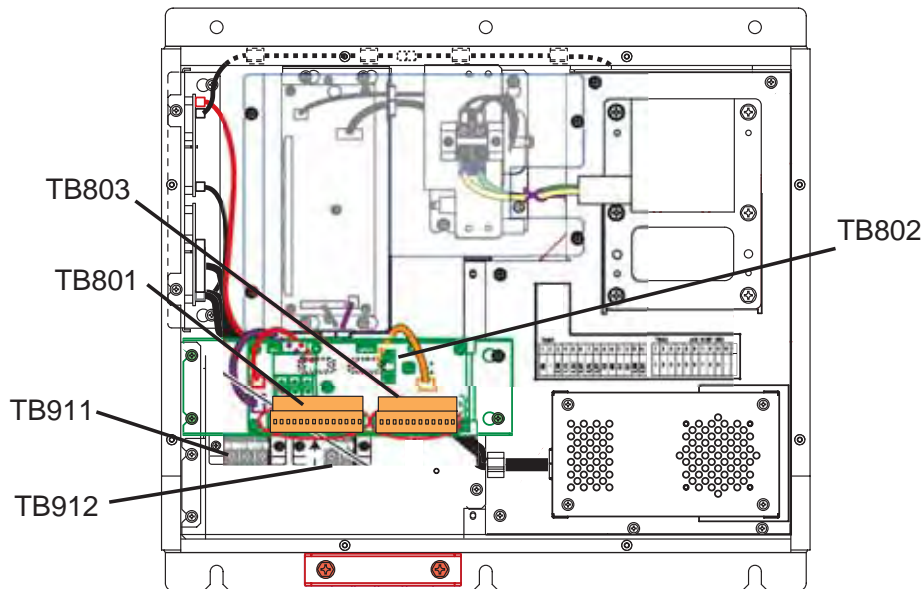

*Transceiver unit RTR-082, internal view*

4. Connect the grounding wire (shipyard supply) between the grounding terminal (behind the cable clamp) and grounding point.

### Connecting the coaxial cable

Connect the coaxial cable to the transceiver unit as below.

1. Loosen eight bolts (M6x20) to remove the dust cover from the output WG adapter.
2. Fasten eight bolts (removed at step 1) to attach the flange to the transceiver unit.
3. Attach the coaxial cable to the converter of the flange.

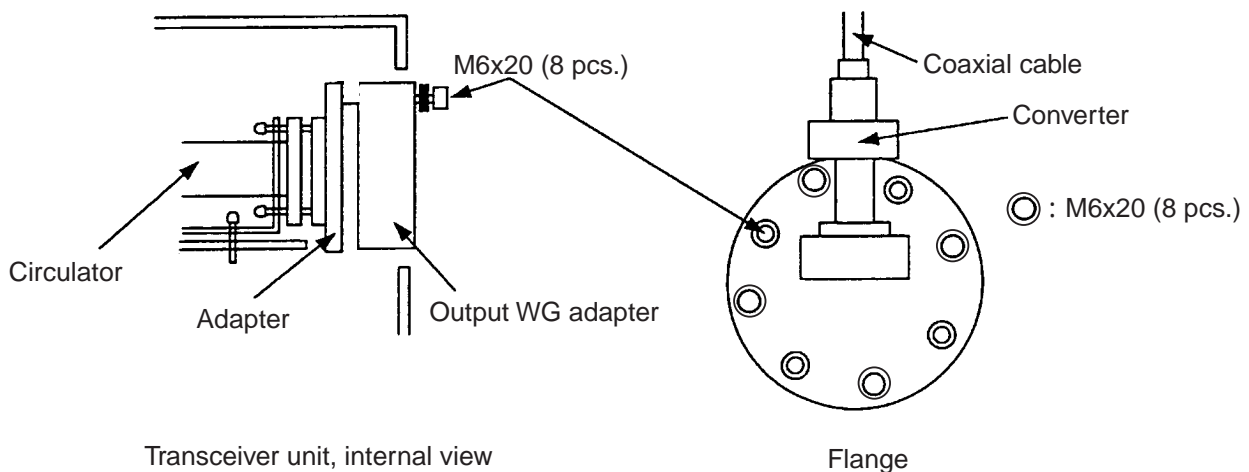

Transceiver unit, internal view

Flange



## 2.4 Monitor Unit

Three cables are terminated at the monitor unit: two signal cables from the chart processor unit and one power cable from the ship's mains. For MU-231, see its Operator's Manual.

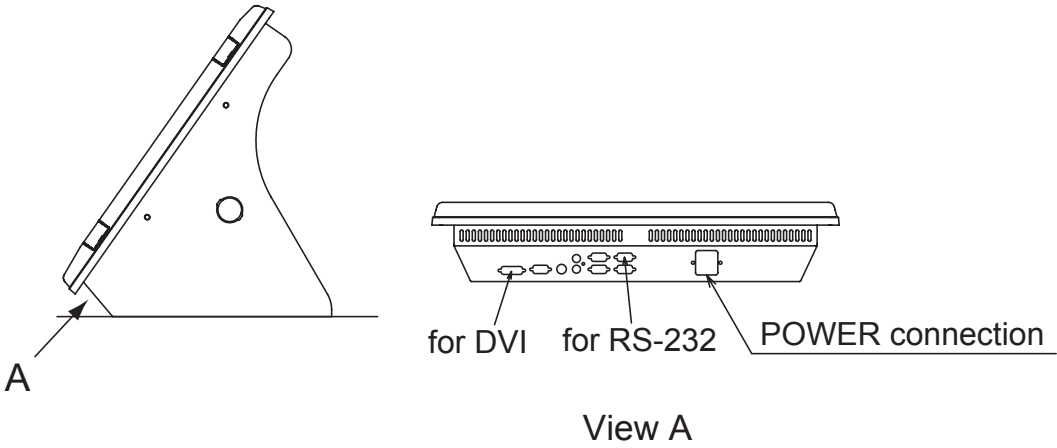

*Monitor unit*

## 2.5 Radar Processor Unit

Three cables are terminated at the radar processor unit: the antenna unit cable, switching hub cable, and the power cable. Cables other than the power cable come with a connector preattached to them for connection to the processor unit. Fabricate the power cable as below. For the power cable, use DPYC-2.5 (Japan Industry Standard) cable or the equivalent.

### Note: For AC unit

Pass the AC line through a double-contact breaker (shipyard supply).

### Fabricating the power cable

1. Cut armor of the cable by 40 mm.
2. Cut vinyl sheath by 35 mm.
3. Remove insulation of wires by about 10 mm. Fix crimp-on lugs to the cores.
4. Scrape off paint of the armor by 40 mm.
5. Cover the end of armor with vinyl tape.

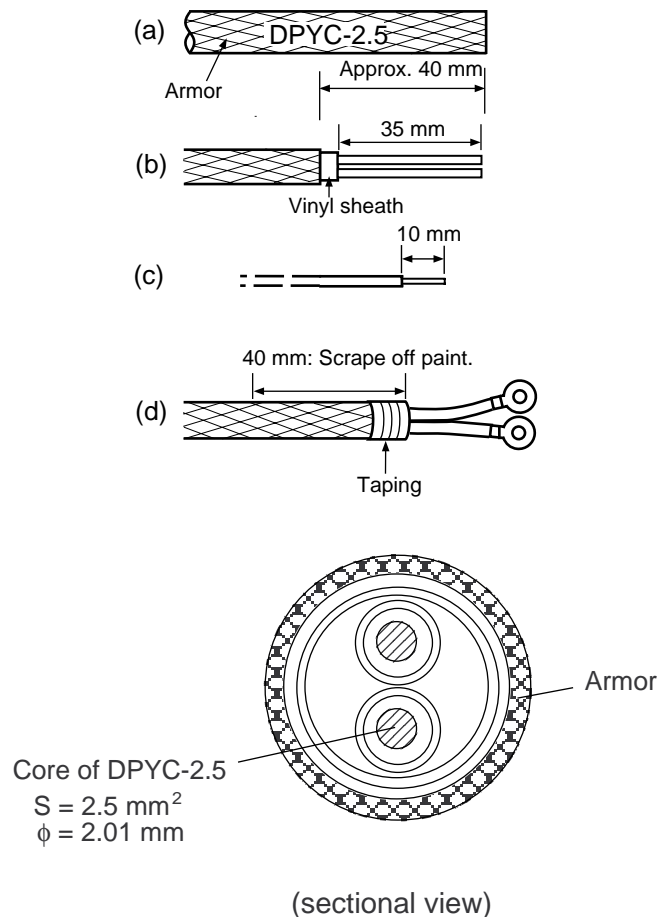

*Fabricating power cable DPYC-2.5*

### Connection of cables

The power cable is connected to the terminal board on the rear panel. Other cables are connected to the printed circuit board 03P9342.

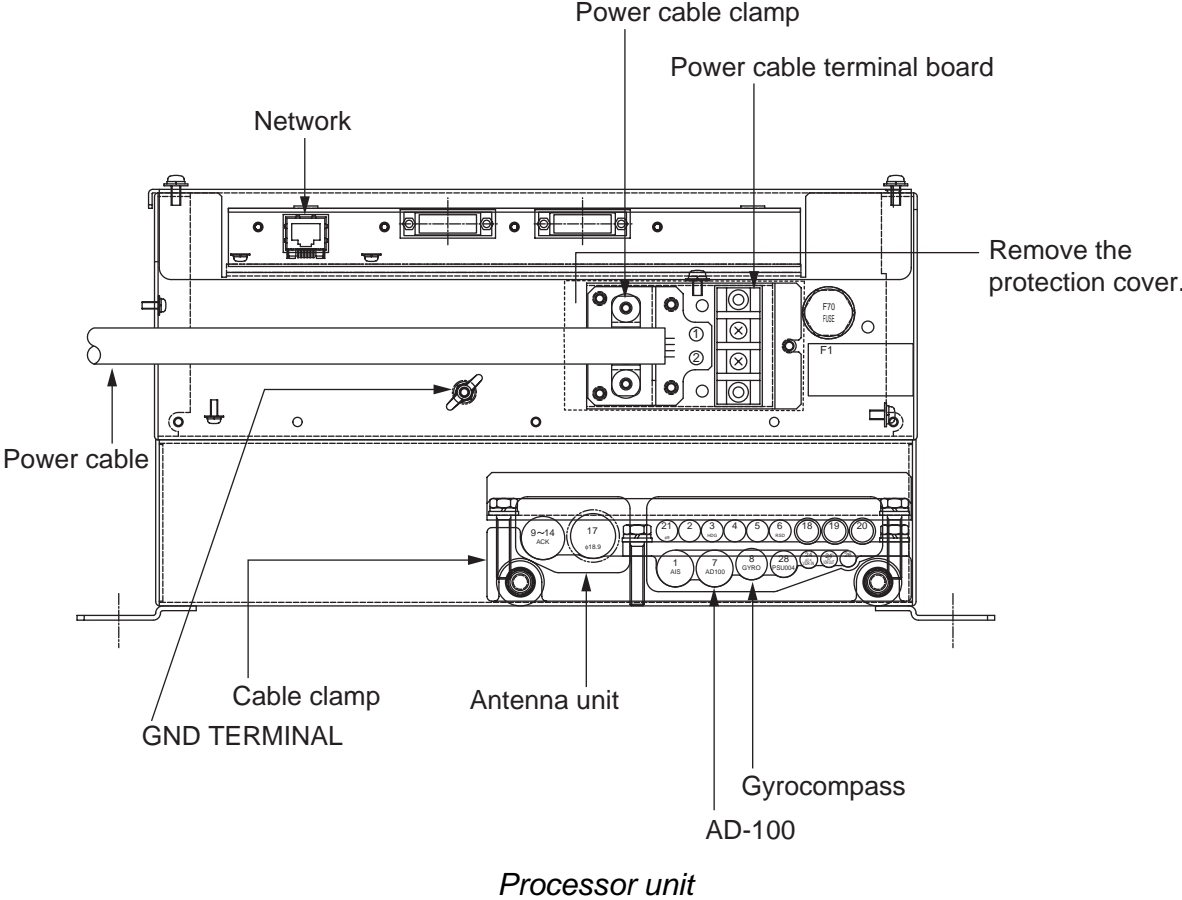

### Location of connectors

Open the processor unit as follows and the 03P9342 board appears.

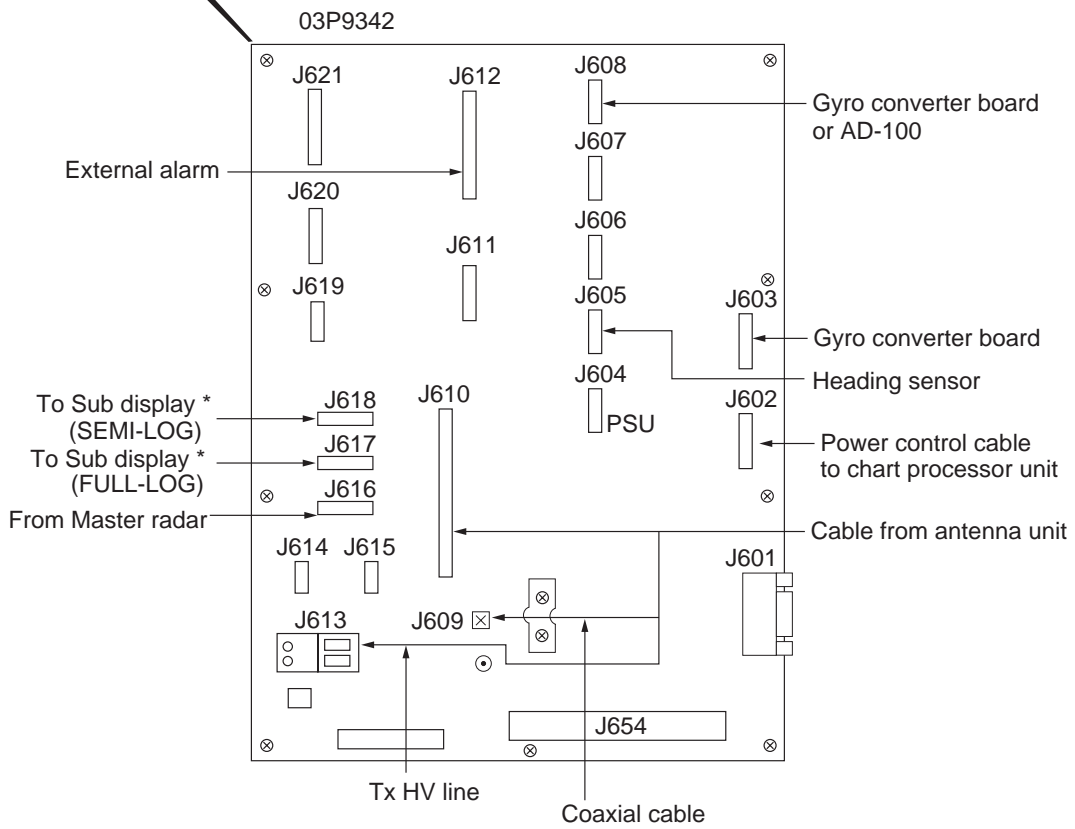
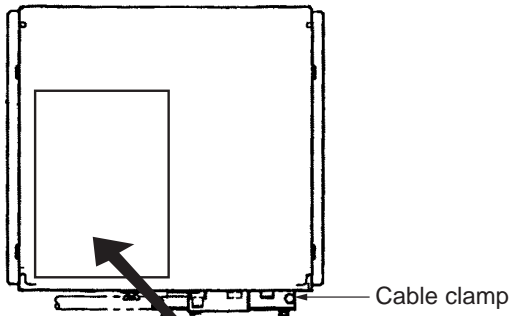
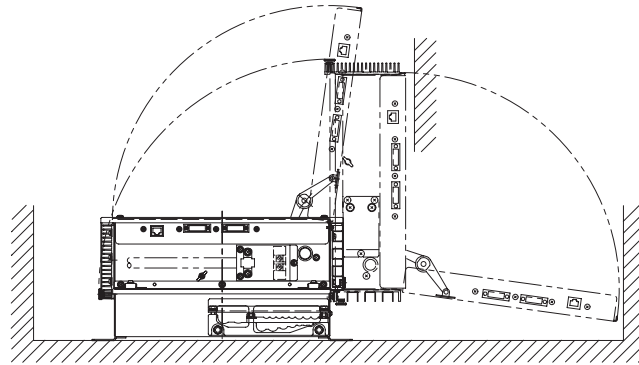

03P9342

\*: See page 2-27 for details.

**Cable fabrication for the cables connected to the 03P9342 board**

- Signal cable RW-9600 (Between transceiver unit and radar processor unit)

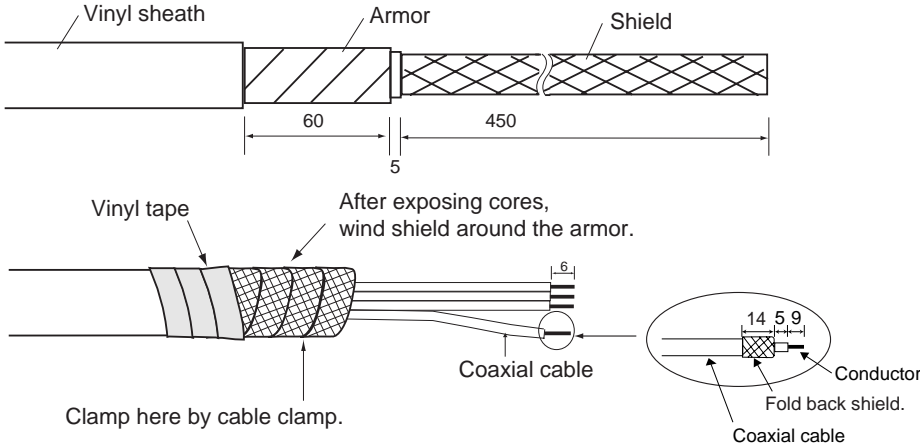

- Other cables for optional units  
Use TTYCS-1 or TTYCS-1Q (Japan Industry Standard cable) or equivalent.

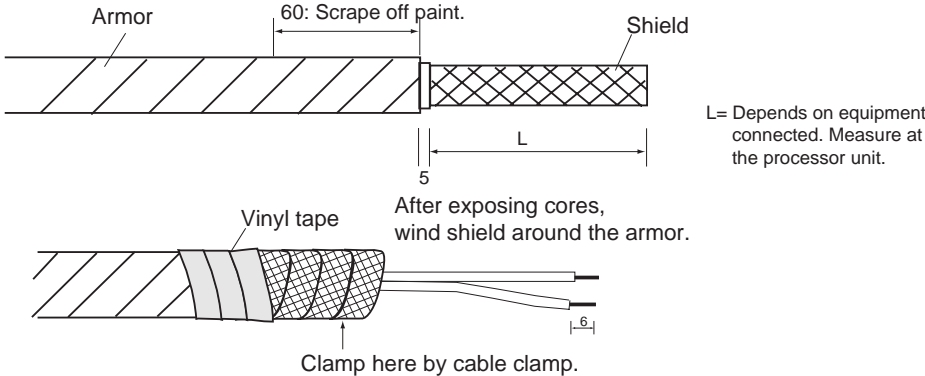
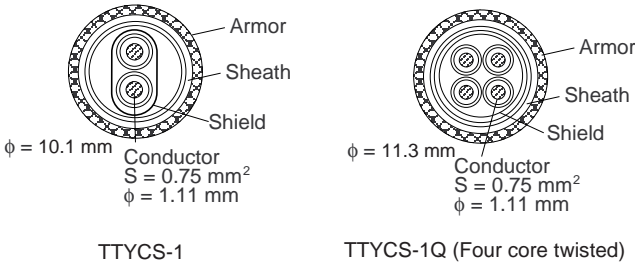

Wiring for WAGO connector

Press downward.

Terminal opener

Wire

Twist

WAGO connector

Procedures

1. Twist the conductor.
2. Press the terminal opener downward.
3. Insert the wire to hole.
4. Remove the terminal opener.
5. Pull the wire to confirm that it is secure.

Wiring for Coaxial cable

Clamp shield with bracket.

Tighten conductor with screw.

**CAUTION**

Do not use crimp-on lug to prevent contact resistance from increasing.

## Connection of Sub-display

A conventional remote display and/or FCR-2107 series radar can be connected to J617 and J618 in the processor unit as a sub-display. However, the controls for GAIN and STC are different depending on J617 and J618. Refer to the table below.

Port		Conventional remote display	FCR-2107 series radar
J617 (FULL-LOG)	Overall gain	Even if input video level is adjusted to 4 Vp-p, the gain is 8 db lower than that on the master radar.	The gain is 8 dB lower than that on the master radar.
	GAIN control	The GAIN control functions.	The GAIN control does not function.
	STC control	The STC control functions.	The STC control does not function.
J618 (SEMI-LOG)	Overall gain	When input video level is adjusted to 4 Vp-p, the gain becomes the same as that on the master radar.	The gain is almost same as that on the master radar.
	GAIN control	The GAIN control functions.	The GAIN control does not function.
	STC control	The STC control functions, however this control is added on the signal adjusted by the master radar. So this port is not recommended to use .	The STC control does not function.

## 2.6 Changing AC Power Specification of Radar Processor Unit

To change AC power voltage between 100 VAC and 220 VAC, add or remove jumper connector P108 on the PWR board 03P9339 and change the fuse on the processor unit according to ship's mains as shown in the table below. The figures below and on the next page show the location of the fuse and the jumper plug on the PWR board. Also, adjustment of the overvoltage detection circuit is required.

**Note:** To change from 200 VAC to 100 VAC, locally prepare the jumper plug, referring to the figure shown on the next page (VH8P connector housing is fitted at J108).

Power supply	Fuse	Jumper plug
100 VAC	10A	Added
220 VAC	5A	Removed

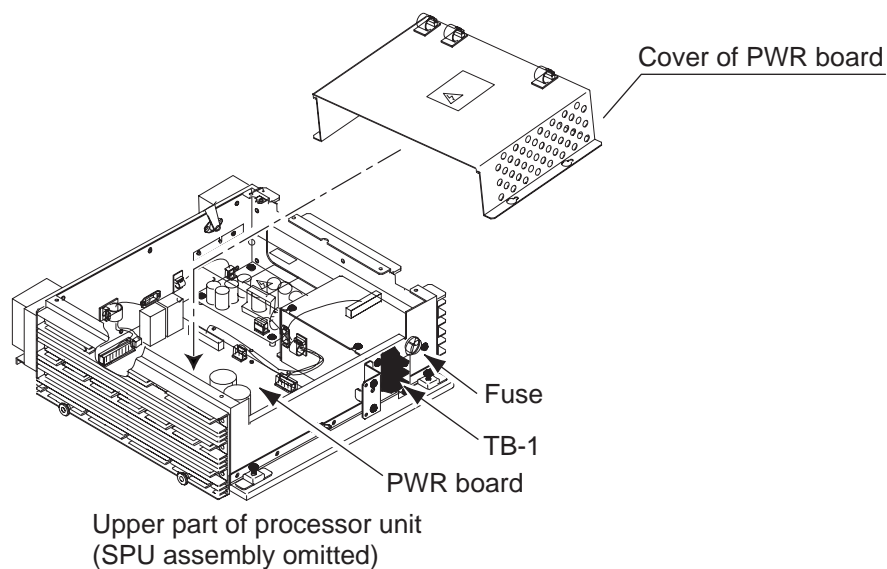

## 2. WIRING

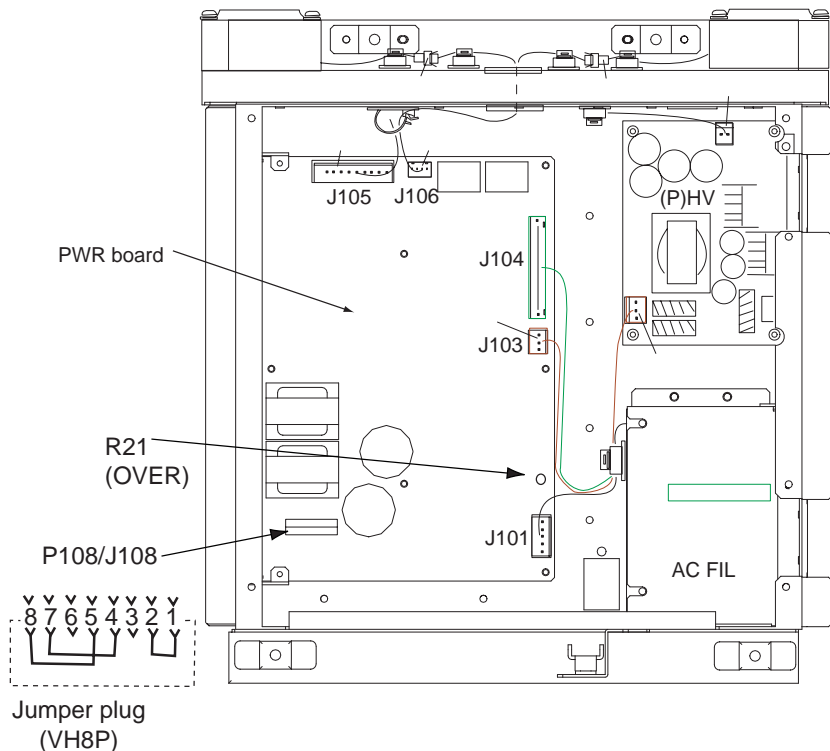

### How to adjust the overvoltage detection circuit:

1. Add or remove the jumper connector P108 and change the fuse.
2. Rotate R21 fully clockwise on the PWR board.
3. Connect a variable transformer between ship's mains and the input power terminal board TB-1 of the processor unit.
4. Set the variable transformer output (i.e., input voltage to the processor unit) as follows.  
For 100 VAC set: 144 VAC  
For 220 VAC set: 288 VAC
5. Turn on the radar and gradually rotate the R21 counterclockwise until the overvoltage detection circuit functions (i.e., power supply cuts off).
6. Lower the output voltage of the variable transformer and confirm that the radar turn on with a voltage lower than 142VAC or 284VAC.
7. Gradually increase the output voltage of the variable transformer and confirm that the overvoltage detection circuit functions at 144V or 288VAC of the variable transformer output.
8. Assemble the processor unit.



## 2.7 Chart Processor Unit

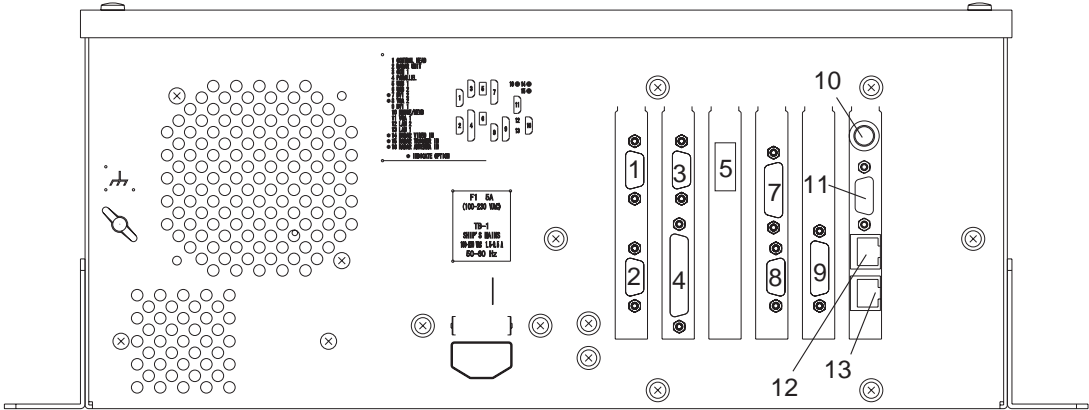

- 1: CONTROL UNIT
- 2: RADAR UNIT
- 3: COM 1
- 4: PARALLEL
- 5: USB 1
- 7: NOT IN USE
- 8: NOT IN USE
- 9: DVI1
- 10: MOUSE/KEYB.
- 11: VGA1
- 12: LAN 2
- 13: LAN 1

Chart processor unit, rear view

## 2.8 LAN Adapter

### Cables fabrication for the cables connected to the LAN adapter

Use the following JIS (Japanese Industrial Standards) cables or equivalent. When using the TTYCS-4 cable, connect the appropriate cable to it to pass the cable entrance of the adapter.

$\phi = 11.7 \text{ mm}$  Armor Sheath Conductor $S = 1.5 \text{ mm}^2$ $\phi = 1.56 \text{ mm}$	$\phi = 16.3 \text{ mm}$  Armor Sheath Shield Conductor $S = 0.75 \text{ mm}^2$ $\phi = 1.11 \text{ mm}$	$\phi = 10.1 \text{ mm}$  Armor Sheath Shield Conductor $S = 0.75 \text{ mm}^2$ $\phi = 1.11 \text{ mm}$
DPYC-1.5	TTYCS-4 (Four twisted pairs)	TTYCS-1 (Twisted pair cable)

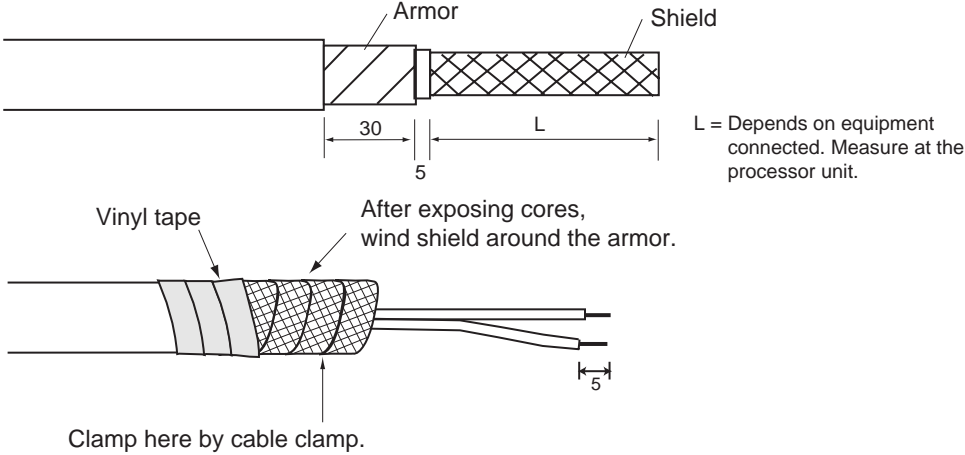

2. WIRING

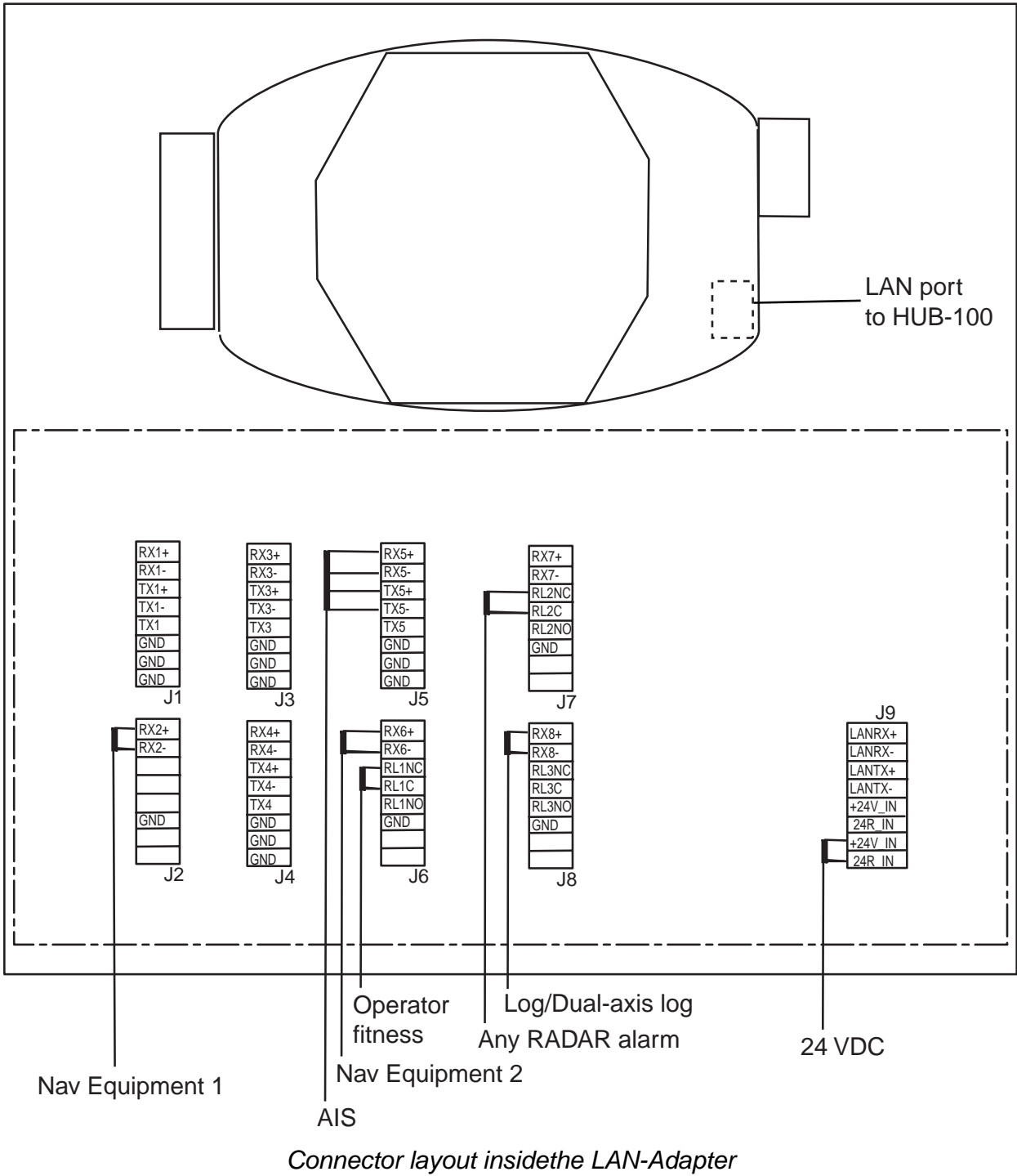

## Serial data channels in general

An example of serial channel (here channel 1)

RX1+ } input terminals for electrical standards IEC 61162-1, and RS-422  
 RX1- } RX+ = A and RX- = B as defined in IEC 61162-1

TX1+ } output terminals for electrical standards IEC 61162-1 and RS-422  
 TX1- } TX+ = A and TX- = B as defined in IEC 61162-1

TX1 output terminals for electrical standard RS-232C

GND ground terminal for RS-232C

## Serial data channel assignment

### First LAN adapter

Channel	Type	bit/s	Standard	Option
1	rx/tx	4800		
2	rx	4800	Pos1	
3	rx/tx	4800		Wind
4	rx/tx	4800	B-Adapter	
5	rx/tx	38400	AIS	
6	rx	4800	Pos2	
7	rx	4800		Echo Sounder
8	rx	4800	Log/Dual-axis log	
Relay1	Relay NC		Operator fitness	
Relay2	Relay NC		Any RADAR alarm	
Relay3	Relay NC			

### Second LAN adapter

Channel	Type	bit/s	Standard	Option
9	rx/tx	4800		Route Backup
10	rx	4800		
11	rx/tx	4800		
12	rx/tx	4800		Speedpilot
13	rx/tx	38400	B-Adapter	
14	rx	4800		
15	rx	4800		
16	rx	4800		
Relay4	Relay NC		Waypoint approach	
Relay5	Relay NC		Outside channel limit	
Relay6	Relay NC		Depth below limit	

## 2.9 VDR

If the distance between VDR and the chart radar is 10 m or less, the VDR can be connected directly to the chart radar as follows.

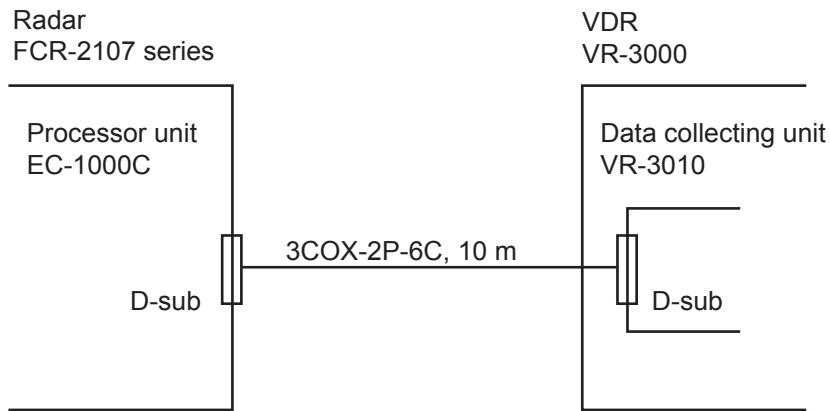

If the distance between them is more than 10 m, use optional conversion cable and coaxial cable(s) as follows.

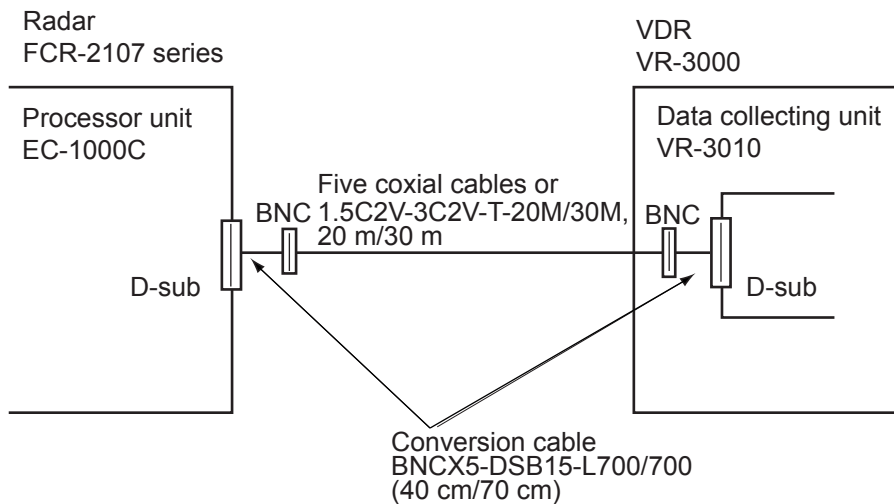

## 2.10 EMI Core for Chart Processor Unit

When connecting the LAN cable MOD-Z072-020+ (supplied) to the chart processor unit EC-1000C, attach the EMI core (type: RFC-10, supplied as installation materials) to that cable as shown below.

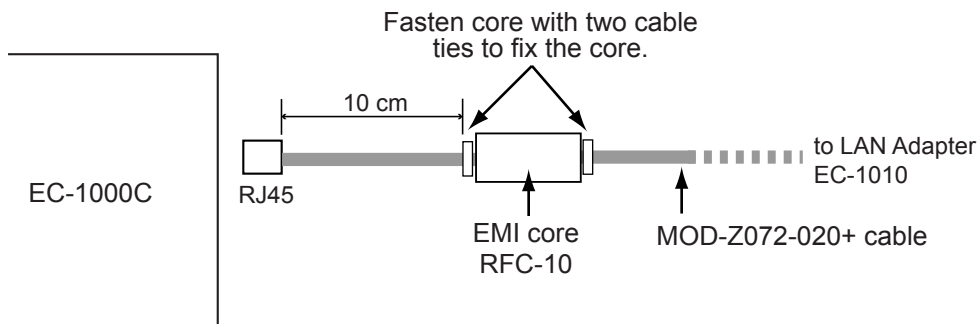

# 3. SETTING AND ADJUSTMENT

---

## 3.1 Radar Processor Unit

The radar processor unit is commonly used with the IMO radar FAR-2xx7 series and the chart radar FCR-2xx7 series. The difference is DIP switch (S1) setting as follows.

- For chart radar S1 - #3: ON (#1 and #2 disable)

S1	Setting
1	OFF
2	OFF
3	ON
4	OFF

- For IMO radar

S1	Monitor SXGA (20.1-inch monitor)	Monitor UXGA (23.1-inch monitor)
1	OFF	ON
2	OFF	OFF
3	OFF	OFF
4	OFF	OFF

## 3.2 Setting IP Address

### Running Windows

The chart processor unit has two local area network interfaces. To set the IP Address, run WindowsXP as follows.

1. Insert the service keyboard to the front panel of the chart processor unit.
2. Turn the chart radar on.
3. While pressing down the **Alt** key, press the **Tab** key on the service keyboard several times to show ECAWATCH window.
4. Release the keys and press the “Shutdown the ECDIS” button on the screen immediately.
5. Press the **Alt** and **F4** keys simultaneously. Now WindowsXP screen appears.

### Local Area Connection for LAN 1 (ARPA Radar Network)

To configure IP Address for Local Area Connection interface, proceed as follows:

1. Open the Control Panel of the Windows.
2. Double click Network Connection icon.
3. Highlight “Local Area Connection1”, and then select **Properties** in File menu.

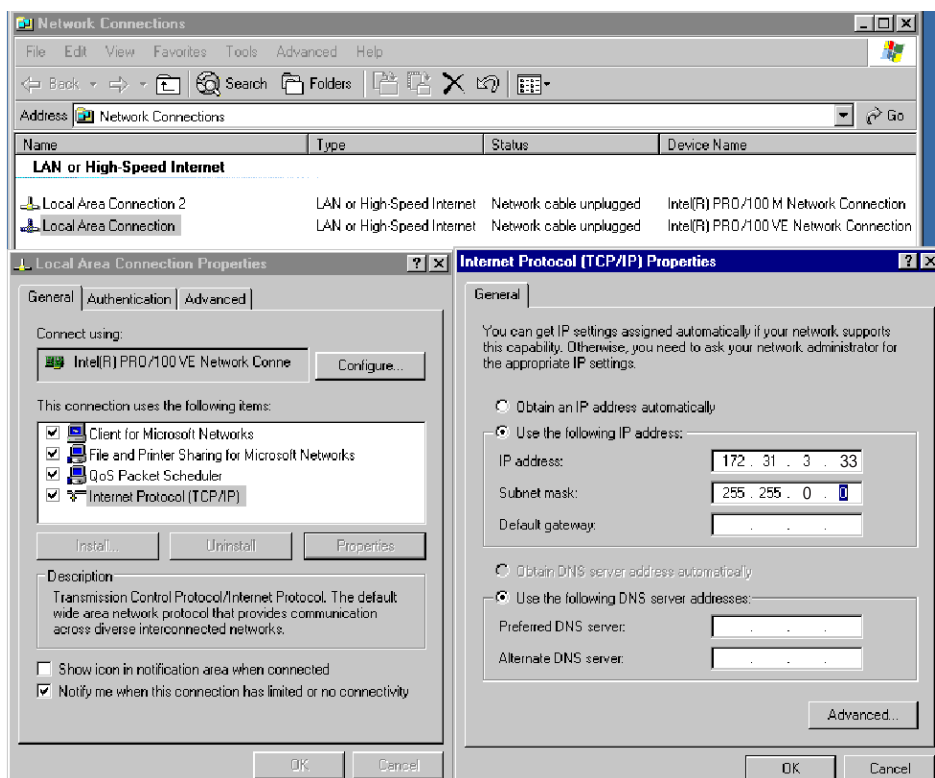

4. In “Local Area Connection1 Properties”, highlight **Internet Protocol (TCP/IP)**, and then press the **Properties** button.
5. Set IP Address as 172.31.3.33 (default) or 172.31.3.34 (for the second Chart radar).
6. Set Subnet mask as 255.255.0.0.
7. Press the OK button to close the window.

### Local Area Connection for LAN2 (LAN IF Network)

LAN2 interface is used to connect LAN Adapter (or HUB-100) to the chat processor unit EC-1000C. To configure IP Address for this, proceed as follows:

1. Open the Control Panel.
2. Double click **Network Connection** icon.
3. Highlight **Local Area Connection 2** and then select **Properties** in File menu.

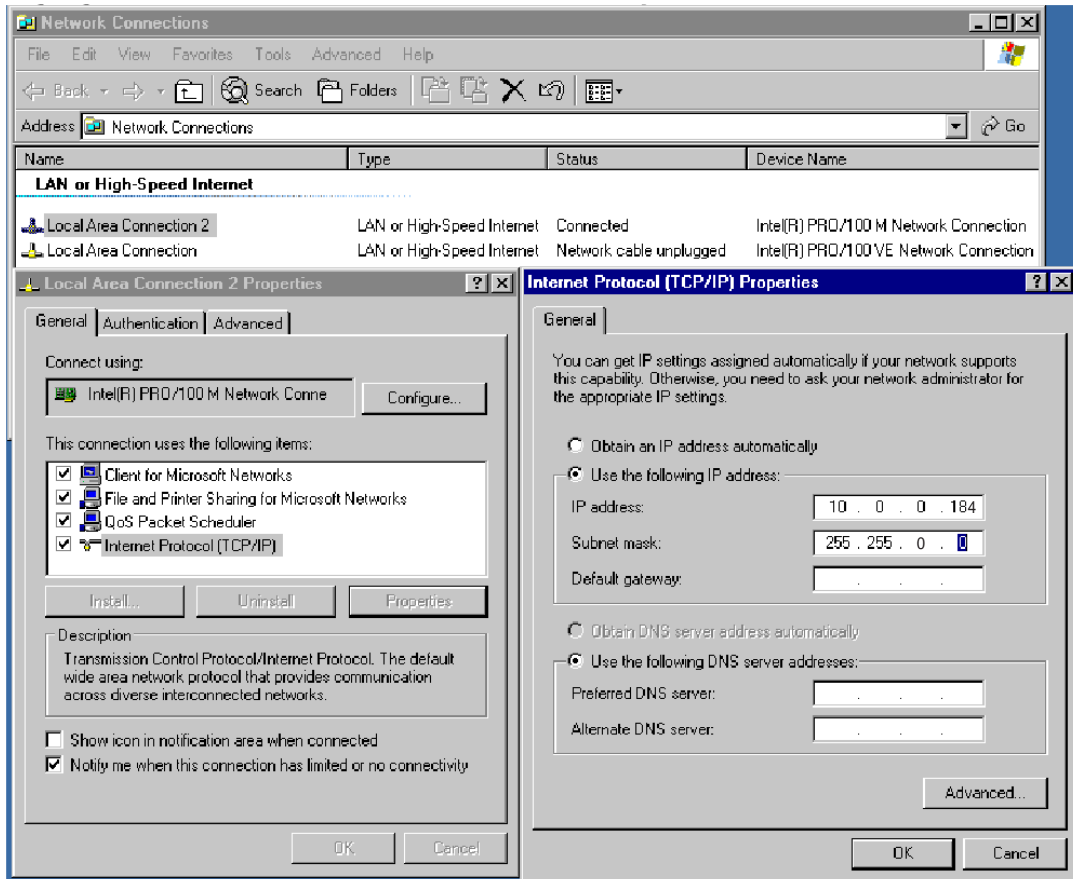

4. In "Local Area Connection 2 Properties", highlight **Internet Protocol (TCP/IP)**, and then press **Properties** button.
5. Set IP Address as 10.0.0.184 (for the first chart radar) or 10.0.0.185 (for the second chart radar).
6. Set Subnet mask as 255.255.0.0.
7. Press the **OK** button to close the window.

### 3. SETTING AND ADJUSTMENT

#### Confirmation of Registry

1. Open the start menu, and then select "Run".
2. Type "regedit", and then click **OK** to open field.

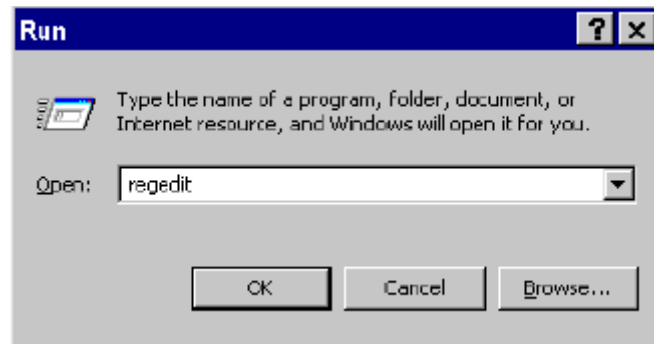

3. Open folder `HKEY_LOCAL_MACHINE\SOFTWARE\FFOY\ECDIS\LANadapter`.

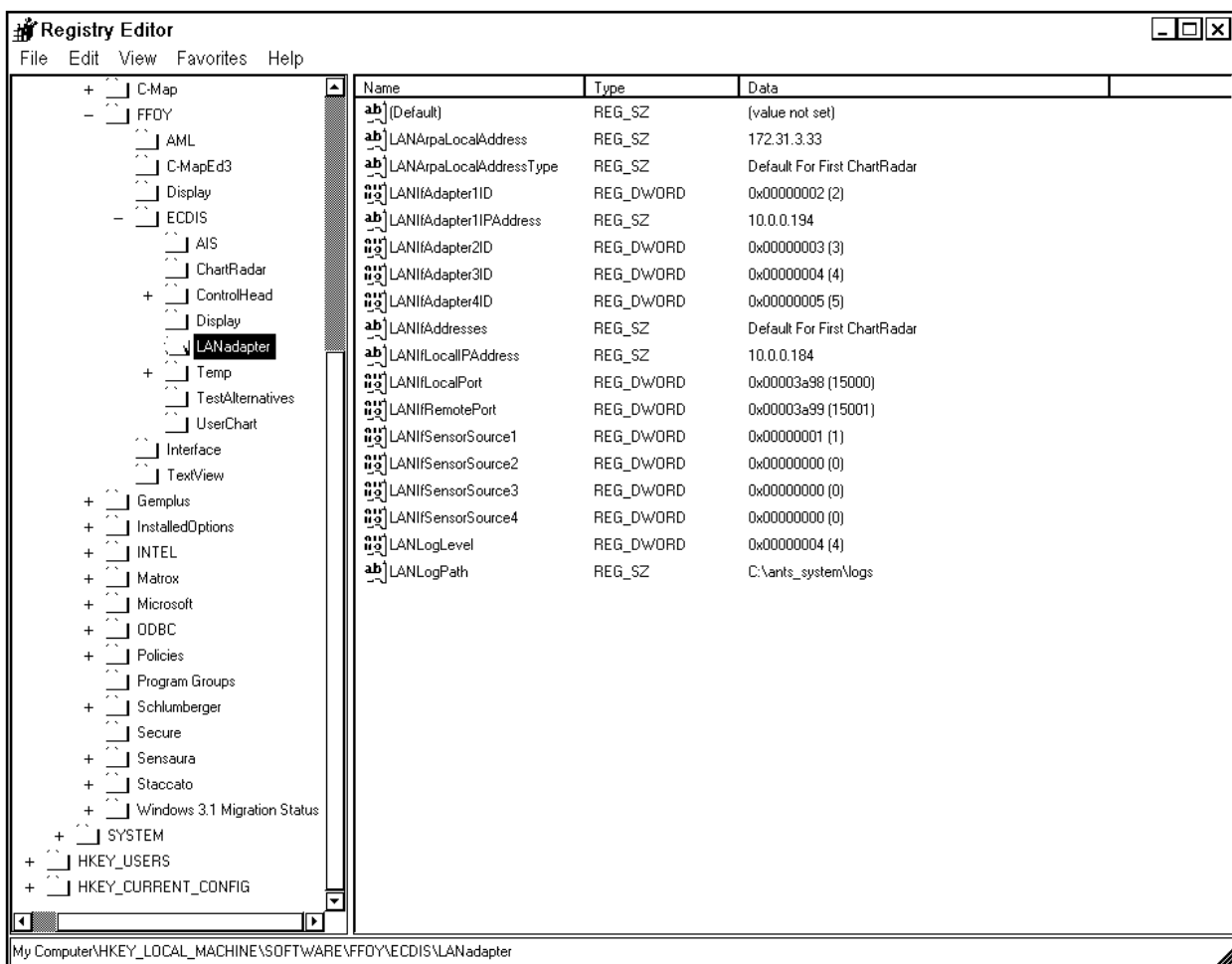



4. Confirm the settings are shown below. If necessary, change it appropriately.

	No.1 Chart radar	No.2 Chart radar
LAN Arpa Local Address	172.31.3.33	172.31.3.34
LAN If Local IP Address	10.0.0.184	10.0.0.185
LAN If Adapter 1ID	0X000000002 (2)	0X000000004 (4)
LAN If Adapter 2ID	0X000000003 (3)	0X000000005 (5)
LAN If Adapter 3ID	0X000000004 (4)	0X000000002 (2)
LAN If Adapter 4ID	0X000000005 (5)	0X000000003 (3)
LAN If Adapter 1 IP Address	10.0.0.194	10.0.0.196
LAN If Adapter 2 IP Address	10.0.0.195	10.0.0.197

5. Close Registry editor.

**To return to radar display**

1. Click the **START** button of the Windows.
2. Click "Turn off Computer".
3. Click **Restart** button. The Windows closes and the radar screen appears.

### 3.3 Setting Radar Number

If multiple radars are connected using the network hub, set as follows.

1. Turn on a chart radar that you want to change its number.
2. Insert the "Authorizing key disk" to the chart processor unit.  
Note that the installation parameters have limited access which is controlled by the Authorization key disk supplied.
3. Press the MENU key on the control unit to show the Main Menu.

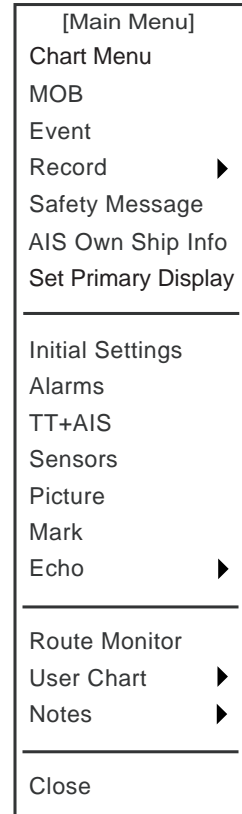

4. Roll the wheel to choose "Initial Settings" to show INITIAL SETTINGS dialog box.

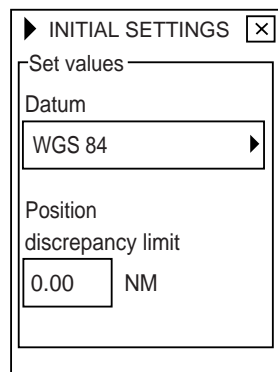

5. Rotate the trackball to place the cursor on the ► mark. The "Initial Settings" menu appears.

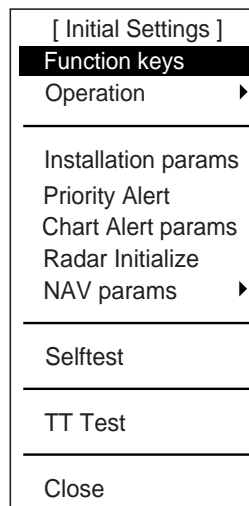

6. Roll the wheel to choose “Radar Initialize” and click the wheel to show Radar Initialize menu and choose “Page 2”.

Installation	
Radar Number	1
Radar	MAIN TOP
Model	25 DOWN
On Time	13497.6
TX Time	11888.9
PM Gain Adj	1

  

Own Ship Info	
Length	240
Width	32
Scanner, bow	120
Scanner, port	16
GPS1, bow	120
GPS1, port	16
GPS2, bow	200
GPS2, port	26
Conning, bow	120
Conning, port	16

7. Place the cursor on the numeric character of Radar Number. Its color changes.  
 8. Roll the wheel to set the radar number, and click the wheel.  
 9. Click x mark to close the Radar Initialize menu.  
 10. Press the MENU key, roll the wheel to choose “Initial Settings”, point the ► mark to display the “Initial Setting” menu (Shown in the figure at step 5).  
 11. Roll the wheel to choose “Installation params” and click the wheel to show the “Installation parameters” dialog box.

### 3. SETTING AND ADJUSTMENT

12. Click the ► mark to show the drop-down list, scroll the list and choose “Radar Echo Overlay / ARPA communication (LAN)”. The following dialog box appears.

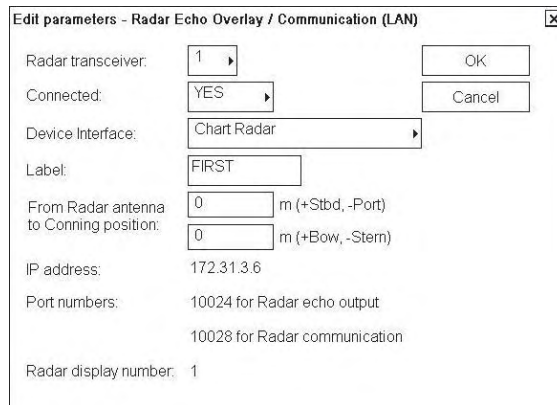

13. In “Radar Transceiver” field, set the same number of the radar number.  
14. In “Device Interface” field, choose “Own for Chart Radar”.

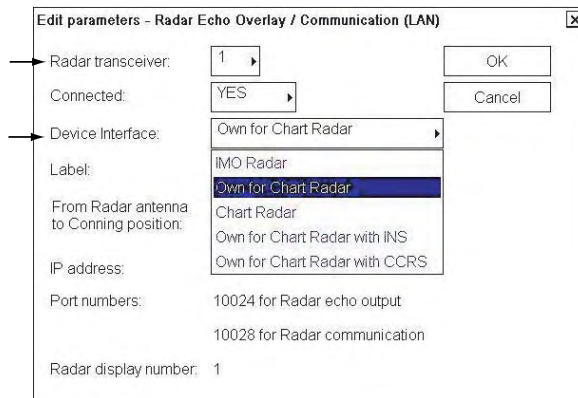

15. Click OK to close the dialog box.  
16. Turn the radar off and on again.

## 3.4 Initializing Tuning

1. Transmit the radar on 48 nm range and rotate the GAIN knob to show 70-80% of the gain bar.
2. Roll the trackball to choose the MENU box at the right side of the screen and then push the left button.
3. Roll the wheel to choose Echo and then push the wheel.

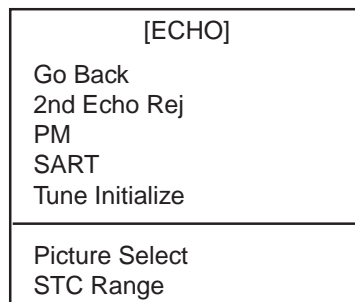

*ECHO menu*

4. Roll the wheel to choose Tune Initialize.
5. Push the wheel to initialize automatic tuning.  
After a while, echoes appear on the screen.

## 3.5 Heading Alignment

You have mounted the antenna unit facing straight ahead in the direction of the bow. Therefore, a small but conspicuous target dead ahead visually should appear on the heading line (zero degrees).

In practice, you will probably observe some small bearing errors on the display because of the difficulty in achieving accurate initial positioning of the antenna unit. The following adjustment will compensate for this error.

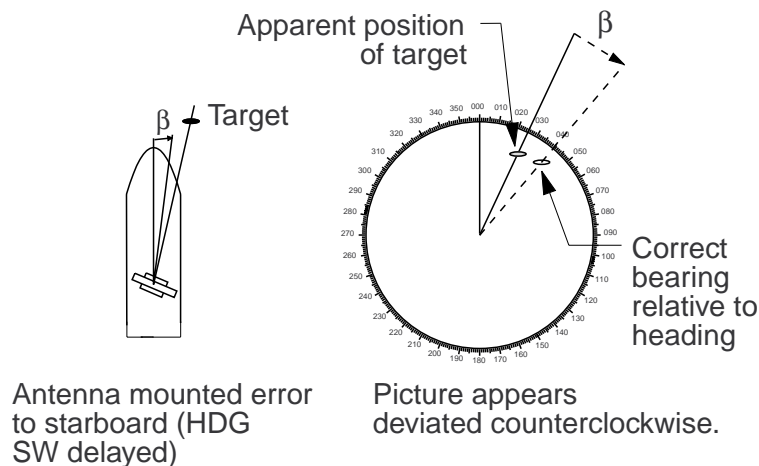
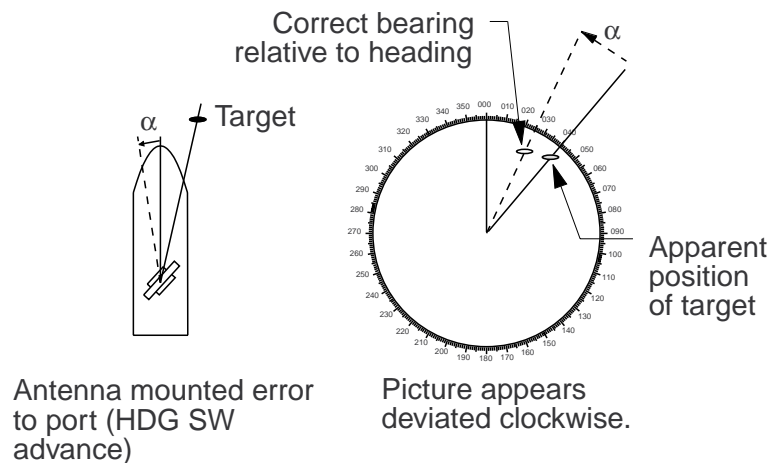

### *Heading alignment*

1. Select a stationary target echo at a range between 0.125 and 0.25 nm, preferably near the heading line.
2. Operate the EBL control to bisect the target echo.
3. Read the target bearing.

### 3. SETTING AND ADJUSTMENT

4. Measure the bearing of the stationary target on the navigation chart and calculate the difference between actual bearing and apparent bearing on the radar screen.
5. Press the [MENU] key to show the main menu.
6. Insert the authorization key disk (supplied).
7. Roll the wheel to choose “Initial Settings”.
8. Rotate the trackball to place the cursor on the ► mark. The “Initial Settings” menu appears.
9. Roll the wheel to choose “Radar Initialize” and click the wheel to show “Radar Initialize” menu and choose “Page 1”.

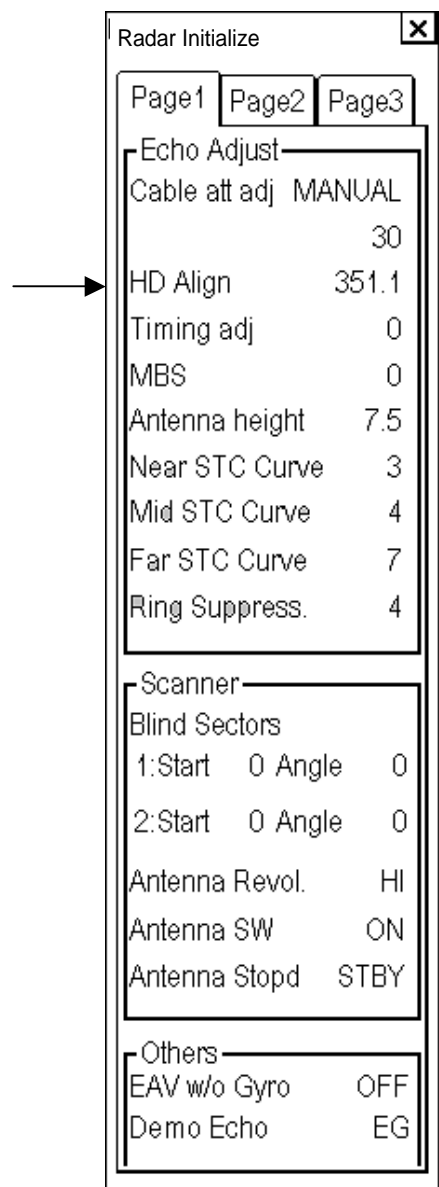

10. Place the cursor on a value of “HD Align” option. The color of the numeric value changes.
11. Roll the wheel to set the value measured at step 4 and click the left button. The setting range is 0 to 359.9°.
12. Confirm that the target echo is displayed at correct bearing on the screen.

## 3.6 Sweep Timing

Sweep timing differs with respect to the length of the signal cable between the antenna unit and the processor unit. Adjust sweep timing at installation to prevent the following symptoms:

- The echo of a “straight” target (for example, pier), on the 0.125 nm range, will appear on the display as being pulled inward or pushed outward. See Figure below.
- The range of target echoes will also be incorrectly shown.

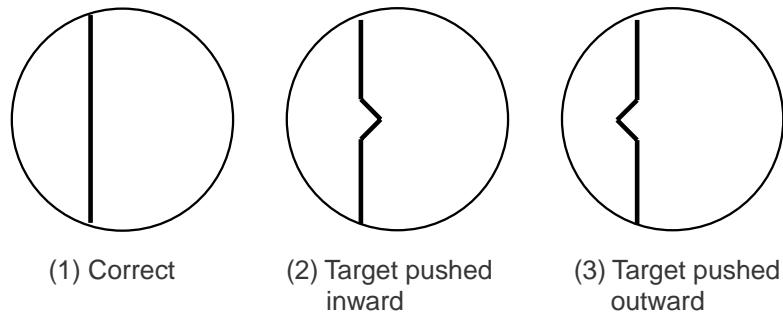

*Examples of correct and incorrect sweep timings*

1. Transmit on the 0.125 nm range.
2. Adjust radar picture controls to display picture properly.
3. Select a target echo which should be displayed straightly.
4. Place the cursor on a value of the “Timing adj” on the “Radar Initialize” menu.

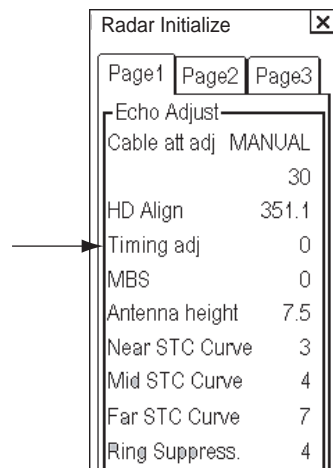

5. Rotate the wheel to set a suitable value and click the left button, which causes the target to be displayed straightly. The setting range is 0 to 4095.

## 3.7 Suppressing Main Bang

If main bang appears at the screen center, suppress it as follows.

1. Transmit the radar on a long range and then wait ten minutes.
2. Adjust gain to show a slight amount of noise on the display.
3. Select the 0.125 nm range. Adjust sea clutter control to suppress sea clutter.
4. Roll the wheel to choose the MBS on the INITIALIZE / Page 1 / Echo Adjust menu (see previous page).
5. Rotate the wheel to set a suitable value and click the left button so that the main bang disappears. The setting range is 0 to 255.

## 3.8 Other Settings

### Echo Adjust menu setting

Open the Echo Adjust menu as described on previous page.

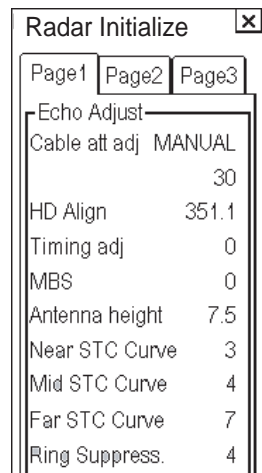

Radar Initialize		
Page1	Page2	Page3
- Echo Adjust		
Cable att adj	MANUAL	
	30	
HD Align	351.1	
Timing adj	0	
MBS	0	
Antenna height	7.5	
Near STC Curve	3	
Mid STC Curve	4	
Far STC Curve	7	
Ring Suppress.	4	

### Cable att adj

Before adjusting, set the radar as follows:

IR: 2, ES: off, EAV: off, 24nm range, long pulse

(Same as default setting of PICTURE1)

To adjust the cable attenuation manually, choose MANUAL and click the left button. Choose a value below the letter of MANUAL and rotate the wheel so that noise just appears on the screen when the gain is set to 80. Default setting is 30 for the antenna cable length of 15m. The setting range is 0 to 73.

To adjust automatically, choose AUTO and click the left button. It takes about five minutes to complete the adjustment, after which the radar goes into stand-by.



**Antenna height**

Select height (m) of the radar antenna unit from the sea surface among 5, 7.5, 10, 15, 20, 25, 30, 35, 40, 45 and "more 50 m".

**Near STC, Mid STC and far STC**

Use the default setting. Change the setting if desired according to sea condition.

**Ring Suppression**

This is mainly used to remove "ring" noise which appears in the waveguide-type radar. Adjust so the rings disappear at the range of 0.125 nm. The setting range is 0 to 255.

**Scanner setting**

Open the "Radar Initialize" menu to show scanner menu.

Radar Initialize	
Page1	Page2
-Echo Adjust-	
Cable att adj	MANUAL
	30
HD Align	351.1
Timing adj	0
MBS	0
Antenna height	7.5
Near STC Curve	3
Mid STC Curve	4
Far STC Curve	7
Ring Suppress.	4
-Scanner-	
Blind Sectors	
1:Start	0 Angle 0
2:Start	0 Angle 0
Antenna Revol.	HI
Antenna SW	ON
Antenna Stopd	STBY
-Others-	
EAV w/o Gyro	OFF
Demo Echo	EG

### 3. SETTING AND ADJUSTMENT

#### **Blind Sector 1 and Blind Sector 2**

Set area (up to 2) where no radar pulses will be transmitted. For example, set the area where an interfering object at the rear of the scanner would produce a dead sector (area where no echoes appear) on the display. To enter an area, enter start bearing relative the heading and dead sector angle. To erase the area, enter 0 for both the START and ANGLE sections. The setting range of START is 0 to 359° and ANGLE is 0 to 180°.

**Note:** The blind sector setting should be done after the heading alignment (see section 3.5).

#### **Antenna Revol.**

This menu item is used for 42 rpm antenna unit. The default is AUTO, where antenna revolution speed is high for short range setting and low speed for long range setting. When LO is selected, the antenna always rotate in 36 rpm, and HI, 42 rpm.

#### **Antenna SW and Antenna Stopd**

This is used for antenna maintenance by serviceman.

### **INSTALLATION menu setting**

Open the Installation menu by clicking “Page 2” tab on the “Radar Initialize” menu.

The screenshot shows a window titled "Radar Initialize" with a close button (X) in the top right corner. Below the title bar are three tabs: "Page1", "Page2", and "Page3". The "Page2" tab is selected. The main content area is divided into two sections: "Installation" and "Own Ship Info".

Installation	
Radar Number	1
Radar	MAIN TOP
Model	25 DOWN
On Time	13497.6
TX Time	11888.9
PM Gain Adj	1

Own Ship Info	
Length	240
Width	32
Scanner, bow	120
Scanner, port	16
GPS1, bow	120
GPS1, port	16
GPS2, bow	200
GPS2, port	26
Conning, bow	120
Conning, port	16

**Radar Number**

For multiple radar system using the network hub, set number (name) of the radar.

**Radar**

Set antenna position of the radar to easily distinguish the radar configuration among MAIN TOP, MAIN 2nd, MAIN 3rd, AFT, PORT STRD and FORE.

**Model**

Confirm the model of your radar. If the setting of this item is different from your model (combination of the antenna unit), the radar functions abnormally.

25 DOWN: For FCR-2827W

30 DOWN: For FCR-2837SW

**On Time and TX Time**

These items show number of hours the radar has been turned on and transmitted, respectively. Value can be changed; for example, after replacing magnetron TX Time can be reset to 0.

**PM Gain Adj**

Note: If you install the Performance Monitor PM-31 at field, see section 4.2 on page 4-9.

When you choose this item, the radar setting changes as follows.

RANGE:	24 NM
PULSE:	LONG
BLIND SECTOR:	OFF
STC:	OFF by Manual
RAIN:	OFF by Manual
ECHO AVERAGE:	OFF
VIDEO CONTRAST:	B2
TUNE:	AUTO

1. Adjust the GAIN control so that a slight amount of white noise appears on the screen. Arcs for performance monitor appear on the screen (Fig.1).
2. Adjust PM Gain Adj so that outer arc just disappears (Fig.2). The setting range is 0 to 255.

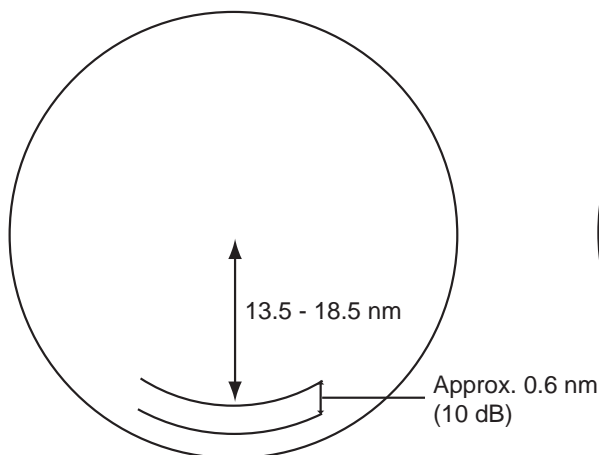

Fig.1

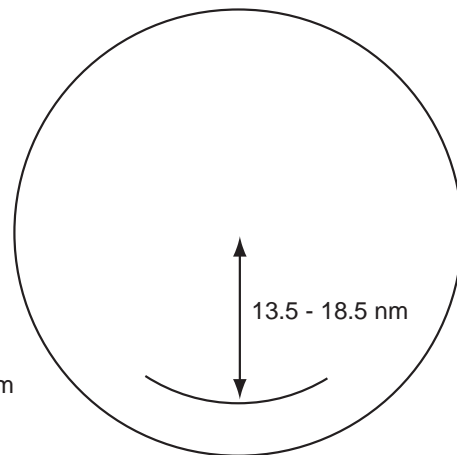

Fig.2

### 3. SETTING AND ADJUSTMENT

## OWN SHIP INFO menu setting

Open the Own Ship Info menu by clicking "Page 2" tab on the "Radar Initialize" menu.

The screenshot shows a window titled "Radar Initialize" with three tabs: "Page1", "Page2", and "Page3". The "Page2" tab is selected. The window is divided into two sections: "Installation" and "Own Ship Info".

Installation	
Radar Number	1
Radar	MAIN TOP
Model	25 DOWN
On Time	13497.6
TX Time	11888.9
PM Gain Adj	1

Own Ship Info	
Length	240
Width	32
Scanner, bow	120
Scanner, port	16
GPS1, bow	120
GPS1, port	16
GPS2, bow	200
GPS2, port	26
Conning, bow	120
Conning, port	16

### Length and Width

To inscribe own ship shape on the screen when you choose it on the menu, enter length and width of the ship. The setting ranges are as follows.

Length: 0 to 999 m

Width: 0 to 998 m (even value)

### Scanner bow and Scanner port

Enter the antenna position from the bow and port sides

Bow: 0 to 999 m

Port: 0 to 999 m

### GPS 1 bow, GPS 1 port / GPS 2 bow, GPS 2 port

These items are needed for AIS information. Enter the GPS antenna position from the bow and port sides. The setting ranges are the same as above.

### Conning bow and Conning port

Enter the conning position in the wheelhouse from the bow and port sides. The setting ranges are the same as above.

When you set the display reference point to the conning position, these values are used to correct the radar antenna position.

## TT PRESET menu setting

The screenshot shows the 'Radar Initialize' menu with three pages. Page 1 is selected and displays the following settings:

TT Preset	
TT Data Output	TTM
	TRUE 38400
Max Range	24 NM
Echo Level	1
QV Display	OFF

ACQ Preset	
Land Size	1600
Ant Select	XN12AF
Auto ACQ Corre	3
Auto ACQ Weed	1

Track Preset	
Gate Size	S
Filter	1
Lost Count	1
Max Speed	40
Start Time TGT VECT	
Mode	TIME
Sec	20
Scan	

At the bottom of the menu is a 'Defaults' button.

### TTM OUTPUT

Set the output format of tracked targets among OFF, REL and TRUE.

- OFF: No output
- REL (relative): Target bearing from own ship, degree relative.  
Target course, degree relative.
- TRUE: Target bearing, degree true.  
Target course, degree true.

### MAX RANGE

Choose the ARPA tracking range, 24 or 32 nm.

### ECHO LEVEL

Set the detection level of echoes. The setting range is 1 to 31.

### QV DISPLAY

- OFF: Normal picture
- ON: Quantized picture; always off at power on

### LAND SIZE

Set the land size in units of 100 m. The setting range is 100 to 3000 m. An echo more than the setting is recognized as land echo.

### 3. SETTING AND ADJUSTMENT

#### **ANT SELECT**

Set the antenna radiator type of your radar among XN12AF, XN20AF, XN24AF, XN4A, XN5A, SN30AF, SN36AF, SN4A, or SN5A.

#### **AUTO ACQ CORRE**

Set the correlation count of automatic acquisition. The setting range is 3 to 10.

#### **AUTO ACQ WEED**

Set the cancel count of automatic acquisition. The setting range is 1 to 5.

#### **GATE SIZE**

Set the gate size among S, M, L, or LL.

#### **FILTER**

Set the filter response function. The setting range is 1 to 4.

#### **LOST COUNT**

Set the lost count. The setting range is 1 to 20.

#### **MAX SPEED**

Set the maximum tracking speed. The setting range is 40 to 150.

#### **START TIME TGT VECT**

Choose time which a vector appears after acquisition, TIME or SCAN and set seconds or scan counts.

#### **Default button**

Reset the above setting to the factory setting.

## 3.9 Saving and Restoring Radar Initialize Parameters

### Saving or restoring on hard disk of Chart radar

Radar initialize parameters can be saved on hard disk of Chart processor when you have set correct operative parameters. They can then be restored when ever it is required.

To save parameters:

1. Insert the “Authorizing key disk” to the chart processor unit.  
Note that the installation parameters have limited access which is controlled by the Authorization key disk supplied.
2. Press the MENU key on the control unit to show the Main Menu.
3. Roll the wheel to choose “Initial Settings” to show INITIAL SETTINGS dialog box.

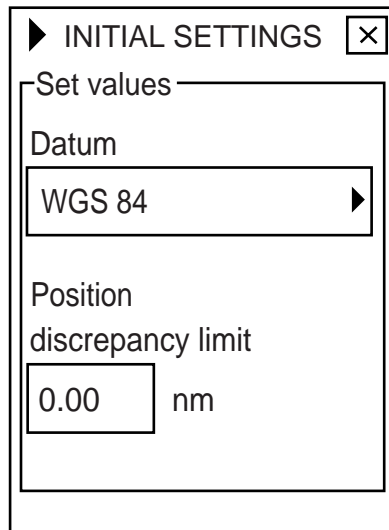

4. Rotate the trackball to place the cursor on the ► mark. The “Initial Settings” menu appears.

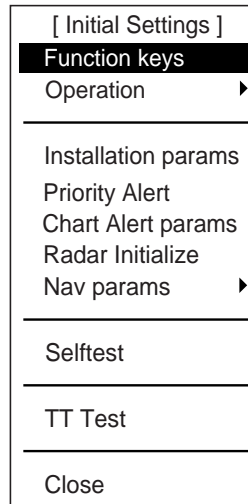

### 3. SETTING AND ADJUSTMENT

5. Roll the wheel to choose “Radar Initialize” and click the wheel to show INITIALIZE menu.

The screenshot shows a window titled "Radar Initialize" with a close button (X) in the top right corner. Below the title bar are three tabs: "Page1", "Page2" (which is selected and highlighted with a dotted border), and "Page3". The main content area is divided into two sections: "Installation" and "Own Ship Info".

Installation	
Radar Number	1
Radar	MAIN TOP
Model	25 DOWN
On Time	2683.4
TX Time	2264.8
PM Gain Adj	0

Own Ship Info	
Length	250
Width	30
Scanner, bow	0
Scanner, port	15
GPS1, bow	125
GPS1, port	15
GPS2, bow	125
GPS2, port	15
Conning, bow	125
Conning, port	15

6. Rotate the trackball to place the cursor on the ► mark. The “Radar Initialize” menu appears.

The screenshot shows a vertical menu titled "[ Radar Initialize ]". The menu items are "Save", "Restore", and "Close". The "Save" option is currently selected, indicated by a thick black horizontal bar behind the text.

7. Select “Save” to make backup to Hard disk

Restore is done by proceeding steps 1-6 and selecting “Restore” in step 7.



## **Save or restoring on backup media**

To make a backup copy of radar initialize parameters for later use, see instructions below.

1. Select the ECDIS mode.
2. Press the MENU key on the control unit to show the Main Menu.
3. Roll the wheel to choose "Initial Settings" to show INITIAL SETTINGS dialog box.
4. Rotate the trackball to place the cursor on the ► mark to show the "Initial Settings" menu.
5. Roll the wheel to choose "Backup and Restore" and click the wheel to show BACKUP & RESTORE dialog box.
6. Do the instruction as follows.

### **Backing up a file to a floppy disk**

You can make a backup from an original file to a floppy disk. To make a backup of a file to a floppy disk, insert a floppy disk in the disk drive, then do the following:

1. Choose "installation Parameter" file category.
2. Choose "Radarinitvalues" file from the Hard Disk field.
3. Choose desired Drive from the Drive field.
4. Click the Backup button.

### **Reading a file from a floppy disk**

You can restore a file with one stored on a floppy disk. To restore a file stored on a floppy disk, do the following:

1. Choose "Installation Parameter" file category.
2. Choose desired Drive from the Drive field.
3. Choose "Radarinitvalues" file from the Backup Device field.
4. Click the Restore button.
5. Press the MENU key on the control unit to show the Main Menu.
6. Roll the wheel to choose "Initial Settings" to show INITIAL SETTINGS dialog box.
7. Rotate the trackball to place the cursor on the ► mark to show the "Initial Settings" menu.
8. Roll the wheel to choose "Radar Initialize" and click the wheel to show Radar Initialize dialog box.
9. Rotate the trackball to place the cursor on the ► mark to show the "Radar Initialize" menu.
10. Select Restore to restore from Hard disk.

### 3.10 Parameters

Open the Installation Parameter dialog box as described on page 3-7.

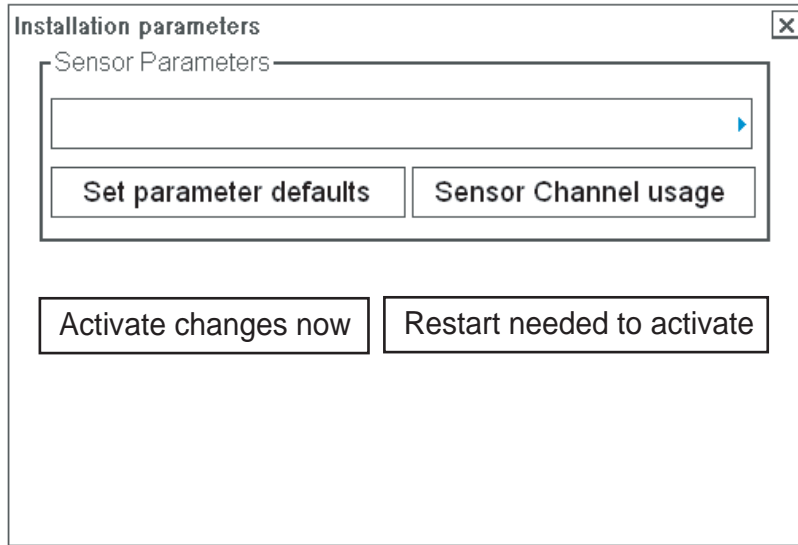

There are several buttons in this dialog box, and these are described below:

#### Set parameters default

This restores Installation parameters which are saved as a backup copy by service personnel. Use this function if you are not sure about Installation parameters values.

#### Activate changes now

This activates changes and closes the Installation parameters dialog box.

#### Restart needed to activate

This closes Installation parameters dialog box and activates changes after restarting the radar.

#### Sensor Channel Usage

This shows how the serial channels of LAN adapters are configured and which analog sensors are connected to the system through the B adapter.

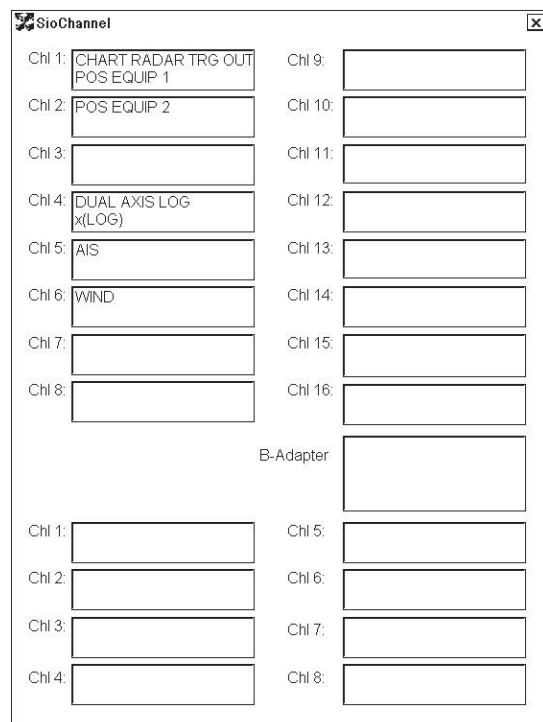

**What happens after pressing OK**

After pressing OK, you may get one of the following alarms.

**"4000 No Sensor parameters"**: The Sensor Parameters are corrupted. Use backup of Parameters.

**"3000 Param change disabled"**: The FCR-2107/2807 cannot accept change of parameters if Kalman Filter is ON.

**Opening each parameter dialog box**

1. Click ► mark on the drop-down list.
2. Choose an item you want to set, by scrolling the list.

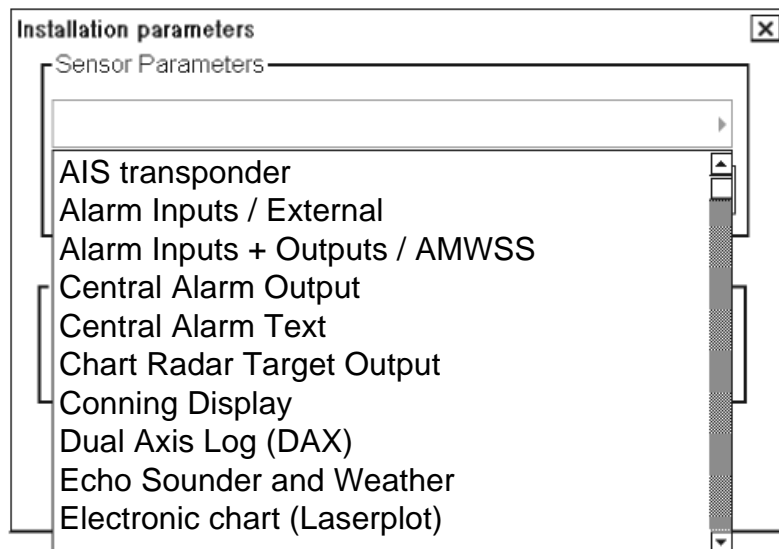

### 3. SETTING AND ADJUSTMENT

#### General setting

If there is no optional B adapter, select Connected = NO.

**Edit parameters - General** [X]

Ship's Name: ChartRadar1 [OK] [Cancel]

Sensor Message interval: 2 x 100 ms

B-Adapter SIO Channel: 13 ▾

B-Adapter connected: NO ▾

Trim Indicator: Disconnected ▾

Docking DISP SPD Vector MAX: 4.0 kn

From Center Position to

Bow Position: 100 m (+Bow, -Stern) Length: 200 m

Stern Position: -100 m (+Bow, -Stern)

Dual Axis Log Position: 70 m (+Bow, -Stern)

Conning Position: 60 m (+Bow, -Stern)

Side Position: 15 m Breadth: 30 ▾ m

Sidewise Conning Position: 10 m (+Stbd, -Port)

Total height from keel to mast: 40 m

If there is an optional B adapter, select Connected = YES.

**Edit parameters - General** [X]

Ship's Name: ChartRadar1 [OK] [Cancel]

Sensor Message interval: 2 x 100 ms

B-Adapter SIO Channel: 13 ▾

B-Adapter connected: YES ▾

Trim Indicator: Disconnected ▾

Docking DISP SPD Vector MAX: 4.0 kn

From Center Position to

Bow Position: 100 m (+Bow, -Stern) Length: 200 m

Stern Position: -100 m (+Bow, -Stern)

Dual Axis Log Position: 70 m (+Bow, -Stern)

Conning Position: -60 m (+Bow, -Stern)

Side Position: 15 m Breadth: 30 ▾ m





Sidewise Conning Position: 10 m (+Stbd, -Port)

Total height from keel to mast: 40 m

#### **Notes:**

- Center position is geometrical center of the ship.
- Conning Position is the point of observation.

3. SETTING AND ADJUSTMENT

-  Radar Antenna Position
-  Conning Position
-  GPS Antenna Position
-  Dual Axis Log Position

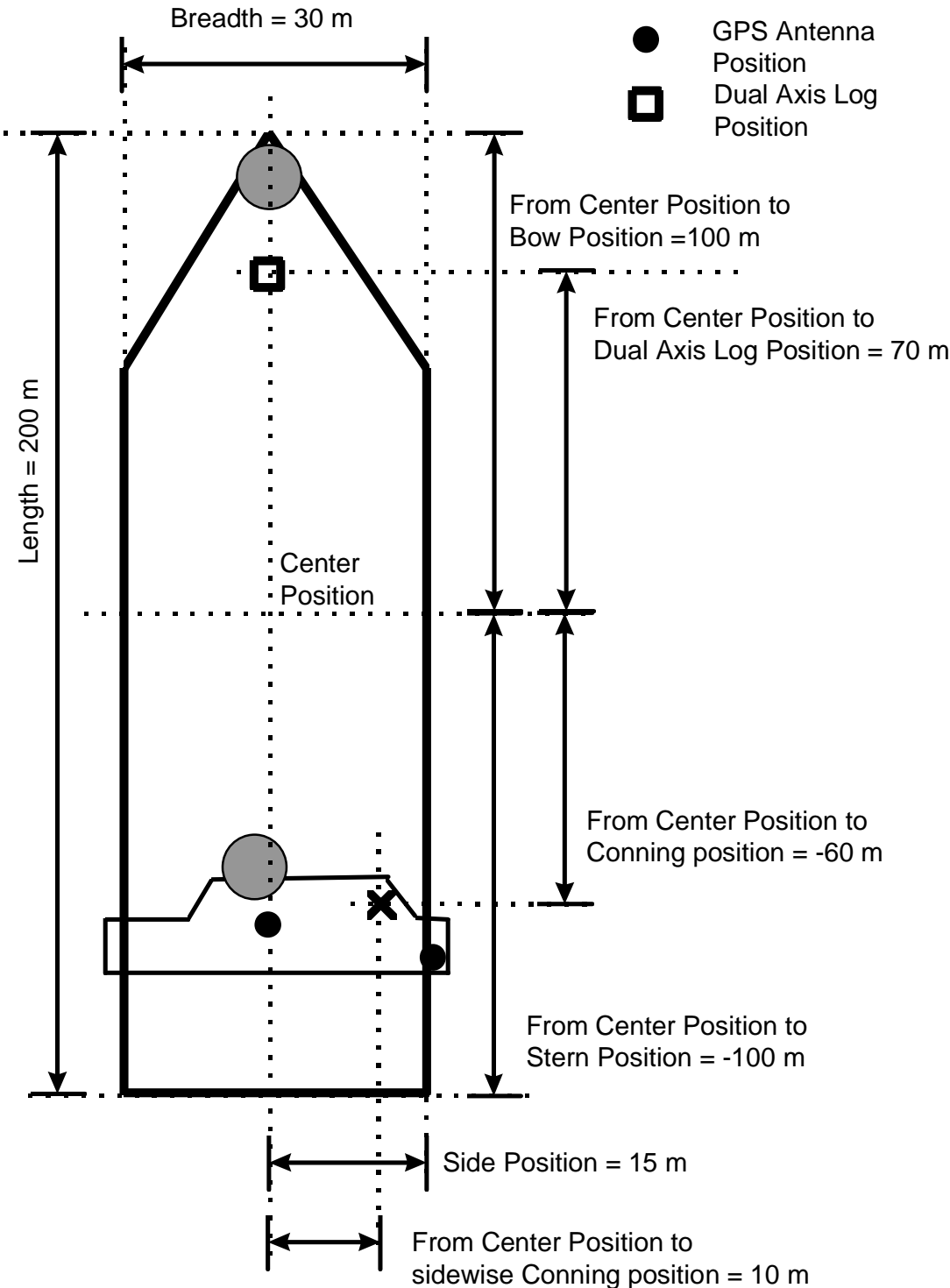

### 3. SETTING AND ADJUSTMENT

#### Gyro 1 setting

Settings when Radar CPU is receiving data in AD-10 format.

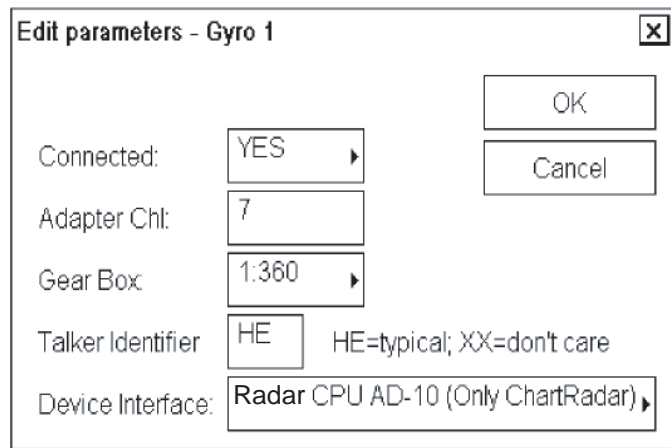

The dialog box 'Edit parameters - Gyro 1' contains the following settings:

- Connected: YES
- Adapter Chl: 7
- Gear Box: 1:360
- Talker Identifier: HE (with note: HE=typical; XX=don't care)
- Device Interface: Radar CPU AD-10 (Only ChartRadar)

Buttons: OK, Cancel

Settings when Radar CPU is receiving data in serial format.

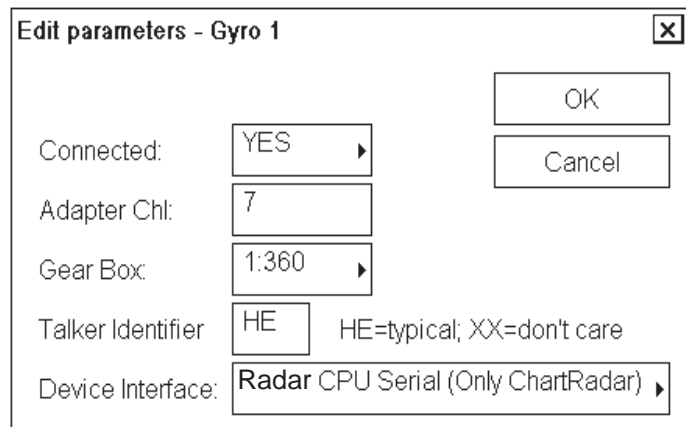

The dialog box 'Edit parameters - Gyro 1' contains the following settings:

- Connected: YES
- Adapter Chl: 7
- Gear Box: 1:360
- Talker Identifier: HE (with note: HE=typical; XX=don't care)
- Device Interface: Radar CPU Serial (Only ChartRadar)

Buttons: OK, Cancel

#### Gyro 2 setting

Gyro 2 is not connected.

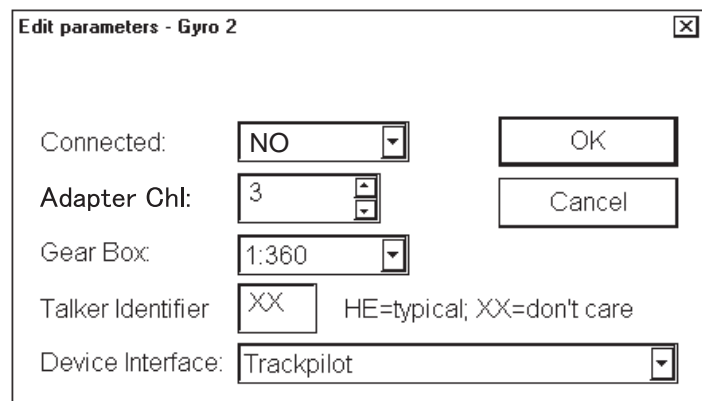

The dialog box 'Edit parameters - Gyro 2' contains the following settings:

- Connected: NO
- Adapter Chl: 3
- Gear Box: 1:360
- Talker Identifier: XX (with note: HE=typical; XX=don't care)
- Device Interface: Trackpilot

Buttons: OK, Cancel

**Log setting**

Settings when log  
is single axis  
speed log  
transmitting  
IEC-61162-1.  
Message used is  
VBW.

**Edit parameters - Log** [X]

Collected: YES [▶]

Adapter Chl: 8

Device Interface: IEC 61162-1 (\$xxVBW) [▶]

OK

Cancel

Talker Identifier: XX VD=typical; XX=don't care

**Notes:**

- Talker identifier can be defined for IEC 61162-1 (typical talker for log is VD). If talker identifier is defined as XX, then it is ignored.

### 3. SETTING AND ADJUSTMENT

#### Dual-axis log setting

Settings when using IEC-61162-1.

**Edit parameters - Dual Axis Log (DAX)** [X]

Connected: YES [▶] [OK]

Adapter Channel: 8 [Cancel]

Device Interface: IEC 61162-1 (\$xVBW) [▶]

Sign Positive: for Astern [▶] (longitudinal speed)

Sign Positive: for Port [▶] (transversal speed)

Use Sign Positive parameters to change polarity of speed components

Status Flag Check: Check - only "A", "B" or "W" accepted [▶]

Talker Identifier: VD [VD=typical; XX=don't care]

Settings when no dual-axis log is available.

**Edit parameters - Dual Axis Log (DAX)** [X]

Connected: NO [▶] [OK]

Adapter Channel: 8 [Cancel]

Device Interface: IEC 61162-1 (\$xVBW) [▶]

Sign Positive: for Astern [▶] (longitudinal speed)

Sign Positive: for Port [▶] (transversal speed)

Use Sign Positive parameters to change polarity of speed components

Status Flag Check: Check - only "A", "B" or "W" accepted [▶]

Talker Identifier: VD [VD=typical; XX=don't care]

#### **Notes:**

- Talker identifier can be defined for IEC 61162-1 (typical talker for dual axis log is VD). If talker identifier is defined as XX, then it is ignored.
- IEC 61162-1 uses VBW.
- If you selected VBW message, then bottom track is available from dual-axis log and water track could be available from log.
- DS-30 is a special device Furuno DS-30.



**Radar Echo Overlay / communication (LAN)**

**Edit parameters - Radar Echo Overlay / communication (LAN)**

Radar transceiver: 1

Connected: YES

Device Interface: Own for Chart Radar

Label: FIRST

From Radar antenna to Conning position: 99 m (+Stbd, -Port)  
40 m (+Bow, -Stern)

IP address: 172.31.3.6

Port numbers: 10024 for Radar echo output  
10028 for ARPA communication

Radar display number: 1

OK

Cancel

**Radar transceiver:** For multiple radar system, enter a radar system number among 1, 2, 3 and 4.

**Connected:** To connect above radar, choose YES.

**Device Interface:** Choose a device interface among “Own for Chart Radar”, “Chart Radar”, “IMO Radar”, “Own for Chart Radar with INS” and “Own for Chart Radar with CCRS”.

**Label:** Enter appropriate name for above radar. For example, FIRST, SECOND, etc.

**From Radar antenna to Conning position:**  
Enter a horizontal distance (m) between conning position and antenna of above radar.

### 3. SETTING AND ADJUSTMENT

#### **Example1**

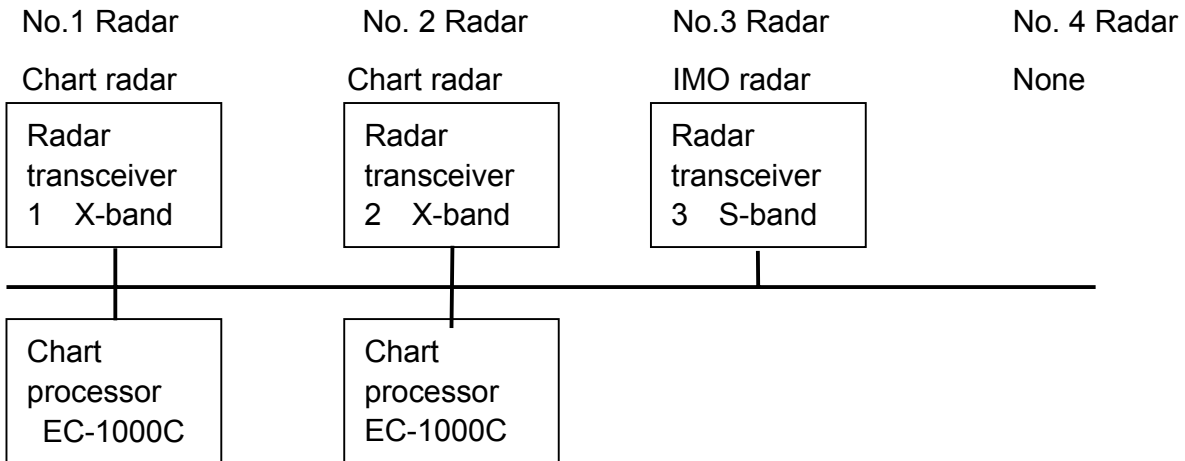

#### Setting on EC-1000C of the chart radar 1

Own radar is No.1 and chart radar.  
So the settings for “Radar transceiver”,  
“Connected”, “Device interface” are  
shown in the figure right.  
You can put any name on the Label to  
distinguish from other radar.  
Enter actual distance (m) from No.1  
radar antenna to the conning position.

Radar transceiver:	<input type="text" value="1"/>
Connected:	<input type="text" value="YES"/>
Device Interface:	<input type="text" value="Own for Chart Radar"/>
Label:	<input type="text" value="Xband1"/>
From Radar antenna to Conning position:	<input type="text" value="7"/> m (+Stbd, -Port)
	<input type="text" value="-5"/> m (+Bow, -Stern)

No. 2 radar is x-band chart radar.  
So, the setting is shown in the figure  
right.

Radar transceiver:	<input type="text" value="2"/>
Connected:	<input type="text" value="YES"/>
Device Interface:	<input type="text" value="Chart Radar"/>
Label:	<input type="text" value="Xband2"/>
From Radar antenna to Conning position:	<input type="text" value="1"/> m (+Stbd, -Port)
	<input type="text" value="2"/> m (+Bow, -Stern)

Radar transceiver:	<input type="text" value="3"/>
Connected:	<input type="text" value="YES"/>
Device Interface:	<input type="text" value="IMO Radar"/>
Label:	<input type="text" value="Sband3"/>
From Radar antenna to Conning position:	<input type="text" value="2"/> m (+Stbd, -Port)
	<input type="text" value="5"/> m (+Bow, -Stem)

No. 3 radar is S-band IMO radar.  
So the setting is shown above.

Radar transceiver:	<input type="text" value="4"/>
Connected:	<input type="text" value="NO"/>
Device Interface:	<input type="text" value=""/>
Label:	<input type="text" value="1"/>
From Radar antenna to Conning position:	<input type="text" value="0"/> m (+Stbd, -Port)
	<input type="text" value="0"/> m (+Bow, -Stem)

There is no No. 4 radar.  
So the setting is shown above.

### Example 2

Below is an example where FCR-2xx7 and FEA-2x07 are configured to use shared route information.

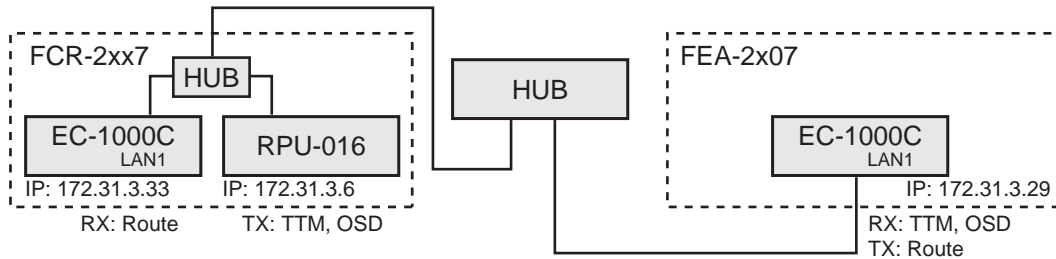

**Edit parameters - Radar Echo Overlay / Communication (LAN)** ✕

Radar transceiver:	<input type="text" value="1"/>	<input type="button" value="OK"/>
Connected:	<input type="text" value="YES"/>	<input type="button" value="Cancel"/>
Device Interface:	<input type="text" value="Own for Chart Radar with INS"/>	
Label:	<input type="text" value="ARPA1"/>	
From Radar antenna to Conning position:	<input type="text" value="0"/> m (+Stbd, -Port)	
	<input type="text" value="0"/> m (+Bow, -Stem)	
IP address:	172.31.3.6	
Port numbers:	10024 for Radar echo output	
	10028 for Radar communication	
Radar display number:	1	
INS IP Address:	172.31.3.	<input type="text" value="29"/>
Port numbers:	15003 for INS communication	

Note that you need to define as follows,

- Device interface: **“Own for Chart Radar with INS”**

### 3. SETTING AND ADJUSTMENT

- INS IP Address: **172.31.3.xx** (IP address is FEA-2x07 LAN IP Address)

#### Position equipment

An example of DGPS receiver which is able to send IEC 61162-1 Ed. 2 messages (includes information about Datum of output position).

**Edit parameters - Positioning Equipment 1**

Connected: YES Device Name: GPS 1  
 Adapter Chl: 2 Device Type: DGPS  
 Device Interface: IEC 61162-1 ed2 Weight Factor: 0.4  
 Identification: GGA+VTG Cmg Delay: 0 s  
 Talker Identifier: GP XX=don't care Offsets from Antenna position to Conning position: 0.0 m (+Stbd, -Port)  
 Speed Talker ID: XX XX=don't care 0.0 m (+Bow, -Stem)  
 Device Datum: WGS 84

Roll and Pitch Receive:	Disabled	Weight Factor	dRMS[m]	4dRMS[m]
IEC 61162-1 Transmit checksum	Used	0.01	1000	4000
\$ char included in transmit checksum	Not included	0.05	200	800
		0.07	143	571
		0.1	100	400
		0.2	50	200
		0.4	25	100
		0.6	17	67
		0.8	12	50

OK Cancel

Right is an example of GPS receiver with ignored talker identifiers for both GLL and VTG messages.

**Edit parameters - Positioning Equipment 1**

Connected: YES Device Name: GPS  
 Adapter Chl: 2 Device Type: GPS  
 Device Interface: IEC 61162-1 ed2 Weight Factor: 0.4  
 Identification: GLL+VTG Cmg Delay: 0 s  
 Talker Identifier: GP XX=don't care Offsets from Antenna position to Conning position: 10 m (+Stbd, -Port)  
 Speed Talker ID: XX XX=don't care 5 m (+Bow, -Stem)  
 Device Datum: WGS 84

Roll and Pitch Receive:	Disabled	Weight Factor	dRMS[m]	4dRMS[m]
IEC 61162-1 Transmit checksum	Used	0.01	1000	4000
\$ char included in transmit checksum	Not included	0.05	200	800
		0.07	143	571
		0.1	100	400
		0.2	50	200
		0.4	25	100
		0.6	17	67
		0.8	12	50

OK Cancel

An example of setting for DGPS receiver which is able to send IEC 61162-1 Ed. 2 messages.

**Edit parameters - Positioning Equipment 1**

Connected:  Device Name:

Adapter Chl:  Device Type:

Device Interface:  Weight Factor:

Identification:  Cmg Delay:  s

Talker Identifier:  XX=don't care Offsets from  m (+Stbd, -Port)

Speed Talker ID:  XX=don't care Antenna position to  m (+Bow, -Stem)

Device Datum:

Roll and Pitch Receive:

Weight Factor	dRMS[m]	4dRMS[m]
0.01	1000	4000
0.05	200	800
0.07	143	571
0.1	100	400
0.2	50	200
0.4	25	100
0.6	17	67
0.8	12	50

IEC 61162-1 Transmit checksum:

\$ char included in transmit checksum:

An example of setting for Loran receiver.

**Edit parameters - Positioning Equipment 1**

Connected:  Device Name:

Adapter Chl:  Device Type:

Device Interface:  Weight Factor:

Identification:  Cmg Delay:  s

Talker Identifier:  XX=don't care Offsets from  m (+Stbd, -Port)

Speed Talker ID:  XX=don't care Antenna position to  m (+Bow, -Stem)

Device Datum:

Roll and Pitch Receive:

Weight Factor	dRMS[m]	4dRMS[m]
0.01	1000	4000
0.05	200	800
0.07	143	571
0.1	100	400
0.2	50	200
0.4	25	100
0.6	17	67
0.8	12	50

IEC 61162-1 Transmit checksum:

\$ char included in transmit checksum:

### 3. SETTING AND ADJUSTMENT

#### Notes:

- Talker identifier can be separately defined for speed and course (VTG message) and for position (GLL, GGA or PAT message). If talker identifier is defined as XX, then it is ignored.
- IEC 61162-1 ed1 or ed2: GGA uses messages VTG and GGA. Recommended for DGPS. Correct operation of a DGPS sensor requires that the system also receives VTG message. If no VTG message is received, the system thinks that there is something wrong in the DGPS and it downgrades the DGPS to an ordinary GPS sensor.
- IEC 61162-1 ed1: PAT uses messages VTG, PAT and SHR, POS. Alternative for a DGPS which also gives pitch and roll data.
- IEC 61162-1 ed1: GLL uses messages VTG and GLL. Recommended for non differential position receivers.
- IEC 61162-1 ed2: GLL uses messages VTG and GLL. Recommended for both differential and non-differential position receivers.
- IEC 61162-1 ed1: GLL Use of differential signal with GPS can be detected with GGA and SHR, POS. A device using identification GLL and device type 8 (= DGPS) will always be detected as differential regardless of receiver status.
- COG delay is the delay between own ship turning and course made good in the VTG message to detect turning. Typically values are from 0 to 15 seconds.
- Because no message has any datum indication, the user is responsible for reference system used in the position receiver. GGA message is supposed to always be in WGS-84, but unfortunately some manufacturers do not follow this standard.
- Only one of connected sensors is allowed to send ZDA message, which will be used to adjust the system clock. If time difference is larger than 5 seconds and if the system is not a part of steering (i.e., mode is not Goto Wp, Goto Track or Program Track Turn) and if the system has Kalman filter in OFF position.
- Offset from antenna position to Conning position is essential for speed, course, drift and predictor related calculation.
- Roll & pitch data may be enabled only with PAT.
- First two channels can also operate as general purpose outputs. Checksum related parameters are for outputs only. Sent messages are GLL, VTG and HDT.  
(NOTE: Output operation requires an SIF module instead on RIF module in the A adapter.
- There are two alternatives for IEC 61162-1 based interface: **ed1** and **ed2**. Ed1 was published and Ed2 was published in July 2000. The differences are new datum message (DTM) and changed content of GLL position message.
- Ed2 requires that position information (in this case GLL or GGA messages) also contain separate indication of datum used (DTM message). IMO rule state that the radar can only accept position in WGS84 datum. In practice only EPFS (for example, GPS or DGPS), which has "IEC 61162-1 Ed 2 (2000-7)" indicated in their type approval certificate can detect Datum.
- Ed2 requires that the GLL message includes a quality indicator i.e., the GLL message can indicate if position is based on standard GPS or differential GPS.

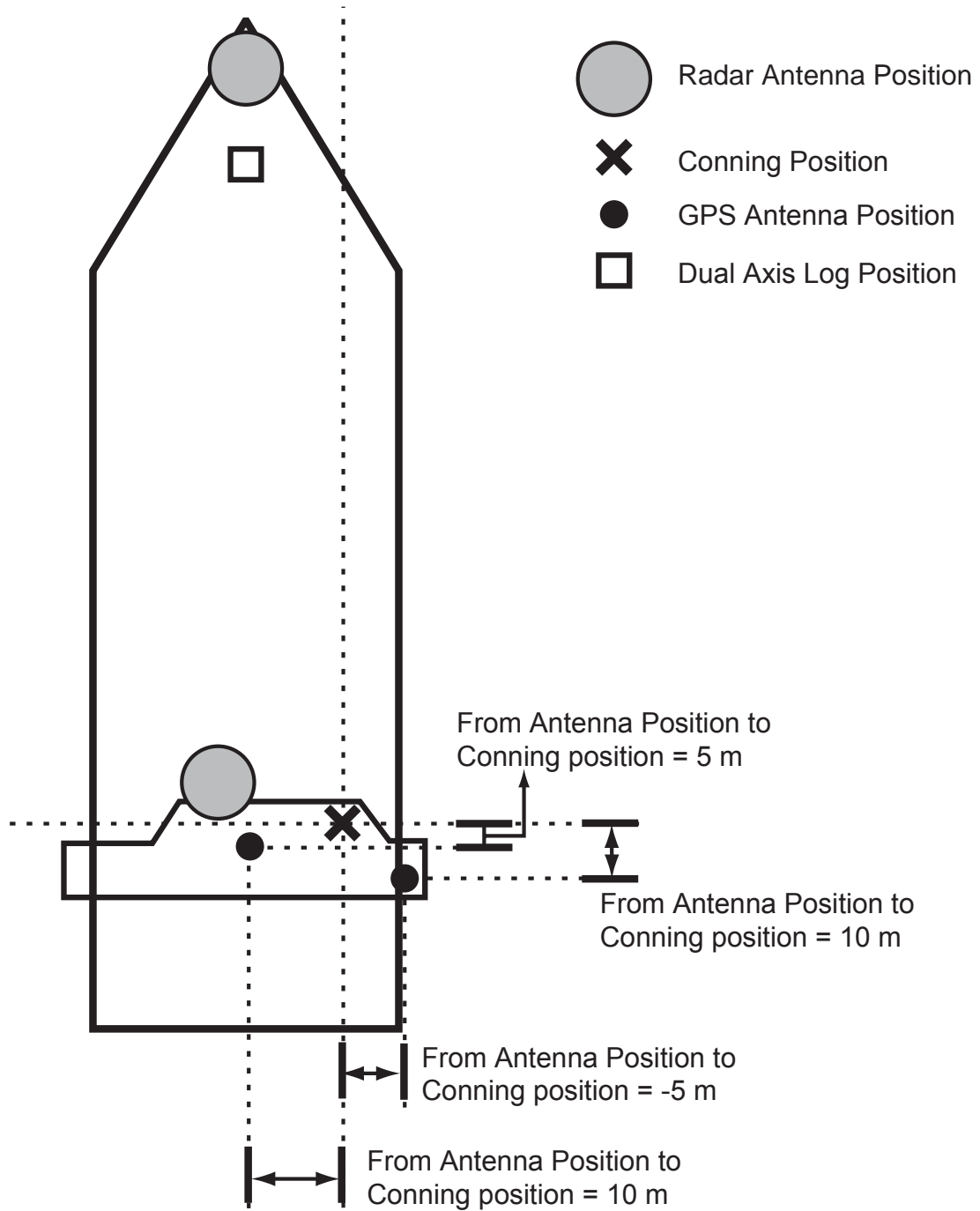

**Note for service engineer:**

If the vessel has main and backup system, set proper antenna offset for both systems. Keep in mind that they are two independent and separate systems, but they should share common antenna offset in case that they are connected to the same position antenna.

### 3. SETTING AND ADJUSTMENT

#### **Echo Sounder and Weather**

**Edit parameters - Echo Sounder and Weather** ✕

OK Cancel

	Echosounder (BOW)	Echosounder (AFT)	Water Current
Connected	YES ▶	YES ▶	YES ▶
Device Interface	IEC 61162-1 (\$xDBT) ▶	IEC 61162-1 (\$xDBT) ▶	IEC-61162-1 (\$xVDR) ▶
Adapter Chl	14	16	12
Talker Identifier	SD	SD	XX
Median Filter	NO ▶	NO ▶	
Sensor to keel distance	0 m	0 m	

	Water Temperature	Air Temperature	Air Pressure	Air Humidity
Connected:	NO ▶	NO ▶	NO ▶ mbar ▶	NO ▶
Device Interface:	IEC-61162-1 (\$xMTW) ▶	Analog (uses B-Adapter) ▶	Analog (uses B-Adapter) ▶	Analog (uses B-Adapter) ▶
Adapter Chl:	10	8	6	4
Output	0.00 V (at 0 °C)	0.00 V (at 0 °C)	0.00 V (at 800 hPa)	0.00 V (at 0 %)
Output per Volt:	0.00 °C / Volt	2.00 °C / Volt	0.00 hPa/Volt	0.00 %/Volt
Prefiltering:	0 ▶	0 ▶	0 ▶	0 ▶
B-Adapter Chl:	2	3	7	5

#### **Notes: (Air Pressure)**

- Not used by this system, should have Connected = NO

#### **Notes: (Air Humidity)**

- Not used by this system, should have Connected = NO



**Wind sensor**

Here is an example of a wind sensor which is connected to LAN Adapter channel 15.

Wind modes are defined as :The wind as measured by a wind meter is known as apparent wind. If indicated wind includes speed compensation it is known as relative wind. If indicated wind includes both speed and heading compensation it is known as true wind.

**Definitions:**

- APPARENT                      Wind as measured by wind meter.
- RELATIVE                      Wind includes speed compensation.
- TRUE (=Theoretical) Wind includes both speed and heading compensations.
- TRUE (=North)                Wind includes both speed compensation and North stabilization.

**Notes:**

- Talker identifier is ignored.
- THIES in the Device Interface is a special case.
- Calculation of true from relative can only be used if wind sensor sends TRUE wind according to definition above.
- **Source of True Wind** to define what kind of wind is transmitted by weather station: "Receive (T)heoretical Wind (HDG) and Calculate True wind" is default.
- **Style of Display** to define what kind of wind is displayed on ECDIS, True wind or Relative wind.
- **Style of output to Radar** to define what kind of wind is transmitted to radar.

### 3. SETTING AND ADJUSTMENT

#### **ROT gyro**

No ROT Gyro connected:  
The system calculates from  
movement of Gyro heading.

Dialog box: Edit parameters - Rate of Turn Gyro

Connected: NO, Calculated from Gyro source

Max scale: 200

Buttons: OK, Cancel

ROT gyro value is received  
from Dolog 23 dual-axis log.

Dialog box: Edit parameters - Rate of Turn Gyro

Connected: YES

Device Type: DAX Dolog23: (\$PKDRU)

Output per Volt: -40.00 (°/min) / V

Max scale: 200

Note: Use sign of Output per Volt to change polarity of Rate of turn

Buttons: OK, Cancel

ROT gyro value is received  
from gyro connected as  
Gyro1.

Dialog box: Edit parameters - Rate of Turn Gyro

Connected: YES

Device Type: Gyro1: IEC 61162-1 (\$xROT)

Output per Volt: -40.00 (°/min) / V

Max scale: 200

Note: Use sign of Output per Volt to change polarity of Rate of turn

Buttons: OK, Cancel

**AIS**

Settings for AIS Transponder.

**Engine control**

Settings for receiving Fuel Consumption, Propeller and Main Engine Air Pressure data from engine control system manufactured by NORCONTROL (used message is \$NCDAT). Note that full use of this feature requires that you also activate Fuel Consumption, Propeller and Main Engine Air Pressure parameters, set as Engine Control.

Switch Input	In Use	Open is OFF	Fixed Use For
1	<input type="checkbox"/>	<input type="checkbox"/>	Propeller 1
2	<input type="checkbox"/>	<input type="checkbox"/>	Propeller 1
3	<input type="checkbox"/>	<input type="checkbox"/>	Propeller 2
4	<input type="checkbox"/>	<input type="checkbox"/>	Propeller 2
5	<input type="checkbox"/>	<input type="checkbox"/>	Not Used
6	<input type="checkbox"/>	<input type="checkbox"/>	Not Used
7	<input type="checkbox"/>	<input type="checkbox"/>	Not Used
8	<input type="checkbox"/>	<input type="checkbox"/>	Not Used
9	<input type="checkbox"/>	<input type="checkbox"/>	Not Used
10	<input type="checkbox"/>	<input type="checkbox"/>	Not Used
11	<input type="checkbox"/>	<input type="checkbox"/>	Not Used
12	<input type="checkbox"/>	<input type="checkbox"/>	Not Used
13	<input type="checkbox"/>	<input type="checkbox"/>	Not Used
14	<input type="checkbox"/>	<input type="checkbox"/>	Not Used
15	<input type="checkbox"/>	<input type="checkbox"/>	Not Used
16	<input type="checkbox"/>	<input type="checkbox"/>	Not Used

### 3. SETTING AND ADJUSTMENT

#### **Speed pilot**

Settings when speed pilot is **not** connected.

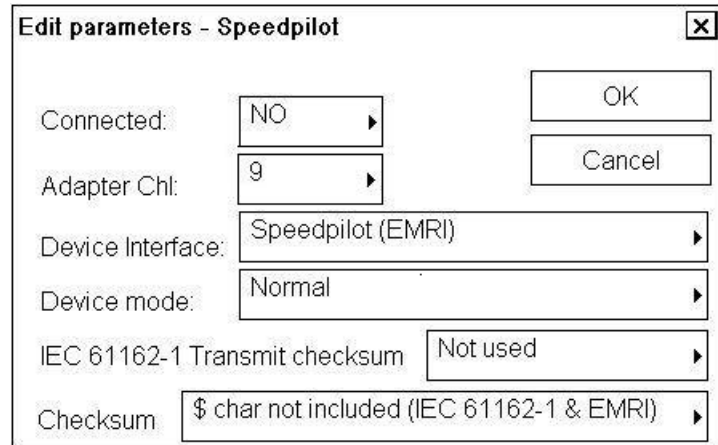

The screenshot shows a dialog box titled "Edit parameters - Speedpilot" with a close button (X) in the top right corner. The dialog contains several settings, each with a dropdown menu and a right-pointing arrow:

- Connected: NO
- Adapter Chl: 9
- Device Interface: Speedpilot (EMRI)
- Device mode: Normal
- IEC 61162-1 Transmit checksum: Not used
- Checksum: \$ char not included (IEC 61162-1 & EMRI)

On the right side of the dialog, there are two buttons: "OK" and "Cancel".

Settings when speed pilot is connected.

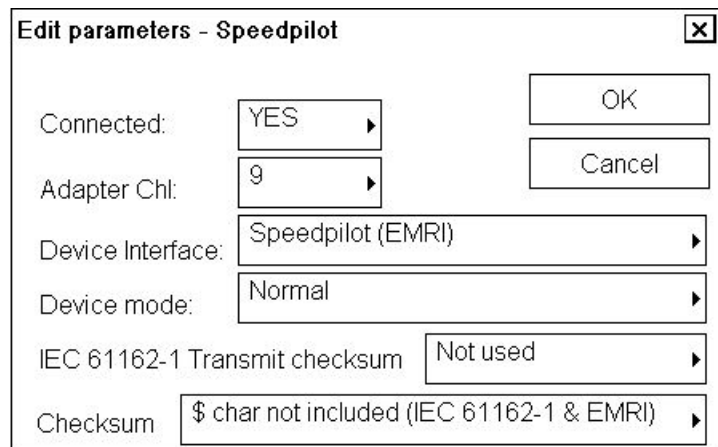

The screenshot shows a dialog box titled "Edit parameters - Speedpilot" with a close button (X) in the top right corner. The dialog contains several settings, each with a dropdown menu and a right-pointing arrow:

- Connected: YES
- Adapter Chl: 9
- Device Interface: Speedpilot (EMRI)
- Device mode: Normal
- IEC 61162-1 Transmit checksum: Not used
- Checksum: \$ char not included (IEC 61162-1 & EMRI)

On the right side of the dialog, there are two buttons: "OK" and "Cancel".

### Storing default parameters

After installing the equipment, store the default parameters of the radar as follows:

1. Connect service (for PC) keyboard.
2. Press Windows key.
3. Open Window Explorer (**Start>Programs>Windows Explorer**)
4. Open directory **C:\ants\_system\params**.

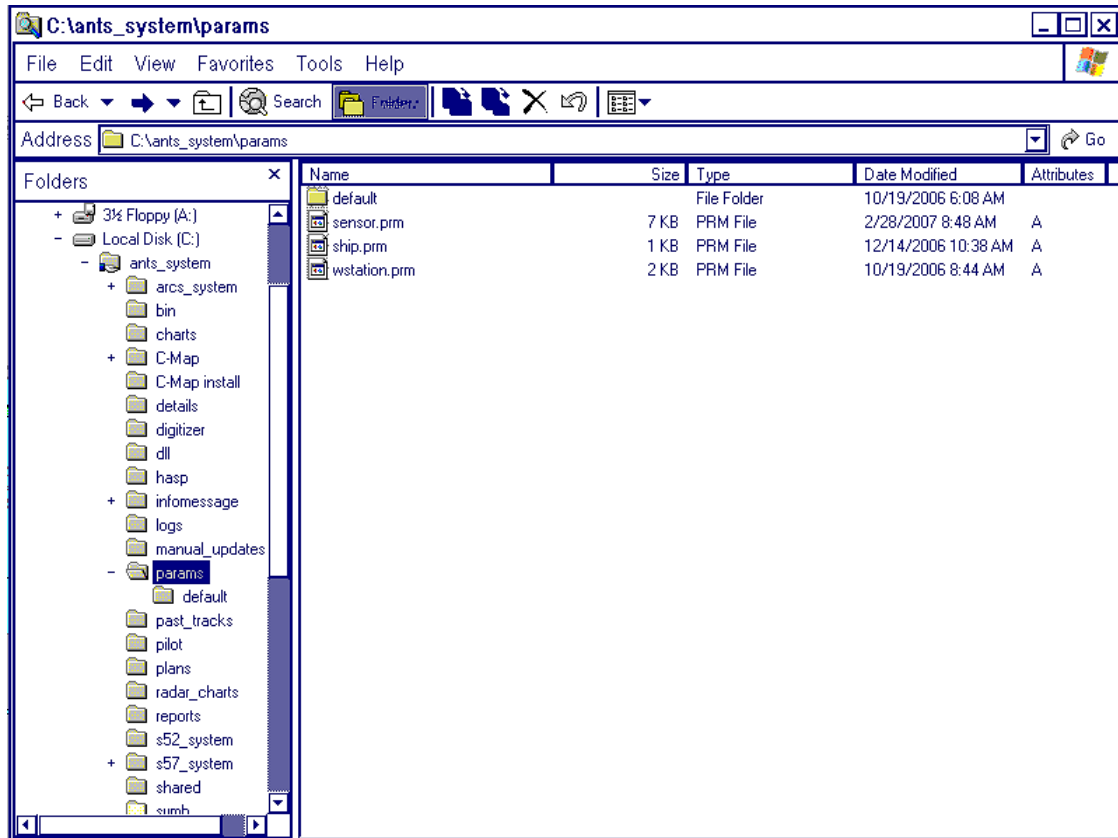

5. Select the files **sensor.prm**, **ship.prm** and select **Copy** from Edit file.
6. Select directory **C:\ants\_system\params\default** and select **Paste** from Edit menu.  
To copy them, confirm replacement of existing file, by pressing **OK**.
7. Go back to normal radar operation mode.

## 3.11 Adjustments for LAN Adapter EC-1010

### Before adjusting LAN adapter and updating program

The following tools are needed for programming LAN adapter:

- Ordinary serial line cross-cable to make connection from COM1 port to Connector J13 of LAN Adapter (9 pins female – 9 pins female).

You need to set the jumpers of the LAN adapter to enable connector J13 and programming mode.

To change J1 (CH 1) connector to J13 Connector for programming, set as below.

J17	GND
J14	TXP
J15	RXP

To enable manual startup and programming, set as below.

J16	INIT-GND
-----	----------

\* See page 3-46 for parts location.

### IP address agreement for LAN Adapter

Below is a table where you can find IP addresses for each device.

Device	First chart processor	Second chart processor
First LAN adapter	10.0.0.194	10.0.0.196
Second LAN adapter	10.0.0.195	10.0.0.197

## How to update programs for LAN adapter

Update of the program is required, proceed as follows.

1. Open Explorer and directory C:\LAN Adapter, and then double click 7188xw.exe.

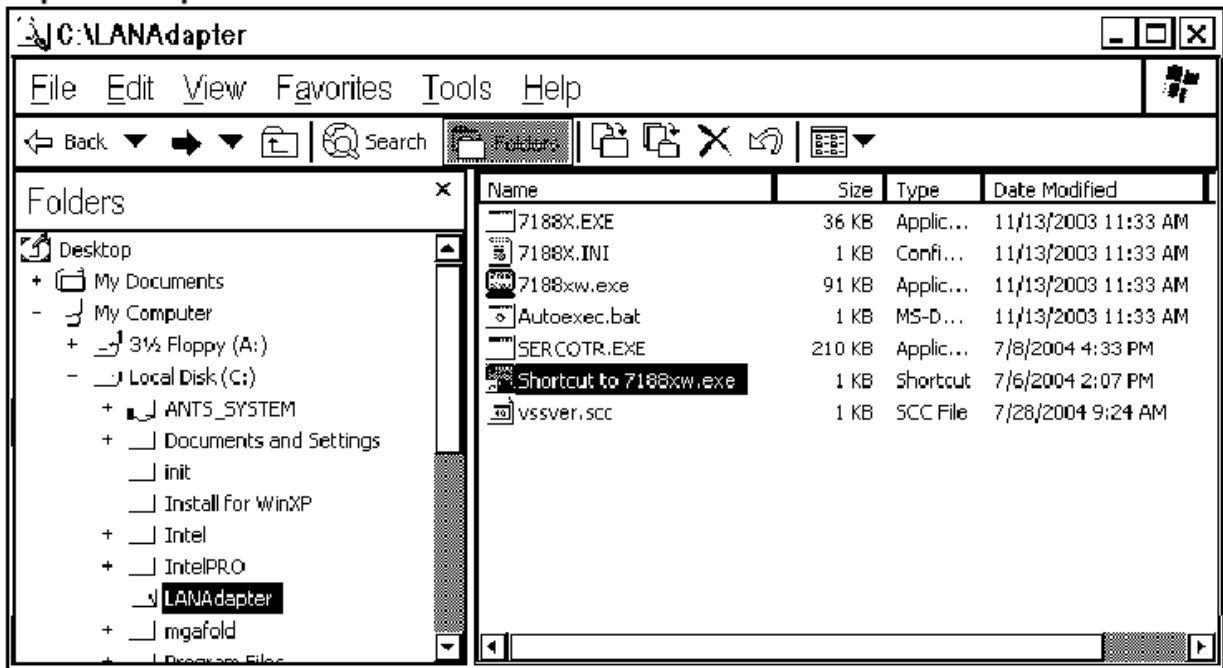

7188XW program will start in MS DOS window.

```

7188XW 1.14 [COM1:115200,N,8,1] DIR=C:\LANAdapter
7188x for WIN32 version 1.14 (03/08/2002)[By ICPDAS. Tim.]
Current set: Use COM1 115200,N,8,1
AutoRun:
Autodownload files: None
Current work directory="C:\LANAdapter"
original baudrate = 9600!
now baudrate = 115200!

i7188E>_
  
```

### 3. SETTING AND ADJUSTMENT

2. To remove old files from LAN adapter; type "del", and then press the Y key. Load autoexec.bat and sercotr.exe as shown below.

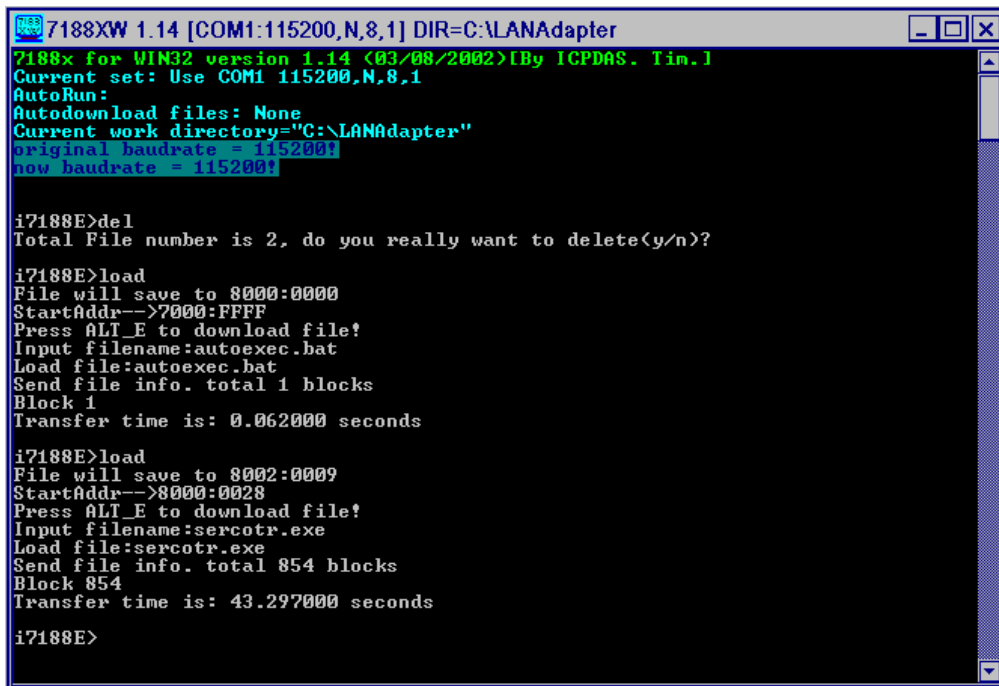

```
7188XW 1.14 [COM1:115200,N,8,1] DIR=C:\LANAdapter
7188x for WIN32 version 1.14 (03/08/2002) [By ICPDAS. Tim.]
Current set: Use COM1 115200,N,8,1
AutoRun:
Autodownload files: None
Current work directory="C:\LANAdapter"
original baudrate = 115200!
now baudrate = 115200!

i7188E>del
Total File number is 2, do you really want to delete(y/n)?

i7188E>load
File will save to 8000:0000
StartAddr-->7000:FFFF
Press ALT_E to download file!
Input filename:autoexec.bat
Load file:autoexec.bat
Send file info. total 1 blocks
Block 1
Transfer time is: 0.062000 seconds

i7188E>load
File will save to 8002:0009
StartAddr-->8000:0028
Press ALT_E to download file!
Input filename:sercotr.exe
Load file:sercotr.exe
Send file info. total 854 blocks
Block 854
Transfer time is: 43.297000 seconds

i7188E>
```

3. Type "DIR", and confirm that autoexec.bat and sercotr.exe are loaded as shown below.



```
7188XW 1.14 [COM1:115200,N,8,1] DIR=c:\LANAdapter
i7188E>DIR
Total File number is 0 Free space=458720 bytes
i7188E>LOAD Autoexec.bat
File will save to 8000:0000
StartAddr-->7000:FFFF
Press ALT_E to download file!
Input filename:Autoexec.bat
Load file:Autoexec.bat
Send file info. total 1 blocks
Block 1
Transfer time is: 0.063000 seconds

i7188E>LOAD SERCOTR.EXE
File will save to 8002:0009
StartAddr-->8000:0028
Press ALT_E to download file!
Input filename:SERCOTR.EXE
Load file:SERCOTR.EXE
Send file info. total 862 blocks
Block 862
Transfer time is: 43.594000 seconds

i7188E>DIR
0)Autoexec.bat 11/13/2003 10:33:00 9[00009]8002:0000-8002:0009
1)SERCOTR.EXE 06/26/2009 08:41:06 220546[35D82]8004:0009-B5DC:000B
Total File number is 2 Free space=238101 bytes
i7188E>
```

4. Type "sercotr", and confirm that the version number is updated. LAN Adapter xx.xxx is displayed before command prompt.

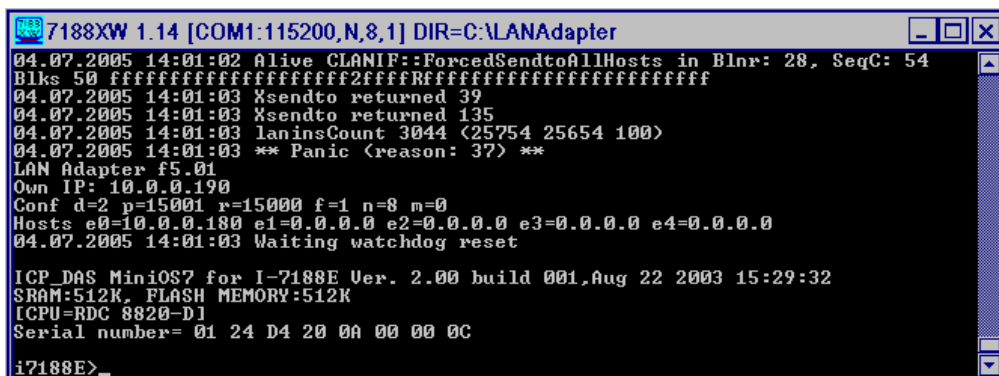

```
7188XW 1.14 [COM1:115200,N,8,1] DIR=C:\LANAdapter
04.07.2005 14:01:02 Alive GLANIF::ForcedSendtoAllHosts in Blnr: 28, SeqC: 54
Blks 50 ffffffff2ffffRffffffffffffffffffff
04.07.2005 14:01:03 %sendto returned 39
04.07.2005 14:01:03 %sendto returned 135
04.07.2005 14:01:03 laninsCount 3044 (25754 25654 100)
04.07.2005 14:01:03 ** Panic (reason: 37) **
LAN Adapter f5.01
Own IP: 10.0.0.190
Conf d=2 p=15001 r=15000 f=1 n=8 m=0
Hosts e0=10.0.0.180 e1=0.0.0.0 e2=0.0.0.0 e3=0.0.0.0 e4=0.0.0.0
04.07.2005 14:01:03 Waiting watchdog reset

ICP_DAS MiniOS7 for I-7188E Ver. 2.00 build 001,Aug 22 2003 15:29:32
SRAM:512K, FLASH MEMORY:512K
[CPU=RDC 8820-D]
Serial number= 01 24 D4 20 0A 00 00 0C

i7188E>
```



### Parameters for LAN adapter EC-1010

Set parameters for LAN adapter as follows.

Unit	Type command
First LAN adapter of chart processor	sercotr /d=2 /p=15001 /r=15000 /f=1 /n=8 /m=0 /e0=10.0.0.184 /e1=0.0.0.0
Second LAN adapter of chart processor	sercotr /d=3 /p=15001 /r=15000 /f=9 /n=8 /m=0 /e0=10.0.0.184 /e1=0.0.0.0

a) For example, type the command for First LAN adapter. (Note! IP address for first Chart Radar e0=10.0.0.184)

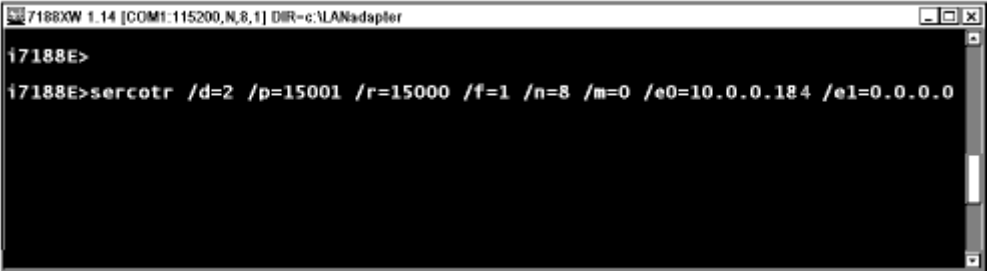

b) Then type the command: sercotr /e2=0.0.0.0 /e3=0.0.0.0 e4=0.0.0.0 (in common with First and Second)

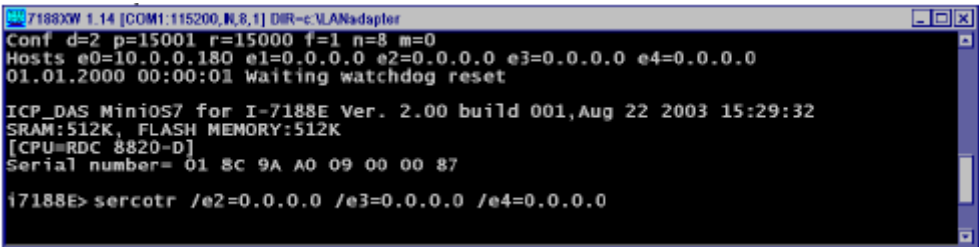

Parameter	Meaning	Setting
d	device number	2: First LAN adapter of chart processor 3: Second LAN adapter of chart processor
p	LAN adapter port	15001: mandatory port number
r	radar port	15000: mandatory port number
f	number of first serial port	1: first LAN adapter 9: second LAN adapter
n	number of serial channels	8: mandatory number of serial channels
m	operating mode	0: normal operation mode 1: debug mode
e0	IP address of first client	10.0.0.184/10.0.0.185
e1 - e4	IP address of another client	0.0.0.0

### 3. SETTING AND ADJUSTMENT

## How to check and change IP address of LAN adapter EC-1010

You can check and change the IP address of the LAN adapter as follows:

1. Open Explorer and then double-click 7188xw.exe.

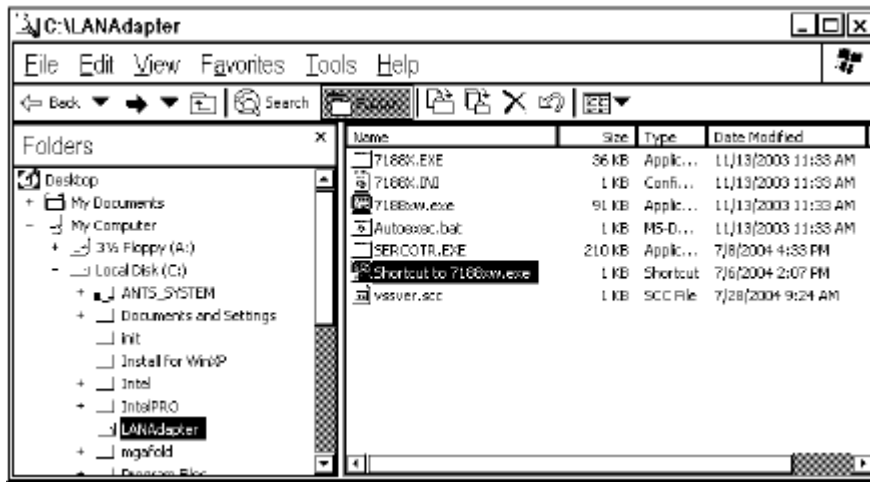

7188XW program starts in MS DOS window.

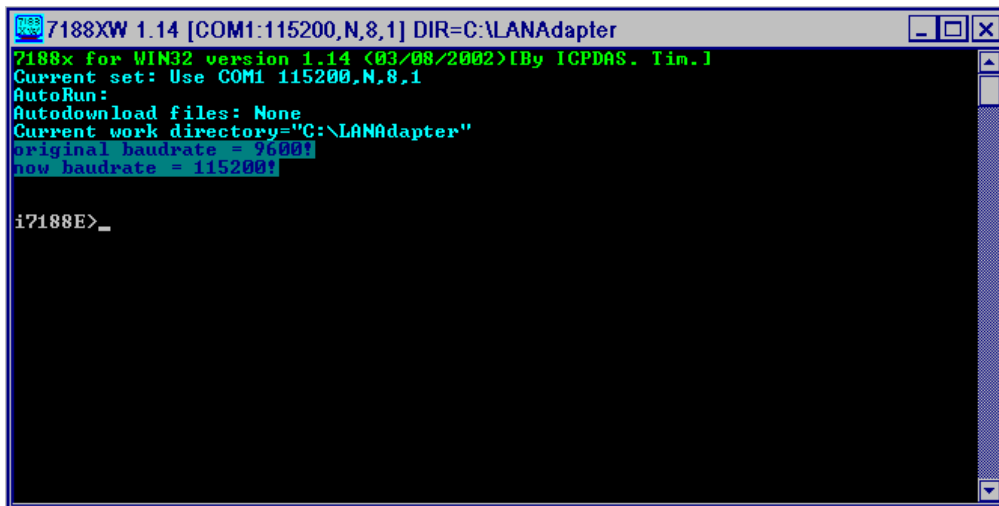

Type IP and then press the **ENTER** key. (Note! IP address for first chart Radar e0-10.0.0.184)

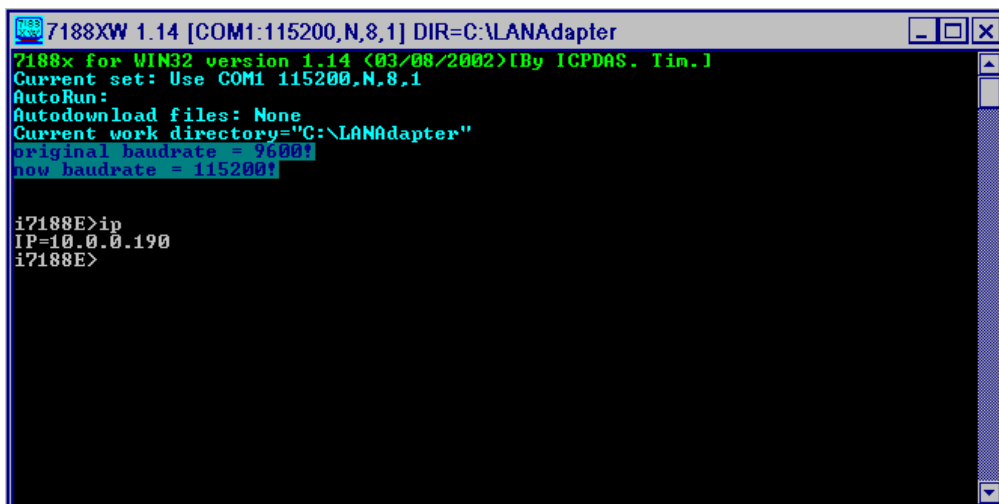

2. If you want to change IP address, type setip 10.0.0.194(example for First LAN Adapter).

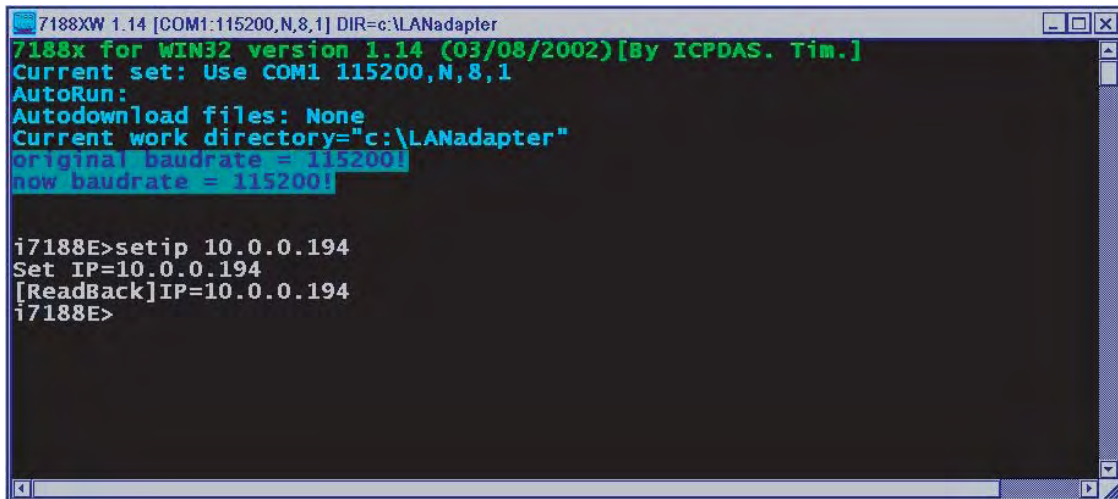

```
7188XW 1.14 [COM1:115200,N,8,1] DIR=c:\LANadapter
7188x for WIN32 version 1.14 (03/08/2002) [By ICPDAS. Tim.]
Current set: Use COM1 115200,N,8,1
AutoRun:
Autodownload files: None
Current work directory="c:\LANadapter"
original baudrate = 115200!
now baudrate = 115200!

i7188E>setip 10.0.0.194
Set IP=10.0.0.194
[ReadBack]IP=10.0.0.194
i7188E>
```

### 3.12 DIP Switches and Jumper Wires

#### LAN adapter EC-1010

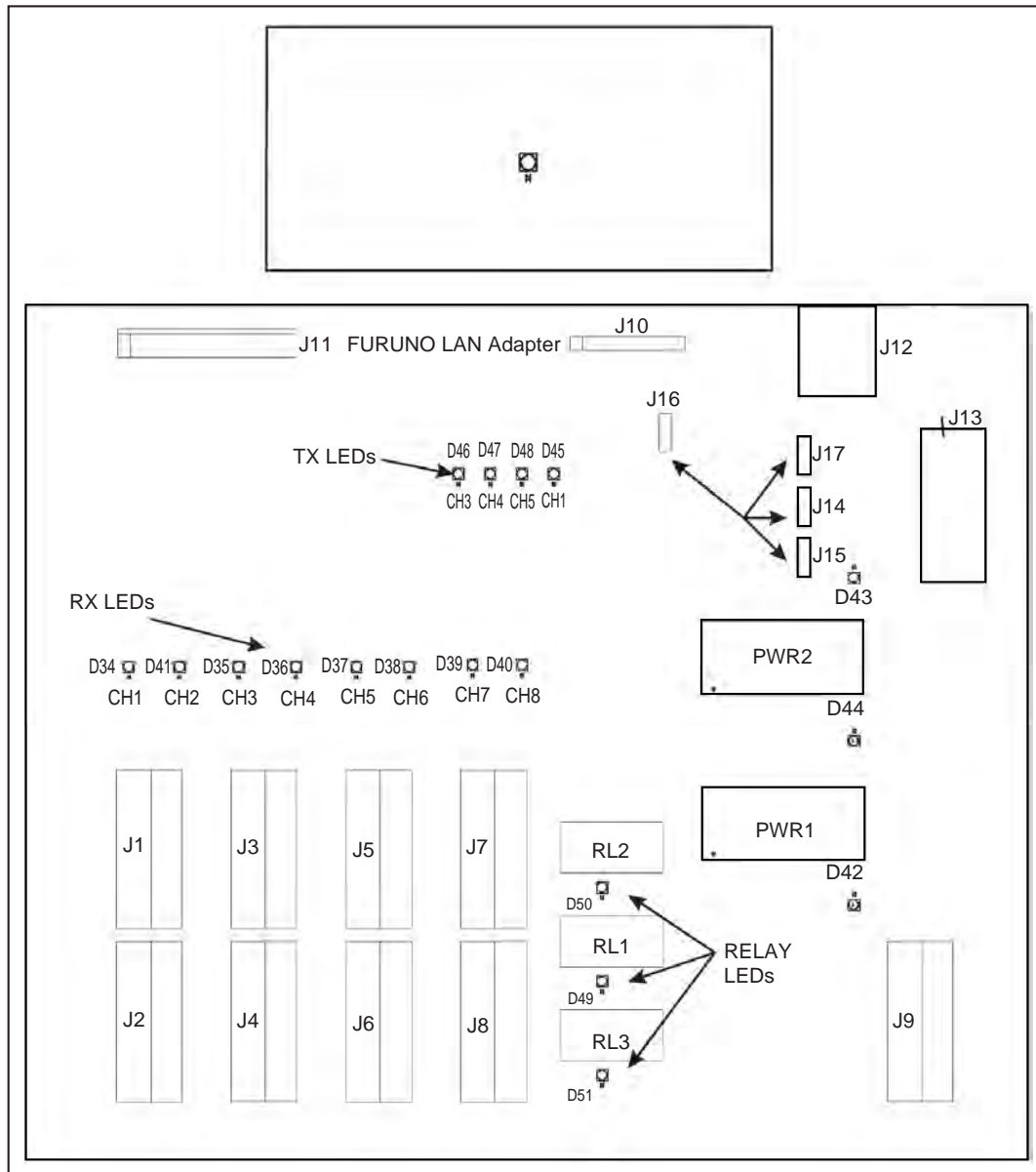

Jumper	Position	Function
J14	TXP	Programming
	TXD1	Normal operation (Default)
J15	RXP	Programming
	RXD1	Normal operation (Default)
J17	CTS1 H-CTS1	Normal operation (Default)
	GND	Programming
J16	INIT H-INIT	Normal operation (Default)
	GND-INIT	Programming

# 4. INSTALLING OPTIONAL EQUIPMENT

---

## 4.1 Gyro Converter GC-10

The Gyro Converter GC-10, incorporated inside the processor unit, converts analog gyrocompass reading into digital coded bearing data for display on the radar screen.

This section explains how to install the GC-10 (mainly consisting of the GYRO CONVERTER board) and set it up according to gyrocompass connected.

### Installing the GYRO CONVERTER board

Necessary Parts: GC-10-2 (Code number 000-080-440)

See packing list for details at the back of this manual.

1. Open the processor unit.

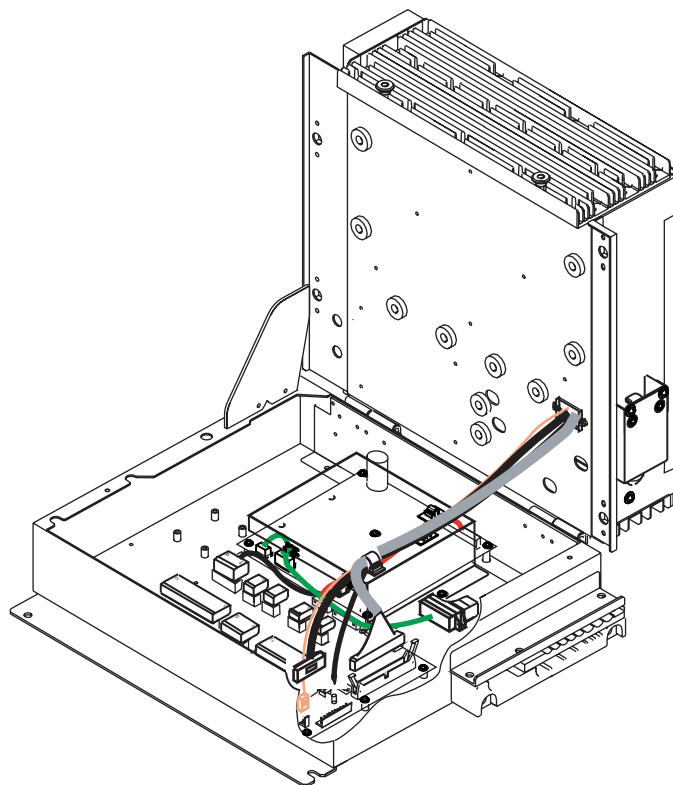

*Processor unit (Opened)*

#### 4. INSTALLING OPTIONAL EQUIPMENT

2. Fasten the GYRO CONVERTER board in the processor unit with five washer head screws and male connector 231-607/019-FUR (called J602) with two screws.

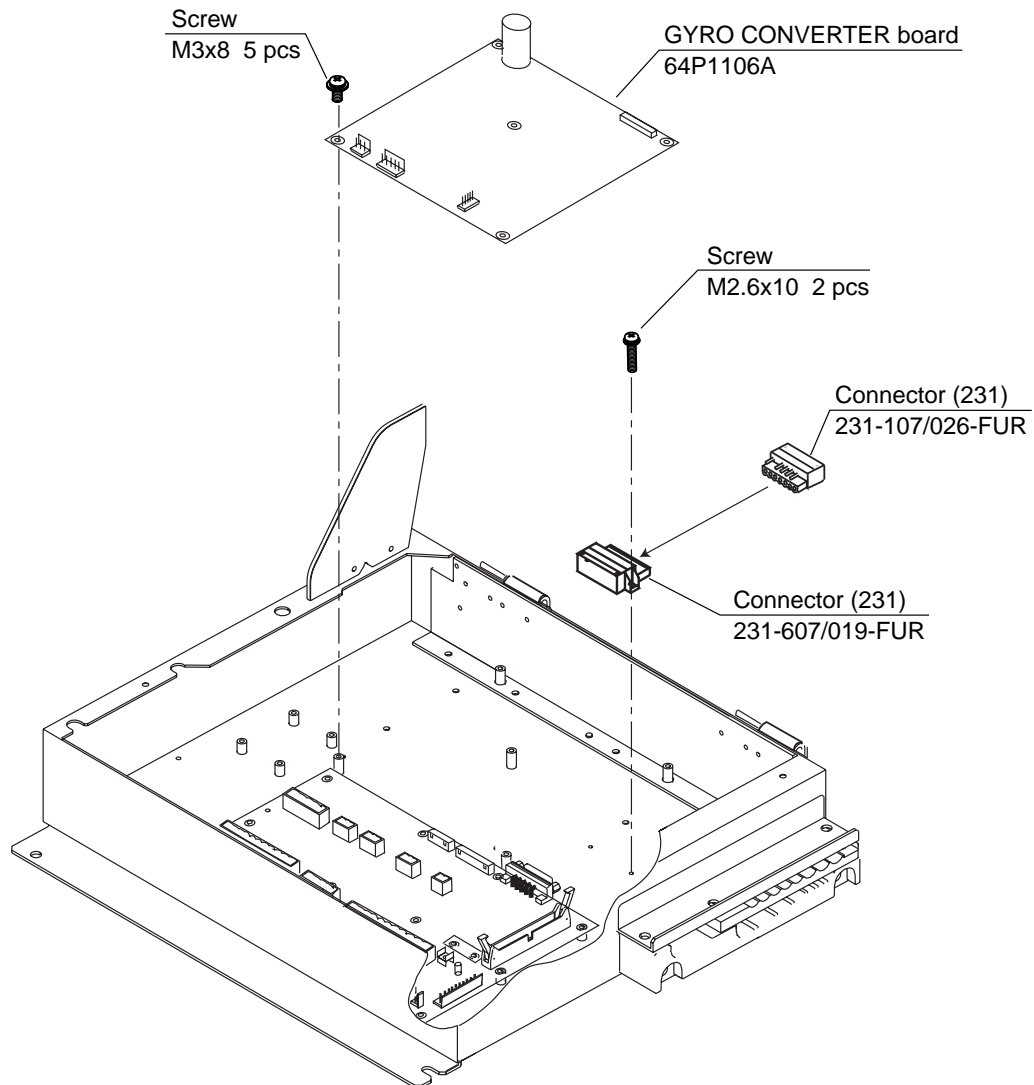

*Attaching GYRO CONVERTER board in the processor unit*

3. Connect the GYRO CONVERTER board and the 03P9342 board with connector assemblies 03-2088 and 03-2091.

4. Connect the GYRO CONVERTER board and J602 with two connector assemblies 03-2089 and 03-2090.

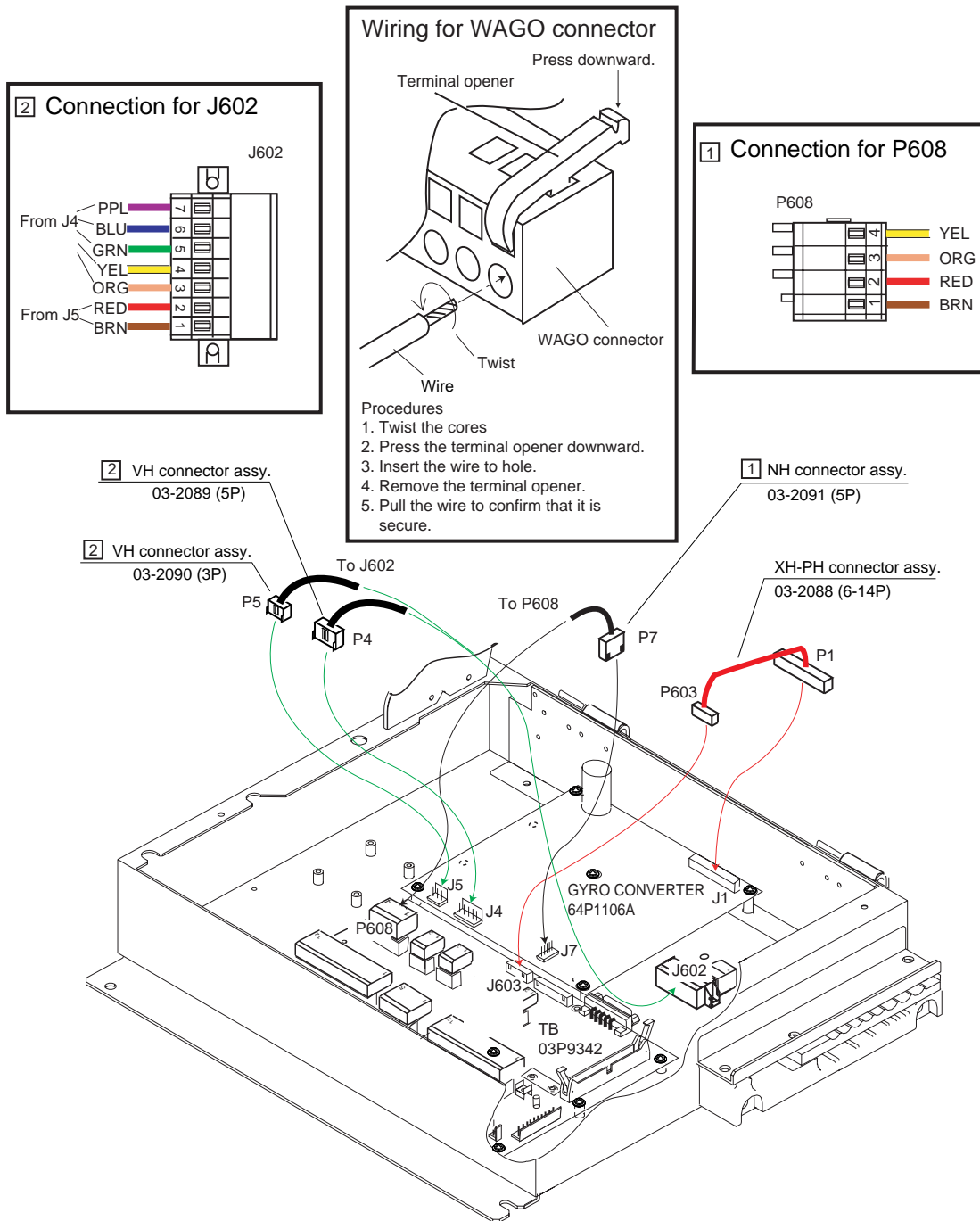

Connecting connector assemblies

#### 4. INSTALLING OPTIONAL EQUIPMENT

5. Confirm gyrocompass specifications and set up the DIP switches and jumper wires on the GYRO CONVERTER board according to gyrocompass connected:
  - Setting jumper wires and DIP switches by gyrocompass specifications: page 4-5
  - Setting jumper wires and DIP switches by maker and model of gyrocompass: page 4-7
  - Location of jumper wires and DIP switches: page 4-8
6. Pass gyrocompass cable through the cable clamp and connect it to connector J602 as shown in the figure on page 4-3.
7. Attach the clamps on the plastic cover and then attach the cover to the GYRO CONVERTER board as shown in the figure below. Insert cables to the clamp ED-1, respectively.

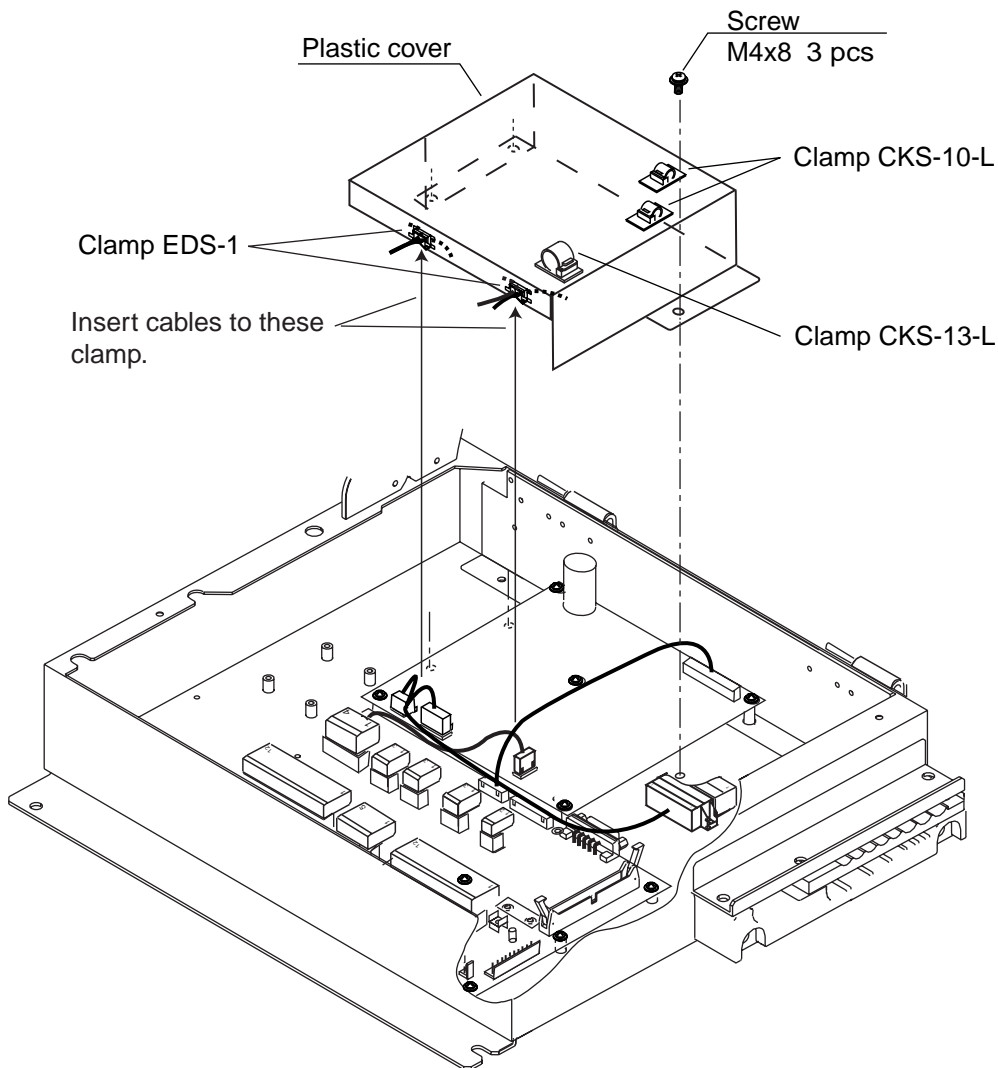

*Attaching plastic cover for GYRO CONVERTER board*

8. Close the processor unit.



## Connection of external power supply

An external power supply is necessary when the repeater signal is step-by-step type and the step voltage is below 20 V or output voltage is less than 5 W.

1. Cut jumper wire JP1 on the GYRO CONVERTER board when an external power supply is used.
2. Connect gyro cable and power cable as shown below.

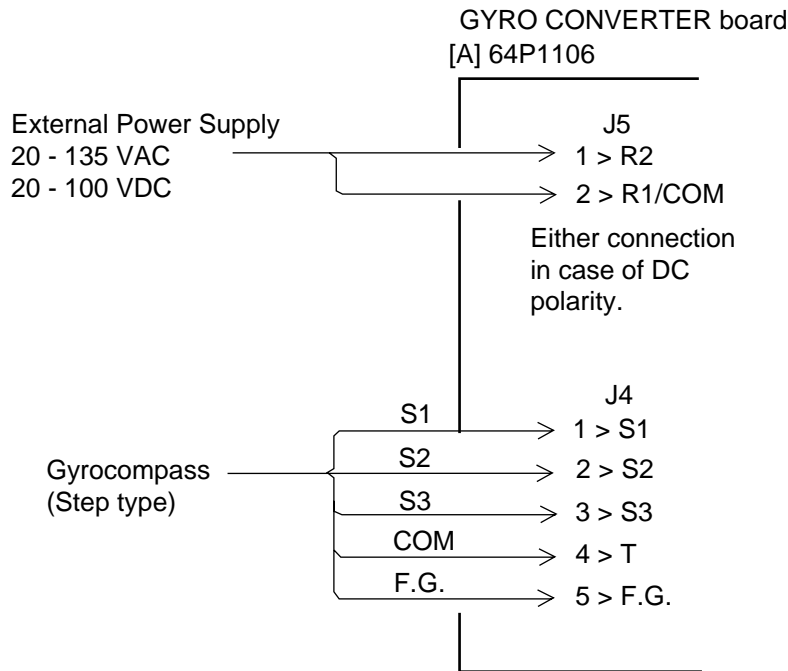

*Connection of external power supply to GYRO CONVERTER board*

## DIP switch, jumper wire settings

### Default setting

The gyro converter GC-10 is set at the factory for connection with the gyrocompass specifications below.

AC synchronous signal: 50/60 Hz  
 Rotor voltage: 60 V to 135 V AC  
 Stator voltage: 60 V to 135 V AC  
 Gear ratio: 360x  
 Supply voltage: 30 V to 135 V AC

If the specifications of the gyrocompass differ from those mentioned above, change jumper wire and DIP switch settings on the GYRO CONVERTER board. Settings may be changed according to gyrocompass specifications (see page 4-6) or maker and model of gyrocompass (see page 4-7). For the location of DIP switches and jumper wires, see page 4-8.

Note: If you change the setting with power supplied, set #8 of SW2 from OFF to ON, then OFF again.

#### 4. INSTALLING OPTIONAL EQUIPMENT

### Setting method 1: DIP switch settings and gyrocompass specifications

#### 1) Gyrocompass type

Gyrocompass type	SW 1-4	SW 1-5	SW 1-6	JP1
AC synchronous	OFF	OFF	OFF	#1, #2, #3
DC synchronous	OFF	OFF	OFF	#2, #3, #4
DC step	ON	OFF	OFF	#4, #5, #6
Full-wave pulsating current	OFF	ON	OFF	#4, #5, #6
Half-wave pulsating current	ON	ON	OFF	#4, #5, #6

#### 2) Frequency

Frequency	SW 1-7	SW 1-8	Remarks
50/60 Hz	OFF	OFF	AC synchronous pulsating current
400 Hz	ON	OFF	AC synchronous pulsating current
500 Hz	OFF	ON	AC synchronous pulsating current
DC	ON	ON	DC synchronous DC step

#### 3) Rotor Voltage (between R1 & R2)

Rotor Voltage	SW 2-1	JP3
20 to 45 VAC	ON	#2
30 to 70 VAC	OFF	#2
40 to 90 VAC	ON	#1
60 to 135 VAC	OFF	#1

#### 4) Stator Voltage (between S1 & S2)

Stator Voltage	SW 2-2	SW 2-3	JP2
20 to 45 VAC, or 20 to 60 VDC	ON	OFF	#2
30 to 70 VAC, or 40 to 100 VDC	OFF	OFF	#2
40 to 90 VAC	ON	OFF	#1
60 to 135 VAC	OFF	OFF	#1

#### 5) Ratio

Ratio	SW 1-1	SW 1-2	SW 1-3
360X	OFF	OFF	OFF
180X	ON	OFF	OFF
90X	OFF	ON	OFF
36X	ON	ON	OFF

#### 6) Supply Voltage

Stator Voltage	JP4	JP5
20 to 45 VAC, or 20 to 60 VDC	#2	#2
30 to 70 VAC, or 40 to 100 VDC	#1	#1

#### 7) AD-10 format data Tx interval

Select data transmitting interval for ports 1 to 6 with jumper wires JP6 and JP7: #25 for 25 ms, #200 for 200 ms.

**Note:** The Tx interval is available in 25 msec or 200 msec. Use 25 msec for radar.

#### 8) NMEA-0183 Tx interval and Output sentence

Tx interval	SW 2-5	SW 2-6	Output sentence
1 s	OFF	OFF	HDT+VHW
200 ms	ON	OFF	HDT
100 ms	OFF	ON	HDT
25 ms	ON	ON	HDT

#### 9) NMEA-0183 Version no.

Version no.	SW3-1
1.5	OFF
2.0	ON

#### 10) NMEA-0183 Baud rate

Baud rate	SW3-2
4860bps	OFF
38400bps	ON

#### 11) Power fail detection

Talker	SW3-3
Disable	OFF
Enable	ON

(Use OFF for radar.)

#### 12) Stator signal breaking detection

Detection	SW2-7
Execute	OFF
No execute	ON

SW2-4: factory use only  
SW3-4: not used

**Setting method 2: by maker and model of gyrocompass**

Maker	Models	Specification	SW 1-1	SW 1-2	SW 1-3	SW 1-4	SW 1-5	SW 1-6	SW 1-7	SW 1-8	SW 2-1	SW 2-2	SW 2-3	JP1	JP2	JP3	JP4	JP5	
Anschutz	Standard 2,3	AC synchronous 50/60Hz Rotor voltage: 50/60V Stator voltage: 22V 360x	OFF	OFF	OFF	OFF	OFF	OFF	OFF	OFF	OFF	ON	OFF	#1, #2,#3	#2	#2	#1	#	
	Standard 4,6	AC synchronous 50/60Hz Rotor voltage: 50/60V Stator voltage: 90V 360x	OFF	OFF	OFF	OFF	OFF	OFF	OFF	OFF	OFF	OFF	OFF	#1, #2,#3	#2	#1	#1	#	
	Standard 20	DC step 35V 180x COM(-) ,3-wire(+)	ON	OFF	OFF	ON	OFF	OFF	ON	ON	-	ON	OFF	#4, #5,#6	#2	-	#2	#	
Yokogawa Navtec (Plath type)	C-1/1A/2/3 A-55, B-55	AC synchronous 50/60Hz Rotor voltage: 50/60V Stator voltage: 22V 360x	OFF	OFF	OFF	OFF	OFF	OFF	OFF	OFF	OFF	ON	OFF	#1, #2,#3	#2	#2	#1	#	
	CMZ-700	DC step 24V 180x COM(+), 3-wire(-)	ON	OFF	OFF	ON	OFF	OFF	ON	ON	-	ON	OFF	Remo- ve	#2	-	*	*	
	CMZ-250X/ 300X/500	DC synchronous 360x	OFF	OFF	OFF	OFF	OFF	OFF	ON	ON	-	ON	OFF	Remo- ve	#2	-	*	*	
		DC step 35V 180x COM(+),3-wire(-)	ON	OFF	OFF	ON	OFF	OFF	ON	ON	-	ON	OFF	#4, #5,#6	#2	-	#2	#2	
	CMZ-100/200/ 300 C-1Jr,D-1Z/1/3 IPS-2/3	AC synchronous 50/60Hz Rotor voltage: 100V Stator voltage: 90V 360x	OFF	OFF	OFF	OFF	OFF	OFF	OFF	OFF	OFF	OFF	OFF	OFF	#1, #2,#3	#1	#1	#1	#1
CMZ-50 See note below.	step 35V 180x COM(+),3-wire(-)	ON	OFF	OFF	ON	OFF	OFF	ON	ON	-	ON	OFF	Remo- ve	#2	-	*	*		
Plath	NAVGAT IIIII	AC synchronous 50/60Hz Rotor voltage: 50/60V Stator voltage: 68V 360x	OFF	OFF	OFF	OFF	OFF	OFF	OFF	OFF	OFF	OFF	OFF	#1, #2,#3	#2	#2	#1	#1	
Tokimec (Sperry type)	ES-1/2/11 GLT-101/102/ 103/106K/107	AC synchronous 50/60Hz Rotor voltage: 100/110V Stator voltage: 90V 36x	ON	ON	OFF	OFF	OFF	OFF	OFF	OFF	OFF	OFF	OFF	#1, #2,#3	#1	#1	#1	#1	
	ES-11A/110 TG-200 PR222R/2000 PR237L/H GM 21	AC synchronous 50/60Hz Rotor voltage: 100/110V Stator voltage: 22V 90x	OFF	ON	OFF	OFF	OFF	OFF	OFF	OFF	OFF	OFF	OFF	OFF	#1, #2,#3	#1	#1	#1	#1
	MK-14 MOD-1/2/T NK-EN,NK-EI	DC step 70V 180x COM(-), 3-wire(+)	ON	OFF	OFF	ON	OFF	OFF	ON	ON	-	OFF	OFF	#4, #5,#6	#2	-	#1	#1	
	SR-130/140	DC step 70V 180x 5-wire, open collector	ON	OFF	OFF	ON	OFF	OFF	OFF	OFF	-	OFF	OFF	#4, #5,#6	#2	-	#1	#1	
	TG-100/5000 PR-357/130/ 140, ES-17 GLT-201/202 /203	DC step 70V 180x COM(+), 3-wire(-)	ON	OFF	OFF	ON	OFF	OFF	ON	ON	-	OFF	OFF	#4, #5,#6	#2	-	#1	#1	
	TG-6000	DC step 24V 180x	ON	OFF	OFF	ON	OFF	OFF	ON	ON	-	ON	OFF	#4, #5,#6	#2	-	#2	#2	
	GM-11	AC synchronous 50/60Hz Rotor voltage: 100V Stator voltage: 90V 90x	OFF	ON	OFF	OFF	OFF	OFF	OFF	OFF	OFF	OFF	OFF	OFF	#1, #2,#3	#1	#1	#1	#1
	SR-120,ES-16 MK-10/20/30	DC step 35V 180x	ON	OFF	OFF	ON	OFF	OFF	ON	ON	-	ON	OFF	#4, #5,#6	#2	-	#2	#2	
Kawasaki	GX-81	AC synchronous 50/60Hz Rotor voltage: 100/110V Stator voltage: 90V 90x	OFF	ON	OFF	OFF	OFF	OFF	OFF	OFF	OFF	OFF	OFF	#1, #2,#3	#1	#1	#1	#1	
Armabrown	MK-10,MKL-1 SERIES1351, MOD-4	DC step 50V 180x COM(+), 3-wire(-)	ON	OFF	OFF	ON	OFF	OFF	ON	ON	-	OFF	OFF	#4, #5,#6	#2	-	#1	#1	
Robertson	SKR-80	DC step 35V 180x COM(-), 3-wire(+)	ON	OFF	OFF	ON	OFF	OFF	ON	ON	-	ON	OFF	#4, #5,#6	#2	-	#2	#2	

\*: Set JP4 and JP5 according to the voltage of the external power supply.

**Note:** If CMZ-50 has 35VDC, set JP1 to #4, #5, #6.

**Location of DIP switches, jumper wires on the GYRO CONVERTER board**

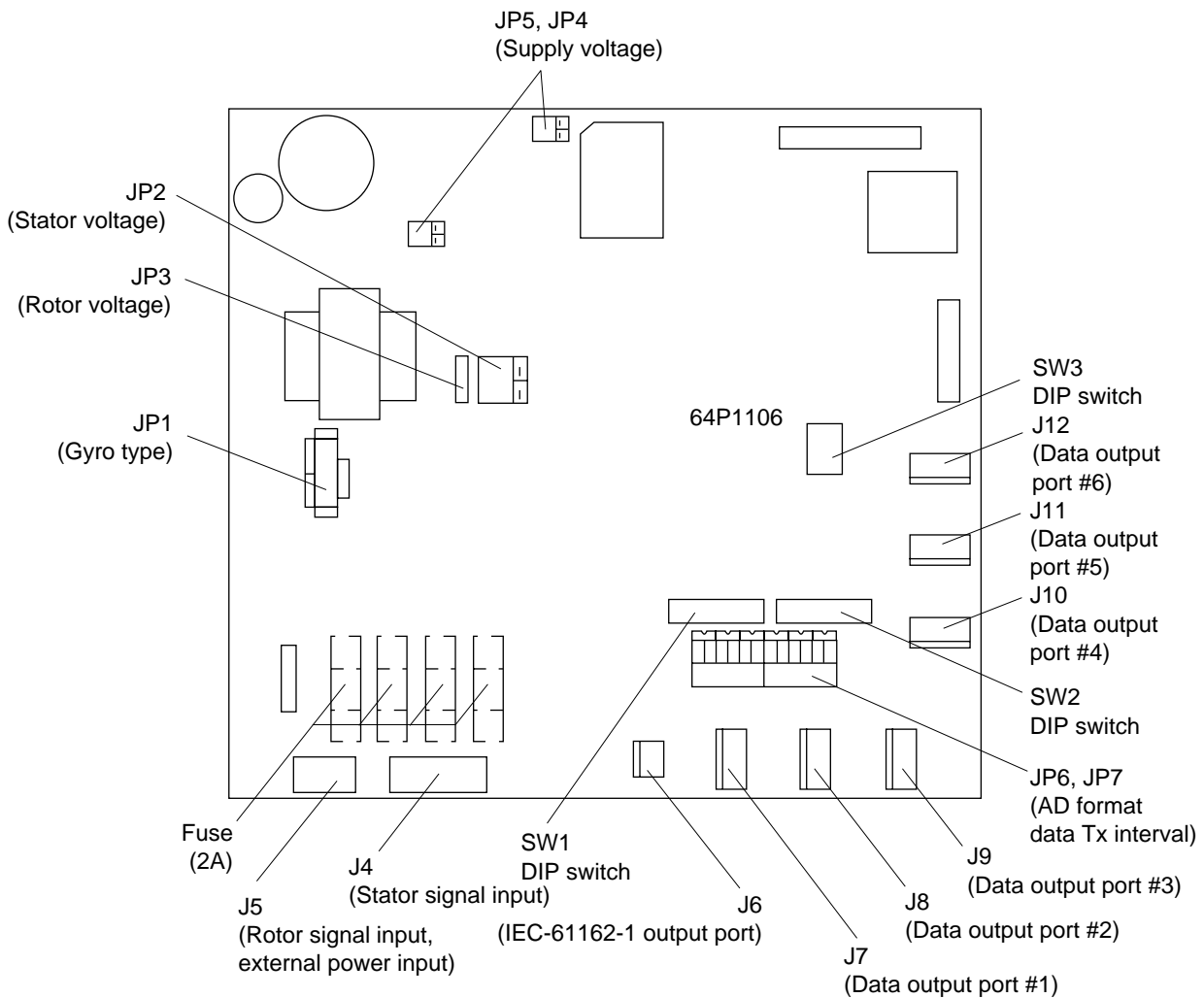

*GYRO CONVERTER board*

**Setting the heading readout on the radar display**

Confirm that the gyrocompass is giving a reliable readout. Then, set the heading readout on the radar display with the gyrocompass readout as follows:

1. Roll the trackball to place the arrow in the HDG box at the top right corner of the screen.
2. Push the right button on the trackball module to open the HDG menu.

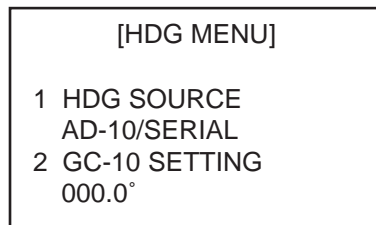

*HDG menu*

3. Press the [1] key to choose the HDG SOURCE and choose AD-10.
4. Press the [2] key to choose the GC-10 SETTING option.
5. Roll the wheel to set gyrocompass reading.
6. Press the [MENU] key to close the menu.

## 4.2 Junction Box

If the length of the antenna cable is more than 100 m, the optional junction boxes are required. These boxes should be mounted at the location protected because its waterproofing is IPX3.

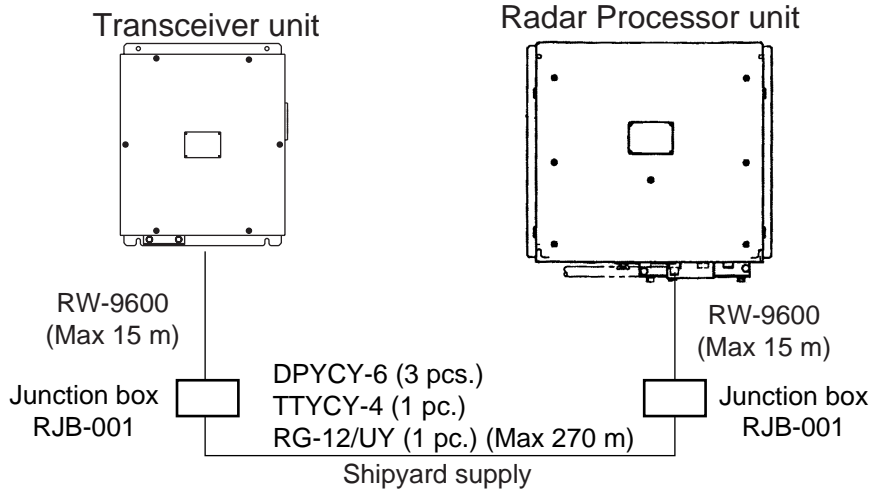

### Mounting

Fasten the junction boxes to the mounting location with four sets of M8 bolt and nut.

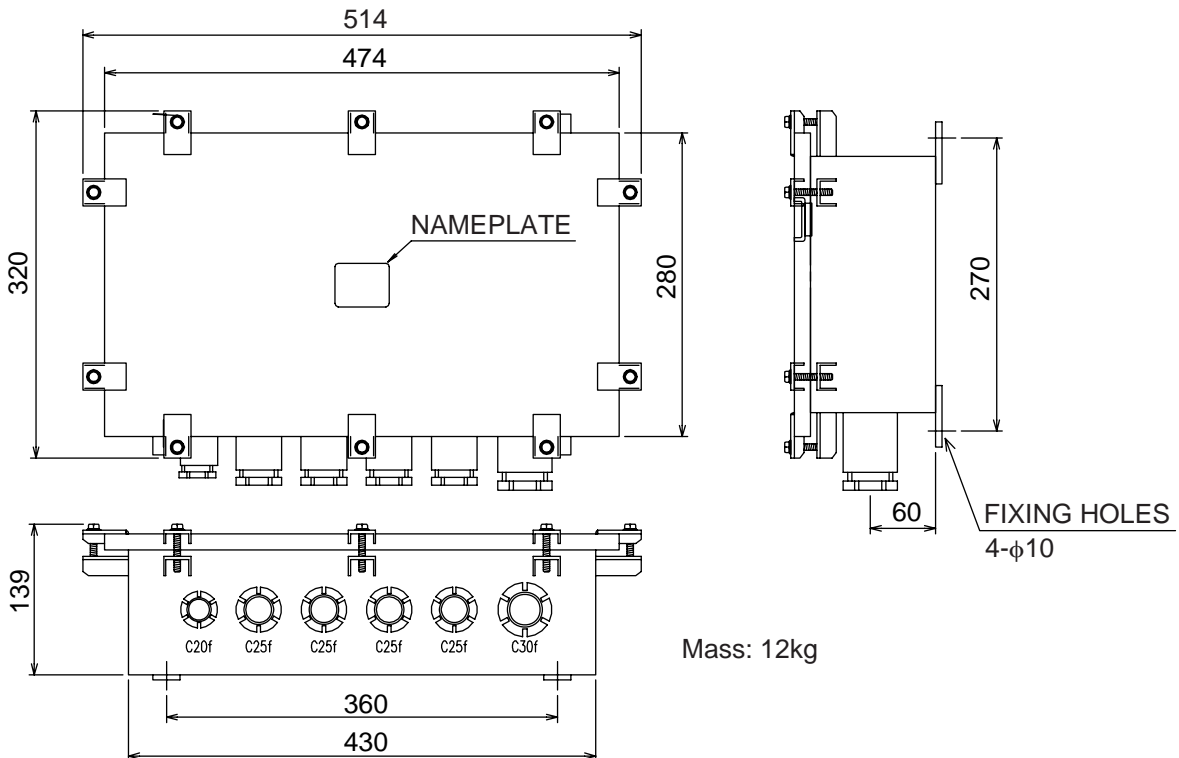

## 4. INSTALLING OPTIONAL EQUIPMENT

### Cable fabrication

#### RW-9600

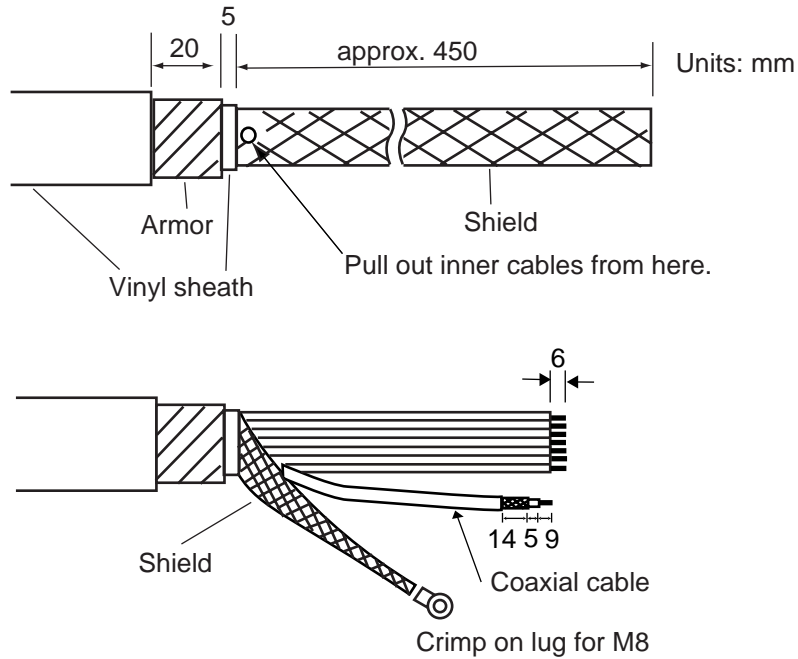

#### DPYC-6 and TTYC-4

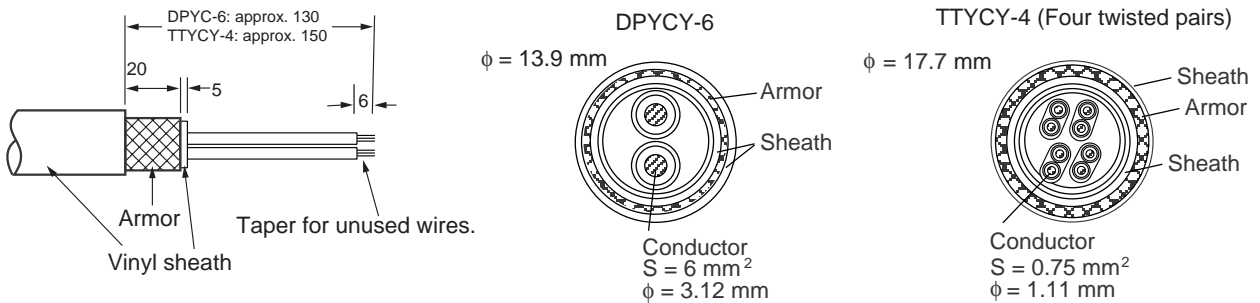

#### RG-12/UY

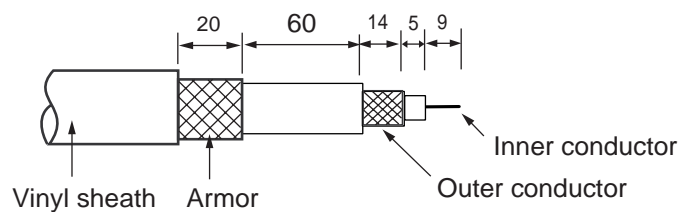

### Connection

Insert each cable to the cable gland as follows.

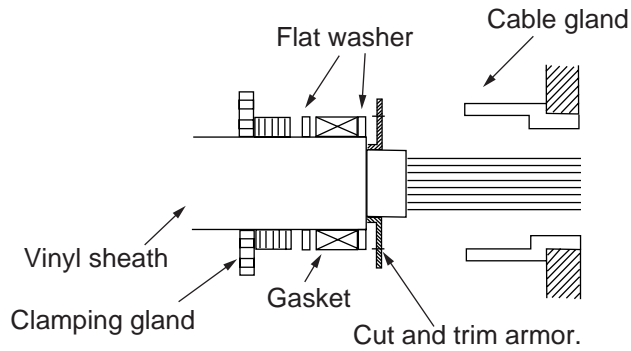

Connect each cable cores to the terminal board, referring to the interconnection diagram on next page.

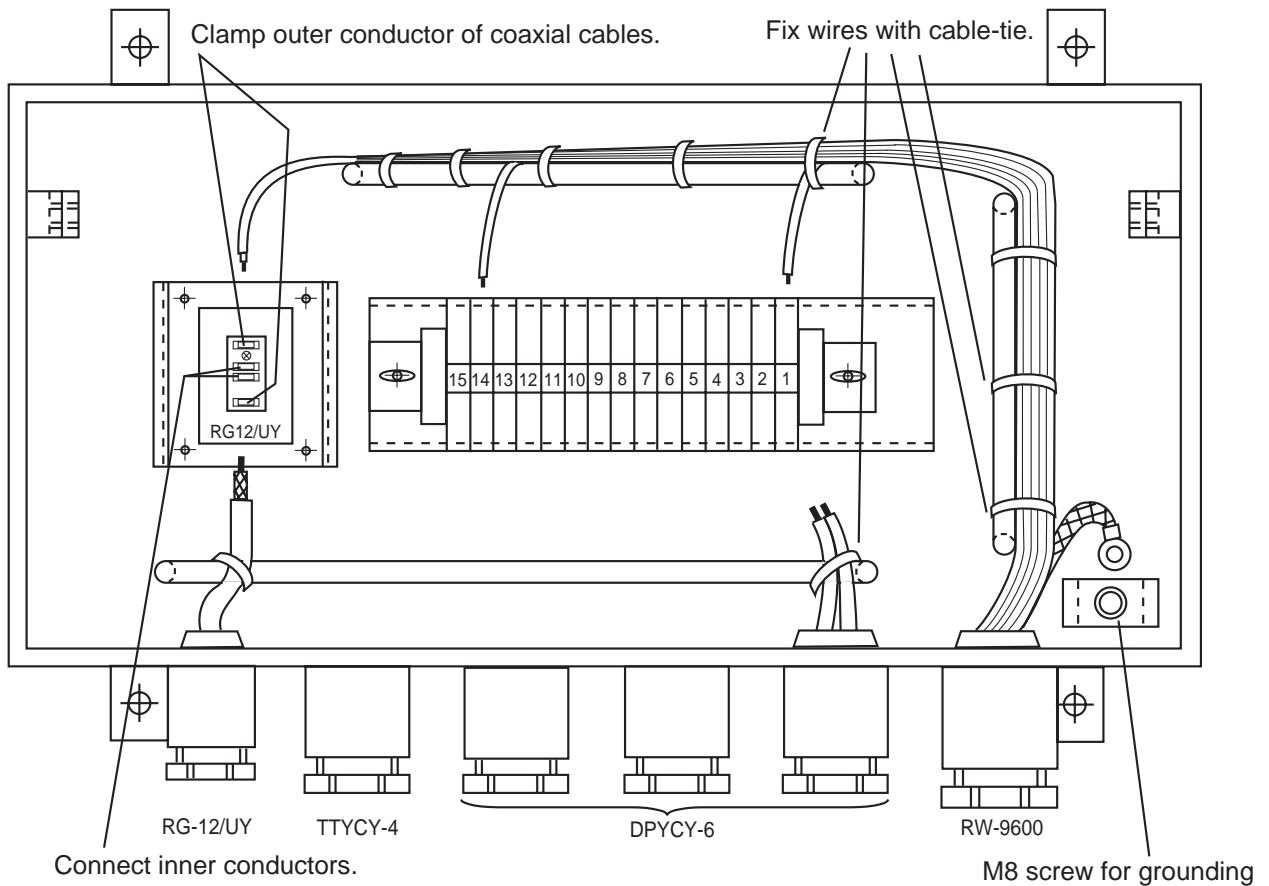

## 4. INSTALLING OPTIONAL EQUIPMENT

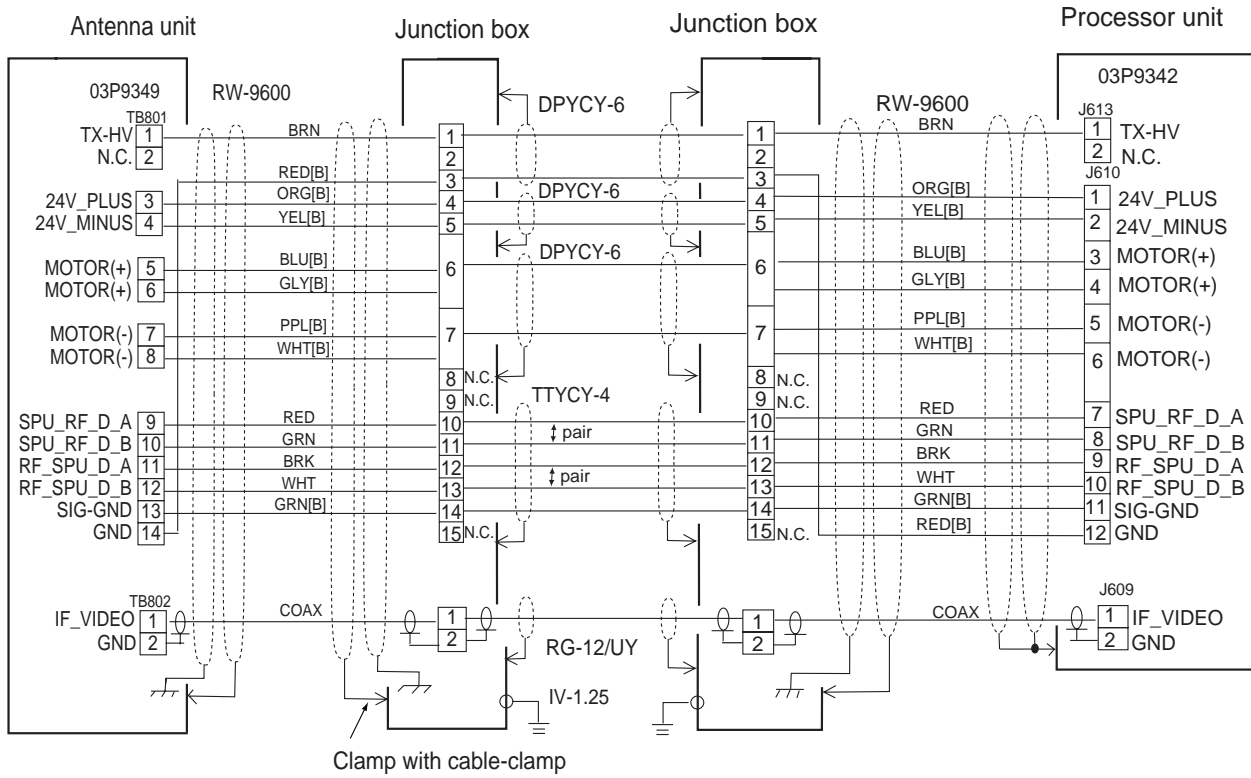



### 4.3 B Adapter

#### Cables fabrication for the cables connected to the B adapter

Use the following JIS (Japanese Industrial Standards) cables or equivalent. When using the TTYCS-4 cable, connect the appropriate cable to it to pass the cable entrance of the adapter.

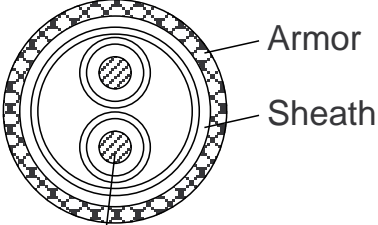
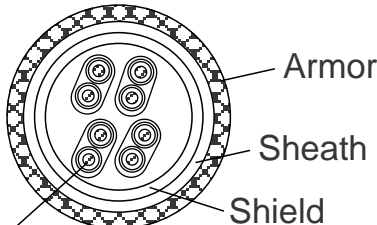
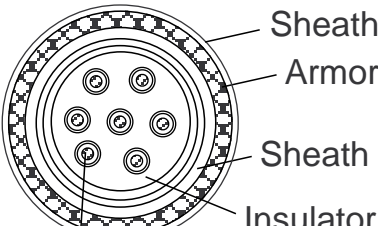
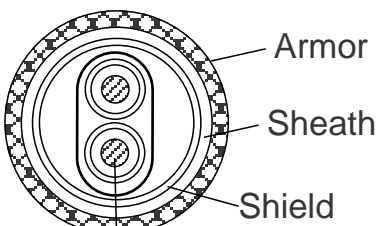
<p><math>\phi = 11.7 \text{ mm}</math></p>  <p>Armor Sheath Conductor <math>S = 1.5 \text{ mm}^2</math> <math>\phi = 1.56 \text{ mm}</math></p>	<p><math>\phi = 16.3 \text{ mm}</math></p>  <p>Armor Sheath Shield Conductor <math>S = 0.75 \text{ mm}^2</math> <math>\phi = 1.11 \text{ mm}</math></p>
<p>DPYC-1.5</p>	<p>TTYCS-4 (Four twisted pairs)</p>
<p><math>\phi = 13.2 \text{ mm}</math></p>  <p>Sheath Armor Sheath Insulator Conductor <math>S = 1 \text{ mm}^2</math> <math>\phi = 1.29 \text{ mm}</math></p>	<p><math>\phi = 10.1 \text{ mm}</math></p>  <p>Armor Sheath Shield Conductor <math>S = 0.75 \text{ mm}^2</math> <math>\phi = 1.11 \text{ mm}</math></p>
<p>MPYC-7</p>	<p>TTYCS-1 (Twisted pair cable)</p>

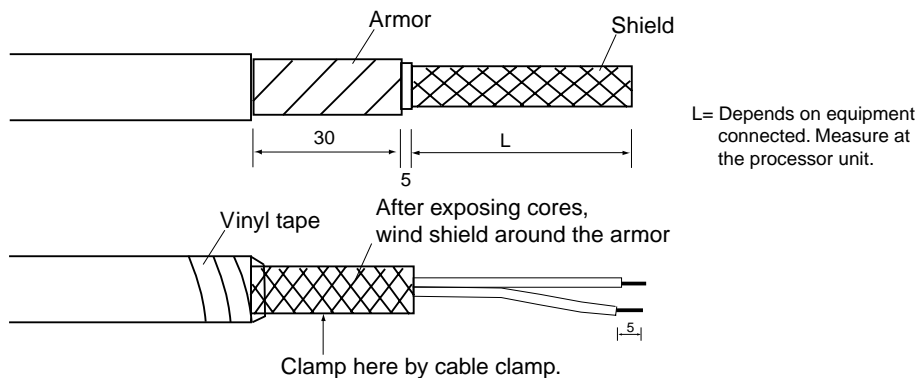

# 4. INSTALLING OPTIONAL EQUIPMENT

No.1 LAN adapter CH4  
or No.2 LAN adapter CH13

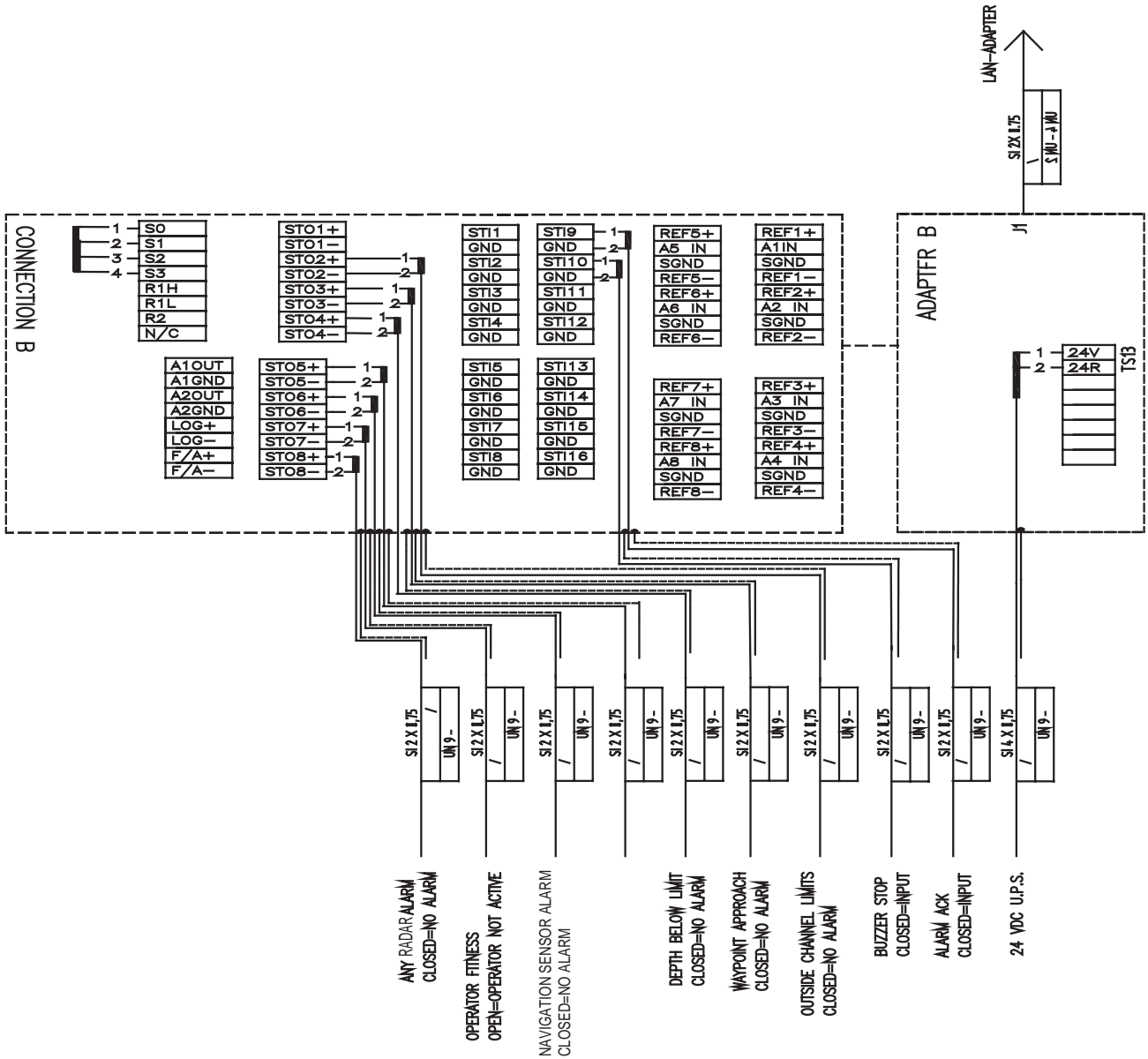

B Adapter (1)

# 4. INSTALLING OPTIONAL EQUIPMENT

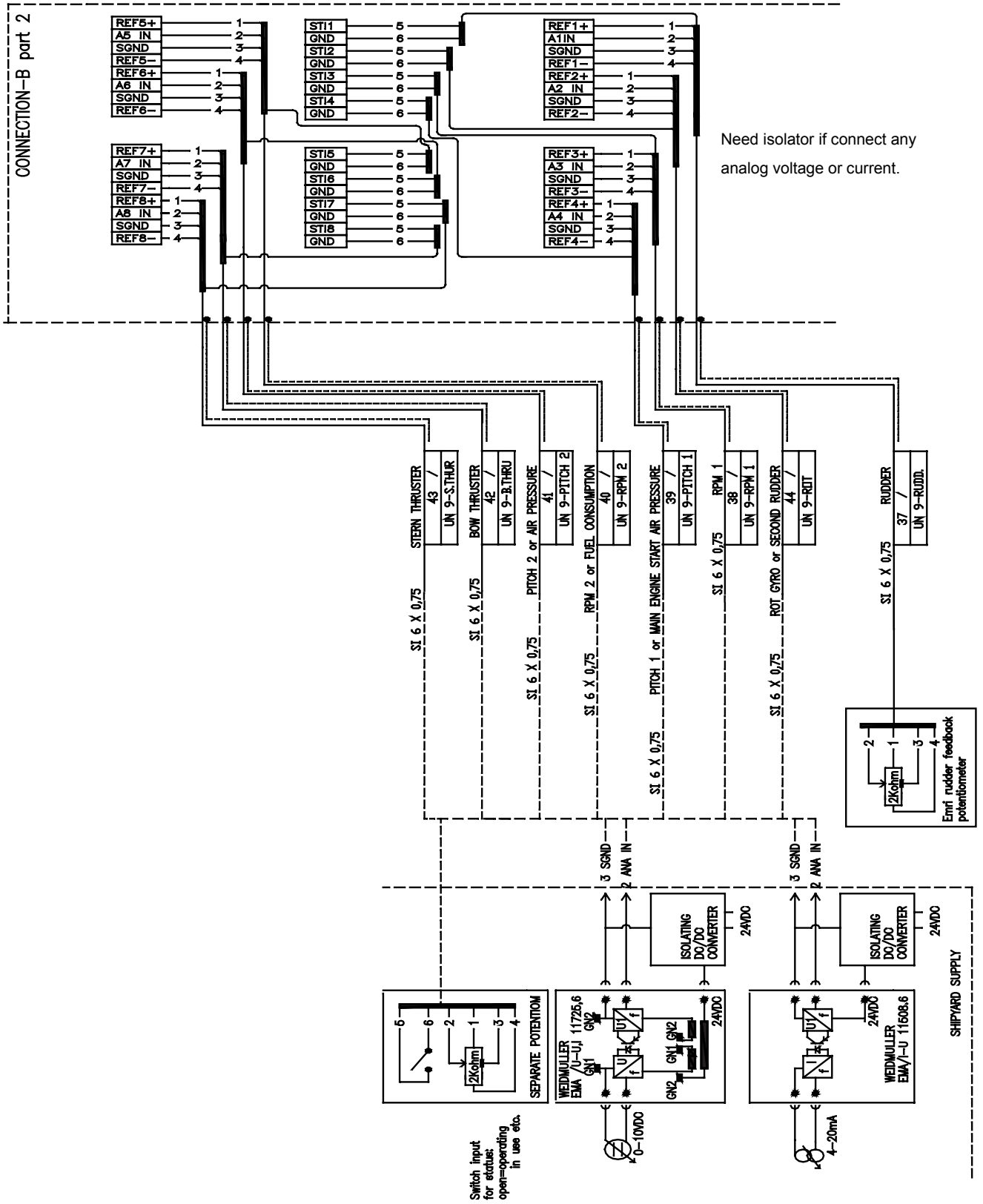

4. INSTALLING OPTIONAL EQUIPMENT

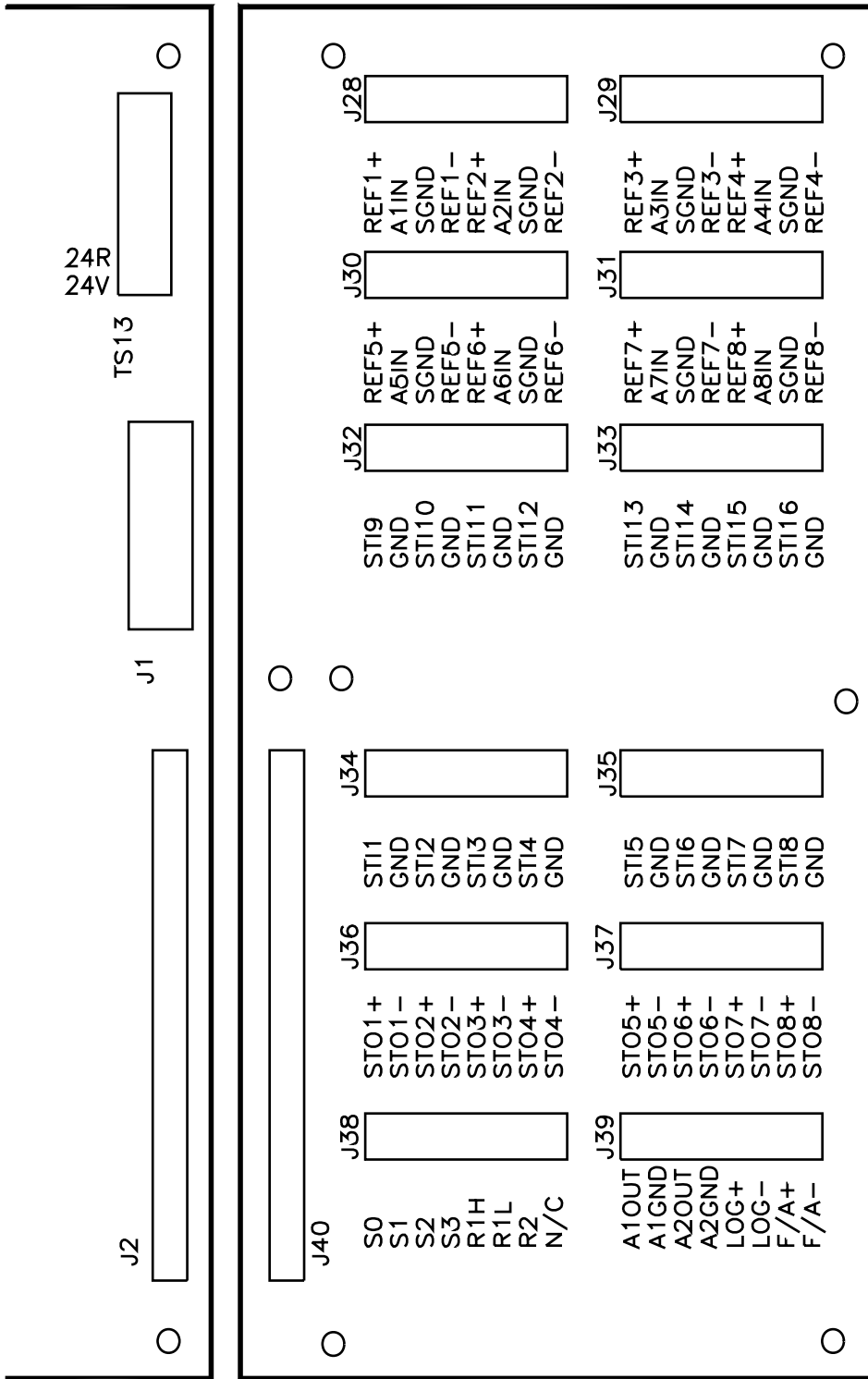

Connectors on B-Adapter

ALL CONNECTIONS ARE SCREW TERMINALS  
 0,14 - 1,0mm<sup>2</sup> AWG 28-16

## Interface

### Status output channels in general

Channel	State
1	RESERVED FOR FUTURE USE
2	ROUTE MONITOR: OUTSIDE CHANNEL LIMITS
3	ROUTE MONITOR: WAYPOINT APPROACH
4	ECHO: DEPTH BELOW LIMIT
5	NOT USED
6	NAVIGATION SENSOR ALARM
7	OPERATOR FITNESS
8	ANY radar ALARM

### Analog interface

**Note:** Analog interface is not used in this system.

### Analog channels in general

An example for analog channel (here, channel 1)

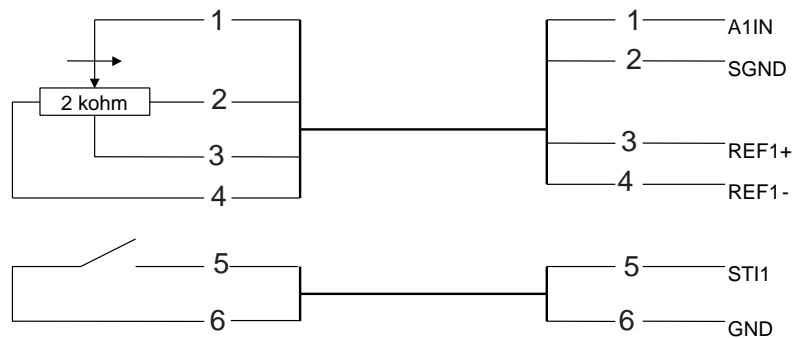

A1IN	input terminals for analog signal
SGND	
REF1+	reference output terminals
REF1-	
STI1	input terminals for status (open = operating, in use, etc.)
GND	

### Status input channels assignment

Channel	State
9	ALARM ACK.
10	BUZZER STOP

#### 4. INSTALLING OPTIONAL EQUIPMENT

This page is intentionally blank.

# 5. INPUT/OUTPUT DATA

## 5.1 Radar Processor Unit

Input and output data are shown in the table below.

### Input

Data	Specifications	Contents	Remarks
Heading signal	synchro or step	GC-10 required	AD-10 and IEC 61162 are switched by menu setting.
	AD-10 format	External AD-100	
	IEC 61162-2*		
Alarm ACK input	Contact closure		Input from alarm system

\*: Data input cycle should be more than 40 Hz (HSC) or 20 Hz (normal ship speed).

### Output

Radar system data	RS-232C	RSD, OSD	For PC plotter
TT data*	IEC 61162-1	TTD, TTM	For ECDIS
Remote display signal	HD, BP Trigger, Video		2 ports
Alarm signal	Contact closure	Output to alarm system by using photo-relay	4 systems, Output contents are selected by menu.

\*: The output sentence, mode and baud rate can be set at the TT Preset menu.

### IEC 61162 input sentence and priority

Contents	Sentence and priority
Heading (True)	THS*>HDT*

\*: THS and HDT are IEC61162-2 sentences.

### IEC 61162 output sentence

Contents	Sentence
Radar system data	RSD
Own ship data	OSD
TT target data	TTD, TLB, TTM

## 5.2 Chart Processor Unit

The main method for transferring data between a sensor and the Chart Processor Unit is IEC 61162-1 Ed.1 or IEC 61162-1 Ed.2 Standard serial communication link.

In the standard configuration, the system has one serial communication channel interface, LAN adapter type EC-1010, to communicate with up to eight external devices in serial format. As an option, second LAN adapter can be connected for max. 16 serial channels in total.

Optionally the Chart Processor Unit can be interface to analog signals through a B adapter type EC-1020. For communication with Chart Processor Unit this analog adapter use, one serial channel from the LAN adapter.

### Standard interfaces

#### Speed log

- One serial input type of dual-axis speed log ( IEC 61162-1 Ed.1 or Ed.2 message \$XXVBW.... or NMEA V1.5 message \$PKVBW... or NMEA V1.5 message \$PSALL, min 1 message per 2 seconds).

#### Positioning equipment

- Two positioning equipment can be connected using one of the following communication protocols:
  - IEC 61162-1 Ed.1 messages \$XXGLL, \$XXVTG and \$XXZDA
  - IEC 61162-1 Ed.1 messages \$XXGGA, \$XXVTG and \$XXZDA
  - IEC 61162-1 Ed.2 messages \$XXDTM, \$XXGLL, \$XXVTG and \$XXZDA
  - IEC 61162-1 Ed.2 messages \$XXDTM, \$XXGGA, \$XXVTG and \$XXZDA
- **Notes:**
  - Min message rate is 1 message per 5 seconds
  - Recommended rate is 1 message per second
  - Alternatives 1, 2 and 3 has separate talker identifier selection for VTG and GLL/GGA/PAT.
  - Message \$XXZDA should only be used with one of the position equipment.
  - Only alternatives 2 and 3 have Differential-flag for DGPS use.
  - Only equipment, which has fixed datum (like WGS-84) in their position message should be used. Alternatives 6 and 7 check that the used datum is WGS84.



**AIS transponder equipment**

- One serial input interface (IEC 61993-2 Ed.1 message !XXVDM, message types 1, 2, 3, 4, 5, 6, 9, 12, 14, 18, 19, 21 and 24, min 1 message per 10 seconds)
- **Notes:**
  - Max. 1500 simultaneous AIS targets can stored for display purposes.
  - Max. 240 simultaneous AIS targets out of 1500 stored can be displayed.
  - When own ship's VDO message is not received, the message "737 AIS receiver error" appears in the text window.

**Alarm ACK inputs**

- Input from alarm system (Contact closed is No Alarm)
- ACK sentence from alarm system (IEC61162-1)

**Alarm outputs**

- RADAR system failure as open contact (Contact closed is No Failure)
- ANY RADAR ALARM as open contact (Contact closed is No Alarm)
- OPERATOR FITNESS notice as closed contact (Contact open is No activity)
- ALR (alarm data) for alarm system (IEC61162-1)

**External interfaces****Positioning equipment**











- One additional positioning equipment

**Alarm outputs**



- ROUTE MONITOR: OUTSIDE CHANNEL LIMITS alarm as open contact (Contact closed is No Alarm)
- ROUTE MONITOR: WAYPOINT APPROACH alarm as open contact (Contact closed is No Alarm)
- ECHO: DEPTH BELOW LIMIT alarm as open contact (Contact closed is No Alarm)
- NAVIGATION SENSOR ALARM as open contact (Contact closed is No Alarm) from B adapter

## 5. INPUT/OUTPUT DATA

This page is intentionally left blank.

		CODE NO.	008-551-470-00	036M-X-9401-8	用途/備考 REMARKS
		TYPE	CP03-27502	1/2	
工事材料表 INSTALLATION MATERIALS					
番号 NO.	名称 NAME	略図 OUTLINE	型名/規格 DESCRIPTIONS	数量 Q'TY	
1	防蝕ゴム, 1. CORROSION-PROOF RUBBER		03-001-3001-0 ROHS CODE NO. 300-130-010-10	1	
2	シールパッキン SEAL WASHER		03-001-3002-0 ROHS CODE NO. 300-130-020-10	4	
3	操作パイプ TERMINAL OPENER		231-131 CODE NO. 000-165-800-10	1	
4	圧着端子 CRIMP-ON LUG		FV2-3 CODE NO. 000-157-246-10	2	
5	バネ座金 SPRING WASHER		M12 SUS304 CODE NO. 000-167-397-10	4	
6	フラット平座金 FLAT WASHER		M12 SUS304 CODE NO. 000-167-446-10	4	
7	六角ナット HEXAGONAL NUT		M12 SUS304 CODE NO. 000-167-491-10	4	
8	六角ナット 全長 HEXAGON HEAD SCREW		M12X60 SUS304 CODE NO. 000-162-813-10	4	
9	バネ座金 SPRING WASHER		M6 SUS304 CODE NO. 000-158-855-10	1	
10	フラット平座金 FLAT WASHER		M6 SUS304 CODE NO. 000-158-854-10	3	

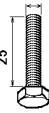
型式/コード番号が2段の場合、下段より上段に代わる標準部品であり、どちらが入っています。なお、品質は変わりません。  
TWO TYPES AND CODES MAY BE LISTED FOR AN ITEM. THE LOWER PRODUCT MAY BE SHIPPED IN PLACE OF THE UPPER PRODUCT.  
QUALITY IS THE SAME. DIMENSIONS IN DRAWING FOR REFERENCE ONLY.)

		CODE NO.	008-551-470-00	036M-X-9401-8	用途/備考 REMARKS
		TYPE	CP03-27502	2/2	
工事材料表 INSTALLATION MATERIALS					
番号 NO.	名称 NAME	略図 OUTLINE	型名/規格 DESCRIPTIONS	数量 Q'TY	
11	六角ナット HEXAGONAL NUT		M6 SUS304 CODE NO. 000-158-856-10	1	
12	六角ナット HEXAGONAL HEAD BOLT		M6X25 SUS304 CODE NO. 000-162-871-10	1	
13	ケーブル組品 CABLE ASSY.		RW-4747 RW-4747-1 CODE NO. 000-566-000-12 000-566-000-01	1	

型式/コード番号が2段の場合、下段より上段に代わる標準部品であり、どちらが入っています。なお、品質は変わりません。  
TWO TYPES AND CODES MAY BE LISTED FOR AN ITEM. THE LOWER PRODUCT MAY BE SHIPPED IN PLACE OF THE UPPER PRODUCT.  
QUALITY IS THE SAME. DIMENSIONS IN DRAWING FOR REFERENCE ONLY.)

CODE NO.	008-487-130-00	03FS-X-9403-6	1/1
TYPE	CP03-19101		

**工事材料表**

INSTALLATION MATERIALS

番号 NO.	名称 NAME	略図 OUTLINE	型名/規格 DESCRIPTIONS	数量 Q'TY	用途/備考 REMARKS
1	ピン PIN		03-141-0301-2 ROHS CODE NO. 100-266-882-10	2	
2	Oリング O-RING		JBP-135 CODE NO. 100-171-805-10	1	
3	六角スリット 六角スリット ねじB HEX HEAD SLOT BOLT-B WASHER		M8X40 SUS304 CODE NO. 1000-162-953-10	8	
4	シリコン SILICON RUBBER		S-8400W 7/8インチ*7 50G CODE NO. 1000-158-483-10	1	

型式/コード番号が2段の場合、下段より上段に代わる過渡部品であり、どちらが入っています。なお、品質は変わりません。  
TWO TYPES AND CODES MAY BE LISTED FOR AN ITEM. THE LOWER PRODUCT MAY BE SHIPPED IN PLACE OF THE UPPER PRODUCT.  
QUALITY IS THE SAME. (略図の寸法は、参考値です。 DIMENSIONS IN DRAWING FOR REFERENCE ONLY.)



CODE NO.	1008-470-020-00	0300-X-9420-4	1/1
TYPE	CP03-16411		

**工事材料表**

INSTALLATION MATERIALS

番号 NO.	名称 NAME	略図 OUTLINE	型名/規格 DESCRIPTIONS	数量 Q'TY	用途/備考 REMARKS
MARINE RADAR FOR FR-9 RECTGUIDE (FLEXIBLE WAVEGUIDE)					
1	防水フィルム WATERTIGHT FILM		03-009-0368-0 ROHS CODE NO. 300-003-680-10	1	
2	ケラント 本体 TRUK-DECK CABLE GLAND		03-009-0521-1 ROHS CODE NO. 100-207-551-10	1	
3	座金 WASHER		03-009-0522-0 ROHS CODE NO. 100-207-560-10	2	
4	パッキン (1) RUBBER PACKING		03-009-0523-0 ROHS CODE NO. 100-207-570-10	2	
5	パッキン (2) RUBBER PACKING(2)		03-009-0524-0 ROHS CODE NO. 100-207-580-10	2	
6	Oリング O-RING		ASS68-128 1115-70 CODE NO. 100-851-842-00	3	
7	ケラント 用締付 CABLE GLAND NIPPLE		JIS F8801 4B37 CODE NO. 1000-171-869-10	1	
8	六角スリット ねじB HEX HEAD SLOT BOLT-B WASHER		MAX16 SUS304 CODE NO. 1000-162-940-10	4	

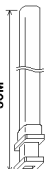
型式/コード番号が2段の場合、下段より上段に代わる過渡部品であり、どちらが入っています。なお、品質は変わりません。  
TWO TYPES AND CODES MAY BE LISTED FOR AN ITEM. THE LOWER PRODUCT MAY BE SHIPPED IN PLACE OF THE UPPER PRODUCT.  
QUALITY IS THE SAME. (略図の寸法は、参考値です。 DIMENSIONS IN DRAWING FOR REFERENCE ONLY.)





CODE NO.		0300-X-9414-2		1/1	
TYPE		レーダー用材付 (FR-9)			
RADAR RECTGUIDE					
工事材料表					
INSTALLATION MATERIALS					
番号 NO.	名称 NAME	略図 OUTLINE	型名/規格 DESCRIPTIONS	数量 Q'TY	用途/備考 REMARKS
1	FR-9用材付 WAVEGUIDE	 20M	FR-9-20 CODE NO. 000-805-738-01	1	選択 TO BE SELECTED
2	FR-9用材付 WAVEGUIDE	 30M	FR-9-30 CODE NO. 000-805-739-01	1	選択 TO BE SELECTED
3	FR-9用材付 WAVEGUIDE	 50M	FR-9-50 CODE NO. 000-805-740-01	1	選択 TO BE SELECTED

型式/コード番号が2段の場合、下段より上段に代わる通線部品であり、どちらかが入っています。なお、品質は変わりません。  
TWO TYPES AND CODES MAY BE LISTED FOR AN ITEM. THE LOWER PRODUCT MAY BE SHIPPED IN PLACE OF THE UPPER PRODUCT.  
QUALITY IS THE SAME. DIMENSIONS IN DRAWING FOR REFERENCE ONLY.)

☆

FURUNO ELECTRIC CO., LTD.

0300-X-9414

CODE NO.		008-452-540-00		03EP-X-9405-6	
TYPE		CP03-13907		1/1	
INSTALLATION MATERIALS					
工事材料表					
INSTALLATION MATERIALS					
番号 NO.	名称 NAME	略図 OUTLINE	型名/規格 DESCRIPTIONS	数量 Q'TY	用途/備考 REMARKS
1	圧着端子 CRIMP-ON LUG	 20 8	FV1.25-4(LF) CODE NO. 000-166-666-10	11	
2	圧着端子 CRIMP-ON LUG	 19 7	FV1.25-M3(LF) CODE NO. 000-166-740-10	16	
3	圧着端子 CRIMP-ON LUG	 26 10	FV5.5-4(LF) CODE NO. 000-166-744-10	19	
4	特殊付 LUG	 18 7	7744 33 7744 33 CODE NO. 000-168-321-10 000-536-100-00	2	

型式/コード番号が2段の場合、下段より上段に代わる通線部品であり、どちらかが入っています。なお、品質は変わりません。  
TWO TYPES AND CODES MAY BE LISTED FOR AN ITEM. THE LOWER PRODUCT MAY BE SHIPPED IN PLACE OF THE UPPER PRODUCT.  
QUALITY IS THE SAME. DIMENSIONS IN DRAWING FOR REFERENCE ONLY.)

FURUNO ELECTRIC CO., LTD.

03EP-X-9405



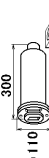



CODE NO.	038F-X-9403-6
TYPE	22XGW

工事材料表		INSTALLATION MATERIALS	
番号 NO.	名称 NAME	略図 OUTLINE	数量 Q'TY
1	導波管 WAVEGUIDE STRAIGHT		4
2	NS貫通金物組立 THRU-DECK WAVEGUIDE		1

型名/規格 DESCRIPTIONS	用途/備考 REMARKS
RWA-1020 A-107A CODE NO. 310-100-420-00	
RWG-1000-0 CODE NO. 310-710-000-00	

型式/コード番号が2段の場合、下段より上段に代わる通波部品であり、どちらかが入っています。なお、品質は変わりません。  
 TWO TYPES AND CODES MAY BE LISTED FOR AN ITEM. THE LOWER PRODUCT MAY BE SHIPPED IN PLACE OF THE UPPER PRODUCT. QUALITY IS THE SAME.  
 (略図の寸法は、参考値です。 DIMENSIONS IN DRAWING FOR REFERENCE ONLY.)

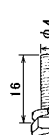
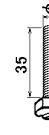
CODE NO.	1008-470-010-00
TYPE	CP03-16401

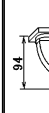
工事材料表		INSTALLATION MATERIALS	
番号 NO.	名称 NAME	略図 OUTLINE	数量 Q'TY
1	防水フィルム WATERTIGHT FILM		1
2	Oリング O-RING		20
3	ハネ座金 SPRING WASHER		35
4	シヤ丸平座金 FLAT WASHER		65
5	六角ナット HEX. NUT		35
6	六角スリッパ HEX BOLT (SLOTTED WASHER HEAD)		80
7	六角スリッパ HEX BOLT (SLOTTED HEAD)		35
8	導波管押え 3.E型 WAVEGUIDE CLAMP (3) E-TYPE		15
9	導波管保護ゴム RUBBER CUSHION		15
10	工事用WG.ハンダ WAVEGUIDE H-BEND		2

型名/規格 DESCRIPTIONS	用途/備考 REMARKS
03-009-0368-0 ROHS CODE NO. 300-903-680-10	
AS568-128 1115-70 CODE NO. 000-851-842-00	
M4 SUS304 CODE NO. 000-167-405-10	
M4 SUS304 CODE NO. 000-167-455-10	
M4 SUS304 CODE NO. 000-167-488-10	
MAX16 SUS304 CODE NO. 000-162-933-10	
MAX35 SUS304 CODE NO. 000-162-894-10	
RSB-2007-1 CODE NO. 360-220-071-00	
RWA-1011-0 ROHS CODE NO. 310-110-110-10	
RWA-1040 B-108 CODE NO. 310-100-160-00	

型式/コード番号が2段の場合、下段より上段に代わる通波部品であり、どちらかが入っています。なお、品質は変わりません。  
 TWO TYPES AND CODES MAY BE LISTED FOR AN ITEM. THE LOWER PRODUCT MAY BE SHIPPED IN PLACE OF THE UPPER PRODUCT. QUALITY IS THE SAME.  
 (略図の寸法は、参考値です。 DIMENSIONS IN DRAWING FOR REFERENCE ONLY.)

CODE NO.	008-470-010-00	03EP-X-9423 -6
TYPE	CP03-16401	2/2

## 工事材料表

### INSTALLATION MATERIALS

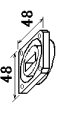
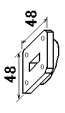
番号 NO.	名称 NAME	略図 OUTLINE	型名/規格 DESCRIPTIONS	数量 Q'TY	用途/備考 REMARKS
11	ワベぐい WABEGUI DE FLANGE		WRJ-9 CODE NO. 000-879-242-00	7	
12	かへつがし WABEGUI DE FLANGE		WRJ-9 CODE NO. 000-879-262-00	7	

型式/コード番号が2段の場合、下段より上段に代わる通線部品であり、どちらかが入っています。なお、品質は変わりません。  
 TWO TYPES AND CODES MAY BE LISTED FOR AN ITEM. THE LOWER PRODUCT MAY BE SHIPPED IN PLACE OF THE UPPER PRODUCT. QUALITY IS THE SAME.  
 (略図の寸法は、参考値です。 DIMENSIONS IN DRAWING FOR REFERENCE ONLY.)

CODE NO.	008-540-200-00	036M-X-9402 -2
TYPE	CP03-27501	1/1

## 工事材料表

### INSTALLATION MATERIALS

#### Transceiver unit RTR-081

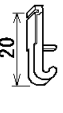
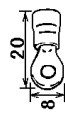
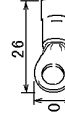
番号 NO.	名称 NAME	略図 OUTLINE	型名/規格 DESCRIPTIONS	数量 Q'TY	用途/備考 REMARKS
1	操作バネ TERMINAL OPENER		231-131 CODE NO. 000-165-800-10	1	
2	圧着端子 CRIMP-ON LUG		FV1.25-4 (LF) FV1.25-4 CODE NO. 000-166-666-10 000-538-114-00	4	
3	圧着端子 CRIMP-ON LUG		FV5.5-4 (LF) CODE NO. 000-166-744-10	1	

型式/コード番号が2段の場合、下段より上段に代わる通線部品であり、どちらかが入っています。なお、品質は変わりません。  
 TWO TYPES AND CODES MAY BE LISTED FOR AN ITEM. THE LOWER PRODUCT MAY BE SHIPPED IN PLACE OF THE UPPER PRODUCT. QUALITY IS THE SAME.  
 (略図の寸法は、参考値です。 DIMENSIONS IN DRAWING FOR REFERENCE ONLY.)

CODE NO.	008-551-460-00	038P-X-9401-7
TYPE	CP03-27602	1/2

**工事材料表**

INSTALLATION MATERIALS

番号 NO.	名称 NAME	略図 OUTLINE	型名/規格 DESCRIPTIONS	数量 Q'TY	用途/備考 REMARKS
1	シールワッシャー SEAL WASHER		03-001-300Z-0 ROHS CODE NO. 300-130-020-10	8	
2	防蝕ゴム ANTI-CORROSION RUBBER		03-029-0301-2 ROHS CODE NO. 100-091-112-10	2	
3	操作バー TERMINAL OPENER		231-131 CODE NO. 000-165-800-10	1	
4	圧着端子 CRIMP-ON LUG		FV2-3 CODE NO. 000-157-246-10	2	
5	圧着端子 CRIMP-ON LUG		FV2-4 CODE NO. 000-157-247-10	3	
6	バネ座金 SPRING WASHER		M12 SUS304 CODE NO. 000-167-397-10	8	
7	フラットワッシャー FLAT WASHER		M12 SUS304 CODE NO. 000-167-448-10	8	
8	六角ナット 1/2 HEXAGONAL NUT		M12 SUS304 CODE NO. 000-167-491-10	16	
9	六角ナット 全社 HEXAGONAL HEAD SCREW		M12X70 SUS304 CODE NO. 000-162-814-10	8	
10	バネ座金 SPRING WASHER		M6 SUS304 CODE NO. 000-158-855-10	1	

型式/コード番号が2段の場合、下段より上段に代わる標準部品であり、どちらが入っています。なお、品質は変わりません。  
TWO TYPES AND CODES MAY BE LISTED FOR AN ITEM. THE LOWER PRODUCT MAY BE SHIPPED IN PLACE OF THE UPPER PRODUCT. QUALITY IS THE SAME.  
(略図の寸法は、参考値です。 DIMENSIONS IN DRAWING FOR REFERENCE ONLY.)

CODE NO.	008-551-460-00	038P-X-9401-7
TYPE	CP03-27602	2/2

**工事材料表**

INSTALLATION MATERIALS

番号 NO.	名称 NAME	略図 OUTLINE	型名/規格 DESCRIPTIONS	数量 Q'TY	用途/備考 REMARKS
11	フラットワッシャー FLAT WASHER		M6 SUS304 CODE NO. 000-158-854-10	3	
12	六角ナット 1/2 HEXAGONAL NUT		M6 SUS304 CODE NO. 000-158-856-10	1	
13	六角ナット HEXAGONAL HEAD BOLT		M6X25 SUS304 CODE NO. 000-162-871-10	1	
14	ケーブル組品 CABLE ASSY.		RW-4747 RW-4747-1 CODE NO. 000-566-000-12 000-566-000-01	1	

型式/コード番号が2段の場合、下段より上段に代わる標準部品であり、どちらが入っています。なお、品質は変わりません。  
TWO TYPES AND CODES MAY BE LISTED FOR AN ITEM. THE LOWER PRODUCT MAY BE SHIPPED IN PLACE OF THE UPPER PRODUCT. QUALITY IS THE SAME.  
(略図の寸法は、参考値です。 DIMENSIONS IN DRAWING FOR REFERENCE ONLY.)







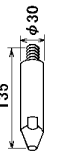

# FURUNO

CODE NO.	1008-254-590-00	0300-X-9421 -5
TYPE		1/1

## 工事材料表

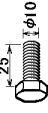
SNS6AF/7AF/7AF-MSA/30AF/36AF

番号 NO.	名称 NAME	略図 OUTLINE	型名/規格 DESCRIPTIONS		数量 Q'TY	用途/備考 REMARKS
			CODE NO.			
1	ガイドピン GUIDE PIN		03-006-408-1-0 ROHS		2	
			CODE NO.	300-640-810-10		
2	Oリング O-RING		JB1AG-60		2	
			CODE NO.	000-851-309-00		
3	フラットワッシャー FLAT WASHER		M10 SUS304		10	
			CODE NO.	000-167-232-10		
4	スプリングワッシャー SPRING WASHER		M10 SUS304		10	
			CODE NO.	000-167-233-10		
5	六角ボルト HEXAGONAL HEAD BOLT		M10X25 SUS304		10	
			CODE NO.	000-162-760-10		
6	シリコンゴム SILICON RUBBER		S-8400W 7x3x1.7 50G		1	
			CODE NO.	000-158-483-10		
			CODE NO.	000-158-483-00		



型式/コード番号が2段の場合、下段より上段に代わる標準部品であり、どちらが入っています。なお、品質は変わりません。  
TWO TYPES AND CODES MAY BE LISTED FOR AN ITEM. THE LOWER PRODUCT MAY BE SHIPPED IN PLACE OF THE UPPER PRODUCT.  
QUALITY IS THE SAME.  
(略図の寸法は、参考値です。)

# FURUNO

CODE NO.	008-538-730-00	0360-X-9501 -1
TYPE	FP03-10101	1/1

## 付属品表

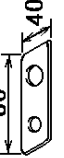
ACCESSORIES

番号 NO.	名称 NAME	略図 OUTLINE	型名/規格 DESCRIPTIONS		数量 Q'TY	用途/備考 REMARKS
			CODE NO.			
1	吊り上げ金具 LIFTING FIXTURE		03-015-3233-0 ROHS		2	
			CODE NO.	100-090-720-10		
2	取付用カク COLLAR FOR LIFTING FIXTURE		03-015-3234-0 ROHS		2	
			CODE NO.	100-090-730-10		

型式/コード番号が2段の場合、下段より上段に代わる標準部品であり、どちらが入っています。なお、品質は変わりません。  
TWO TYPES AND CODES MAY BE LISTED FOR AN ITEM. THE LOWER PRODUCT MAY BE SHIPPED IN PLACE OF THE UPPER PRODUCT.  
QUALITY IS THE SAME.  
(略図の寸法は、参考値です。)

CODE NO.	008-198-600-00	03BF-X-9417-8	03EP-X-9425-5
TYPE	PA-5600		CP03-13948

工事材料表 INSTALLATION MATERIALS		MARINE RADAR 同軸ケーブル工事用 RADAR COAX CABLE INSTALLATION	
番号 NO.	名称 NAME	略図 OUTLINE	数量 Q'TY
1	変換器組品 COUPLER		2
2	O-RING		1
3	六角ナット 1種 HEX. NUT		6
4	フラットワッシャー FLAT WASHER		22
5	スプリングワッシャー SPRING WASHER		6
6	六角ボルト 1種 HEX. BOLT (SLOTTED HEAD)		16
7	六角ボルト 2種 HEX. BOLT (SLOTTED HEAD)		6

型式/コード番号が2段の場合、下段より上段に代わる標準部品であり、どちらが入っています。なお、品質は変わりません。  
TWO TYPES AND CODES MAY BE LISTED FOR AN ITEM. THE LOWER PRODUCT MAY BE SHIPPED IN PLACE OF THE UPPER PRODUCT.  
QUALITY IS THE SAME. DIMENSIONS IN DRAWING FOR REFERENCE ONLY.)

CODE NO.	008-452-970-00	03EP-X-9425-5
TYPE	CP03-13948	1/1

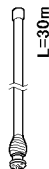

工事材料表 INSTALLATION MATERIALS		MARINE RADAR 同軸ケーブル工事用 RADAR COAX CABLE INSTALLATION	
番号 NO.	名称 NAME	略図 OUTLINE	数量 Q'TY
1	加工ケーブル GAUGE		1
2	7HESFテープ PLASTIC S TAPE		1
3	7HENVテープ PLASTIC N TAPE		1
4	ケーブル用球状コネクタ CABLE CONNECTOR		1
5	ケーブル用バンド CABLE BAND		20

型式/コード番号が2段の場合、下段より上段に代わる標準部品であり、どちらが入っています。なお、品質は変わりません。  
TWO TYPES AND CODES MAY BE LISTED FOR AN ITEM. THE LOWER PRODUCT MAY BE SHIPPED IN PLACE OF THE UPPER PRODUCT.  
QUALITY IS THE SAME. DIMENSIONS IN DRAWING FOR REFERENCE ONLY.)

		CODE NO.	038P-X-9403 -0		1/1
		TYPE			
工事材料表					
INSTALLATION MATERIALS					
番号 NO.	名称 NAME	略図 OUTLINE	型名/規格 DESCRIPTIONS	数量 Q'TY	用途/備考 REMARKS
1	ケーブル組品 CABLE ASSY.	 L=20m	LHPX-20D-ASSY(20M)	1	選択 TO BE SELECTED
			CODE NO. 000-142-291		
2	ケーブル組品 CABLE ASSY.	 L=30m	LHPX-20D-ASSY(30M)	1	選択 TO BE SELECTED
			CODE NO. 000-142-292		

038P-X-9403

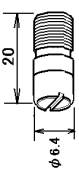
FURUNO ELECTRIC CO., LTD.  
(略図の寸法は、参考値です。 DIMENSIONS IN DRAWING FOR REFERENCE ONLY.)

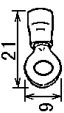
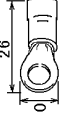

		CODE NO.	008-540-570-00		038P-X-9402 -3
		TYPE	CP03-27601		1/1
工事材料表					
INSTALLATION MATERIALS					
番号 NO.	名称 NAME	略図 OUTLINE	型名/規格 DESCRIPTIONS	数量 Q'TY	用途/備考 REMARKS
1	位置決めピン(φ) PIN		03-163-3814-1 ROHS	2	
			CODE NO. 100-315-801-10 100-315-801-00		
2	操作いへん TERMINAL OPENER		Z31-131	1	
			CODE NO. 000-165-800-10		
3	圧着端子 CRIMP-ON LUG		FV2-4	6	
			CODE NO. 000-157-247-10		
4	圧着端子 CRIMP-ON LUG		FV5.5-4(LF)	1	
			CODE NO. 000-166-744-10		

型式/コード番号が2段の場合、下段より上段に代わる通線部品であり、どちらが入っています。なお、品質は変わりません。  
TWO TYPES AND CODES MAY BE LISTED FOR AN ITEM. THE LOWER PRODUCT MAY BE SHIPPED IN PLACE OF THE UPPER PRODUCT. QUALITY IS THE SAME.  
(略図の寸法は、参考値です。 DIMENSIONS IN DRAWING FOR REFERENCE ONLY.)

FURUNO ELECTRIC CO., LTD.

038P-X-9402

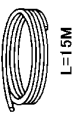
CODE NO.	038L-X-9401-6
TYPE	1/1

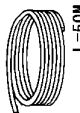
工事材料表		INSTALLATION MATERIALS		FAR-21**/28**, FOR-21**/28**	
番号 NO.	名称 NAME	略図 OUTLINE	型名/規格 DESCRIPTIONS	数量 Q'TY	用途/備考 REMARKS
1	ケーブル(14C) 14-CORE CABLE	 L=15M	RW-9600 *15M* CODE NO. 001-078-400-10	1	選択 TO BE SELECTED 標準ケーブル SIGNAL CABLE
2	ケーブル(14C) 14-CORE CABLE	 L=30M	RW-9600 *30M* CODE NO. 001-078-410-10	1	選択 TO BE SELECTED 標準ケーブル SIGNAL CABLE
3	ケーブル(14C) 14-CORE CABLE	 L=40M	RW-9600 *40M* CODE NO. 001-078-420-10	1	選択 TO BE SELECTED 標準ケーブル SIGNAL CABLE
4	ケーブル(14C) 14-CORE CABLE	 L=50M	RW-9600 *50M* CODE NO. 001-078-430-10	1	選択 TO BE SELECTED 標準ケーブル SIGNAL CABLE

型式/コード番号が2段の場合、下段より上段に代わる通線部品であり、どちらかが入っています。なお、品質は変わりません。  
TWO TYPES AND CODES MAY BE LISTED FOR AN ITEM. THE LOWER PRODUCT MAY BE SHIPPED IN PLACE OF THE UPPER PRODUCT.  
QUALITY IS THE SAME.  
(略図の寸法は、参考値です。 DIMENSIONS IN DRAWING FOR REFERENCE ONLY.)

CODE NO.	008-559-540-00
TYPE	CP03-31101

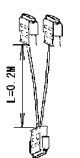
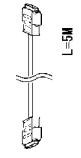
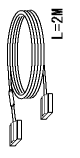
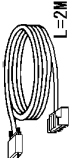
工事材料表		INSTALLATION MATERIALS		FOR-21**/28**	
番号 NO.	名称 NAME	略図 OUTLINE	型名/規格 DESCRIPTIONS	数量 Q'TY	用途/備考 REMARKS
1	EMIコブ EMI CORE	 56 34	RFC-10 CODE NO. 000-141-085-10	1	
2	コネクタ組品 CONNECTOR ASSY.	 L=0.2M	DSUB9P3-A CODE NO. 000-150-677-11	1	
3	コネクタ組品 CONNECTOR ASSY.	 L=5M	DSUB9P-DSUB9P-L5.0M CODE NO. 000-150-675-11	1	
4	ケーブル組品LAN LAN CABLE ASSEMBLY	 L=2M	MD-2072-020+ CODE NO. 000-167-175-10	3	
5	ケーブル組品 CABLE ASSY.	 L=2M	XH10P-DSQP-2000 CODE NO. 000-157-156-11	1	

型式/コード番号が2段の場合、下段より上段に代わる通線部品であり、どちらかが入っています。なお、品質は変わりません。  
TWO TYPES AND CODES MAY BE LISTED FOR AN ITEM. THE LOWER PRODUCT MAY BE SHIPPED IN PLACE OF THE UPPER PRODUCT.  
QUALITY IS THE SAME.  
(略図の寸法は、参考値です。 DIMENSIONS IN DRAWING FOR REFERENCE ONLY.)

PACKING LIST

MU-231CE-DVI5

A-22

NAME	OUTLINE	DESCRIPTION/CODE No.	QTY
<b>ユニット</b>			
表示部 DISPLAY UNIT		MU-231CE 000-083-405-00	1
<b>予備品</b>			
予備品 SPARE PARTS		SPO3-14700 008-549-730-00	1
<b>付属品</b>			
付属品 ACCESSORIES		FP03-09810 008-536-010-00	1
<b>工事材料</b>			
<b>DVIケーブル</b>			
DVI CABLE		CABLE DIGITAL DVI 5M 999-999-137-00	1 (*1)
ケーブル組品 CABLE ASSEMBLY		00619-001 000-171-765-10	1
<b>図書</b>			
取扱説明書 OPERATOR'S MANUAL		OMC-41222-* 000-159-669-1*	1

(\*1)は、がミコードに付き、注文できません。  
(\*1) THIS CODE CANNOT BE ORDERED.

型式/コード番号が2段の場合、下段より上段に代わる過渡期品であり、どちらかが入っています。なお、品質は変わりません。  
TWO TYPES AND CODES MAY BE LISTED FOR AN ITEM. THE LOWER PRODUCT MAY BE SHIPPED IN PLACE OF THE UPPER PRODUCT. QUALITY IS THE SAME.  
(略図の寸法は、参考値です。DIMENSIONS IN DRAWING FOR REFERENCE ONLY.) 03GR-X-9852

A-21

CODE NO.	008-559-550-00		038U-X-9402-3	1/1	
	TYPE	CP03-31102			
<b>工事材料表</b>					
INSTALLATION MATERIALS					
FOR-21**/28**					
番号 NO.	名称 NAME	略図 OUTLINE	型名/規格 DESCRIPTIONS	数量 QTY	用途/備考 REMARKS
1	EMIコブ EMI CORE		RFC-10 CODE NO. 000-141-085-10	1	
2	ケーブル組品 CONNECTOR ASSY.		DSUB9P3-A CODE NO. 000-150-677-11	1	
3	ケーブル組品 CONNECTOR ASSY.		DSUB9P-DSUB9P-L10.0M CODE NO. 000-150-676-11	1	
4	ケーブル組品LAN LAN CABLE ASSEMBLY		MOD-2072-020+ CODE NO. 000-167-175-10	3	
5	ケーブル組品 CABLE ASSY.		XH10P-DS9P-2000 CODE NO. 000-157-156-11	1	

型式/コード番号が2段の場合、下段より上段に代わる過渡期品であり、どちらかが入っています。なお、品質は変わりません。  
TWO TYPES AND CODES MAY BE LISTED FOR AN ITEM. THE LOWER PRODUCT MAY BE SHIPPED IN PLACE OF THE UPPER PRODUCT. QUALITY IS THE SAME.  
(略図の寸法は、参考値です。DIMENSIONS IN DRAWING FOR REFERENCE ONLY.)

FURUNO ELECTRIC CO., LTD. 038U-X-9402

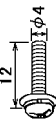
CODE NO.		008-539-850-00		03GL-X-9411-1	
TYPE		CP03-25604		1/1	
工事材料表 INSTALLATION MATERIALS					
番号 NO.	名称 NAME	略図 OUTLINE	型名/規格 DESCRIPTIONS	数量 Q'TY	用途/備考 REMARKS
1	ナナハセムズB WASHER HEAD SCREW *B*		MAX12 C2700W MBN12 CODE NO. 000-163-192-10	4	



型式/コード番号が2段の場合、下段より上段に代わる過渡期品であり、どちらが入っています。なお、品質は変わりません。  
TWO TYPES AND CODES MAY BE LISTED FOR AN ITEM. THE LOWER PRODUCT MAY BE SHIPPED IN PLACE OF THE UPPER PRODUCT. QUALITY IS THE SAME.  
(略図の寸法は、参考値です。DIMENSIONS IN DRAWING FOR REFERENCE ONLY.)

## PACKING LIST FCR-21\*\*/28\*\* (EC-1000C-\*)

NAME	OUTLINE	DESCRIPTION/CODE No.	Q'TY
<b>ユニット UNIT</b>			
ECDIS LAN7*アダプタ ECDIS LAN ADAPTER		EC-1010-FGR 000-011-789-00	1
制御部 PROCESSOR UNIT		EC-1000C-** 000-080-582-00	1
<b>予備品 SPARE PARTS</b>			
予備品 SPARE PARTS		SP03-14800 000-083-570-00	1
<b>付属品 ACCESSORIES</b>			
CD-ROM CD-ROM		2450036 001-007-380-00	1
CD-ROM (06. **) FCR SOFTWARE (CD-ROM) (06. **)		0359233 001-020-260-01	1
FD-ROM FD-ROM		2450037 001-007-380-00	1
PS/2分配ケーブル PS/2 KEYBOARD/MOUSE Y CABLE		ASYG-CABLE-FU-PS2 000-173-402-10	1
キーボード KEYBOARD		WK750P 000-168-795-10	1
マウス MOUSE		KM-731 000-172-978-00	1
<b>工事材料 INSTALLATION MATERIALS CP03-29100</b>			
ナナハセムズB WASHER HEAD SCREW (B)		MAX8 C2700W MBN12 000-163-200-10	14

1.コード番号末尾の[\*\*]は、選択品の代表コードを表します。  
CODE NUMBER ENDING WITH "\*\*" INDICATES THE CODE NUMBER OF REPRESENTATIVE MATERIAL.  
2.(\*)は、タミコードに付き、注文できません。  
(\*) THIS CODE CANNOT BE ORDERED.

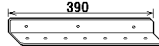
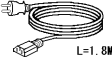
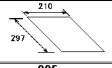
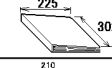
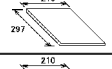
(略図の寸法は、参考値です。DIMENSIONS IN DRAWING FOR REFERENCE ONLY.)

NAME	OUTLINE	DESCRIPTION/CODE No.	Q'TY
取付板 MOUNTING PLATE		14-058-2081-2 000-321-552-10	2
<b>工事材料 INSTALLATION MATERIALS</b>			
電源ケーブル POWER CABLE		K15031651836R 000-164-988-00	1
<b>図書 DOCUMENT</b>			
ドングルインフォメーションシート DONGLE INFORMATION SHEET		999-999-085-0* 00E-35590-*	1 (*1)
取扱説明書 OPERATOR'S MANUAL		00E-35590-* 000-158-041-1*	1
操作要領書 OPERATOR'S GUIDE		00E-35590-* 000-158-045-1*	1
装備要領書 INSTALLATION MANUAL		IME-35590/35610/35640-* 000-158-058-1*	1 **

型式/コード番号が2段の場合、下段より上段に代わる過渡期品であり、どちらが入っています。なお、品質は変わりません。  
TWO TYPES AND CODES MAY BE LISTED FOR AN ITEM. THE LOWER PRODUCT MAY BE SHIPPED IN PLACE OF THE UPPER PRODUCT. QUALITY IS THE SAME.

CODE NO.	009-535-610-00	036L-X-9505-7
TYPE	FP03-09850	1/1

## 付属品表

### ACCESSORIES

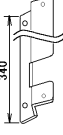
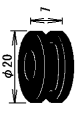
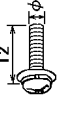
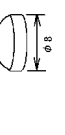
番号 NO.	名称 NAME	略図 OUTLINE	型名/規格 DESCRIPTIONS	数量 Q'TY	用途/備考 REMARKS
1	KB直付金具 KB FIXING METAL		03-163-1521-1 ROHS CODE NO. 100-306-251-10	1	操作部用 FOR CONTROL UNIT
2	ワシパ GROMMET		G-39 CODE NO. 000-166-401-10	1	操作部用 FOR CONTROL UNIT
3	ワシパ、ワシ WASHER HEAD SCREW *B*		MAX12 C2700W MBN12 CODE NO. 000-163-192-10	2	操作部用 FOR CONTROL UNIT
4	ワシパ、ワシ CUSHION		TM-180-302 CODE NO. 000-166-468-10	3	操作部用 FOR CONTROL UNIT



型式/コード番号が2段の場合、下段より上段に代わる通称部品であり、どちらかが入っています。なお、品質は変わりません。  
TWO TYPES AND CODES MAY BE LISTED FOR AN ITEM. THE LOWER PRODUCT MAY BE SHIPPED IN PLACE OF THE UPPER PRODUCT. QUALITY IS THE SAME.  
(略図の寸法は、参考値です。 DIMENSIONS IN DRAWING FOR REFERENCE ONLY.)

CODE NO.	008-535-940-00	036L-X-9405-2
TYPE	CP03-25602	1/1

## 工事材料表

For RPU-016

### INSTALLATION MATERIALS

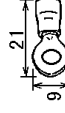
番号 NO.	名称 NAME	略図 OUTLINE	型名/規格 DESCRIPTIONS	数量 Q'TY	用途/備考 REMARKS
1	操作バネ TERMINAL OPENER		231-131 CODE NO. 000-165-800-10	1	制御部用 FOR PROCESSOR UNIT
2	操作バネ TERMINAL OPENER		734-230 CODE NO. 000-147-417-10	1	制御部用 FOR PROCESSOR UNIT
3	圧着端子 CRIMP-ON LUG		FV2-4 CODE NO. 000-157-247-10	2	制御部用 FOR PROCESSOR UNIT

型式/コード番号が2段の場合、下段より上段に代わる通称部品であり、どちらかが入っています。なお、品質は変わりません。  
TWO TYPES AND CODES MAY BE LISTED FOR AN ITEM. THE LOWER PRODUCT MAY BE SHIPPED IN PLACE OF THE UPPER PRODUCT. QUALITY IS THE SAME.  
(略図の寸法は、参考値です。 DIMENSIONS IN DRAWING FOR REFERENCE ONLY.)

CODE NO.	008-535-690-00	036L-X-9506-7
TYPE	FP03-09860	1/1

### 付属品表

For RCU-015FEA016 desktop mount kit

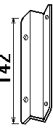
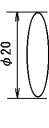
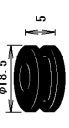
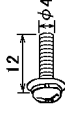
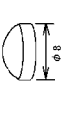



番号 NO.	名称 NAME	略図 OUTLINE	型名/規格 DESCRIPTIONS	数量 Q'TY	用途/備考 REMARKS
1	キーボード付金具(T) KEYBOARD FIXTURE		03-163-7821-1 ROHS CODE NO. 100-306-291-10	1	操作部用 FOR CONTROL UNIT
2	ブラインドシール BLIND SEAL		22-020-1005-1 ROHS CODE NO. 100-173-591-10	3	操作部用 FOR CONTROL UNIT
3	グロメット GROMMET		G-49 CODE NO. 100-166-406-10	1	操作部用 FOR CONTROL UNIT
4	六角洗剤 WASHER HEAD SCREW *B*		MAX12 C2700W MBN12 CODE NO. 100-163-192-10	2	操作部用 FOR CONTROL UNIT
5	リブフット RUBBER FOOT		TM-180-302 CODE NO. 100-166-468-10	2	操作部用 FOR CONTROL UNIT

型式/コード番号が2段の場合、下段より上段に代わる過渡部品であり、どちらかが入っています。なお、品質は変わりません。  
TWO TYPES AND CODES MAY BE LISTED FOR AN ITEM. THE LOWER PRODUCT MAY BE SHIPPED IN PLACE OF THE UPPER PRODUCT. QUALITY IS THE SAME.  
(略図の寸法は、参考値です。 DIMENSIONS IN DRAWING FOR REFERENCE ONLY.)

CODE NO.	008-535-630-00	036L-X-9503-6
TYPE	FP03-09870	1/1

### 付属品表

For RCU-020/015FEA/016 Flush mount kit

番号 NO.	名称 NAME	略図 OUTLINE	型名/規格 DESCRIPTIONS	数量 Q'TY	用途/備考 REMARKS
1	フラッシュマウント金具 FLUSH MOUNTING PLATE		03-163-7531-1 ROHS CODE NO. 100-306-261-10	4	
2	六角洗剤 WASHER HEAD SCREW *B*		MAX12 C2700W MBN12 CODE NO. 100-163-192-10	4	
3	六角ナット 1種 HEX. NUT		MG SUS304 CODE NO. 100-165-921-10	4	
4	蝶ネット WING SCREW		MGX40 SUS304 CODE NO. 100-162-682-10	4	

型式/コード番号が2段の場合、下段より上段に代わる過渡部品であり、どちらかが入っています。なお、品質は変わりません。  
TWO TYPES AND CODES MAY BE LISTED FOR AN ITEM. THE LOWER PRODUCT MAY BE SHIPPED IN PLACE OF THE UPPER PRODUCT. QUALITY IS THE SAME.  
(略図の寸法は、参考値です。 DIMENSIONS IN DRAWING FOR REFERENCE ONLY.)



CODE NO.	008-535-560-00	036L-X-9501-5
TYPE	FP03-09820	1/1

付属品表		ACCESSORIES			
番号 NO.	名称 NAME	略図 OUTLINE	型名/規格 DESCRIPTIONS	数量 Q'TY	用途/備考 REMARKS
1	ハカ-L (20) HANGER L		03-163-1111-1 ROHS 03-163-1111-1 CODE NO. 100-305-141-10 100-305-141-00	1	
2	ハカ-R (20) HANGER R		03-163-1112-1 ROHS 03-163-1112-1 CODE NO. 100-305-181-10 100-305-181-00	1	
3	ハカ-押柱 (20) HANGER STAY		03-163-1113-1 ROHS CODE NO. 100-305-191-10	1	
4	ホヅラガ HOLE PLUG		CP-30-HP-13 CODE NO. 000-160-074-10	2	
5	スナツボ SNAP BUTTON		KB-133P ホツボ CODE NO. 000-570-276-10	4	
6	フラツバ FLAT WASHER		M10 SUS304 CODE NO. 000-167-232-10	2	
7	バネ座金 SPRING WASHER		M10 SUS304 CODE NO. 000-167-233-10	2	
8	六角ボルト HEX. BOLT		M10X30 SUS304 CODE NO. 000-162-884-10	2	
9	六角ボルト (SLOTTED WASHER HEAD)		M6X25 SUS304 CODE NO. 000-162-949-10	4	

型式/コード番号が2段の場合、下段より上段に代わる通称部品であり、どちらが入っています。なお、品質は変わりません。  
TWO TYPES AND CODES MAY BE LISTED FOR AN ITEM. THE LOWER PRODUCT MAY BE SHIPPED IN PLACE OF THE UPPER PRODUCT.  
QUALITY IS THE SAME.  
(略図の寸法は、参考値です。 DIMENSIONS IN DRAWING FOR REFERENCE ONLY.)

CODE NO.	008-536-020-00	036M-X-9501-5
TYPE	FP03-09830	1/1

付属品表		ACCESSORIES			
番号 NO.	名称 NAME	略図 OUTLINE	型名/規格 DESCRIPTIONS	数量 Q'TY	用途/備考 REMARKS
1	ハカ-L (20) HANGER L		03-163-1111-1 ROHS 03-163-1111-1 CODE NO. 100-305-141-10 100-305-141-00	1	
2	ハカ-R (20) HANGER R		03-163-1112-1 ROHS 03-163-1112-1 CODE NO. 100-305-181-10 100-305-181-00	1	
3	ハカ-押柱 (20) HANGER STAY		03-163-2071-1 ROHS CODE NO. 100-305-371-10	1	
4	ホヅラガ HOLE PLUG		CP-30-HP-13 CODE NO. 000-160-074-10	2	
5	スナツボ SNAP BUTTON		KB-133P ホツボ CODE NO. 000-570-276-10	4	
6	フラツバ FLAT WASHER		M10 SUS304 CODE NO. 000-167-232-10	2	
7	バネ座金 SPRING WASHER		M10 SUS304 CODE NO. 000-167-233-10	2	
8	六角ボルト HEX. BOLT		M10X30 SUS304 CODE NO. 000-162-884-10	2	
9	六角ボルト (SLOTTED WASHER HEAD)		M6X25 SUS304 CODE NO. 000-162-949-10	4	

型式/コード番号が2段の場合、下段より上段に代わる通称部品であり、どちらが入っています。なお、品質は変わりません。  
TWO TYPES AND CODES MAY BE LISTED FOR AN ITEM. THE LOWER PRODUCT MAY BE SHIPPED IN PLACE OF THE UPPER PRODUCT.  
QUALITY IS THE SAME.  
(略図の寸法は、参考値です。 DIMENSIONS IN DRAWING FOR REFERENCE ONLY.)

NAME	OUTLINE	DESCRIPTION/CODE No.	Q'TY
<b>予備品 SPARE PARTS</b>			
予備品 SPARE PARTS		SP03-13300 008-419-280-00	1
<b>その他部品 OTHER PARTS</b>			
GCカバー組品 GC COVER ASSY.		80-0665 008-537-030-00	1
NHコネクタ NH CONNECTOR ASSY.		03-2091 (5P) 008-534-670-00	1
VHコネクタ VH CONNECTOR ASSY.		03-2090 (3P) 008-534-660-00	1
VHコネクタ VH CONNECTOR ASSY.		03-2089 (5P) 008-534-650-00	1
XH-PHコネクタ XH-PH CONNECTOR ASSY.		03-2088 (6-14P) 008-534-640-00	1
演算プリント PROCESSOR BOARD		64P1106A (LF) 004-655-920-00	1
ナナハセムスB WASHER HEAD SCREW (B)		M4X8 C2700W MBN12 000-163-200-10	3

NAME	OUTLINE	DESCRIPTION/CODE No.	Q'TY
ナナハセムスB WASHER HEAD SCREW		M3X8 C2700W MBN12 000-163-190-10	5
ナナハセムスA WASHER HEAD SCREW		M2.6X10 C2700W MBN12 000-163-477-10	2
コネクタ (231) CONNECTOR		231-607/019-FUR 000-147-414-11	1
コネクタ (231) CONNECTOR		231-107/026-FUR 000-147-413-11	1

(略図の寸法は、参考値です。DIMENSIONS IN DRAWING FOR REFERENCE ONLY.)

型式/コード番号が2段の場合、下段より上段に代わる過渡期品であり、どちらかが入っています。なお、品質は変わりません。

TWO TYPES AND CODES MAY BE LISTED FOR AN ITEM. THE LOWER PRODUCT MAY BE SHIPPED IN PLACE OF THE UPPER PRODUCT. QUALITY IS THE SAME.

03GL-X-9852

A-31

CODE NO.	TYPE	For MU-2010E/MU-2310E	略図 OUTLINE	型名/規格 DESCRIPTIONS	数量 Q'TY	用途/備考 REMARKS
008-535-570-00	FP03-09840	Option		14-002-1125-2 ROHS CODE NO. 840-211-262-10	2	
				M6 C2700W ホリソール CODE NO. 000-165-694-10 000-364-910-00	4	
				M6X20 C2700W ホリソール CODE NO. 000-163-677-10	4	
				MW-6 SUS CODE NO. 000-167-384-10	4	

付属品表

ACCESSORIES

型式/コード番号が2段の場合、下段より上段に代わる過渡期品であり、どちらかが入っています。なお、品質は変わりません。  
TWO TYPES AND CODES MAY BE LISTED FOR AN ITEM. THE LOWER PRODUCT MAY BE SHIPPED IN PLACE OF THE UPPER PRODUCT. QUALITY IS THE SAME.  
(略図の寸法は、参考値です。DIMENSIONS IN DRAWING FOR REFERENCE ONLY.)

03GL-X-9852

FURUNO ELECTRIC CO., LTD.

# FURUNO

CODE NO. 008-535-910  
TYPE SP03-14404  
BOX NO. P  
03GL-X-9305 -1 1/1  
SETS PER VESSEL

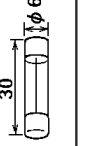
SHIP NO.	SPARE PARTS LIST FOR			U S E		REMARKS/CODE NO.
	NAME OF PART	OUTLINE	DWG. NO. OR TYPE NO.	WORKING PER SET	SPARE	
1	1 FUSE		FC800-125V 10A PBF		4	AC100V FOR PROCESSOR UNIT 000-155-826-10
MFR'S NAME	FURUNO ELECTRIC CO., LTD.			DWG NO.	03GL-X-9305	1/1

(略図の寸法は、参考値です。 DIMENSIONS IN DRAWING FOR REFERENCE ONLY.)  
型式/寸法'番号が2段の場合、下段より上段に代わる通電部品であり、どちらが入っています。 なお、品質は変わりません。  
TWO TYPES AND CODES MAY BE LISTED FOR AN ITEM. THE LOWER PRODUCT MAY BE SHIPPED IN PLACE OF THE UPPER PRODUCT. QUALITY IS THE SAME.

# FURUNO

CODE NO. 008-485-360  
TYPE SP03-12501  
BOX NO. P  
03FS-X-9301 -4 1/1  
SETS PER VESSEL

SHIP NO.	SPARE PARTS LIST FOR			U S E		REMARKS/CODE NO.
	NAME OF PART	OUTLINE	DWG. NO. OR TYPE NO.	WORKING PER SET	SPARE	
1	1 CARBON BRUSH		MG120-5X6X11 DBG		2	000-631-716
MFR'S NAME	FURUNO ELECTRIC CO., LTD.			DWG NO.	03FS-X-9301	1/1

(略図の寸法は、参考値です。 DIMENSIONS IN DRAWING FOR REFERENCE ONLY.)

# FURUNO

CODE NO.	000-083-570	03GR-X-9301 -2 1/1
TYPE	SPO3-14800	BOX NO. P

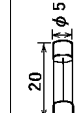
SHIP NO.		SPARE PARTS LIST FOR		U S E		REMARKS/CODE NO.	
			For EC-1000				
ITEM NO.	NAME OF PART	OUTLINE	DWG. NO. OR TYPE NO.	QUANTITY		REMARKS/CODE NO.	
				WORKING PER SET	SPARE		
1	E <sub>t</sub> -X <sup>1</sup> FUSE		FGMB 250V 5A PBF		4		
						000-157-570	
				MFR'S NAME	FURUNO ELECTRIC CO., LTD.	DWG NO.	03GR-X-9301
							1/1

(略図の寸法は、参考値です。 DIMENSIONS IN DRAWING FOR REFERENCE ONLY.)

# FURUNO

CODE NO.	008-535-920-00	03GL-X-9306 -1 1/1
TYPE	SPO3-14405	BOX NO. P

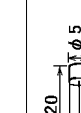
SHIP NO.		SPARE PARTS LIST FOR		U S E		REMARKS/CODE NO.	
ITEM NO.	NAME OF PART	OUTLINE	DWG. NO. OR TYPE NO.	QUANTITY		REMARKS/CODE NO.	
				WORKING PER SET	SPARE		
1	E <sub>t</sub> -X <sup>1</sup> FUSE		AC220用 FOR PROFESSOR UNIT		4		
			FGBO 250V 5A PBF			000-155-840-10	
				MFR'S NAME	FURUNO ELECTRIC CO., LTD.	DWG NO.	03GL-X-9306
							1/1

(略図の寸法は、参考値です。 DIMENSIONS IN DRAWING FOR REFERENCE ONLY.)

型式/欠番号が2段の場合、下段より上段に代わる過渡期品であり、どちらが入っています。 なお、品質は最上段の品質と同等です。 UPPER PRODUCT. QUALITY IS THE SAME.  
 TWO TYPES AND CODES MAY BE LISTED FOR AN ITEM. THE LOWER PRODUCT MAY BE SHIPPED IN PLACE OF THE UPPER PRODUCT. QUALITY IS THE SAME.

**FURUNO**

CODE NO. 008-419-280-00 030L-X-9302-2 1/1  
 TYPE SPO3-13300 BOX NO. P

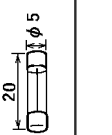
SHIP NO.		SPARE PARTS LIST FOR		U S E				SETS PER VESSEL	
ITEM NO.	NAME OF PART	OUTLINE	DWG. NO. OR TYPE NO.	QUANTITY		REMARKS/CODE NO.			
				WORKING PER SET	SPARE PER VES	WORKING PER SET	SPARE PER VESSEL		
1	Ea-X FUSE	 20 $\phi$ 5	F06B 250V 2A PBF ..... F06B 2A 250V	8			000-157-497-10 000-122-000-00		
MFR'S NAME	FURUNO ELECTRIC CO., LTD.		DWG NO.	030L-X-9302			1/1		

(図面の寸法は、参考値です。 DIMENSIONS IN DRAWING FOR REFERENCE ONLY.)  
 型式/寸法'番号が2段の場合、下段より上段に代わる通達用品であり、どちらが入っています。 なお、品質は差  
 わりません。  
 TWO TYPES AND CODES MAY BE LISTED FOR AN ITEM. THE LOWER PRODUCT MAY BE SHIPPED IN PLACE OF THE  
 UPPER PRODUCT. QUALITY IS THE SAME.

E ↓

表 2 TABLE 2

機種 ANT. TYPE	200cm型TYPE (XN20AF)	240cm型TYPE (XN24AF)
空中線長 (A) ANT. LENGTH	2,040±10mm	2,550±10mm
回線安全スペース(B) ANT. CLEARANCE	2,200mm	2,700mm
質量 MASS	40kg	42kg



表 1 TABLE 1

寸法区分 (mm) DIMENSIONS	公差 (mm) TOLERANCE
L ≤ 50	± 1.5
50 < L ≤ 100	± 2.5
100 < L ≤ 500	± 3
500 < L ≤ 1000	± 4
1000 < L ≤ 2000	± 5
2000 < L ≤ 4000	± 7

- 注 記
- 1) #印寸法は最小サービスクリアランスとする。
  - 2) 指定外の寸法公差は表 1 による。
  - 3) 取付用ネジは M12 ボルトを使用のこと。
- NOTE
1. # MINIMUM SERVICE CLEARANCE.
  2. TABLE 1 INDICATES TOLERANCE OF DIMENSIONS WHICH IS NOT SPECIFIED.
  3. USE M12 BOLTS FOR FIXING THE UNIT.

DRAWN	Aug. 2, '04	E. MIYOSHI	TITLE	RSB-103 (PM)
CHECKED		TAKAHASHI, T	名称	空中線部
APPROVED		Y. Hatai		外寸図
SCALE	1/10	表 2 参照	NAME	ANTENNA UNIT
DWG. No.	C3527-G01-B			OUTLINE DRAWING

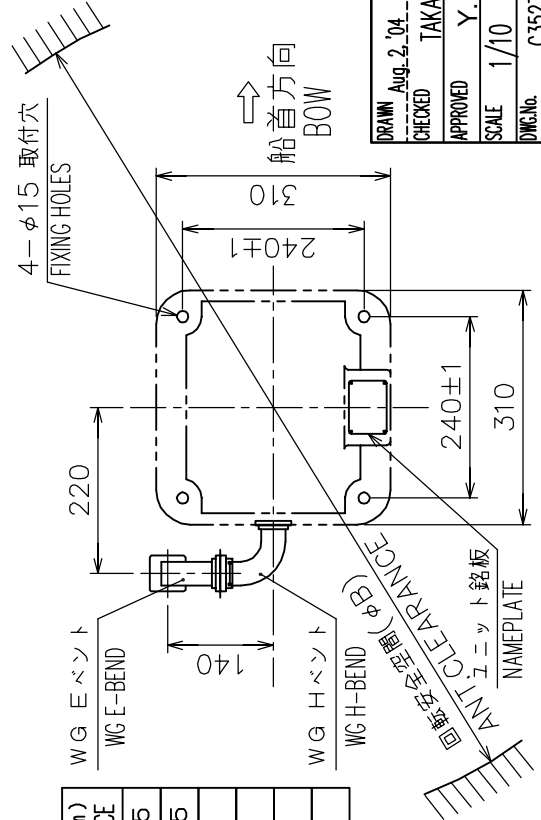
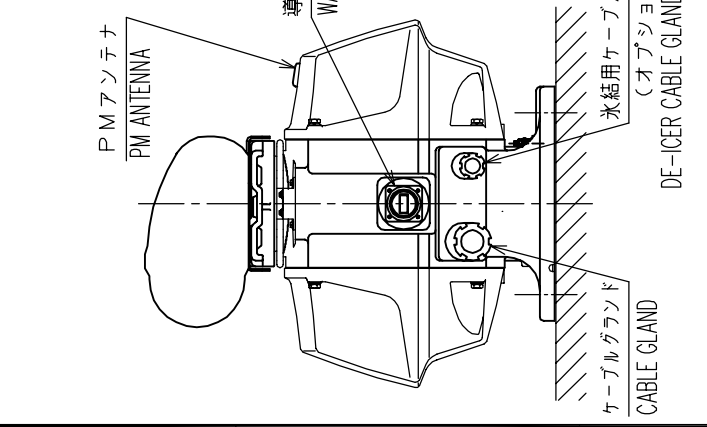
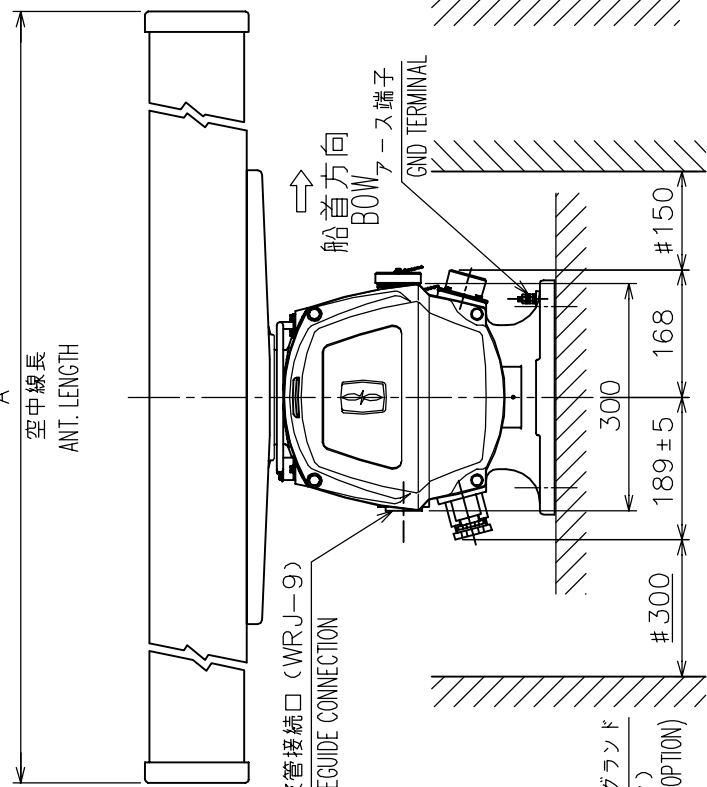
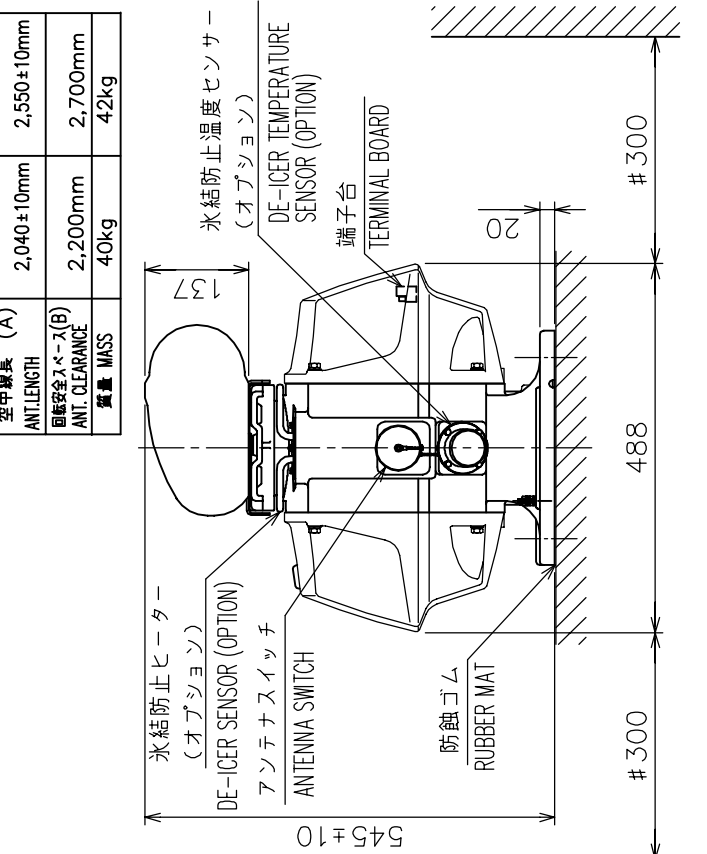
取付寸法 (矢視 E)  
FIXING DIMENSIONS (VIEW E)

表 1 TABLE 1

寸法区分 (mm) DIMENSIONS	公差 (mm) TOLERANCE
L ≤ 50	± 1.5
50 < L ≤ 100	± 2.5
100 < L ≤ 500	± 3
500 < L ≤ 1000	± 4
1000 < L ≤ 2000	± 5
2000 < L ≤ 4000	± 7

表 2 TABLE 2

アンテナ型式 ANTENNA TYPE	SN36AF	SN30AF
A: 空中線長 ANTENNA LENGTH (mm)	3765±10	3090±10
B: 回転安全空間 ANT. CLEARANCE (mm)	3860	3200
質量 MASS (kg±10%)	135	128

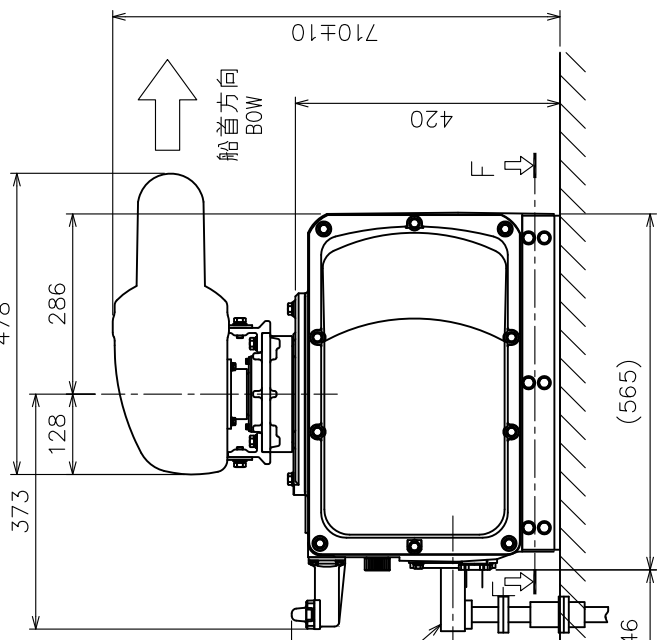
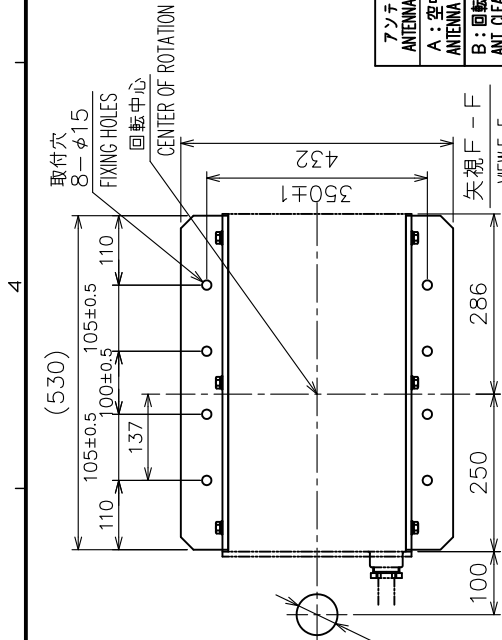

DRAWN	2/Feb/2011 T.YAMASAKI	TITLE	RSB-104/105
CHECKED	2/Feb/2011 H.MAKI	名称	空中線部 (P.M. 氷結防止付)
APPROVED	14/Feb/2011 Y.NISHIYAMA	外寸図	外寸図
SCALE	1/12 質量 表2参照 SEE TABLE 2	NAME	ANTENNA UNIT (W/PM-51, DE-ICER)
DWG.No.	C3528-G01-D		OUTLINE DRAWING

注記 1) 指定外の寸法公差は表 1 による。  
 2) # 印寸法は最小サービスクリアランスとする。  
 3) 取付用ネジは M12 ボルトを使用のこと。

NOTE 1. TABLE 1 INDICATES TOLERANCE OF DIMENSIONS WHICH IS NOT SPECIFIED.  
 2. # MINIMUM SERVICE CLEARANCE.  
 3. USE M12 BOLTS FOR FIXING THE UNIT.

表1 TABLE 1

寸法区分 (mm) DIMENSION	公差 (mm) TOLERANCE
L ≤ 50	±1.5
50 < L ≤ 100	±2.5
100 < L ≤ 500	±3

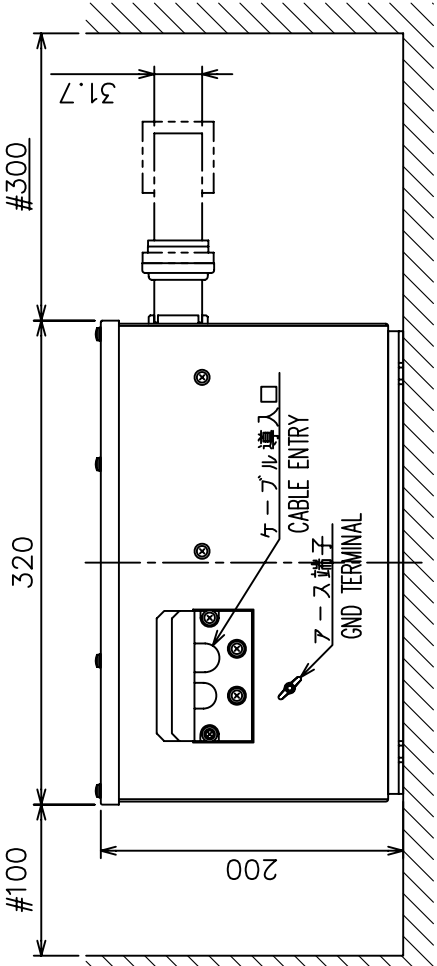
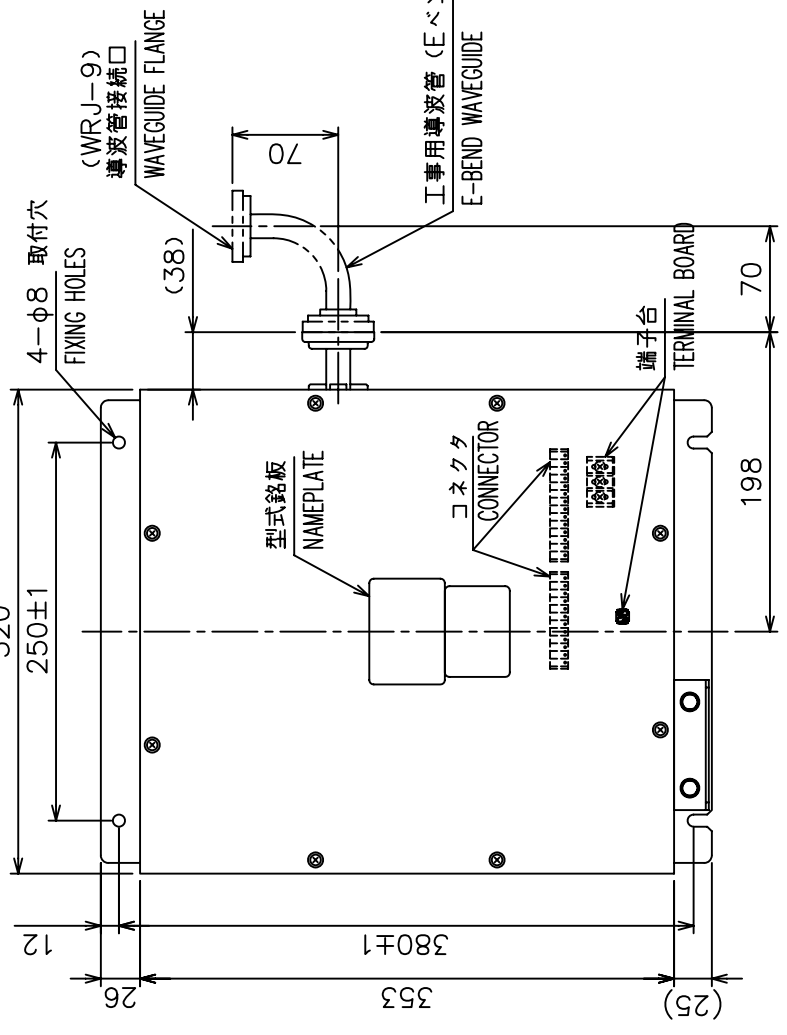
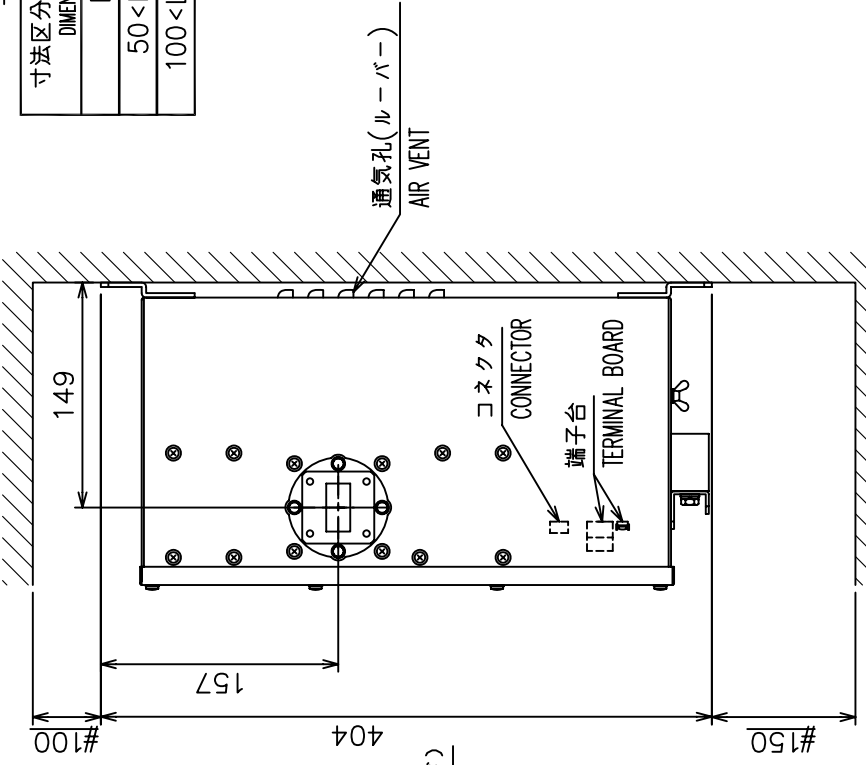

- 注記
- 1) #印寸法は最小サービスイ空間寸法とする。
  - 2) 指定外の寸法公差は表1による。
  - 3) 取付用ネジはM6ボルトまたはコーチボルト呼び径6を使用のこと。

- NOTE
1. # MINIMUM SERVICE CLEARANCE.
  2. TABLE 1 INDICATES TOLERANCE OF DIMENSIONS WHICH IS NOT SPECIFIED.
  3. USE M6 BOLTS OR  $\phi 6$  COACH SCREWS FOR FIXING THE UNIT.

DRAWN	Jan. 24 '07	T. YAMASAKI	TITLE	RTR-081
CHECKED	Jan. 24 '07	T. TAKENO	名称	送受信部
APPROVED	Jan. 24 '07	R. Esumi	外寸図	
SCALE	1/5	MASS 8.8 ±10% kg	NAME	TRANSCIVER UNIT
DWG. No.	C.5527-G07-B	REF. No.	03-154-510G-7	OUTLINE DRAWING



表 1 TABLE 1

寸法区分 (mm) DIMENSIONS	公差 (mm) TOLERANCE
$L \leq 50$	$\pm 1.5$
$50 < L \leq 100$	$\pm 2.5$
$100 < L \leq 500$	$\pm 3$
$500 < L \leq 1000$	$\pm 4$

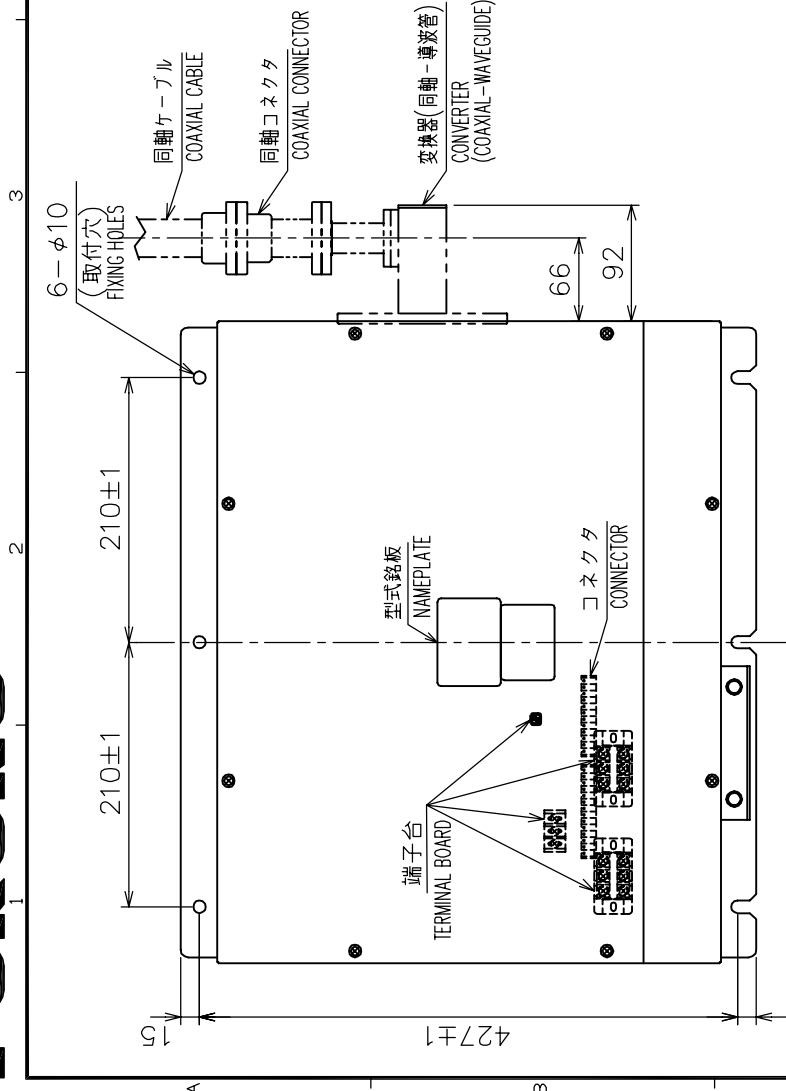
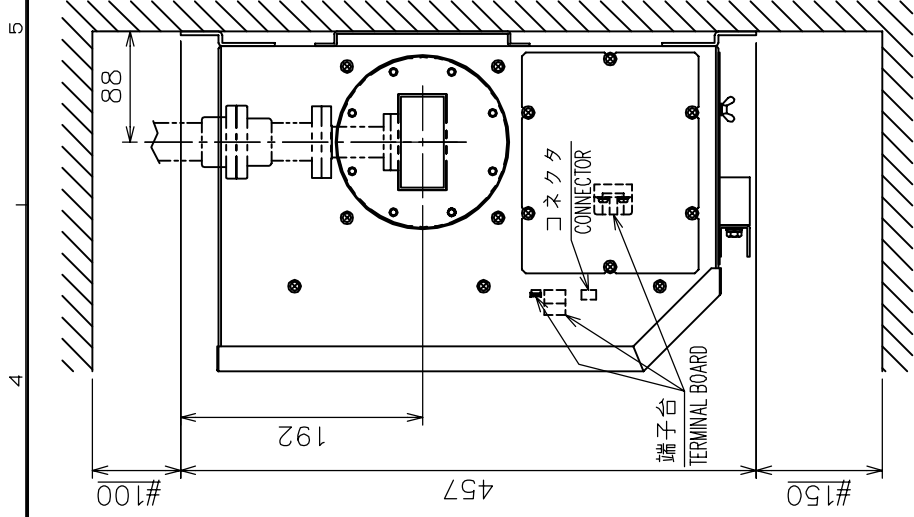

注 記  
 1) #印寸法は最小サービス空間寸法とする。  
 2) 指定外の寸法公差は表1による。  
 3) 取付用ネジはM8 ボルトまたはコーチボルト呼び径8を使用のこと。

NOTE  
 1. # MINIMUM SERVICE CLEARANCE.  
 2. TABLE 1 INDICATES TOLERANCE OF DIMENSIONS WHICH IS NOT SPECIFIED.  
 3. USE M8 BOLTS OR  $\phi 8$  COACH SCREWS FOR FIXING THE UNIT.

DRAWN	Sep. 21, '04	E. MIYOSHI	TITLE	RTR-082
CHECKED		TAKAHASHI, T	名称	送受信部
APPROVED		Y. Hatai	外寸図	
SCALE	1/6	MASS 17.0 kg	NAME	TRANSCIEVER UNIT
DWG No.	C.3528-G02-C	03-163-520G-4		OUTLINE DRAWING

表 1 TABLE 1

寸法区分 (mm) DIMENSION	公差 (mm) TOLERANCE
$L \leq 50$	$\pm 1.5$
$50 < L \leq 100$	$\pm 2.5$
$100 < L \leq 500$	$\pm 3$

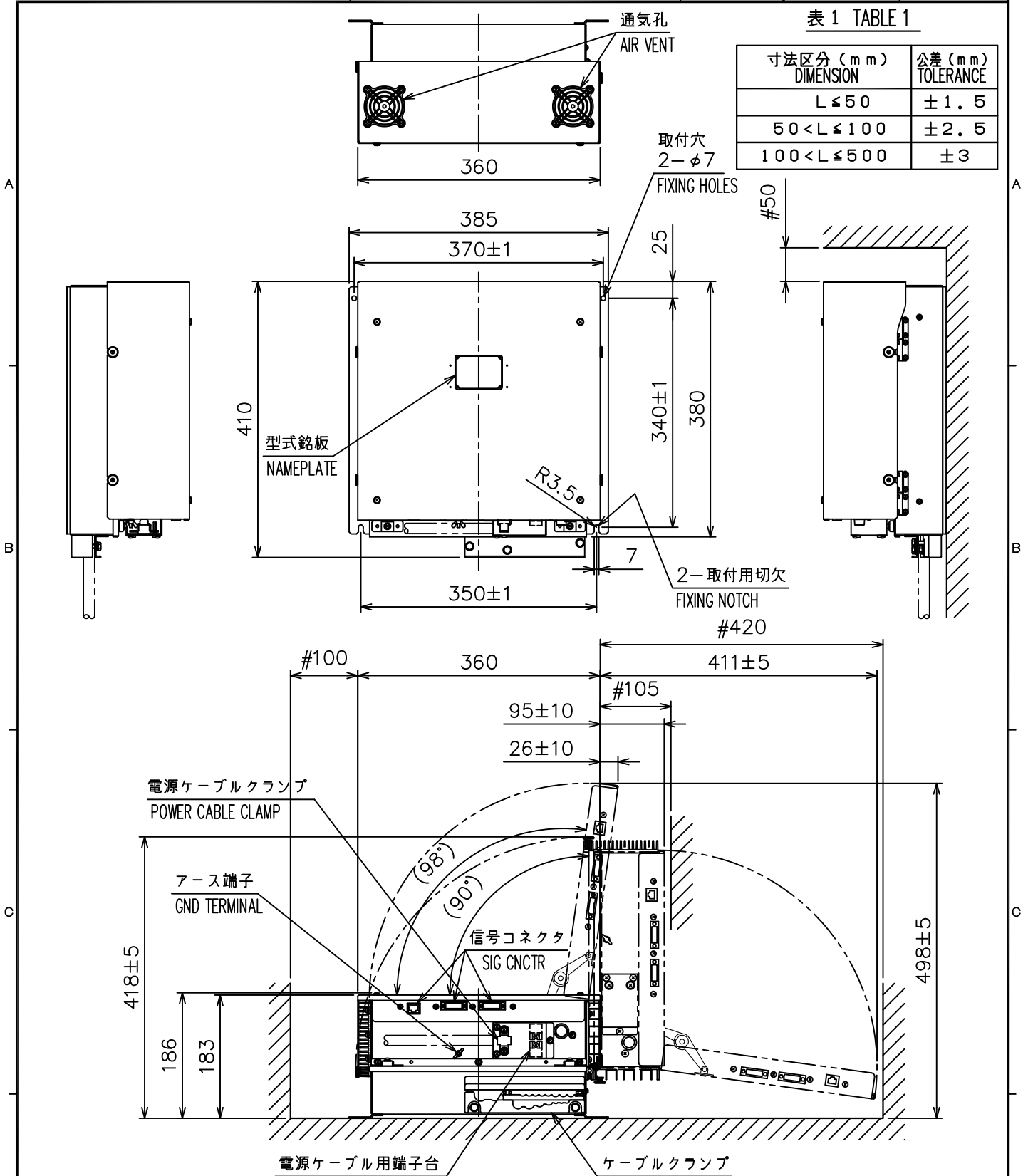

注 記

- 1) #印寸法は最小サービス空間寸法とする。
- 2) 指定外の寸法公差は表 1 による。
- 3) 取付用ネジは M6 ボルト、またはコーチボルト呼び径 6 を使用のこと。

NOTE

1. #: MINIMUM SERVICE CLEARANCE.
2. TABLE 1 INDICATES TOLERANCE OF DIMENSIONS WHICH IS NOT SPECIFIED.
3. USE M6 BOLTS OR COACH SCREWS φ6 FOR FIXING THE UNIT.

DRAWN	May 15 '07 T. YAMASAKI	TITLE	RPU-013/016
CHECKED	May 15 '07 T. TAKENO	名称	制御部
APPROVED	May 17 '07 R. Esumi		外寸図
SCALE	1/8 MASS 10 ±10% kg	NAME	PROCESSOR UNIT
DWG. No.	C3519-G03-D	REF. No.	03-163-800G-3
		OUTLINE DRAWING	

表 1 TABLE 1

寸法区分 (mm) DIMENSIONS	公差 (mm) TOLERANCE
L ≤ 50	±1.5
50 < L ≤ 100	±2.5
100 < L ≤ 500	±3
500 < L ≤ 1000	±4

矢視 A  
VIEW A

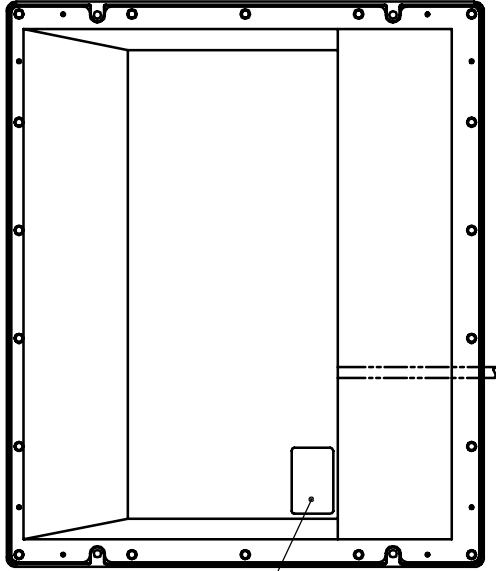

型式銘板  
NAMEPLATE

←A

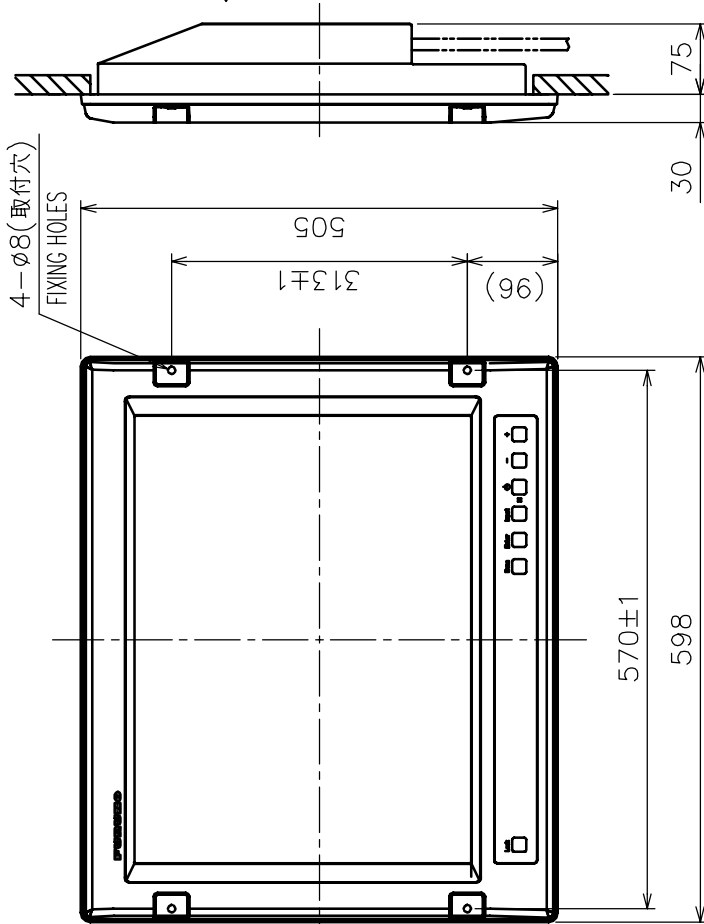

下穴位置 (4箇所)  
PILOT HOLES (4 PLACES)

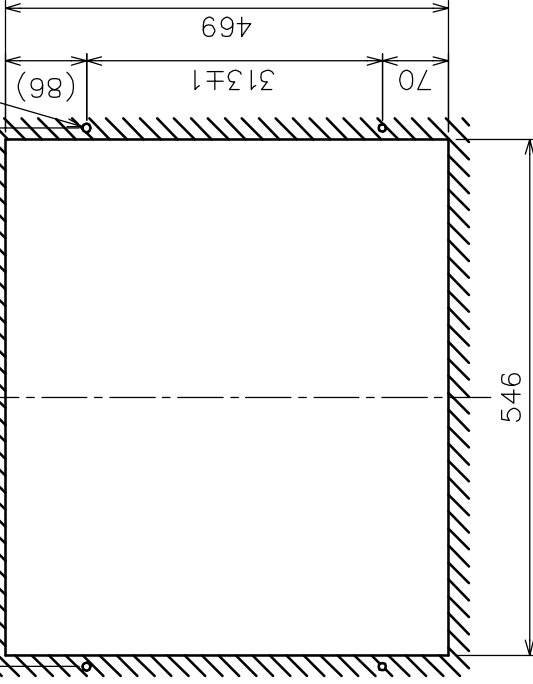

取付穴寸法図  
CUTOUT DIMENSIONS

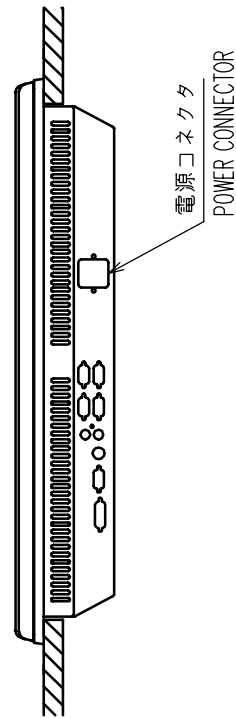

電源コネクタ  
POWER CONNECTOR

- 注 記 1) 指定外の寸法公差は表 1 による。  
 2) 取付用ネジはプラスタツピンネジ 6×30 を使用のこと。
- NOTE 1. TABLE 1 INDICATES TOLERANCE OF DIMENSIONS WHICH IS NOT SPECIFIED.  
 2. USE SELF-TAPPING SCREWS 6x30 FOR FIXING THE UNIT.

DRAWN	Jun 17, '05	E. MIYOSHI	TITLE	MU-231CE
CHECKED		TAKAHASHI, T	名称	表示部 (埋込装置)
APPROVED		Y. Hatai	外寸図	
SCALE	1/8	MASS 15 ±0.05 kg	NAME	MONITOR UNIT (FLUSH MOUNT)
DWG.No.	C4123-G02-B			OUTLINE DRAWING
				24-005-210G-0

514±3



表 1 TABLE 1

寸法区分 (mm) DIMENSIONS	公差 (mm) TOLERANCE
L ≤ 50	± 1.5
50 < L ≤ 100	± 2.5
100 < L ≤ 500	± 3
500 < L ≤ 1000	± 4

型式銘板  
NAMEPLATE

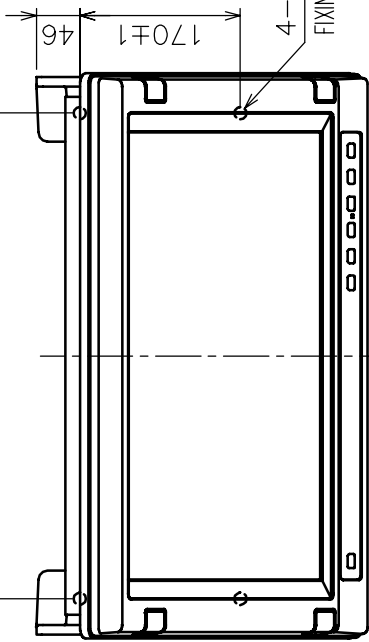
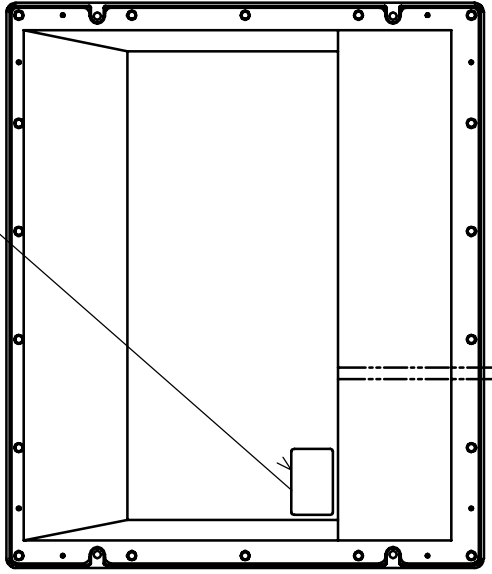

矢視 B  
VIEW B

矢視 A  
VIEW A

電源コネクタ  
POWER CONNECTOR

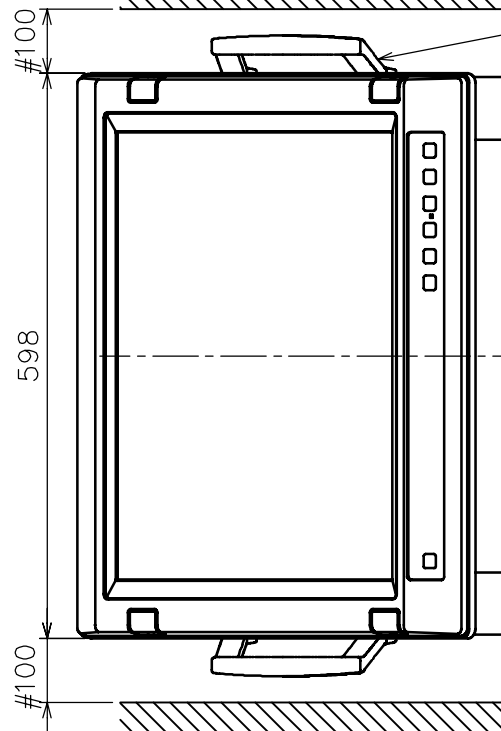
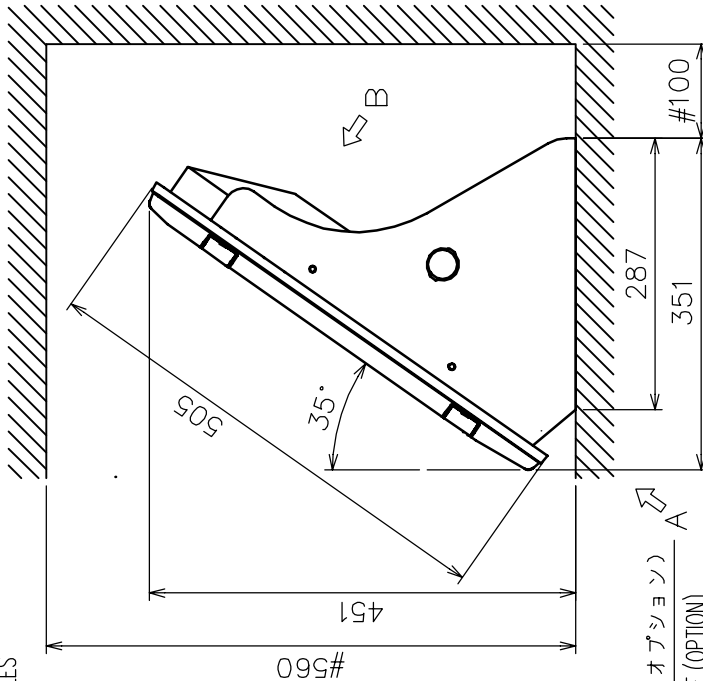

取手 (オプション)  
HANDLE (OPTION)

- 注記 1) #印寸法は最小サービスクリアランスとする。  
 2) 指定外の寸法公差は表 1 による。  
 3) 取付用ネジは M10 ボルトまたはコーチボルト呼び径 9 を使用のこと。
- NOTE 1. # MINIMUM SERVICE CLEARANCE.  
 2. TABLE 1 INDICATES TOLERANCE OF DIMENSIONS WHICH IS NOT SPECIFIED.  
 3. USE M10 BOLTS OR COACH SCREWS φ9 FOR FIXING THE UNIT.

DRAWN Jun 17, '05	E. MIYOSHI	TITLE MU-231CE
CHECKED TAKAHASHI, T	FCA-2807 series	名称 表示部 (卓上装備)
APPROVED Y. Hatate	FEA-2807	外寸図
SCALE 1/8	WASS 21 #106 kg	NAME MONITOR UNIT (TABLETOP MOUNT)
DWG.No. C4123-G03-A	24-005-230G-0	OUTLINE DRAWING

取付穴  
6-φ8  
FIXING HOLES



表1 TABLE 1

寸法区分 (mm) DIMENSION	公差 (mm) TOLERANCE
L ≤ 50	±1.5
50 < L ≤ 100	±2.5
100 < L ≤ 500	±3
500 < L ≤ 1000	±4

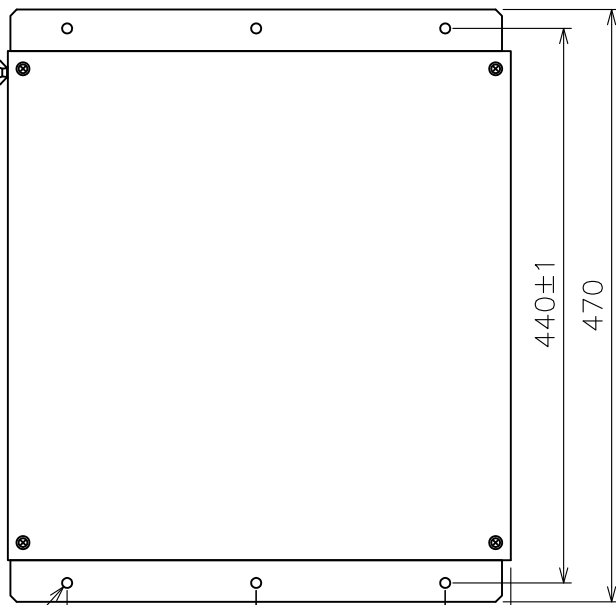
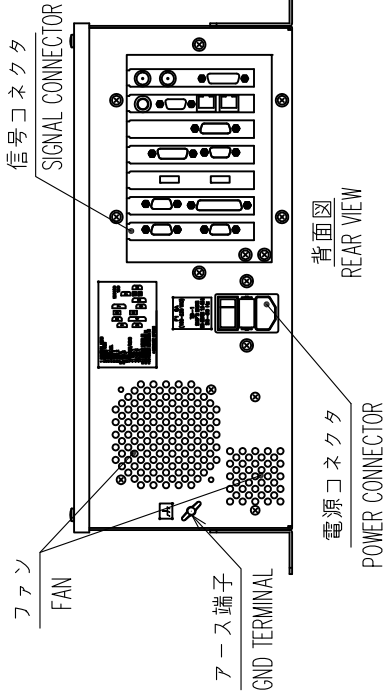

背面図  
REAR VIEW

電源コネクタ  
POWER CONNECTOR

ファン  
FAN

アース端子  
GND TERMINAL

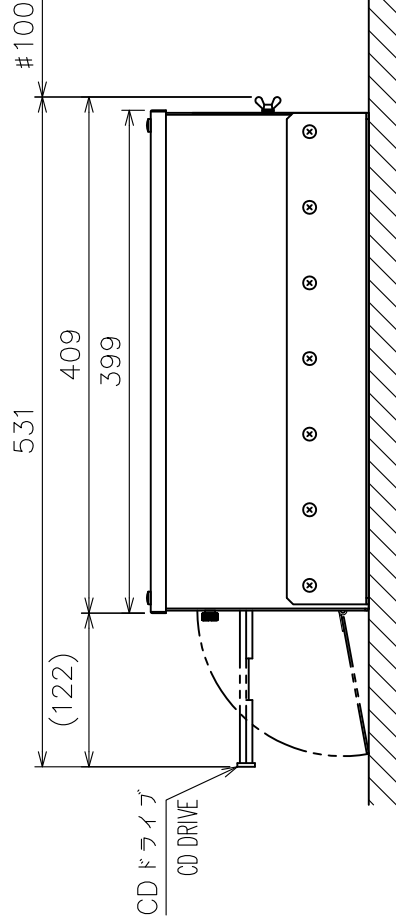

CDドライブ  
CD DRIVE

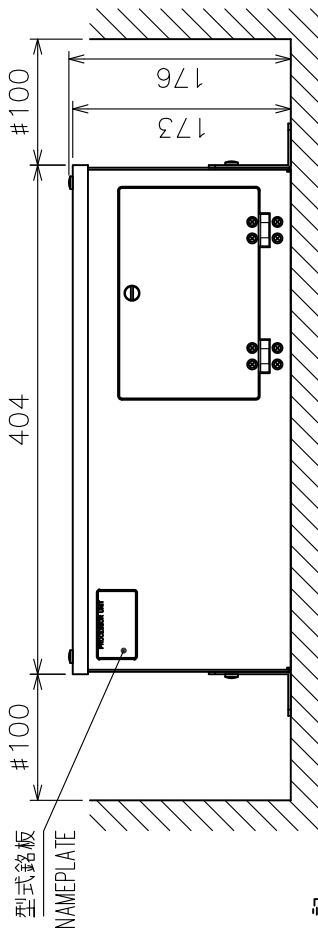

型式銘板  
NAMEPLATE

- 注記
- #1印寸法は最小サービスイタ寸法とする。
  - 指定外の寸法公差は表1による。
  - 取付用ネジはM6ボルトまたはコーナボルト呼び径φ6を使用のこと。
  - 装備ケーブアルはサービス時、本体を前方に十分引き出せるよう余裕を持たせること。
  - 装備方法は床置きのみとする。

NOTE

- MINIMUM SERVICE CLEARANCE.
- TABLE 1 INDICATES TOLERANCE OF DIMENSIONS WHICH IS NOT SPECIFIED.
- USE M6 BOLTS OR CORARCH SCREWS φ6 FOR FIXING THE UNIT.
- KEEP SUFFICIENT CABLE LENGTH BEHIND THE UNIT FOR MAINTENANCE.
- MOUNTING LOCATION IS FLOOR ONLY.

DRAWN	25/Sep/09 I.YAMASAKI	TITLE	EC-1000C
CHECKED	25/Sep/09 I.TAKENO	名称	制御部 (床置装備)
APPROVED	26/Oct/09 R.Esumi	外寸図	
SCALE	1/6	図名	PROCESSOR UNIT (FLOOR MOUNT)
DWG.No.	C4122-G01-E	REF.No.	24-005-500G-2
			OUTLINE DRAWING

表1 TABLE 1

寸法区分 (mm) DIMENSION	公差 (mm) TOLERANCE
$L \leq 50$	$\pm 1.5$
$50 < L \leq 100$	$\pm 2.5$
$100 < L \leq 500$	$\pm 3$

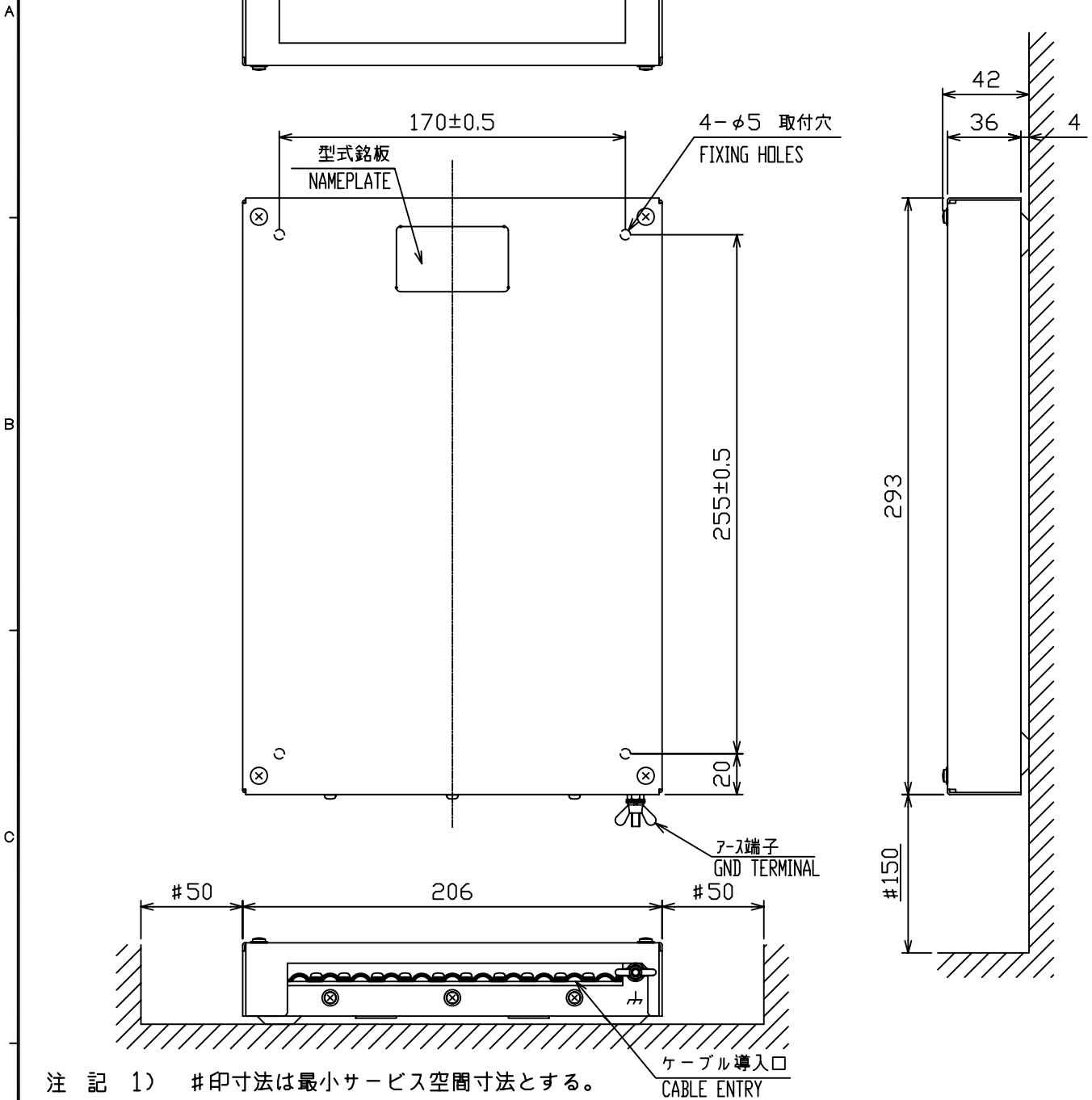

- 注記 1) #印寸法は最小サービス空間寸法とする。  
 2) 指定外の寸法公差は表1による。  
 3) 取付用ネジはトラスタッピンネジ呼び径4×20を使用のこと。

- NOTE 1. # MINIMUM SERVICE CLEARANCE.  
 2. TABLE 1 INDICATES TOLERANCE OF DIMENSIONS WHICH IS NOT SPECIFIED.  
 3. USE SELF-TAPPING SCREWS  $\phi 4 \times 20$  FOR FIXING THE UNIT.

DRAWN	Mar. 26 '07	T.YAMASAKI	TITLE	EC-1010	
CHECKED	Mar. 26 '07	T.TAKENO	名称	ECDIS LANアダプタ	
APPROVED	Mar. 28 '07	R.Esumi	FEA-2107ser.	外寸図	
SCALE	1/3	MASS	1.8 ±10% kg	NAME	ECDIS LAN ADAPTER
DWG No.	C4122-G02- C		REF. No.	24-005-300G-2	OUTLINE DRAWING

表 1 TABLE 1

寸法区分 (mm) DIMENSION	公差 (mm) TOLERANCE
L ≤ 50	±1.5
50 < L ≤ 100	±2.5
100 < L ≤ 500	±3

制御部用  
TO CONTROL UNIT

リモート操作部用 (オプション)  
TO REMOTE CONTROL (OPTION)

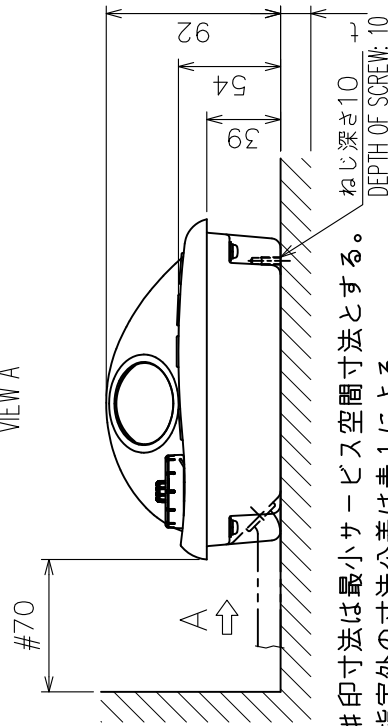
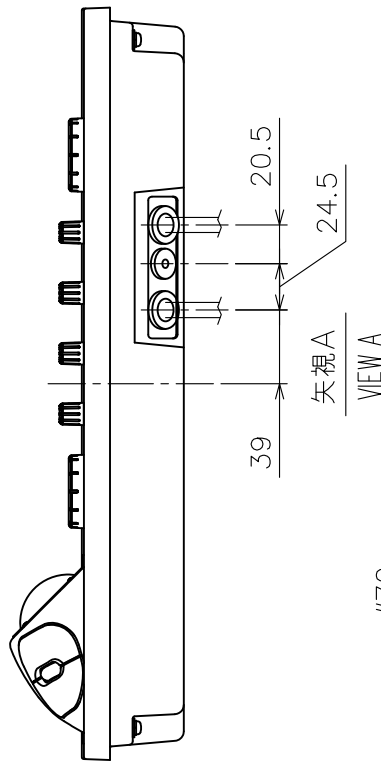
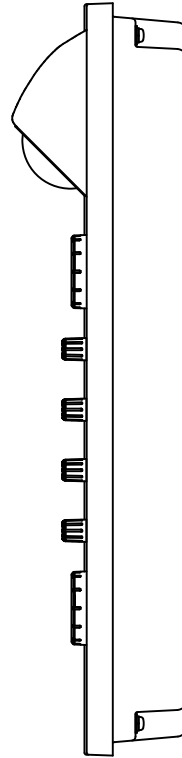
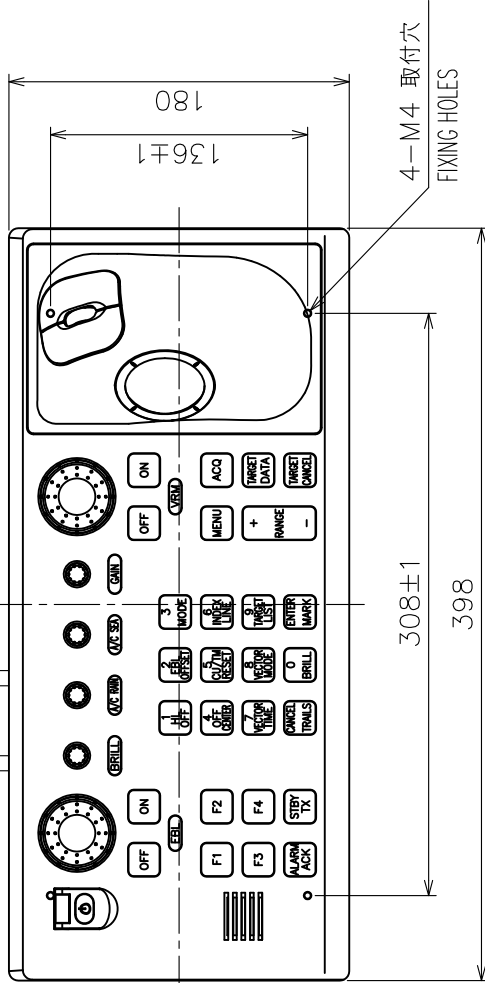

- 注 記
- 1) # 印寸法は最小サービス空間寸法とする。
  - 2) 指定外の寸法公差は表 1 による。
  - 3) 取付用ネジはセムスB (M4X12) を使用のこと。  
取付面板厚 (t) は  $2 \leq t \leq 4$  とする。それ以外は、  
ネジ長さを  $(t + 7.8) \pm 2$  とする。

- NOTE
1. # MINIMUM SERVICE CLEARANCE.
  2. TABLE 1 INDICATES TOLERANCE OF DIMENSIONS WHICH IS NOT SPECIFIED.
  3. USE M4x12 SCREWS FOR FIXING THE UNIT.  
THICKNESS OF MOUNTING BOARD(t) SHOULD BE  $2 \leq t \leq 4$ .  
FOR THICKER ONE USE SCREW LENGTH:  $(t+7.8) \pm 2$ .

DRAWN	Jun. 11 '08	T. YAMASAKI	TITLE	RCU-014/020
CHECKED	Jun. 11 '08	T. TAKENO	名称	操作部
APPROVED	Jan. 18 '08	R. Esumi	外寸図	
SCALE	1/4	質量 3.7 kg	NAME	CONTROL UNIT
DWG.No.	C3519-G06-E	03-163-750G-4		OUTLINE DRAWING

表 1 TABLE 1

寸法区分 (mm) DIMENSION	公差 (mm) TOLERANCE
L ≤ 50	± 1.5
50 < L ≤ 100	± 2.5
100 < L ≤ 500	± 3

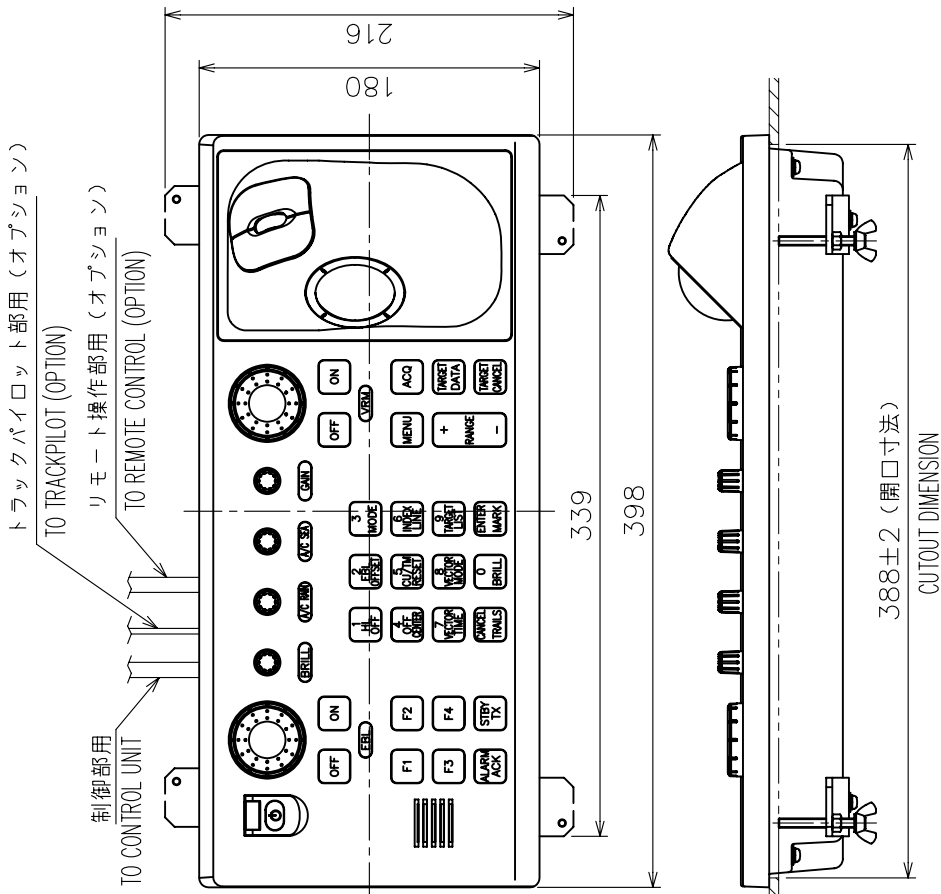
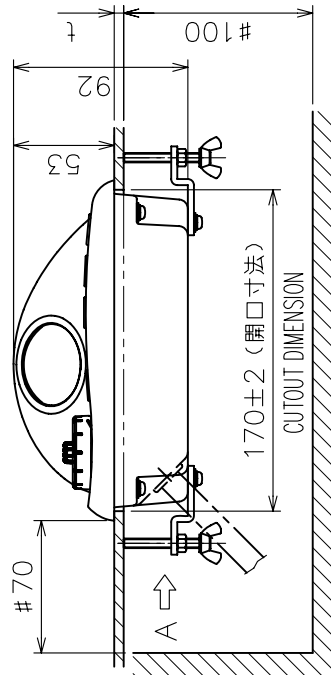
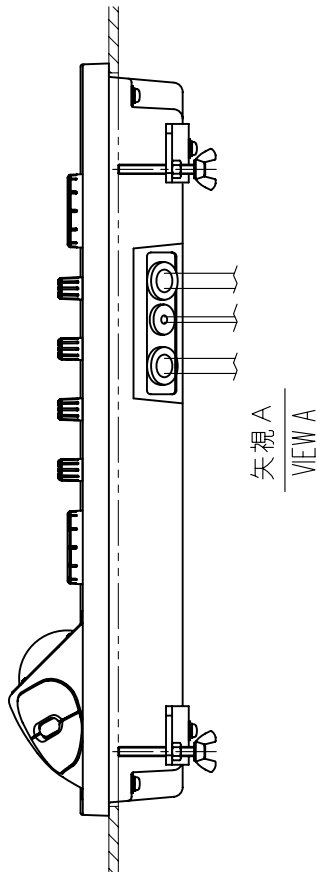

- 注記 1) #印寸法は最小サービス空間寸法とする。  
 2) 指定外の寸法公差は表1による。  
 3) 取付面板厚 (t) は最大20とする。
- NOTE 1. # MINIMUM SERVICE CLEARANCE.  
 2. TABLE 1 INDICATES TOLERANCE OF DIMENSIONS WHICH IS NOT SPECIFIED.  
 3. THICKNESS OF MOUNTING BOARD(t) SHOULD BE MAX. 20.

DRAWN	Apr. 19 '07	T. YAMASAKI	TITLE	RCU-014/020
CHECKED	Apr. 19 '07	I. TAKENO	名称	操作部 (埋込装備)
APPROVED	Apr. 23 '07	R. Esumi	外寸図	
SCALE	1/4	質量 3.8 kg	NAME	CONTROL UNIT (FLUSH MOUNT)
DWG.No.	C3524-G04-D	03-163-751G-3	OUTLINE DRAWING	



表 1 TABLE 1

寸法区分 (mm) DIMENSION	公差 (mm) TOLERANCE
L ≤ 50	± 1.5
50 < L ≤ 100	± 2.5
100 < L ≤ 500	± 3

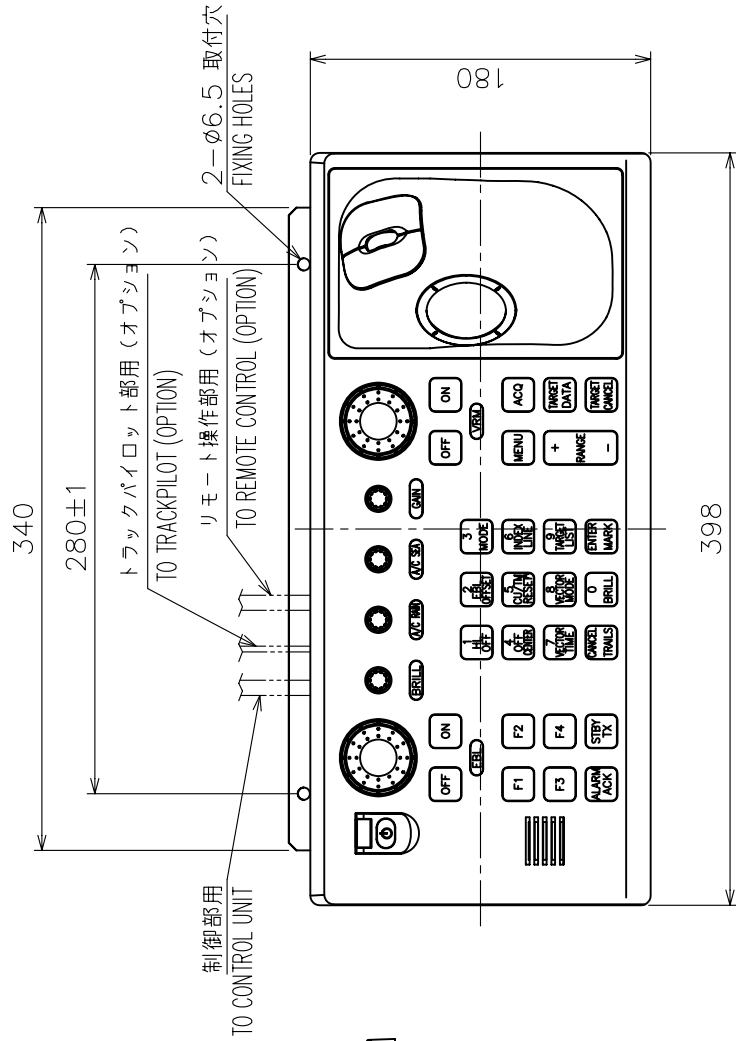
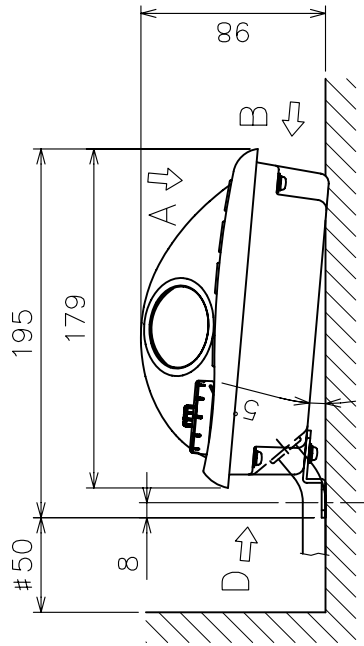
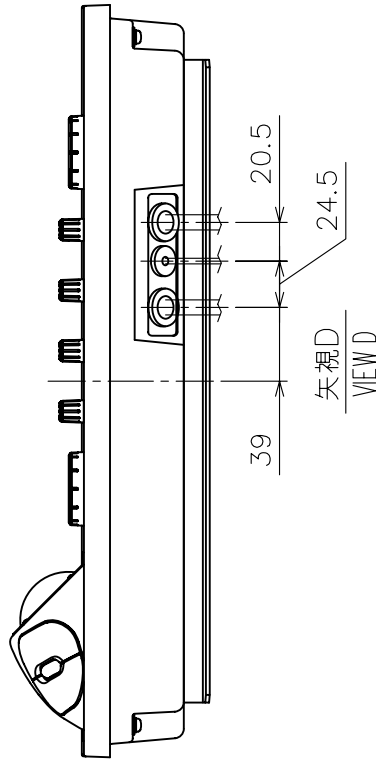

矢視A  
VIEW A

矢視B  
VIEW B

DRAWN	Apr. 19 '07 T. YAMASAKI	TITLE	RCU-014/020
CHECKED	Apr. 19 '07 T. TAKENO	名称	操作部 (直付金具装備)
APPROVED	Apr. 23 '07 R. Esumi	外寸図	
SCALE	1/4	質量は0.7kgを含有 質量は0.7kgを含有 MASS INCLUDES 0.7kg	CONTROL UNIT (TABLETOP MOUNT W/ KB PLATE)
DWG. No.	C3524-605-C		OUTLINE DRAWING

- 注 記 1) #印寸法は最小サービス空間寸法とする。  
 2) 指定外の寸法公差は表 1 による。  
 3) 取付用ネジはトラスタップピンネジ呼び径6、またはM6 ボルトを使用のこと。
- NOTE 1. # MINIMUM SERVICE CLEARANCE.  
 2. TABLE 1 INDICATES TOLERANCE OF DIMENSIONS WHICH IS NOT SPECIFIED.  
 3. USE TAPPING SCREW Ø6 OR M6 BOLTS FOR FIXING THE UNIT.

表 1 TABLE 1

寸法区分 (mm) DIMENSION	公差 (mm) TOLERANCE
L ≤ 50	± 1.5
50 < L ≤ 100	± 2.5
100 < L ≤ 500	± 3

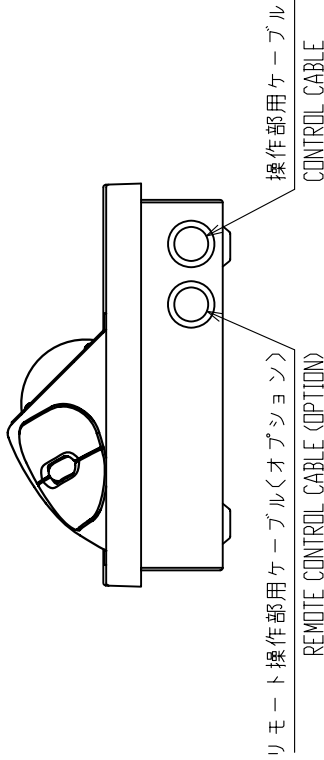
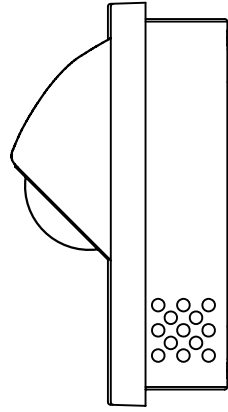
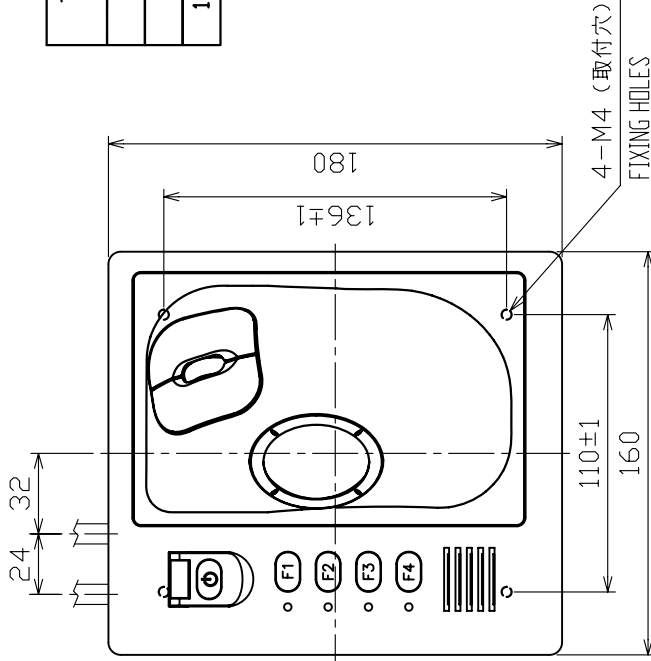

矢視A  
VIEW A

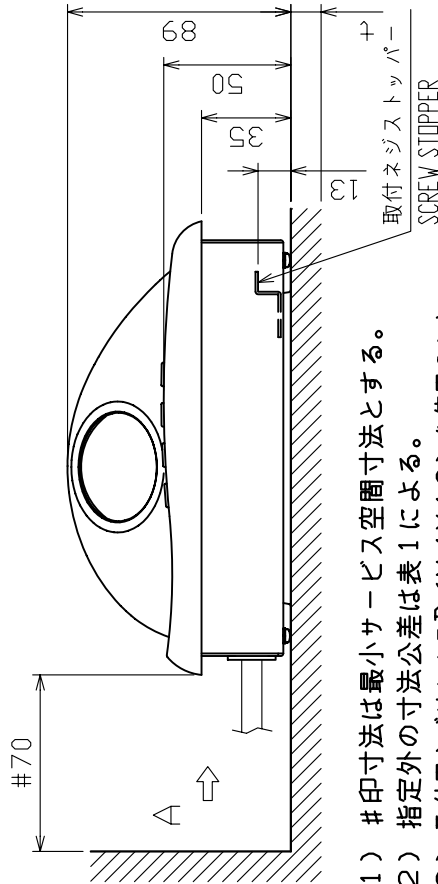

- 注 記
- 1) #印寸法は最小サービス空間寸法とする。
  - 2) 指定外の寸法公差は表1による。
  - 3) 取付用ネジはセムスB (M4×12) を使用のこと。  
取付面板厚(七)は2 ≤ 七 ≤ 5とする。それ以外は、  
ネジ長さを (七 + 7.8) ± 2とする。

- NOTE
1. # MINIMUM SERVICE CLEARANCE.
  2. TABLE 1 INDICATES TOLERANCE OF DIMENSIONS WHICH IS NOT SPECIFIED.
  3. USE M4x12 SCREWS FOR FIXING THE UNIT.  
THICKNESS OF MOUNTING BEARD(七) SHOULD BE 2 ≤ 七 ≤ 5.  
FOR THICKER ONE USE SCREW LENGTH: (七+7.8) ± 2.

DRAWN	Apr. 17 '07	T. YAMASAKI	TITLE	RCU-015/015FEA
CHECKED	Apr. 17 '07	T. TAKENO	名称	操作部 (卓上装備)
APPROVED	Apr. 23 '07	R. Esumi	外寸図	
SCALE	1/3	質量 2.4 kg 質量中心位置を記す。	NAME	CONTROL UNIT (DESKTOP MOUNT)
DWG. No.	C3519-G13-C	REF. No.	03-163-785G-2	OUTLINE DRAWING

表 1 TABLE 1

寸法区分 (mm) DIMENSION	公差 (mm) TOLERANCE
$L \leq 50$	$\pm 1.5$
$50 < L \leq 100$	$\pm 2.5$
$100 < L \leq 500$	$\pm 3$

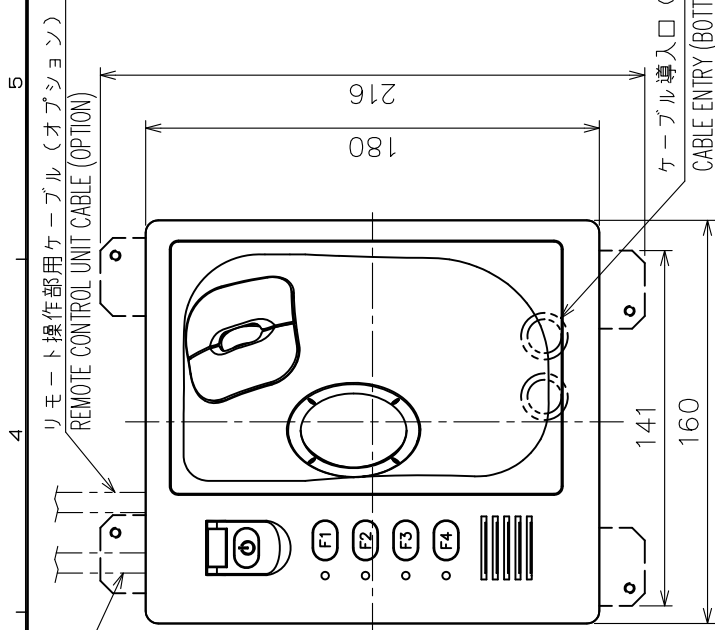
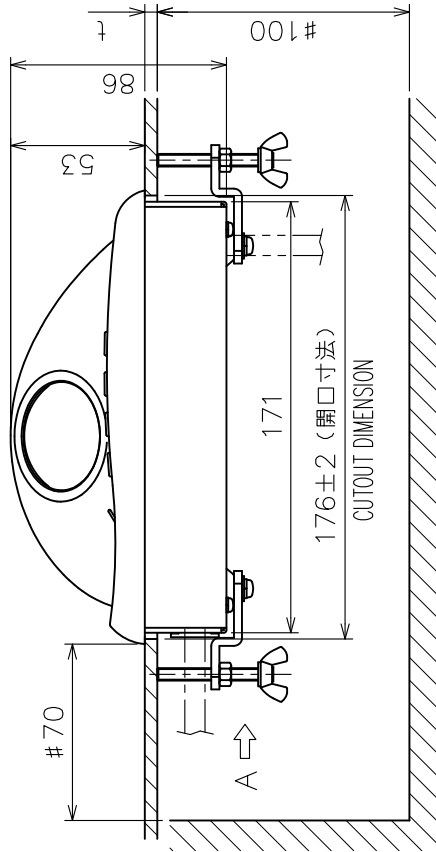
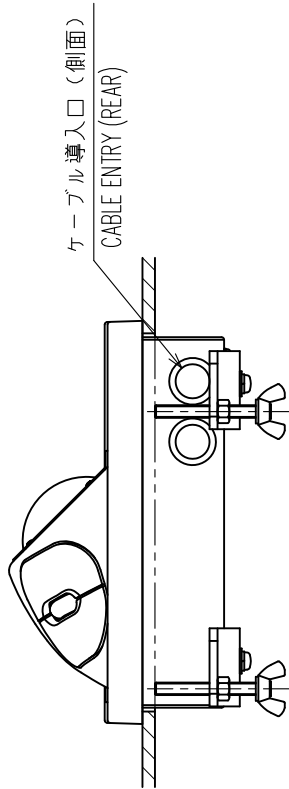

注 記

- 1) #印寸法は最小サービス空間寸法とする。
- 2) 指定外の寸法公差は表1による。
- 3) ケーブル導入口は側面・底面から選択のこと。
- 4) 取付面板厚 (t) は最大10とする

NOTE

1. # MINIMUM SERVICE CLEARANCE.
2. TABLE 1 INDICATES TOLERANCE OF DIMENSIONS WHICH IS NOT SPECIFIED.
3. SELECT CABLE ENTRY FROM REAR OR SIDE.
4. THICKNESS OF MOUNTING BOARD (t) SHOULD BE MAX. 10.

DRAWN	Apr. 19 '07	I. YAMASAKI	TITLE	RCU-015/015FEA
CHECKED	Apr. 19 '07	T. TAKENO	名称	操作部 (埋込装備)
APPROVED	Apr. 23 '07	R. Esumi	外寸図	
SCALE	1/3	質量 2.5 kg	NAME	CONTROL UNIT (FLUSH MOUNT)
DMG.No.	C3519-G14-D	質量(10mケーブルを含む) MASS INCLUDES 10m CABLE	OUTLINE DRAWING	
				03-163-786G-2

表 1 TABLE 1

寸法区分 (mm) DIMENSION	公差 (mm) TOLERANCE
L ≤ 50	± 1.5
50 < L ≤ 100	± 2.5
100 < L ≤ 500	± 3

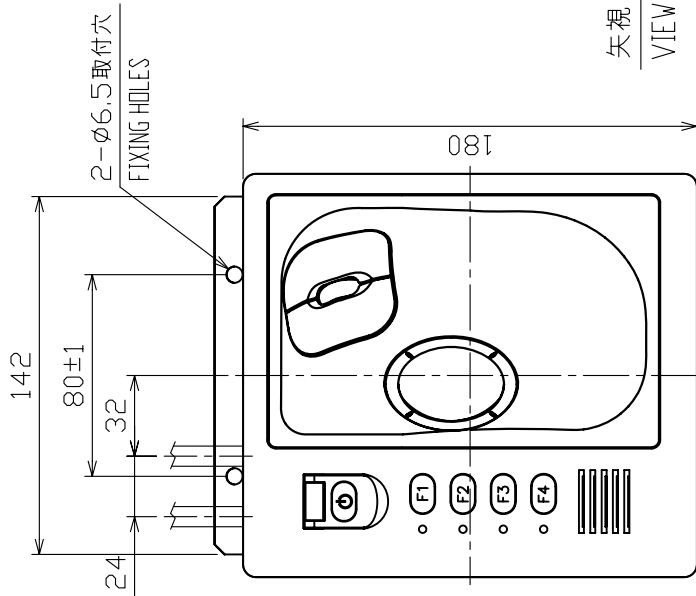

矢視A  
VIEW A

矢視B  
VIEW B

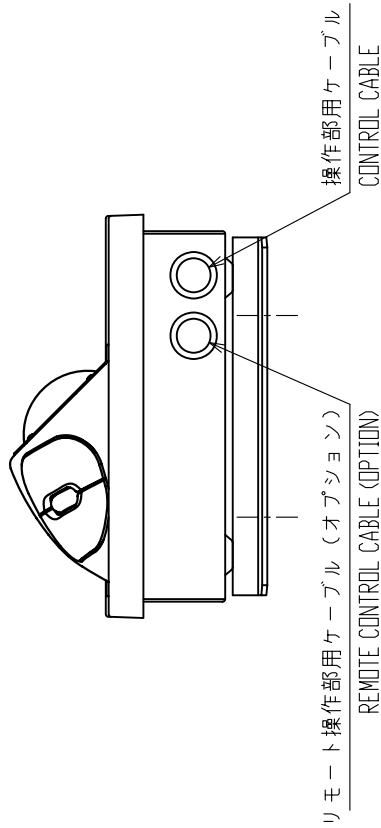
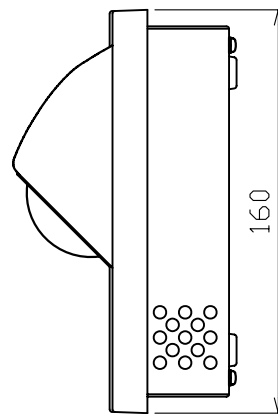

矢視D  
VIEW D

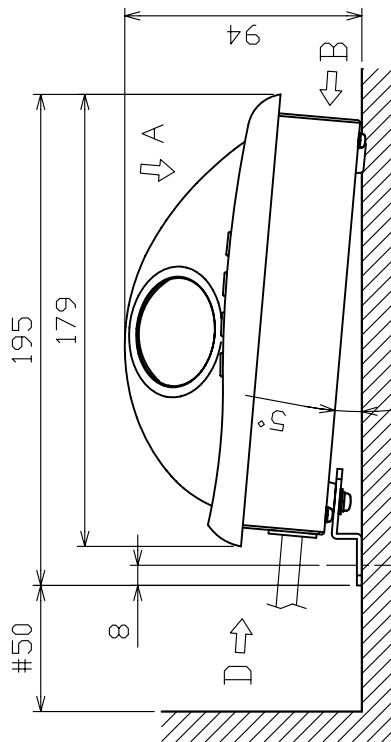

注 記

- 1) #印寸法は最小サービス空間寸法とする。
- 2) 指定外の寸法公差は表 1 による。
- 3) 取付にはトラスタップピンネジ呼び径6またはM6 ボルトを使用のこと。

NOTE

1. #: MINIMUM SERVICE CLEARANCE.
2. TABLE 1 INDICATES TOLERANCE OF DIMENSIONS WHICH IS NOT SPECIFIED.
3. USE TAPPING SCREWS #6 OR M6 BOLTS FOR FIXING THE UNIT.

DRAWN	Apr. 19 '07	T. YAMASAKI	TITLE	RCU-015/015FEA
CHECKED	Apr. 19 '07	T. TAKENO	名称	操作部 (取付金具装備)
APPROVED	Apr. 23 '07	R. Esumi	外寸図	
SCALE	1/3	MASS 2.5 kg	NAME	CONTROL UNIT (TABLETOP MOUNT W/ FIXTURE)
DWG No.	C3519-G15-C	03-163-787G-1		OUTLINE DRAWING

表 1 TABLE 1

寸法区分 (mm) DIMENSIONS	公差 (mm) TOLERANCE
L ≤ 50	± 1.5
50 < L ≤ 100	± 2.5
100 < L ≤ 500	± 3

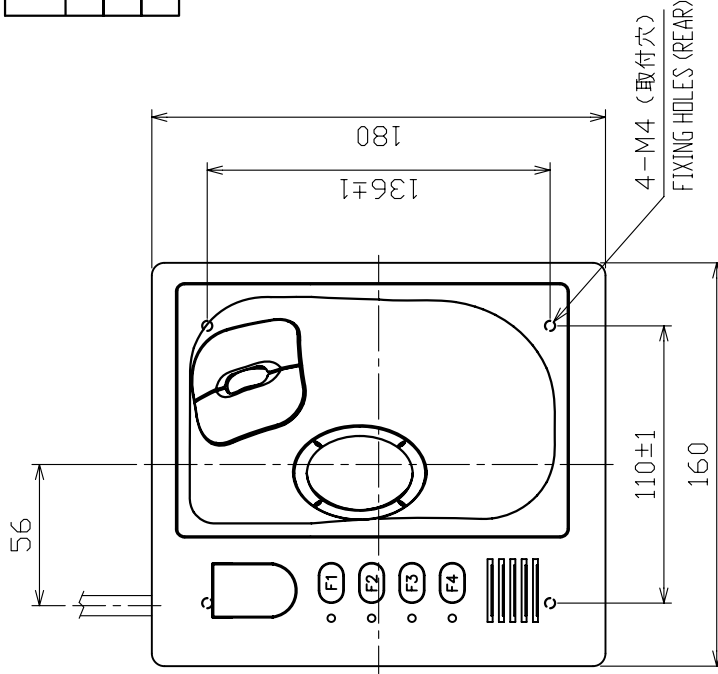

NOTE

1. # MINIMUM SERVICE CLEARANCE.
2. TABLE 1 INDICATES TOLERANCE OF DIMENSIONS WHICH IS NOT SPECIFIED.
3. USE M4X12 SCREWS FOR FIXING. THICKNESS OF MOUNTING BOARD SHOULD BE  $2 \leq t \leq 5$ . FOR USING GREATER THICKNESS, USE SCREW WHOSE LENGTH IS  $(t+7.8) \pm 2$ .

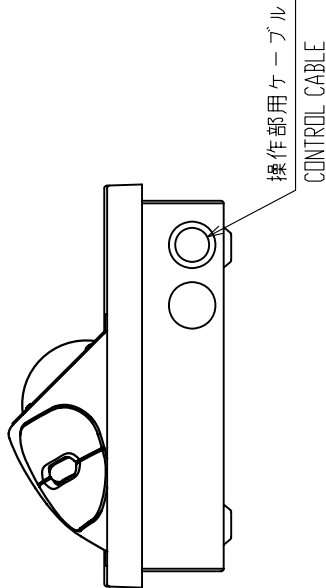
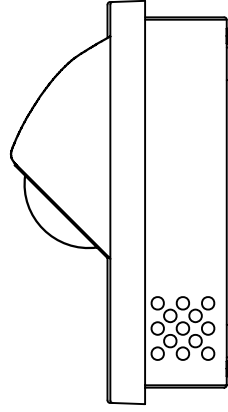

矢視A  
VIEW A

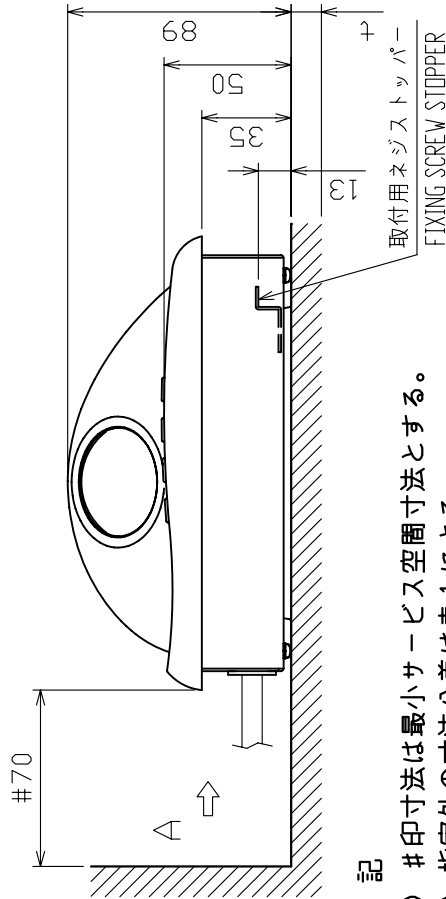

- 注 記
- 1) # 印寸法は最小サービス空間寸法とする。
  - 2) 指定外の寸法公差は表 1 による。
  - 3) 取付用ネジはセムスB (M4X12) を使用のこと。  
取付面板厚(t)は  $2 \leq t \leq 5$  とする。  
それ以外はネジ長さ  $(t+7.8) \pm 2$  のセムスBを使用のこと。

DRAWN	Feb. 7 '07	E. MIYOSHI	TITLE	RCU-016
CHECKED		TAKAHASHI, T	名称	操作部 (卓上装備)
APPROVED		Y. Hatai	外寸図	
SCALE	1/3	質量 2.4 kg 寸法 10ヶ所 質量 V 10m CABLE	NAME	CONTROL UNIT (DESKTOP MOUNT)
DWG. No.	C3519-G16-C	03-163-780G-4		OUTLINE DRAWING

表 1 TABLE 1

寸法区分 (mm) DIMENSIONS	公差 (mm) TOLERANCE
L ≤ 50	± 1.5
50 < L ≤ 100	± 2.5
100 < L ≤ 500	± 3

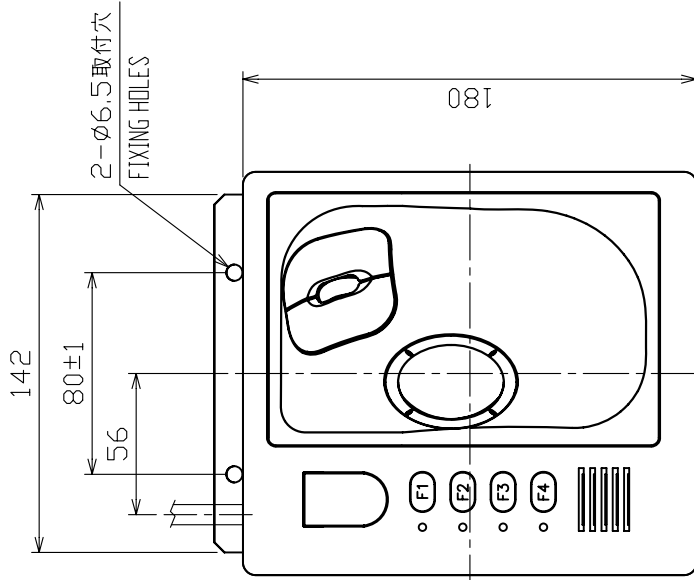

矢視 A  
VIEW A

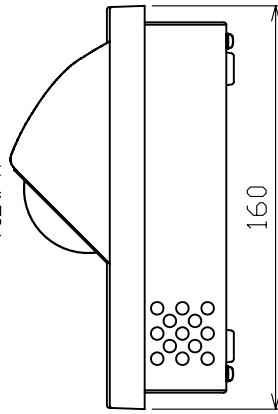

矢視 B  
VIEW B

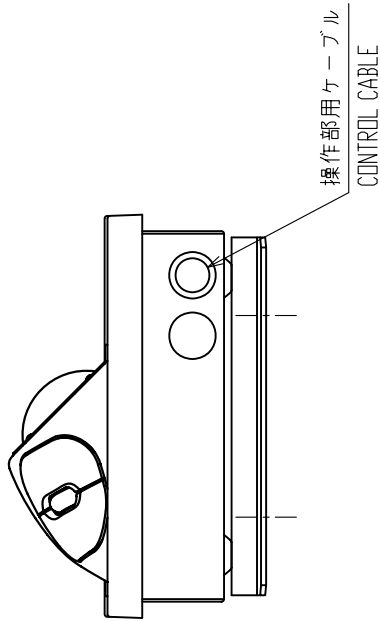

矢視 D  
VIEW D

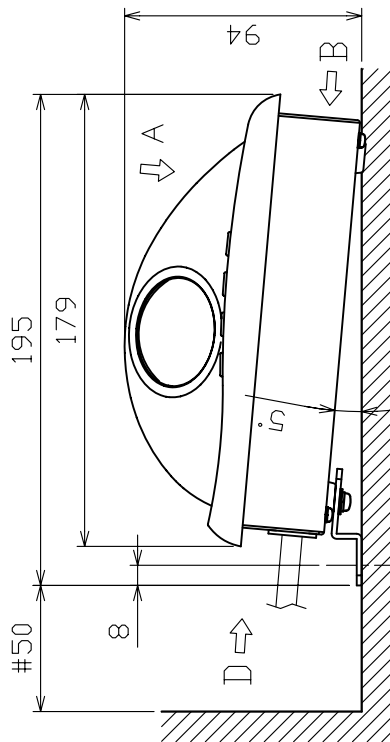

注 記

- 1) #印寸法は最小サービスクリアランスとする。
- 2) 指定外の寸法公差は表 1 による。
- 3) 取付用ネジはトラスクピピンネジ呼び径6、またはM6ボルトを使用のこと。

NOTE

1. #: MINIMUM SERVICE CLEARANCE.
2. TABLE 1 INDICATES TOLERANCE OF DIMENSIONS, WHICH IS NOT SPECIFIED.
3. USE TAPPING SCREWS #6 OR M6 BOLTS FOR FIXING THE UNIT.

DRAWN	Feb. 5 '07	E. MIYOSHI	TITLE	RCU-016
CHECKED		TAKAHASHI, T	名称	操作部 (取付金具装備)
APPROVED		Y. Ho, tai	外寸図	
SCALE	1/3	100% 質量100%寸法を基に MASS W/ 100% CABLE	NAME	CONTROL UNIT (TABLETOP MOUNT W/ FIXTURE)
FIG.No.	C3519-G12-C	03-163-782G-2		OUTLINE DRAWING

表 1 TABLE 1

寸法区分 (mm) DIMENSIONS	公差 (mm) TOLERANCE
$L \leq 50$	$\pm 1.5$
$50 < L \leq 100$	$\pm 2.5$
$100 < L \leq 500$	$\pm 3$

操作部用ケーブル  
CONTROL UNIT CABLE

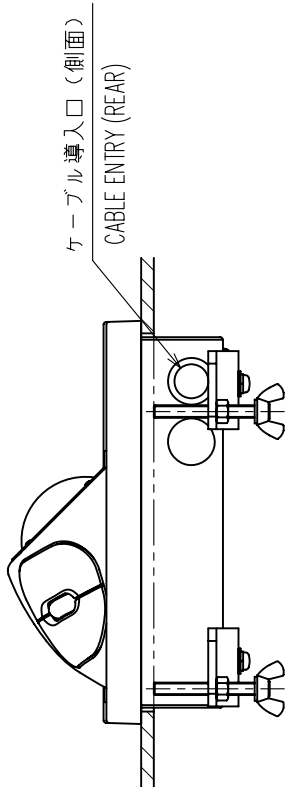

矢視 A  
VIEW A

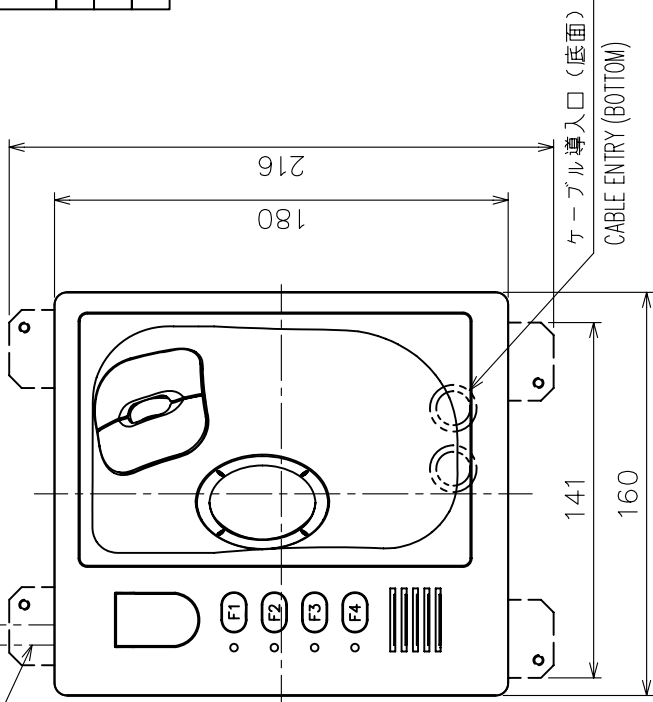
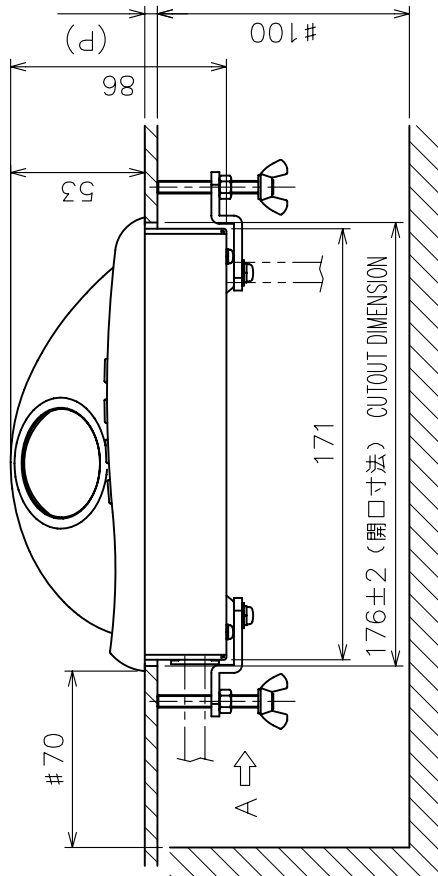

注 記

- 1) # 印寸法は最小サービス空間寸法とする。
- 2) 指定外の寸法公差は表 1 による。
- 3) ケーブル導入口は側面・底面から選択のこと。
- 4) 壁の厚さ (P) は最大 10 とする

NOTE

1. # MINIMUM SERVICE CLEARANCE.
2. TABLE 1 INDICATES TOLERANCE OF DIMENSIONS WHICH IS NOT SPECIFIED.
3. SELECT CABLE ENTRY FROM REAR OR SIDE.
4. THICKNESS (P): 10 mm MAX.

DRAWN	Feb. 6 '07.	E. MIYOSHI	TITLE	RCU-016
CHECKED		TAKAHASHI, T	名称	操作部 (埋込装備)
APPROVED		Y. Hotoi	外寸図	
SCALE	1/3	MASS ±10% FAR-2117 SER. ケーブル厚さを含む。 MASS W/ 10m. CABLE	NAME	CONTROL UNIT (FLUSH MOUNT)
DMG.No.	C3519-G11-D	03-163-781C-4	OUTLINE DRAWING	

表1 TABLE 1

寸法区分 (mm) DIMENSION	公差 (mm) TOLERANCE
$L \leq 50$	$\pm 1.5$
$50 < L \leq 100$	$\pm 2.5$
$100 < L \leq 500$	$\pm 3$

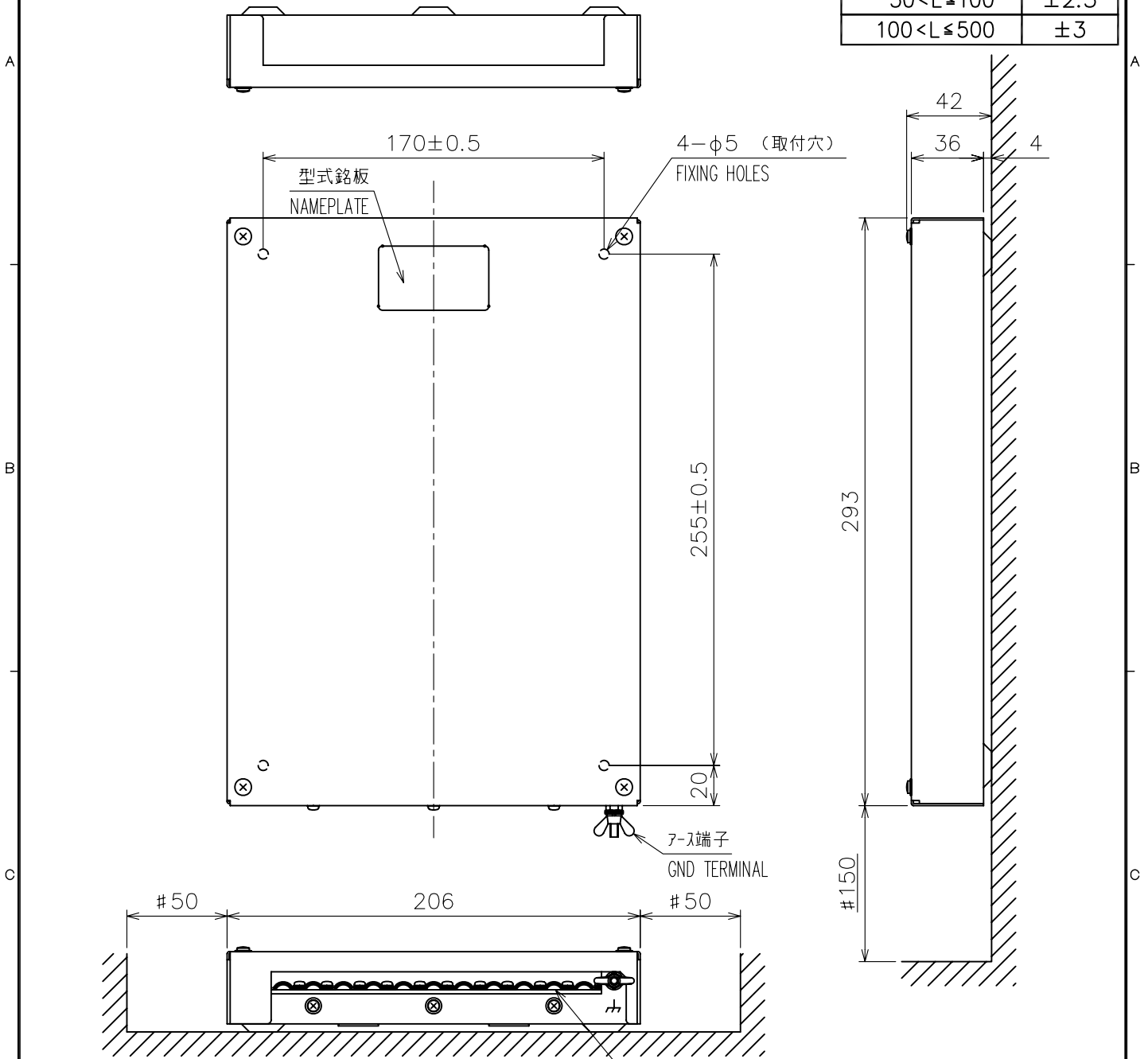

- 注記 1) #印寸法は最小サービス空間寸法とする。  
 2) 指定外の寸法公差は表1による。  
 3) 取付用ネジはトラスタッピンネジ呼び径 $4 \times 20$ を使用のこと。

- NOTE 1. #: MINIMUM SERVICE CLEARANCE.  
 2. TABLE 1 INDICATES TOLERANCE OF DIMENSIONS WHICH IS NOT SPECIFIED.  
 3. USE SELF-TAPPING SCREWS  $\phi 4 \times 20$  FOR FIXING THE UNIT.

DRAWN	Mar. 26 '07 T.YAMASAKI	TITLE	EC-1020
CHECKED	Mar. 26 '07 T.TAKENO	名称	ECDIS Bアダプタ
APPROVED	Mar. 28 '07 R.Esumi	FEA-2105/2107ser.	外寸図
SCALE	1/3	MASS	1.9 $\pm 10\%$ kg
DWG.No.	C4120-G06-C	REF.No.	24-005-310G-2
		NAME	ECDIS B-ADAPTER
			OUTLINE DRAWING



表 1 TABLE 1

寸法区分 (mm) DIMENSIONS	公差 (mm) TOLERANCE
$L \leq 50$	$\pm 1.5$
$50 < L \leq 100$	$\pm 2.5$
$100 < L \leq 500$	$\pm 3$

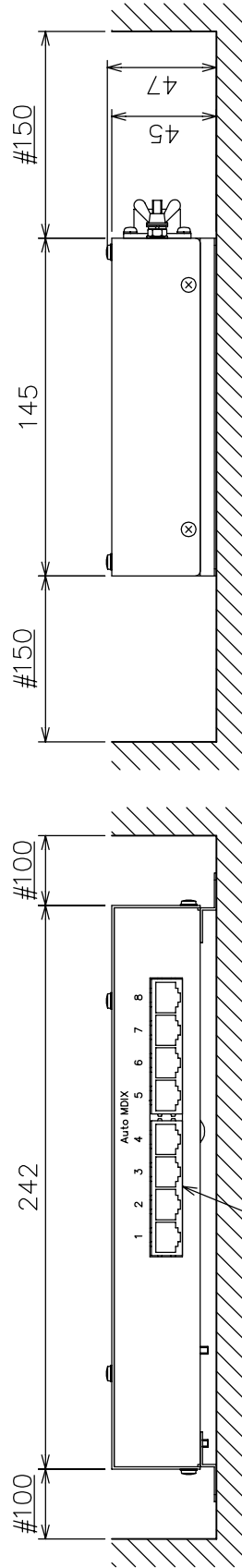
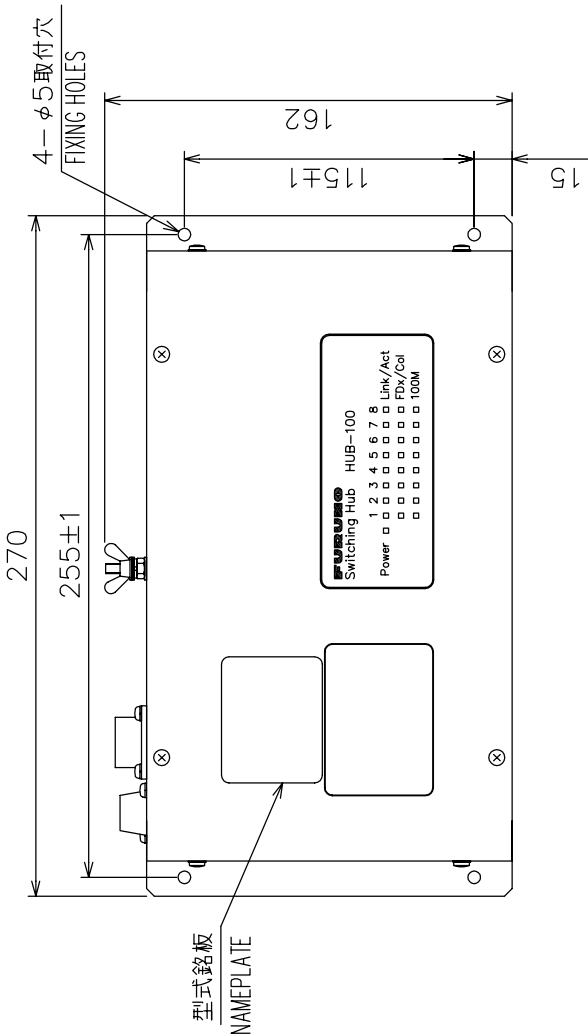

注 記

- 1) 取付用ネジはトラスタップネジ呼び径4×16を使用のこと
- 2) 指定外寸法公差は表1による
- 3) #印寸法は最小サービス空間寸法とする

NOTE

1. USE TAPPING SCREWS 4x16 FOR FIXING THE UNIT.
2. TABLE 1 INDICATES TOLERANCE OF DIMENSIONS WHICH IS NOT SPECIFIED.
3. # MINIMUM SERVICE CLEARANCE.

DRAWN	Mar. 31 '04	T. YAMASAKI	TITLE	HUB-100
CHECKED	Mar. 31 '04	T. MATSUGUCHI	名称	イーサネットスイッチングハブ
APPROVED	Apr. 05 '04	マツグチ	外寸図	
SCALE	1/3	MASS 1.5 kg ±10%	NAME	SWITCHING HUB
DWG.No.	C3519-G18-B			OUTLINE DRAWING



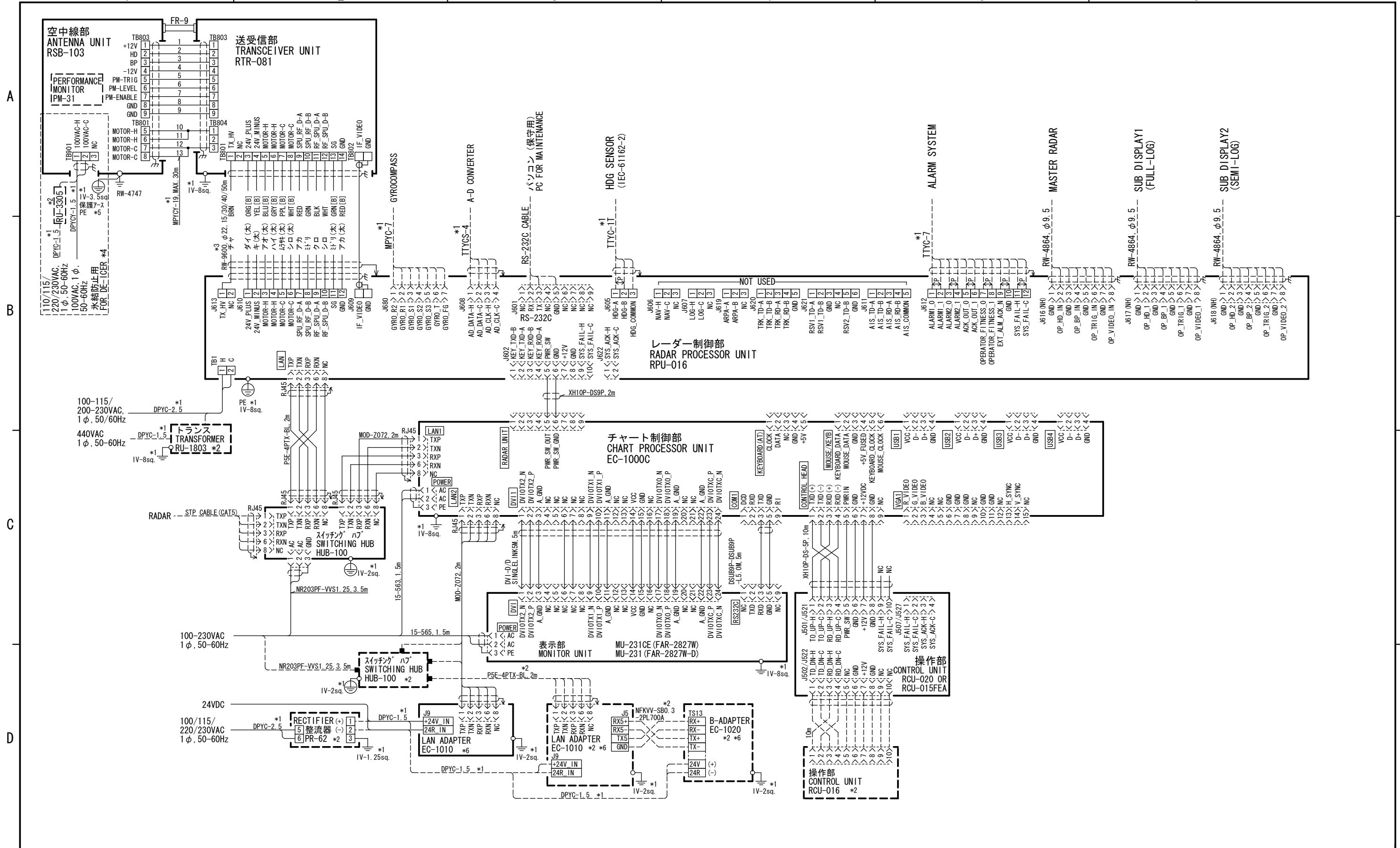

- 注記  
 \*1) 造船所手配。  
 \*2) オプション。  
 \*3) 最長 100m (延長するときは接続箱RJB-001が必要)  
 \*4) 船内配電盤では3Aのブレーカを使用。  
 \*5) 保護アース用ケーブルは緑/黄の絶縁線を使用のこと。  
 \*6) LANアダプタおよびB-アダプタの外部接続は別図参照。

- NOTES  
 \*1: SHIPYARD SUPPLY.  
 \*2: OPTION.  
 \*3: 100m MAX. JUNCTION BOX RJB-001 IS REQUIRED FOR EXTENSION.  
 \*4: USE 3A BREAKER IN SHIP'S MAINS SWITCH BOX.  
 \*5: USE GRN/YEL WIRE FOR PROTECTIVE EARTH.  
 \*6: REFER TO ANOTHER DIAGRAM FOR EXTERNAL CONNECTION OF LAN ADAPTER AND B-ADAPTER.

DRAWN	2/Mar/2011 T. YAMASAKI	TYPE	FCR-2827W (-D)
CHECKED	3/Mar/2011 H. MAKI	名称	自動衝突予防援助レーダー
APPROVED	3/Mar/2011 Y. NISHIYAMA		相互結線図
SCALE	MASS kg	NAME	MARINE RADAR/ARPA
DWG. No.	C3564-C01- C	REF. No.	03-173-6003-2
		INTERCONNECTION DIAGRAM	

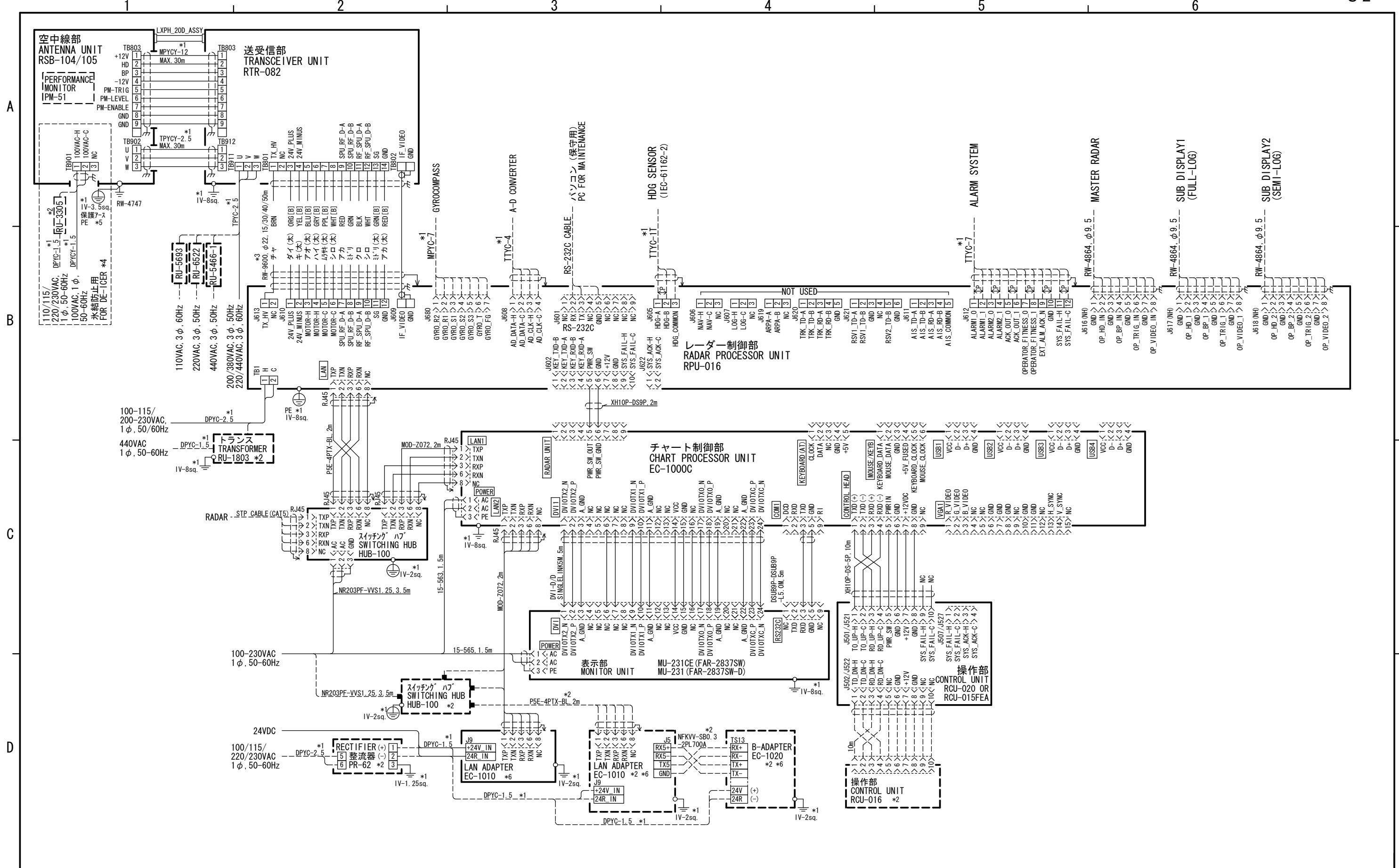

- 注記
- \*1) 造船所手配。
  - \*2) オプション。
  - \*3) 最長 100m (延長するときは接続箱RJB-001が必要)
  - \*4) 船内配電盤では3Aのブレーカを使用。
  - \*5) 保護アース用ケーブルは緑/黄の絶縁線を使用のこと。
  - \*6) LANアダプタおよびB-アダプタの外部接続は別図参照。

- NOTES
- \*1: SHIPYARD SUPPLY.
  - \*2: OPTION.
  - \*3: 100m MAX. JUNCTION BOX RJB-001 IS REQUIRED FOR EXTENSION.
  - \*4: USE 3A BREAKER IN SHIP'S MAINS SWITCH BOX.
  - \*5: USE GRN/YEL WIRE FOR PROTECTIVE EARTH.
  - \*6: REFER TO ANOTHER DIAGRAM FOR EXTERNAL CONNECTION OF LAN ADAPTER AND B-ADAPTER.

DRAWN	2/Mar/2011 T. YAMASAKI	TYPE	FCR-2837SW(-D)
CHECKED	3/Mar/2011 H. MAKI	名称	自動衝突予防援助レーダー
APPROVED	3/Mar/2011 Y. NISHIYAMA		相互結線図
SCALE	MASS kg	NAME	MARINE RADAR/ARPA
DWG. No.	C3566-C01- C	REF. No.	03-173-6004-2
		INTERCONNECTION DIAGRAM	

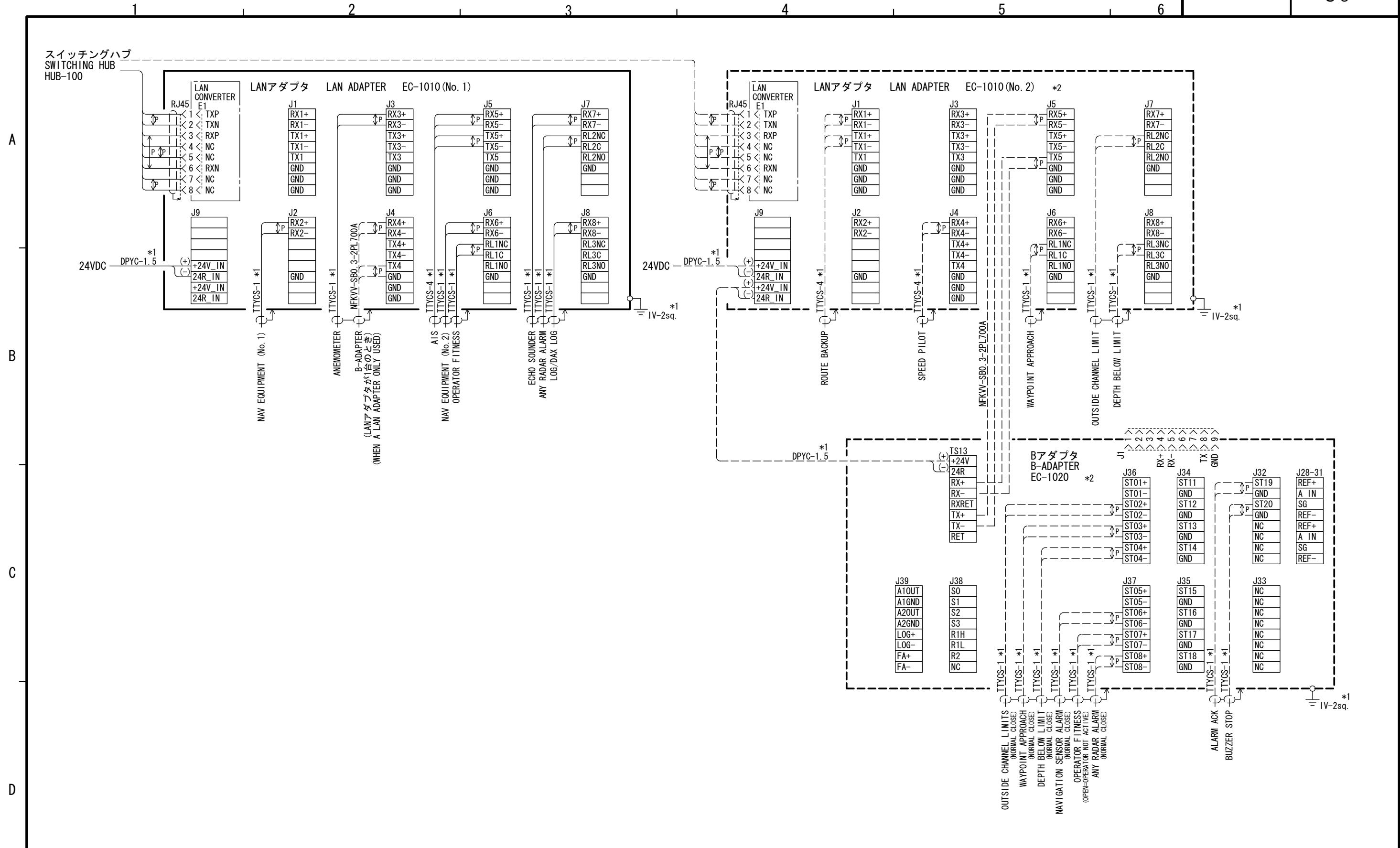

注記  
 \* 1) 造船所手配。  
 \* 2) オプション。  
 NOTE  
 \*1: SHIPYARD SUPPLY.  
 \*2: OPTION.

DRAWN	14/Apr/09 T. YAMASAKI	TITLE	EC-1010/1020
CHECKED	14/Apr/09 T. TAKENO	名称	LANアダプタ、B-アダプタ
APPROVED	11/May/09 R. Esumi FCR-2117SER.		相互結線図
SCALE	MASS kg	NAME	LAN ADAPTER, B-ADAPTER
DWG No.	C3559-C02- C		INTERCONNECTION DIAGRAM

## Free Manuals Download Website

<http://myh66.com>

<http://usermanuals.us>

<http://www.somanuals.com>

<http://www.4manuals.cc>

<http://www.manual-lib.com>

<http://www.404manual.com>

<http://www.luxmanual.com>

<http://aubethermostatmanual.com>

Golf course search by state

<http://golfingnear.com>

Email search by domain

<http://emailbydomain.com>

Auto manuals search

<http://auto.somanuals.com>

TV manuals search

<http://tv.somanuals.com>