

No. : OM-E3292-3F

FURUNO

OPERATOR'S MANUAL

MARINE RADAR

MODEL FR-604D



FURUNO ELECTRIC CO., LTD.
NISHINOMIYA, JAPAN

880950KY(8809,yuto)
PRINTED IN JAPAN

C O N T E N T S
 * * * * *

	<u>Page</u>
SPECIFICATIONS	0-1 to 0-4
CHAPTER 1 OPERATION INSTRUCTIONS	1-1 to 1-13
1.1 Function of Each Control	1-1
1.2 Operating Procedure	1-7
1.3 Range Measurement	1-8
1.4 Bearing Measurement	1-9
1.5 Radar Alarm Setting	1-10
CHAPTER 2 REMARKS ON VIEWING PICTURE	2-1 to 2-5
2.1 Minimum and Maximum Ranges	2-1
2.2 Radar Resolution	2-1
2.3 Bearing Accuracy	2-2
2.4 Range Measurement	2-2
2.5 False Echoes	2-2
CHAPTER 3 MAINTENANCE	3-1 & 3-2
CHAPTER 4 TROUBLESHOOTING	4-1 to 4-6
SCHEMATIC DIAGRAMS	S-0 to S-7
INTERCONNECTION DIAGRAM	S-8
OUTLINE DRAWINGS	D-1 to D-3

SPECIFICATIONS OF FR-604D
 * * * * *

SCANNER UNIT

- 1. Radiator: Slotted Waveguide Array
- 2. Radiator Length: 120cm
- 3. Horizontal Beamwidth: 2.0°
- 4. Vertical Beamwidth: 22°
- 5. Sidelobe Attenuation:
 - Within $\pm 20^\circ$ of mainlobe: -27dB
 - Outside $\pm 20^\circ$ of mainlobe: -30dB
- 6. Polarization: Horizontal
- 7. Antenna Rotation: 24 r.p.m. nominal

TRANSCIEVER MODULE (Contained in the scanner housing)

- 1. Transmitting Tube: Magnetron 9M302/E3513
- 2. Frequency & Modulation: 9410MHz \pm 30MHz, PON
- 3. Peak Output Power: 3kW nominal
- 4. Pulselength & Pulse Repetition Rate:

Range	0.25	0.5	1.5	3	6	12	24	48
Pulse Repetition Rate	Approx. 3360Hz			Approx. 840Hz				
Pulselength	0.08us (Short)			0.5us (Long)				

- 5. Modulator: SCR Line Type Pulse Modulator
- 6. I.F.: 60MHz
- 7. Tuning: Manual
- 8. Receiver Front End: MIC (Microwave IC)
- 9. Bandwidth: 7MHz/3MHz
- 10. Duplexer: Circulator with Diode Limiter

DISPLAY UNIT

- 1. Indication System: Raster Scan, Daylight Display
- 2. Picture Tube: 9-inch rectangular CRT

3. Range (nm)	0.25	0.5	1.5	3	6	12	24	48
4. Range Ring Interval (nm)	0.125	0.125	0.25	0.5	1	2	4	8
5. Number of Rings:	2	4	6	6	6	6	6	6
6. Bearing Resolution:	2°							
7. Bearing Accuracy:	Better than 1°							
8. Range Discrimination:	Better than 25m							
9. Minimum Range:	Better than 25m							
10. Range Ring Accuracy:	1.5% or 70m, whichever is the greater							
11. VRM Accuracy:	1.5% or 70m, whichever is the greater							
12. Markings:	Heading Mark, Bearing Scale, Range Ring, VRM, EBL, Alarm Zone, Tuning Bar							
13. Legends	Range, Range Ring Interval (RINGS), EBL Bearing, VRM Range, Interference Rejection (IR), ST-BY, FTC, Alarm (ALARM)							
14. Interference Rejector:	Built-in							
15. Radar Alarm:	Built-in							

ENVIRONMENT CONDITION

1. Vibration:	Vibration Freq.	Total Amplitude
	1 to 12.5Hz	+ 1.6mm
	12.5 to 25Hz	+ 0.38mm
	25 to 50Hz	+ 0.10mm
2. Ambient Temperature:	Scanner Unit -----	-25°C to +70°C
	Display Unit -----	-15°C to +55°C
3. Humidity:	Relative humidity, 93% ± 2% at +40°C ± 3°C	

POWER SUPPLY & POWER CONSUMPTION

10.2VDC - 40.0VDC, 45W (no wind load) or
 100/110/115/220/240VAC, 50/60Hz, 1φ, 110VA (no wind load)
 (Rectifier needed)

EQUIPMENT LIST

No.	Name	Type	Weight (kg)	Q'ty
1	Scanner Unit	RSB-0024	23	1
2	Display Unit	RDP-042	6.9	1
3	Accessories	FP03-02000		1 set
4	Standard Spare Parts	SP03-02500		1 set
5	Installation Materials			1 set

OPTIONAL SUPPLY

No.	Name	Type	Weight (kg)	Q'ty	Remarks
1	Rectifier	RU-3423	16.5	1	AC mains only
2	Power Cable	VV-S 2.0x2C		1	Cable length:5m
3	External Buzzer	OP03-21		1	For alarm

ACCESSORIES (Type: FP03-02000, Code No.: 000-081-029)

No.	Name	Type	Code No.	Q'ty
1	Bracket Assy.	FP03-02010	008-204-980	1
2	Washer	8.2x30.0x1.0	000-800-486	2
3	Knob Bolt	KG-B3 M8x25	000-800-964	2
4	Hood Assy.	FP03-01620	003-160-660	1
5	Panhead Tapping Screw	6x20 SUS304	000-800-414	5
6	Flat Washer	M6 SUS304	000-864-129	5

STANDARD SPARE PARTS (Type: SP03-02500, Code No.: 000-081-370)

No.	Name	Type	Code No.	Q'ty
1	Fuse	FGMB 10A AC125V	000-104-815	2
2	Carbon Brush	For RM-3622	000-430-890	2
3	L-handle Socket Wrench	Diagonal 13mm	000-830-110	1
4	Spare Parts Box	For F710	000-831-610	1

INSTALLATION MATERIALS

For Display Unit

No.	Name	Type	Code No.	Q'ty	Remarks
1	Connector	FM-142P	000-511-406	1	For power cable
2	Signal Cable Assy.	S03-11-10 (10m)	008-204-690	1	To be selected (With connector at display end)
		S03-11-15 (15m)	008-204-700		
		S03-11-20 (20m)	008-204-710		
		S03-11-30 (30m)	008-204-720		

For Scanner Unit

No.	Name	Type	Code No.	Q'ty
1	Connector	CN-7042	000-510-580	1
2	Lug	φ4	000-536-100	4
3	Crimp-on Lug	FV5.5-4	000-538-123	1
4	Crimp-on Lug	FV1.25-3 RED	000-538-113	22
5	Seal Washer	CW1053DX	000-850-021	4
6	Hex. Bolt	M12x60 SUS304	000-862-191	4
7	Hex. Nut	M12 SUS304	000-863-112	4
8	Flat Washer	M12 SUS304	000-864-132	4
9	Spring Washer	M12 SUS304	000-864-263	4
10	Slotted Pin G-type	10x45 SUS	000-866-390	2
11	Drain Tube	03-003-3001-0	300-330-010	1
12	Hex. Bolt	M8x30 SUS304	000-862-187	4
13	Flat Washer	M8 SUS304	000-864-130	4
14	Spring Washer	M8 SUS304	000-864-262	4
15	O-ring	JISB2401-1A-G80	000-851-313	1
16	Adhesive	#1211 (50g)	000-854-118	1

Assembly from No.1 to No.11 --- Type: CP03-02801, Code No.: 008-206-960

CHAPTER 1 OPERATION INSTRUCTIONS

Adjustment and function for the respective operating controls are discussed in this chapter. Operating personnel should familiarize themselves with all the operating controls in order to make the best possible use of the equipment.

1.1 Function of Each Control (Refer to page 1-13.)

POWER Button

When this button is pressed, power is applied to all circuits of the radar system. Both the "ON" LED above the power button and the touchpad panel will light up, and the antenna will begin to rotate. To cut off power to the radar, press the button again.

Shortly after the radar set is turned on, the screen will read as shown in Fig.1-1 and the standby timer will begin to count down from 2min. 30 sec. When it reaches "0:01" the screen will display ST-BY, signifying the radar is ready for operation. Press the TX touchpad to begin transmission. The GAIN and TUNE controls should be adjusted to display the radar picture.

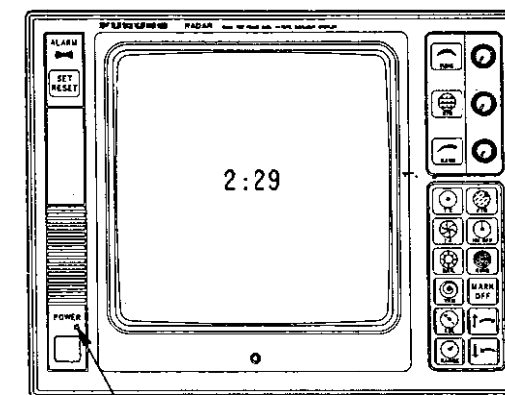

Power "ON" LED

Fig.1-1

After 2 min. 30 sec.

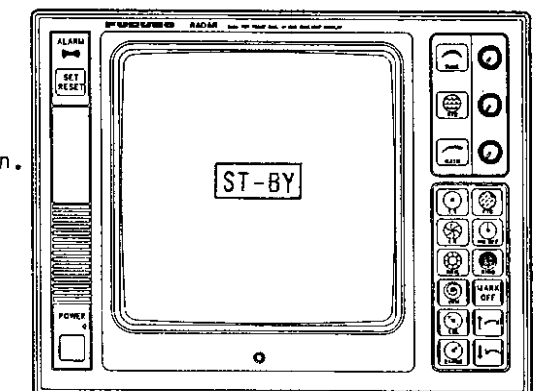
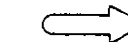
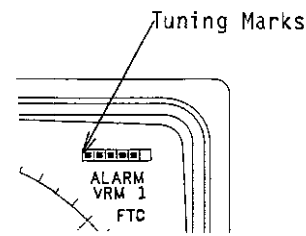

Fig.1-2

The following three controls are grouped together because they control the radar receiver. To prevent accidental alteration of the settings, all controls in this group may be locked by pushing in the control. When readjustment is necessary, push in and release the control to bring it out again.

TUNE Control 

After the radar is set to transmit, this control is used to tune the receiver to the exact frequency of the transmitter. The tuning condition of the receiver can be confirmed at any time by checking the tuning bar at the top right-hand corner of the screen. The receiver is tuned properly when the greatest number of tuning marks is displayed. To tune the receiver, set the range to maximum and rotate the tune control between its extremes to display the greatest number of tuning marks(4 or 5).



GAIN Control 

This control adjusts the sensitivity of the receiver. When the control is turned clockwise the sensitivity of the receiver is raised, and the echoes of targets are displayed on the screen. If the radar is set on one of the longer ranges, the radar is adjusted properly when the speckled background on the screen just fades out. On short ranges, it is recommended that the GAIN control be set almost fully clockwise and the STC control be used to adjust the sensitivity.

STC Control 

This control reduces the gain at close ranges, in order to suppress reflections from waves near own ship. When the control is turned clockwise, the sensitivity is reduced at close ranges (where sea clutter is the greatest) and the strength of echoes on greater ranges is restored gradually. The control is adjusted so that targets masked by the clutter remain on the screen; only the clutter is removed. If the control is turned too far to the right, the echoes from desired targets may be lost. Therefore adjust the control prudently. Set the control to the fully counterclockwise position when no clutter is visible on the screen.

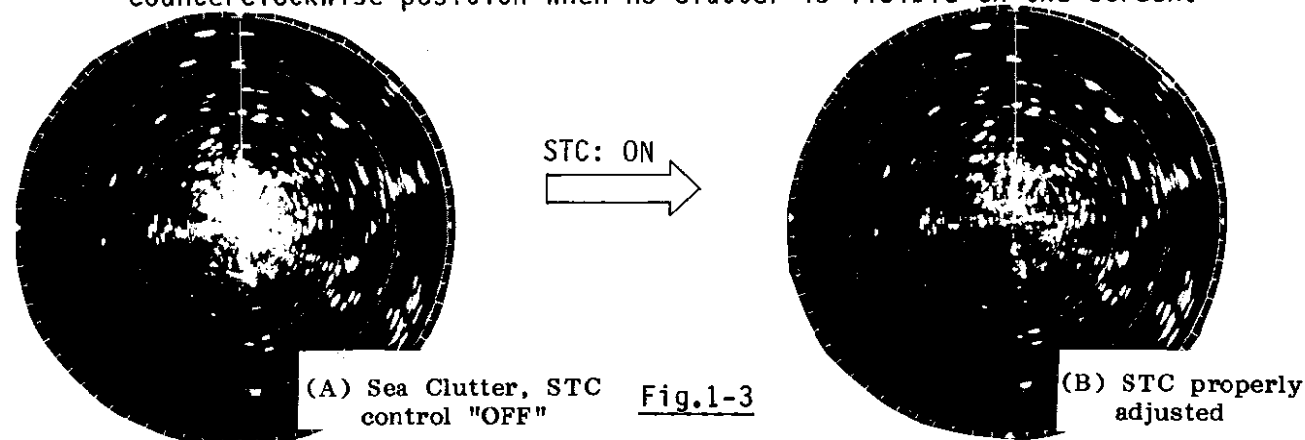



Fig.1-3

The following are the functions of each touchpad.



TX Touchpad 



Press this touchpad to alternate between transmit and ST-BY modes. After standby is completed, press the touchpad to begin transmitting.

After the radar is set to transmit the GAIN and TUNE controls are adjusted to display the radar picture. When the radar will not be used for an extended period of time, press the TX touchpad to set the radar to ST-BY. The message "ST-BY" will appear at the middle of the screen.

BRIL Touchpad 

This touchpad changes the brightness of the CRT in 4 steps. Every depression of the touchpad changes the brightness stepwise.

RANGE & ARROW Touchpads  &  / 

The range selected automatically determines the fixed range ring interval, the number of fixed range rings and transmission pulse length, for optimal detection in both short and long ranges (see the Specifications). To select a range, press the RANGE touchpad, followed by pressing either the  /  touchpad, depending on whether you want to select a higher range or a lower range respectively. The range in use and corresponding fixed range ring interval are displayed at the top left-hand corner of the screen.

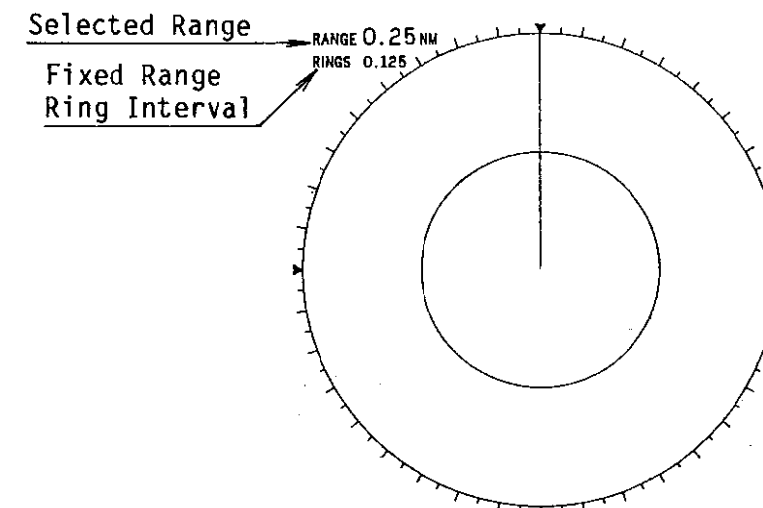



Fig.1-4

FTC (on/off) Touchpad 

Echoes of ships operating inside rain, snow or hail storms may be hidden by the clutter displayed on the screen. When heavy storms or partial clutter is visible on the screen, press this touchpad to remove the clutter. Furthermore, when this touchpad is pressed in clear weather, it may be used to separate groups of echoes on a congested short range picture. If the FTC is activated, the letters "FTC" are displayed at the top right-hand side of the screen. To cancel the FTC function at any time, press the FTC touchpad again.

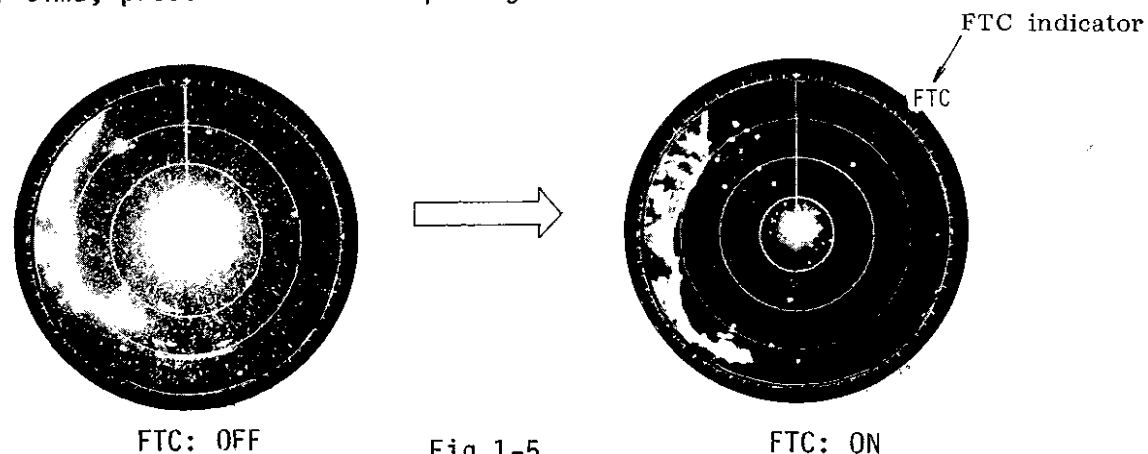



Fig.1-5

IR (on/off) Touchpad 

Should radar interference from other radars operating in the vicinity be observed on the screen (see Fig.1-6) this touchpad may be pressed to eliminate or suppress the interference. The interference rejector circuit is switched on whenever power is applied. Therefore deactivate the circuit when there is no interference. The letters "IR" appear at the top right-hand side of the screen when the circuit is activated.

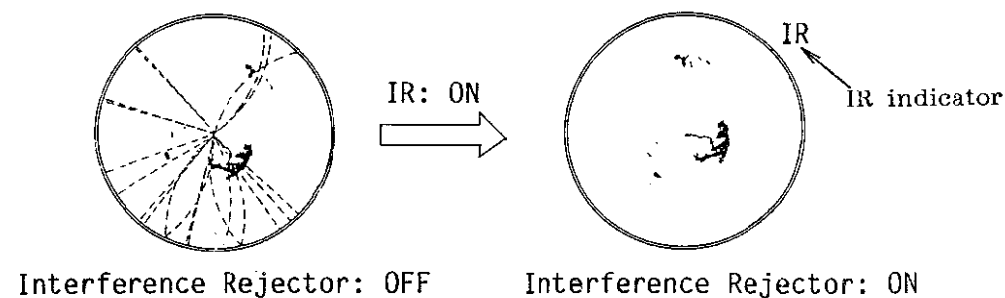



Fig.1-6

HM OFF Touchpad 



Should you desire to observe a small echo under the ship's heading mark, press and hold this touchpad to erase the mark from the screen.

RING (on/off) Touchpad 



The RING touchpad is pressed to turn on/off the fixed range rings. The fixed range rings are presented on the screen everytime the power is turned on. Therefore, press the touchpad to erase the rings from the screen when they are not needed.

As noted earlier the number and interval of the rings are related to the range in use. See the Specifications. The interval is displayed below the range in use at the top left-hand corner of the screen. See Fig.1-7.

VRM  & ARROW  /  Touchpads

The VRM touchpad is pressed to display the VRM and its range indicator at the lower right-hand side of the screen. Then, press either the  /  touchpad to increase or decrease the range of the VRM respectively.

EBL  & ARROW  /  Touchpads

The EBL touchpad is pressed to display the EBL and its bearing indicator at the lower left-hand side of the screen. Then, press either the  /  touchpad to rotate the EBL clockwise or counterclockwise respectively.

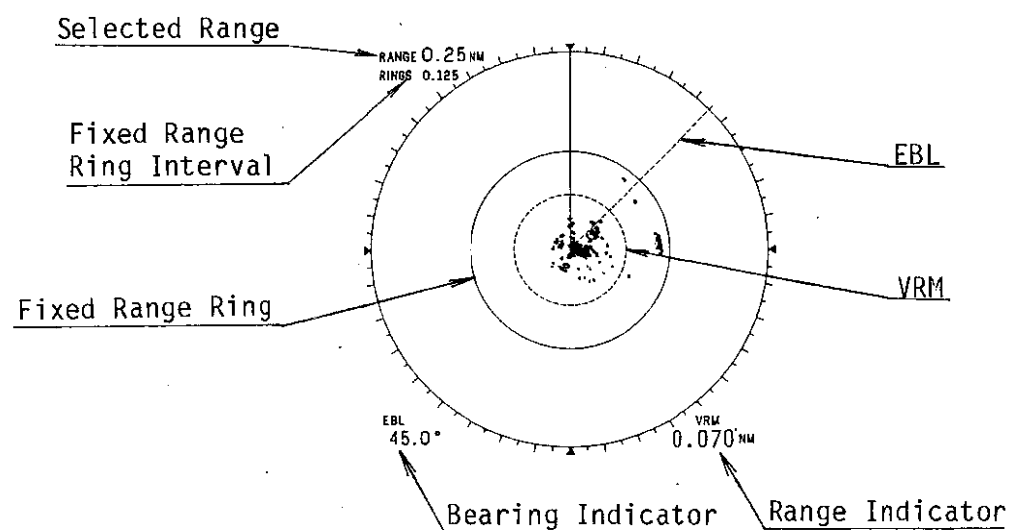







Fig.1-7

ARROW Touchpad (used with VRM/EBL/RANGE)  / 

The two arrow touchpads are tri-colored to signify that they are used in conjunction with the EBL, VRM or RANGE touchpad. When activated by pressing one of the above three touchpads, the arrow touchpads are used to maneuver the markers which are used to measure the bearing and range of a target appearing on the display screen (EBL and VRM respectively), or change the range scale in use, depending on which touchpad is pressed. The  touchpad is used to rotate the EBL clockwise, or move the VRM out away from the center of the CRT, or select a higher range scale. The  touchpad performs the same function as the  touchpad except that it works in the opposite direction, e.g., it rotates the EBL counterclockwise, moves the VRM closer to the center, or selects a lower range scale. For operator convenience, a green light frames the on-screen indicator of the touchpad last pressed, among EBL, VRM and RANGE. This permits quick recognition of which setting can be changed without having to press the touchpad.

MARK OFF Touchpad 

The MARK OFF touchpad is colored green and orange to indicate that it is used in conjunction with the EBL and VRM touchpads. Its function is to erase the EBL and/or VRM from the screen.

ALARM SET/RESET Touchpad 

The alarm is set by maneuvering the EBL and VRM to the desired guard zone followed by pressing the SET/RESET touchpad once. The message "ALARM" is displayed at the top right-hand side of the screen to alert the operator that the alarm is activated. Press and hold the SET/RESET touchpad for at least two seconds to cancel the alarm.

After the alarm is set the EBL and VRM may be operated without disturbing the settings of the alarm. Note that it is possible to set the range alarm only. The bearing sector alarm can not be set without first setting the range alarm. For further details about how the alarm is set, see page 1-10.

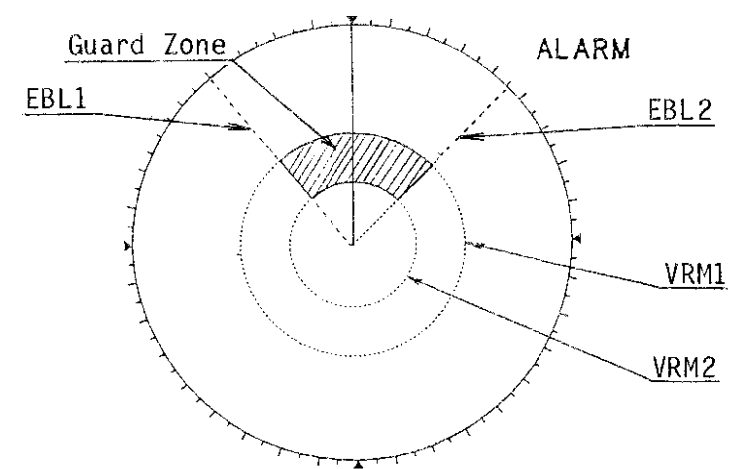

Fig.1-8

1.2 Operation Procedure

Confirm that the following points are satisfied before turning on the radar.

- 1) Confirm that the power supply is within the rating.
- 2) Make sure there are no obstructions around the antenna.
- 3) Check that the settings of the controls are as shown below.

Button & Controls	Settings
POWER	OFF
GAIN & STC	Fully CCW
TUNE	Center
Others	Any positions

Starting

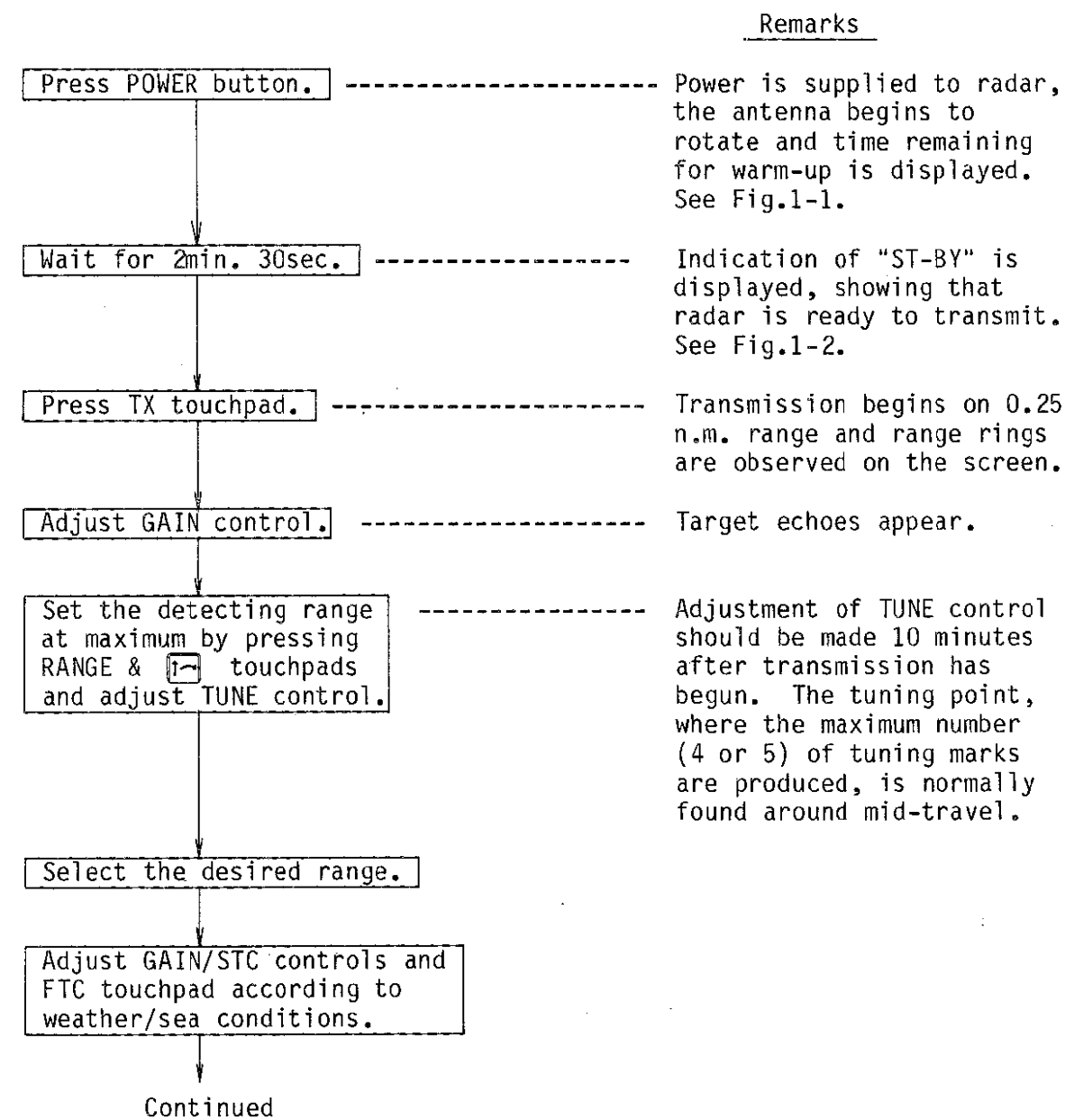

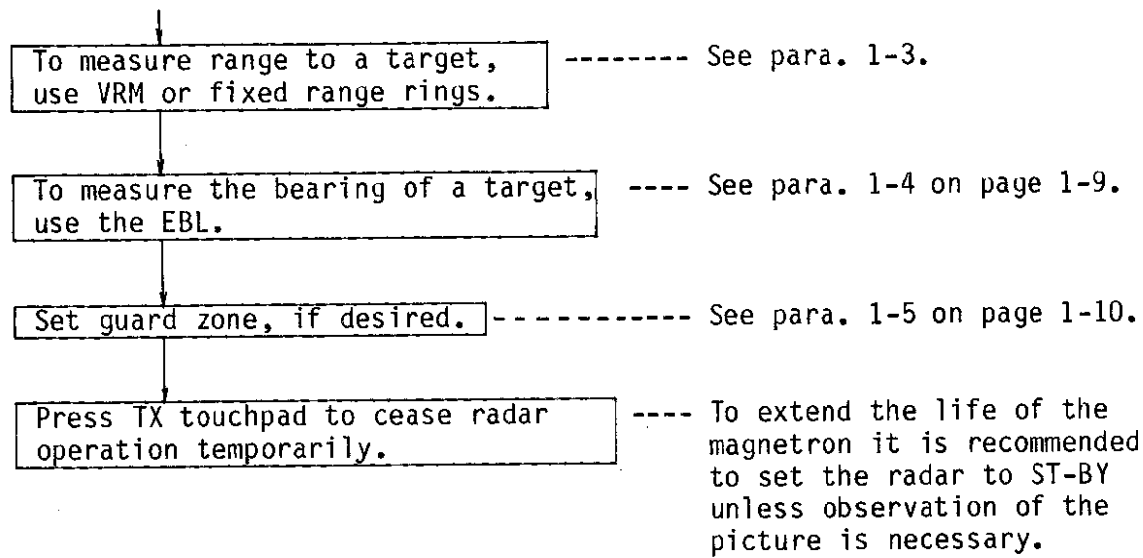

Stopping

Ensure the GAIN control is turned fully counterclockwise before turning off the power.

1.3 Range Measurement

1) Range Measurement with the Fixed Range Rings

The range to a target is measured roughly with the fixed range rings. The rings are displayed on the screen by pressing the RING touchpad. To measure the range to a target, first check the range ring interval, shown at the upper left-hand corner of the screen. Then count the number of rings between the center of the CRT and the target, and estimate the range to the target.

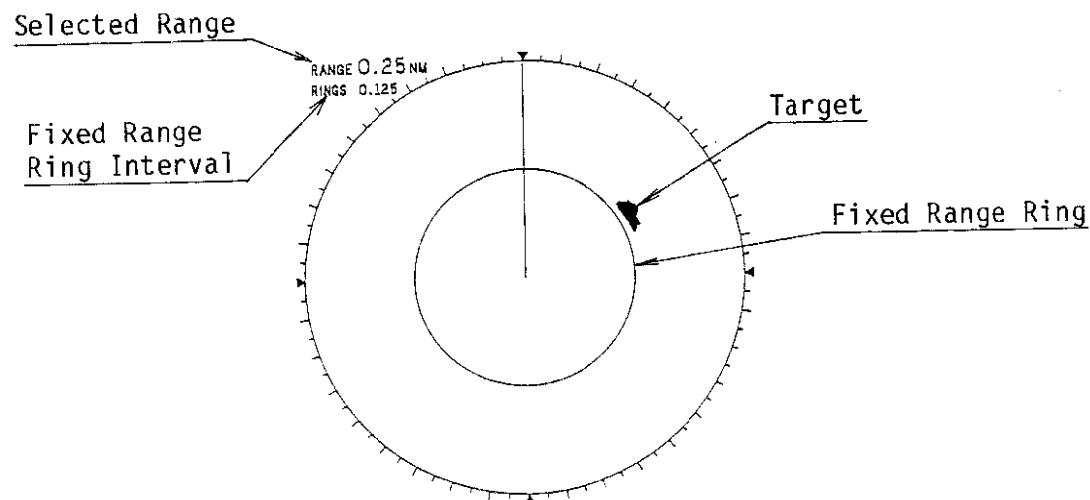

Fig.1-9

2) Range Measurement with the VRM

The range to targets can be measured more accurately using the VRM.

1. Press the VRM touchpad to display the VRM on the screen.
2. Press or touchpad until the circle described by the VRM touches the inside edge of the target.
3. The range measured by the VRM can be read at the lower right-hand corner of the screen.

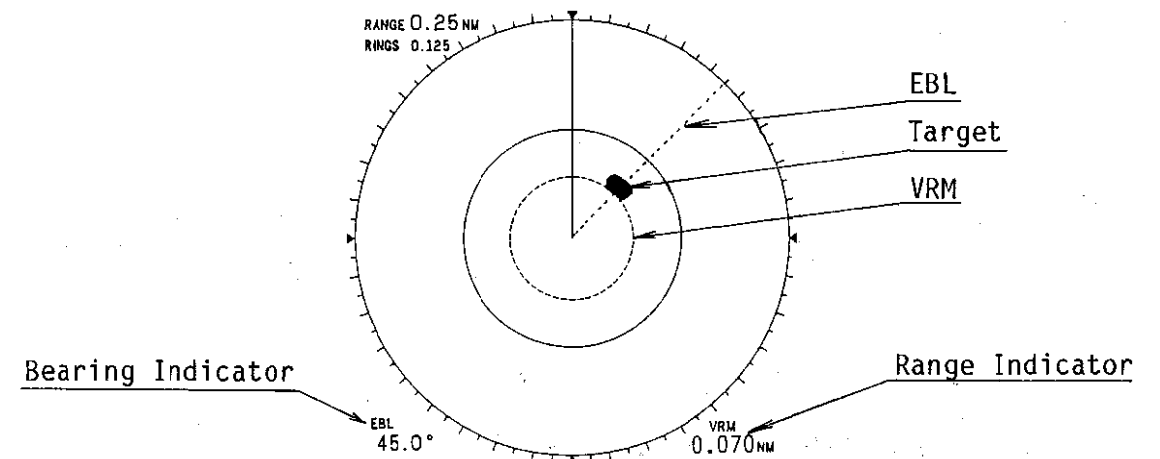

Fig.1-10

1.4 Bearing Measurement

1. Press the EBL touchpad to display the EBL on the screen.
2. Press or touchpad until the EBL is positioned over the center of the target.
3. The bearing measured by the EBL can be read at the lower left-hand corner of the screen. (The bearing measured is relative to own ship.)

1.5 Radar Alarm Setting

The alarm function allows the operator to set the desired range (0 to maximum range) and bearing (0 to 360°) for a guard zone. Should ship's, islands, landmasses, etc. come into the guard zone an alarm will be generated. The alarm is very effective as an anti-collision aid when using an autopilot or navigating in narrow channels.

Although the alarm is useful as anti-collision aid, it does not relieve the operator of the responsibility to watch out for possible collision situations. The alarm should not be used as a primary means to detect possible collision situations.

Now the procedure to set the alarms.

Procedure

Before setting the alarm ensure the gain is set properly. Too high a gain will trip the alarm needlessly, and if the gain is set too low weaker targets may be missed; the alarm will not sound should weaker targets come into the guard zone. To set, for example, a guard zone between 2.20 and 3.30nm use the following procedure.

1. Set the range at 6nm; press the VRM touchpad to display the VRM marker on the screen. VRM1 is displayed at the top right-hand side of the screen.
2. While observing the VRM indicator at the lower right-hand side of the screen, press / until the VRM stops at 3.30nm. (The order which you set the inner and outer range limits is interchangeable.) See Fig.1-11.
3. Press the SET/RESET touchpad once, and the outer/inner range of the alarm is set. At this time a weak intensity ring is overlaid on the VRM to mark the inner or outer limit of the guard zone. Furthermore, the message "VRM1" will change to "VRM2," and the message "ALARM" is displayed at the top right-hand side of the screen, indicating the alarm is now activated. See Fig.1-12.

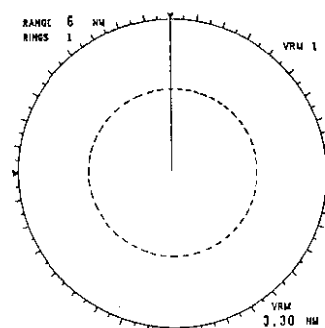

Fig.1-11

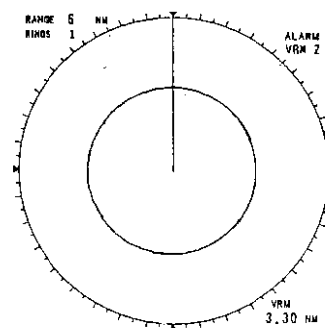

Fig.1-12

4. Press / until the VRM stops at 2.20nm and press the SET/RESET touchpad. A "doughnut ring" marks the inner and outer limits of the alarm. See Fig.1-13 and Fig.1-14.
5. To change the inner or outer range of the alarm, repeat steps 2 thru 4. Now if a target comes into the zone marked by the doughnut ring an alarm is sounded. You may cancel the alarm at any time by pressing and holding the SET/RESET touchpad for at least two seconds. If the guard zone goes out of the screen when changing to a lower range, the message "UP RANGE" is displayed at the top right-hand side of the screen, informing you to up the range to redisplay the guard zone on the screen.

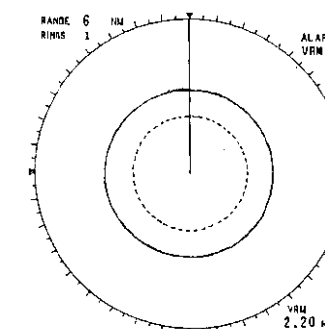

Fig.1-13

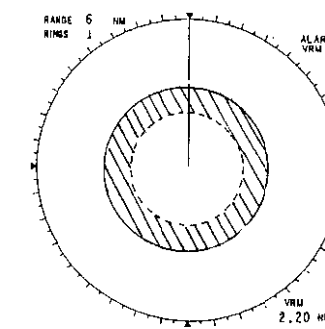

Fig.1-14

If you desire to set a bearing sector alarm as well, proceed to the next step.

To set, for example, a 90° bearing sector between 315° and 45°, use the following procedure.

6. Press the EBL touchpad to display the EBL on the screen. EBL1 is displayed at the top right-hand side of the screen.
7. By observing the EBL indicator at the lower left-hand side of the screen, press the / touchpad until the EBL is positioned at 315°. See Fig.1-15.
8. Press the SET/RESET touchpad, and the bearing in step 7 is set. A small 2-3 degree blank space is created in the doughnut ring at the area around 315°, however it is "repainted" once the other side of the bearing sector is set. At this time the EBL1 indication will change to EBL2, indicating you should set the other side of the bearing sector. See Fig.1-16.

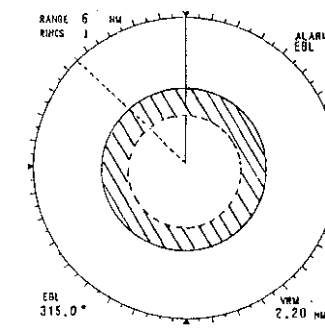

Fig.1-15

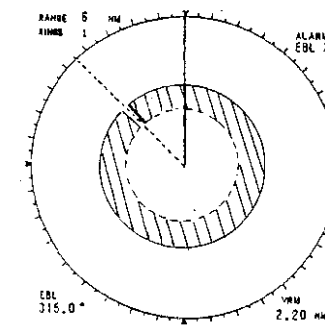



Fig.1-16

9. Then, press  /  to position the EBL at 45°, and hit the SET/RESET touchpad. The setting of the guard zone is now completed. To change the bearing sector, repeat steps 7 and 8. See Fig.1-17 and Fig.1-18.
10. Any ships, islands, landmasses, etc. coming into the guard zone will trigger the alarm, telling the operator to proceed with caution. The guard zone and alarm sound may be cancelled at any time by pressing and holding the SET/RESET touchpad for at least two seconds.

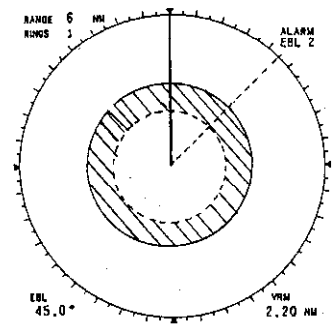

Fig.1-17

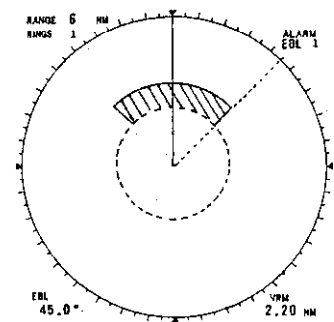

Fig.1-18

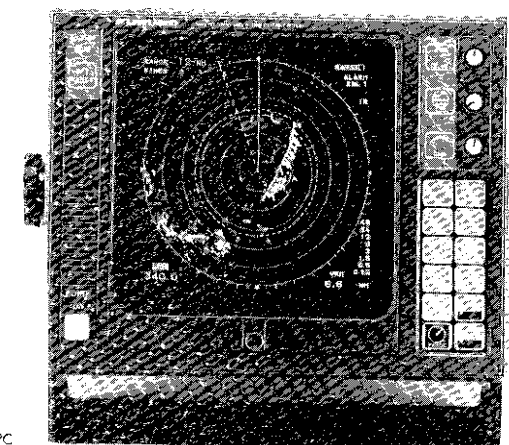
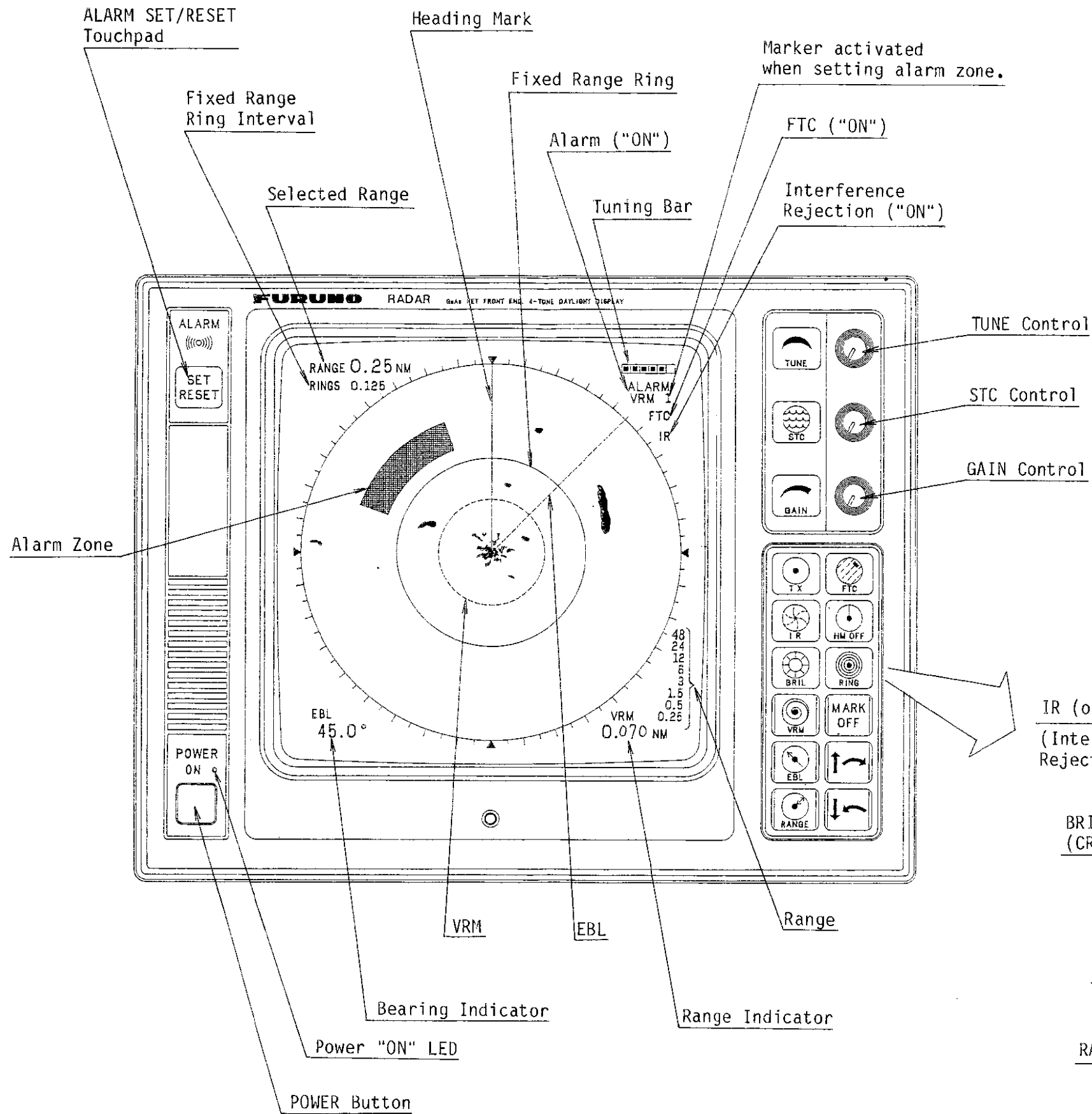
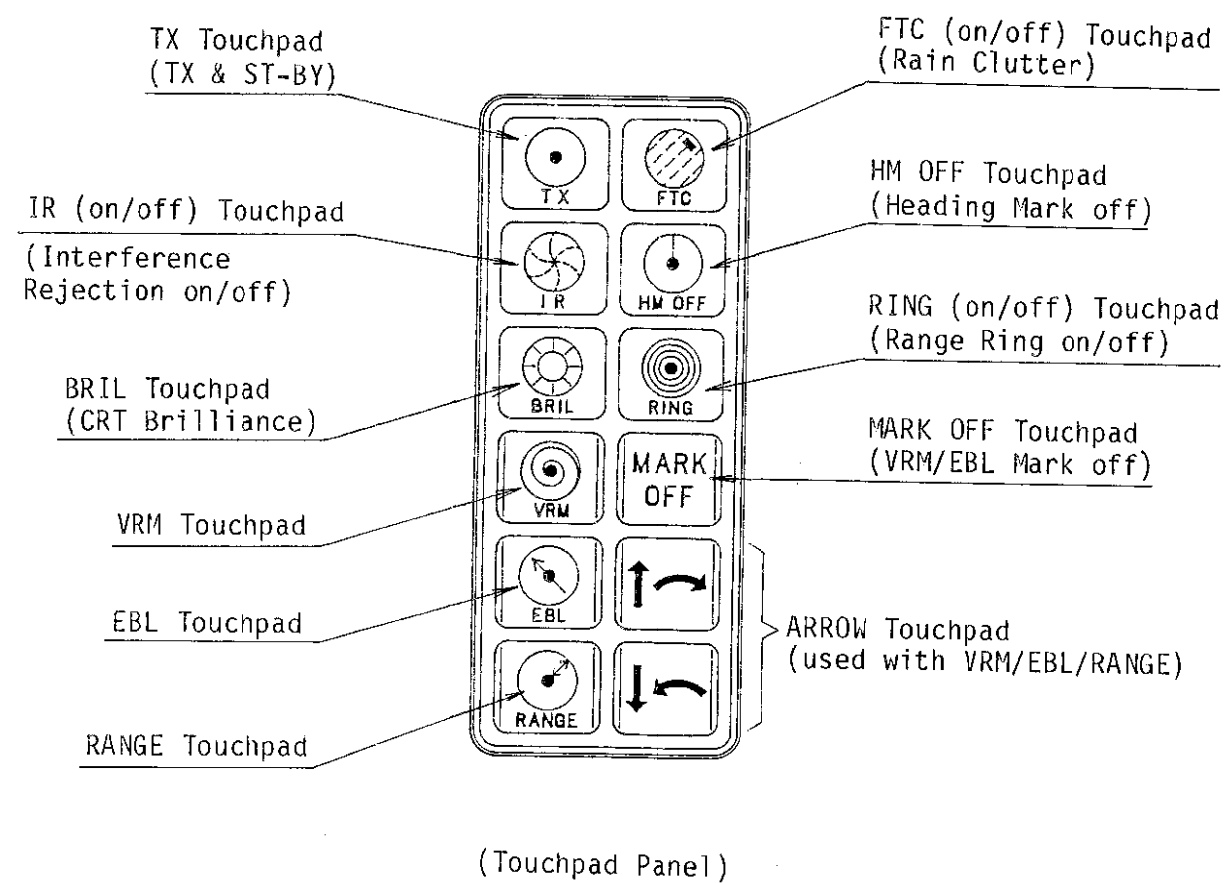

Photo No. 2132 PC



CHAPTER 2 REMARKS ON VIEWING PICTURE

2.1 Minimum and Maximum Ranges

Maximum range

The maximum detecting range of the radar, R_{max} , varies considerably depending upon several factors such as the height of the antenna above the sea, the height of the target above the sea, the size, shape and material of the target, and the atmospheric conditions.

Under normal atmospheric conditions, the maximum range is equal to the radar horizon or a little shorter. The radar horizon is longer than the optical one by about 6% because of the diffraction property of the radar signal. The R_{max} is given in the following equation.

$$R_{max} = 2.2 \times (\sqrt{h_1} + \sqrt{h_2})$$

where R_{max} : Radar horizon (n. mile)
h1 : Antenna height (meter)
h2 : Target height (meter)

For example, if the height of the antenna above the sea is 9 meters and the target height is 16 meters, the maximum radar range is;

$$\begin{aligned} R_{max} &= 2.2 \times (\sqrt{9} + \sqrt{16}) = 2.2 \times (3 + 4) \\ &= 15.4 \text{ (n. miles)} \end{aligned}$$

Minimum Range

When the radar is used as a collision avoidance aid the minimum range is of urgent concern. It is very dangerous for a target to disappear when it approaches the ship. The minimum range is determined by the transmission pulse width and the height of the antenna (vertical beam width of antenna) above the sea.

2.2 Radar Resolution

Bearing Resolution

Bearing resolution is the ability to discriminate two targets which are located at the same range and close to each other. It is proportional to the length of the antenna and reciprocally proportional to the wave length. The usual bearing resolution is 1 to 3 degrees.

Range Discrimination

Range discrimination is the ability to distinguish two targets which are in the same direction and close to each other. This is determined by pulselength only. The average discrimination range is 25 yards on a 0.08 micro-second pulse.

2.3 Bearing Accuracy

One of the most important features of the radar is how accurately the bearing of the target can be measured. The accuracy of the bearing measurement basically depends on the narrowness of the radar beam. However, the bearing is usually taken relative to the ship's heading, and thus, the adjustment of the heading marker at installation is an important factor to determine bearing accuracy. To minimize error when measuring the bearing of a target, put the target echo at the extreme position on the screen by selecting a suitable range.

2.4 Range Measurement

Measurement of the range to a target is also a very important function of the radar. Generally, there are two means of measuring the range: the fixed range rings which appear on the screen with a predetermined interval as a reference of the range measurement, and the variable range marker which can be moved inwards and outwards so that it will touch the inside edge of the target. The range to the target measured by the VRM is displayed digitally.

2.5 False Echoes

Occasionally echo signals appear on the screen at positions where there is no target or disappear even if there are targets. They are, however, recognized if you understand the reason why they are presented. Typical false echoes are shown below.

Multiple Reflection

When a wide and plane target such as the sideboard of a ship, bridge, building on a pier and breakwater exists near the ship, radar pulses are multi-reflected between your ship and the target. This results in presentation of multiple echoes on the screen. The multiple echoes appear at equal intervals after the true echo as shown in Fig.2-1.

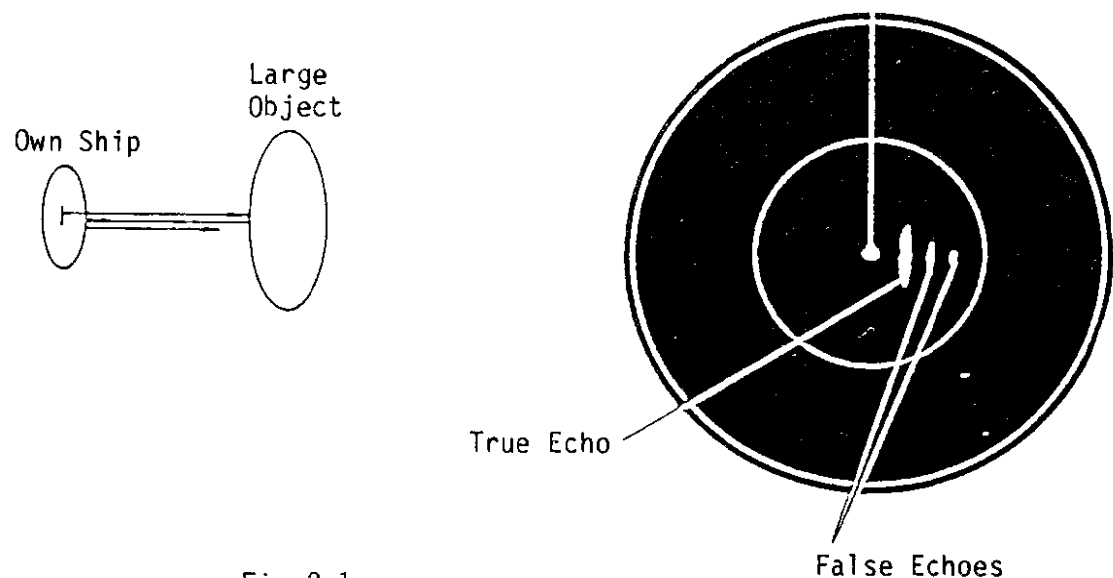

Fig.2-1

Spurious Echoes

When the radar pulse is emitted from the antenna radiator, some of the total emitted energy escapes on each side of the main beam--sidelobes. If the target is strong, it can be detected by the sidelobes as well as the main lobe, the spurious echoes may be represented at both sides of the true echo with the same range as shown in Fig.2-2. Spurious echoes can be removed by adjusting the GAIN and STC controls.

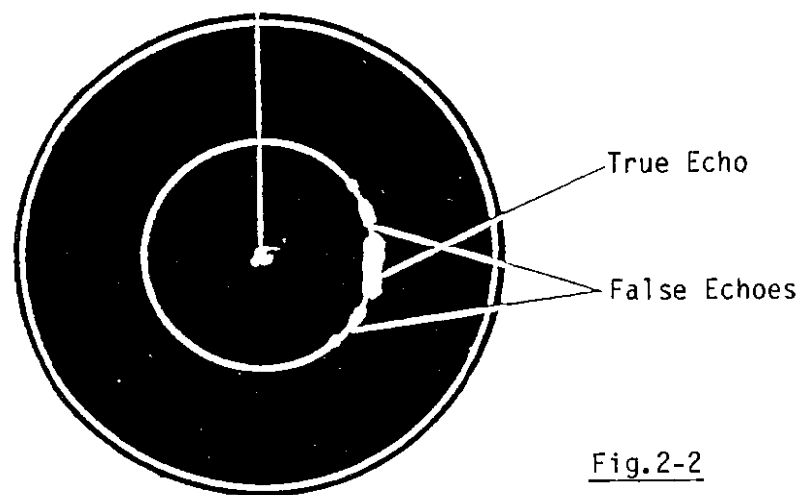

Fig.2-2

Second-trace Echoes

If radio wave propagation is extraordinary, echoes from very distant targets may appear on the screen. In this case, they may return after the echoes from the next transmission pulse have appeared. Thus false echoes appear together with the true echoes of the near distant targets.

Virtual Image

A relatively large target close to your ship may be represented at two positions on the screen. One of them is the true echo directly reflected by the target and the other is a false echo which is caused by the mirror effect of a large object on or close to your ship as shown in Fig.2-3. If, for example, your ship comes close to a large steel bridge such a false echo may temporarily be seen on the scope.

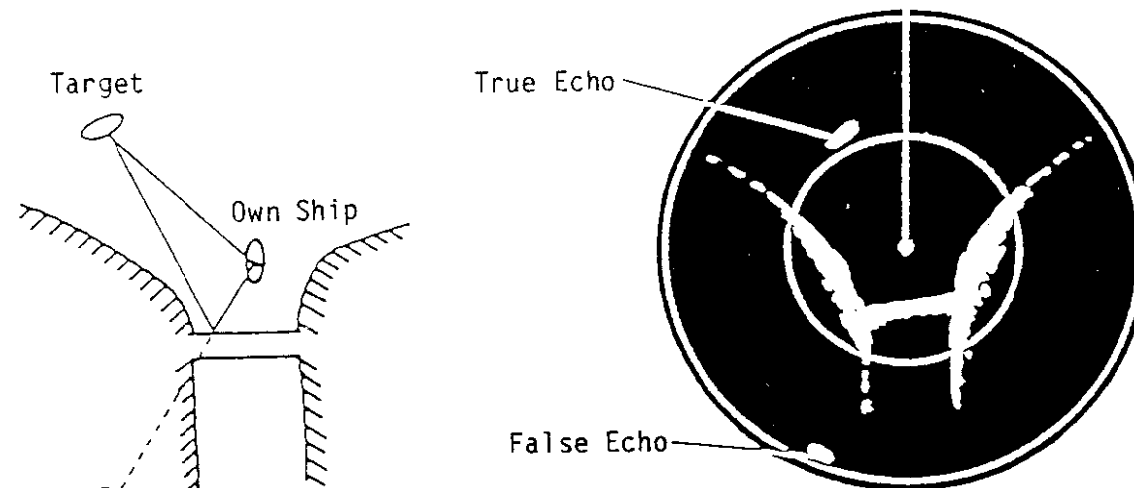

Fig.2-3

Dead Angle (Blind Sector)

A funnel, mast or derrick post near the radar antenna may intercept the radar beam. In that case, no target is detected within a certain angle--called a "dead angle." A large object close to your ship may produce a similar effect.

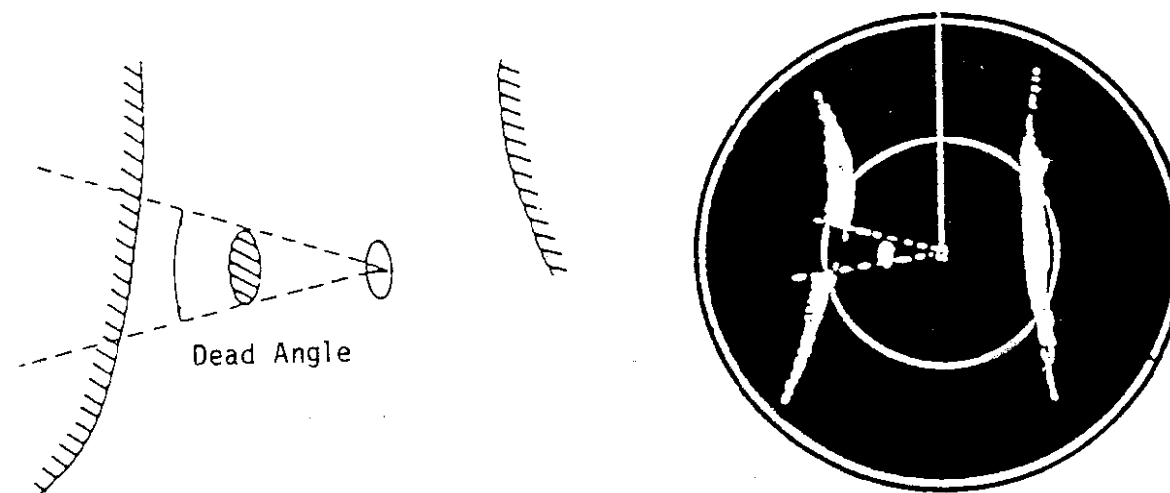

Fig.2-4

Radar Interference

When another ship is operating a radar the same frequency as your own ship's radar, the radar pulses emitted from the other ship are received and appear on your radar screen as the curved spokes shown in Fig.2-5.

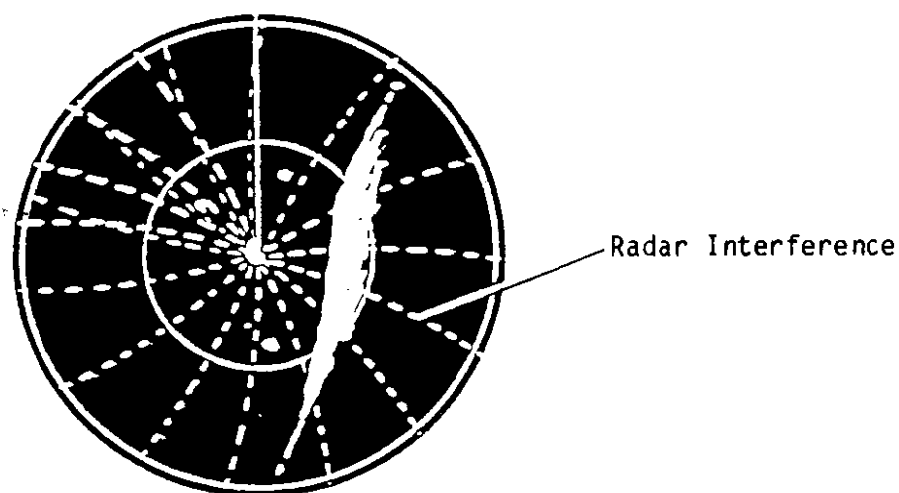

Fig.2-5

CHAPTER 3 MAINTENANCE

To maintain optimum performance of the equipment for an extended period, general check and maintenance should be made periodically.

"CAUTION"

Before maintenance work, be sure to switch off the radar at the main switch-board. When checking inside the units, wait for a few minutes until the high voltage components (CRT or HV capacitors) can discharge the residual charge.

Interval	Item	Check/Measures	Remarks
3 to 6 months	Exposed bolts and nuts on scanner unit	Check for corroded or loosened bolts/nuts. If necessary, clean them and repaint thickly. Replace them with new ones if heavily corroded.	*Sealing compound may be used instead of paint. *Put slight amount of grease if bolts and nuts are replaced.
	Scanner radiator	Check for dirt or cracks on the radiator surface. Thick dirt should be wiped off by using a soft cloth immersed in fresh water. If any crack is found, apply a slight amount of sealing compound or adhesive as first-aid treatment, then call for repair.	*Do NOT use plastic solvent (thinners or acetone) for cleaning. *When removing ice on the scanner unit, use a wooden hammer or plastic-head hammer. Crack on the scanner unit will cause permanent damage to the internal circuitry due to water leakage.
	Terminal boards and plugs in scanner unit	Open scanner cover to check terminal board/plug connections inside. Also check if the rubber packing of the scanner cover is in good order.	*When putting cover back in position, do not pinch flying wires.
	CRT screen	Dirt on this creates symptom identical to poor sensitivity. Clean CRT surface using special care not to scratch it.	*Use a soft cloth with a slight amount of anti-static-charge spray. Never apply plastic solvent.

CHAPTER 4 TROUBLESHOOTING

Whenever an unusual symptom is encountered, turn off the radar and check the plug connections on p.c. boards, then proceed to individual function check along with the Trouble Finding List on the next page. If some board is found to be faulty, replace it with a new one or call for service. Do not attempt further component check in the p.c. board. Careless handling may cause more serious trouble.

"CAUTION"

There are many high tension points in the radar system. Take special care when approaching the following parts.

1. Power supply circuit (Display Unit)
2. CRT circuit (Display Unit)
3. Modulator circuit (Scanner Unit)
4. Magnetron (Scanner Unit)

Notes on Service Call

To obtain effective service, the following information should be given at a service call.

1. Name of the vessel
2. Vessel's position (port/berth)
3. Sailing Schedule
4. Radar model (Serial number/Date manufactured)
5. Symptom of trouble (Results of checks along with the Trouble Finding List)
6. Previous service

Interval	Item	Check/Measures	Remarks
6 months to 1 year	Scanner motor (See Fig.3-1.)	Check and clean carbon brushes and commutator. If brushes have worn out or abnormal spark is seen replace them with new ones.	*Under normal use, the carbon brush will last approximately 2000 hours.
	CRT anode (See Fig.3-2.)	High tension on CRT attracts dust in environment, and moist dust will cause poor insulation.	*If rubber cap is abnormally dusty or if any cracks are found on rubber cap or wire sheath, call for service. Do not try to clean or repair it for yourself, because these components are extremely delicate and high voltage may exist.
	Terminal boards, sockets and plugs	Check for loose connections. Clean contacts or replace plug, if necessary.	

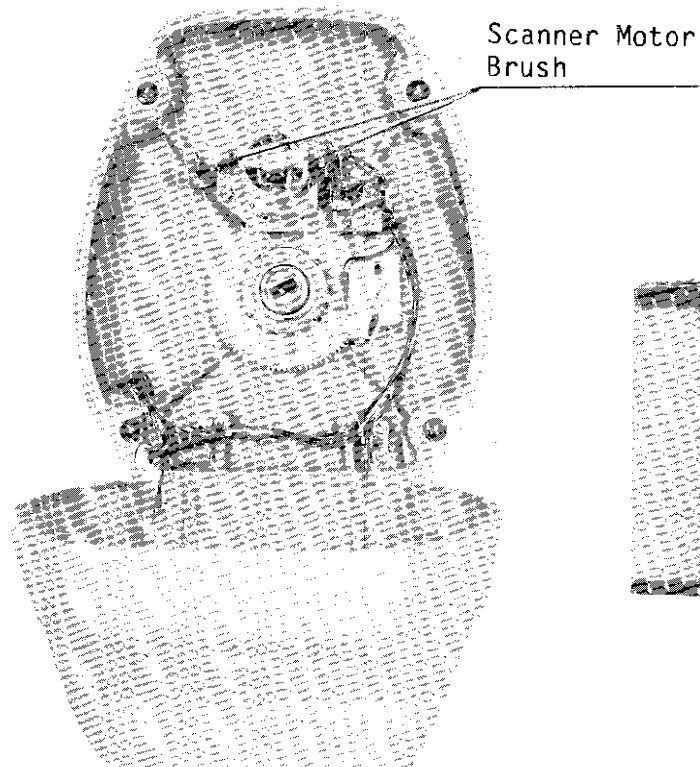

N Photo No.933

Fig.3-1

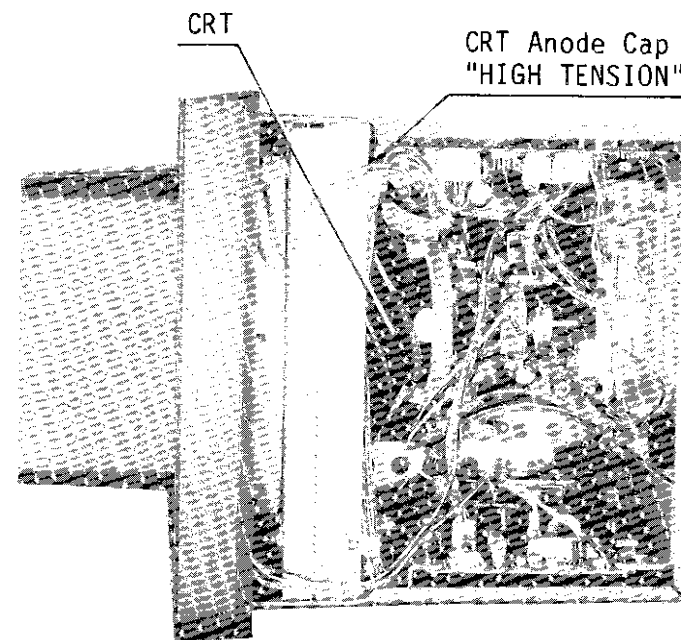

N Photo No.2107

Fig.3-2

Trouble Finding List

Operation	Symptom	Check Point	Remarks
Press POWER button.	Power is not applied to radar system. ("ON" LED above the POWER button does not light up.)	1. Main fuse F1351 (Display rear) See Fig.4-1.	*Measure mains voltage at TP301 #2(+) - #1(-). See Fig.4-2. The voltage should be between 10.2 and 40.0VDC.
		2. Mains voltage/polarity	
		3. POWER SUPPLY board (PTU-6171) See Fig.4-2.	
Antenna does not rotate.		1. Scanner rotating mechanism jammed	*Remove inner panel on display rear (Fig.4-1) and check the connection of plug P21. If it is disconnected or loosened, connect it tightly.
		2. Power supply circuit for scanner motor	
		3. Plug P21 on display rear (Fig.4-1)	
		4. Scanner motor	
Nothing appears on CRT.		1. CRT	*Visually check that CRT heater is lit.
		2. CRT H.T. (Fig.4-2)	
		3. CRT board (Fig.4-2)	*Adjust CONTRAST pot.(R7) and BRIGHT pot.(R37) on CRT board (Fig.4-2). If some picture appears, CRT assembly is OK.
		4. PROCESSOR board (Fig.4-3)	

Continued

Operation	Symptom	Check Point	Remarks
	Picture synchronization is abnormal.	1. CRT board 2. PROCESSOR board (Fig.4-3)	*Adjust vertical synchro pot.(L1) and horizontal synchro pot.(R56) on CRT board (Fig.4-2). If synchronization is not achieved, CRT board is defective.
After message ST-BY appears, press TX touchpad.	Marks and legends appear abnormally.	1. PROCESSOR board (Fig.4-3)	
Adjust GAIN control with STC set at minimum.	Marks and Legends appear but no noise nor echo.	1. IF amplifier 2. Multicore cable between display and scanner units 3. PROCESSOR board (Fig.4-3)	*Check continuity and isolation of coaxial cable. Note that coaxial cable should be disconnected at both ends before checking it with ohmmeter.
	Marks, legends and noise appear but no echo. (Transmission circuit may be faulty.)	1. PROCESSOR board (Fig.4-3) 2. Multicore cable (TX trigger line) between display and scanner units 3. Magnetron 4. Modulator circuit	*Transmit the radar on maximum range and measure magnetron current, referring to Fig.4-4. If the voltage is not within the rated value mentioned in Fig.4-4, magnetron is deteriorated.
	Sweep rotation is not synchronized with antenna rotation.	1. Bearing signal generator (Scanner unit) 2. PROCESSOR board (Fig.4-3)	

Continued

Operation	Symptom	Check Point	Remarks
Adjust TUNE control.	Poor sensitivity	1. Deteriorated magnetron	*Transmit the radar on maximum range and measure magnetron current, referring to Fig.4-4. If the voltage is not within the rated value mentioned in Fig.4-4, magnetron is deteriorated.
		2. Detuned MIC	
	Poor sensitivity (Bright circle appears on 0.25 n.m. range.)	1. Water leakage inside antenna	
Press each touchpad key	Function corresponding to the touchpad pressed is not activated.	1. Bad contact of touchpad key 2. PROCESSOR board (Fig.4-3)	
Set radar alarm zone.	Alarm zone is not produced by pressing SET/RESET touchpad. (Message ALARM does not appear.)	1. Bad contact of touchpad key 2. ATI board (Fig.4-2) 3. PROCESSOR board (Fig.4-3)	
	Alarm zone appears but no alarm sound. (Message ALARM appears on CRT.)	1. Buzzer 2. ATI board (Fig.4-2)	

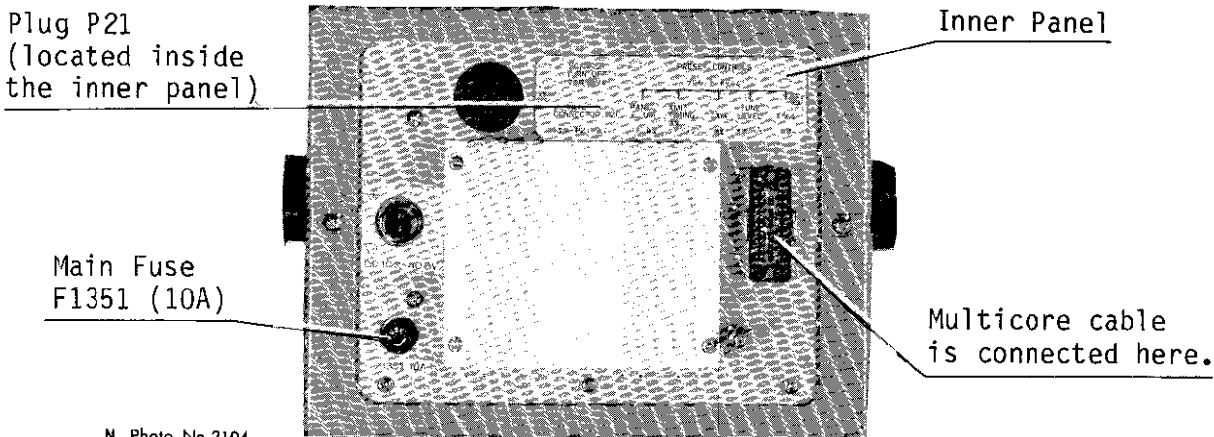

N Photo No.2104

Fig.4-1 Display Unit, Rear View

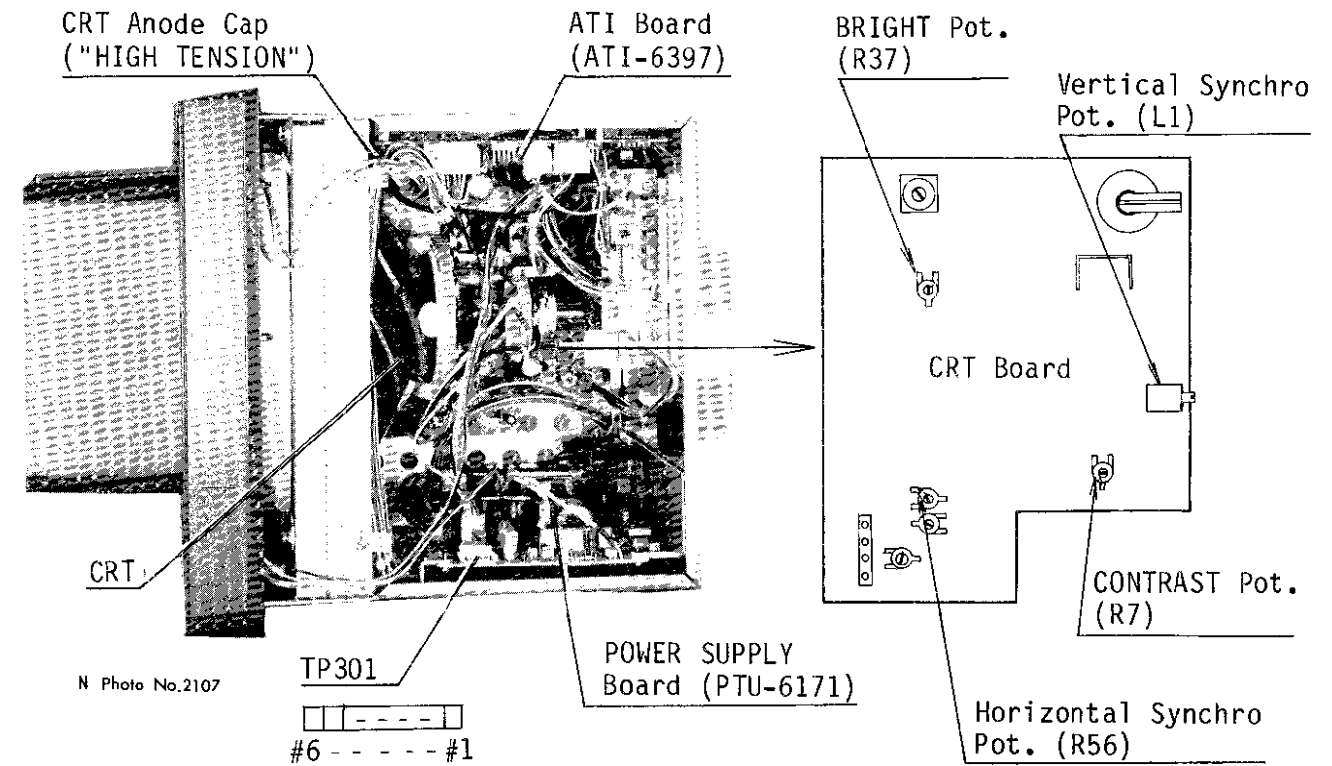

Fig.4-2 Display Unit, Top View (Cover removed)

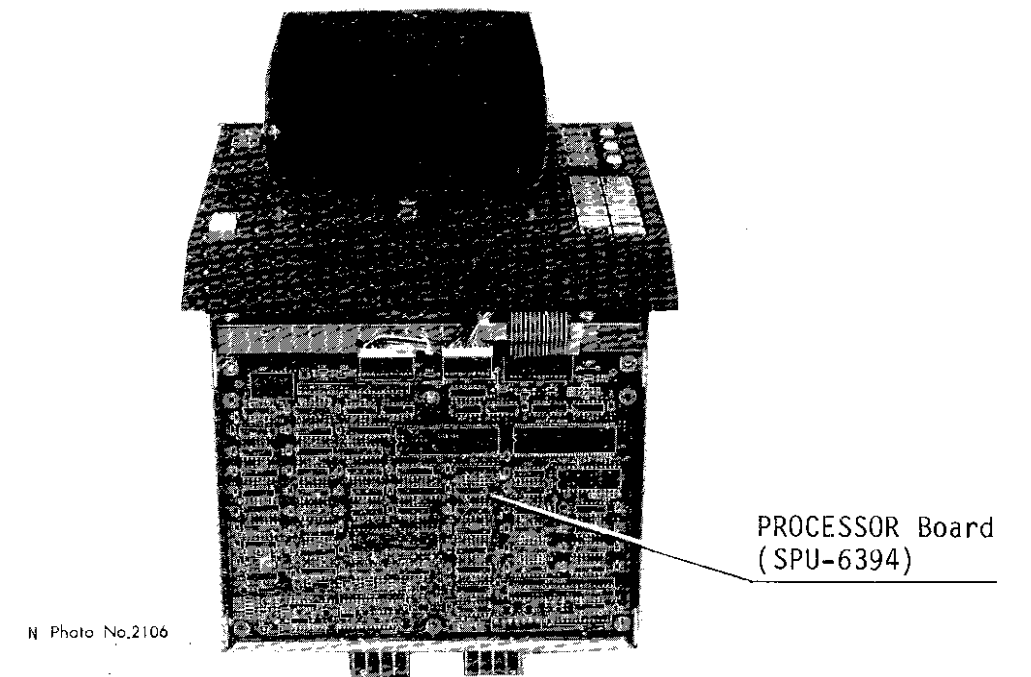
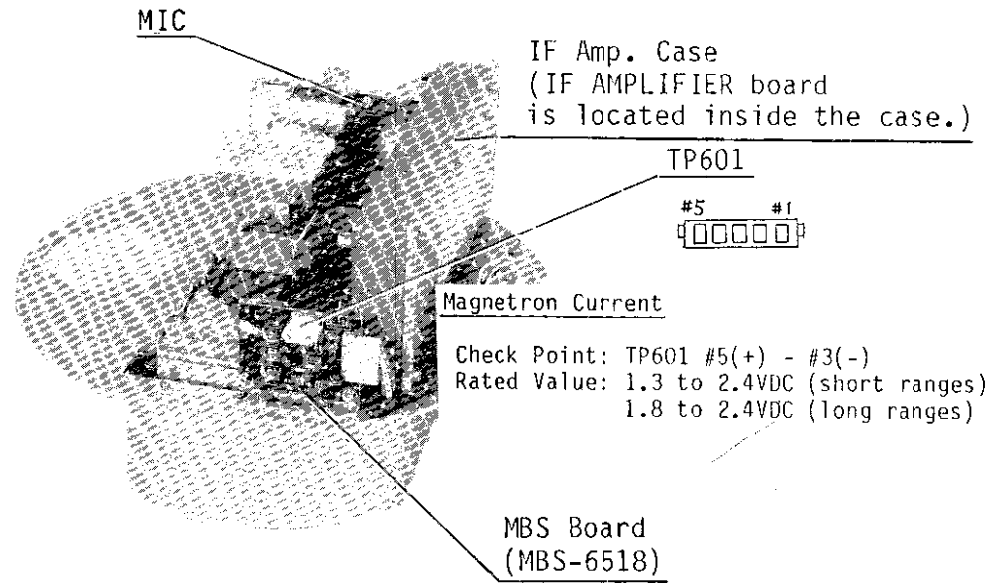

Fig.4-3 Display Unit



N Photo No.2256

Fig.4-4 Transceiver Module

CONTENTS OF SCHEMATIC DIAGRAMS

No.	Name	Type	Drawing No.	Page
1	DISPLAY UNIT		C3292-015	S-1
2	ATI BOARD	ATI-6397	C3292-022	S-2
3	PRESET CONTROL BOARD	ADJ-6398	C3292-025	S-3
4	CRT DISPLAY	A1QA9DSP41	C3289-016	S-4
5	POWER SUPPLY BOARD	PTU-6171	C3289-008	S-5
6	SCANNER UNIT		C3306-006	S-6
7	IF AMPLIFIER	IF-6515	C3292-021	S-7
8	INTERCONNECTION DIAGRAM		C3292-014	S-8

CONTENTS OF OUTLINE DRAWINGS

No.	Name	Type	Drawing No.	Page
1	SCANNER UNIT		C3306-002	D-1
2	DISPLAY UNIT		C3292-018	D-2
3	RECTIFIER	RU-3423	C3002-005	D-3

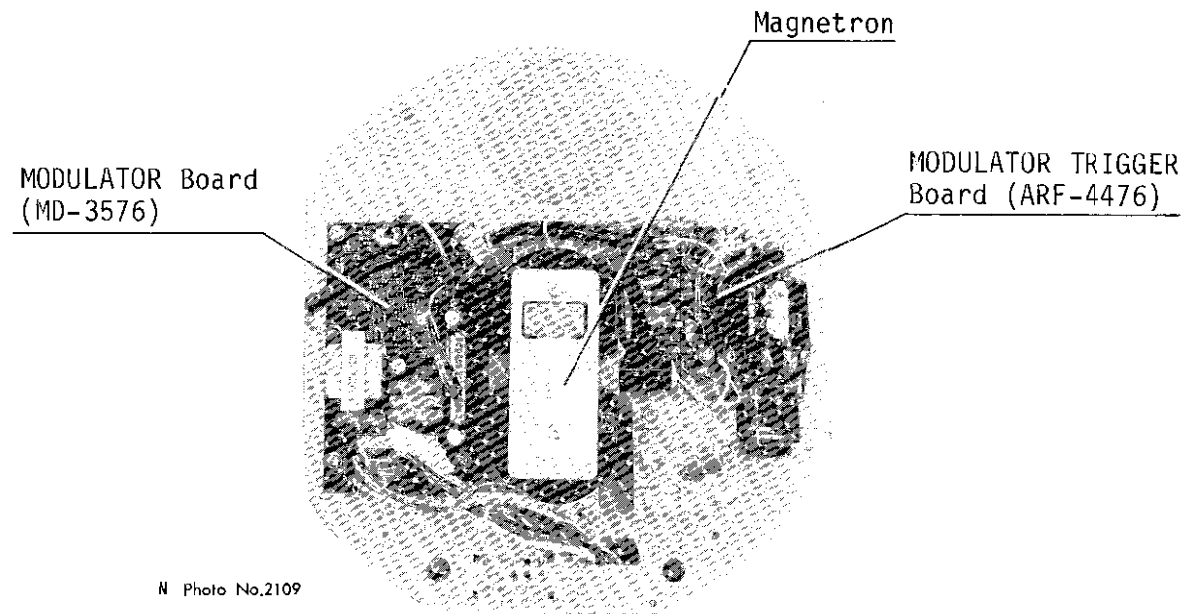

N Photo No.2109

Fig.4-5 Transceiver Module, Bottom View (Shield Cover removed)

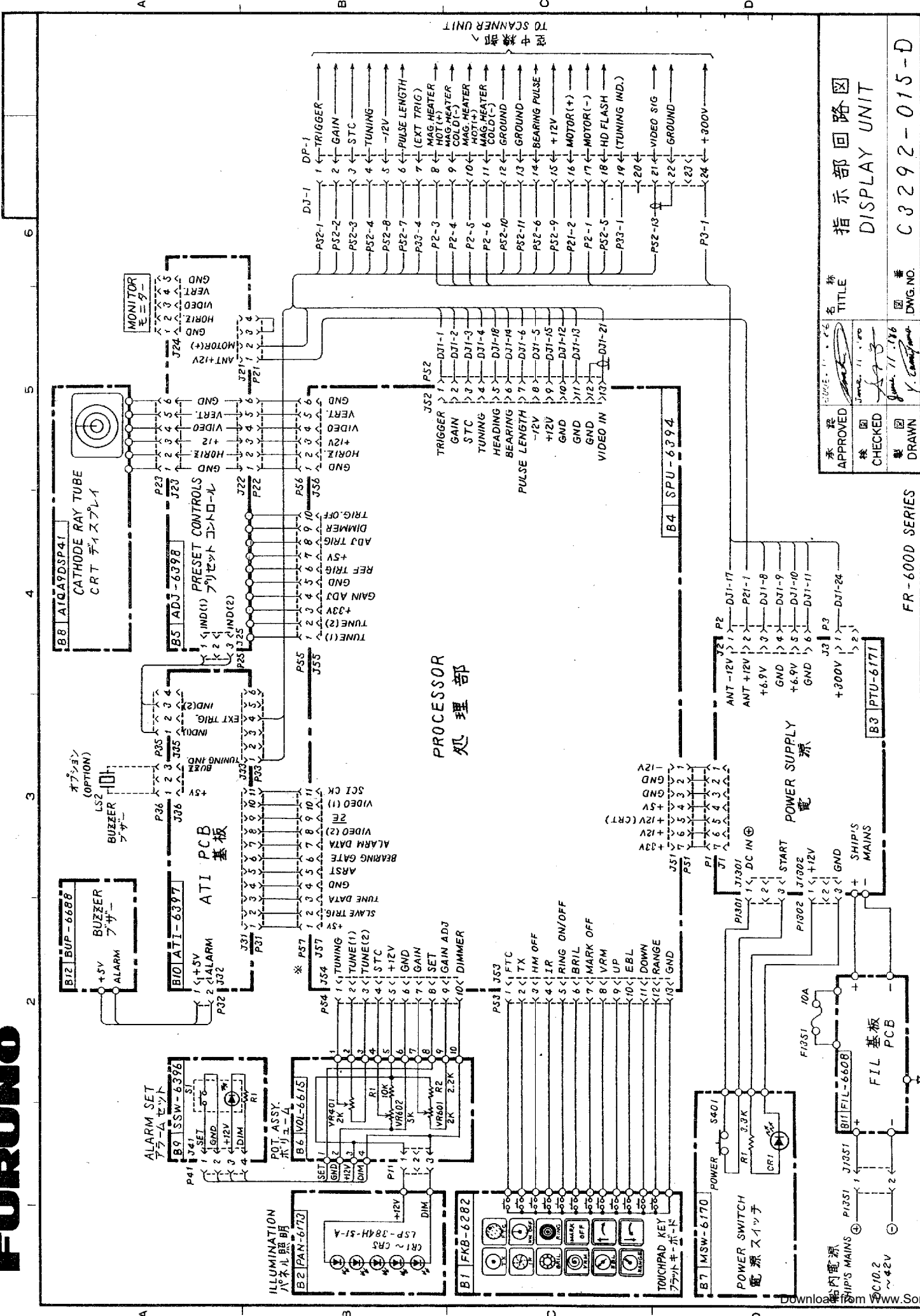

承認
APPROVED
検図
CHECKED
製図
DRAWN
名 称
TITLE
指示部回路図
DISPLAY UNIT
図 番
DWG. NO.
C3292-015-D
FR-600 SERIES
FURUNO ELECTRIC CO., LTD.

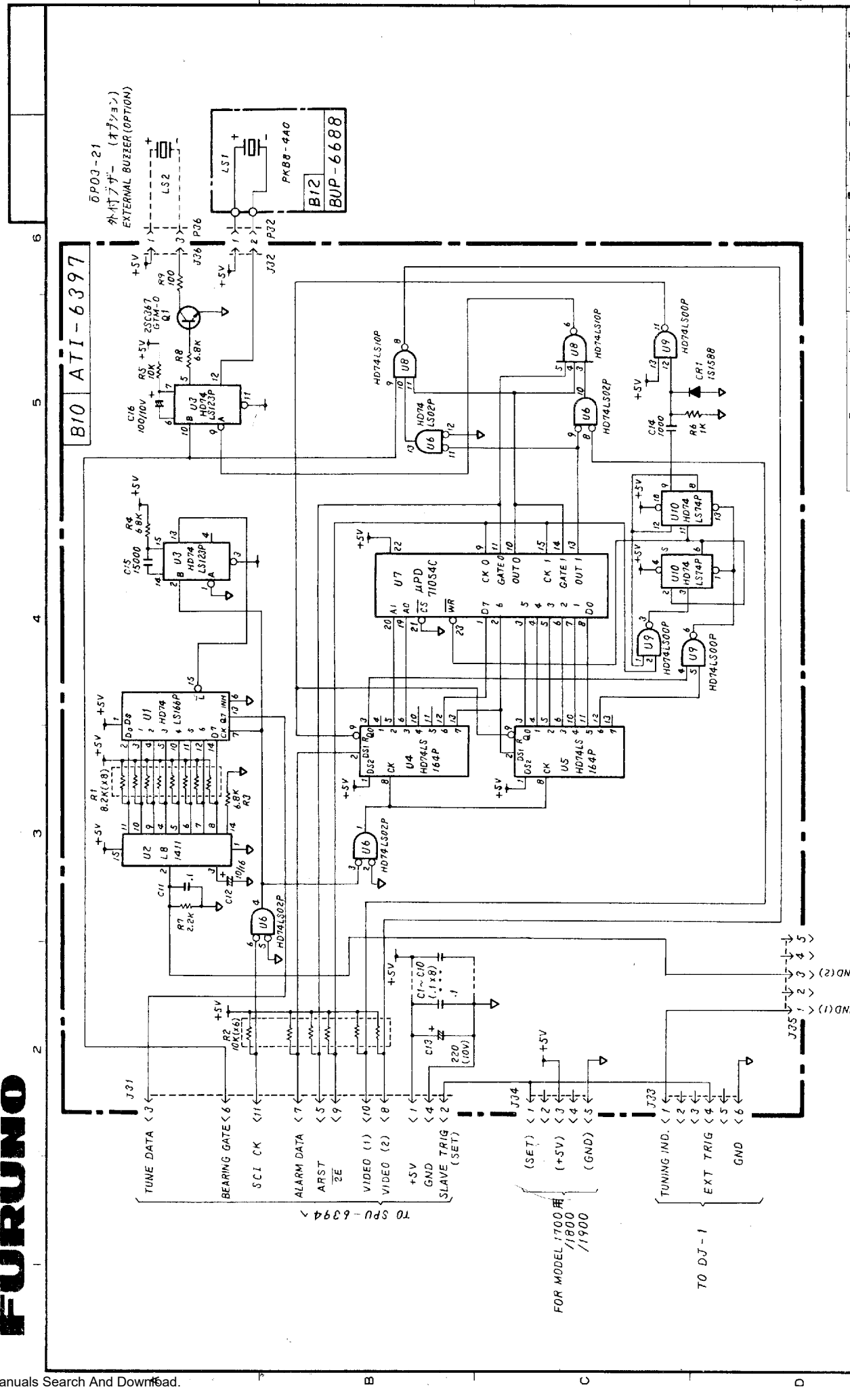

承認
APPROVED
検図
CHECKED
製図
DRAWN
名 称
TITLE
ATI基板回路図
ALARM/TUNING BOARD
図 番
DWG. NO.
C3292-022-A
FR-601D
FR-602D
FR-603D
FR-604D
FURUNO ELECTRIC CO., LTD.

NOTE 1. 特記なき抵抗の単位は全て、1/4W エンコンデンサはμF.
ALL RESISTANCE IN OHMS, 1/4W AND CAPACITANCE IN MICROFARADS UNLESS NOTED OTHERWISE.

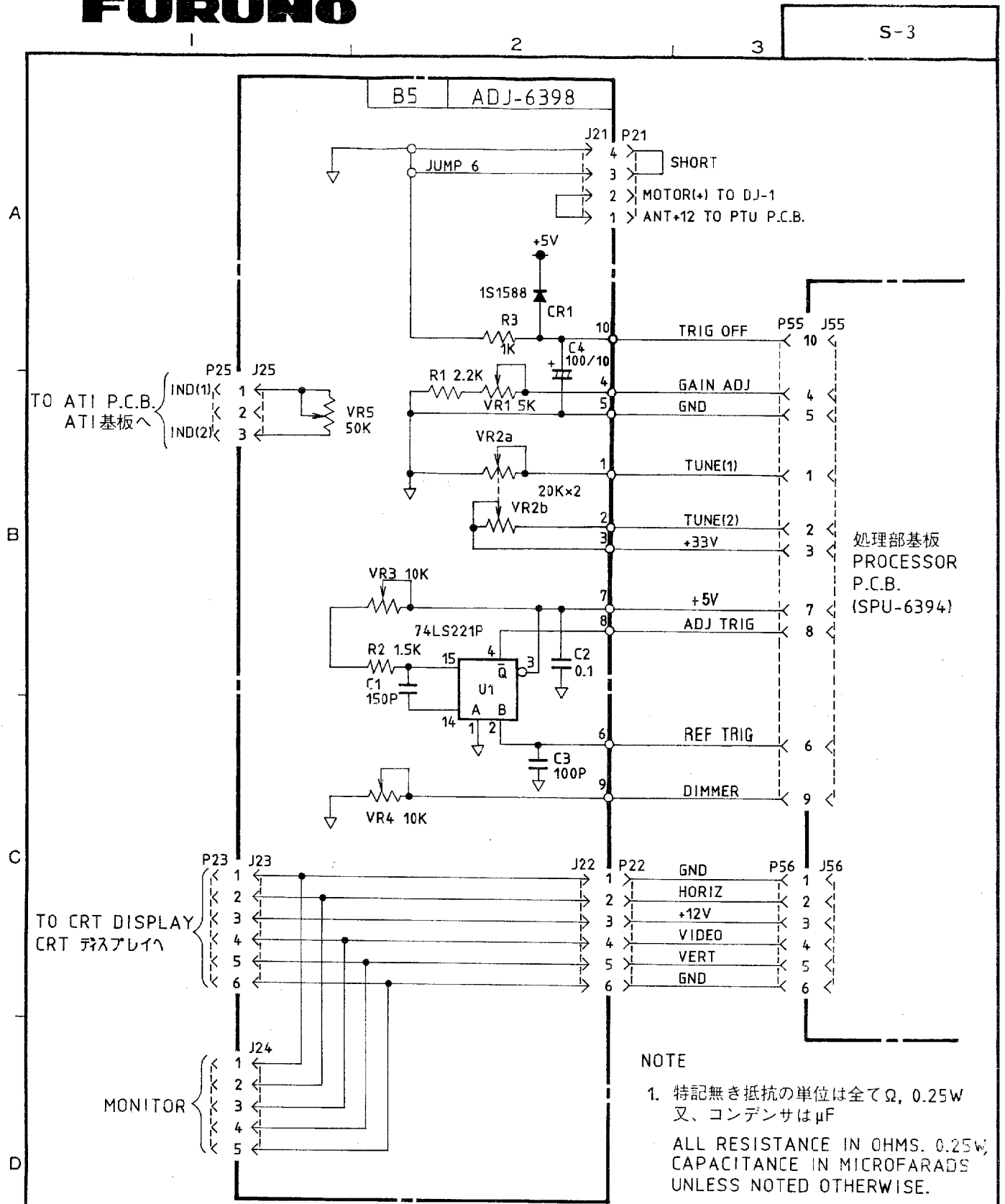

NOTE
 1. 特記無き抵抗の単位は全てΩ, 0.25W
 又、コンデンサはμF
 ALL RESISTANCE IN OHMS. 0.25W,
 CAPACITANCE IN MICROFARADS
 UNLESS NOTED OTHERWISE.

FR-600D SERIES
 MODEL-1800/1900

承認 APPROVED	NOV. 17 '86 T. MAKINO	名称 TITLE	ADJ-6398 プリセットコントロール PRESET CONTROLS
検 CHECKED	NOV. 17 '86 I. Amano	図番 DWG. NO.	C3292-025-B
製 DRAWN	NOV. 17 '86 Y. Tomiyama		

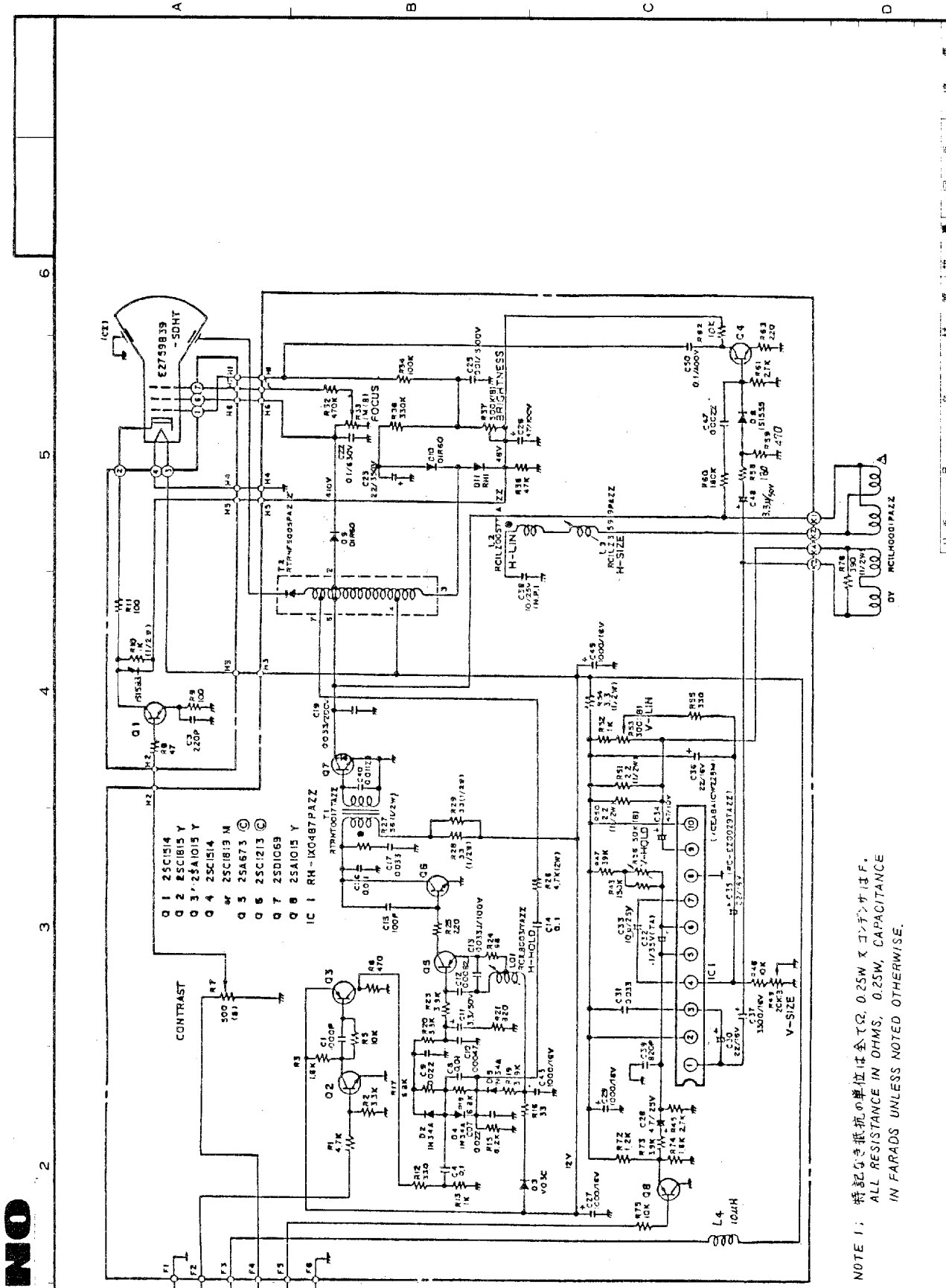

NOTE 1: 特記なき抵抗の単位は全てΩ, 0.25W X コンデンサはF.
 ALL RESISTANCE IN OHMS, 0.25W, CAPACITANCE
 IN FARADS UNLESS NOTED OTHERWISE.

承認 APPROVED	NOV. 17 '86 T. MAKINO	名称 TITLE	表示部 CRT DISPLAY
検 CHECKED	NOV. 17 '86 I. Amano	図番 DWG. NO.	C3289-016-A
製 DRAWN	NOV. 17 '86 Y. Tomiyama		

Model 1700/1800/1900
 FR-600D Series

電源スイッチ基板へ
TO POWER SWITCH BOARD MSW-6170

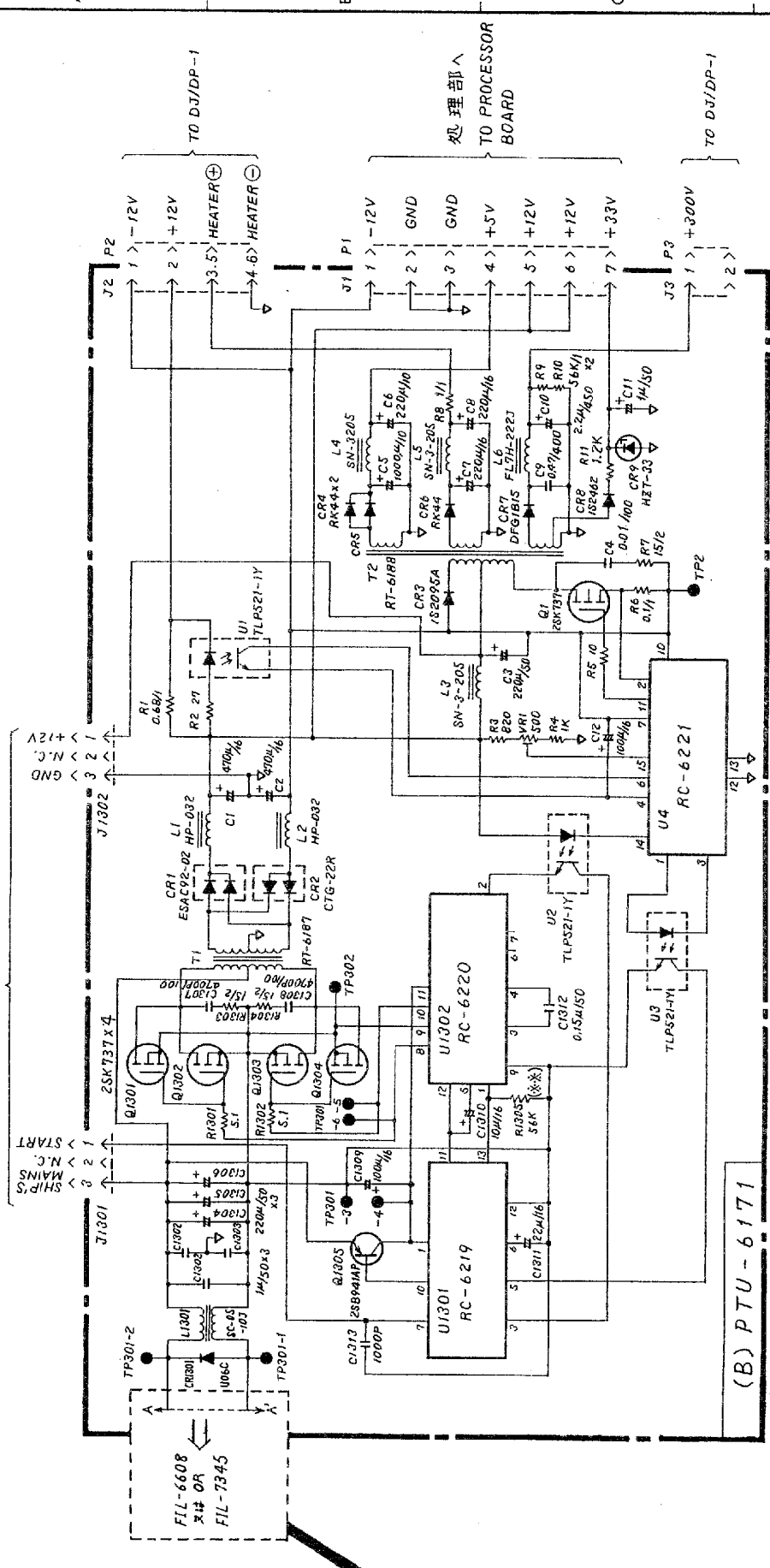

(B) PTU-6171

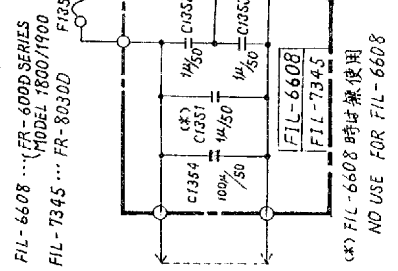

船内電源
SHIPS MAINS
2 ~ 40VDC

FIL-6608 (FR-6000 SERIES MODEL 1800/1900)
FIL-7345 (FR-8030D F1351 10A)

(*) FIL-6608 時は兼使用
NO USE FOR FIL-6608

NOTE 1. 特記無き抵抗の単位は全 Ω , 1/4W X コンテンサは μ F.
ALL RESISTANCE IN OHMS, 1/4W AND CAPACITANCE IN MICROFARADS UNLESS NOTED OTHERWISE.
2. (参考) R1305はMODEL 1700では採用されない。
R1305 IS NOT USED FOR MODEL 1700.

承認 APPROVED	検査 CHECKED	製図 DRAWN	訂正 REV.	品番 ITEM	品名 NAME	材質 MATERIAL	数量 QTY	図番 DWG. NO.	備考 REMARKS
○	○	○	1/85	PTU-6171	電源部 POWER SUPPLY			C3289-008-J	

REV.: 1/85

FURUNO ELECTRIC CO., LTD

送受信シャシー
TRANSCIVER MODULE

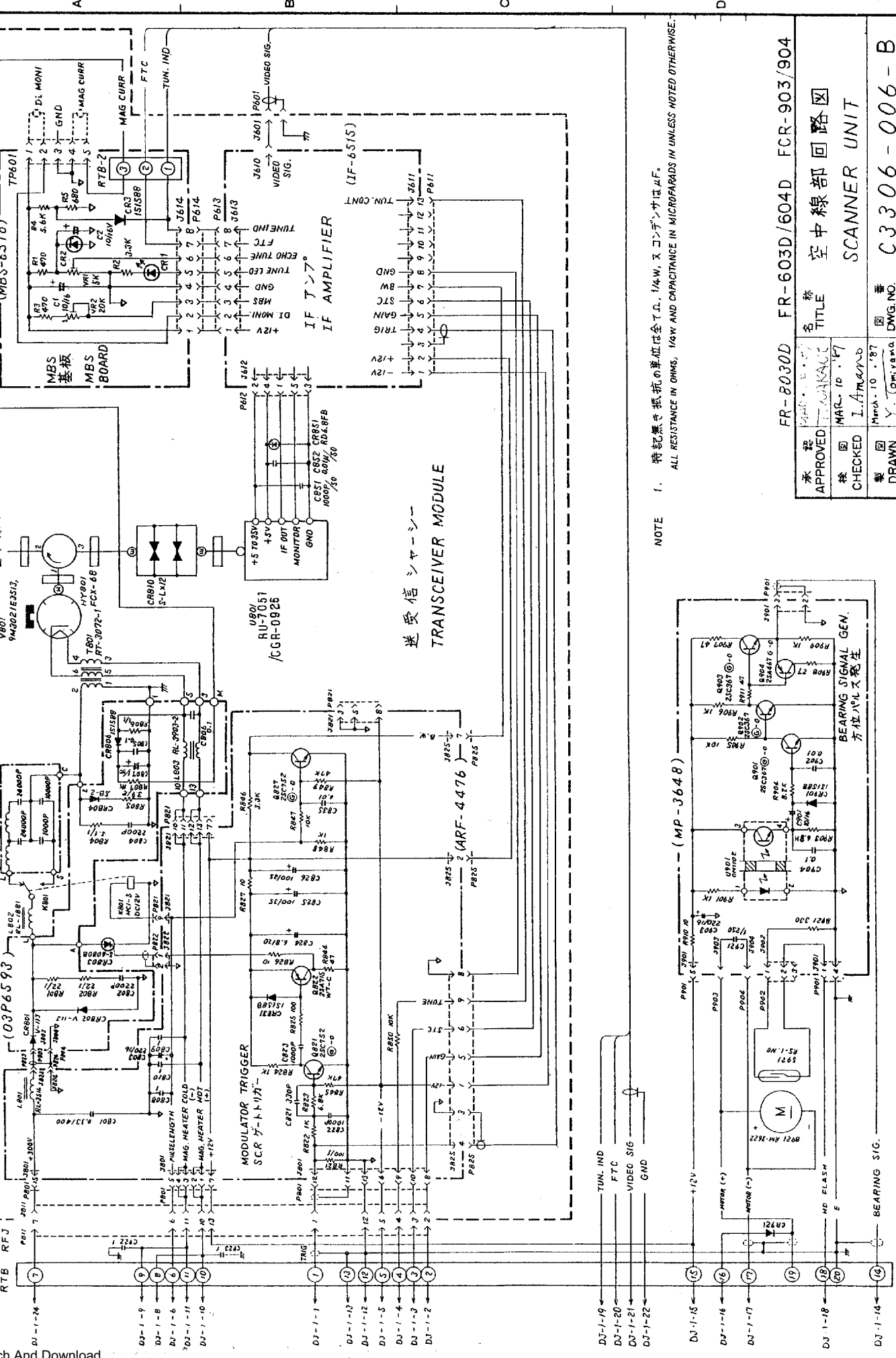

NOTE 1. 特記無き抵抗の単位は全 Ω , 1/4W, X コンテンサは μ F.
ALL RESISTANCE IN OHMS, 1/4W AND CAPACITANCE IN MICROFARADS IN UNLESS NOTED OTHERWISE.

承認 APPROVED	検査 CHECKED	製図 DRAWN	品番 ITEM	品名 NAME	材質 MATERIAL	数量 QTY	図番 DWG. NO.	備考 REMARKS
○	○	○	FR-8030D	空中線部回路 SCANNER UNIT			C3306-006-B	

FURUNO ELECTRIC CO., LTD.

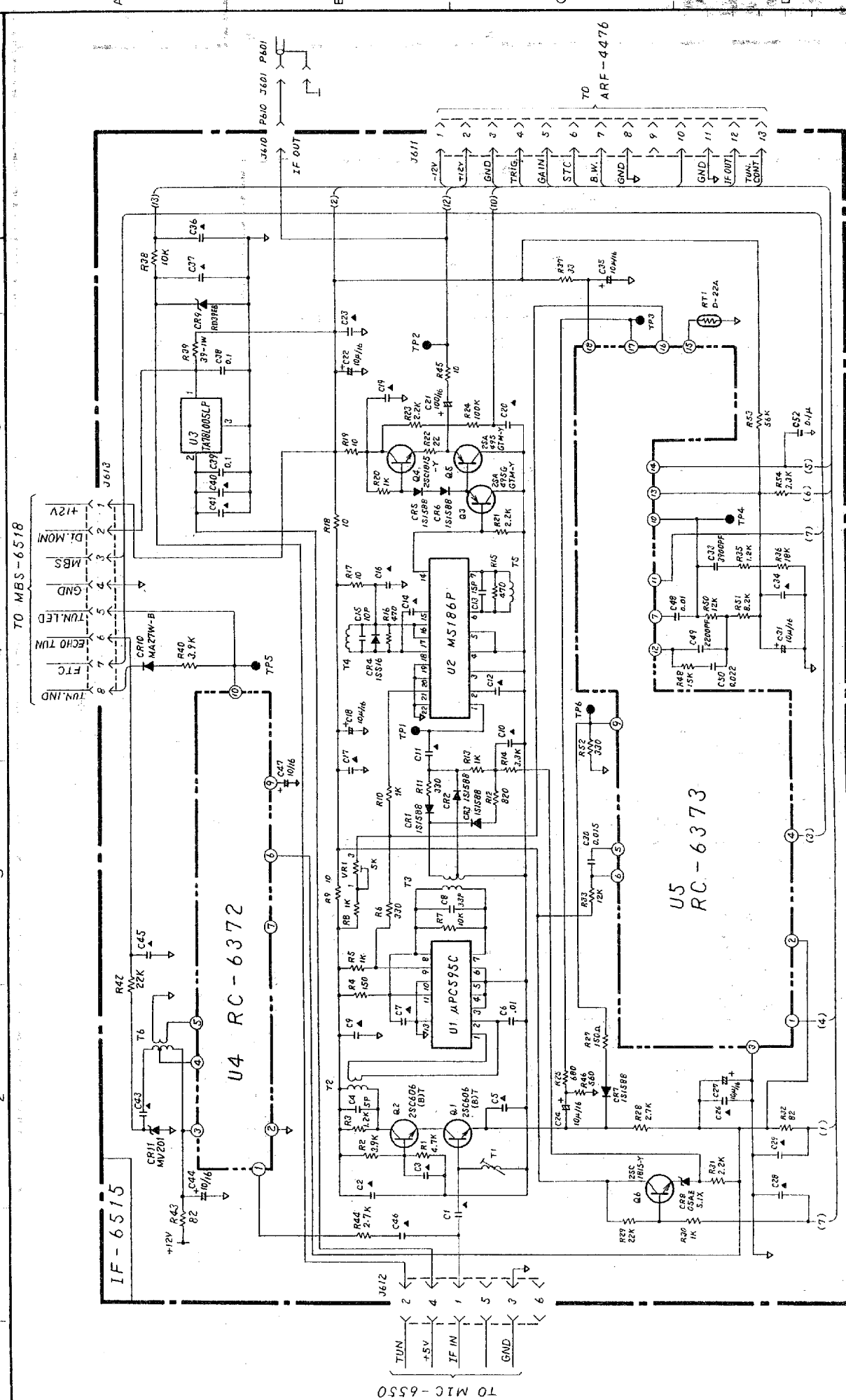

承認済
 検図
 製図
 APPROVED
 CHECKED
 DRAWN
 TITLE
 IF-6515 IF AMPLIFIER
 DWG. NO. C3292-021-C
 MODEL 1900, FR-603D/604D

- ▲印のコンデンサは 1000PF/50V.
▲ MARKED CAPACITANCE IN 1000 PICOFARADS, 50 VOLT.
- ※記無き抵抗の単位は全てΩ, 0.25W, スコンデンサはF.
ALL RESISTANCE IN OHMS, AND CAPACITANCE IN FARADS
UNLESS NOTED OTHERWISE.

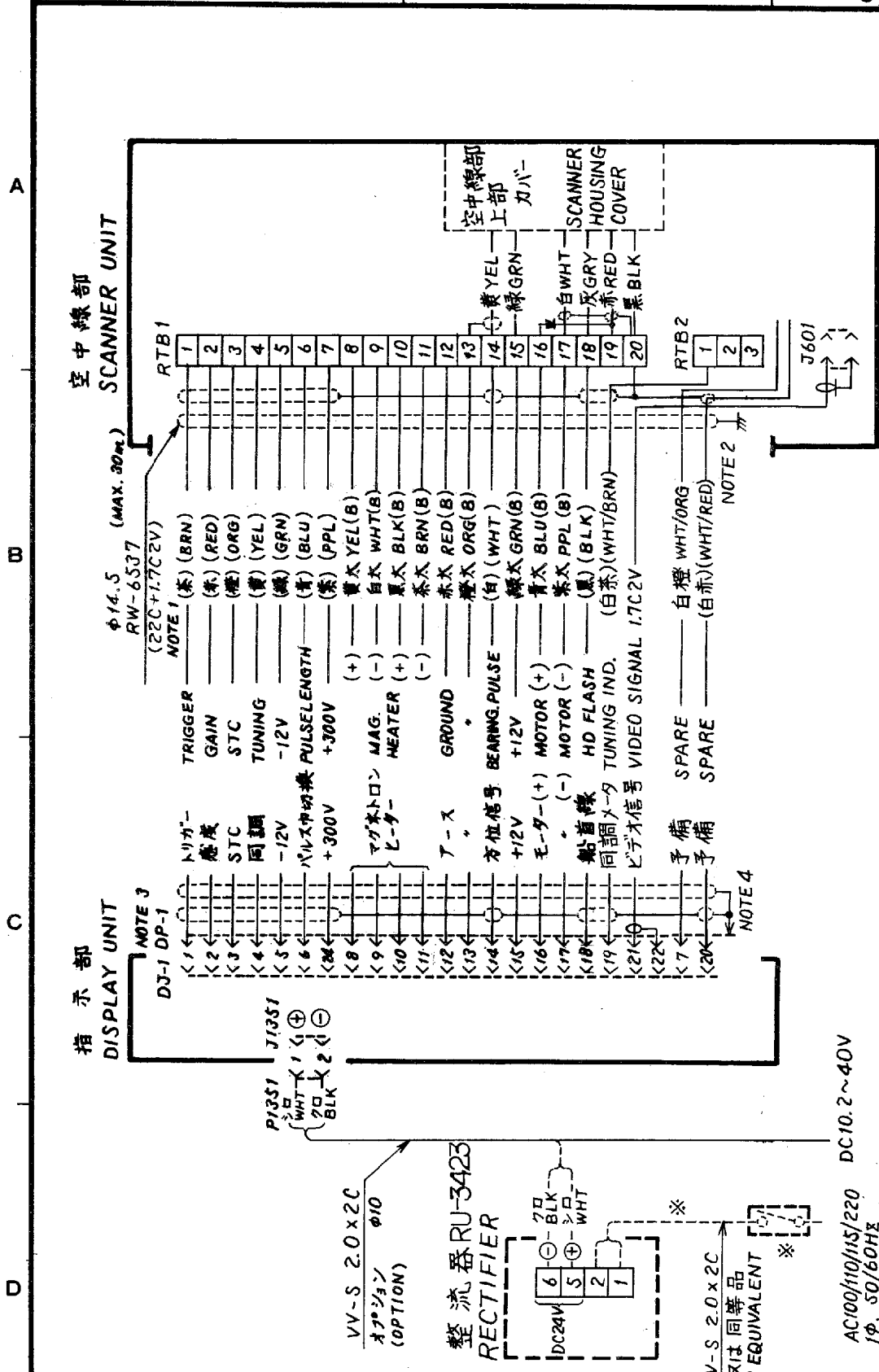

- NOTE: 1. ケーブルのカラーコードで()は内側ケーブルを示す。
 WIRE COLOR CODE () : INNER WIRES, (B) : BIG WIRES.
 2. 空中線部ケーブルのシールドは完全にアースすること。
 SHIELD SHOULD BE EFFECTIVELY GROUNDED AT SCANNER UNIT.
 3. コネクタはコネクタ専用付添。コネクタプラグは工場製。
 CONNECTOR PLUGS FACTORY-WIRED.
 4. シールドはコネクタケースを通してアースされている。
 SHIELD GROUNDED THRU CONNECTOR CASE.
 5. ※ 造船所供給 SHIPYARD SUPPLY.

承認 APPROVED	検図 CHECKED	製図 DRAWN	品番 ITEM	品名 NAME	材質 MATERIAL	数量 Q'TY	図番 DWG. NO.	摘要 REMARKS
JUL. 12. '86	June. 12. '86	June. 12. '86	FR-603D/604D	相互結線図 INTERCONNECTION DIAGRAM			C3292-014-D	
			THIRD ANGLE PROJECTION				各務 TITLE	
			尺 度 SCALE				船内電源 SHIP'S MAINS	
			重 量 WEIGHT				DC10.2~40V 1φ, 50/60HZ	

FURUNO

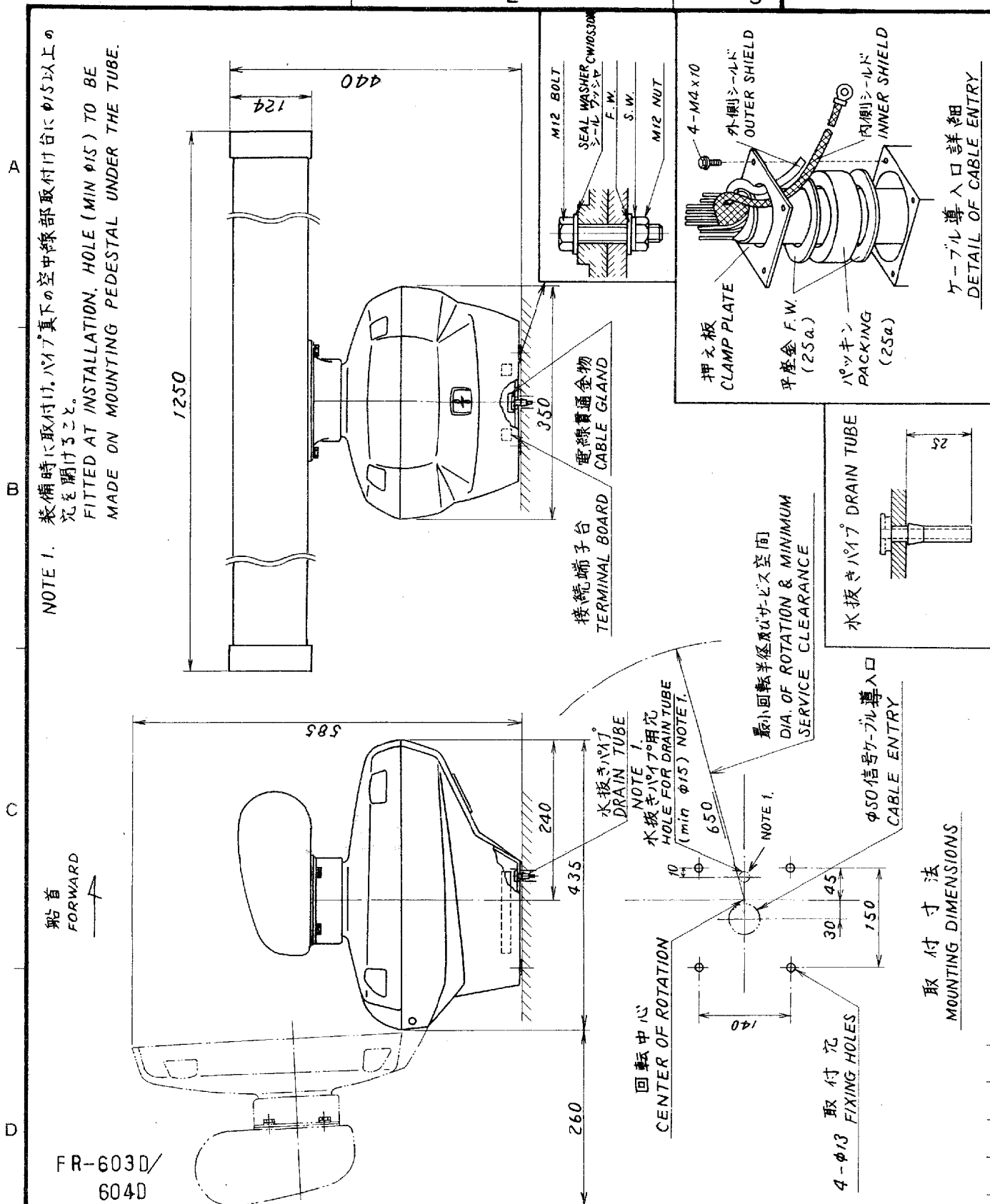

NOTE 1. 装備時に取付け、パイプ真下の空中線部取付け台にφ15以上の穴を開けること。
FITTED AT INSTALLATION. HOLE (MIN φ15) TO BE MADE ON MOUNTING PEDESTAL UNDER THE TUBE.

NOTE 1. 水抜きパイプの取付穴 (min φ15) 参照。
DIA. OF ROTATION & MINIMUM SERVICE CLEARANCE

取付寸法
MOUNTING DIMENSIONS

FR-603D/
604D
FCR-903/904
FR-8030D

品番 ITEM	品名 NAME	材質 MATERIAL	数量 Q'TY	図番 DWG.NO.	摘要 REMARKS
承認 APPROVED	FEB. 2 '87 T. NAKANO	三角法 THIRD ANGLE PROJECTION		名称 TITLE	RSB-0024-XN12A レーダー空中線部寸法図 RADAR SCANNER UNIT
検図 CHECKED	FEB. 2 '87 I. Amano	尺度 SCALE	1/8	重量 WEIGHT	23 kg
製図 DRAWN	FEB. 2 '86 Y. Tomiyama			図番 DWG.NO.	C3306-002-C

FURUNO

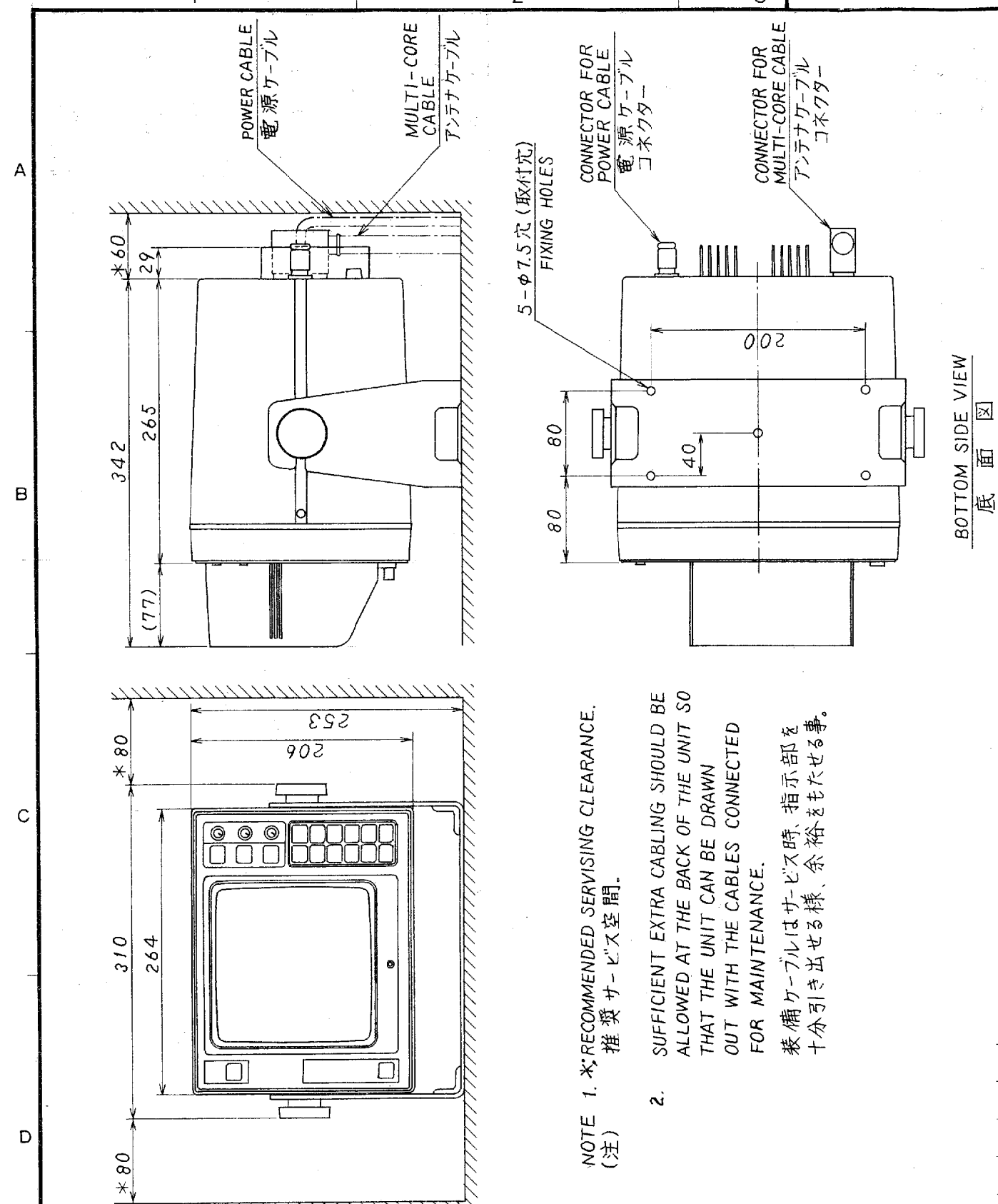

NOTE 1. *RECOMMENDED SERVICING CLEARANCE.
(注) 推奨サービス空間。
2. SUFFICIENT EXTRA CABLING SHOULD BE ALLOWED AT THE BACK OF THE UNIT SO THAT THE UNIT CAN BE DRAWN OUT WITH THE CABLES CONNECTED FOR MAINTENANCE.
装備ケーブルはサービス時、指示部を十分引き出せる様、余裕をたせる事。

品番 ITEM	品名 NAME	材質 MATERIAL	数量 Q'TY	図番 DWG.NO.	摘要 REMARKS
承認 APPROVED	JUNE. 16 '86 M. Nishimura	三角法 THIRD ANGLE PROJECTION		名称 TITLE	RADAR DISPLAY UNIT レーダー指示部外寸図
検図 CHECKED	JUNE. 16 '86 S. Sato	尺度 SCALE	1/5	重量 WEIGHT	6.9 kg
製図 DRAWN	JUNE. 13 '86 M. Tomiyama			図番 DWG.NO.	C3292-018-A

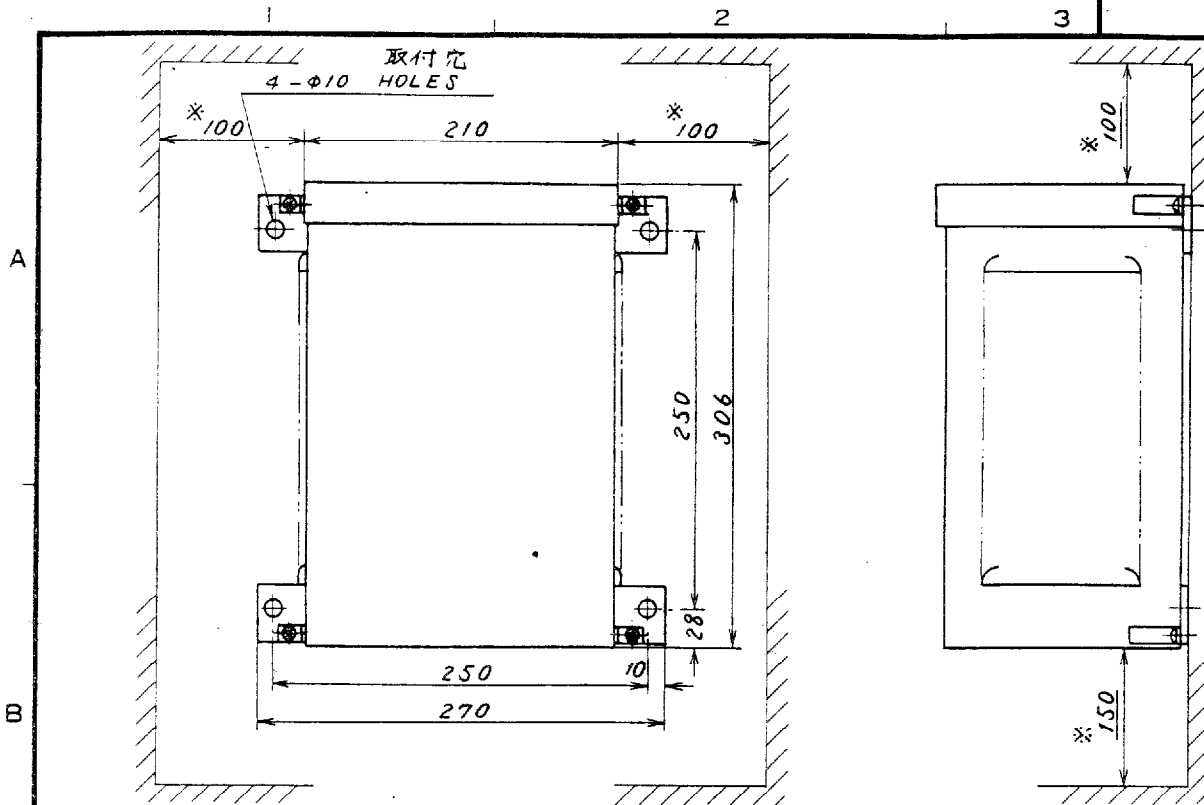

NOTE 1. ※: 推奨サービス空間.
RECOMMENDED SERVICING CLEARANCE.

2. コンパス安全距離
COMPASS SAFE DISTANCE.

スタンダード STANDARD	2.1M
ステアリング STEERING	1.5M

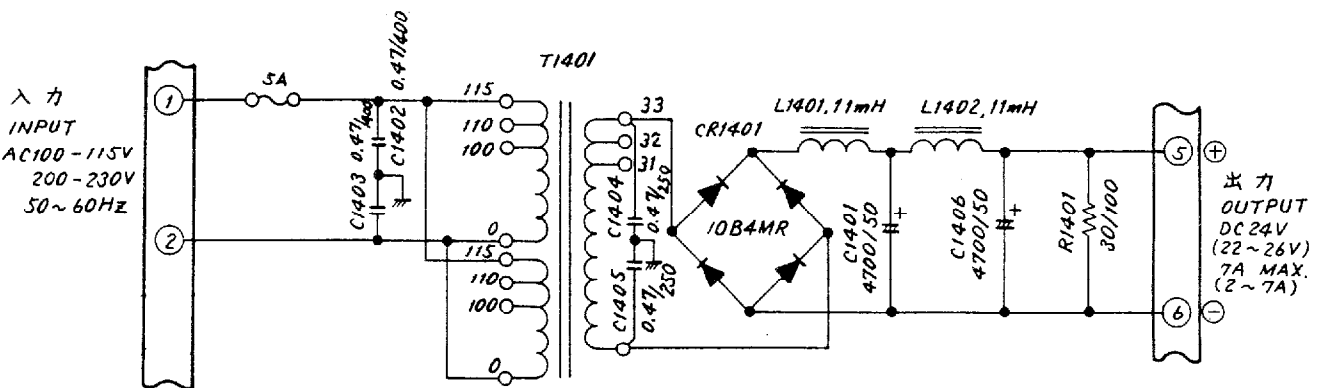

注 AC220V入力に対してはT1401の一次巻線を直列に接続する。

NOTE FOR 220VAC INPUT, CONNECT T1401 PRIMARY WINDINGS IN SERIES.

品番 ITEM	品名 NAME	材質 MATERIAL	数量 Q'TY	図番 DWG. NO.	摘要 REMARKS
承認 APPROVED	三角法 THIRD ANGLE PROJECTION	名称 TITLE RU-3423 整流器 RECTIFIER UNIT			
検査 CHECKED	尺度 SCALE 1/5				
製 DRAWN	重量 WEIGHT 16.5kg	図番 DWG. NO. C3002-005-H			

REV.: 8/85

Free Manuals Download Website

<http://myh66.com>

<http://usermanuals.us>

<http://www.somanuals.com>

<http://www.4manuals.cc>

<http://www.manual-lib.com>

<http://www.404manual.com>

<http://www.luxmanual.com>

<http://aubethermostatmanual.com>

Golf course search by state

<http://golfingnear.com>

Email search by domain

<http://emailbydomain.com>

Auto manuals search

<http://auto.somanuals.com>

TV manuals search

<http://tv.somanuals.com>