

FURUNO

INSTALLATION MANUAL

MARINE RADAR

MODEL FR-2130S



FURUNO ELECTRIC CO., LTD.
NISHINOMIYA, JAPAN

©FURUNO ELECTRIC CO., LTD.

9-52, Ashihara-cho,
Nishinomiya, Japan 662

Telephone: 0798-65-2111
Telefax: 0798-65-4200

-Your Local Agent/Dealer

All rights reserved. Printed in Japan

FIRST EDITION : MAY 1994
D : FEB. 16, 1998

(CHINA)

PUB. No. IME-33870-D
FR-2130S





SAFETY INSTRUCTIONS



DANGER



Do not work inside the equipment unless totally familiar with electrical circuits.

Hazardous voltage which will cause death or serious injury exists inside the equipment.



WARNING

Radio Frequency Radiation Hazard

The radar antenna emits electromagnetic radio frequency (RF) energy which can be harmful, particularly to your eyes. Never look directly into the antenna aperture from a close distance while the radar is in operation or expose yourself to the transmitting antenna at a close distance.

Distances at which RF radiation levels of 100 and 10 W/m² exist are given in the table below.

Note: If the antenna unit is installed at a close distance in front of the wheel house, your administration may require halt of transmission within a certain sector of antenna revolution. This is possible—Ask your FURUNO representative or dealer to provide this feature.

Model	Radiator type	Distance to 100 W point	Distance to 10 W point	RF power density on antenna aperture
FR-2015-I (X-band, 10 kW)	XN2 (4')	Worst case 0.25 m*	Worst case 2.3 m*	11.0 W/m ²
	XN3 (6.5')			9.6 W/m ²
	XN3A (6.5')			9.6 W/m ²
	XN4A (8')			6.7 W/m ²
FR-2025-I/2025W-I (X-band, 25 kW)	XN2** (4')	Worst case 0.6 m*	Worst case 3.25 m*	29.0 W/m ²
	XN3** (6.5')			23.8 W/m ²
	XN3A (6.5')			23.8 W/m ²
	XN4A (8')			20.6 W/m ²
FR-2130S (S-band, 30 kW)	SN5AF (9')	Nil	1.06 m	20.0 W/m ²
	SN7AF (12')	Nil	0.5 m	16.0 W/m ²

*UK DRA measured on FR-2810/2820 with NARDA 8616. Other values by FURUNO.

** XN2 and XN3 are not applicable to FR-2025W-I.



WARNING



Turn off the radar power switch before servicing the antenna unit. Post a warning sign near the switch indicating it should not be turned on while the antenna unit is being serviced.

Prevent the potential risk of being struck by the rotating antenna and exposure to RF radiation hazard.



Wear a safety belt and hard hat when working on the antenna unit.

Serious injury or death can result if someone falls from the radar antenna mast.



Turn off the power at the mains switchboard before beginning the installation. Post a sign near the switch to indicate it should not be turned on while the equipment is being installed.

Fire, electrical shock or serious injury can result if the power is left on or is applied while the equipment is being installed.



CAUTION



Ground the equipment to prevent electrical shock and mutual interference.

Confirm that the power supply voltage is compatible with the voltage rating of the equipment.

Connection to the wrong power supply can cause fire or equipment damage. The voltage rating appears on the label at the rear of the display unit.

Use the correct fuse.

Use of a wrong fuse can cause fire or equipment damage.

IMPORTANT

Settings According to Class and Flag of Vessel

Overview

A DIP switch and a menu setting enable the setting up of this radar according to class and flag of vessel. Be sure to set them accordingly.

Merchant vessel or fishing vessel

The menus differ between merchant and fishing vessels. The menu type is set by DIP switch S1 #2 on the SPU Board SPU-9111.

DIP Switch	Merchant Vessel	Fishing Vessel
S1 #2	OFF	ON

Vessel's flag

The specifications for radars differ among nations. The specifications are set on the INITIAL SETTING 2 menu.

INITIAL SETTING 2 menu	IMO Vessel	Non-IMO Vessel
3 N SPEC	ON	OFF

TABLE OF CONTENTS

INSTALLATION	1-1
GENERAL	1-1
SCANNER UNIT	1-2
DISPLAY UNIT	1-7
POWER SUPPLY UNIT	1-8
WIRING	2-1
DISPLAY UNIT	2-1
SCANNER UNIT	2-5
POWER SUPPLY UNIT	2-10
INITIALIZATION AND ADJUSTMENT	3-1
Setting Supply Voltage/Frequency	3-2
Selection of Vessel Class	3-3
Setting Function Keys	3-4
Adjustment of Video Amplifier Level	3-5
Suppression of Main Bang	3-6
Adjustment of Tuning	3-7
Initialization	3-8
Adjustment of Magnetron Heater Voltage	3-13
Adjustment of Sweep Timing	3-14
Alignment of Heading	3-15
Adjustment Check List	3-16
Appendix A-INITIALIZATION OF GYRO CONVERTER GC-8	A-1
Connection of External Power Spplly	A-2
Setting of DIP Switches and Jumper Wires	A-3
Setting of Bearing	A-10
Appendix B-INSTALLING GYRO CONVERTER GC-8	B-1
TABLE OF DRAWINGS	D-0
Outline Drawings	D-1
Interconnection Drawings	S-1
Circuit Diagrams	S-4

UNIT INSTALLATION

GENERAL

This radar system is mainly composed of three units, the display unit, Power Supply Unit, the scanner unit.

Installation of the radar consists of siting and mounting the units and running the interconnecting cables and the power cable.

The compass safe distance, the minimum distance a magnetic compass should be separated from a radar unit so that it will not be affected by the magnetic fields generated by the radar.

Unit	Std. Compass	Steering Compass
Scanner Unit	4.3m	2.6m
Display Unit	1.2m	0.9m
Power Supply Unit	0.7m	0.5m

Before beginning the installation, check that there are no missing parts by referring to the parts lists. All steel and wood works should be arranged locally.

SCANNER UNIT

Siting

The scanner unit is generally installed on the top of the wheelhouse or on an appropriate platform on the radar mast. When siting the unit, consideration must be given to the following points.

- 1) The maximum length of the signal cable RW-6895 and the antenna cable MPYCY-16 is 100 meters (no splice is allowed).
- 2) A funnel, mast or derrick post in line of sight of the radiator may cause blind sectors on the radar picture. A shadow sector between 355 and 5 degrees must be avoided by carefully planning the installation site.
- 3) Deposits and fumes from the funnel or other exhaust vent can adversely affect the aerial performance and hot gas tends to distort the radiator portion. The scanner unit must not be mounted in a place where it may be subjected to temperature in excess of 70 °C .
- 4) The unit must not be positioned in close proximity to a direction finder (DF) aerial; separation of more than 2 meters is recommended.
- 5) The scanner unit is normally mounted with the cable gland facing the ship's stern, however the cable gland can be faced toward port or starboard as well. In this case, the synchronous gear magnet (see below), which produces the heading signal, should be remounted. Fix the magnet according to cable gland attitude.

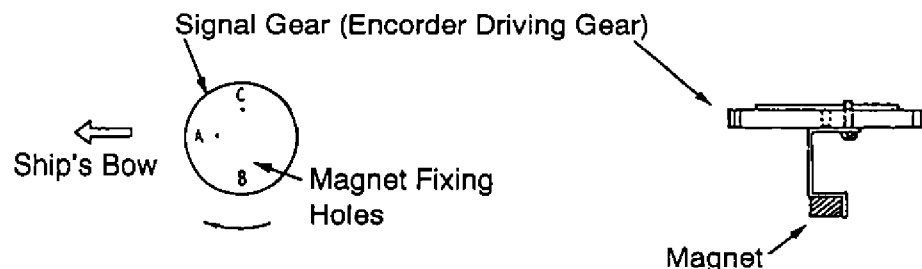
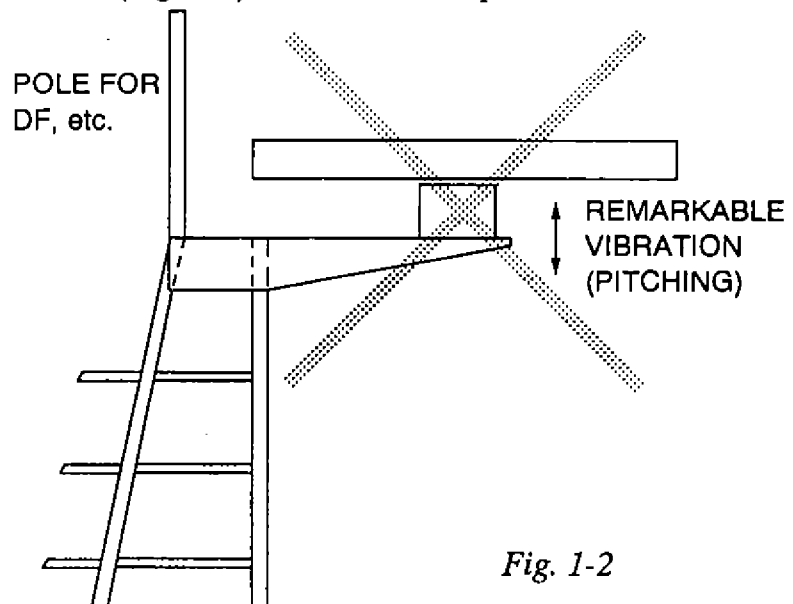
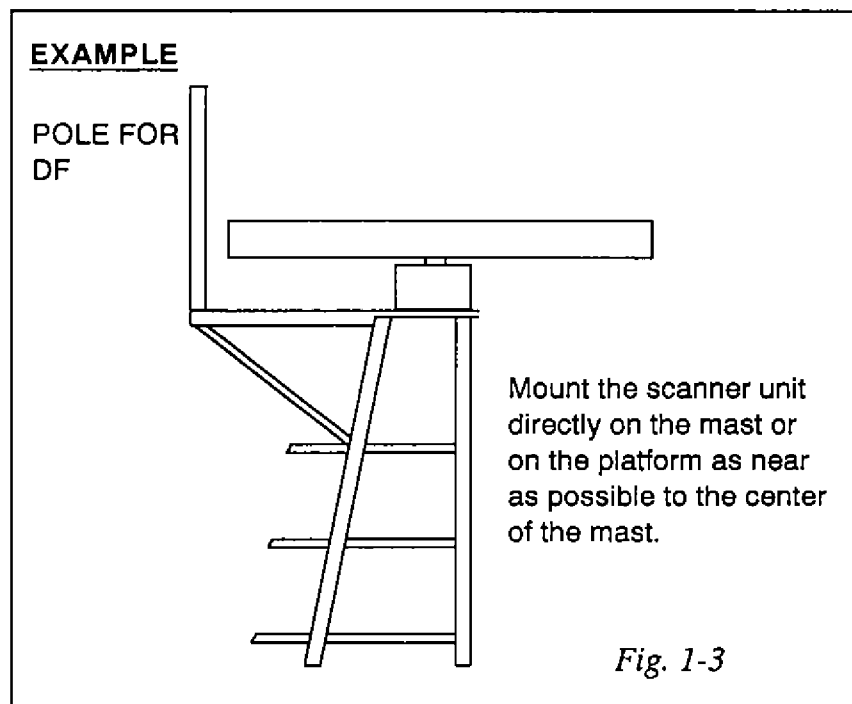

Fig. 1-1 Remounting the Synchronous Gear Magnet

Caution

- 1) The installation as shown in Fig. 1-2 may cause the radiator to be damaged, because of ship's vibration. To prevent this, mount the scanner unit on the top of the mast (Fig. 1-3) or reinforce the platform.

*Fig. 1-2*

- 2) To avoid as much as possible difficult and dangerous work atop the mast, the radiator should be assembled and fixed to the scanner unit and then raised to the mast. **HOWEVER, NEVER LIFT THE SCANNER UNIT BY THE RADIATOR.** Scanner Unit lifting guidelines are shown on page 1-5.
- 3) Observe the scanner unit installation remarks on page 1-7.
- 4) Do not paint the radiator aperture.

Assembling Radiator

Referring to Fig. 1-4 on the next page, assemble the radiator before lifting it on the mast.

1. Screw the guide pins the radiator. (2 pcs.)
2. Remove the protection cap from the choke guide.
3. Apply grease to the O-rings and fit them in the grooves of the choke guide.
4. Place the radiator on the radiator bracket. (Radiator direction is shown by the label on the bracket. If reversely oriented, the radiator can not be fitted to the bracket.)
5. Loosely fix the radiator to the radiator bracket with hexagon bolts (M10 × 25), spring washers and flat washers.
6. Remove the guide pins and tighten hexagon bolts.

For perfect watertightness, O-ring must be fitted in the grooves of the choke guide as shown below.

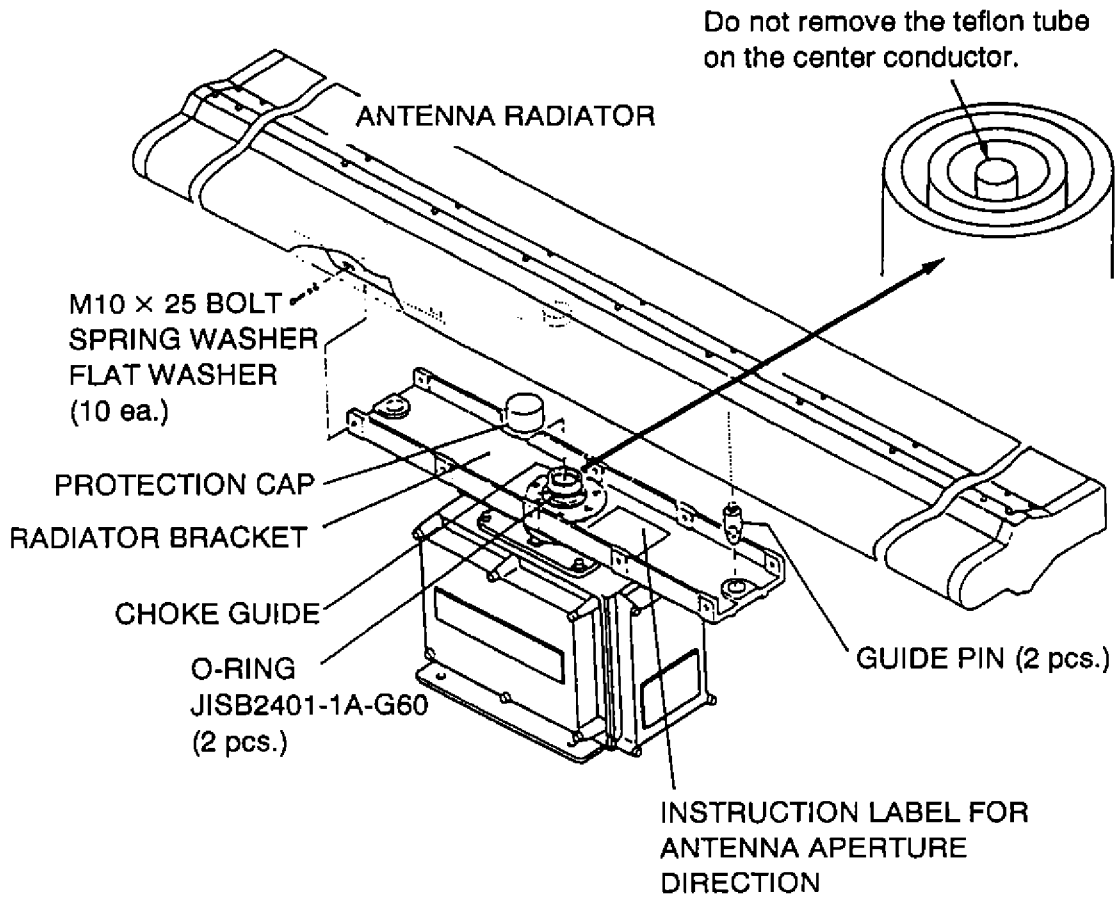

Fig. 1-4

WARNING

Do not forget remove the guide pins. Serious bodily injury may result should they loosen and fall to the deck.

SCANNER UNIT LIFTING METHOD

1. Fix the antenna radiator to the scanner base.
2. Attach the lifting fixtures and collars as shown in Fig. 1-5.
3. Position the radiator as shown in Fig. 1-6 and arrange the ropes A and B. The length of ropes A and B should be the same and more than 1m.

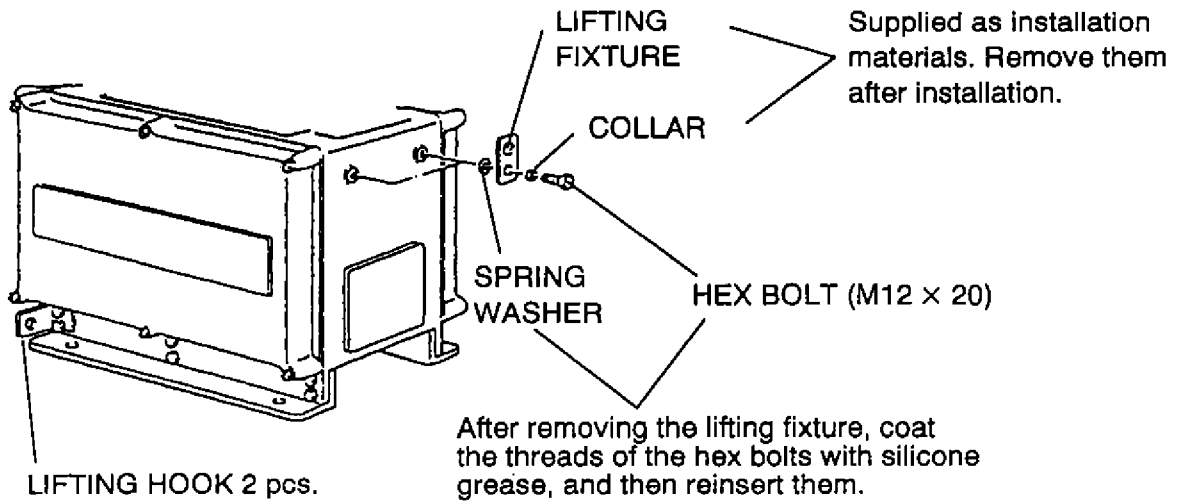

Fig. 1-5

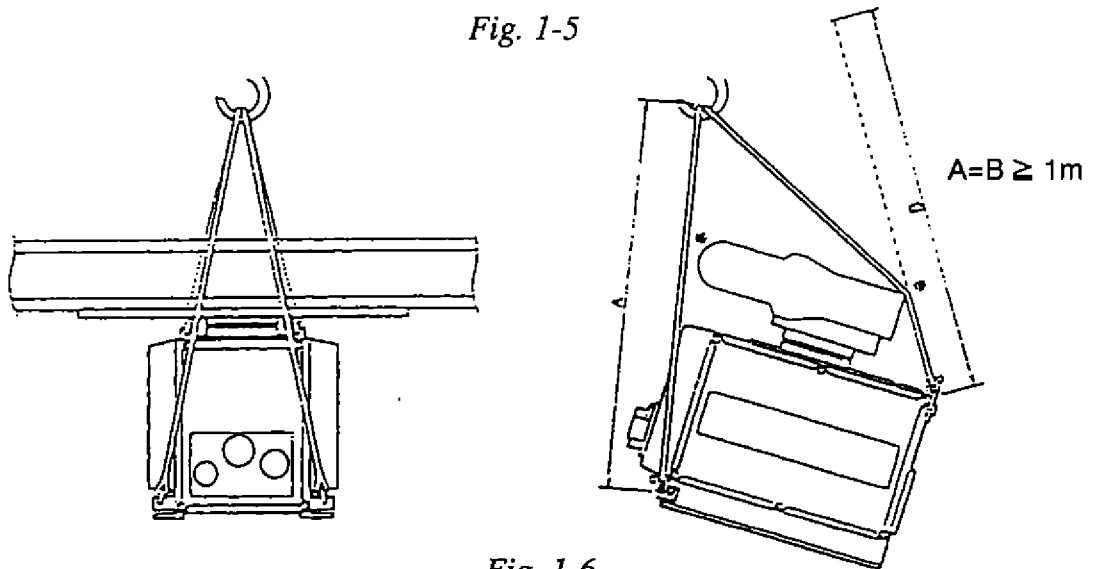

Fig. 1-6

Protect the radiator with cardboard or cloth at the places marked by ※.

Mounting procedure

The installation method for the antenna unit is illustrated on the next page.

1. Drill eight bolt holes of 15 mm diameter in the radar mast platform or the deck. For antenna unit dimensions, see the antenna unit outline drawing on the page D-6.
 - The diameter of pole for fixing the antenna base must be over 250 mm. (thickness: over 6 mm)
 - The thickness of the antenna base must be over 15 mm.
 - The reinforcement rib must be installed diagonally as shown below.

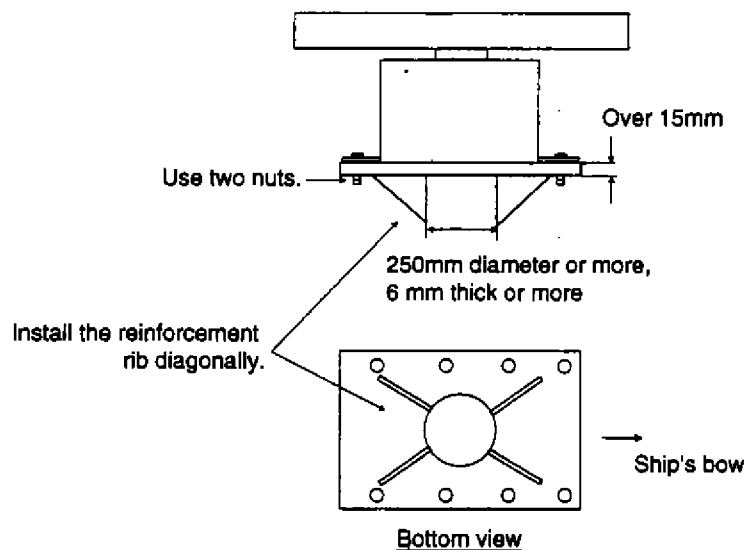

2. Place the corrosion-proof rubber mat on the chosen mounting location.
3. Following the instructions on page 1-6, lift the antenna unit with radiator and place it on the rubber mat with the cable gland facing the ship's stern (or port, starboard). The lifting fixtures should be removed after installation.
4. Fix the antenna unit to the mounting place with M12 x 70 hexagon bolts, nuts and seal washers.
 - Use two nuts per bolt for strength.
5. Arrange a ground terminal near the antenna base. Use supplied hex bolt (M6 x 25), nut and washer. Fix the supplied ground wire (RW-4747) to the ground terminal.
6. Connect the other end of the ground wire to the ground terminal on the antenna unit.
7. Apply the supplied adhesive (Non-acid type silicone sealant) to the ground terminal and the fixing bolts.

INSTALLING THE SCANNER UNIT

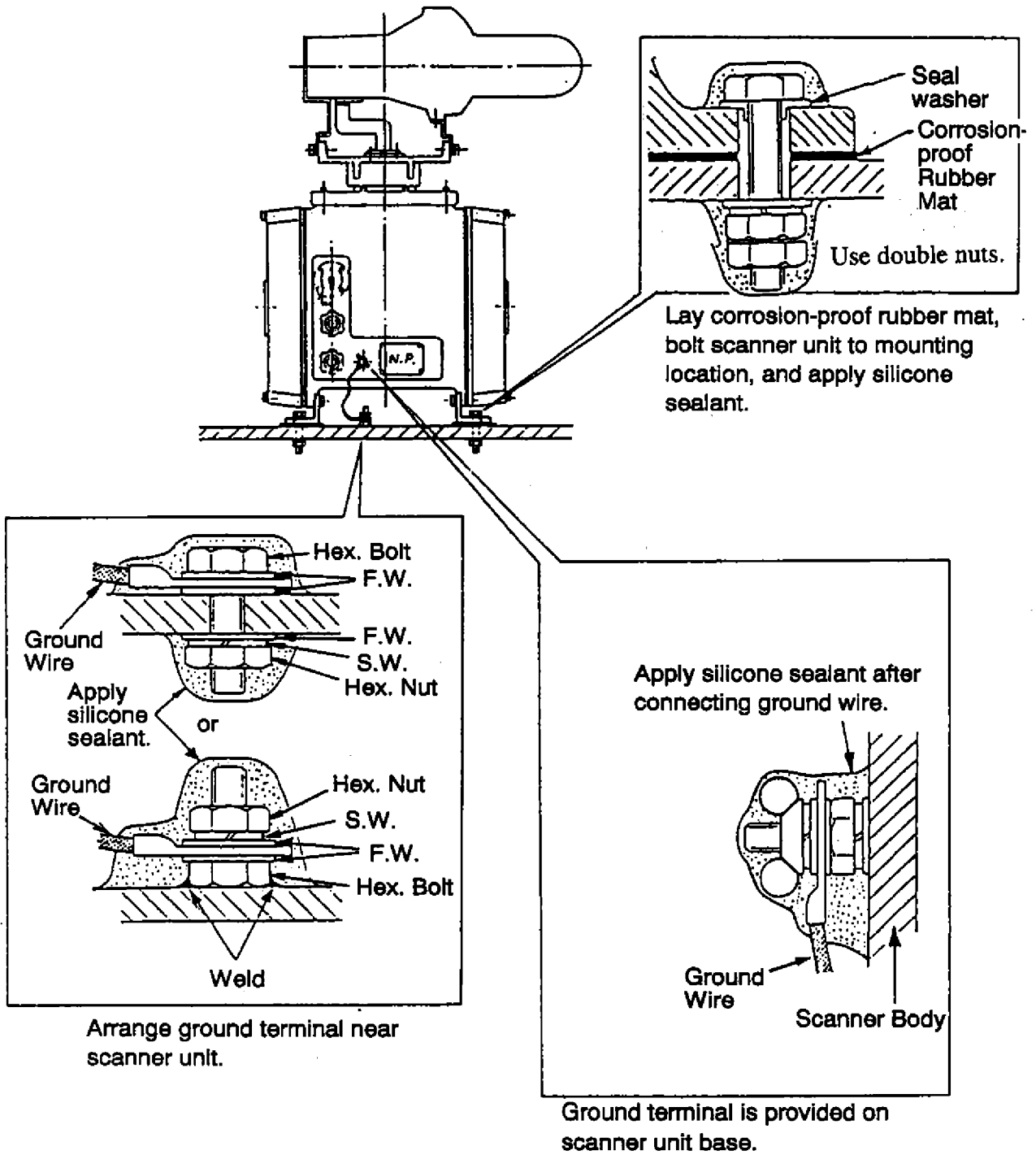

Fig.1-7

DISPLAY UNIT

Siting considerations

Locate the display unit in a place where it can be viewed and operated conveniently. Other points to consider when selecting a mounting location are as follows.

- The location should be free of water spray.
- The daylight bright type radar display provides excellent visibility even in direct sunlight. However, locate the unit out of direct sunlight and away from heat sources because of heat that can build up inside the cabinet.
- The signal cable between the scanner unit and the display unit comes supplied in length of 15, 20, 30 or 60 meters (100 meters maximum length). Keep this in mind when selecting the location.
- Leave sufficient space around the unit for maintenance and servicing. See the display unit outline drawing for recommended space.
- The orientation of the display unit should be so the operator views the screen while facing the bow. This makes determination of position much easier.

Mounting

Tabletop

- 1) Unfasten the two M10 bolts at the front of the display unit to dismount the mounting base from the display unit.
- 2) For fixing the unit by nuts, bolts and washers, mark mounting holes of 12 mm diameter in the tabletop. (Refer to the display unit outline drawing for mounting dimensions.)
- 3) Secure the mounting base to the tabletop by using 9 mm diameter coach screws, or M10 nuts, bolts and flat washers.
- 4) Place the display unit on the top of the mounting base and fasten it with the two bolts removed at step.

Console

- 1) Referring to the display unit outline drawing, mark six mounting holes of 15 mm diameter and one cable entry hole.
- 2) Open the lid at the bottom front of the unit. Fix the unit to the deck with M12 nuts, bolts and washers, or 12 mm diameter coach screws.

POWER SUPPLY UNIT

The power supply unit can be installed almost anywhere provided the location is dry, well-ventilated, the compass safe distances are observed and sufficient maintenance space is provided.

The unit may be installed inside the display unit console type.

DISPLAY UNIT

The following cables run between the display unit and the other units of the radar system.

signal cable :RW-6895 (to scanner)

power cables :TPYCY-3.5 (to power supply unit) and
:DPYCY-3.5 (to Ship's mains)

Power Cable DPYCY-3.5 (or TPYCY-3.5)

Fabricate the cable as shown below.

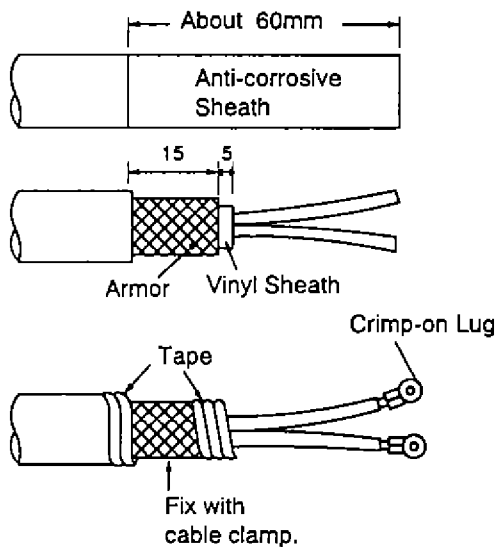

a) Remove the anti-corrosive sheath by 60mm.

b) Expose 15mm of the armor.

c) Expose 5mm of the inner sheath.

d) Cut off the sheath of each core by 10mm. Fit crimp-on lugs to each conductor.

e) Wrap the anti-corrosive sheath, armor and inner vinyl sheath with tape.

*Fig. 2-1 Fabricating Cable
DPYCY -3.5*

Fabricating display unit end of signal cable (tabletop-type)

Unwrap taping as shown below to expose the portion of the braided shield which will lie inside the cable clamp.

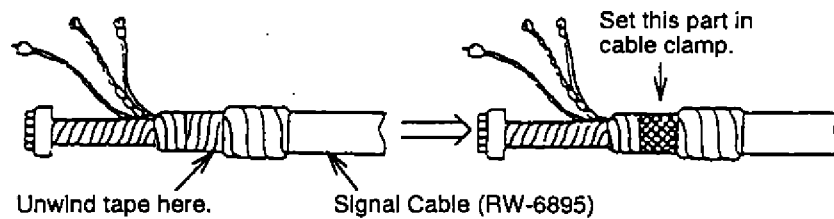

Fig. 2-2 Signal cable

(console-type)

Since the cable clamp is the underside of the console, the clamping points of the power cable, signal cable and the cables of optional equipment are different from those of the tabletop-type.

Power cable

- 1) Strip off about 3 cm of the vinyl sheath 130 cm from the end of the cable to expose braided shield.
- 2) Fabricate the end of the cable as shown in Figure 2-13.

Signal, slave display and navigational equipment cables

- 1) Strip off about 3 cm of the vinyl sheath 150 cm from the end of the cable to expose braided shield.
- 2) Tape the shield leaving about 2 cm of it exposed.

Optional gyro, speed log and ROT rudder cables

- 1) Completely remove the sheath by 150 cm from the end of each cable in order to pass the cables.

After wiring, bind the cables by cable tie.

Connections

Connect cables referring to the interconnection diagram.

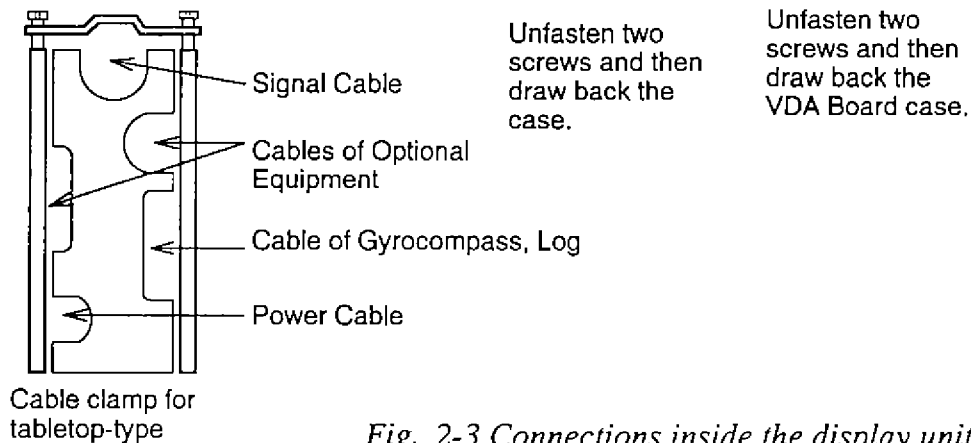
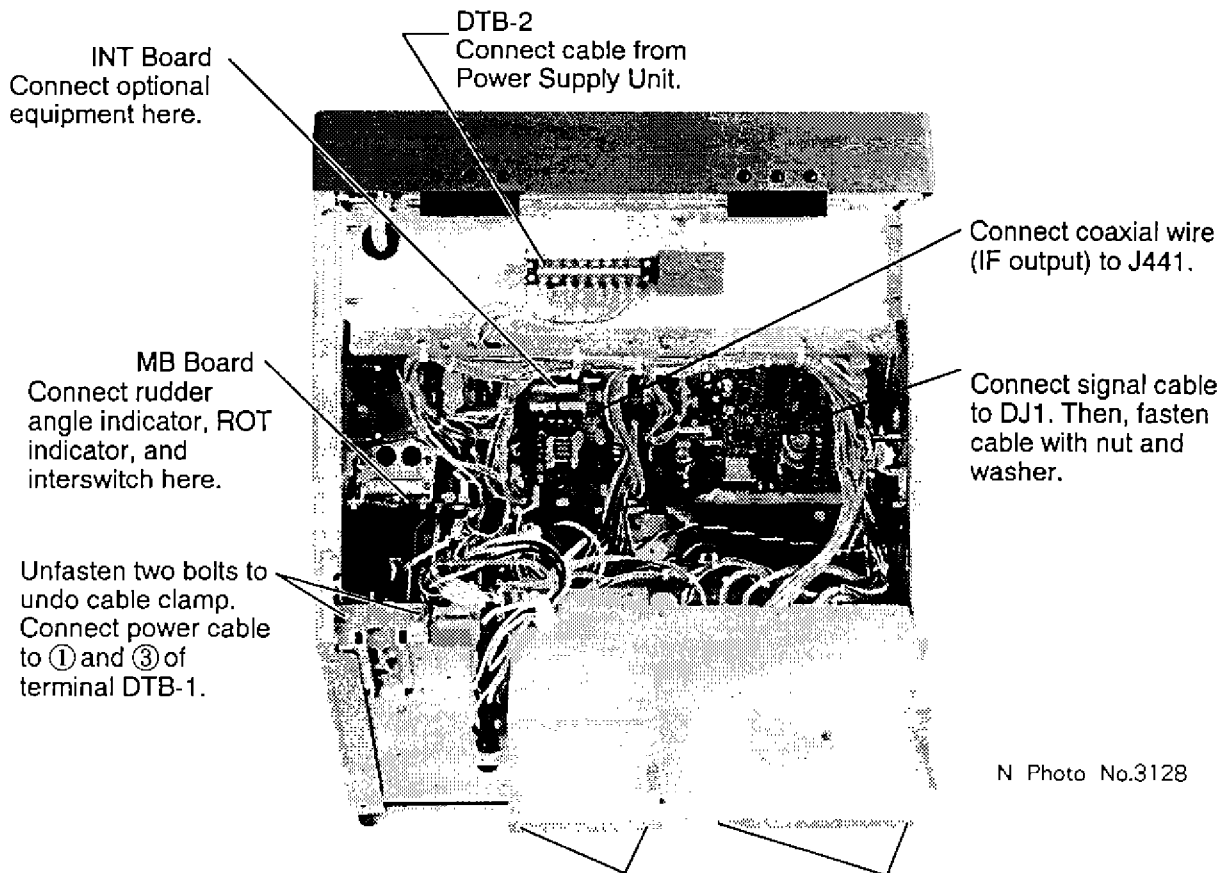
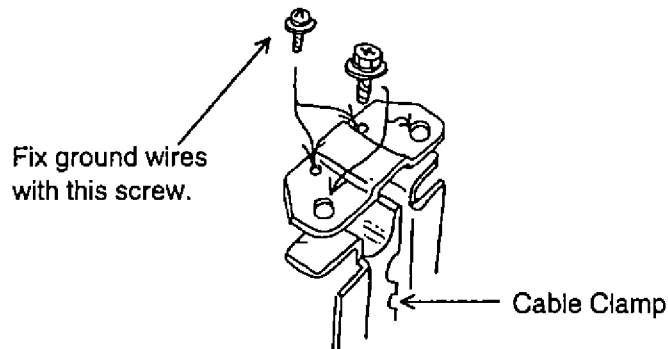

Fig. 2-3 Connections inside the display unit

Notes

- The cable clamp of the console-type display unit is on the underside of the console.
- When the control unit is separated from the display unit, connect cable between control unit J403 on the MB Board.

- When finished, cover unused cable entry gland with aluminum tape.
- Fasten the shield of the signal cable and the power cable together by a fixing screw on the terminal board DTB-1.
- Ground wires of all cables should be connected to the cable clamp as shown below.



Connection of RSD (Output data)

Radar System Data (RSD) in NMEA0183 format is output from J455 (INS) on the INT board. The ground (GND) wire of the interconnection cable is connected to #1, #3 or #5 of J442/443.

SCANNER UNIT

Two cables should be connected to the scanner unit.

Cables

Signal Cable RW-6895

1. Cut the cable to a suitable length, extending the length actually required by 600mm. Strip off about 600mm of the anti-corrosive vinyl sheath, and 590mm of the armor and the inner vinyl sheath being careful not to nick the braided shield.

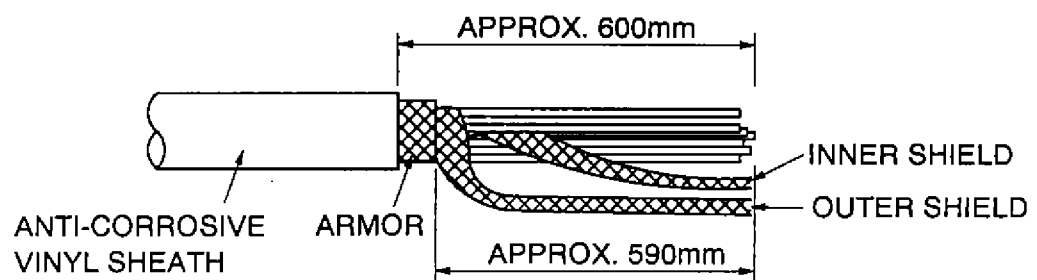

Fig. 2-4 Fabricating the Signal Cable RW-6895

2. Untwine the outer braided shield with a screwdriver, etc. to expose the cores.
3. Similar to step 2, expose the cores under the inner shield. Appropriately mark the cores for future identification.
4. Slide the clamping gland, washers and rubber packing onto the cable.

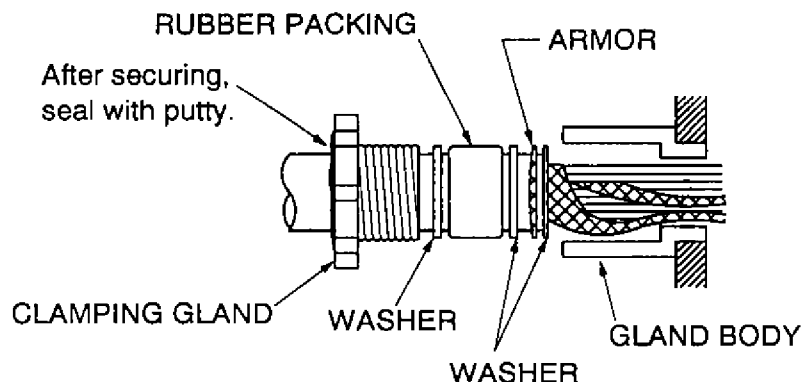

Fig. 2-5 Fabricating the Signal Cable RW-6895

5. Determine the length of each core considering its location on RTB801 (see the interconnection diagram and Fig. 2-9 on page 2-9). Trim conductors as necessary.
6. Ground the armor through the two washers as shown in Fig. 2-5. Trim the shields considering their location on the earth terminal inside the scanner unit, fit crimp-on lugs (yellow, FV2-4 $\phi 4$) to each shield, then connect to the ground terminal in the scanner unit.
7. Remove the outer sheath of the coaxial cable (2C-2V) by 75mm. Remove the shield of each core by 6mm; fold back each conductor as illustrated below. Fit crimp-on lugs to each conductor and shield.

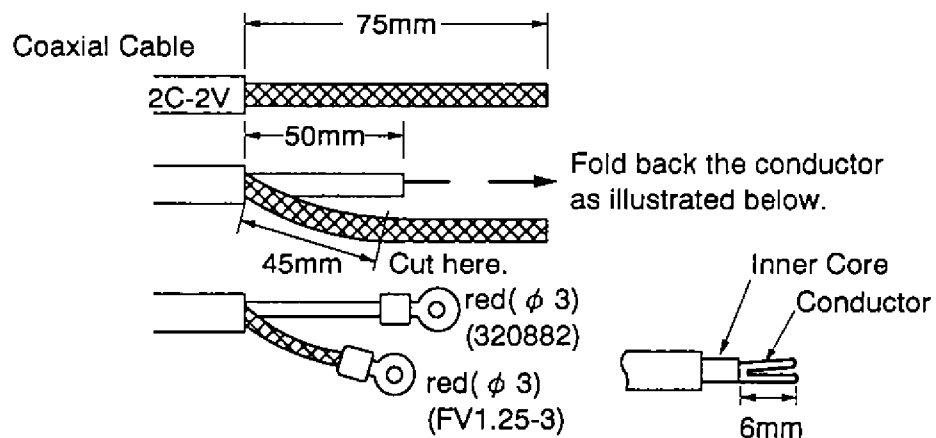

Fig. 2-6 Processing the Cores of the Coaxial Cables

8. Slip the cable gland over cable and tighten the cable gland nut. Seal the cable gland nut with putty to preserve watertight integrity.
9. Connect the outer and inner shields to the ground terminal inside the scanner. Refer to the interconnection diagram.
10. Connect the conductors to terminal RTB801 according to the interconnection diagram.

Antenna Cable MPYCY-16

1. Loosen the clamping gland of the upper cable gland, and remove the rubber packing and flat washers from the scanner unit.
2. Referring to the drawing below, cut the cable to a suitable length. Remove the vinyl sheath by 600mm. Cut off the armor by 590mm.

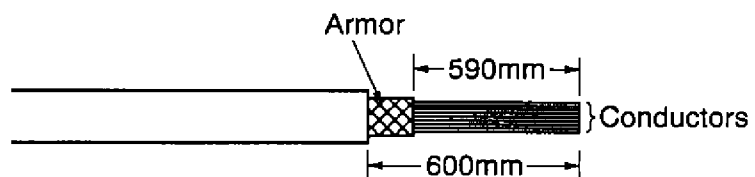

Fig. 2-7

3. Slide the clamping gland, washers and rubber packing over the cable. Fold back the armor by 5mm, then put it between washer and cable gland body as below.

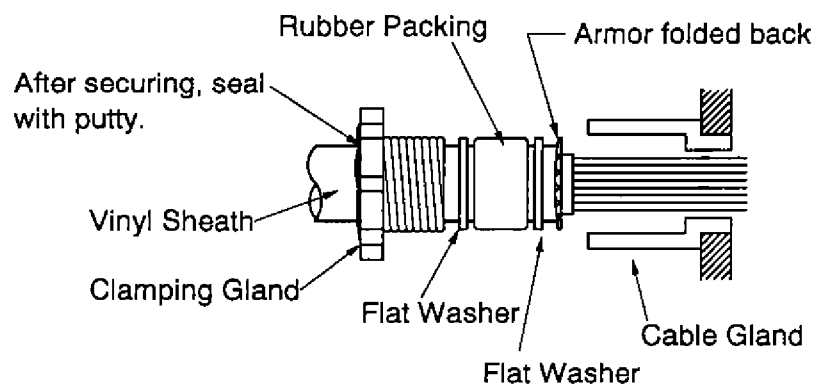

Fig. 2-8

4. Determine the length of the cores considering their location on STB1. Trim conductors as necessary. (STB1 is located behind RTB801.)
5. Ground the armor by inserting it through the washer and cable gland.
6. Remove the sheath of each core by 6mm. Fix crimp-on lugs to each conductor. Make sure each connection is secure both electrically and mechanically.

7. Secure the clamping gland to the body; then seal with putty.
8. Connect the conductors to RTB801, referring to the interconnection diagram.

After all wiring has been completed, check for loose screws, poor contact on crimp-on lugs, etc. Apply grease to scanner cover fixing screws and packing; then replace the scanner cover.

WHEN THE DE-ICER IS INSTALLED

- 1) Before beginning any work on the scanner unit, turn off the breaker for the de-icer line at the main switchboard to remove the power (100VAC, 1 ϕ) to the de-icer. (Turning off the power to the display unit has no effect.)
- 2) The neck of the scanner unit becomes VERY HOT when the de-icer is working. (The de-icer turns on when ambient temperature is below 0 °C .)

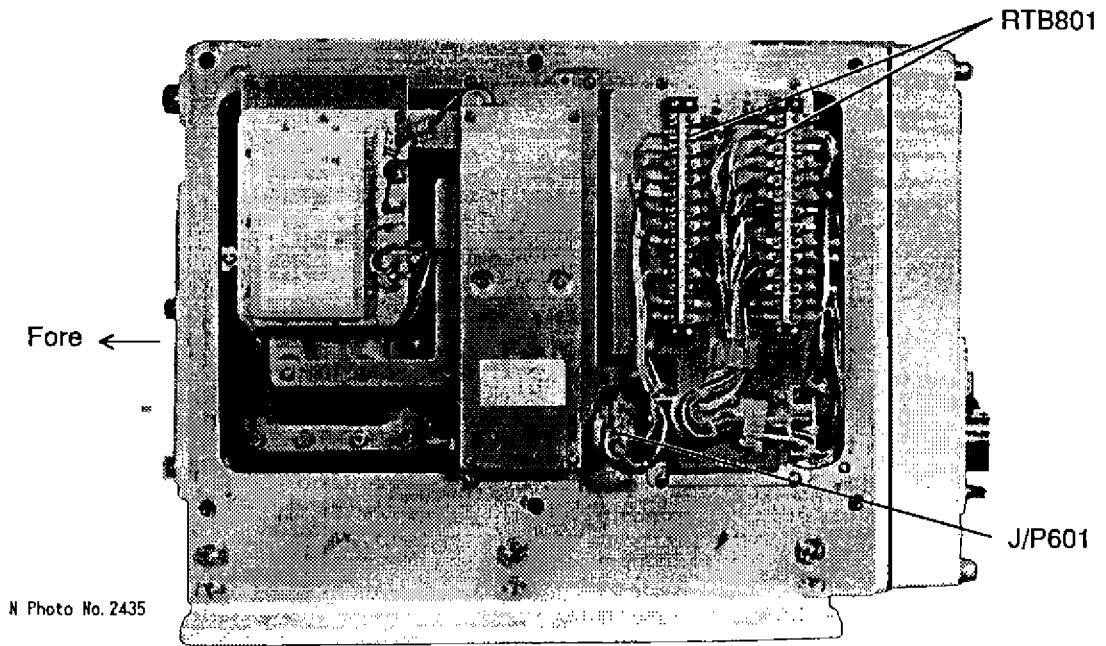

Fig. 2-9 Scanner Unit (Side View)

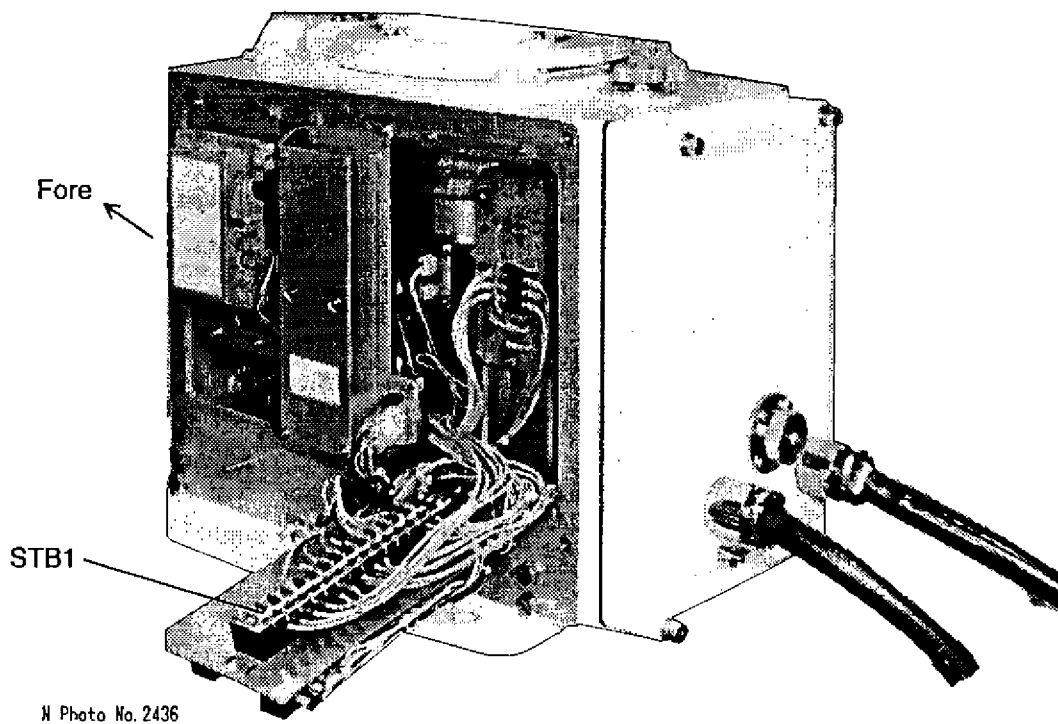

Fig. 2-10 Scanner Unit (Side View)

POWER SUPPLY UNIT

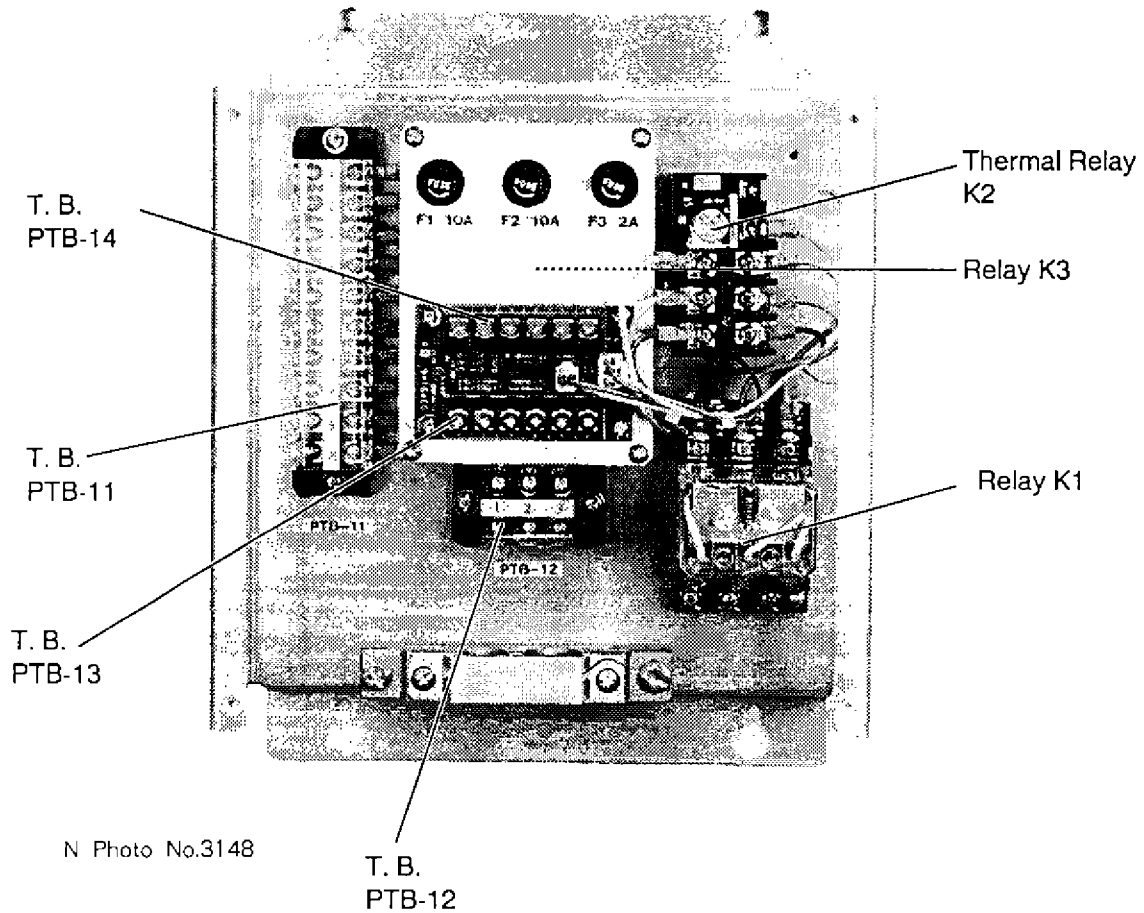

Fig. 2-11

The table below lists the thermal relays to be used in the Power Supply Unit. The type of the relay and its presetting differs according to ship's mains.

Ship's Mains	Scanner Unit	Thermal Relay (K2)	
		Type	Presetting
200/220VAC, 3 ϕ	RSB-0026/26A	T20A-Q 2.3A	2.3A
380/440VAC, 3 ϕ	RSB-0031/31A	T20A-Q 1A	1A









Refer to Fig. 2-1, for the fabrication of the TPYCY (DPYCY) cables. The maximum cable length between the cable clamp and the terminal board is about 350mm.

INITIALIZATION AND ADJUSTMENT

IMPORTANT!

Before proceeding the initialization and adjustment, radar model should be selected on the INITIAL SETTING menu.

Follow the steps below.

1. Set the DIP Switch S1, #4 to "ON".
2. Press        and the INITIAL SETTING 4 menu will appear.
3. Pressing  changes the radar model. "OTHER X-BND" includes FR-2120W/2150W/2150, while "OTHER S-BND" includes FR-2130S/2130SW/2160SW.

The "Adjustment Check List", provided at the end of this chapter will help you not miss any necessary setting and adjustment.

Selection of Vessel Class

Overview

The radar has two sets of menu systems: one for merchant vessels and one for fishing vessels. Select one according to class of vessel.

Request for removal of pages in operator's manual

The operator's manual contains pages marked for use by merchant vessels or fishing vessels. Those are pages 9, 10 and 14. Please remove inapplicable pages.

How to select

The #2 segment of DIP Switch S1 on the SPU Board (SPU-9111) sets class of vessel. Set it accordingly as shown in the table which follows.

S1#2	Specification
ON	Fishing Vessel
OFF	Merchant Vessel

Differences in specifications

The items appearing on the RADAR and NAV menus differ by vessel specification. Table 3-1 tabulates those differences.

Table 3-1 Differences in menus for merchant and fishing vessels

Menu	Fishing Vessel Specification	Merchant Vessel Specification
RADAR menu, FUNCTION KEY menus	The items "RIVER" and "BIRD" appear.	No "RIVER" nor "BIRD".
RADAR menu, SYSTEM SETTING 1 menu	The item "LONG LINE" appears with connection of RP-23 (option).	No "LONG LINE".
NAV menu, NAV INFORMATION 3 menu	Depth unit available in meters, feet or fathoms.	Meters only

Setting Function Keys

Overview

The radar has three function keys which automatically set up the radar according to the conditions ascribed to them. Confer with ship owner and radar operator to determine suitable program for each key. Attach appropriate key label (supplied with the accessories package) to each key to denote their function.

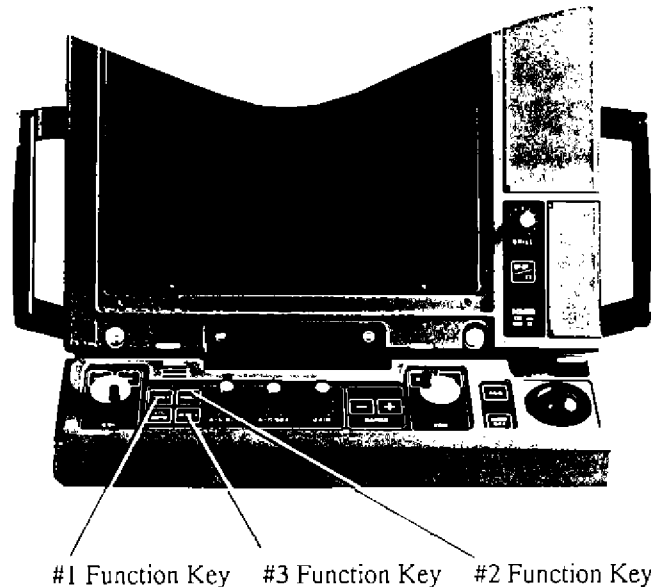

N Photo No.3124

Figure 3-1 Display unit, front view

Procedure

Refer to pages 9 through 11 in the operator's manual.

- Assign task to each function key: picture setup, specific operation or watch alarm (function key #3 only).
- Each picture setup condition is programmed with optimal settings for interference rejection, echo stretch, echo averaging, automatic clutter removal, pulsewidth, and noise rejection. Therefore, adjustment of the default setting is not necessary. Any adjustment may adversely affect the target detection ability of the radar. Please explain this to the user.

Restoring default function key settings

Open INITIAL SETTING 3 menu and select "0. FACTORY DEFAULT".

Adjustment of Video Amplifier Level

Overview

When the signal cable is very long, the video amplifier input level decreases, shrinking target echoes. To prevent this, confirm (and adjust if necessary) video amplifier input level.

Procedure

- 1) Transmit the radar on the 12 mile range.
- 2) Measure video amplifier input level on the VIDEO AMP Board (VDA-9114) in the display unit as directed in the table which follows.

Check Point	Rating	Measuring Conditions	Adjustment Pot.
TP3 (take trigger at TP11)	4.2 V _{pp} (strong signal)	Turn off A/C SEA, A/C RAIN, and INTERFERENCE REJECTION.	VR1 (LEVEL)

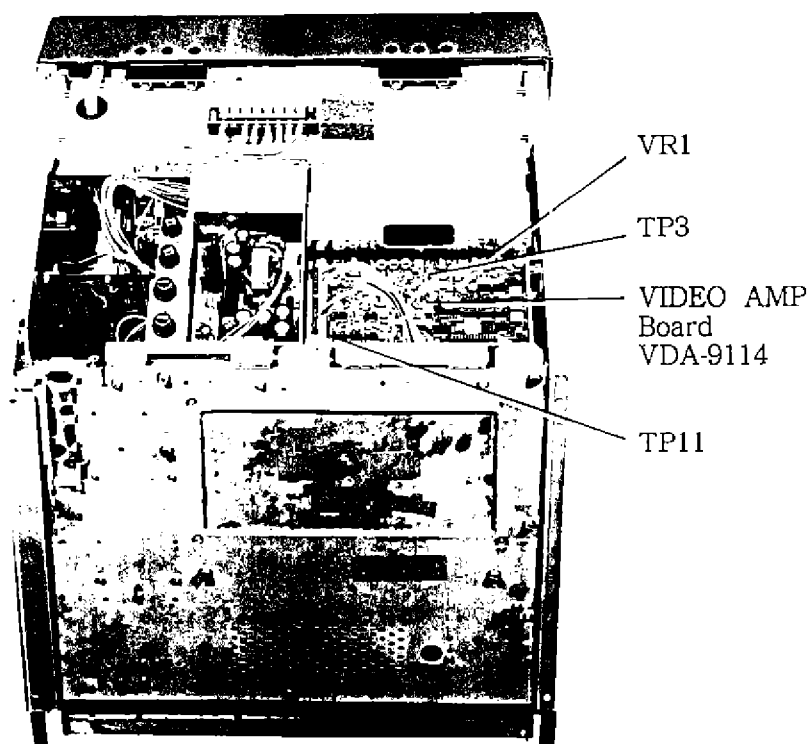

Figure 3-2 Display unit, top view, cover removed

Suppression of Main Bang

Overview

If main bang appears at the screen center, suppress it as follows.

Procedure

- 1) Transmit the radar on a long range for 10 minutes. Adjust the gain control so that there is a slight amount of noise visible on the screen.
- 2) Set the range to 0.25 nm and adjust the **A/C SEA** control for best picture definition.
- 3) Turn VR301 (MBS Level) and VR302 (MBS Timing) fully CW. Potentionmeters VR301 and VR302 are located inside the top right-hand panel of the display unit.
- 4) Turn VR302 ccw little by little until the main bang ring disappears.
- 5) Turn VR301 ccw little by little until the main bang ring becomes faintly visible on the screen.
- 6) Turn VR301 and VR302 ccw little by little until the main bang ring disappears.

Note: *Too high a setting of MBS will cause the target echoes in close ranges to disappear.*

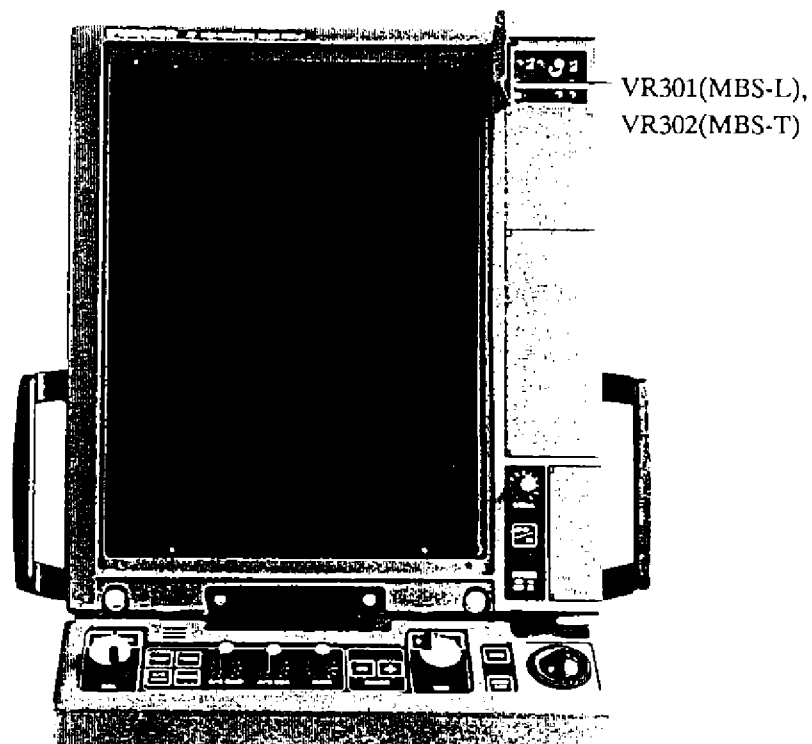

N Photo No.3124

Figure 3-3 Display unit, front view

Adjustment of Tuning

Overview

The radar receiver can be tuned both automatically and manually. Confirm that the receiver is properly tuned in both conditions.

Procedure

Adjust tuning with the TUNE switch and TUNE control inside the top right-hand panel on the display unit.

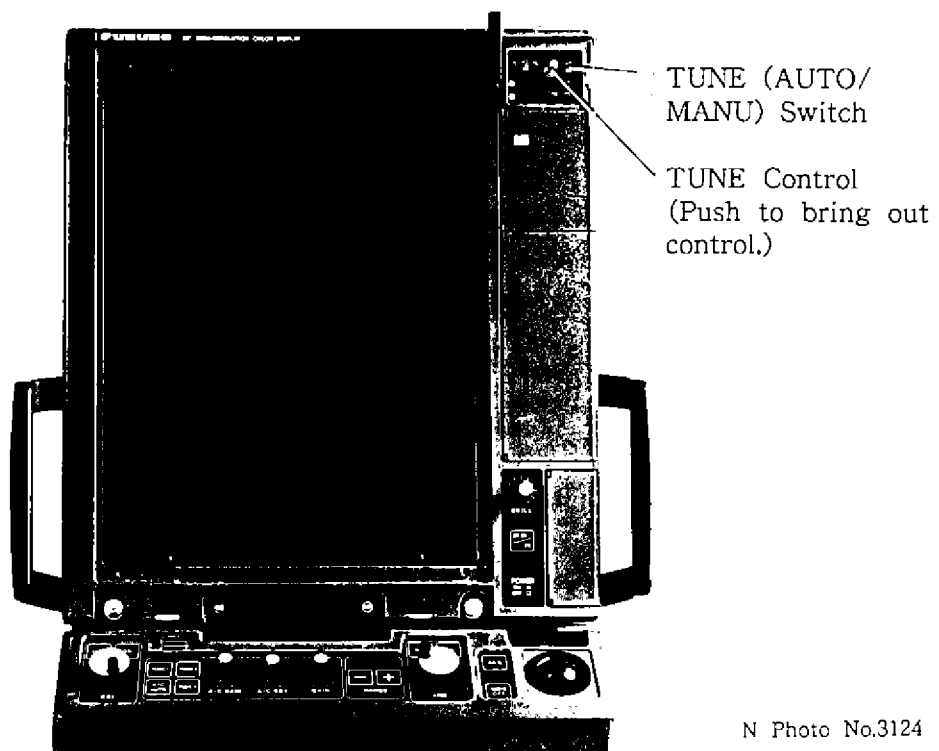

N Photo No.3124

Figure 3-4 Display unit, front view

- 1) Set the TUNE switch to MANU. Transmit the radar on the 48 mile range. Adjust sensitivity and picture brilliance, and set **A/C SEA** and **A/C RAIN** controls fully counterclockwise (off).
- 2) While observing the picture, adjust the TUNE control slowly to find best tuning point. (Turning the control quickly two or more turns counterclockwise or clockwise yields lowest or highest tuning voltage, respectively.)
- 3) Set the TUNE switch to AUTO. Wait until the radar is tuned (about 10 seconds or about four scanner rotations).
- 4) Confirm that the radar found best tuning point. Peak tuning is obtained when about 80% of the tuning display lights.

Initialization

Overview

Initialization sets up the radar by the following conditions

- (1) required settings
- (2) user requests (if applicable)
- (3) settings required by a service technician, and
- (4) factory settings only.

Table 3-2 shows where you set the above-mentioned conditions.

Table 3-2 Initialization items and where to set them

Menu Condition	INITIAL SETTING					SHIP INFO.
	1	2	3	4	5	
(1)	2 to 6			2		2 to 4
(2)		2 to 4	2 to 4	4, 5	6, 9	
(3)	8 to 9	5 to 9	5			5 to 7
(4)			6, 7			

How to display the menus for initialization

The menus for initialization of the radar (INITIAL SETTING and SHIP INFORMATION) are not accessible by the user, to prevent adjustment of settings. To access the menus, turn on the #4 segment of DIP Switch S1 on the SPU Board in the display unit. Then you can access them by pressing the **RADAR MENU** key. See the next page for initial setting menu tree.

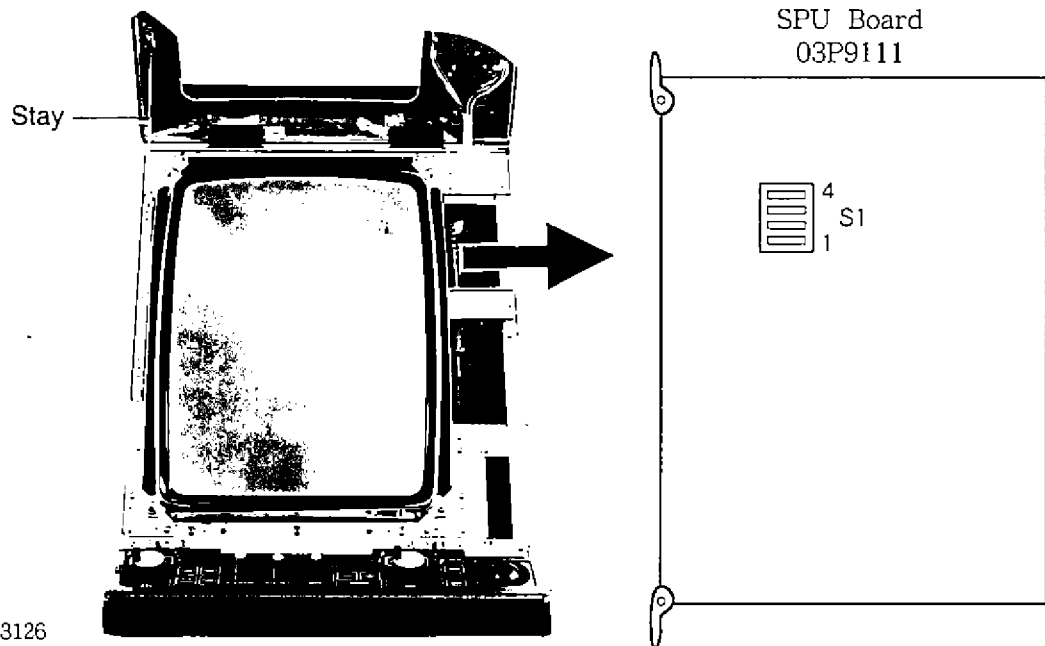
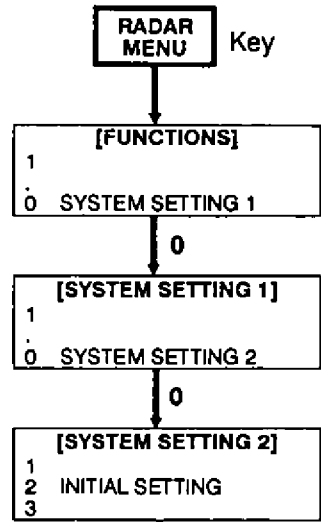

Photo No.3126

Figure 3-5 Display unit, front view, cover opened, showing location of SPU Board

Initial settings menu tree



NOTE: Default settings appear in boldface.

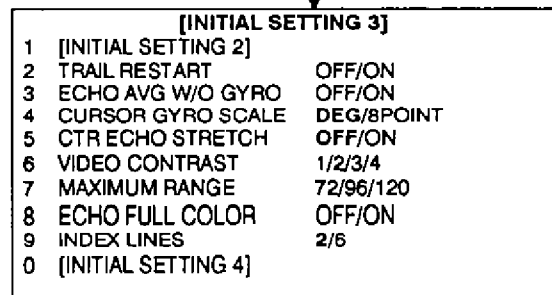
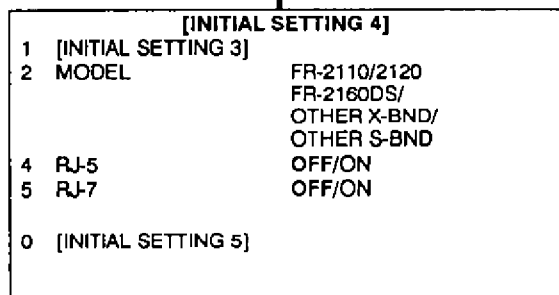
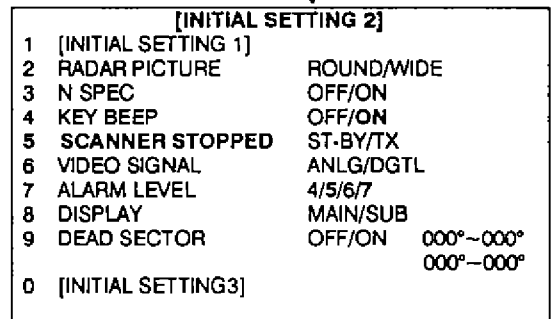
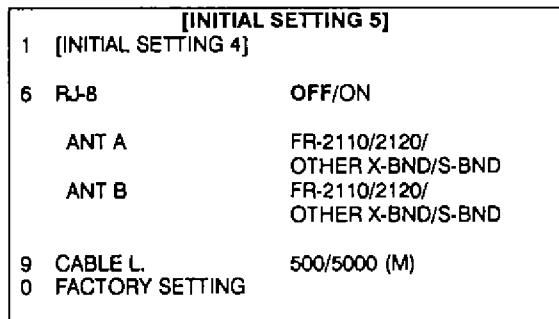
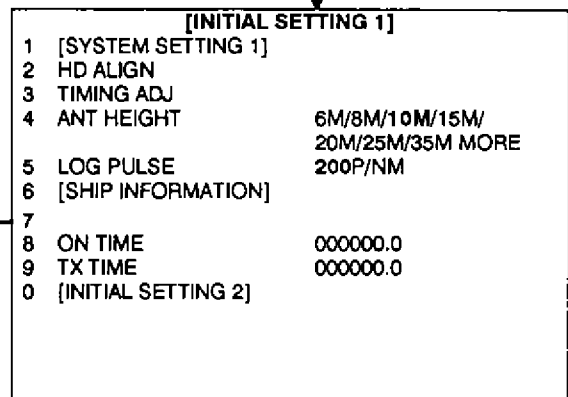
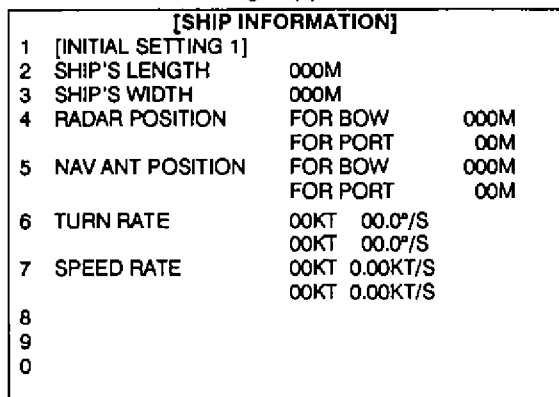



Setting procedure

- 1) Press numeral key to select item.
- 2) Press **same** numeral key pressed in step 1 to select option. Current selection appears in reverse video.
- 3) Set other items by repeating steps 1 and 2.
- 4) Press the **ENTER** key to register options.
- 5) Press the **RADAR MENU** key to close the menu.

**Initial settings
menus description**

Table 3-3 describes the initial settings menus. Menu items in boldface must be set at installation.

Table 3-3 Initial settings menu description

Item	Function
INITIAL SETTING 1 menu	
HD ALIGN	Compensate for scanner unit installation error in ship's bow direction. See page 3-14.
TIMING ADJ	Sweep timing varies with the length of the signal cable between the scanner unit and display unit. See page 3-13.
ANT HEIGHT	Set height from sea surface to scanner radiator.
LOG PULSE	Set speed log's pulse rate.
ON TIME	Display total hours the radar has been turned on and transmitted. Service technician can change display when replacing magnetron, etc.
TX TIME	
SHIP INFORMATION menu	
SHIP'S LENGTH	Set ship's physical data, for use with anchor watch alarm, etc.
SHIP'S WIDTH	
RADAR POSITION	
NAV ANT POSITION	
TURN RATE	
SPEED RATE	
INITIAL SETTING 2 menu	
RADAR PICTURE	Select round or wide type display. round:  wide: 

(Continued)

Item	Function
N SPEC	Select ON for IMO merchant vessels; OFF for all other vessels.
KEY BEEP	Turn key response beep on or off. Turn OFF for IMO merchant vessels.
SCANNER STOPPED	Set to ST-BY in normal use. Select TX to confirm magnetron heater voltage of 25 kW magnetron, etc.
VIDEO SIGNAL	Set to ANLG in normal use. Select DGTL to adjust QV (quantized video) when the radar is equipped with Auto Plotter ARP-23 (option).
ALARM LEVEL	Set echo strength level which triggers guard alarm. "7" is strongest echo and "4", medium strength echo.
DISPLAY	Select radar display function; main or sub (slave).
DEAD SECTOR	<p>This menu can set two areas where no radar pulse is to be transmitted. Areas in which a strong reflected pulse could damage the receiver or the possibility of health hazard exists should be entered.</p> <p>If there is a large mast at the rear of the scanner, for example, this may produce a wide dead sector on the display. Any target echoes within the area may not show up on the display. Allowing the radar pulse to pass through the body may cause health problems. Therefore, an area where passengers or crew might approach too close to the radiator should be entered.</p> <p>To prevent transmission in area(s), select ON and enter relative bearing range of the area(s) here.</p>
INITIAL SETTING 3 menu	
TRAIL RESTART	Select whether to restart or discontinue echo trailing when changing the range. Set to ON to restart trailing, or OFF to discontinue.

(Continued)

Item	Function
ECHO AVG W/O GYRO	Normally, echo averaging is turned off when there is no gyrocompass connection, because stable picture cannot be obtained. However, it can be turned on with no gyrocompass connection.
CURSOR GYRO SCALE	Scale may be shown in degrees or compass points.
CTR ECHO STRETCH	Set to "ON" to enlarge echo in the range of 0 to 100 meters.
VIDEO CONTRAST	These are set at the factory; do not change them in the field.
MAXIMUM RANGE	
ECHO FULL COLOR	Echo can be presented in multi-color.
INDEX LINES	Number of index line is selectable to 2 or 6.
INITIAL SETTING 4 menu	
MODEL	Select your radar type. This setting changes a set of pulselength, PRF and STC curve.
RJ-5	When optional RJ-5 is connected, set this menu to "ON".
RJ-7	When optional RJ-7 is connected, set this menu to "ON".
INITIAL SETTING 5 menu	
RJ-8	When optional RJ-8 is connected, set this menu to "ON".
CABLE L.	Always set to "500".
FACTORY DEFAULT	Restore all menus' default settings.

After registering settings

Turn off the #4 segment of DIP Switch S1 to close the initial settings menus.

When replacing SPU board

Initial setting data are written to the EEPROM (U47, U48) on the SPU Board. When replacing the SPU Board, exchange the EEPROM on the replacement board with the original EEPROM. Otherwise, the radar operates by default initial settings.

Adjustment of Magnetron Heater Voltage

Overview

Magnetron heater voltage is adjusted at the factory. However, confirm that it is within the prescribed rating.

Procedure

1. Call up the "INITIAL SETTING 2 menu", and set "5. SCANNER STOPPED" to "TX". This setting allows the radar to transmit with scanner stopped.
2. Set the radar to "ST-BY", 0.25 nm range, and CRT brilliance control fully ccw.
3. Turn the scanner switch off. (inside top panel)
4. Connect a multimeter set to 10 VDC range between #4 (+) and #6 (-) of pulse transformer T801. See the figure below for parts location.
5. Adjust the position of the sliding contact of R812 for a multimeter reading of 6.3 V.
6. Remove the fuse F3 (0.5 A) on the display unit.
7. Set the radar to TX/48 nm range.
8. Adjust R811 for a multimeter reading of 5.3V.

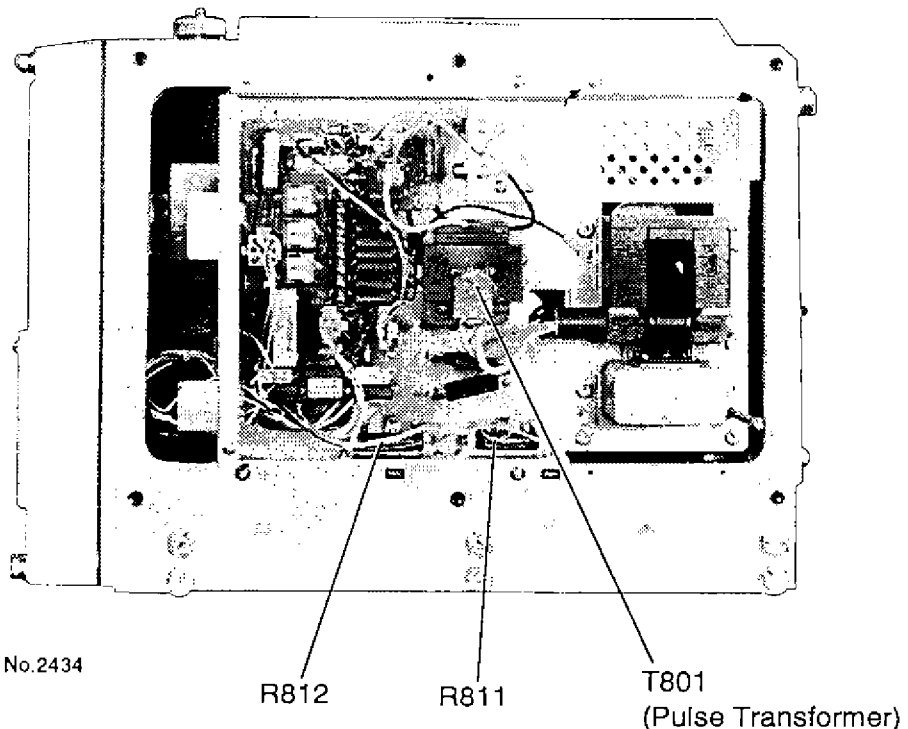

Figure 3-6 Scanner Unit, Showing Location of Pulse Transformer

Adjustment of Sweep Timing

Overview

Sweep timing differs with respect to the length of the signal cable between the scanner unit and the display unit. Adjust sweep timing at installation to prevent the following symptoms:

- The echo of a “straight” target (for example, pier), on the 0.25 mile range, will appear on the display as being pulled inward or pushed outward. See Figure 3-7.
- The range of target echoes will also be incorrectly shown.

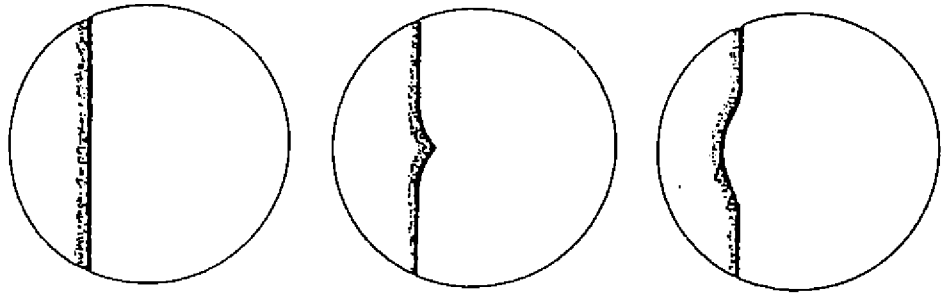

(1) Correct (2) Target pushed inward. (3) Target pulled outward.

Figure 3-7 Examples of correct and incorrect sweep timings

Procedure

- 1) Open INITIAL SETTING 1 menu and select “3. TIMING ADJ”.
- 2) Transmit on the 0.25 mile range.
- 3) Adjust radar controls to display picture properly.
- 4) Select an echo which should be displayed straightly. Adjust the VRM rotary control to straighten target echo.

■ **NOTE:** *The readout which changes with VRM rotary control operation is unrelated to this adjustment. Please disregard it.*

- 5) Press the **ENTER** key.

Alignment of Heading

Overview

Scanner unit mounting error (heading reed switch timing error) can be compensated at the display unit.

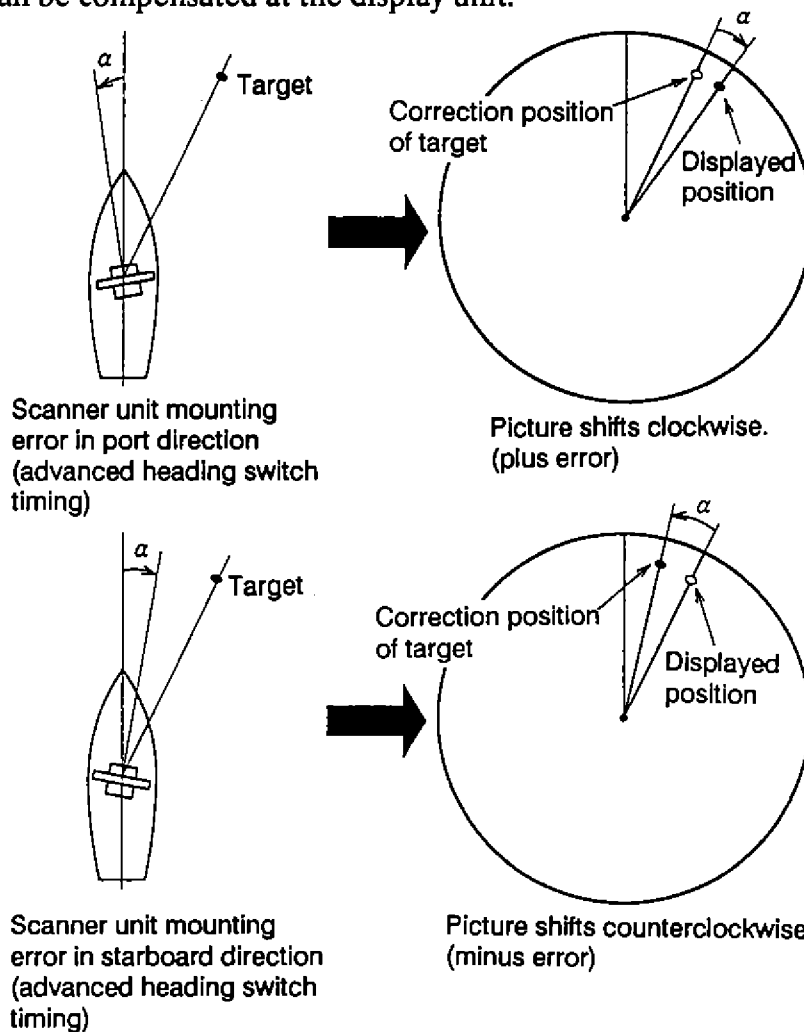

Figure 3-8 Scanner unit mounting error

Procedure

- 1) Open INITIAL SETTING 1 menu and select "2. HD ALIGN".
- 2) Operate EBL rotary control to shift target echo to correct position.
- 3) Press the **ENTER** key.

Adjustment Check List

Confirm completion by ticking boxes.

1 SELECTION OF MERCHANT/FISHING VESSEL SPECIFICATION

Turn off power.

Set #2 of DIP Switch S1 on SPU Board SPU-9111 as follows:
Merchant: OFF
Fishing: ON

OPENING INITIAL SETTINGS MENUS

Turn on #4 of DIP Switch S1.

Turn on power.

After completing all adjustments, turn off #4 of DIP Switch S1.

2 SETTING OF VIDEO STC CURVE (entering antenna height)

Open INITIAL SETTING 1 menu and select "4. ANT HEIGHT".

Enter height of antenna above waterline.

ENTER

3 CONFIRMATION OF MAGNETRON HEATER VOLTAGE

RADAR MENU (([FUNCTIONS] menu)

0

(([SYSTEM SETTING 1] menu)

0

(([SYSTEM SETTING 2] menu)

2

(([INITIAL SETTING 1] menu)

0

(([INITIAL SETTING 2] menu)

5

Select "TX".

ENTER

(To transmit with scanner rotation suspended.)

RADAR MENU ("ST-BY" display screen)

Turn off SCAN switch (in top panel).

Open cover at stern side of scanner unit.

Measure voltage between #4(+) and #6(-) of T801. It should be 6.3V. If not, adjust R812.

Remove fuse F3 (0.5A) on display unit.

Transmit on 48 mile range.

Measure voltage between #4(+) and #6(-) of T801. Confirm that the voltage is 5.3V. If not, adjust R811.

Close scanner unit cover.

Turn power switch off.

Reinsert fuse F3 (0.5A).

Turn power switch on.

Open INITIAL SETTING 2 menu and set "5. SCANNER STOPPED" to "ST-BY".

Turn on SCAN switch.

4 PRESETTING OF TUNING /TUNING DISPLAY

Set TUNE switch (in top panel) to MANU.

Transmit on 48 mile range.

Observe picture and tune by TUNE control (in top panel).

Set TUNE switch to AUTO. Wait about 10 seconds (four scanner rotations) to find tuning point.

Confirm peak tuning.

5 ADJUSTMENT OF VIDEO AMPLIFIER INPUT LEVEL

Transmit on 12 mile range.

Measure level of strong echo at TP3 on VDA Board (take trigger at TP11). It should be 4.2Vpp. If not, adjust VR1.

6 ADJUSTMENT OF SWEEP TIMING

Open INITIAL SETTING 1 menu and select "3. TIMING ADJ".

↓

Transmit on 0.25 mile range. Select an echo which should be displayed straightly (pier, etc.). Adjust VRM control to straighten echo.

↓

ENTER

7 ALIGNMENT OF HEADING

Check display for error direction;
 picture shifted clockwise...plus error
 picture shifted counterclockwise...minus error

↓

Open INITIAL SETTING 1 menu and select "2. HD ALIGN".

↓

Operate EBL rotary control to shift target echo to correct position.

↓

ENTER

8 SUPPRESSION OF MAIN BANG

Transmit on 48 mile range for 10 min. Then, adjust sensitivity to show small amount of noise on display.

↓

Change to 0.25 mile range and adjust A/C SEA to suppress sea clutter.

↓

Turn VR301 (Level) and VR302 (Timing) fully cw.

↓

Turn VR302 ccw until the main bang ring disappears.

↓

Turn VR301 ccw until the main bang ring becomes faintly visible.

↓

Turn VR301/VR302 ccw until the main bang ring disappears.

9 SETTING OF FUNCTION KEYS

Assign function (picture setup, specific operation, or watch alarm) according to user's request.

↓

Attach appropriate key label (supplied) to each function key.

10 TURN OFF #4 OF DIP SWITCH S1 ON SPU BOARD

INITIAL SETTINGS MENUS



- 1) INITIAL SETTING 1
- 2) INITIAL SETTING 2
- 3) INITIAL SETTING 3
- 4) INITIAL SETTING 4
- 5) INITIAL SETTING 5

SYSTEM CONFIGURATION

COMPLETE SET

No.	Name	Type	Wt. (kg)	Qty	Remarks
1	Scanner Unit See notes 1 & 2.	SN5AF-RSB-0026-N-2S	120	1	Scanner motor: AC200/220V, 3 ϕ , 50/60Hz, 400W Radiator Length: SN5AF (270 cm), SN7AF (380 cm)
		SN5AF-RSB-0026A-N-2S			
		SN5AF-RSB-0026-I-2S			
		SN5AF-RSB-0026A-I-2S			
		SN7AF-RSB-0026-N-2S	130		
		SN7AF-RSB-0026A-N-2S			
		SN7AF-RSB-0026-I-2S			
		SN7AF-RSB-0026A-I-2S			
		SN5AF-RSB-0031-N-2S	120		
		SN5AF-RSB-0031A-N-2S			
		SN5AF-RSB-0031-I-2S			
		SN5AF-RSB-0031A-I-2S			
		SN7AF-RSB-0031-N-2S	130		
		SN7AF-RSB-0031A-N-2S			
SN7AF-RSB-0031-I-2S					
SN7AF-RSB-0031A-I-2S					
2	Display Unit	RDP-106	100	1	Console type
			50		Tabletop type
3	Power Supply Unit	PSU-004	2.3	1	
4	Accessories	FP03-05420		1 set	Tabletop Type
		FP03-05430			Console Type
5	Installation Materials	CP03-13934		1 set	For display unit
		CP03-13935			For scanner unit
		CP03-13907			For power supply unit
6	Signal Cable	S03-17-15 (28, 2P) 15M		1	
		S03-17-20 (28, 2P) 20M			
		S03-17-30 (28, 2P) 30M			
		S03-17-60 (28, 2P) 60M			
7	Spare Parts	SP03-09930		1 set	For display unit
		SP03-10320			For power supply unit

Note: 1) N: No de-icer, I: De-icer fitted
 2) RSB-0026A/31A: No front-end (RF) amplifier
 RSB-0026/31: Front-end (RF) amplifier incorporated

OPTION

No.	Name	Type	Code No.	Remarks
1	Gyro Converter (1 set)	GC-8	008-446-520	Built in display unit. See page B-1.
2	Video Plotter (1 set)	RP-23	008-446-550	Built in display unit, under development
3	Auto Plotter (1 set)	ARP-23	008-446-530	Built in display unit, under development
4	Non-glare Filter	OP03-111	008-446-640	
5	Display Unit Grip (1 set)	OP03-70	008-423-420	
6	External Buzzer	OP03-21	000-030-097	1 m, with connector
7	Power Cable	CVV-S 8 × 2C	000-560-634	15 m, DC spec.
8	Rectifier (1 set)	RU-3424	000-030-441	DC spec. (for AC mains)
9	parate Control Unit Kit	OP03-109	008-446-600	10 m interconnection cable
10	Range Unit Modification Kit	OP03-110-1	008-446-610	Kilometers
		OP03-110-2	008-452-200	Statute miles
11	AC/DC Modification Kit	OP03-112-1	008-446-620	Converting AC to DC spec.
12	Interswitch	RJ-7		Switching for 4 scanners and 6 displays, under development
13	Remote Display			Under development
14	Radar Slave Display	CD-141		Color
		FMD-8000		Monochrome
		FMD-2100		Under development
15	Display Unit Cover	OP03-94	008-446-480	Tabletop, 2.5G7/2
		OP03-95	008-446-490	Tabletop, 7.5BG7/2
		OP03-96	008-446-500	Console, 2.5G7/2
		OP03-97	008-446-510	Console, 7.5BG7/2
16	Pedestal			For console type
17	Console Kit	OP03-122-1	000-085-711	2.5GY5/1.5
		OP03-122-2	000-085-712	2.5G7/2
		OP03-122-3	000-085-713	7.5BG7/2
18	Trans. Unit	RU-1803	000-030-420	440 V, 1 ϕ →100 V
		RU-5693	000-030-456	110 V, 3 ϕ →220 V, 60 Hz
		RU-6522	000-030-410	220 V, 3 ϕ →200 V, 50 Hz
		RU-5466-1	000-030-453	440 V, 3 ϕ →200 V, 50 Hz
		RU-3305	000-030-448	110/115/220 V→100 V

Appendix A – INITIALIZATION OF GYRO CONVERTER GC-8

Gyro Converter GC-8, incorporated inside the radar display unit, converts analog gyrocompass reading into digital coded bearing data for display on the radar display.

This appendix explains how to set up the GC-8 according to the make and specifications of the gyrocompass connected.

Connection of External Power Supply

Overview

Connect an external power supply when the repeater signal is step-by-step type and the step voltage is below 20 V or output voltage is less than 5 W.

Jumper wire

Remove jumper wire JP1 when connecting an external power supply. Refer to page A-9.

Connections

Connect gyrocompass cable and power cable as shown in Figure A-1.

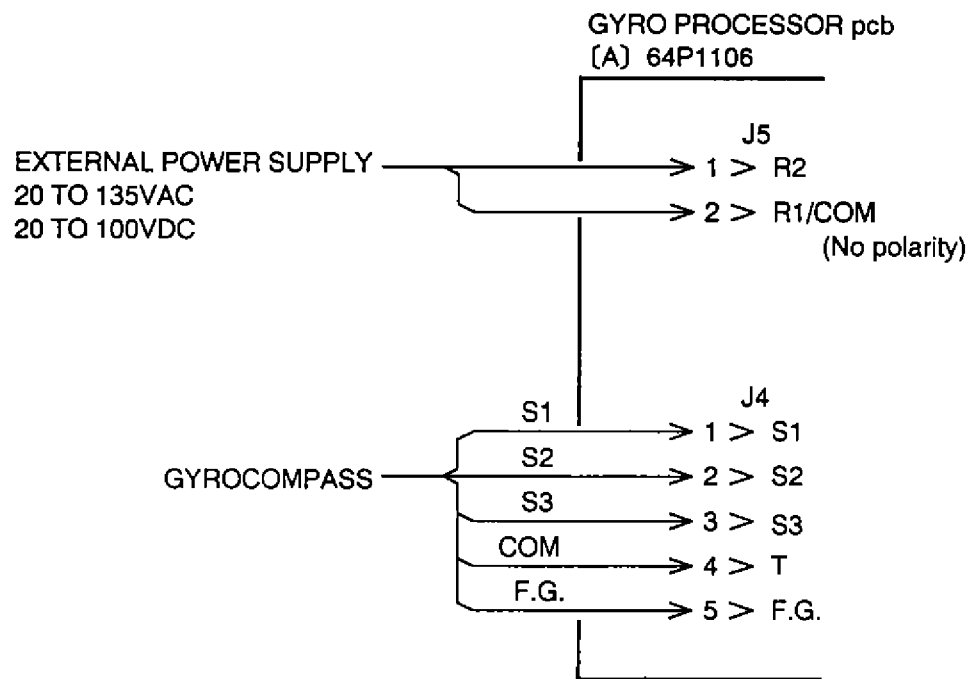

Figure A-1 Connection of external power supply

Setting of DIP Switches and Jumper Wires

Compatible gyrocompasses

The GC-8 is compatible with most gyrocompasses by means of its DIP switches and jumper wires on the GYRO PROCESSOR Board. Below are the gyrocompass specifications it can accommodate.

AC synchro

Frequency: 50/60 Hz, 400 Hz, 500 Hz
 Rotor Voltage: _____ VAC
 Stator Voltage: _____ VAC
 Gear Ratio: 360×, 180×, 90×, 36×

DC synchro

Rotor Voltage: _____ VDC
 Stator Voltage: _____ VDC
 Gear Ratio: 360×, 180×, 90×, 36×

DC step-by-step

Supply Voltage: _____ VDC
 Gear Ratio: 360×, 180×, 90×, 36×

Full- Half-wave pulsating step-by-step

Frequency: 50/60 Hz, 400 Hz, 500 Hz
 Supply Voltage: _____ VDC
 Gear Ratio: 360×, 180×, 90×, 36×

Full-wave pulsating current

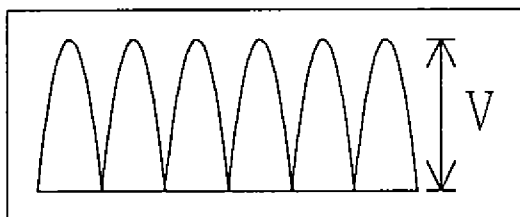

Half-wave pulsating current

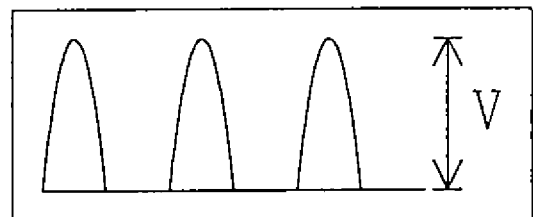

Default settings

In the default settings all DIP switches are off and all jumper wires are set to “#1”. (Note that jumper wire JP1’s setting is #1, #2, #3.) In those conditions the gyrocompass having the following specifications can be directly connected without further modification.

Gyrocompass: AC synchro
 Frequency: 50/60 Hz
 Rotor voltage: 60 to 135 VAC
 Stator voltage: 60 to 135 VAC
 Gear ratio: 360×
 Supply voltage: 30 to 135 VAC

Setting procedure

If the gyrocompass specifications differ from those shown above, set DIP switches and jumper wires as follows.

1) Gyrocompass type

Gyrocompass	SW1-4	SW1-5	SW1-6	JP1
AC Synchro	OFF	OFF	OFF	#1, #2, #3
DC Synchro	OFF	OFF	OFF	#2, #3, #4
DC step-by-step	ON	OFF	OFF	#4, #5, #6
Full-wave pulsating step-by-step	OFF	ON	OFF	#4, #5, #6
Half-wave pulsating step-by-step	ON	ON	OFF	#4, #5, #6

2) Frequency

Frequency	SW1-7	SW1-8	Remarks
50/60 Hz	OFF	OFF	AC synchro, pulsating step-by-step
400 Hz	ON	OFF	AC synchro, pulsating step-by-step
500 Hz	OFF	ON	AC synchro, pulsating step-by-step
DC	ON	ON	DC synchro, DC step

3) Rotor voltage (measured between R1 and R2)

This step is for the AC synchro gyrocompass. For DC synchro gyrocompass go to step 6.

Rotor Voltage	SW2-1	JP3
20 to 45 VAC	ON	#2
30 to 70 VAC	OFF	#2
40 to 90 VAC	ON	#1
60 to 135 VAC	OFF	#1

(continued on next page)

4) Stator voltage (measured between S1 and S2)

Stator Voltage	SW2-2	SW2-3	JP2
20 to 45 VAC or 20 to 60 VDC	ON	OFF	#2
30 to 70 VAC or 40 to 100 VDC	OFF	OFF	#2
40 to 90 VAC	ON	OFF	#1
60 to 135 VAC	OFF	OFF	#1

5) Gear ratio

Gear Ratio	SW1-1	SW1-2	SW1-3
360×	OFF	OFF	OFF
180×	ON	OFF	OFF
90×	OFF	ON	OFF
36×	ON	ON	OFF

6) Power supply voltage

Voltage	JP4	JP5
20 to 45 VAC or 20 to 60 VDC	#2	#2
30 to 135 VAC or 40 to 100 VDC	#1	#1

7) Data transmitting interval of NMEA 0183

Set according to specifications of equipment which is to receive A/D converter data.

Transmitting Interval	SW2-4
2 seconds	ON
1 second	OFF

8) Data transmitting interval of format AD-10

Select data transmitting interval of ports 1 to 6 by jumper wire JP6, JP7.

■ **NOTE:** *The transmitting interval is available in 25 msec or 200 msec. 25 msec is for radar only. 200 msec is for all other equipment.*

Setting by make and model of gyrocompass

The table below shows how to set the GC-8 for connection with various makes and models of gyrocompasses.

MANUFACTURER	MODEL	SPECIFICATIONS	SW1-1	SW1-2	SW1-3	SW1-4	SW1-5	SW1-6	SW1-7	SW1-8	SW2-1	SW2-2	SW2-3	JP1	JP2	JP3	JP4	JP5
FURUNO	GY-700	DC STEP-BY-STEP 100V 180x 5 WIRES OPEN COL- LECTOR COUPLING	ON	OFF	OFF	ON	OFF	OFF	ON	ON	-	OFF	OFF	#4, #5, #6	#2	-	#1	#1
ANSCHUTZ	STANDARD 2/3	AC SYNCHRO 50/60Hz ROTOR : 50/60V STATOR: 22V 360x	OFF	OFF	OFF	OFF	OFF	OFF	OFF	OFF	OFF	ON	OFF	#1, #2, #3	#2	#2	#1	#1
	STANDARD 4/6	AC SYNCHRO 50/60Hz ROTOR : 50/60V STATOR: 90V 360x	OFF	OFF	OFF	OFF	OFF	OFF	OFF	OFF	OFF	OFF	OFF	#1, #2, #3	#2	#1	#1	#1
YOKOKAWA NAVTEC (PLATH TYPE)	C-1/1A/2/3 A-5S, B-5S	AC SYNCHRO 50/60Hz ROTOR : 50/60V STATOR: 22V 360x	OFF	OFF	OFF	OFF	OFF	OFF	OFF	OFF	OFF	ON	OFF	#1, #2, #3	#2	#2	#1	#1
	CH2-100/200 C-Jr, D-1Z/1/3, 1PS-2/3	AC SYNCHRO 50/60Hz ROTOR : 100V STATOR: 90V 360x	OFF	OFF	OFF	OFF	OFF	OFF	OFF	OFF	OFF	OFF	OFF	#1, #2, #3	#1	#1	#1	#1
PLATH	NAVGAT 11/111	AC SYNCHRO 50/60Hz ROTOR : 50/60V STATOR: 68V 360x	OFF	OFF	OFF	OFF	OFF	OFF	OFF	OFF	OFF	OFF	OFF	#1, #2, #3	#2	#2	#1	#1
TOKIMEC (SPERRY TYPE)	ES-1/2/11 GL1-101/102/103/ 106K/107	AC SYNCHRO 50/60Hz ROTOR : 100/110V STATOR: 90V 96x	ON	ON	OFF	OFF	OFF	OFF	OFF	OFF	OFF	OFF	OFF	#1, #2, #3	#1	#1	#1	#1
	ES-11A TG-200 PR222R PR237L/H GM-21	AC SYNCHRO 50/60Hz ROTOR : 100/110V STATOR: 90V 90x	OFF	ON	OFF	OFF	OFF	OFF	OFF	OFF	OFF	OFF	OFF	#1, #2, #3	#1	#1	#1	#1
	MK-14 MOD-1/2/1 MK-EN, MK-E1	DC STEP-BY-STEP 70V 180x COM(-), 3 WIRES(+)	ON	OFF	OFF	ON	OFF	OFF	ON	ON	-	OFF	OFF	#4, #5, #6	#2	-	#1	#1
	SR-130/140	DC STEP-BY-STEP 70V 180x 5 WIRES OPEN COL- LECTOR COUPLING	ON	OFF	OFF	ON	OFF	OFF	ON	ON	-	OFF	OFF	#4, #5, #6	#2	-	#1	#1
	TG-100-5000 PR-357/130/140 ES17 GLT-201/202/203	DC STEP-BY-STEP 70V 180x COM(+), 3 WIRES(-)	ON	OFF	OFF	ON	OFF	OFF	ON	ON	-	OFF	OFF	#4, #5, #6	#2	-	#1	#1
	SR-120, ES-16, MK-20	DC STEP-BY-STEP 35V 180x COM(+), 3 WIRES(-)	ON	OFF	OFF	ON	OFF	OFF	ON	ON	-	ON	OFF	#4, #5, #6	#2	-	#2	#2
ARMABROWN	MK-10, MKL-1, SERIES 1351, MOD-4	DC STEP-BY-STEP 50V 180x COM(+), 3 WIRES(-)	ON	OFF	OFF	ON	OFF	OFF	ON	ON	-	OFF	OFF	#4, #5, #6	#2	-	#1	#1
ROBERTSON	SKR-80	DC STEP-BY-STEP 35V 180x COM(-), 3 WIRES(+)	ON	OFF	OFF	ON	OFF	OFF	ON	ON	-	ON	OFF	#4, #5, #6	#2	-	#2	#2

Function of DIP switches and jumper wires

The function of each DIP switch and jumper wire is as shown in the table which follows. Set them according to the specifications of the gyrocompass connected. After changing settings, turn off the power, or turn on and off SW2-8 to reset the CPU.

DIP switch SW1

Segment	Function	Setting
SW1-1, -2, -3	Gear ratio	<u>SW1-1</u> <u>SW1-2</u> <u>SW1-3</u>
		OFF OFF OFF 360×
		ON OFF OFF 180×
		OFF ON OFF 90×
SW1-4, -5, -6	Type of gyrocompass	<u>SW1-4</u> <u>SW1-5</u> <u>SW1-6</u>
		OFF OFF OFF AC synchro
		OFF OFF OFF DC synchro
		ON OFF OFF DC step
SW1-7, -8	Frequency	<u>SW1-7</u> <u>SW1-8</u>
		OFF OFF 50/60 Hz
		ON OFF 400 Hz
		OFF ON 500 Hz
		ON ON DC

DIP switch SW2

Segment	Function	Setting
SW2-1	Rotor voltage	<u>SW2-1</u>
		ON 20 to 45 VAC
		OFF 30 to 70 VAC
		ON 40 to 90 VAC
SW2-2, -3	Stator voltage	<u>SW2-2</u> <u>SW2-3</u>
		ON OFF 20 to 45 VAC
		OFF OFF 30 to 70 VAC
		ON OFF 40 to 90 VAC
SW2-4	NMEA0183 output interval	<u>SW2-4</u>
		ON 2 seconds
		OFF 1 second
		OFF OFF 60 to 135 VAC
SW2-5	Self test	<u>SW2-5</u>
		ON self test on
		OFF self test off
		ON OFF 20 to 60 VDC
SW2-6, -7	Not used	
SW2-8	CPU reset	normally off; turn on and off to reset CPU.

Jumper wire JP1

Segment	Function	Setting
#1, #2, #3	Type of gyrocompass	AC synchro
#2, #3, #4		DC synchro
#4, #5, #6		DC step

Jumper wire JP2

Segment	Function	Setting
#2	Stator voltage	20 to 70 VAC, or 20 to 100 VDC
#1		40 to 135 VAC

Jumper Wire JP3

Segment	Function	Setting
#2	Rotor voltage	20 to 70 VAC
#1		40 to 135 VAC

Jumper Wire JP4

Segment	Function	Setting
#2	Supply voltage	20 to 45 VAC, or 20 to 60 VDC
#1		30 to 135 VAC or 40 to 100 VDC

Jumper Wire JP5

Segment	Function	Setting
#2	Supply voltage	20 to 45 VAC, or 20 to 60 VDC
#1		30 to 135 VAC, or 40 to 100 VDC

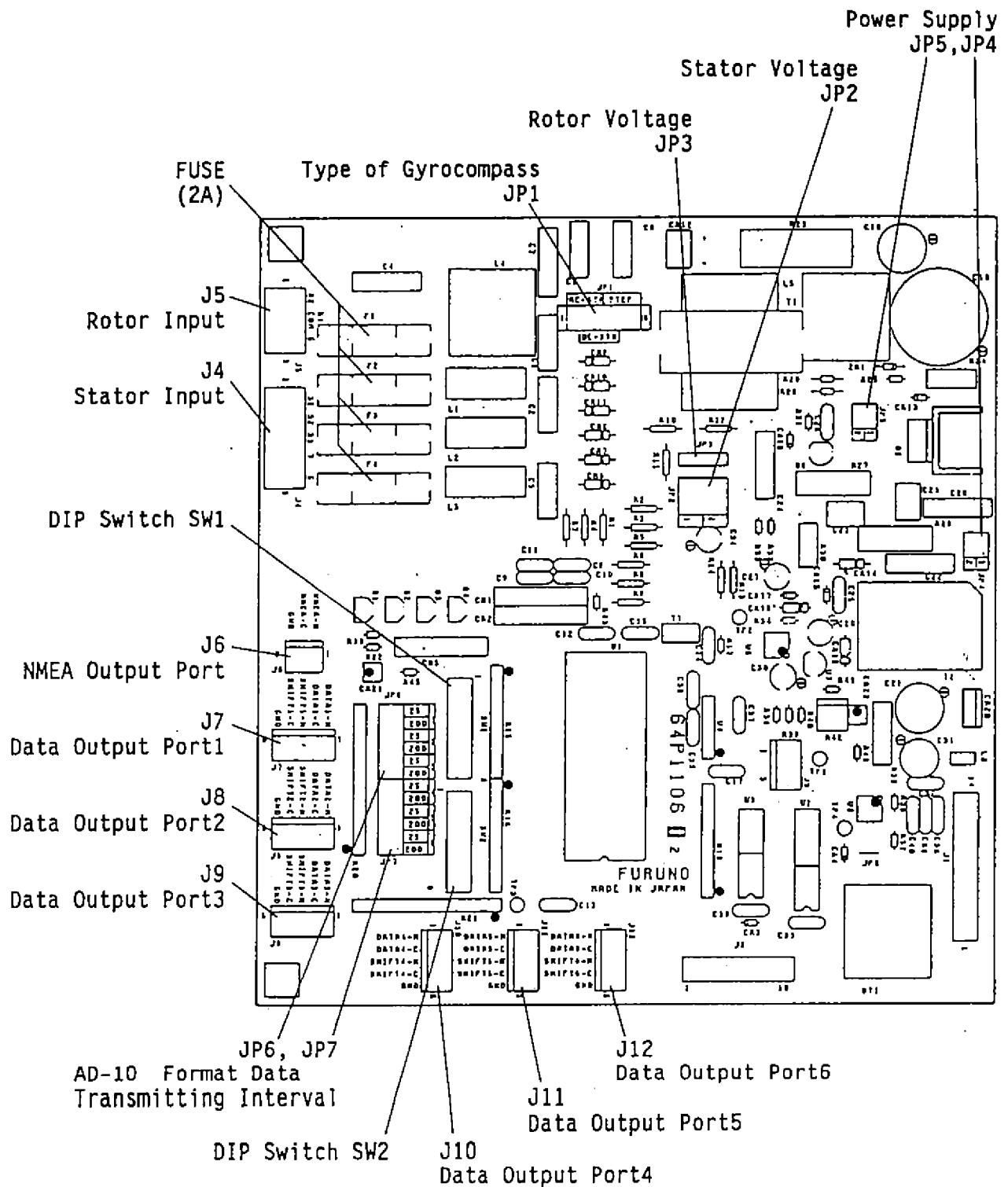

Figure A-2 GYRO PROCESSOR Board

Setting of Bearing

Procedure

Confirm that the gyrocompass is giving reliable readings. Then, set bearing on the radar display as shown in the procedure below. Once you set the bearing, re-setting of it is not usually required. However, always check the reading for accuracy before embarking. If it is in error, correct it by [+] and [-] in the top panel on the display unit.

- 1) Open the top panel on the display unit. Press the HOLD switch to disengage the computing circuit from the gyrocompass. The "HOLD" LED lights.
- 2) Press [+]/[-] switches to duplicate the gyrocompass reading at the top of the radar display. (Each press of those switches changes the readout by 0.1 degrees. Press and hold down one of the switches more than two seconds to change the readout by one degree.)
- 3) Press the HOLD switch when the gyrocompass reading on the radar matches the gyrocompass reading. The "HOLD" LED extinguishes.

■ **NOTE:** *In some cases, the gyrocompass rotation may be the opposite of the displayed bearing, in spite of correct connections. In this case try exchanging two connections among S1, S2 and S3 on the GYRO SWITCH Board.*

Appendix B – INSTALLING GYRO CONVERTER GC-8

Overview

The GC-8 is installed inside the display unit of the radar, by means of the GC-8 Kit. The contents of the kit are as follows.

Name	Type	Code No.	Qty
GYRO PROCESSOR Board Assy.	[A]64P1106	004-412-220	1

Connections

Cables 1 and 2 below are factor-wired inside the display unit. Multi-core cable, MPYC-5 should be arranged locally. NH connector assemblies are included in display installation materials.

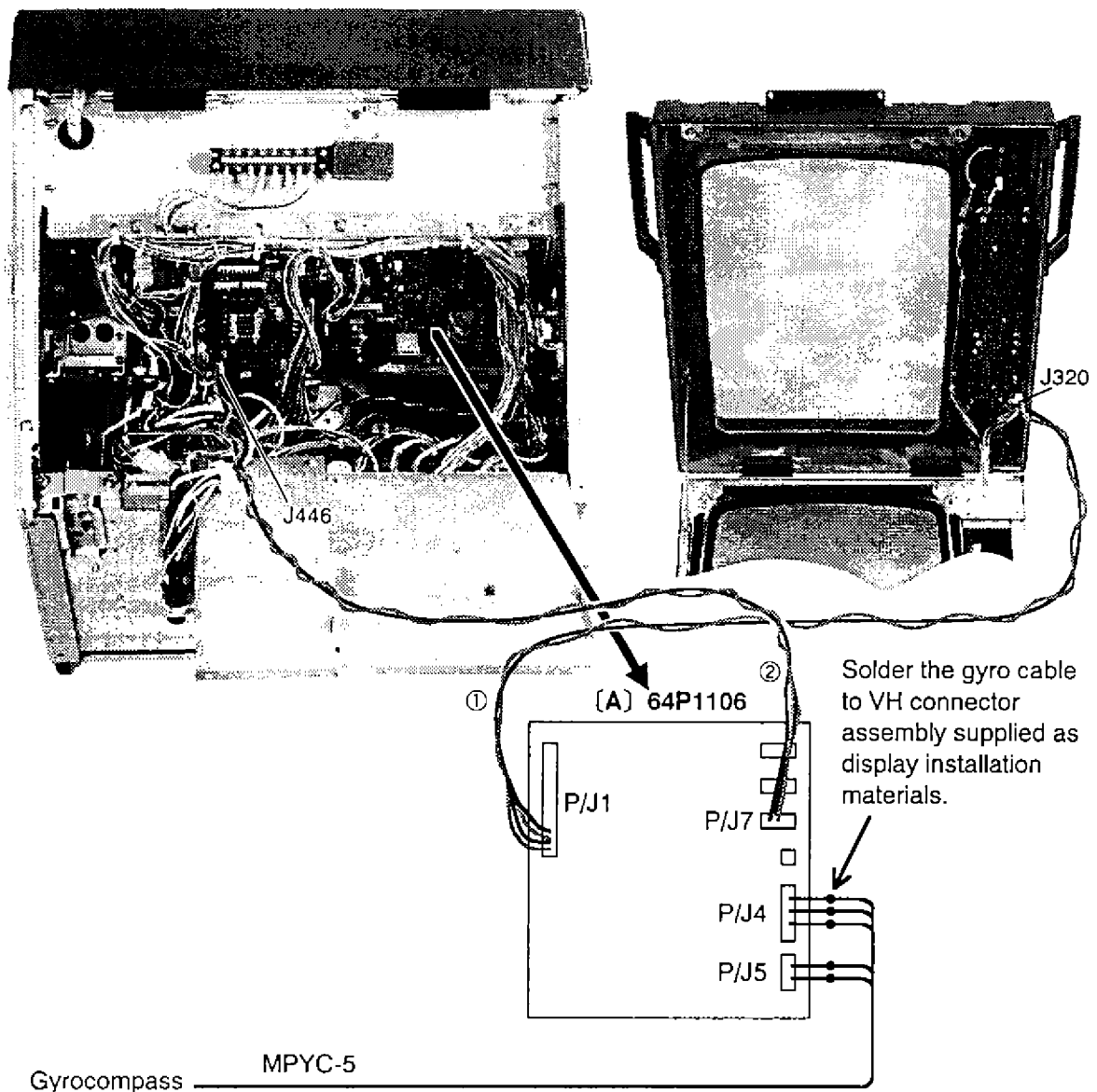

Figure B-1 Installation of GC-8

TABLE OF DRAWINGS

Name	Drawing No.	Page
OUTLINE DRAWINGS		
DISPLAY UNIT (tabletop)	C3382-G01	D-1
DISPLAY UNIT (console type)	C3382-G02	D-2
DISPLAY UNIT (tabletop, separate control unit)	C3382-G06	D-3
CONTROL UNIT	C3382-G05	D-4
POWER SUPPLY UNIT (SPU-004)	C3385-G02	D-5
SCANNER UNIT	C3311-011	D-6
TRANSFORMER UNIT (RU-1758/1803)	C3003-001	D-7
TRANSFORMER UNIT (RU-5466-1/6764/5693)	C3003-006	D-8
TRANSFORMER UNIT (RU-6347/6522)	C3003-007	D-9
TRANSFORMER UNIT (RU-3305)	C3003-004	D-10
INTERCONNECTION DIAGRAMS		
INTERCONNECTION DIAGRAM (1/2)	C3387-C01	S-1
INTERCONNECTION DIAGRAM (2/2)	C3387-C02	S-2
FR-2130S (AC specification)	E3387-D01	S-3
FR-2130S (DC specification)	E3387-D02	S-4
CIRCUIT DIAGRAMS		
DISPLAY UNIT (AC specification)	C3382-K01	S-5
DISPLAY UNIT (DC specification)	C3382-K02	S-6
SCANNER UNIT	C3311-010	S-7
POWER SUPPLY UNIT (SPU-004)	C3385-K01	S-8

- 注 記 1) 装置ケーブルはケーブルレス時、指示器を前方に充分引き出すよう注意を怠らざること。
 2) 取付用ネジはM10ボルトまたはM10ボルト呼び径φ9を使用のこと。
 3) 取付寸法は最小ケーブル空間寸法とする。

- NOTE 1) SUFFICIENT EXTRA CABLING SHOULD BE ALLOWED AT THE BACK OF THE UNIT SO THAT THE UNIT CAN BE DRAWN OUT WITH THE CABLES CONNECTED FOR MAINTENANCE.
 2) USE M10 BOLTS OR φ9 COACH SCREWS FOR FIXING THE UNIT.
 3) # : RECOMMENDED SERVICING CLEARANCE

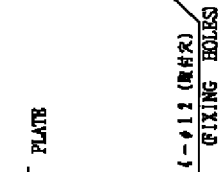
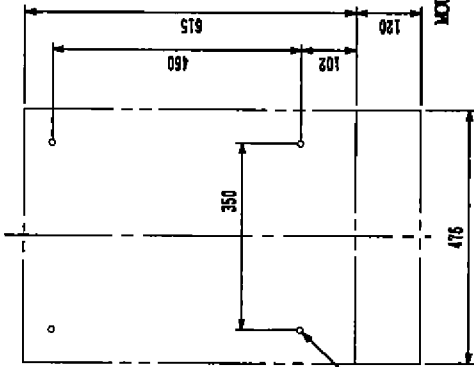

取付寸法図 (全長 A)
 MOUNTING DIMENSION (VIEWING A)

パネルオープン時
 WHEN PANEL IS OPENED

パネル完全に開いたとき (全開時)
 PANEL FULLY OPENED FOR MAINTENANCE
 STAY REMOVED

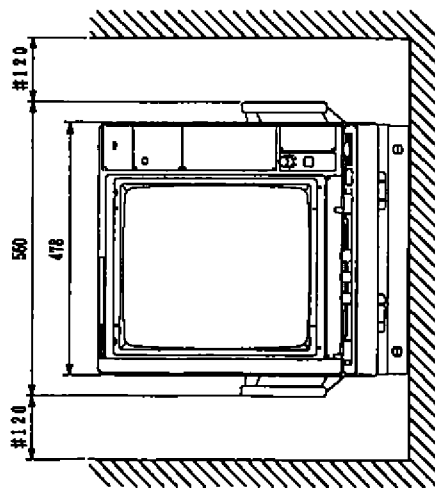
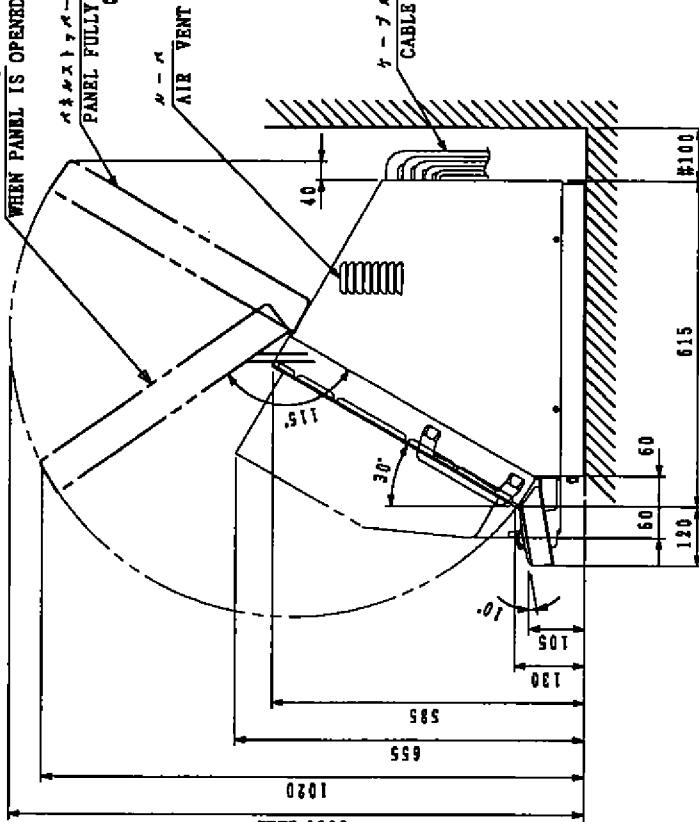

A ↓

DESKIN No. 18 77	FR-2110/2120/2120W	TITLE	RDP-106
CHECKED I. S. H. / S. A. L.	FR-2130B/2130BW	名番	指示部 (桌上据付)
CHKD. No. 17	FR-2160/2160W	外寸図	
APPROVED I. S. H. / S. A. L.	FR-2160DE/2160DW	NAME	DISPLAY UNIT (TABLETOP MOUNT)
APPROVED No. 17 1979	FR-2120Z	SCALE	1/50
SCALE MASS 56 kg		DMCNA	C3382-G01-G
		OUTLINE DRAWING	

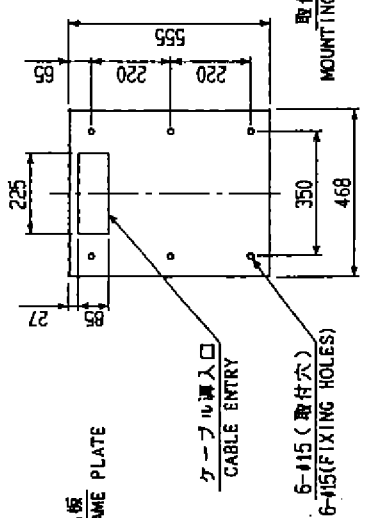

取付寸法図 (実図 A)
MOUNTING DIMENSION (VIEWING A)

パネルオープン時
WHEN PANEL IS OPENED

パネルストッパー取り外し時 (全開時)
PANEL FULLY OPENED FOR MAINTENANCE
(STAY REMOVED)

表 1
TABLE 1

範囲	公差
L ≤ 50	±1mm
50 < L ≤ 100	±2mm
100 < L ≤ 500	±3mm
500 < L ≤ 1000	±4mm
1000 < L ≤ 2000	±5mm
2000 < L ≤ 4000	±7mm
4000 < L ≤ 8000	±10mm
8000 < L	±15mm

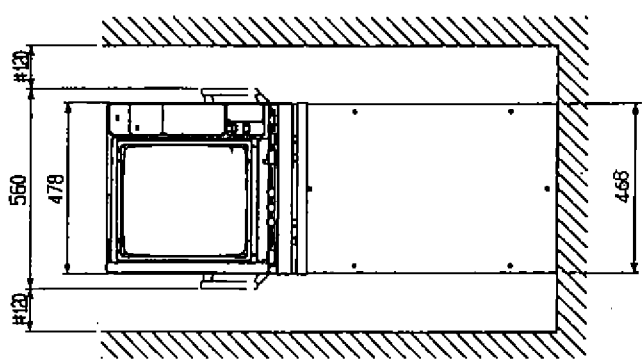

A ↓

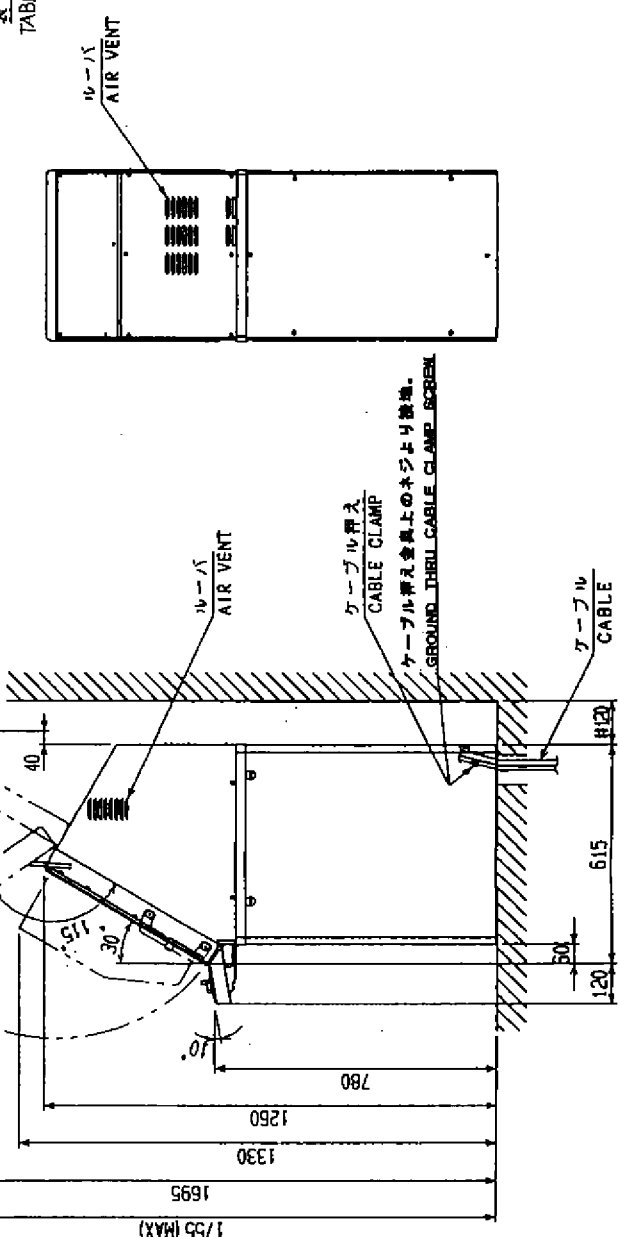

- 注 記
- 1) 鉄線ケーブルの端部処理は 装置要領書参照のこと。
 - 2) 取付用ネジはM12ボルトまたはコーナボルト呼び径12を使用のこと。
 - 3) #15取付穴は最小ケーブル径より径1mm空けを要する。
 - 4) 指定外の寸法公差は、表1による
- NOTE
- 1) REFER TO INSTALLATION INSTRUCTIONS FOR CABLE TERMINATION PROCEDURE.
 - 2) USE M12 BOLTS OR #12 COACH SCREWS FOR FIXING THE UNIT.
 - 3) #: RECOMMENDED SERVICING CLEARANCE.
 - 4) TABLE 1 SHOWS TOLERANCE OF DIMENSIONS.

図番	FR-2160DS/SW	型式	RDP-106
作成者	May 73 97 T. YAMASAKI	名称	指示器 (コンソール型)
承認者	May 73 97 K. KUSURIBE	外寸図	
スケール	1:1	図名	DISP. UNIT (CONSOLE TYPE)
縮尺	7.9 倍	図番	
縮尺	7.9 倍	図名	

- 注 記
- 1) 設置ケーブルはサービstime時、指示部を前方に充分引き出せるよう余裕を持たせること。
 - 2) 取付用ボルトはM10ボルトまたはコーナボルト呼び径φ9を使用のこと。
 - 3) 取付寸法は最小サービstime空間寸法とする。

NOTE

- 1) SUFFICIENT EXTRA CABLINGS SHOULD BE ALLOWED AT THE BACK OF THE UNIT SO THAT THE UNIT CAN BE DRAWN OUT WITH THE CABLES CONNECTED FOR MAINTENANCE.
- 2) USE M10 BOLTS OR φ9 CORNER BOLTS FOR FIXING THE UNIT.
- 3) # : RECOMMENDED SERVICING CLEARANCE.

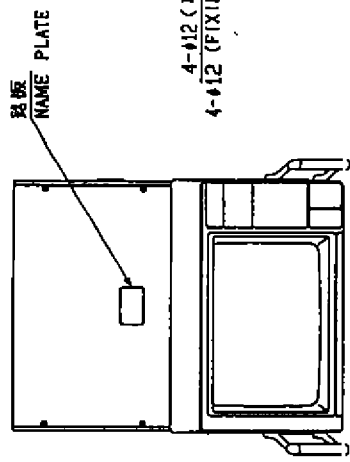
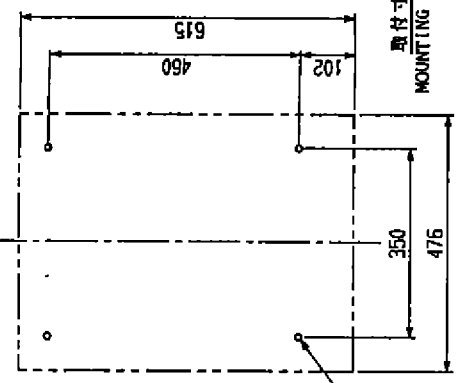

パネルオープン固定時
WHEN PANEL IS OPENED

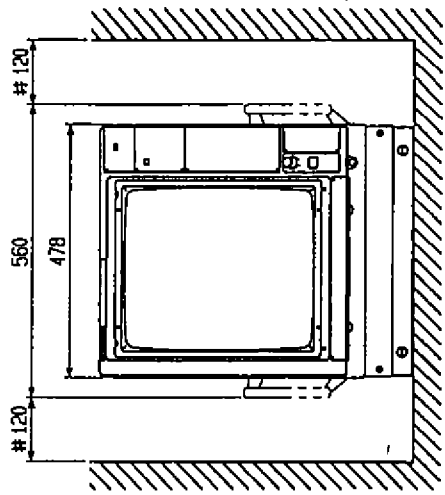
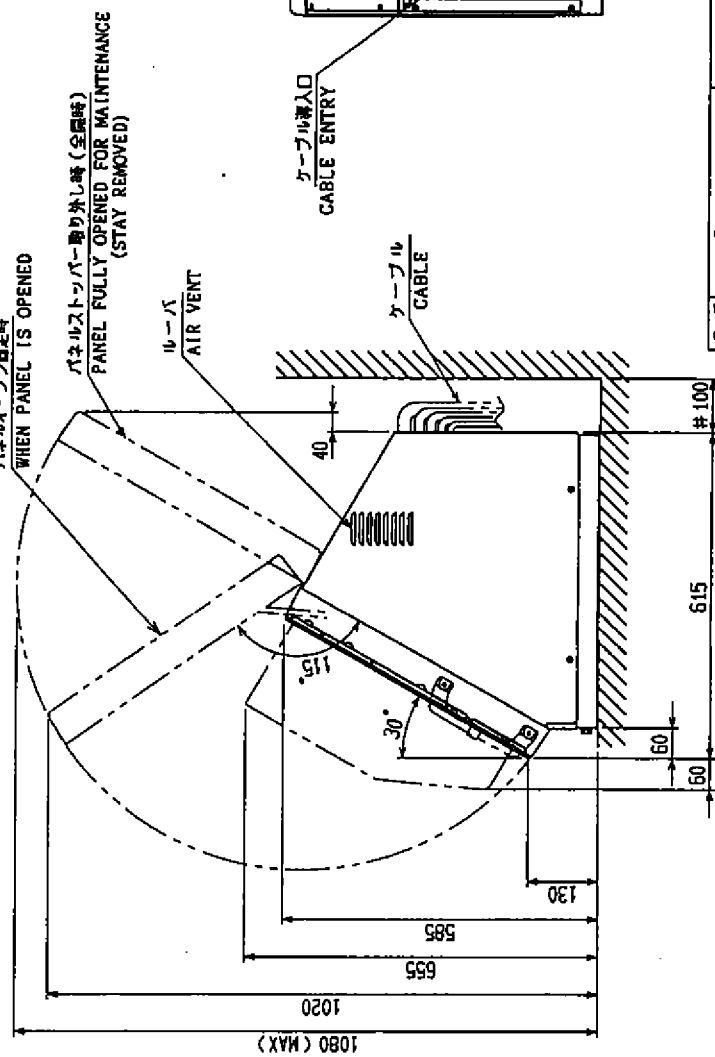

品番 (ITEM)	品名 (NAME)	材質 (MATERIAL)	取付 (TY)	図番 (DWG. NO.)	補遺 (REMARKS)
JUL-20-93	指示部 (卓上型パネル分離型)	RDP-106			
APPROVED	THIRD ANGLE PROJECTION				
H. M. A. J. O. A. W. L.					
JUL-20-93	SCALE				
Y. TANABE	WEIGHT				
JUL-18-93	54 : kg				
Y. TANABE					

- FR-2110
- FR-2120
- FR-2120W
- FR-2130S
- FR-2130SW
- FR-2150
- FR-2150W
- FR-2160DS
- FR-2160SW

図番 DWG. NO. C3382-G06-D

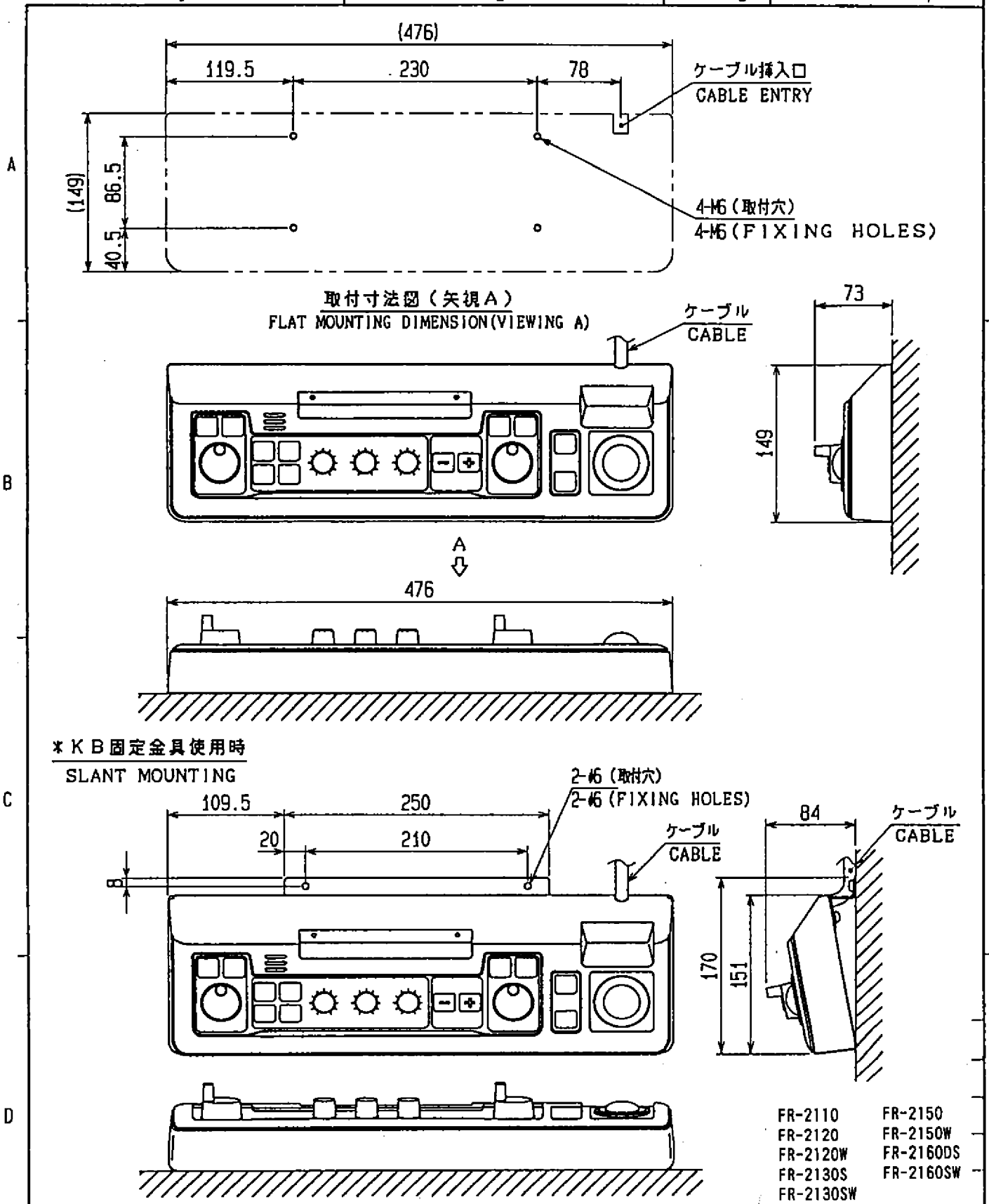

* KB固定金具使用時

SLANT MOUNTING

- FR-2110
- FR-2120
- FR-2120W
- FR-2130S
- FR-2130SW
- FR-2150
- FR-2150W
- FR-2160DS
- FR-2160SW

品番 ITEM	品名 NAME	材質 MATERIAL	数量 Q'TY	図番 DWG.NO.	補記 REMARKS
承認 APPROVED	JUL. 20. '93 H. Motoshi	三角法 THIRD ANGLE PROJECTION		名称 TITLE	
検図 CHECKED	JUL. 20. '93 M. Shibata	尺度 SCALE	1 / 5	RDP-106 操作部 (指示部操作パネル) DISPLAY CONTROL PANEL	
製図 DRAWN	JUL. 16. '93 Y. TANABE	重量 WEIGHT	2.5 kg	図番 DWG.NO. C3382-G05-C	

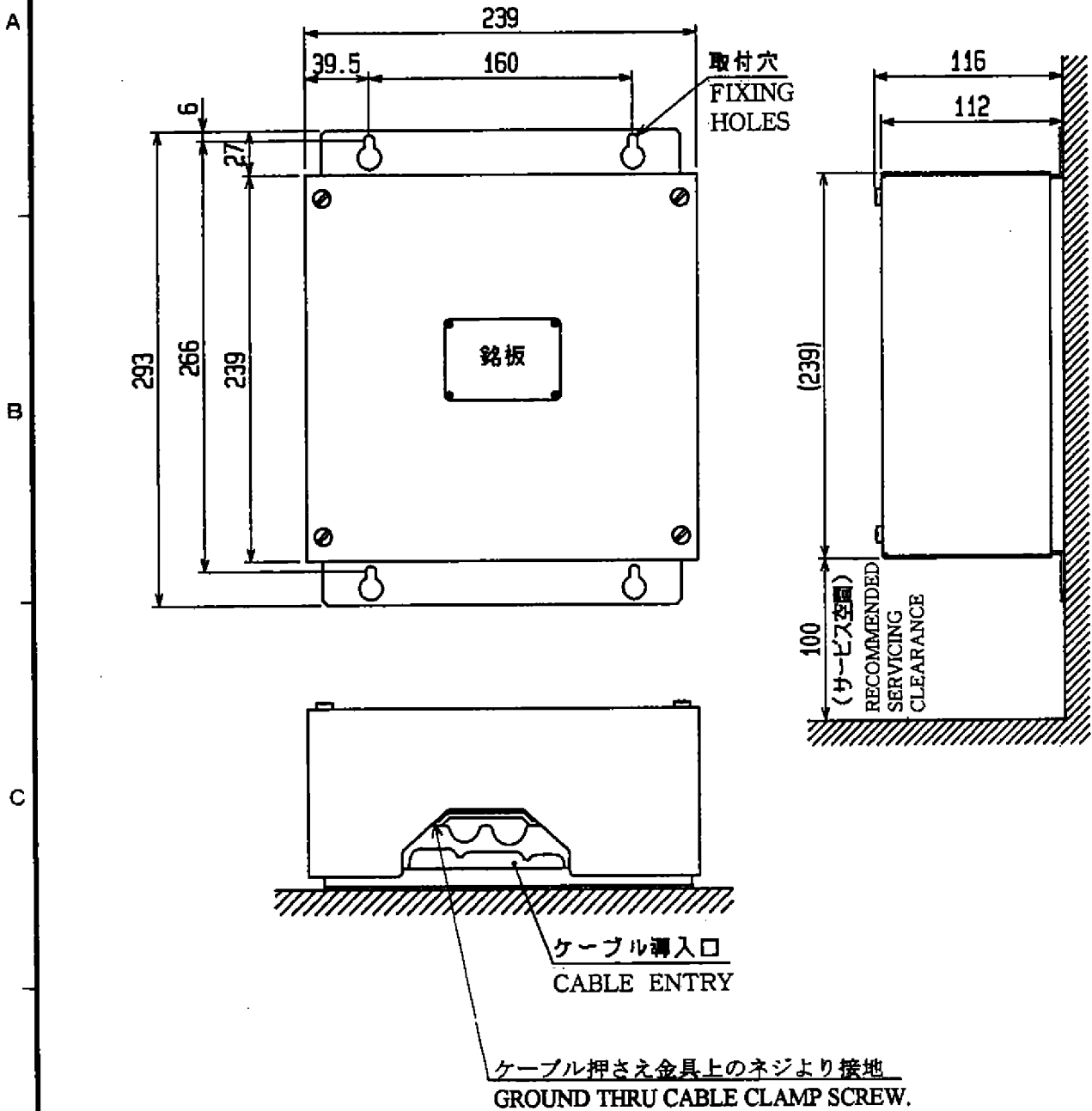

注 記：取付ネジは+トラスタップピンネジ呼び径5×20を使用のこと

NOTE: FIX THE UNIT BY USING FOUR TAPPING SCREWS (φ5×20).

DRAWN Nov. 13 '97 T. YAMASAKI	FR-2160SW FR-2160DS		TYPE PSU-004
CHECKED Nov. 13 '97 K. HISAWAKI	FR-2150/W FR-2130SW		名称 電源制御部
APPROVED Nov. 13 '97 H. YAMASAKI	FR-2130S FR-2120W		外寸図
SCALE 1/4 MASS 2.3kg	APPLICABLE TO; (MODEL)	BLOCK NO.	NAME POWER SUPPLY UNIT
DWG NO. C3385-G02-B			OUTLINE DRAWING

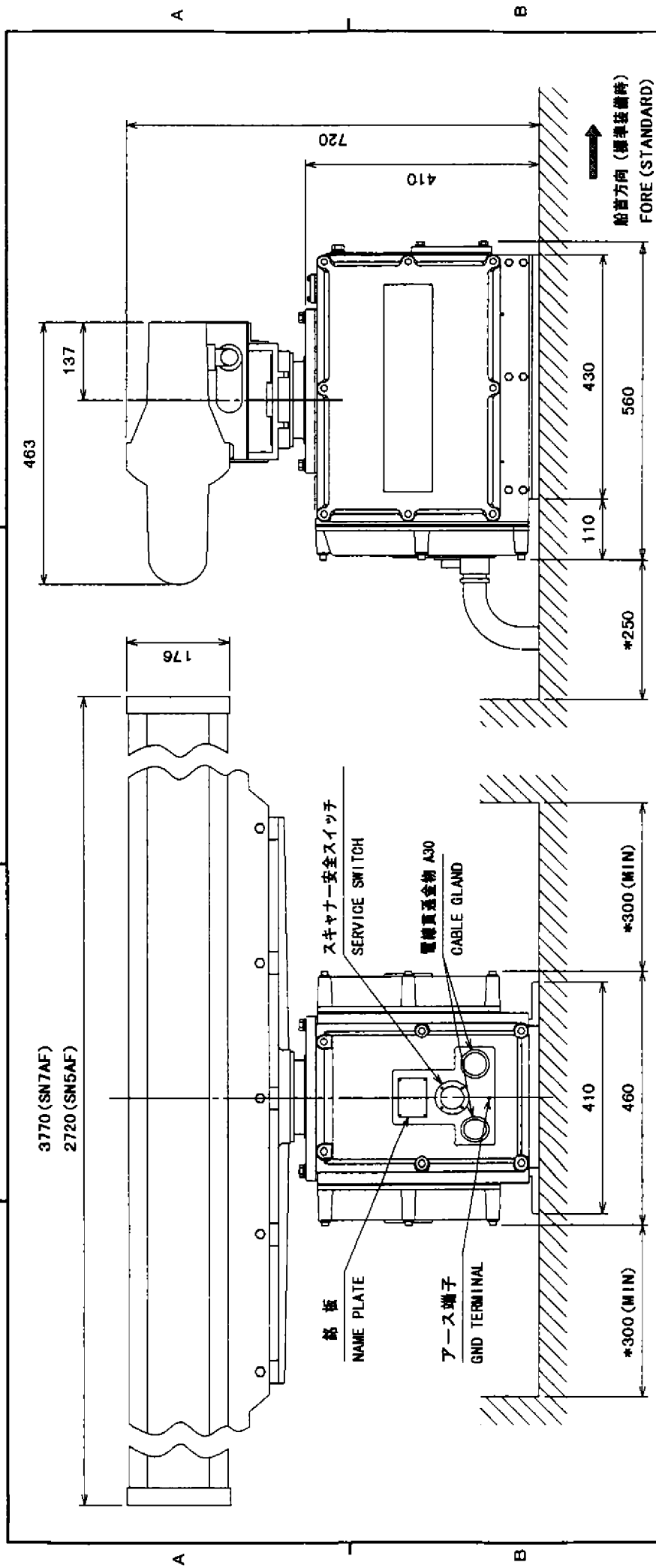

電 図	DIMENSIONS	公差 TOL.
L	500	± 1 mm
S	100	± 2 mm
L	500	± 3 mm
S	1000	± 4 mm
L	1000	± 5 mm
S	2000	± 7 mm
L	4000	± 10 mm
S	8000	± 15 mm

表 1
TABLE 1

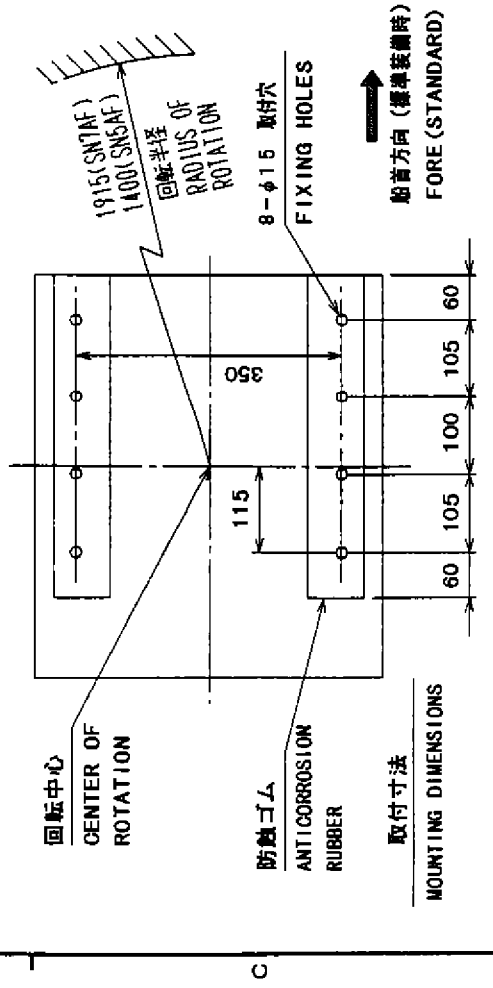

注記 NOTE: 1) *印寸法は推奨サービスマン空間を示す
*MARK SHOWS RECOMMENDED SERVICING CLEARANCE.
2) 指定外の寸法公差は表 1 による
TABLE 1 SHOWS TOLERANCE OF DIMENSIONS.
3) 設板プレートホーム (取付板) の板厚は 15mm 以上とする。
MOUNTING PLATE SHOULD BE 15mm THICK OR MORE.

アンテナ ANTENNA	SN7AF	SN5AF
質量 MASS	135Kg	125Kg

DRAWN: Feb 13 1981 J. Nakahara
CHECKED: Feb 13 1981 K. Kawasaka
APPROVED: Feb 14 1981 S. Yamaguchi
SCALE: 1/10

TITLE: RSB-0026 / RSB-0031
名 称: 空中線部
外寸図

NAME: SCANNER UNIT

Doc. No.: C3311-001-B 03-015-3000-60

OUTLINE DRAWING

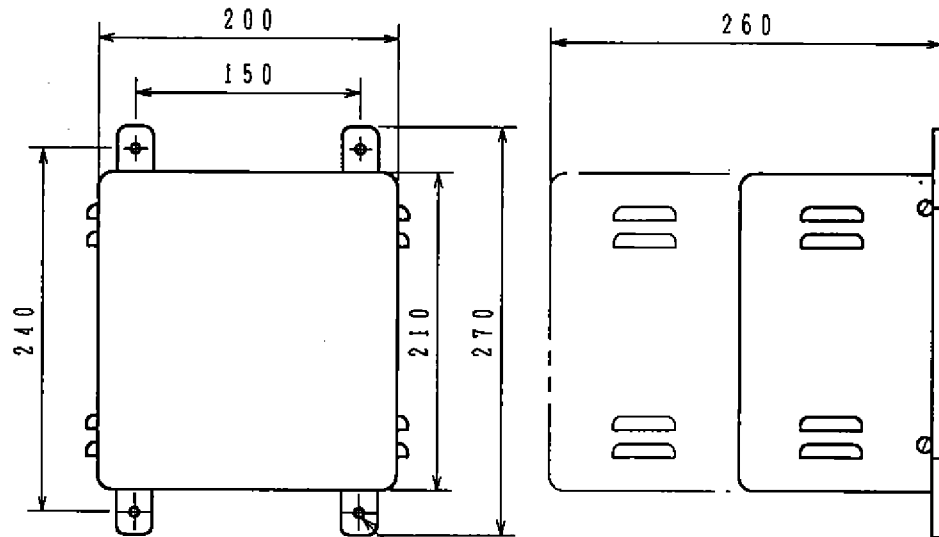

取付穴
4- ϕ FIXING HOLES

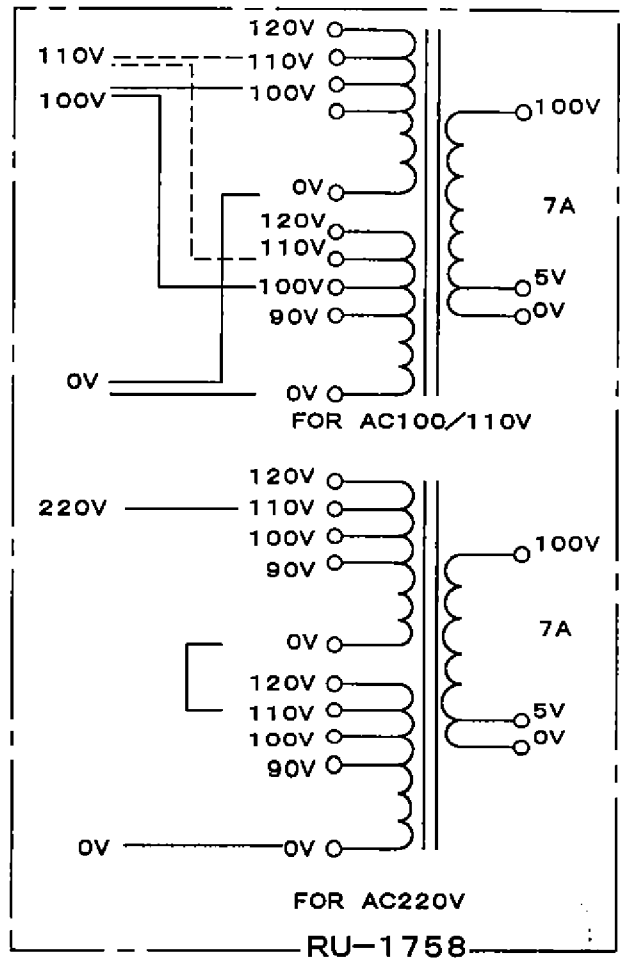
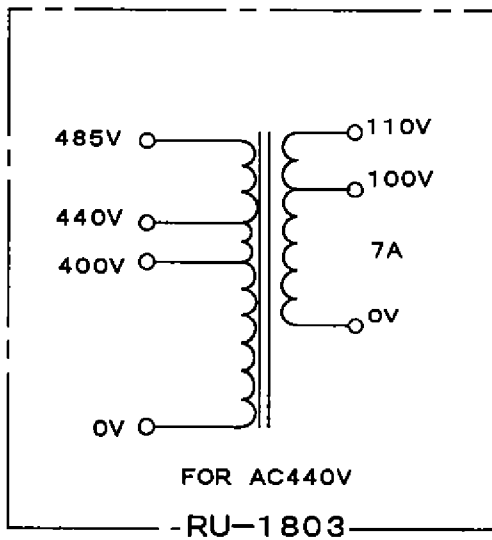
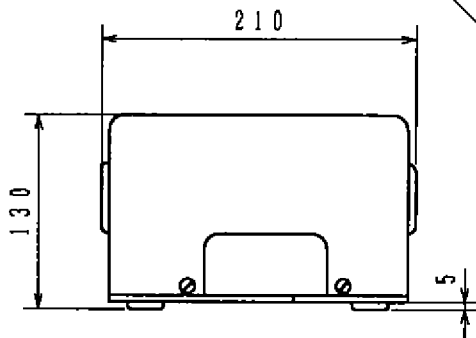

DRAWN June 19 '96 Y. EBISU		TITLE RU-1758/1803
CHECKED June 18 '96 K. Kusunoki		名称 トランスユニット
APPROVED June 18 '96 K. VTA		外寸図
SCALE 1/5 MASS 12 kg		NAME TRANSFORMER UNIT
DWG No. C3003-001-D		

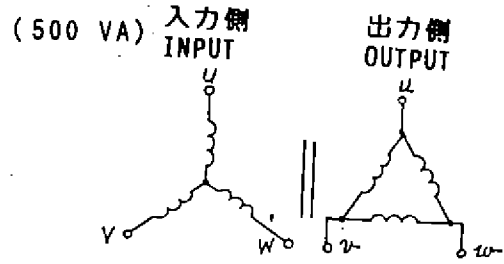
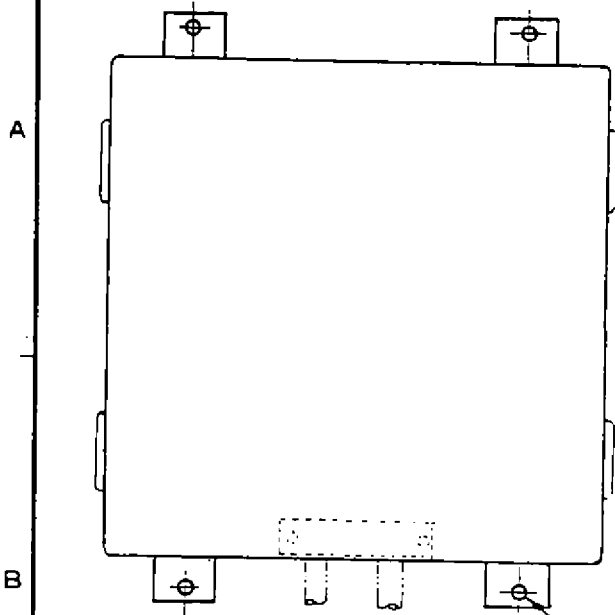

RU-5466-1	AC440V 3φ 50/60Hz	AC220V 3φ 60Hz	AC200V 3φ 50Hz
RU-6764	AC380V 3φ 50Hz	AC200V 3φ 50Hz	
RU-5693	AC110V 3φ 60Hz	AC220V 3φ 60Hz	

4-φ7

210

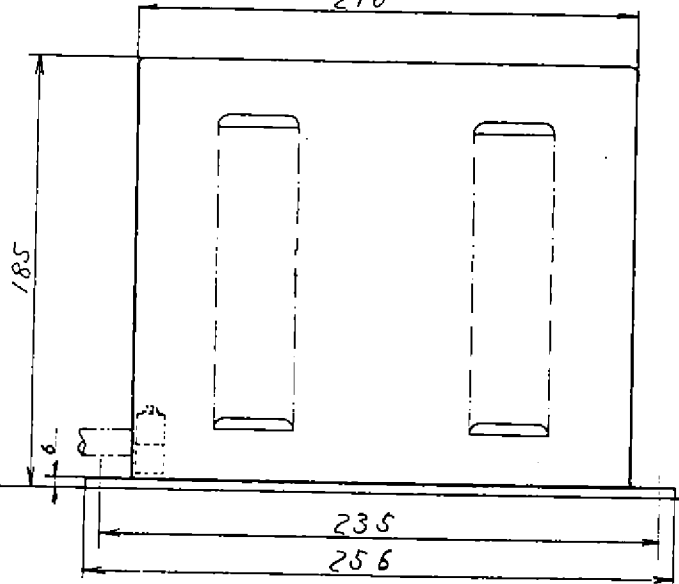
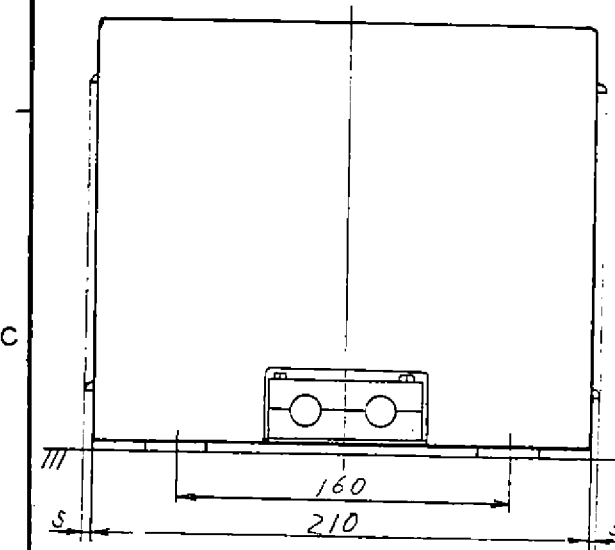

111
S

品番 ITEM	品名 NAME	材質 MATERIAL	数量 Q'TY	図番 DWG.NO.	摘要 REMARKS
承認 APPROVED	58.7.15 池谷	三角法 THIRD ANGLE PROJECTION		名称 TITLE	RU-5466-1
検査 CHECKED	58.8.11 不矢	尺度 SCALE	約 12 kg	トランスユニット TRANSFORMER UNIT	RU-6764 RU-5693
製図 DRAWN		重量 WEIGHT	約 12 kg	図番 DWG.NO.	C3003-006-E

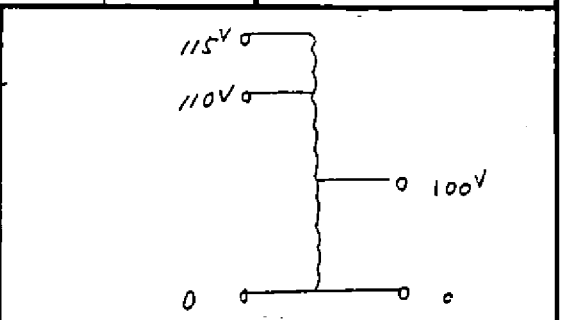
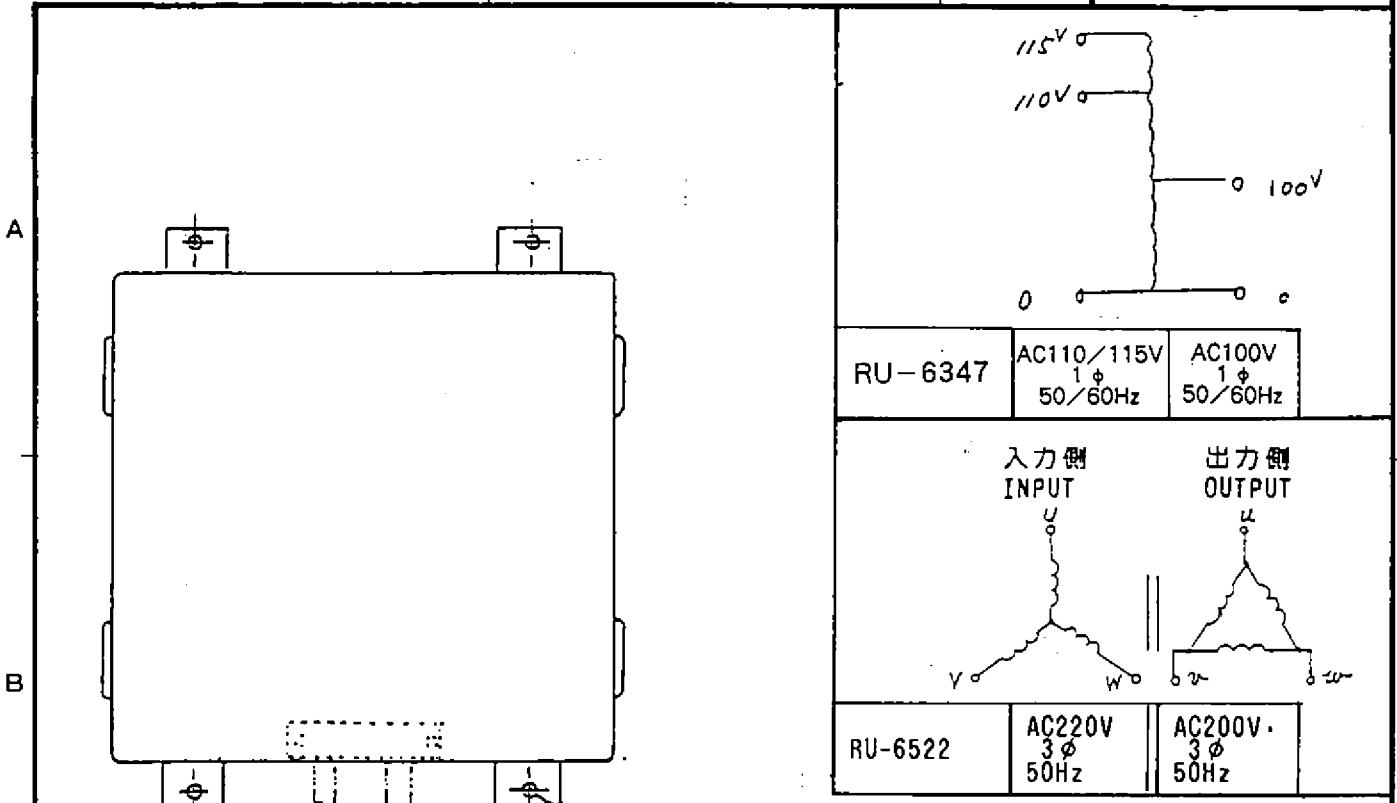

RU-6347	AC110/115V 1φ 50/60Hz	AC100V 1φ 50/60Hz
---------	-----------------------------	-------------------------

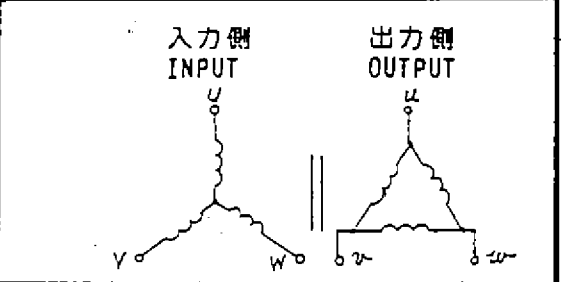

RU-6522	AC220V 3φ 50Hz	AC200V 3φ 50Hz
---------	----------------------	----------------------

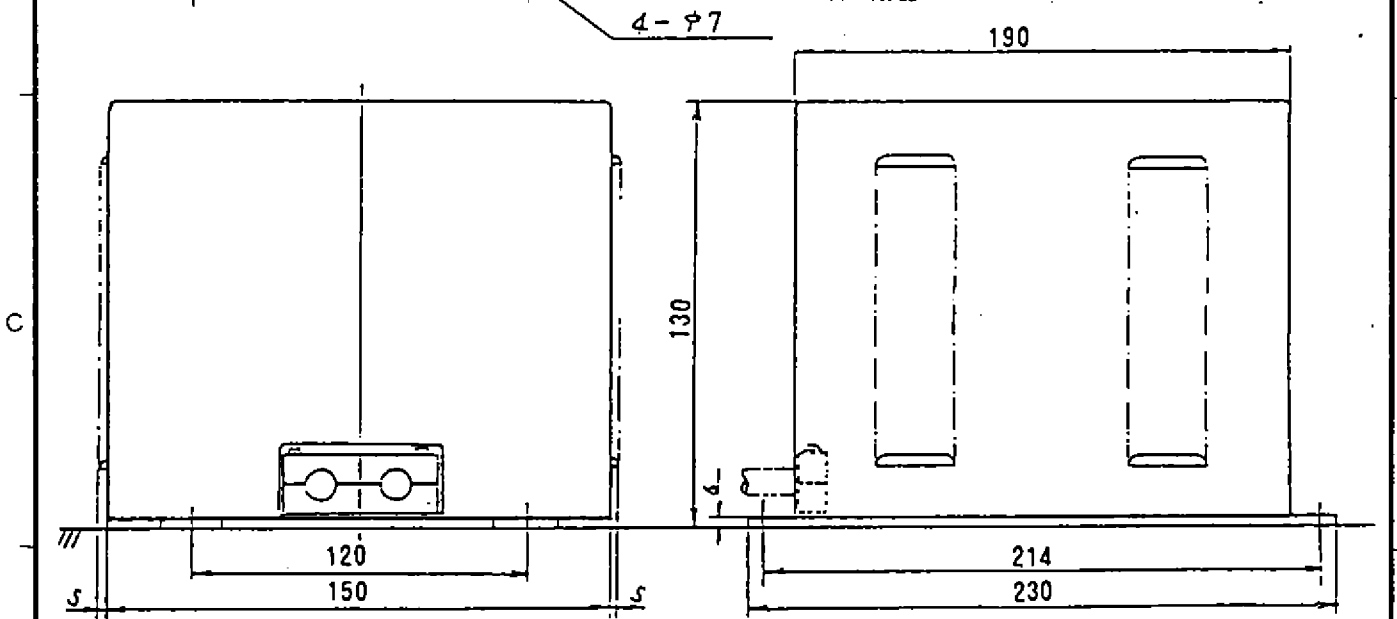

FR-1222/1222X/1622/1622X
FR-1252X/1652X
FAR-1622X/1652X

承認 APPROVED	品番 ITEM	品名 NAME	材質 MATERIAL	数量 Q'TY	図番 DWG.NO.	摘要 REMARKS
JUNE 2 '87 T. YAKANO		三角法 THIRD ANGLE PROJECTION				名称 TITLE RU-6347 トランスユニット RU-6522 TRANSFORMER UNIT
検図 CHECKED	JUNE 2 '87 T. YAKANO	尺度 SCALE				
製図 DRAWN		重量 WEIGHT	約12kg kg		図番 DWG.NO.	C3003-007-B

A
B
C
D

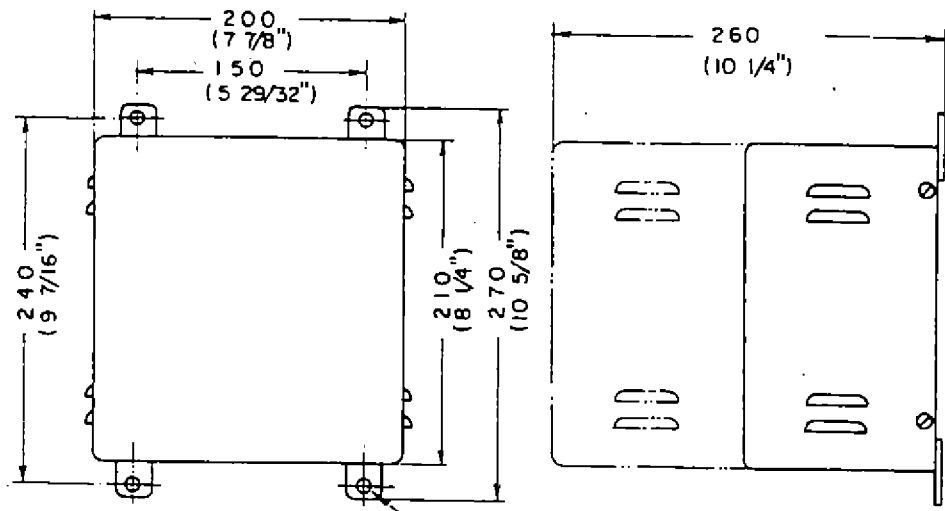

取付穴 4-7φ (17/64") FIXING HOLE

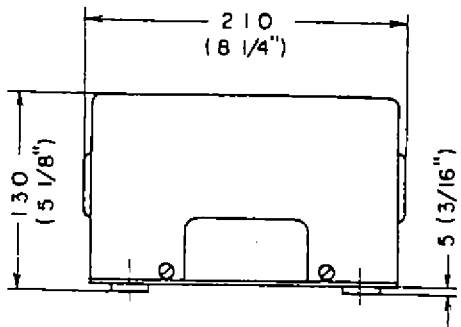

重量 WEIGHT: 12kg (27 lbs)
 単位 UNIT: mm (inches)

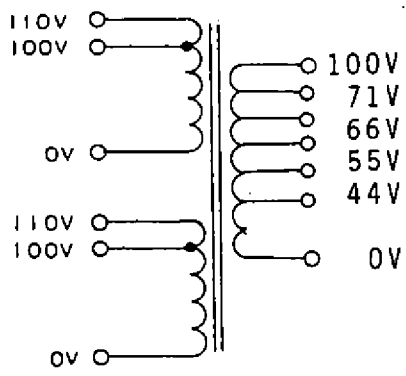

コンパス安全距離 COMPAS SAFE DISTANCE

スタンダード STANDARD	2.1 M
ステアリング STEERING	1.5 M

氷結防止 DE-ICER		品番 ITEM	品名 NAME	材質 MATERIAL	数量 Q'TY	図番 DWG.NO.	摘要 REMARKS
承認 APPROVED		三角法 THIRD ANGLE PROJECTION		名称 TITLE			
検図 CHECKED	Aug. 19. 83	尺度 SCALE	/	トランスユニット RU-3305 TRANSFORMER UNIT			
製図 DRAWN	19. Aug. 83 K.K.	重量 WEIGHT	12.2 kg	図番 DWG.NO. C3003-004-C			

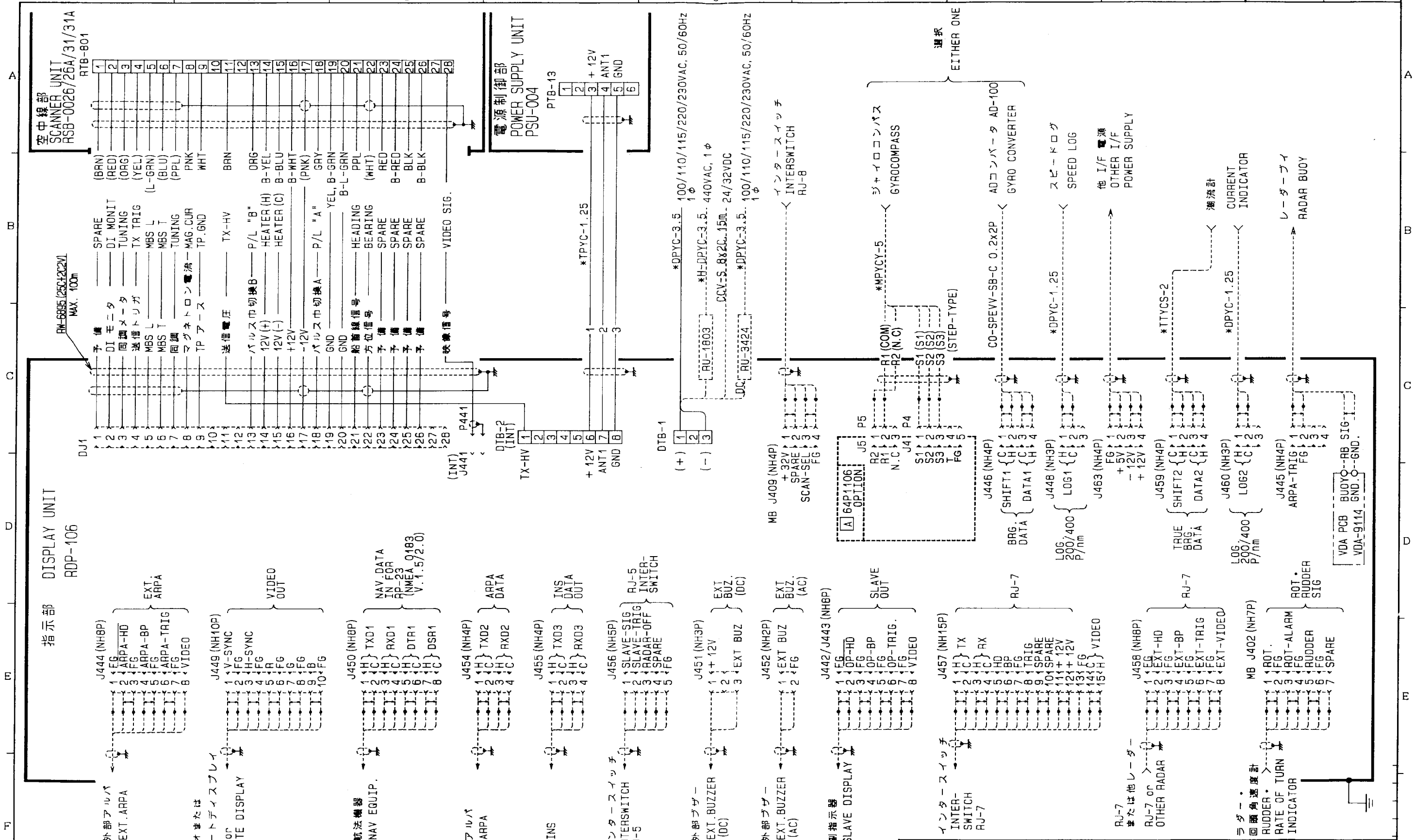

注記
 1. () 内は内側シールド内の線を示す。
 2. シールドは両ユニット側で完全にアースすること。
 3. * : 造船所支給 (現地手配)

NOTE
 1. WIRES IN () ARE INNER WIRES.
 B : LARGE WIRE, L : LIGHT COLOR.
 2. SHIELD SHOULD BE EFFECTIVELY GROUNDED AT BOTH UNIT ENDS.
 3. PREPARE LOCALLY.

FR-2130S

承認 APPROVED	May. 11. '94 IKEDA	名称 TITLE	相互結線図 (指示部) INTERCONNECTION (1/2)
検閲 CHECKED	May. 11. '94 MORIMOTO	製図 DRAWN	番 DWG. NO. C3387-C01-C

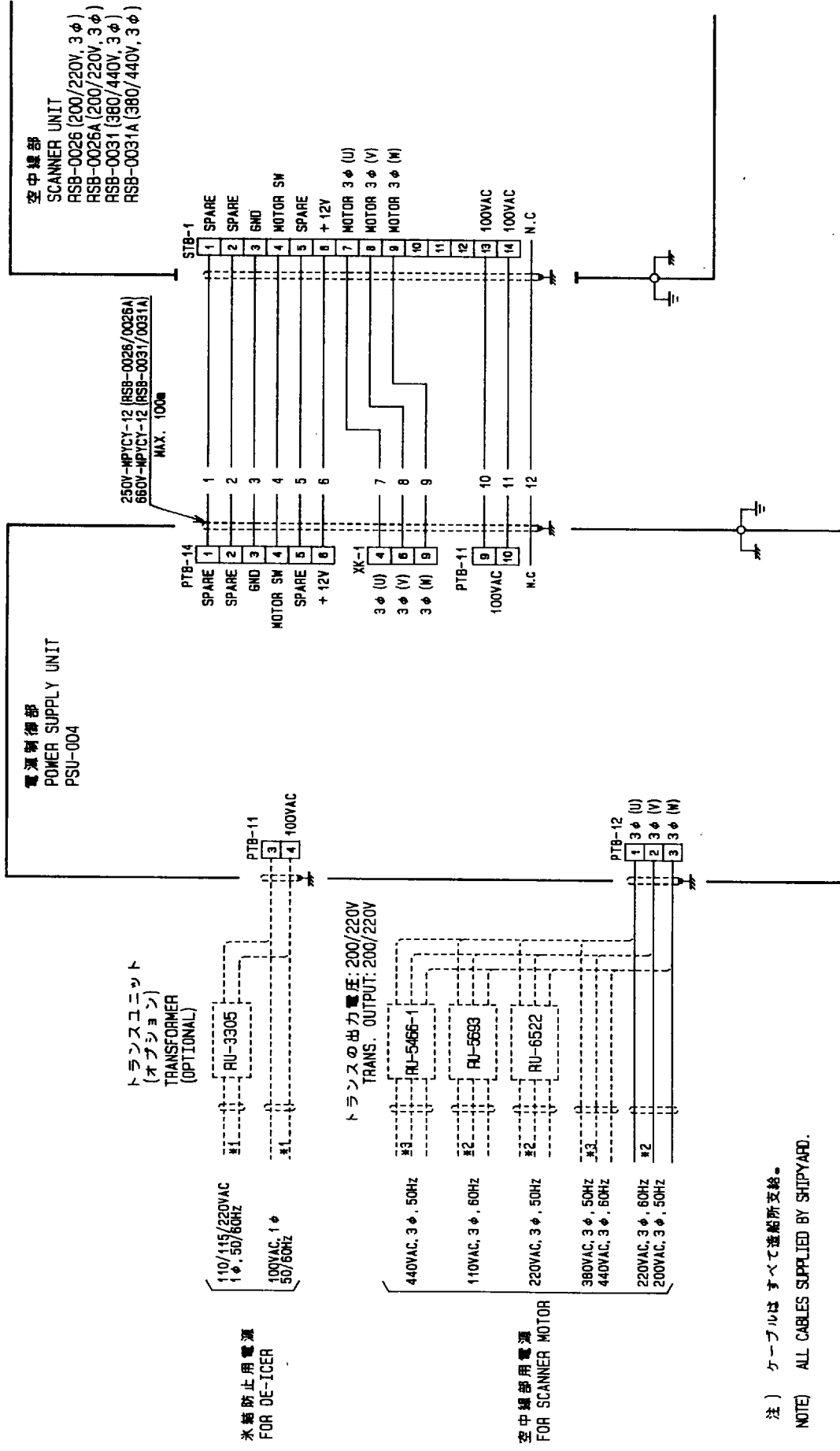

注) ケーブルはすべて造船所支給。
NOTE) ALL CABLES SUPPLIED BY SHIPYARD.

CABLE TYPE

- *1 : 250V-IPYCY-1.25 OR 250V-IPYCY-1.25
- *2 : 250V-IPYCY-3.5 OR 250V-IPYCY-3.5
- *3 : 660V-IPYCY-3.5 OR 660V-IPYCY-3.5

承認 APPROVED	May 11. 94 /KED/A	名称 TITLE	相互結線図 INTERCONNECTION (2/2)
検閲 CHECKED	May. 11. 94 MUR/MOTO	図番 DWG. NO.	C3387-C02-A
製図 DRAWN	May. 12. 94 OKADA/TIC		

FR-2130S

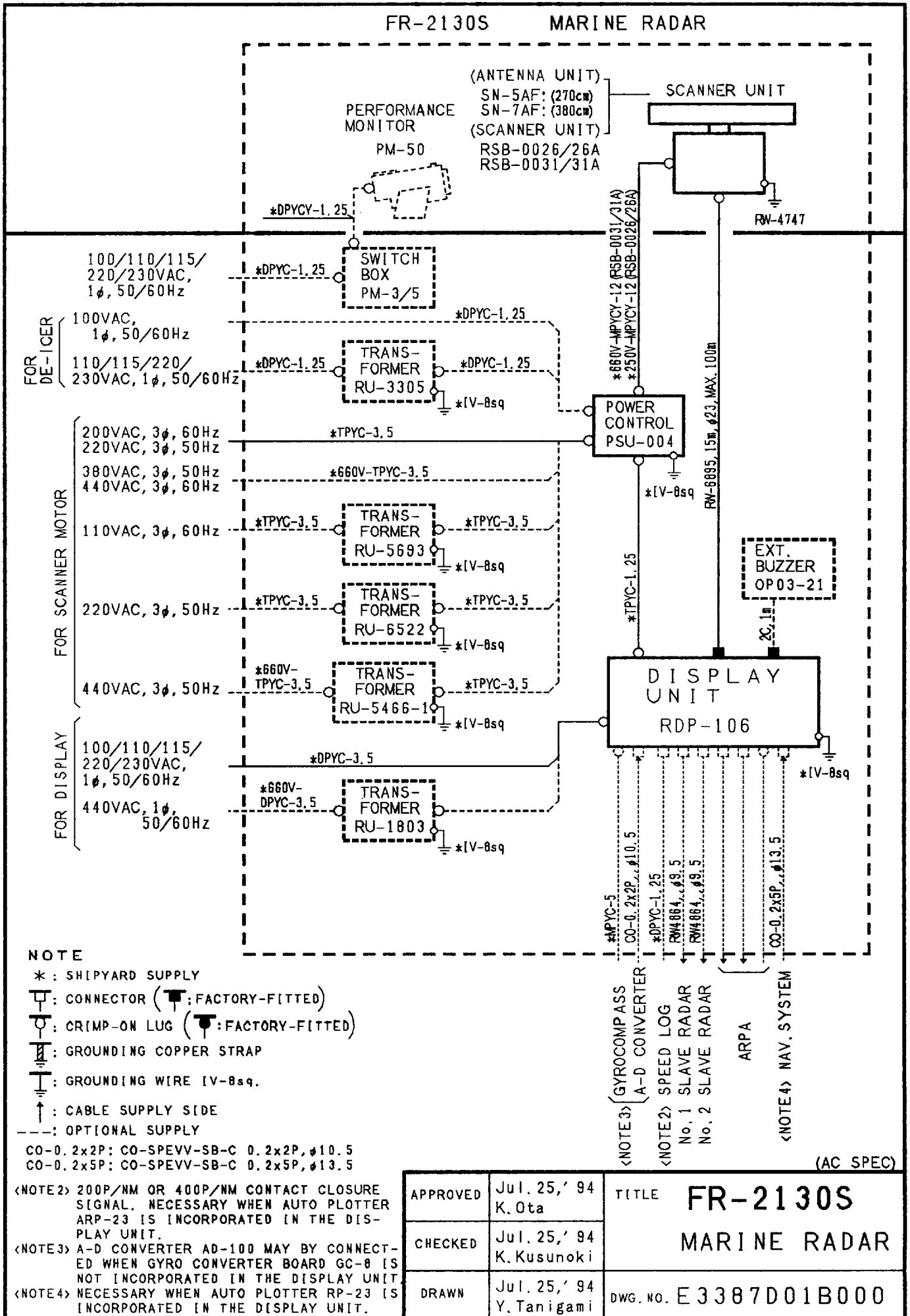

FR-2130S MARINE RADAR

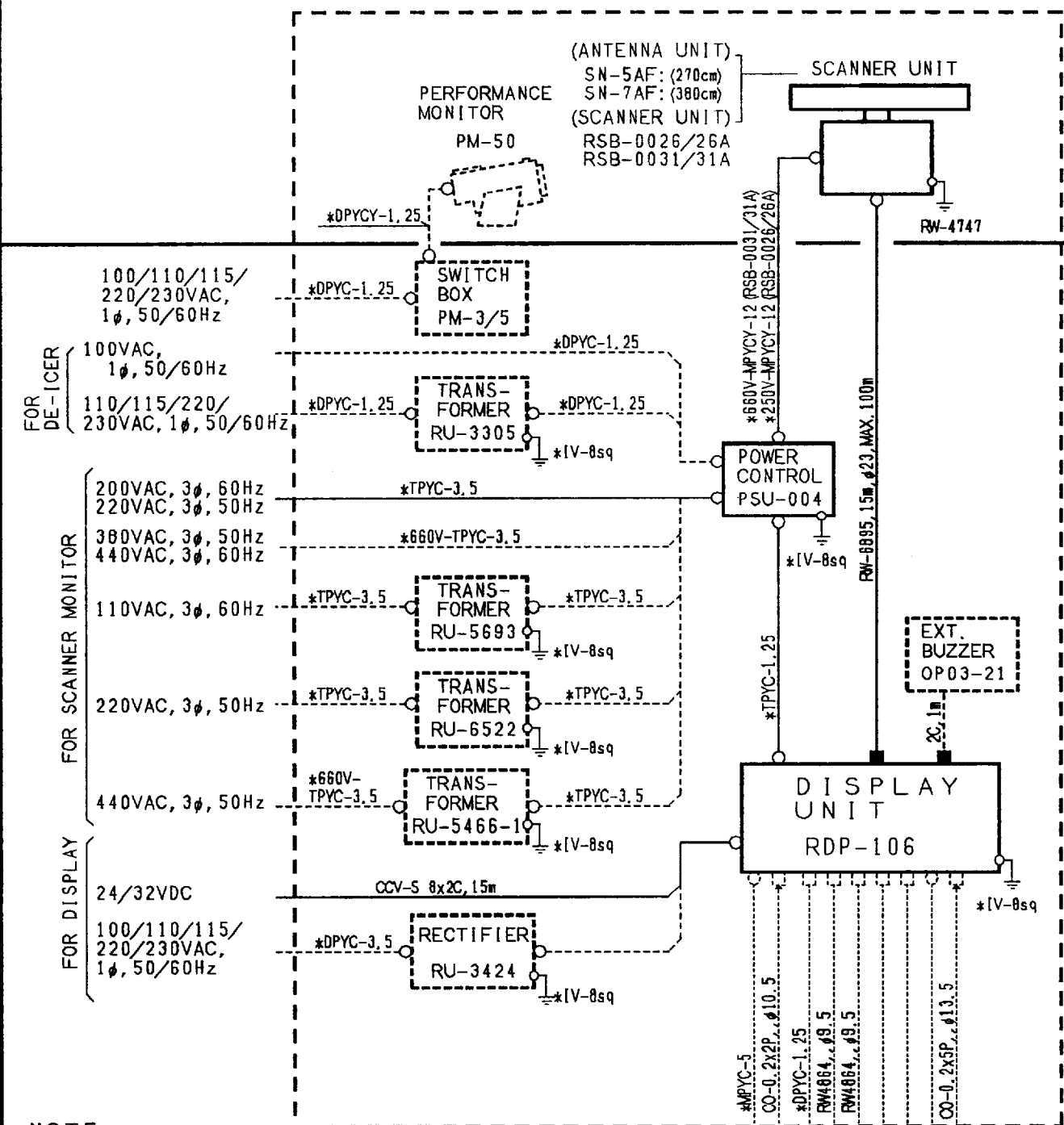

NOTE

- * : SHIPYARD SUPPLY
- ☐ : CONNECTOR (☐ : FACTORY-FITTED)
- : CRIMP-ON LUG (○ : FACTORY-FITTED)
- : GROUNDING COPPER STRAP
- : GROUNDING WIRE IV-8sq.
- ↑ : CABLE SUPPLY SIDE
- - - : OPTIONAL SUPPLY

CO-0.2x2P: CO-SPEVV-SB-C 0.2x2P, φ10.5
 CO-0.2x5P: CO-SPEVV-SB-C 0.2x5P, φ13.5

- <NOTE2> 200P/NM OR 400P/NM CONTACT CLOSURE SIGNAL. NECESSARY WHEN AUTO PLOTTER ARP-23 IS INCORPORATED IN THE DISPLAY UNIT.
- <NOTE3> A-D CONVERTER AD-100 MAY BY CONNECTED WHEN GYRO CONVERTER BOARD GC-8 IS NOT INCORPORATED IN THE DISPLAY UNIT
- <NOTE4> NECESSARY WHEN AUTO PLOTTER RP-23 IS INCORPORATED IN THE DISPLAY UNIT.

APPROVED	Jul. 25, '94 K. Ota	TITLE	FR-2130S MARINE RADAR
CHECKED	Jul. 25, '94 K. Kusunoki		
DRAWN	Jul. 25, '94 Y. Tanigami	DWG. NO.	E3387D02B000

(DC SPEC)

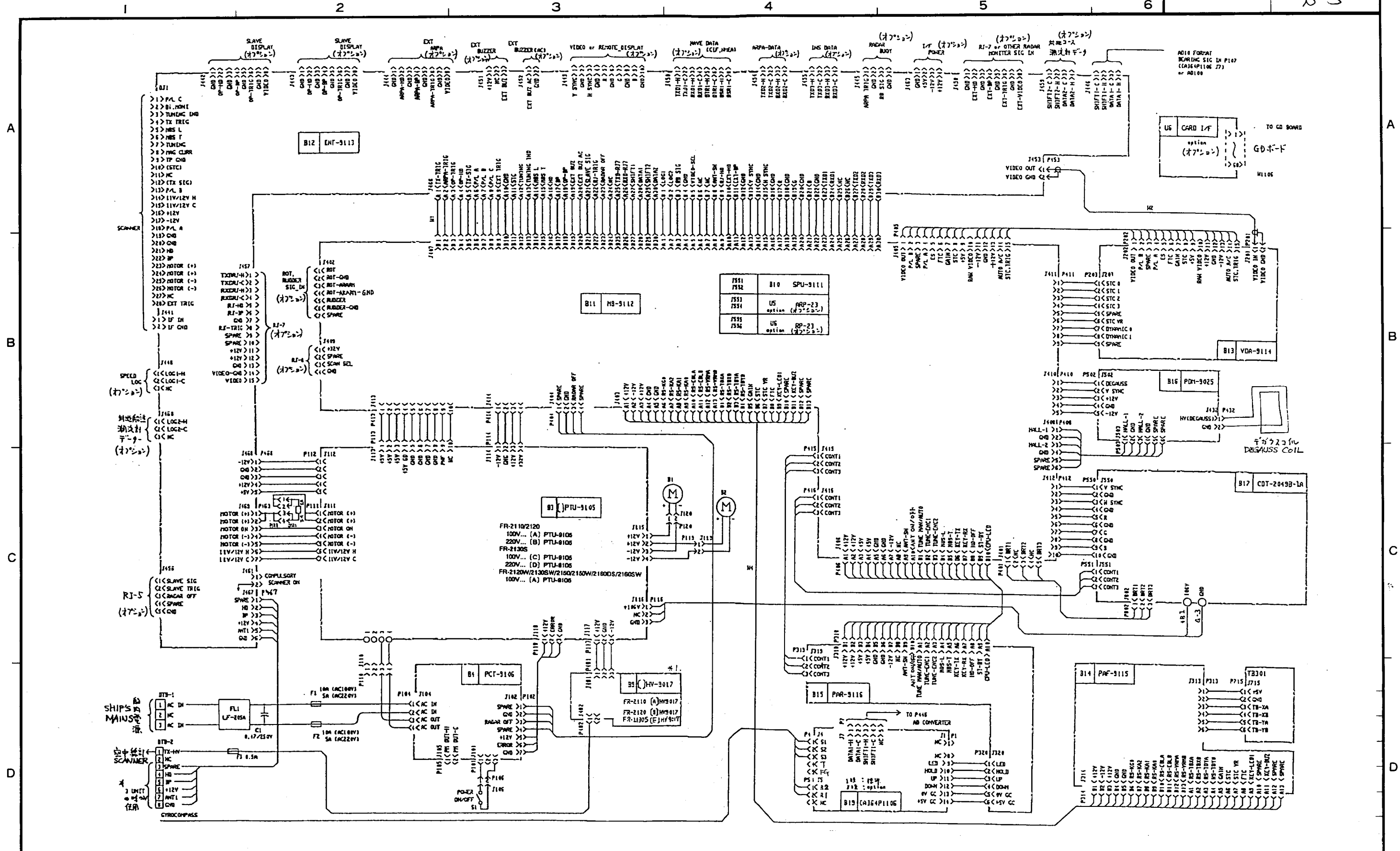

REMARKS		TYPE	
		名称	指示部総合回路図 AC仕様
DRAWN	APPROVED Nov. 25 94 K.M. IKEDA	NAME	DISPLAY UNIT AC SPEC
SCALE	MASS kg	APPLICABLE TO:	DWG NO. C3382-K01-E
		BLOCK NO.	

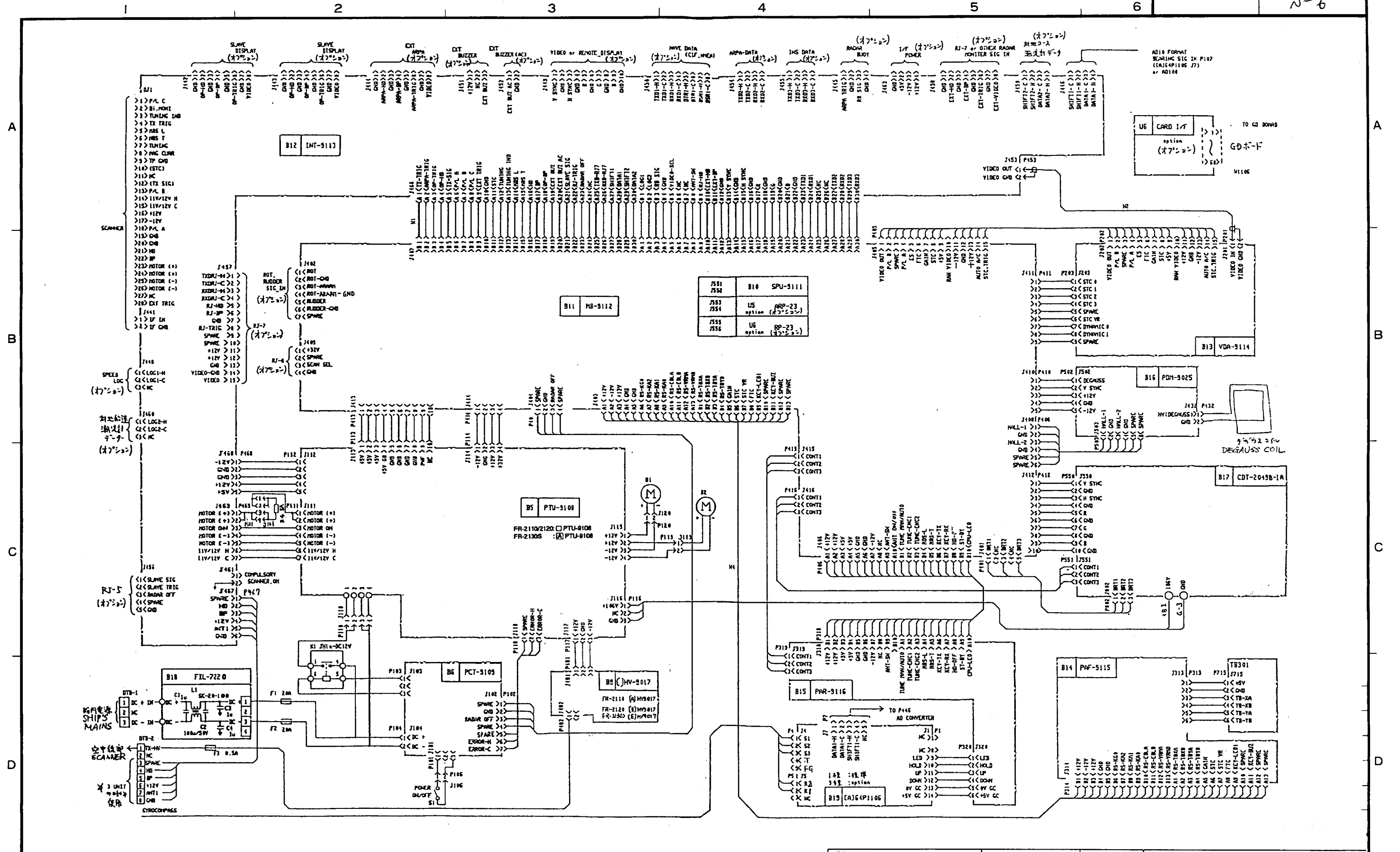

NOTE: * 1... HV-9017 PCB IS NOT PROVIDED FOR FR-2120W/2150W/2150/2130SW/2160SW/2160DS. FR-2120W/2150W/2150/2130SW/2160SW/2160DSのとき HV-9017 基板は不要。

REMARKS		TYPE	
DRAWN K. M	APPROVED Nobuhiro KEDA	FR2100SER	1B 1
SCALE	MASS kg	APPLICABLE TO: (MODEL)	BLOCK NO.
		NAME 指示部総合回路図 DC仕様 DISPLAY UNIT DC SPEC	
		DWG NO. C3382-K02-E	

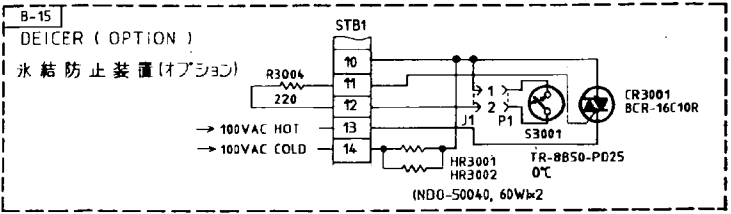
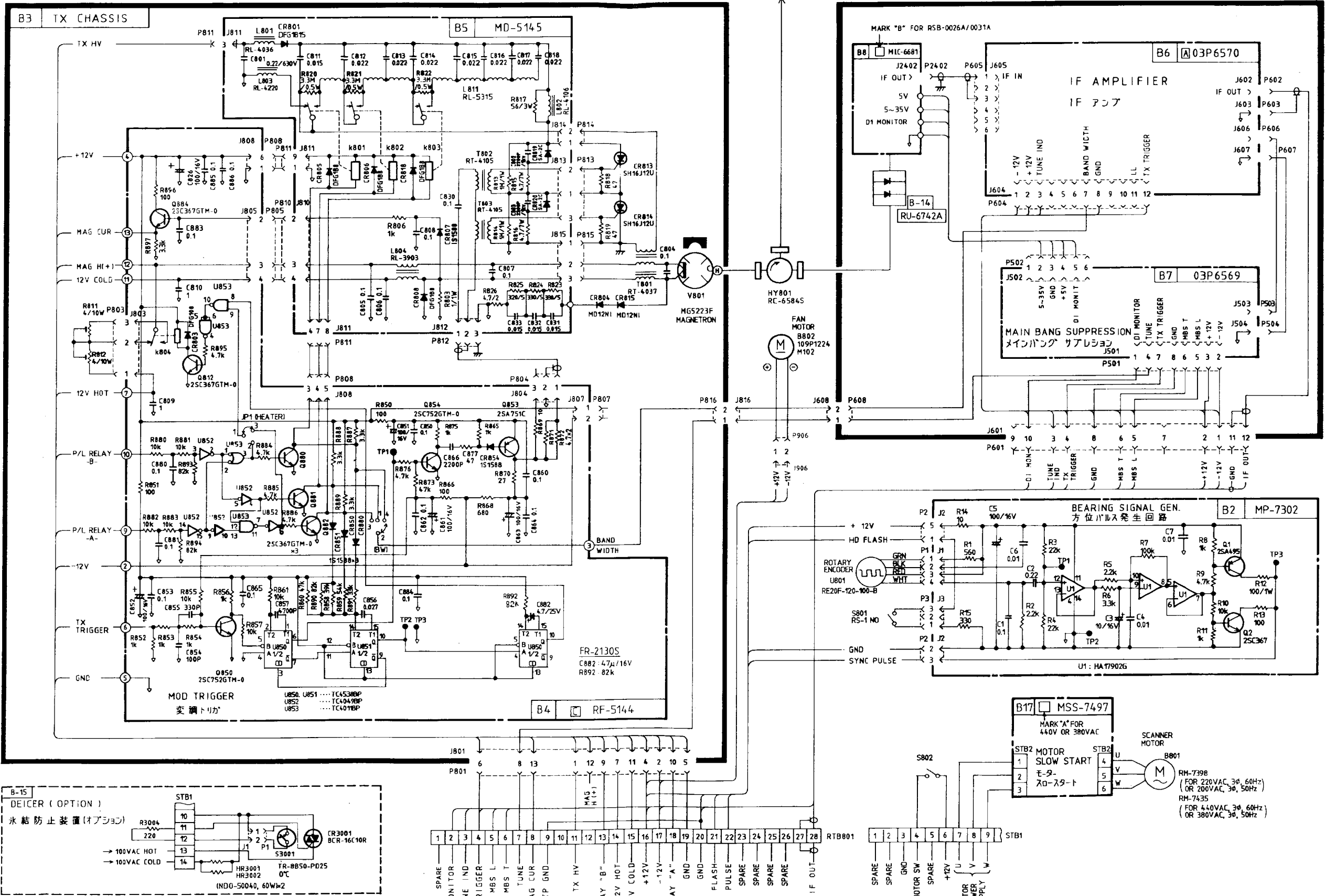

NOTE: 特記なき抵抗の単位は Ω, 1/4W またコンデンサは μF.
ALL RESISTANCE IN OHMS, 1/4W AND CAPACITANCE IN MICROFARADS UNLESS NOTED OTHERWISE.

DRAWN NOV. 1 '95 E. KISHIWA	FR2830S FR1460DS FR2030S FR2130S FR2835S FR2835S	TYPE RSB0026, 26A/RSB0031, 31A
CHECKED NOV. 1 '95 T. SAITO		名称 空中線部結合
APPROVED NOV. 1 '95 K. OTSU		回路図
SCALE MSS KR	APPLICABLE TO: (MODEL)	BLOCK NO. NAME SCANNER UNIT GENERAL
DWG. NO. C3311-010-1		SCHEMATIC DIAGRAM

電源制御部 PSU-004

船内電源
SHIP'S MAINS

指示部用
FOR DISPLAY UNIT
100/110/115VAC (HOT)
(COILB)
水精防止用
FOR DE-ICER
100VAC (HOT)
(COILB)

空中線部用
FOR SCANNER MOTOR
200/220/330/440VAC U
V
W
FOR 3 PHASE
SCANNER MOTOR

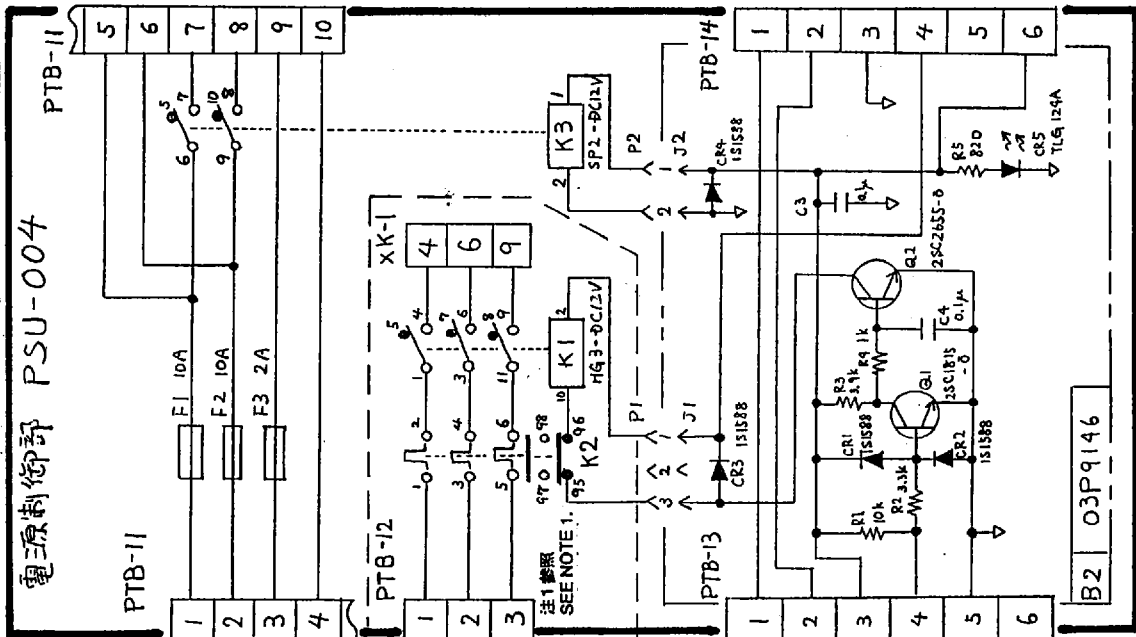

指示部へ
TO DISPLAY UNIT
送受信部
または空中線部電源部へ
TO TRANSCIVER UNIT
OR POWER SUPPLY UNIT (PSU-002)
空中線部へ
TO SCANNER UNIT

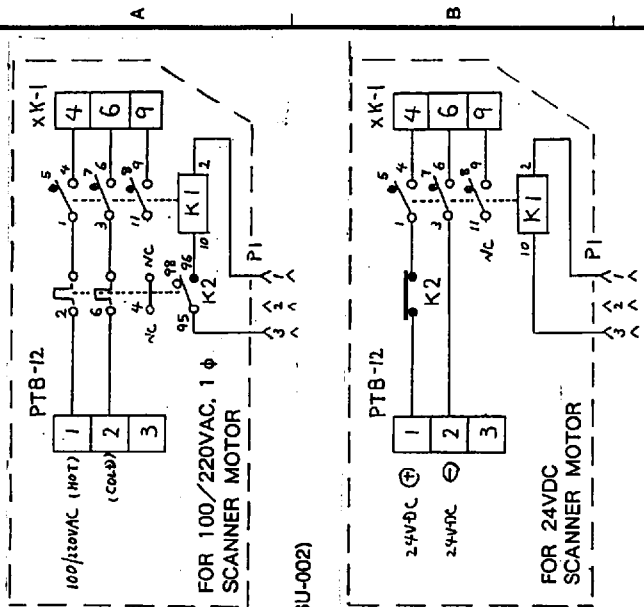

1) 注1/NOTE 1

船内電源 SHIP'S MAINS	空中線部 SCANNER UNIT	サーマルリレー THERMAL RELAY (KZ)
型式 / TYPE	型式 / TYPE	設定値 / SETTING
200/220VAC, 3φ	RSB-0026/0026A	TR-ONE/3, 1.7A 2.3A
200/220VAC, 3φ	RSB-0027	TR-ONE/3, 1.7A 2.3A
380/440VAC, 3φ	RSB-0031/0031A	TR-ONE/3, 0.8A 1.0A
380/440VAC, 3φ	RSB-0032	TR-ONE/3, 0.8A 1.0A
200/220VAC, 3φ	RSB-0041	TR-ONE/3, 0.8A 0.8A
380/440VAC, 3φ	RSB-0042	TR-ONE/3, 0.36A 0.4A
200/220VAC, 3φ	RSB-0049	TR-ONE/3, 0.8A 0.8A
100VAC, 1φ	RSB-0043	BMS9-04-8K 3.0A
220VAC, 1φ	RSB-0046	BMS9-04-8K 1.8A
24VDC	RSB-0050	BAC101505D 5A (not adjustable)
	RSB-0051	BAC101505D 5A (not adjustable)

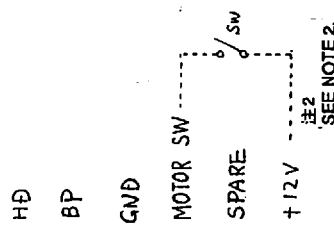

2) 注2/NOTE 2

FR-2160DSのときはPTB-14の#4と#6を現場で短絡すること
FOR FR-2160DS, PUT A JUMPER BETWEEN #4 AND #6 OF PTB-14 AT INSTALLATION.

FR-2120W
FR-2150
FR-2130S
FR-2160SW

FR/FAR-2835SW FR/FAR-2825W
FR/FAR-2865SW FR/FAR-2855W
FR/FAR-2835 FR/FAR-2855
FR/FAR-2835S FR/FAR-2835S

承認 APPROVED: 11/19/94
検閲 CHECKED: Feb. 18, 94
製図 DRAWN: Feb. 17, 94
名簿 TITLE: PSU-004
電源制御部 POWER SUPPLY UNIT
図番 DWG. NO. C3385-K01-C

5-8

Free Manuals Download Website

<http://myh66.com>

<http://usermanuals.us>

<http://www.somanuals.com>

<http://www.4manuals.cc>

<http://www.manual-lib.com>

<http://www.404manual.com>

<http://www.luxmanual.com>

<http://aubethermostatmanual.com>

Golf course search by state

<http://golfingnear.com>

Email search by domain

<http://emailbydomain.com>

Auto manuals search

<http://auto.somanuals.com>

TV manuals search

<http://tv.somanuals.com>