

# FURUNO

## OPERATOR'S MANUAL

COLOR RADAR

MODEL FCR - 1010



**FURUNO ELECTRIC CO., LTD.**  
NISHINOMIYA, JAPAN

©FURUNO ELECTRIC CO., LTD.

9-52, Ashihara-cho,  
Nishinomiya, Japan 662

Telephone: 0798-65-2111  
Telefax: 0798-65-4200

-Your Local Agent/Dealer

All rights reserved. Printed in Japan

FIRST EDITION : DEC 1990  
E : AUG. 28, 1997

(HIMA) PUB. No. OME-33510  
FCR-1010





# SAFETY INSTRUCTIONS

## Safety Instructions for the Operator



### DANGER



Do not open the equipment.

Hazardous voltage which will cause death or serious injury exists inside the equipment. Only qualified personnel should work inside the equipment.



### WARNING



Turn off the radar power switch before servicing the antenna unit. Post a warning sign near the switch indicating it should not be turned on while the antenna unit is being serviced.

Prevent the potential risk of exposure to RF radiation hazard.



Wear a safety belt and hard hat when working on the antenna unit.

Serious injury or death can result if someone falls from the radar antenna mast.



Stay away from transmitting antenna.

The radar antenna emits microwave radiation which can be harmful to the human body, particularly the eyes. Never look directly into the antenna radiator from a distance of less than 1 meter when the radar is in operation.



### WARNING

Do not disassemble or modify the equipment.

Fire, electrical shock or serious injury can result.

Turn off the power immediately if water leaks into the equipment or the equipment is emitting smoke or fire.

Continued use of the equipment can cause fire or electrical shock.

Do not place liquid-filled containers on the top of the equipment.

Fire or electrical shock can result if a liquid spills into the equipment.

Keep heater away from equipment.

Heat can alter equipment shape and cause overheating.



### CAUTION

Use the proper fuse.

Use of a wrong fuse can result in fire or permanent equipment damage.

Do not use the equipment for other than its intended purpose.

Personal injury can result if the equipment is used as a chair or stepping stool, for example.

Do not place objects on the top of the equipment.

The equipment can overheat or personal injury can result if the object falls.

# Safety Instructions for the Installer

## **DANGER**



Do not work inside the equipment unless totally familiar with electrical circuits.

Hazardous voltage which will cause death or serious injury exists inside the equipment.

## **WARNING**



Wear a safety belt and hard hat when working on the antenna unit.

Serious injury or death can result if someone falls from the radar antenna mast.



If applicable, turn off the power at the mains switchboard before beginning the installation. Post a sign near the switch to indicate it should not be turned on while the equipment is being installed.

Fire, electrical shock or serious injury can result if the power is left on or is applied while the equipment is being installed.

## **CAUTION**



Ground the equipment to prevent electrical shock and mutual interference.

Confirm that the power supply voltage is compatible with the voltage rating of the equipment.

Connection to the wrong power supply can cause fire or equipment damage. The voltage rating appears on the label at the rear of the display unit.

Use the correct fuse.

Use of a wrong fuse can cause fire or equipment damage.

### FCR-1010/1030/1040/1100 RADARS Changing Input Voltage

The above units can operate by input voltages of 24/32 VDC or 12 VDC. If not specified when ordering, the units come ready for 24/32 VDC connection. For 12 VDC ship's mains, replace a fuse in the display unit and short terminals on the POWER Board (PTU-8764) as prescribed in the circuit diagram (attached).

#### Procedure

##### 1) fuse

The amperage of the fuse (F1351) at the rear of the display unit should be;

Ship's Mains	FCR-1010/1030/1040	FCR-1100
24/32 VDC	10A	10A
12 VDC	15A	20A

Spare fuses are supplied with each unit.

##### 2) jumper wire

Process terminals as shown in NOTE 1 on the circuit diagram. Fig. 1 shows the locations of the terminals. To prevent miswiring, remove jumper wires before processing terminals. Jumper wire should be 0.52 sq (factory specification).

*NOTE: POWER Boards PTU-8764A (FCR-1100) and PTU-8764 (FCR-1010/1030/1040) are not compatible with one another.*

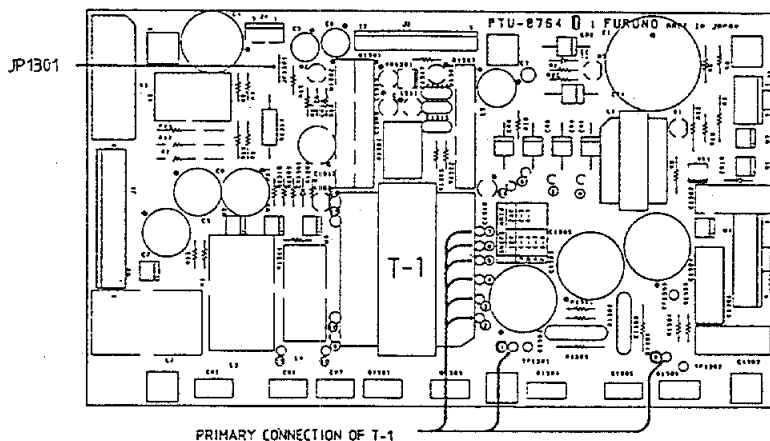

Fig. 1

**NOTE:** For **POWER SUPPLY** Board version no. **PTU-8764-11**, the pattern between **TP1301** and ① (see arrow in Fig. 2) is missing. If the input voltage is changed to **12 VDC**, please add this pattern as shown in Fig. 3. This modification is not required for **POWER SUPPLY** board version no. **22**, which will be produced from **3/91**.

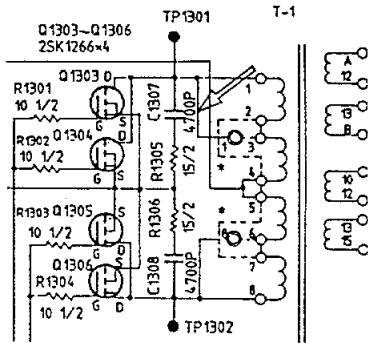

Fig. 2

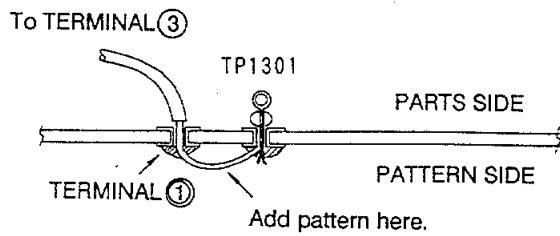

Fig. 3

---

# Table of Contents

<b>FOREWORD</b> .....	<b>v</b>
GENERAL SAFETY INFORMATION .....	vi
OPERATING PRECAUTIONS .....	vi
FEATURES .....	vii
<b>SPECIFICATIONS</b> .....	<b>ix</b>
<b>1. PRINCIPLE OF OPERATION</b> .....	<b>1-1</b>
<b>2. OPERATIONAL OVERVIEW</b> .....	<b>2-1</b>
THE FRONT PANEL .....	2-1
Description of controls .....	2-2
TURNING THE UNIT ON AND OFF .....	2-4
BASIC OPERATION .....	2-4
Range selection .....	2-5
Adjusting the GAIN control .....	2-6
Adjusting the A/C SEA control .....	2-7
Tuning the radar receiver .....	2-8
Adjusting display brightness .....	2-8
Selecting display color .....	2-8
Adjusting control panel backlighting .....	2-8
Erasing the heading mark .....	2-8
THE FUNCTION TOUCHPAD .....	2-9
MEASURING RANGE AND BEARING .....	2-10
Range .....	2-10
Bearing .....	2-11
REDUCING INTERFERENCE .....	2-13
Precipitation interference .....	2-13
Radar interference .....	2-14
ZOOM .....	2-15
MEASURING RANGE AND BEARING BETWEEN TWO TARGETS .....	2-16
GUARD ALARM .....	2-18
SHIFTING THE DISPLAY .....	2-20
PLOTTING .....	2-21
NAVIGATION DATA .....	2-22
BETTER DISTINCTION OF ECHOES .....	2-23
<b>3. APPLICATION</b> .....	<b>3-1</b>
FACTORS AFFECTING MINIMUM RANGE .....	3-1
Sea return .....	3-1
Vertical beamwidth .....	3-1
FACTORS AFFECTING MAXIMUM RANGE .....	3-2
Radar horizon .....	3-2
Target properties .....	3-3

INTERPRETING THE DISPLAY .....	3-4
Land targets .....	3-4
Ship targets .....	3-5
Echo size .....	3-5
FALSE ECHOES .....	3-6
Multiple echoes .....	3-6
Side-Lobe echoes .....	3-6
Blind and shadow sectors .....	3-7
Indirect echoes .....	3-7
RADAR PICTURE AND CORRESPONDING CHART .....	3-8
POSITION FIXING WITH RADAR .....	3-9
By radar range .....	3-9
By range and bearing to a point of land .....	3-9
By two bearings .....	3-10
COLLISION AVOIDANCE AND RELATIVE MOTION .....	3-11
Assessing the risk .....	3-12
<b>4. MAINTENANCE .....</b>	<b>4-1</b>
GENERAL .....	4-1
SCANNER UNIT .....	4-1
Radiator .....	4-1
DISPLAY UNIT .....	4-2
Cleaning the display screen .....	4-2
Fuse replacement .....	4-2
<b>5. TROUBLESHOOTING .....</b>	<b>5-1</b>
BASIC TROUBLESHOOTING .....	5-2
ADVANCED TROUBLESHOOTING .....	5-3
Typical problems and their causes .....	5-3
CHECKING THE MAGNETRON .....	5-4
<b>6. INSTALLATION .....</b>	<b>6-1</b>
GENERAL MOUNTING CONSIDERATIONS .....	6-1
SCANNER UNIT INSTALLATION .....	6-2
Siting considerations .....	6-2
Mounting .....	6-3
Wiring and final preparation of scanner unit .....	6-7
DISPLAY UNIT INSTALLATION .....	6-9
Antenna connection .....	6-10
Power connection .....	6-11
Ground connection .....	6-12
Gyrocompass (or heading sensor) connection (option) .....	6-12
External navigational receiver connection (option) .....	6-12
CHECKING THE INSTALLATION .....	6-13
ADJUSTMENTS .....	6-14
Initial procedures .....	6-14
Sweep timing .....	6-14
Auto tuning .....	6-15
Relative bearing alignment .....	6-17
Preset gain .....	6-19
Magnetron heater voltage .....	6-20
MEASUREMENT OF BLIND SHADOW SECTORS .....	6-21



---

CIRCUIT DIAGRAMS .....	S-1
Interconnection Diagram .....	S-1
Display Unit .....	S-2
POWER SUPPLY Board .....	S-3
Scanner Unit .....	S-4
OUTLINE DRAWINGS .....	D-1
Display Unit .....	D-1
Scanner Unit .....	D-2

**This page intentionally left blank.**

---

# FOREWORD

Congratulations on your choice of the FURUNO FCR-1010 Color Radar. We are confident you will see why the FURUNO name has become synonymous with quality and reliability.

For over 40 years FURUNO Electric Company has enjoyed an enviable reputation for quality and reliability throughout the world. This dedication to excellence is furthered by our extensive global network of agents and dealers.

The FCR-1010 is just one of many Furuno developments in the field of radar. It is compact and light-weight and while it is suitable for use on a wide variety of vessels, you should consult with your Furuno dealer to determine whether it is suitable for use on a particular vessel. Your Furuno dealer can also advise you as to other Furuno radar units which you can purchase, depending on your particular needs and expected uses of the equipment.

This unit is designed and constructed to give the user many years of trouble-free operation. However, please do not attempt to install, operate or conduct any maintenance before carefully reading and following the recommended procedures set forth in this manual.

While this unit is generally easy to install by following the enclosed installation directions, any purchaser who has doubts about his or her technical abilities may wish to have this unit installed by a Furuno representative or other qualified technician. This unit can perform its intended functions only when properly installed (and maintained).

We would appreciate feedback from you, the end-user, about whether we are achieving our purposes.

Thank you for considering and purchasing Furuno equipment.

---

## General Safety Information

---

Be sure to read all the safety information which follows before attempting to install, operate or maintain your radar.

"DANGER," "WARNING," and "CAUTION" notices appear throughout this manual. It is the responsibility of the user of this equipment to read, understand and follow these notices. If you have any questions regarding these safety instructions, please contact a Furuno agent or dealer.

---

## Operating Precautions

---

- Navigation is a complex and detailed skill which requires knowledge, judgment and experience to perform effectively. Errors in navigation can lead to catastrophic injury or even death in some circumstances. Navigational errors can cause collisions between vessels, collisions with land and land-based structures, and can lead to being lost at sea.

Although this manual explains much about the operation of the radar and how it can aid in the navigation of your vessel, it is not a substitute for practical experience, seamanship or formal training. It is, therefore, recommended that you work to develop this skill by enrolling in a course in navigation taught by a qualified maritime school.

- No single navigational aid (including this radar) should ever be relied upon as the exclusive method for navigating your vessel. The navigator is responsible for checking all aids available to confirm his position. Electronic aids are meant to assist the navigator, not replace him.
- The 1972 Convention on the International Regulations for Preventing Collisions at Sea (1972 COLREGS) provide statutory requirements for the operation of any vessel including the posting of lookouts. The operator of the vessel is responsible for compliance with these requirements whether or not a radar is in use.

---

## Features

---

Your unit has a large variety of functions, all contained in a remarkably small cabinet.

- All controls respond immediately to the operator's command and each time a touchpad is depressed, the corresponding change can be seen on the screen.
- Daylight viewing radar especially designed for small craft and sailing yachts.
- Traditional FURUNO reliability and quality in a compact, lightweight and low-cost color radar.
- High definition 10" raster-scan color display.
- 3 colors or 8 levels of target quantization for high target definition without problems associated with single-level quantization systems.
- Automatic tuning for easy operation.
- On-screen alpha-numeric readout of all operational information.
- Near maintenance-free design enhances reliability.
- 8 ranges from 0.25 to 24 nautical miles.
- 3 pulselengths and pulse repetition rates automatically selected, for optimum short-range to long-range performance.
- Field-proven, heavy duty gearbox and attractive 54 cm center-fed radome capable of withstanding 100-knot wind velocity.
- Two EBLs (Electronic Bearing Line), two VRMs (Variable Range Marker), Guard Alarm, Offset EBL and Cursor controlled by a trackball.
- Guard zone alarm and offset EBL provided as standard features.
- Operates on 12, 24 or 32 VDC power supply and consumes only 65 W. Protection against reverse polarity and excessive voltage provided.
- Ship's position in latitude/longitude (or Loran C time differences (TDs)), ship's speed, and range/bearing to a waypoint optionally shown in the bottom text area. (External navigator which can output such data in CIF or NMEA0183 format required.)

**This page intentionally left blank.**

# SPECIFICATIONS

## SCANNER UNIT

- |                         |   |
|-------------------------|---|
| 1. Radiator             | Slotted Waveguide Array (housed in radome)  |
| 2. Radiator Length      | 54 cm   |
| 3. Horizontal Beamwidth | within 4.0°   |
| 4. Vertical Beamwidth   | 25°   |
| 5. Sidelobe Attenuation | Within $\pm 20^\circ$ of mainlobe: -18 dB or less<br>Outside $\pm 20^\circ$ of mainlobe: -23 dB or less |
| 6. Polarization         | Horizontal  |
| 7. Antenna Rotation     | 24 rpm nominal  |

## TRANSCIVER MODULE (contained in radome)

- |  |                            |
|--|----------------------------|
| 1. Transmitting Tube                   | Magnetron 9M302/E3513      |
| 2. Frequency & Modulation              | 9410 MHz $\pm 30$ MHz, PON |
| 3. Peak Output Power                   | 3 kW nominal               |
| 4. Pulselength & Pulse Repetition Rate |                            |

Item/Range (nm)	0.25	0.5	0.75	1.5	3	6	12	24
Pulse Repetition Rate	Approx. 2100 Hz			Approx. 1200 Hz		Approx. 600 Hz		
Pulselength	0.08 $\mu$ s (short)			0.3 $\mu$ s (middle)		0.8 $\mu$ s (long)		

- |                           |   |
|---------------------------|---|
| 5. Modulator              | FET Switching Method                              |
| 6. Intermediate Frequency | 60 MHz  |
| 7. Tuning                 | Automatic (manual possible)                       |
| 8. Receiver Front End     | MIC (Microwave IC)                                |
| 9. Bandwidth              | 7 MHz (short/middle pulses)<br>3 MHz (long pulse) |
| 10. Duplexer              | Circulator with diode limiter                     |
| 11. Noise Figure          | 9 dB nominal (standard)                           |

## DISPLAY UNIT

- |                      |  |
|----------------------|--|
| 1. Indication System | Daylight bright raster scan color PPI display  |
| 2. Picture Tube      | 10 inch color CRT (142 mm $\times$ 190 mm: effective)  |
| 3. Echo Color        | Target echoes displayed according to strength, in one of three ways: in three colors (red, yellow, green), or in eight levels of yellow or green |

4. Range (nm)	
5. Range Ring Interval (nm)	
6. Number of Rings	
7. Bearing Resolution	Within 4.6°
8. Range Resolution	Better than 45.8 m
9. Bearing Accuracy	Better than 1°
10. Minimum Range	Better than 27.2 m
11. Range Ring Accuracy	0.9% or 5 m, whichever is the greater
12. VRM Accuracy	0.9% or 5 m, whichever is the greater
13. Mark Indication	Heading Mark, Bearing Scale, Range Ring, VRM, EBL, Tuning Bar, Alarm Zone, Cursor, Function Indication, Waypoint (Option)
14. Numeral/Character Indication	Range, Range Ring Interval, EBL, VRM, Interference Rejection (IR), ST-BY, Range and Bearing to Cursor (I), Rain Clutter Rejection (FTC1-FTC3), Plotting Interval and Elapsed Time (PLOT), Echo Stretch (ES), Radar Alarm (GUARD), Zoom (ZOOM), Tuning (AUTO or MAN.), Latitude/Longitude (LL, Option), Ship's Speed (SPD, Option), Range and bearing to Waypoint (WP, Option), MAG or GYRO (Option)
15. Interference Rejector	Built-in
16. External Sig. In/Out Terminals	NMEA 0183 terminal (In) Compass Signal terminal (In) External Buzzer terminal (Out) Monitor terminal (Out)

0.25	0.5	0.75	1.5	3	6	12	24
0.05	0.1	0.25	0.25	0.5	1	2	4
5	5	3	6	6	6	6	6

**ENVIRONMENT CONDITION**

1. Vibration	
2. Ambient Temperature	Scanner Unit: -25°C to +70°C Display Unit: -15°C to +55°C
3. Humidity	Relative humidity 95% or less at +40°C

Vibration Frequency	Total Amplitude
1 to 12.5 Hz	±1.6 mm
12.5 to 25 Hz	±0.38 mm
25 to 50 Hz	±0.10 mm

**POWER SUPPLY & POWER CONSUMPTION**

12 VDC (10.2 to 20.3 V), 65 W or 24/32 VDC (20.4 to 40.0 V), 65 W  
100/110/220/230 VAC, 50/60 Hz, 1ø (rectifier required)



**COLOR**

1. Scanner Unit

Upper: N9.5  
Lower: 2.5PB 3.5/10

2. Display Unit

Cabinet: 2.5GY5/1.5  
Panel: N3.0**COMPASS SAFE DISTANCE**

Unit	Standard Compass	Steering Compass
Display Unit	0.87 m	0.65 m
Scanner Unit	3.1 m	1.75 m

**EQUIPMENT LIST**Complete Set

No.	Name	Type	Code No.	Qty	Remarks
1	Scanner Unit	RSB-0034	000-083-691	1	8 kg
2	Display Unit	RDP-088	000-084-689	1	10 kg for 12 VDC
			000-084-693		for 24/32 VDC
3	Installation Materials	CP03-10800	000-084-711	1 set	10 m sig. cable
		CP03-10810	000-084-712		15 m sig. cable
		CP03-10820	000-084-713		20 m sig. cable
		CP03-10830	000-084-714		30 m sig. cable
4	Accessories	FP03-04300	000-084-715	1 set	
5	Spare Parts	SP03-08500	000-084-710	1 set	

Installation Materials

No.	Name	Type	Code No.	Qty	Remarks
1	Connector	NJC-203-PF	000-506-703	1	for power cable
2	Signal Cable Assembly	S03-21-10 (10 m)	008-239-050	1 set	Select one. Connectors fitted.
		S03-21-15 (15 m)	008-239-060		
		S03-21-20 (20 m)	008-239-070		
		S03-21-30 (30 m)	008-239-080		
3	Crimp-on Lug	FV2-4 (blue)	000-538-118	4	for rectifier
4	Hex Bolt	M10x25 SUS304	000-862-308	4	for scanner unit mounting
5	Spring Washer	M10 SUS304	000-864-261	4	
6	Flat Washer	M10 SUS304	000-864-131	4	

Accessories

No.	Name	Type	Code No.	Qty	Remarks
1	Hood Assembly	FP03-03120	008-239-110	1	for display unit
2	Cosmetic Cap	FP03-04310	008-411-810	2	

Spare Parts

No.	Name	Type	Code No.	Qty	Remarks
1	Fuse	FGBO 15A 125 VAC	000-549-014	2	12 VDC
2	Fuse	FGBO 10A 125 VAC	000-549-065	2	24/32 VDC
3	Spare Parts Box	for F710	000-831-610	1	

Option

No.	Name	Type	Code No.	Qty	Remarks
1	NMEA Cable	22S0021-3 (5 m)	000-109-517	1	w/connector
		03S9202 (5m)	000-132-244		w/connectors
		03S9226 (10m)	000-132-336		
2	Cable Assy	22S0269-0 (10 m)	000-125-236	1	for AD converter, w/connector
3	External Buzzer	OP03-21	000-030-097	1	w/connector
4	Two-core Cable	VV-S 2.0x2C (5m)	000-104-818	1	power cable
5	Rectifier	RU-3423	000-030-443	1	for AC mains
6	X-band MIC	RU-8014	000-115-556	1	built in RF amp.
7	Mounting Bracket (1)	OP03-92	008-445-070	1	for sailboat
8	Hood w/Lenz	OP03-90	008-445-050	1	for display unit

---

# 1. PRINCIPLE OF OPERATION

The term "RADAR" is an acronym meaning RAdio Detection And Ranging. Although the basic principles of radar were developed during World War II, primarily by scientists in Great Britain and the United States, the use of echoes as an aid to navigation is not a new development.

Before the invention of radar, when running in fog near a rugged shoreline, ships would sound a short blast on their whistles, fire a shot, or strike a bell. The time between the origination of the sound and the returning of the echo indicated how far the ship was from the cliffs or the shore. The direction from which the echo was heard indicated the relative bearing of the shore.

Today, the method of determining the distance to a target is much more accurate because of pulse-modulated radar. Pulse-modulated radar determines the distance to the target by calculating the time difference between the transmission of a radar signal and the reception of the reflected echo. It is a known fact that radar waves travel at a nearly constant speed of 162,000 nautical miles per second. Therefore the time required for a transmitted signal to travel to the target and return as an echo to the source is a measure of the distance to the target. Note that the echo makes a complete round trip, but only half the time of travel is needed to determine the one-way distance to the target. This radar automatically takes this into account in making the range calculation.

The bearing to a target found by the radar is determined by the direction in which the radar scanner antenna is pointing when it emits an electronic pulse and then receives a returning echo. Each time the scanner rotates pulses are transmitted in the full 360 degree circle, each pulse at a slightly different bearing from the previous one. Therefore, if one knows the direction in which the signal is sent out, one knows the direction from which the echo must return.

Note that the speed of the radar waves out to the target and back again as echoes is extremely fast compared to the speed of rotation of the antenna. By the time radar echoes have returned to the scanner, the amount of scanner rotation after initial transmission of the radar pulse is extremely small.

The range and bearing of a target is displayed on what is called a Plan Position Indicator (PPI). This display is essentially a polar diagram, with the transmitting ship's position at the center. Images of target echoes (sometimes called a "pip") are received and displayed at their relative bearings, and at their distance from the PPI center.

With a continuous display of the images of targets, the motion of the transmitting ship is also displayed.

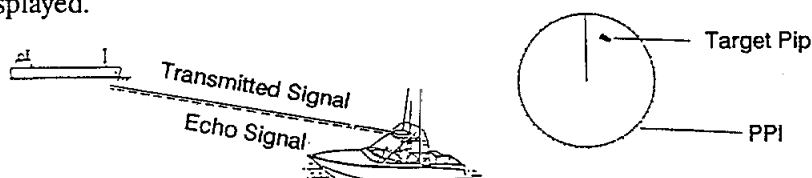

Figure 1-1 How Radar Works

This page intentionally left blank.

---

# OPERATIONAL OVERVIEW

## CAUTION

*To prevent possible bodily injury from Radio Frequency (RF) radiation hazards and scanner rotation, always make sure that no person is near the scanner unit before turning on the radar.*

---

## The Front Panel

---

The functional and user-friendly layout of the control panel makes this radar easy and instinctive to use. If you change a control setting you will see the associated reaction almost immediately on the screen. Most touchpads carry abbreviated names to show their functions and the same name appears on the screen for confirmation. (An illustration showing the location and meaning of on-screen indications appears on page 2-3.)

Examine the display unit. All controls are on the right-hand side, and the display is on the left-hand side.

The **A/C RAIN**, **A/C SEA**, and **GAIN** controls adjust the radar receiver. These controls can be locked to prevent unintentional alteration of settings. Simply push in the control until you hear a click. When readjustment is necessary, push in and release the control to bring it out again.

Moving to the large group of controls in the center of the panel, the **POWER/OFF** and **TX/OFF** touchpads turn on and off power and transmission. The **RANGE +/-** touchpads select range.

The **HM OFF**, **RING**, **FTC**, **IR** and **ECHO STRETCH** touchpads mostly turn on and off their respective function.

The **COLOR** touchpad selects the color of target echoes, background and plot echoes. And the **GUARD** touchpad turns on and off the radar guard zone alarm.

The **FUNCTION** touchpad alternately enables the functions of dual function touchpads. Each time the touchpad is pressed the function indication shifts up or down to show which function is currently available for use.

The **SHIFT/NAV**, **ZOOM/BRILL**, **PLOT/DIM**, **EBL 1/2 OFF**, **OFFSET T/R**, and **VRM 1/2 OFF** are the dual function touchpads.

The trackball, whose motion is followed by an on-screen cross hair cursor (hereafter called cursor), sets the guard zone, measures a target's range and bearing, and more.

To familiarize yourself with the controls of your unit, turn it on (presuming that it is installed) and try operating some of the controls as you review this section.

To familiarize yourself with the controls of your unit, turn it on (presuming that it is installed) and try operating some of the controls as you review this section.

## Description of controls

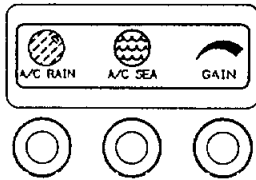

**A/C RAIN**

Suppresses rain clutter.

**A/C SEA**

Suppresses sea clutter caused by waves.

**GAIN**

Adjusts receiver sensitivity.

**POWER/OFF**

Turns on the system. Press this touchpad and TX/OFF simultaneously to turn off the system.

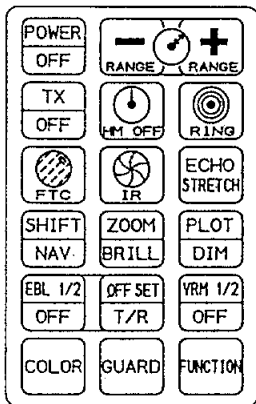

**RANGE**

Selects radar range. The "+" and "-" touchpads select a higher and lower range, respectively.

**TX/OFF**

Sets the radar to transmit or stand-by.

**HM OFF**

Temporarily erases the heading mark.

**RING**

Turns the fixed range rings on and off.

**FTC**

Suppresses heavy precipitation clutter.

**IR**

Reduces or eliminates radar interference.

**ECHO STRETCH**

Activates and releases the echo stretch function, which stretches echoes lengthwise for better distinction.

**SHIFT/NAV**

Shifts the display and turns the navigation data display (navigation input required) on and off.

**ZOOM/BRILL**

Turns the zoom function on and off and adjusts the brightness of the screen.

**PLOT/DIM**

Turns on and off the radar target plotting device and adjusts the backlighting of the control panel.

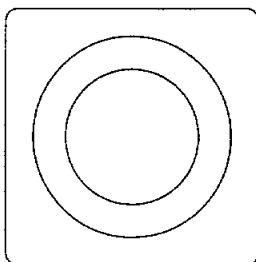

**EBL 1/2 OFF**

Turns the Electronic Bearing Lines (EBLs) on and off.

**OFFSET T/R**

Enables and disables the offset EBL and alternately selects true and relative bearing readout.

**VRM 1/2 OFF**

Turns the Variable Range Markers (VRMs) on and off.

**COLOR**

Selects color of target echoes, background and plot.

**GUARD**

Turns on and off the guard zone alarm.

**FUNCTION**

Alternately enables the functions of dual function touchpads.

**Trackball**

Controls the cursor, VRMs, EBLs, etc.

Figure 2-1 Description of Front Panel Controls

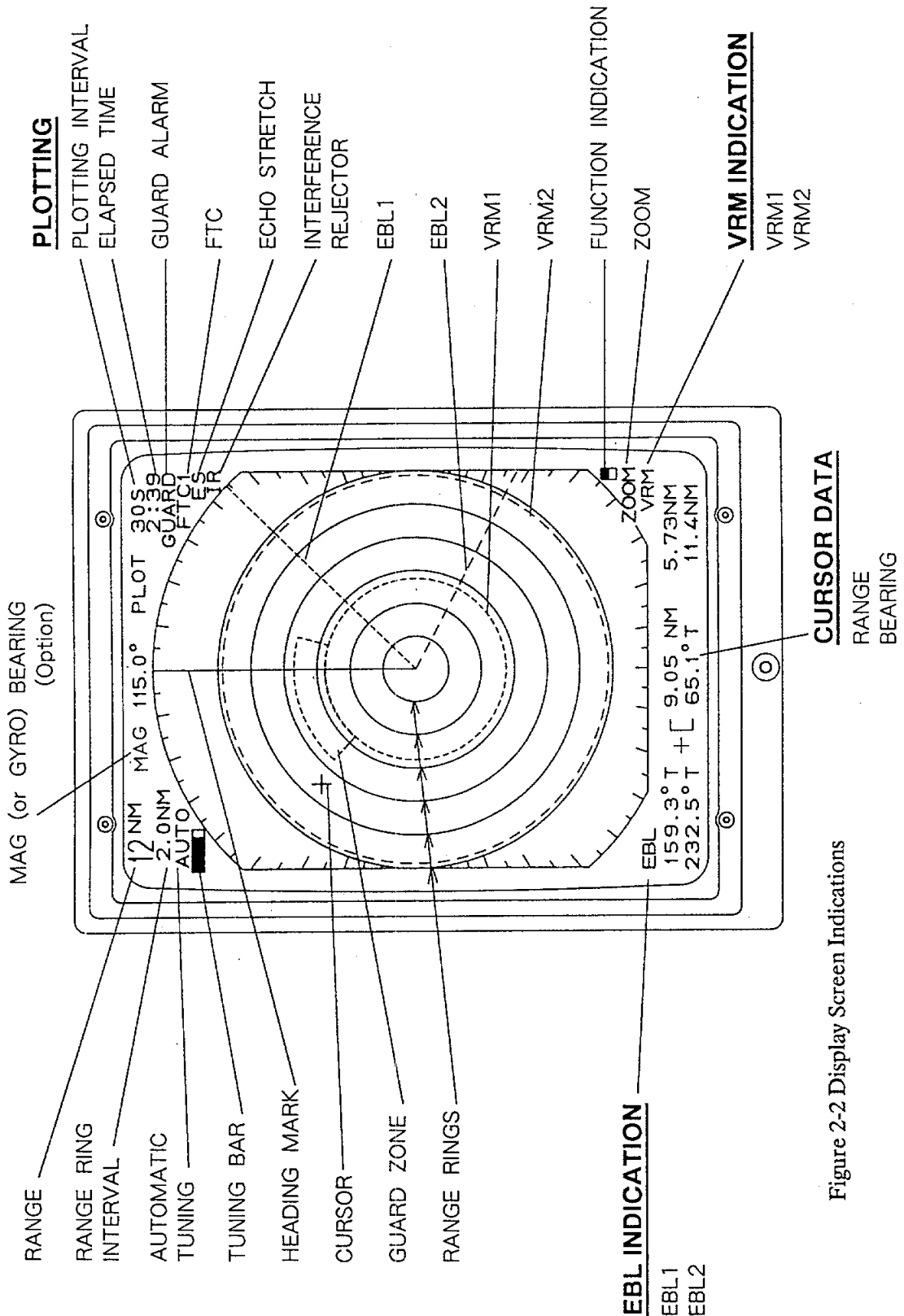

Figure 2-2 Display Screen Indications

## Turning the Unit On and Off

After confirming there are no crew near the scanner unit, press the **POWER/OFF** touchpad to turn on the power.

The front panel will light up. The magnetron takes about two minutes and thirty seconds to warm up before the radar can be operated. The time remaining for warm up of the magnetron appears at the center of the display, counting down from 2:29 to 0:01. In addition the program version number appears.

*NOTE: The VR compartment at the top right-hand corner of the display contains the controls for adjustment of gain and tuning, and suspension of scanner rotation. These controls are for use by service technicians. Please do not operate them.*

To turn off the radar, press the **POWER/OFF** and **TX/OFF** touchpads together.

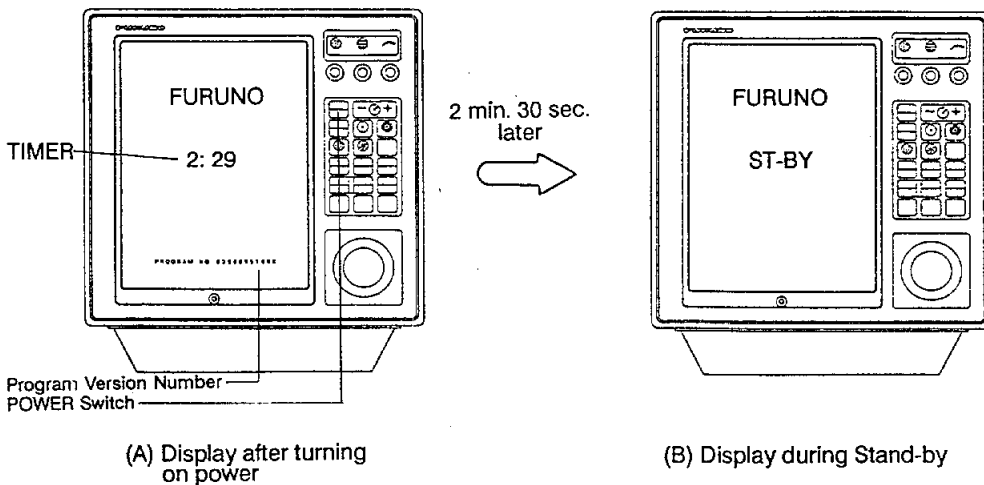

Figure 2-3 Display Unit

## Basic Operation

After the power is turned on and the magnetron has warmed up, the message "ST-BY" (Stand-By) appears at the center of the display, showing the radar is ready to transmit. However, no targets will appear on the screen until the radar is transmitting by pressing the **TX/OFF** touchpad (TX is short for "transmit"). In stand-by the radar is available for use at anytime — but no radar waves are being transmitted.

Press the **TX/OFF** touchpad to begin transmission and to rotate the radiator. The display will light up, and the status of the indications on the display will automatically be the following: **RANGE**, 3 nautical mile; **IR**, ON, and all other indications, OFF. In addition, the heading mark, the cursor, the range and bearing from own ship to the cursor intersection and the tuning bar appear. (Own ship's heading also appears if a gyrocompass is connected.) When the radar is transmitting, any echoes from targets appear on the display.



If this is your first radar, you may want to take a closer look at the display. The outermost frame on the screen (marked in degrees) is the bearing scale. The solid radial line at 0 degrees is the heading mark. The heading mark is always on the screen and shows own ship's heading.

The nearly invisible line rotating radially around the screen is the "sweep." This lets the operator know that the radar is functioning properly. The sweep rotates synchronously with the scanner, so at any given time the direction in which the scanner is pointing is known. With every rotation echoes appear on the sweep as brighter spots of light, thus presenting a complete picture of the surrounding area.

Placing the radar in stand-by helps extend component life. Therefore, when you won't be using the radar for an extended period of time, but you want to keep it in a state of readiness, set it to "ST-BY" mode by pressing the TX/OFF touchpad.

## Range selection

The range selected automatically determines the fixed range ring interval, the number of fixed range rings, pulselength, and pulse repetition rate, for optimal detection in both short and long ranges. Many ranges are either half or twice their neighbor for easy identification of targets when changing the range. The range and ring interval appear at the top left corner of the display.

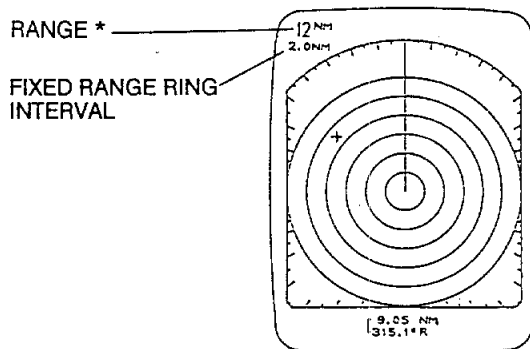

\*: This distance is from the own ship's position to the outermost position of 90° or 270°

Figure 2-4 Location of Range and Fixed Range Ring Indications

To select a range, press the plus or minus sign on the **RANGE** touchpad. Note that it is possible to increase or decrease the range setting automatically by holding down these touchpads.

### Tips on selecting range

- 1) When navigating in or around crowded harbors, select a range between 0.5 and 1.5 nautical mile to watch for possible collision situations.
- 2) If you select a lower range while on open water, increase the range occasionally to watch for vessels that may be heading your way. Remember that the maximum range a radar can see is dependent on many factors. For further details about maximum range, see the **APPLICATION** section.

## Adjusting the GAIN control

The **GAIN** control adjusts the sensitivity of the receiver, and thus the strength of echoes as they appear on the screen. Adjust it so the speckled noise background is just visible on the display.

To become acquainted with the way the control works, try rotating it between its fully counterclockwise and clockwise position as you observe the display. As you slowly turn the control clockwise you should be able to see the speckled background appear when the position of the control is between 2 and 3 o'clock.

To properly set the gain, use one of the two highest ranges (12 or 24 mile)—the speckled noise background is clearer on these ranges. If you set up for too little gain, weak echoes may be missed. If you turn the control too far clockwise, yielding too much speckled noise background, strong targets may be missed because of the poor contrast between desired echoes and the background noise on the display. Figure 2-5 illustrates examples of gain settings which are too high, proper, and too low.

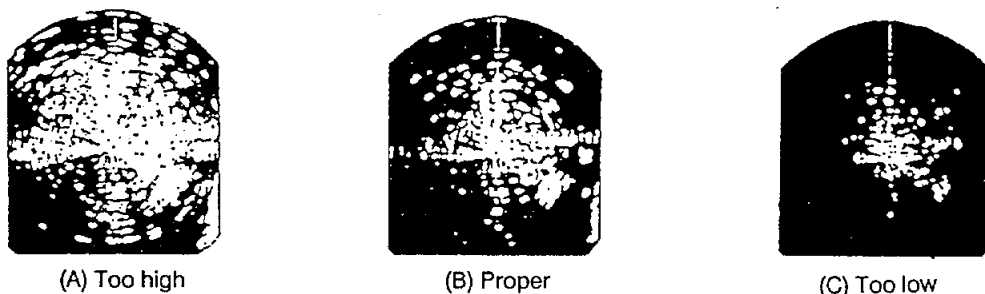

Figure 2-5 Adjusting the GAIN Control

### Tips on adjusting GAIN

- 1) In certain circumstances it may be useful to reduce the gain slightly to improve range resolution, clear up the picture, or reduce clutter caused by rain or snow.
- 2) Range resolution is a measure of the capability of a radar to display as separate pips the echoes received from two targets which are on the same bearing, and are close together radially. With reduction in the gain setting, the echoes may be made to appear as separate pips on the display.
- 3) When sailing or cruising in crowded regions a slight reduction in gain often helps to clear up the picture. This should be done carefully, otherwise weak targets may be missed.
- 4) Echoes from ships inside a squall or storm may be obscured if the gain is at its normal setting, since the clutter may have masked, but not completely, echoes from the targets.

*In all cases, return the gain to its original position after any temporary reduction is no longer required.*

## Adjusting the A/C SEA control

Echoes from waves can be troublesome, covering the central part of the display with random signals known as "sea clutter." The higher the waves, and the lower the scanner above the water, the further the clutter will extend. Sea clutter appears on the screen as a many small echoes which might affect radar performance (see Figure 2-6 (A)). The **A/C SEA** control reduces the amplification of echoes at short ranges (where clutter is the greatest) and to progressively increase amplification as the range increases, so amplification will be normal at those ranges where there is no sea clutter. The control is effective up to about 4 miles.

The proper setting of the A/C SEA should be such that the clutter is broken up into small dots, and small targets become distinguishable.

If the control is not sufficiently advanced, other targets will be hidden in the clutter, while if it is set too high, sea clutter and targets will both disappear from the screen. In most cases turn the control clockwise until clutter has disappeared to leeward, but a little is still visible windward. Figure 2-6 illustrates how to adjust the control.

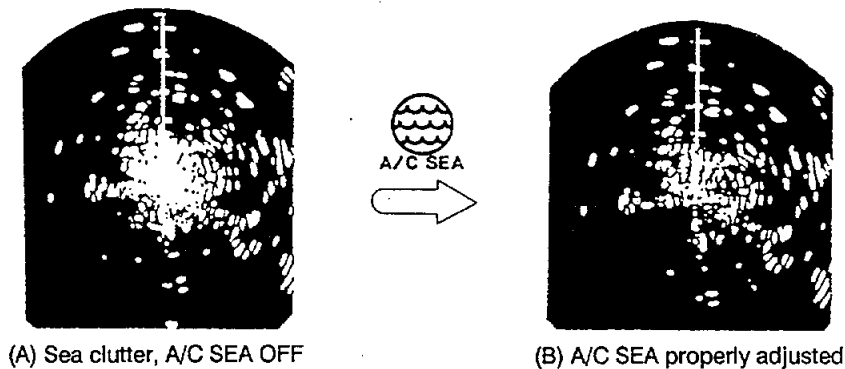

Figure 2-6 Adjusting the A/C SEA Control

### Tips on adjusting A/C SEA

- 1) *A common mistake is to over-adjust the control so all the clutter is removed. By rotating the control fully clockwise, you will see how the center of the screen becomes dark. This dark zone can be dangerous (targets may be missed), especially if the gain is not properly adjusted. Always leave a little clutter visible on the screen to be sure weak echoes will not be suppressed. If there is no clutter, leave the control in the fully counterclockwise position.*
- 2) The GAIN is normally set to the point where there is a trace of noise speckles showing on the screen on the 12 or 24 mile range, and then adjust the **A/C SEA** control on the 0.25 mile range scale so you can see close-in targets in a harbor situation clearly. This equalizes the GAIN and A/C SEA characteristics for all ranges.
- 3) In moderate conditions on the open sea, where there are no definite targets on the shorter ranges, you should still adjust the GAIN on the 12 or 24 mile range for some noise speckles on the display, and then go down to the 0.5 or 0.75 mile range to adjust the A/C SEA until you can see a bit of sea clutter close to the boat.

## Tuning the radar receiver

The radar receiver is tuned automatically each time you turn on the power, thus there is no front panel control for adjustment of the receiver. To show the automatic tuning circuit is working, a tuning bar displays tuning condition and the indication **AUTO** appears. When the circuit is not functioning properly, **AUTO** blinks. If this happens contact your FURUNO dealer or qualified technician.

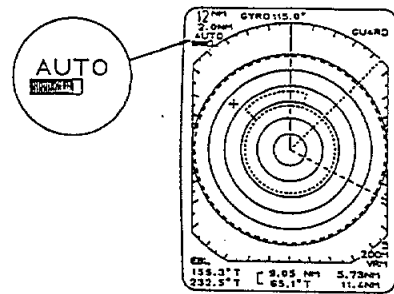



Figure 2-7  
Location of Tuning Bar and AUTO

## Adjusting display brightness

The **ZOOM/BRILL** touchpad (function indication: ) adjusts the brightness of the display in eight steps. (See "The **FUNCTION** touchpad" on the next page for how to operate this and other dual function touchpads.)

## Selecting display color

This radar paints each target echo according to its strength, in one of three ways: in red, yellow or green (three-color display, strong to weak in order), or in one of eight levels of yellow or green.

To select display color, press the **COLOR** touchpad. Each time the touchpad is pressed the color of target echoes, as well as the background and plot, change in the following sequence:

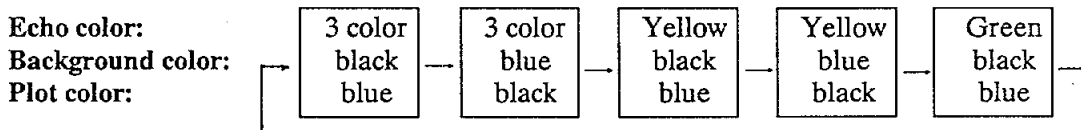



Figure 2-8 Sequence of Echo Color Selection by the **COLOR** Touchpad

## Adjusting control panel backlighting

The **PLOT/DIM** touchpad (function indication: ) adjusts the backlighting of the control panel in four steps.

## Erasing the heading mark

The heading mark continuously appears on the screen and shows ship's heading. When this mark obscures a target echo, you can temporarily erase it by pressing and holding the **HM OFF** touchpad.

## The FUNCTION Touchpad

The **FUNCTION** touchpad alternately enables the functions of the dual function touchpads (**SHIFT/NAV**, **ZOOM/BRILL**, **PLOT/DIM**, **EBL 1/2 OFF**, **OFFSET T/R**, and **VRM 1/2 OFF**). Each time the touchpad is pressed the function indication (see Figure 2-9) shifts up or down to show which function is active. For example, the functions of the **SHIFT/NAV** touchpad are shifting the display and turning the navigation data display on and off. To enable the shift function, therefore, you would press the **FUNCTION** touchpad to set the indication upward (▣).

The function indication appears also throughout the text of this manual to let you know which of its positions is required to enable a function.

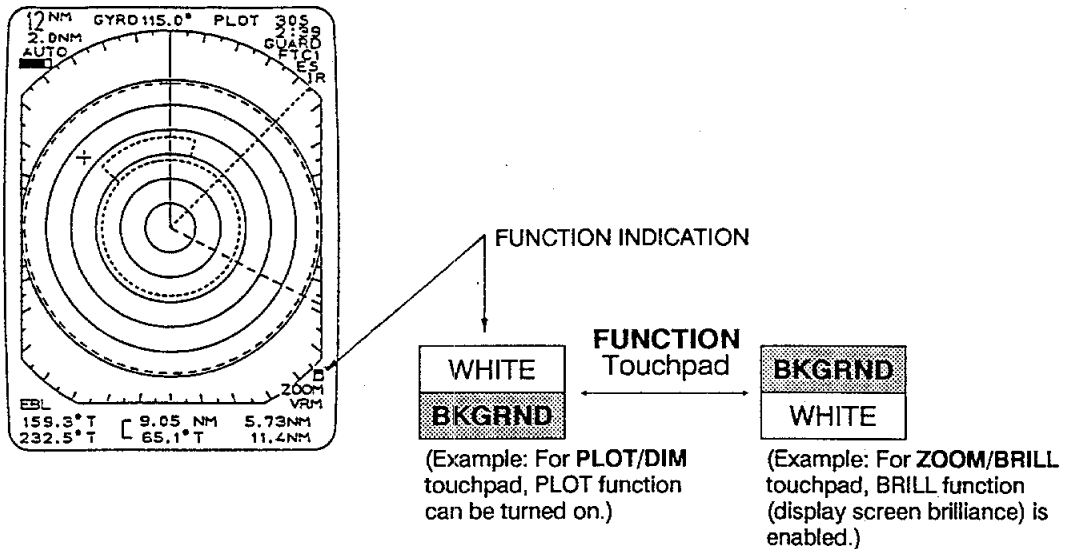

Figure 2-9 How the FUNCTION Touchpad Works

## Measuring Range and Bearing

In the basic radar system your ship is in the center of the screen, and any target received appears in a map-like projection throughout 360 degrees. This allows the bearing and range from your boat to a target appearing on the screen to be measured.

### Range

You can measure the range to a target three ways: by the fixed range rings, the cursor, or the VRM.

#### Fixed range rings

To get a rough measurement of the range to a target pip, use the fixed range rings, which are turned on and off by the **RING** touchpad. Count the number of rings between the center of the display and the target. Check the fixed range ring interval and judge the distance of the echo from the inner edge of the nearest ring. For example, the 12 nautical mile range scale has six fixed range rings, spaced 2 nautical miles apart. Therefore if a target is near the fifth ring from the center of the display, the range to the target would be about 10 nautical miles.

#### Cursor/VRM

For more accurate measurement, use the cursor or the VRM.

To measure range by the cursor, operate the trackball to place the cursor intersection on the inside edge of the target echo. The range to the target appears at the bottom of the screen.

Now try measuring range with a VRM. Press the **VRM 1/2 OFF** touchpad (function indication: ) to display a VRM. (VRM1 is the dotted ring, and VRM2 is the dashed ring. These are colored light-blue when active.) Each time the touchpad is pressed VRM1 or VRM2 is enabled or disabled and an arrow appears next to the active VRM's range readout for 5–6 seconds. Now, place the VRM on the inside edge of the target by operating the trackball. Check the range readout to find the range to the target.

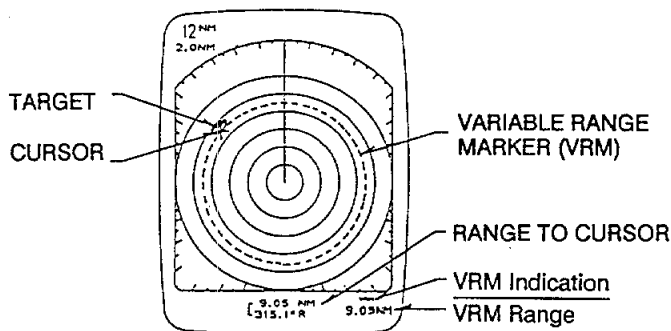

Figure 2-10 Measuring Range by the Cursor and the VRM

To turn off a VRM(s) enable the OFF function of the **VRM 1/2 OFF** touchpad and then press the touchpad.

Note that the range to the cursor always varies with trackball operation. A VRM and its indication, however, do not change unless the trackball is operated within 5–6 seconds.

**Unit of range measurement**

You can display the range readouts in nautical miles or kilometers. While pressing and holding down the **HM OFF** touchpad, press the **VRM 1/2 OFF** touchpad.

**Bearing**

There are two ways to measure the bearing of a target: by the cursor or by an Electronic Bearing Line (EBL).

**Cursor**

For an estimate of the bearing to a target, operate the trackball to place the cursor intersection on the center of the target. The bearing to the target appears at the bottom of the screen.

**EBL**

Press the **EBL 1/2 OFF** touchpad (function indication: ) to display an EBL. (EBL1 is the dotted line, and EBL2 is the dashed line. These are colored light-blue when active.) Each time the touchpad is pressed EBL1 or EBL2 is enabled or disabled and an arrow appears next to the active EBL's bearing readout for 5–6 seconds. Now, position the EBL so it bisects the target. Check the bearing readout to find the bearing of the target.

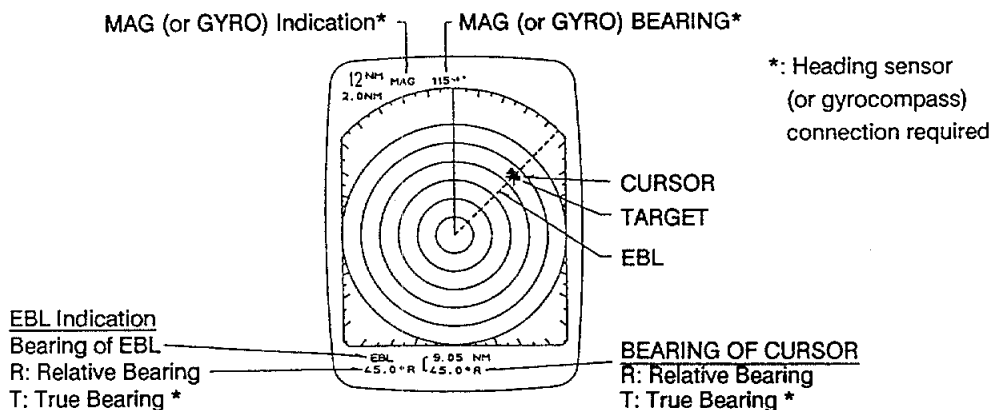



Figure 2-11 Measuring Bearing by the EBL and the Cursor

The bearing measured by the cursor or the EBL can be displayed in relative or true bearings (heading sensor or gyrocompass connection required) by pressing the **OFFSET T/R** touchpad (function indication: ). Relative bearings are relative to the bow of the vessel, and true bearings are relative to the True North. The indication “MAG” (or “GYRO”) and the heading sensor (or gyrocompass) bearing (your ship’s bearing) appear at the top of the screen.

To turn off an EBL(s) enable the OFF function of the **EBL 1/2 OFF** touchpad and then press the touchpad.

Note that the bearing to the cursor always varies with trackball operation. An EBL and its indication, however, do not change unless the trackball is operated within 5–6 seconds.

### Tips on measuring bearing

- 1) Bearing measurements of smaller targets pips are more accurate; the center of larger target pips is not as easily identified.
- 2) Bearings of stationary or slower moving targets are more accurate than bearings of faster moving targets.
- 3) To minimize bearing errors keep echoes in the outer half of the picture by changing the range scale; angular difference becomes difficult to resolve as a target approaches the center of the display.



## Reducing Interference

Basically there are three types of interference which may hinder radar reception: **sea clutter** caused by echoes reflected of waves (mentioned earlier), **precipitation clutter** due to weather conditions, and **radar interference** from other shipborne radars operating nearby on the same frequency band. This radar can eliminate or reduce these types of interference.

### Precipitation interference

The vertical beamwidth of the scanner is designed to see surface targets even when the ship is rolling. However, by this design the unit will also detect rain storms, snow, or hail in the same manner as normal targets. Precipitation clutter is easily recognizable by its wool-like appearance on-screen (see Figure 2-12). When this type of interference obscures a large area of the screen, you may use the **FTC** touchpad and/or the **A/C RAIN** control to eliminate or reduce the interference.

The **FTC** (Fast Time Constant) circuit works by splitting up these unwanted echoes into a speckled pattern, making recognition of solid targets easier. When only a slight amount of clutter is visible on the screen, turn the **A/C RAIN** control clockwise to distinguish targets from the clutter. In heavy storms or partial clutter, press the **FTC** touchpad, and then adjust the **A/C RAIN** control to reduce the clutter.

In addition to reducing clutter, the **FTC** touchpad can be used in fine weather to clarify the picture when navigating in confined waters. However, with the circuit activated the receiver is less sensitive. Therefore, turn off the circuit when there is no clutter.

With the **FTC** touchpad there are four levels of **FTC** suppression to choose from: **FTC1**, **FTC2**, **FTC3** and **OFF**.

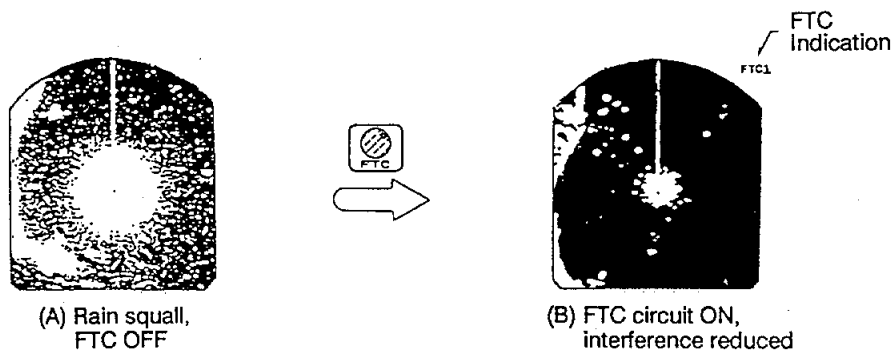

Figure 2-12 Effect of FTC

## Radar Interference

Radar interference may occur when near another shipborne radar operating in the same frequency band. Its on-screen appearance is many bright dots either scattered at random or in the form of dotted lines extending from the center (or the edge) to the edge (or the center) of the display. Figure 2-13 illustrates interference in the form of curved spokes. Interference effects are distinguishable from normal echoes because they do not appear in the same place on successive rotations of the scanner.

To reduce this type of interference, press the **IR** touchpad. The indication "IR" appears at the upper right-hand side of the screen. When there is no interference turn the circuit off, so as not to miss weak target echoes.

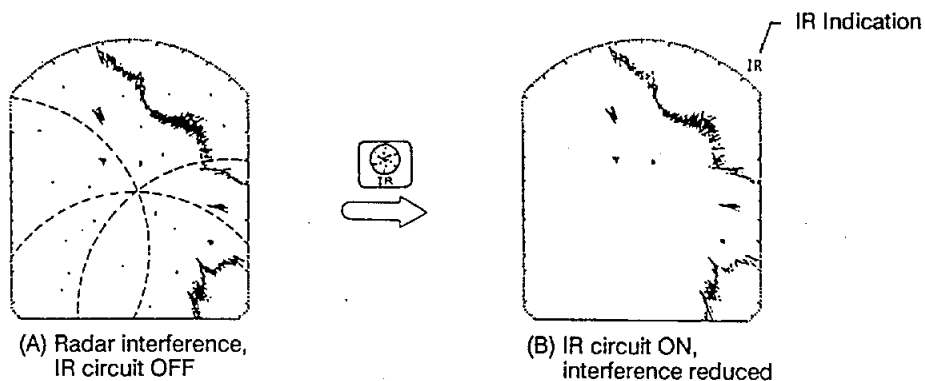



Figure 2-13 Effect of Radar Interference Rejection Circuit

## Zoom

The zoom feature allows you to double the area between own ship and an arbitrary location, to take a closer look at an area of interest without changing the range. Note that this function cannot be turned on when the shift function is on.

1. Operate the trackball to place the cursor on the target you want or area you want to zoom.

2. Press the **ZOOM/BRILL** touchpad (function indication: ). The indication **ZOOM** appears and blinks.

*NOTE: When the cursor position is not within the current range when the touchpad is pressed, an audible beep sounds and the outermost range ring blinks twice, even if the rings are off.*

3. To turn off the zoom, press the **ZOOM/BRILL** or **SHIFT/NAV** touchpad, or change the range.

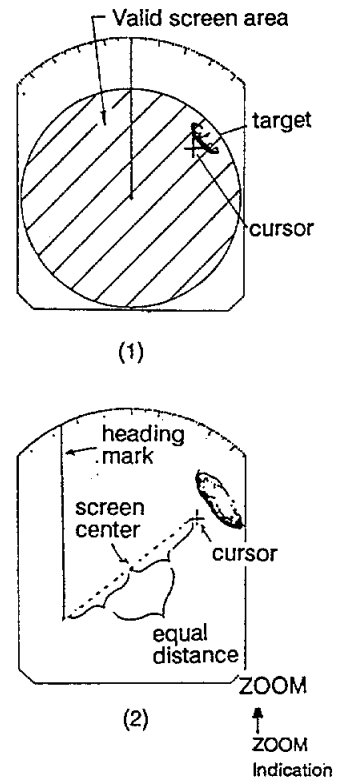

Figure 2-14 Using the Zoom Feature

## Measuring Range and Bearing Between Two Targets

The origin of EBL1 can be placed anywhere with the trackball to provide measurements of bearing and range between two targets. This function is also useful for assessing possible collision situations.

In the example below, we will find the range and bearing between targets A and B.

1. Display EBL1 on the screen. (EBL2 cannot be offset.)

*NOTE: Do each step within 5–6 seconds of the next, otherwise the later action cannot be accepted. If this occurs do the previous step again.*

2. Press the **OFFSET T/R** touchpad (function indication: ). The EBL origin jumps to the cursor location.

*NOTE: When EBL1 is not on the screen, an audible beep sounds.*

3. Operate the trackball to place the cursor on target A.

4. Press the **EBL1/2 OFF** touchpad. The EBL origin is fixed at the cursor location and the EBL can be rotated by operating the trackball.

5. Operate the trackball so the EBL bisects target B.

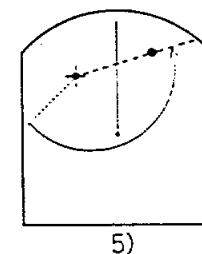
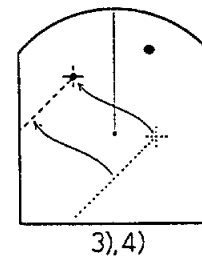
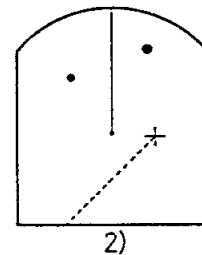
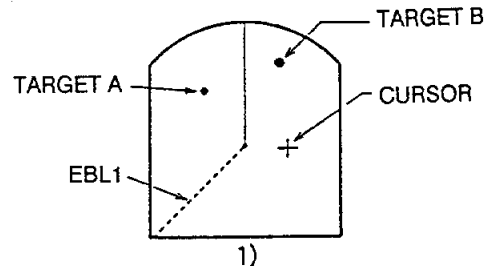

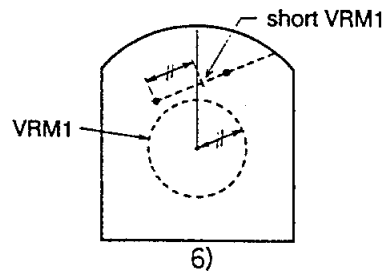

Figure 2-15(a)  
Measuring BRG Between Two Targets

6. To measure the range between target A and B, press the **VRM 1/2 OFF** (function indication: ) to display VRM1. A short VRM1 also appears on EBL1.



7. Operate the trackball to place the short VRM1 on target B. The range to the target is shown at the VRM readout.

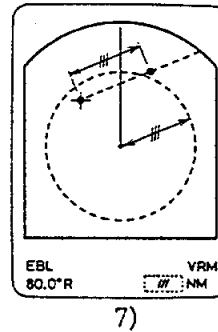

Figure 2-15(b)  
Measuring RNG Between Two Targets

---

## Guard Alarm

---

The alarm allows the operator to set the desired range (0 to maximum range) and bearing (0 to 360 degrees) for a guard zone. When ships, islands, landmasses, etc. come into the guard zone an audible alarm sounds to call the operator's attention. The alarm is very effective as an anti-collision aid when using an autopilot or navigating in narrow channels.

### CAUTION

*The alarm is a useful anti-collision aid, but does not relieve the operator of the responsibility to also keep a visual look-out for possible collision situations. The alarm should not be relied upon as the sole means for detecting possible collision situations. The 1972 Convention on the International Regulations For Preventing Collisions at Sea (1972 COLREGS) provides statutory requirements for the operation of any vessel, including the posting of lookouts. The operator of the vessel is responsible for compliance with those requirements whether or not a radar is in use.*

Before setting the alarm, be sure the **GAIN** control is properly adjusted, because the audible alarm sounds when the sixth or seventh level quantization echoes (or red color echoes for the three-color display) come into the guard zone.

1. Mentally create the guard zone you want to display on-screen. See Figure 2-16 (1).
2. Set the upper (lower) left edge of the guard zone with the cursor. Press the **GUARD** touchpad. The indication "**\*GUARD**" (asterisk blinking) appears at the upper right-hand side of the screen. (See Figure 2-16 (2).) The asterisk indicates the guard zone is partially set, but the alarm function has been actuated. It disappears once the guard zone is set completely.
3. Moving the trackball clockwise, set the lower (upper) right edge of the guard zone. The guard zone now appears on the display. See Figure 2-16 (3).

*NOTE: To create a 360 degree guard zone, rotate the cursor counterclockwise instead of clockwise.*

4. Press the **GUARD** touchpad again. The asterisk disappears and the color of the guard zone changes to white. See Figure 2-16 (4).
5. Any ships, landmasses, etc. coming into the guard zone will trigger the audible alarm. If the audible alarm sounds you can silence it by pressing the **GUARD** touchpad. When this is done the indication "**GUARD**" appears in reverse video.
6. Press the **GUARD** touchpad again to restore the audible alarm. "**GUARD**" appears in white.
7. To cancel both the guard zone and the audible alarm, press and hold down the **GUARD** touchpad for at least two seconds.

*Note 1: When the range is less than the guard zone range, the guard zone disappears from the screen. If this happens, select a range which will again display the guard zone on the screen.*

*2: A target echo does not always mean a landmass, reef, ships or surface objects but can imply returns from sea surface or precipitation. As the level of these returns varies with environment, the operator should (properly) adjust the A/C SEA, A/C RAIN, FTC and GAIN to be sure target echoes within the guard zone are not overlooked by the alarm system.*

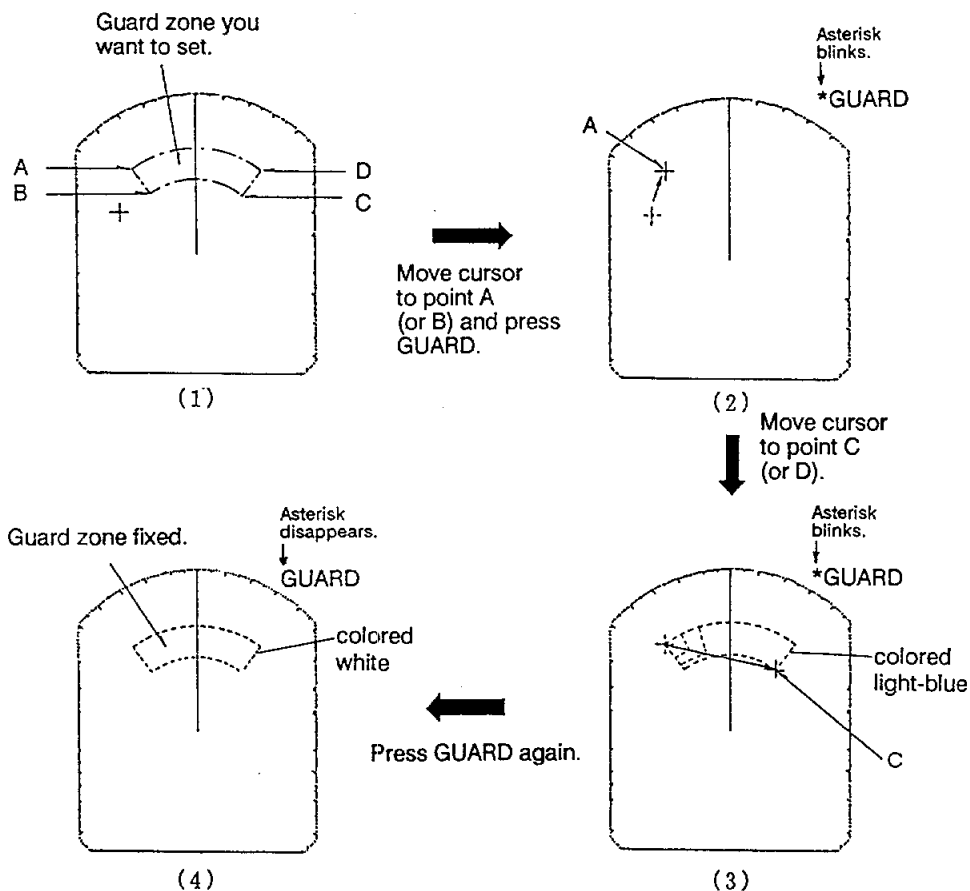



Figure 2-16 Setting Guard Zone

---

## Shifting the Display

---

The own ship's position can be shifted to any position within the current range. The primary advantage of the shifted display is that for any range setting, the view ahead of your own ship can be extended without changing the range.

Place the cursor where you want the screen center to be and then press the **SHIFT/NAV** touchpad (function indication: ). To restore normal operation press the touchpad again.

*NOTE: If the cursor is not within the current range when the touchpad is pressed, an audible beep sounds and the outermost range ring blinks twice, even if the range rings are off.*

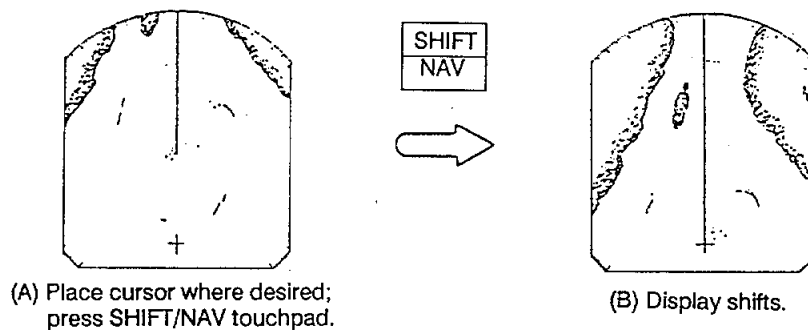



Figure 2-17 Shifting the Display



## Plotting

This function plots the movement of other ships relative to your own ship.

Press the **PLOT/DIM** touchpad (function indication: ) to start plotting. The indication **PLOT** and a timer appear at the top right-hand corner of the screen and targets are plotted in blue or black depending on color selection. The timer counts up from 0:01 to 99:59, whereupon the timer indication freezes but plotting continues. Targets initially are updated every 15 seconds. However, you can select intervals of 30 seconds, 1 minute, 3 minutes and 6 minutes by pressing the **PLOT/DIM** touchpad within 10 seconds of the previous pressing. The plotting interval (except for 15 seconds) appears to the right of the indication **PLOT**.

If the range is changed during plotting, plotting begins anew with the newly selected range.

To cancel plotting, press the touchpad.

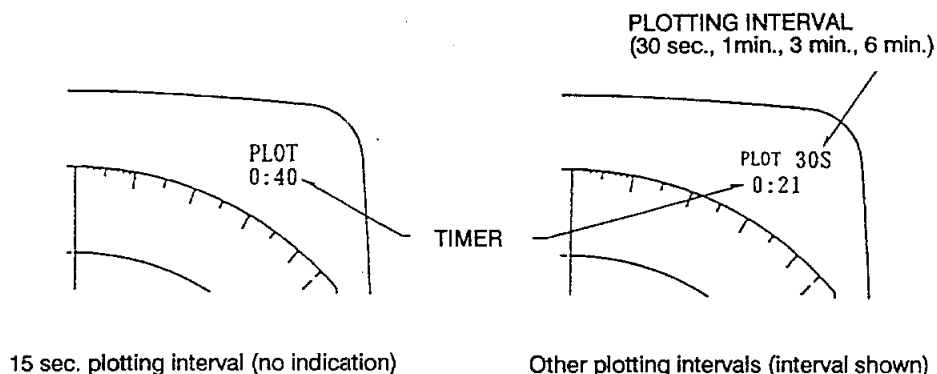



Figure 2-18 Plotting Indications

## Navigation Data

Navigation data can be displayed on the screen if this radar receives navigation input from a Loran-C, NNSS (satellite navigator) or GPS navigator whose output format is NMEA 0183 or FURUNO CIF. Data displayable include own ship's position in latitude and longitude (or Loran-C time differences (TDs)), bearing and range to a waypoint selected on the nav aid, and own ship's speed. In addition, if a gyrocompass or heading sensor is connected, a line connects a waypoint, denoted by a light-blue dashed ring, with the own ship's position.

To turn the navigation data display on or off, press the **SHIFT/NAV** touchpad (function indication: ).

To display TDs instead of L/L, while pressing and holding down the **HM OFF** touchpad, press the **SHIFT/NAV** touchpad (function indication: ).

*If the output format is FURUNO CIF a jumper wire must be connected to "JPI" on the SPU Board in the display unit. (See the note below. For the location of JPI, see Figure 5-2.) Note that for CIF format the bearing measurement method (Magnetic or True) does not appear for bearing to waypoint data.*

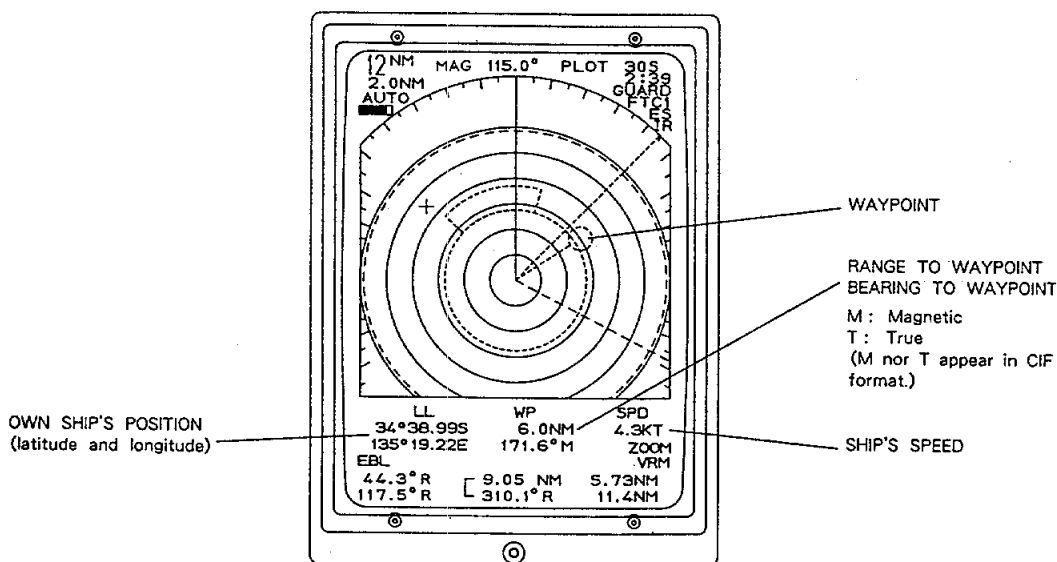

Figure 2-19 Navigation Data on the Screen

### DANGER

Making modifications to this equipment may involve exposure to high voltage which can cause severe personal injury or death. Work of this nature should be performed only by a qualified service technician.

---

## Better Distinction of Echoes

---

Normally, the reflected echoes from long distance targets appear on the screen as weaker and smaller blips even though they are compensated by the radar's internal circuitry. The **ECHO STRETCH** touchpad magnifies these small blips in all ranges.

When the echo stretch function is on, the indication "ES" appears at the upper right-hand side of the screen and the echoes are doubled lengthwise.

To turn off the echo stretch, press the touchpad again.

*NOTE: This function magnifies not only targets but also sea clutter and radar interference. For this reason be sure the controls for adjustment of sea clutter and radar interference are properly adjusted before activating the echo stretch.*

This page intentionally left blank.

---

## 3. APPLICATION

As an aid to navigation, radar can be a very valuable tool. No other navigation aid can give you the ability to spot vessels coming at you in the fog, or tell you the location of the inlet to the harbor in the pitch black of night. To help you understand better what your radar can and cannot do for you this section covers the characteristics and limitations of radar, picture interpretation, and position fixing with radar.

---

### Factors Affecting Minimum Range

---

Targets disappearing from the screen when at close ranges can be dangerous. For this reason, detection of targets at short ranges is very important. Minimum range is determined primarily by transmitter pulselength. The shorter the transmission time, the sooner the return echoes can be received and their distance measured. This radar automatically determines the pulselength for both short and long ranges, for optimal detection of targets on all ranges.

#### Sea return

Sea clutter echoes received from waves may hamper detection of targets beyond the minimum range set by the pulselength and recovery time. (Recovery time is the time required for the receiver to recover to half sensitivity after the end of a transmitted pulse, so it can receive a return echo.) Proper adjustment of the **A/C SEA** control may alleviate some of the problem.

#### Vertical beamwidth

The ability to see targets very close to the boat is decreased if the antenna is mounted too high off the water, since the bottom of the vertical beam of the scanner cuts off nearby targets. Figure 3-1 illustrates the effects of a scanner mounted too high off the water.

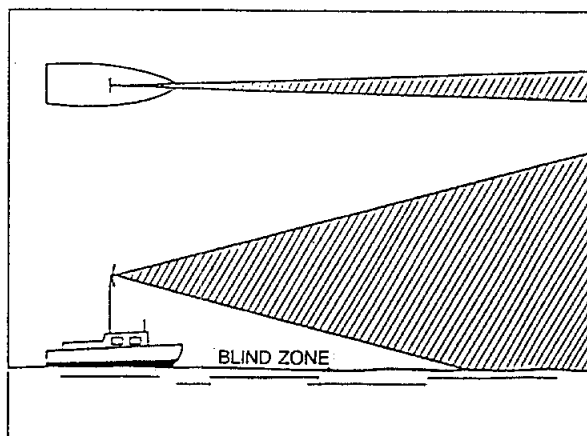

Figure 3-1 Effects of a Scanner Mounted too High off the Water

---

## Factors Affecting Maximum Range

---

It is nearly impossible to state that a radar has a maximum range. The maximum range a radar will "see" is dependent on many factors, not just the range marked on the screen. Not only does the sensitivity of the receiver and power of the transmitter but also the height above the water of both the scanner and target, the size, shape and composition of the target, and atmospheric conditions contribute to increase or decrease the maximum detectable range.

### Radar horizon

Radar is by its very nature essentially a "line-of-sight" phenomenon. That means that you have just about the same range to horizon with a radar as you do with your own eyes. However under normal atmospheric conditions, the radar horizon is 6% greater than the optical horizon. Therefore, if the target does not rise above the horizon the radar beam cannot be reflected from the target.

Just as you can see a low-to-the-water speedboat only up relatively close to your boat, the radar can see a target high off the water farther than it can see an object which is close to the water. Further, the higher the antenna is mounted over the water the farther it is capable of seeing other targets. However a possible negative effect with mounting the antenna too high off the water is that due to the finite vertical beamwidth of the scanner, the amount of sea clutter due to reflections from nearby waves is increased to a greater distance from the boat.

Thus it is not at all uncommon to see a 3000 foot high mountain 50 miles away (provided the radar has a 50 nautical mile detection capability), while at the same time being only able to see a small power boat 3 or 4 miles away. (See Figure 3-2.)

The distance to the horizon from the scanner, under normal conditions, is calculated by the following formula.

$$R_{\max} = 2.2 \times (\sqrt{h_1} + \sqrt{h_2})$$

Where  $R_{\max}$ : Radar horizon (mile),  $h_1$ : Antenna height (meters),  $h_2$ : Target height (meters)

For example, to find the distance to the horizon in Figure 3-2, if the antenna height is 8 meters (26 feet) and the target height is 15.2 meters (50 feet) the maximum range is (when the cliff begins to appear on the radar),

$$R_{\max} = 2.2 \times (\sqrt{8} + \sqrt{15.2}) = 14.8 \text{ miles.}$$

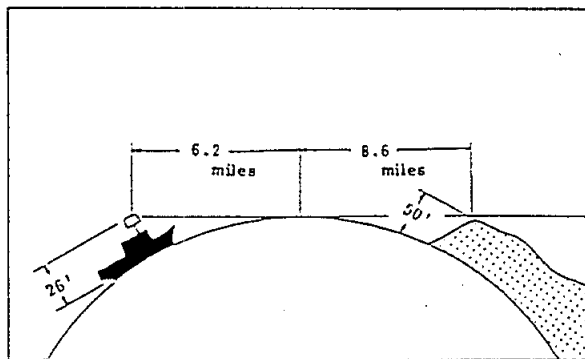

Figure 3-2 Radar Horizon

### Target properties

Generally, larger targets can be seen on the radar display at greater ranges, provided line-of-sight exists between the scanner and target. However, a large target with poor reflecting properties may not be detected as easily as a smaller target with better reflecting properties.

Since one of the main functions of radar is to detect other ships, the composition of a target ships' hull affects the detection range. A ship whose hull is made of conducting materials, such as steel, will return a relatively strong echo.

On the other hand, hulls made from wood or fiberglass return much weaker echoes.

Vertical surfaces, such as a cliff, are good targets provided they face the radar. Conversely, horizontal and smooth surfaces such as mudbanks, sandy beaches, and gently sloping hills make poor targets because they disperse rather than reflect most of the energy that strikes them.

The strongest radar echoes known come from built-up areas, docks, etc., because these targets are less subject to changes in aspect. These types of targets have three flat, smooth surfaces mutually at right angles. Some radar buoys are arranged this way so as to deliberately increase their detection range.

---

## Interpreting the Display

---

In the previous section some of the characteristics and limitations of radar were discussed. Now its time to take a look at what you can expect to see on the radar screen. What shows up on the screen isn't likely to match exactly what is seen on a navigation chart. A radar cannot see through a mountain in the path between your boat and the harbor, nor can it see a small boat directly behind a large ship, since both the mountain and the larger vessel effectively shield the radar from the desired target.

To aid you in target identification, the echoes appearing on the display are quantized in eight levels (or displayed in three colors), according to their intensity. The brightest intensity echoes are probably from steel ships, or piers, or other "good" targets. Poor targets, for example, wooden boats, appear in the weakest intensities.

The ability to interpret a radar picture comes through practice and experience. Practice should be done during clear weather in daytime, since you can compare the picture with what you actually see around you. Go to an area you are familiar with and compare the way coastlines, buoys and other targets appear on the screen and the way they are drawn on a navigation chart. To observe the movement of an echo in relation to your position, try running your boat at various speeds and headings.

### Land targets

Landmasses are readily recognizable because of the generally steady brilliance of the relatively large areas painted on the display. Knowledge of the ship's navigational position will also tell you where land should be. On relative motion displays (this radar), landmasses move in directions and at rates opposite and equal to the actual motion of your own ship. Various factors such as distortion from beamwidth and pulselength make identification of specific features difficult. However, the following may serve as an aid to identification.

- 1) High, steep, rocky and barren landmasses provide good reflecting surfaces.
- 2) Low, vegetation covered lands make poor radar targets.
- 3) Submerged objects do not produce echoes.
- 4) Mud flats, marshes, sandspits, and smooth, clear beaches make poor targets because they have almost no area that can reflect energy back to the radar.
- 5) Smooth water surfaces such as lagoons and inland lakes appear as blank areas on the display – smooth water surfaces return no energy.
- 6) Although you might expect an object as large as a lighthouse to be a good radar target, in actuality the return echo is weak since the conical shape diffuses most of the radiated energy.



## Ship targets

A bright, steady, clearly defined image appearing on the display is in all likelihood the target pip of a steel ship. There are several clues which can aid you in identification of a ship. Check your navigational position to rule out the possibility that a target pip is actually a landmass. Land and precipitation echoes are much more massive in appearance than the target pips of ships—which are relatively small. The rate of movement can eliminate the possibility that the pip is an aircraft.

A target pip may brighten and become dim due to changes in aspect and other factors. In most cases however a pip will fade from the display only when the range becomes too great.

## Echo size

As the radar beam rotates, the appearance of a pip on the display screen will begin as soon as the leading edge of the radar beam strikes the target. The pip will continue to be seen on the display screen until the trailing edge of the beam rotates beyond the target. Thus, a target cannot appear less wide than the beamwidth. As the beam widens with distance from the scanner, so also will the widths of targets vary on the display. Figure 3-3 illustrates the relationship between beamwidth and the appearance of a target pip.

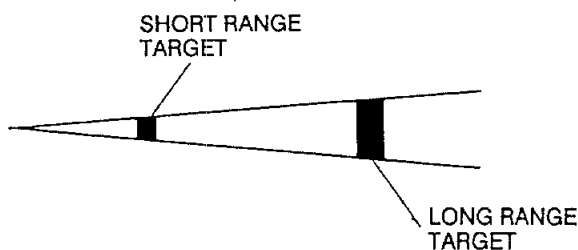

Figure 3-3 Beamwidth Versus Target Appearance

---

## False Echoes

---

Occasionally false echoes appear on the screen at positions where there is no target. In some cases the effects can be reduced or eliminated. The operator should familiarize himself with the appearance and effects of these false echoes, so as not to confuse them with echoes from legitimate contacts.

### Multiple echoes

Multiple echoes occur when a short range, strong echo is received from a ship, bridge, or breakwater. A second, a third or more echoes may be observed on the display at double, triple or other multiples of the actual range of the target as shown in Figure 3-4. Multiple reflection echoes can be reduced and often removed by decreasing the gain or properly adjusting the A/C SEA.

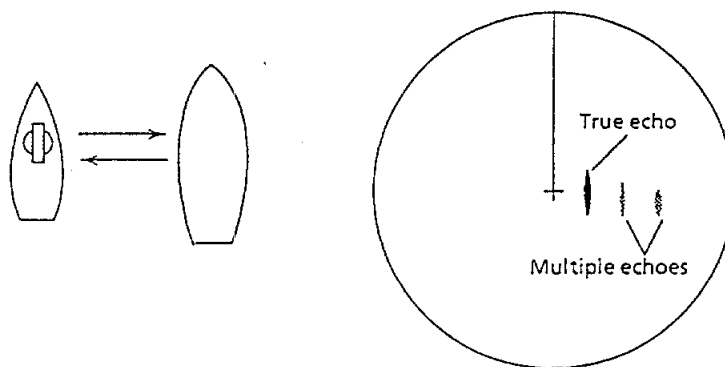

Figure 3-4 Multiple Echoes

### Side-Lobe echoes

Every time the scanner rotates, some radiation escapes on each side of the beam—called "side-lobes." If a target exists where it can be detected by the side-lobes as well as the main lobe, the side echoes may be represented on both sides of the true echo at the same range, as shown in Figure 3-5. Side-lobes show usually only at short ranges and from strong targets. They can be reduced through careful reduction of the gain or proper adjustment of the A/C SEA control.

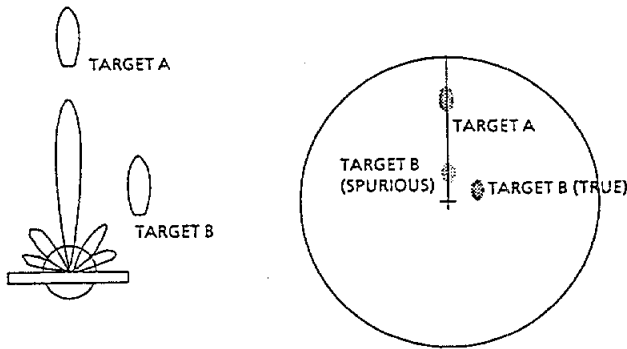

Figure 3-5 Side-Lobe Echoes

### Blind and shadow sectors

Funnels, stacks, masts, or derricks in the path of antenna may reduce the intensity of the radar beam. If the angle subtended at the scanner is more than a few degrees a blind sector may be produced. Within the blind sector small targets at close range may not be detected while larger targets at much greater ranges may be detected. See Figure 3-6.

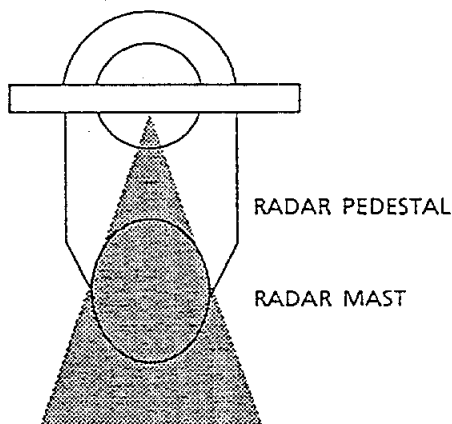

Figure 3-6 Blind and Shadow Sectors

### Indirect echoes

Indirect echoes may be returned from either a passing ship or returned from a reflecting surface on your own ship, for example, a stack. In both cases, the echo will return from a legitimate contact to the antenna by the same indirect path. The echo will appear on the same bearing of the reflected surface, but at the same range as the direct echo. Figure 3-7 illustrates the effect of an indirect echo. Indirect echoes may be recognized as follows. (1) they usually occur in a shadow sector; (2) they appear on the bearing of the obstruction but at the range of the legitimate contact; (3) when plotted, their movements are usually abnormal, and (4) their shapes may indicate that they are not direct echoes.

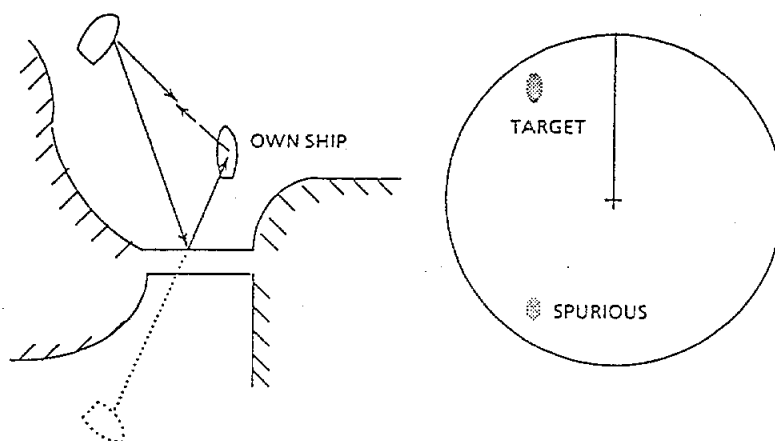

Figure 3-7 Indirect Echoes

## Radar Picture and Corresponding Chart

Under normal conditions, a picture which is very similar to a chart can be obtained on the radar display. The radar picture and corresponding chart shown in Figure 3-8 are from the Kada Inland Sea, south of Osaka Bay, in Southwestern Japan.

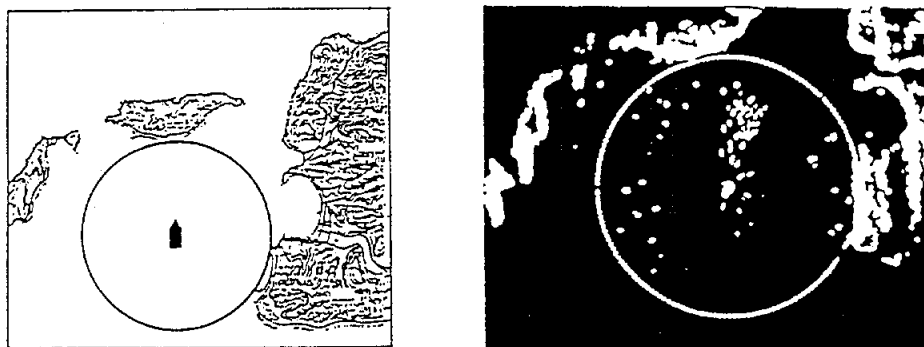

Figure 3-8 Navigation Chart and Corresponding Radar Picture

---

## Position Fixing with Radar

---

Position fixing with radar can be accurately achieved once you become proficient in the different methods. The three most common methods will be discussed in this section. Take a compass and a navigation chart and try to fix your position while reviewing this section.

### By radar range

The simultaneous measurement of the ranges to two or more fixed objects is normally the most accurate method of obtaining a fix with radar alone. Preferably at least three ranges should be used. However the use of more than three range arcs may introduce excessive error because of the time lag between measurements, namely, you will be moving as you take successive measurements.

When obtaining a fix, it is best to measure the most rapidly changing range last because of a smaller time lag in the radar plot from the ship's actual position. For greater accuracy, the objects selected should provide arcs with angles of cut as close to 90 degrees as possible. Small, isolated, radar-conspicuous fixed objects whose associated range arcs intersect at angles approaching 90 degrees provide the most reliable and accurate position fixes. Objects at longer ranges are less accurate for position fixing because they may be below the radar horizon and because the width of the radar beam increases with range.

To fix your position, first, measure the range to two or more prominent navigational marks which you can identify on the chart. Next, with the compass sweep out the ranges from the charted positions. The point of intersection of the arcs is your estimated position. The method of position fixing by radar range is illustrated in Figure 3-9.

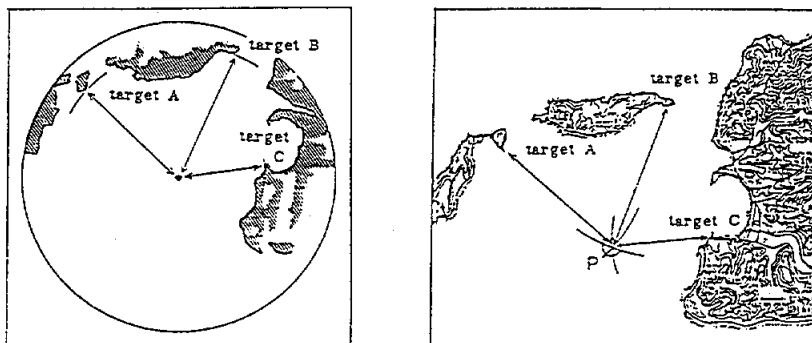

Figure 3-9 Position Fixing Using Radar Ranges

### By range and bearing to a point of land

The advantage of position fixing by range and bearing to a point of land is the speed with which a fix can be obtained. A distinct disadvantage however is that this method is based upon only two intersecting position lines, a bearing line and range, obtained from two points of land. If possible, the object used should be small, isolated and identified with reasonable certainty. To fix your position using range and radar bearing, first, measure the relative

bearing of the target with the EBL, noting the exact direction of the ship's heading when doing so. Next, make allowance for compass deviation (true or magnetic) and find the true bearing of the target. Sweep out the range to the target with the compass on the chart and plot the true bearing of the target. The point of intersection is your approximate position. Figure 3-10 illustrates how to fix position by using a range and bearing to a point of land.

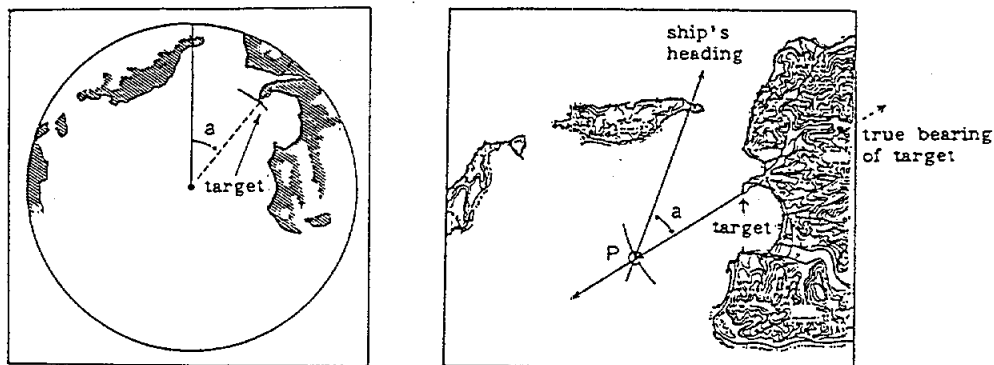

Figure 3-10 Position Fixing Using Range and Bearing to a Point of Land

### By two bearings

Generally, fixes obtained from radar bearing are less accurate than those obtained from intersecting range arcs. The accuracy of fixing by this method is greater when the center bearings of small, isolated radar-conspicuous objects can be observed. Similar to position fixing using range and bearing, this method affords a quick means for initially determining approximate position. The position should then be checked against other means to confirm reliability.

Position fixing using two bearings is determined by measuring the relative bearings for the two targets and then determining their true bearings. Plot the two bearings on the chart; the point of intersection of the two bearings is your approximate position. Figure 3-11 illustrates the method of position fixing using two bearings.

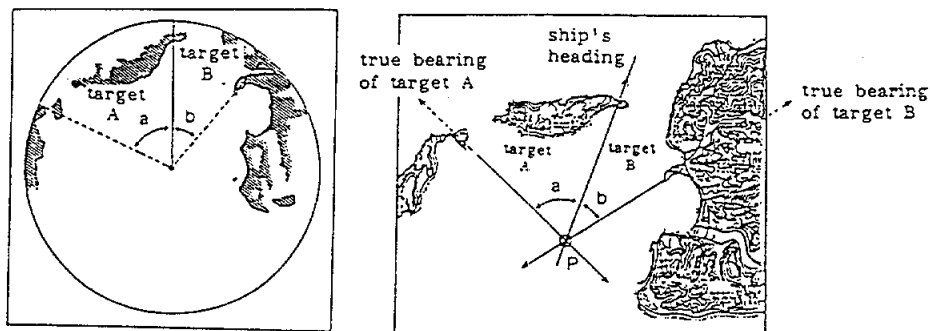

Figure 3-11 Position Fixing Using Two Bearings

## Collision Avoidance and Relative Motion

### CAUTION

*The 1972 Convention on the International Regulations for Preventing Collisions at Sea (1972 COLREGS) provides statutory requirements for the operation of any vessel, including the posting of lookouts. The operator of the vessel is responsible for compliance with those requirements whether or not a radar is in use.*

Collisions at sea sometimes occur because the radar picture doesn't match the information provided by the eye in clear weather and because of the misunderstanding of relative motion.

In a relative motion display, your ship is represented by the spot of light fixed at the center of the screen, regardless of the speed of your own ship. With both your own ship and the target in motion, the successive pips of the target do not indicate the actual or true movement of the target. If your own ship is in motion, the pips of fixed objects, such as land masses, move on the display at a rate equal to and in a direction opposite to the motion of your own ship. Only when your ship is stopped or motionless do target pips move on the display in accordance with their true motion. Figure 3-12 illustrates the relative and true motion of a target contacted by radar.

In Figure 3-12, ship A, at geographic position A1 on true course of 001° at 14 knots initially observes ship B on the PPI at bearing 179° at 4.1 nautical miles. The bearing and distance to the ship changes as ship A proceeds from position A1 to A3. The changes in the position of ship B relative ship A are illustrated in the successive PPI presentations corresponding to the geographic positions of ships A and B. Likewise, ship B at geographic position B1, on true course 25° at 21 knots initially observes ship A on bearing 001° at 4.1 nautical miles.

The radar operator aboard ship A will determine that relative movement of ship B is approximately 66.5 degrees, whereas the operator aboard ship B will determine that the relative movement of ship A is approximately 238 degrees. These figures were obtained using a maneuvering board.

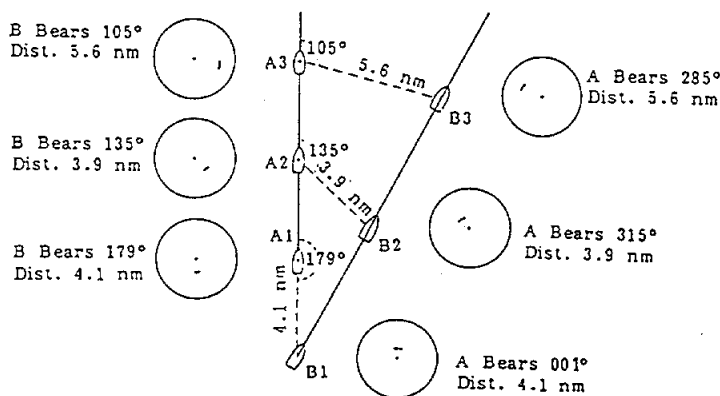

Figure 3-12 Relative Motion Versus True Motion

### **Assessing the risk**

The moment an echo appears on the screen its range and relative bearing should be measured and its true or magnetic bearing noted. This is best done on a chart or plot. Collision risk can be assessed only by carefully watching the true or magnetic bearing of an approaching vessel. If the bearing of the target does not appreciably change a possibility of collision may exist.



---

## 4. MAINTENANCE

---

### General

---

Regular maintenance is important for good performance. Following the procedures prescribed in this section will help keep your unit in good working order for many years.

Always keep the equipment as free as possible from dirt, dust and water splashes. Make sure that all screws securing the components are properly tightened.

### **DANGER ELECTRICAL SHOCK HAZARD**

This equipment uses high voltage electricity which can endanger human life. At several places in the unit there are high voltages sufficient to kill anyone coming in direct contact with them. While the equipment has been designed with consideration for the operator's safety, precautions must always be exercised when reaching inside the equipment for the purpose of maintenance and/or service. For this reason, only qualified personnel totally familiar with electrical circuits and service manual should work inside the display unit or scanner unit.

*CAUTION: To prevent possible personal injury from radio frequency (RF) radiation hazards, make certain that no one is near the scanner before turning on the radar.*

---

### Scanner Unit

---

#### Radome

Wipe the radome with a clean soft cloth. Check that there is no dirt or caked salt on the surface. A heavy deposit of dirt or caked salt on the radome will cause a considerable drop in radar performance. Do not use chemical cleaners except for alcohol. Also, check for cracks on the surface. If any cracks are found, they should be temporarily repaired by using a small amount of sealing compound or adhesive and the unit should then be brought to your local dealer for permanent repairs. A crack on the surface or deterioration of the rubber packing will cause permanent damage to the internal circuitry due to water leakage. Do not paint the radome.

#### Mounting base

Periodically confirm that the radome base and radome cover fixing bolts are secured tightly.

---

## Display Unit

---

### Cleaning the display screen

The face of the display screen will, in time, accumulate a coating of dust which tends to dim the picture. Clean lightly with a soft cloth, moistened with alcohol or cleaning fluid if desired. Do not use excess pressure; you may scratch the surface.

### Fuse replacement

To protect the equipment from serious damage, a 15A (for 12 VDC mains) or 10A (for 24/32 VDC mains) fuse is provided on the rear panel of the display unit. The fuse protects against overvoltage/reverse polarity of the ship's mains or internal fault of the equipment. If the fuse blows, first find the problem before replacing it with a new one. **Never use a fuse rated for more than 15A or 10A, since it may cause serious damage to the equipment. OVER FUSING WILL VOID THE WARRANTY.**

---

## 5. TROUBLESHOOTING

This section provides troubleshooting information for the user and the service technician.  
**TO THE USER:** If something appears to be wrong with your unit, check it by referring to the "Basic Troubleshooting" section. If you cannot restore normal operation, contact your Furuno dealer or qualified technician.

### **DANGER ELECTRICAL SHOCK HAZARD**

This equipment uses high voltage electricity which can endanger human life. At several places in the unit there are high voltages sufficient to kill anyone coming in direct contact with them. While the equipment has been designed with consideration for the operator's safety, precautions must always be exercised when reaching inside the equipment for the purpose of maintenance and/or service. Only personnel totally familiar with electrical circuits and service manual should work inside the display unit or scanner unit.

**TO THE SERVICE TECHNICIAN:** Always make sure that the electrical power is turned off before attempting to change a component or inspecting the inside of the equipment. A residual charge may also exist in capacitors, even with the equipment turned off. Therefore, always short all supply lines to the chassis with an insulated screwdriver or a similar tool before touching the circuit.

### **WARNING: RADIO FREQUENCY (RF) RADIATION HAZARD**

*This radar scanner emits high frequency radio radiation which can be harmful, particularly to your eyes. Never look directly into the scanner from a distance of less than two feet when the radar is in operation as you could injure the cornea of your eyes. Always make sure that the radar is set to either Stand-By or OFF before starting work on the scanner.*

---

## Basic Troubleshooting

---

In most cases when the unit fails to operate properly the cause is very simple. Before calling for service or sending out the unit for repairs, check the following.

**1) Nothing appears on screen. (Check that the front panel is illuminated. If it is not, check the following.)**

- Is the battery dead?
- Is the fuse blown?
- Supply voltage is normal?
- Corroded battery terminals?
- Poor contact of power cable?

**2) No echo but numerical and character indications.**

- Is the antenna plug loose?

**3) Low sensitivity.**

- Is the GAIN too low?
- Is the A/C SEA too high?
- Is the FTC ON?
- Is the brilliance too low?
- Is the receiver detuned? (AUTO indication blinks.)
- Is the radome dirty?

**4) Noise on screen.**

- Is the unit grounded?

**5) Sweep not rotating.**

- Is the **SCANNER** switch turned on? See Figure 6-15 on page 6-16.
- Is the antenna plug loose?
- Is the 4-way connector (P/J802) inside the scanner loose? See Figure 6-7 on page 6-7.

---

## Advanced Troubleshooting

---

Advanced troubleshooting, replacement of defective parts and repair of this equipment involves exposure to high voltage capacitors which can cause severe personal injury or death. **Only qualified personnel totally familiar with electrical circuits and service manual should work inside the display unit or scanner unit.**

Before beginning work inside either unit, read the safety information at the beginning of this chapter.

### Typical problems and their causes

**1) Power cannot be turned on (panel does not light).**

- Defective FIL Board.
- POWER SUPPLY Board. Measure voltage between J1301 #1(+) and #4(-) on the POWER SUPPLY Board. It should be 10.2 to 20.3 VDC for 12 VDC systems, or 20.4 to 40.0 VDC for 24 and 32 volt systems. See Figure 5-1 on page 5-5.

**2) Power can be applied but nothing appears on the display.**

- Check if the CRT heater is lit. If it is lit, the CRT is functioning normally.
- CRT high voltage.
- CRT SOCKET Board, MAIN Board. Adjust potentiometer VR6 (INT BRT) on the MAIN Board to display radar echoes. If not possible, CRT unit may be defective.
- Defective SPU Board (SPU-8760).

**3) Scanner does not rotate or rotates too fast/slow.**

- SCANNER switch in VR compartment is off.
- Jammed scanner rotating mechanism.
- Defective scanner motor (B801).
- Defective motor control circuit.

**4) Picture out of synch.**

- Defective SPU Board (SPU-8760).
- MAIN Board of CRT assembly. On the MAIN Board, adjust potentiometers VR5 (H FREQ) and VR1 (V FREQ) for vertical and horizontal synchronization, respectively.

**5) Sweep rotation is not synchronized with antenna rotation.**

- Defective bearing pulse generator circuit in scanner unit.
- Defective SPU Board (SPU-8760).

**6) No bearing signal (BP SIG MISSING appears on screen in the "ST-BY" mode).**

- Loose connector DJ/DP-1 on the display unit.
- Defective SPU Board (SPU-8760).

**7) Marks and legends appear but no echo nor noise appear.**

- Discontinuity or short circuit of video signal coaxial cable.
- Defective IF Board (IF-7758).
- Defective SPU Board (SPU-8760).

**8) Poor sensitivity.**

- Deteriorated magnetron (V801). Refer to "CHECKING THE MAGNETRON" (below).
- Detuned MIC (U801).
- Confirm the TUNE Switch (S2) on the ADJ Board is set to AUTO TUNE. See Figure 6-15 on page 6-16.

**9) Noise, marks and indications appears but no echo.**

- Defective SPU Board (SPU-8760).
- Discontinuity of trigger line of video signal coaxial cable.
- Defective MD Board (MD-7918).
- Magnetron heater voltage not applied. Refer to page 6-20.
- Defective magnetron (V801). Refer to "CHECKING THE MAGNETRON" (below).

**10) Radar is out of tune.**

- Frequency deviation of the magnetron. Refer to "AUTO TUNING" on page 6-16.

---

## Checking the Magnetron

---

Fewer echoes appear on the screen when the magnetron has deteriorated. To determine magnetron suitability, measure the magnetron current. For the location of parts, see Figures 5-2 and 5-3.

1. Turn OFF the **SCANNER** switch in the VR compartment of the display unit to temporarily stop antenna rotation. See Figure 6-15 on page 6-16.
2. Connect a multimeter, set to 10 VDC range, to pin #5(+) and #6(-) of TP803 on the MD Board (MD-7918) in the scanner unit.
3. Once turn off the radar system. Then, turn on DIP Switch S1 #1 on the SPU Board inside the display unit. Transmit the radar on the 0.25 nm range.
4. Confirm that the magnetron current (voltage) is 0.5 to 1.2 VDC.
5. Change the range setting to 24 nm range and confirm that the voltage is 0.9 to 1.1 VDC.
6. If the voltage is far out of the range specified above, the magnetron may be defective. Turn off DIP Switch S1 #1 and turn on the **SCANNER** switch.

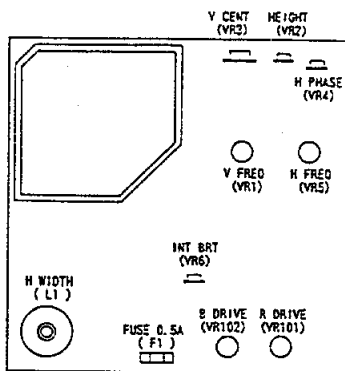

MAIN BOARD

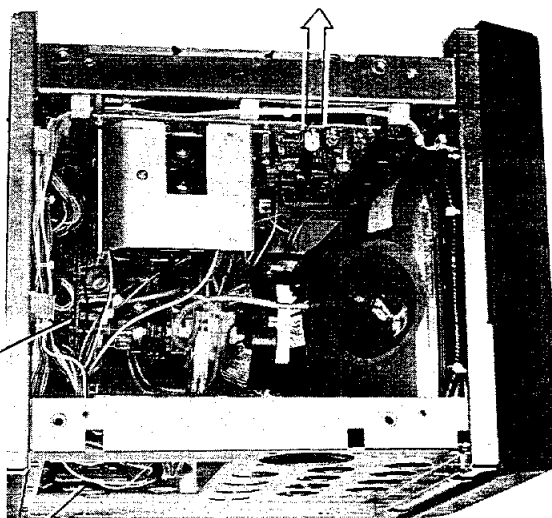

TOP VIEW

CRT SOCKET Board

N Photo No.2852

POWER SUPPLY Board  
PTU-8764

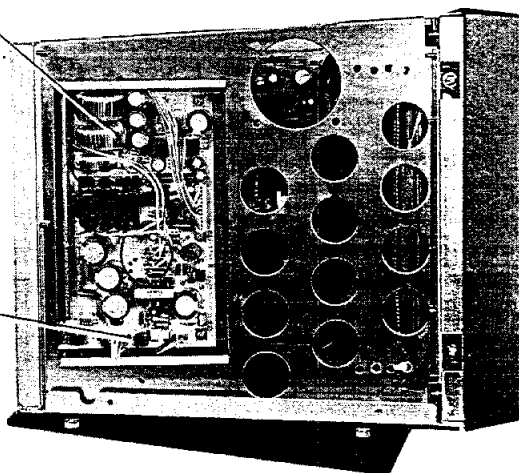

LEFT VIEW

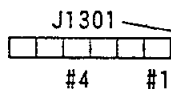

N Photo No.2851

Figure 5-1 Display Unit, Top View and Left Side View

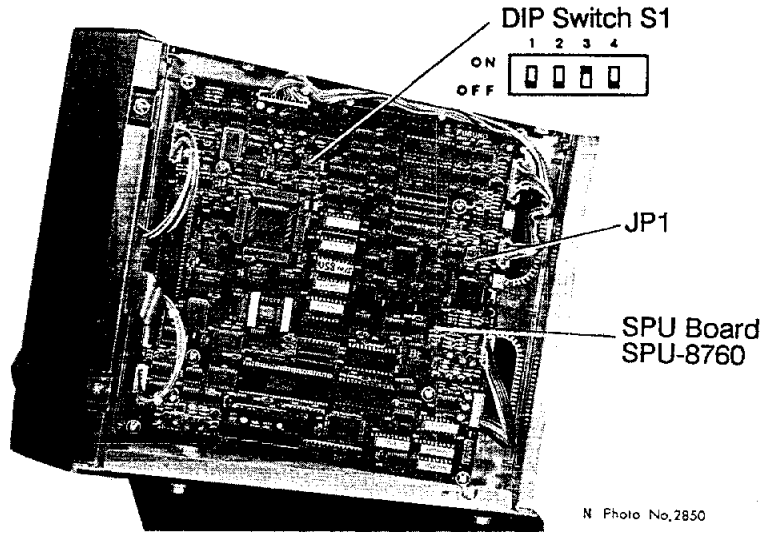

Figure 5-2 Display Unit Right Side View

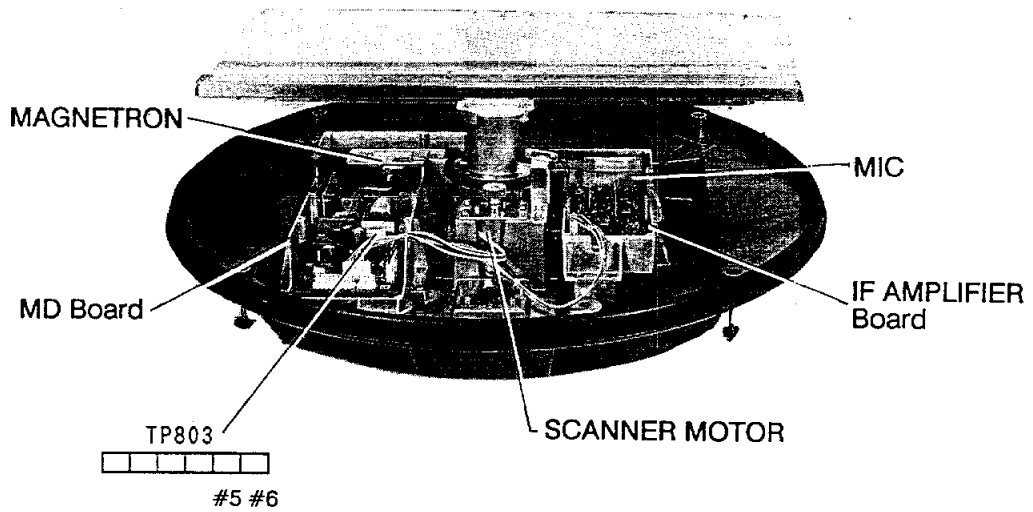

Figure 5-3 Scanner Unit with Cover Removed



---

## 6. INSTALLATION

---

### General Mounting Considerations

---

This radar system is mainly composed of two units: the display unit and the scanner unit.

The scanner unit is designed to withstand the rigors of the marine environment, and if installed properly is thoroughly waterproof. A domed type of scanner unit, where the scanner mechanism is enclosed in a thermoplastic dome, ensures that halyards and other rigging won't get caught in the rotating scanner.

The display unit is carefully constructed to be able to withstand the humidity and corrosive atmosphere common in a pilothouse, but it is not designed to be used outside, exposed to the environment.

If this radar is to be installed on a small boat, the display unit must be mounted inside an enclosed cabinet to prevent corrosion. For maximum protection against corrosion by salt spray, tape the rear connectors and seal them with putty compounds.

The display unit consumes only a moderate amount of power, so there is no need for forced air ventilation. However, it is necessary to provide adequate space behind and around the unit to permit circulation of air and to provide convenient access to the rear connectors.

Even though the picture is quite legible even in bright sunlight, keep the display unit of direct sunlight or at least shaded because of heat that can build up inside the cabinet.

When the radar is first unpacked, check that all necessary units, parts and materials are contained, by referring to the equipment lists. All steel and wood works should be arranged locally.

Installation mainly consists of the following;

- 1) siting and mounting the display unit and scanner unit
- 2) running interconnection cable and power cable
- 3) establishing the ground
- 4) connecting optional equipment
- 5) checking the installation
- 6) adjustments

### NOTICE

*Installation of this equipment requires the use of certain power tools as well as electrical and mechanical skills. If the purchaser has doubts about his or her abilities in these areas, the installation should be performed by a qualified technician.*

---

## Scanner Unit Installation

---

### Siting considerations

The scanner unit is generally installed either on top of the wheelhouse or on the radar mast on an appropriate platform. It should be placed where there is a good all-round view with, as far as possible, no part of the ship's superstructure or rigging intercepting the scanning beam. Any obstruction will cause shadow and blind sectors. A mast for instance, with a diameter considerably less than the width of the scanner, will cause only a small blind sector, but a horizontal spreader or crossrees in the same horizontal plane as the scanner unit would be a much more serious obstruction; you would need to place the scanner unit well above or below it.

It is rarely possible to place the scanner unit where a completely clear view in all direction is available. Thus, you should determine the angular width and relative bearing of any shadow sectors for their influence on the radar at the first opportunity after fitting. (The method of determining shadow and blind sectors is shown later in this chapter.)

The scanner unit should be mounted as high as possible on the boat to ensure best performance at maximum range. In addition, if you have a radio direction finder on your boat, locate its antenna clear of the scanner unit, to prevent interference to the direction finder. A separation of more than two meters is recommended.

The compass safe distance of 3.1 meter (standard compass) and 1.75 meter (steering compass) should be observed to prevent deviation of the magnetic compass.

On a sailboat, the scanner unit is normally mounted on the mast. (An antenna bracket may be optionally supplied to mount it.) On power boats, it is usually installed on a framework above the flying bridge. However, in many cases, you can install it directly on top of the wheelhouse near the ship's centerline.

When this radar is to be installed on larger vessels, consider the following points;

- 1) The interconnection cable run between the scanner and the display is 10 meters long. If additional cable is required for a particular installation, an unbroken length must be used (namely, no splices allowed!), and the maximum length is 30 meters.
- 2) Deposits and fumes from a funnel or other exhaust vent can adversely affect the aerial performance and hot gases tends to distort the radiator portion. The scanner unit must not be mounted where it may be subjected to temperatures in excess of 70°C.

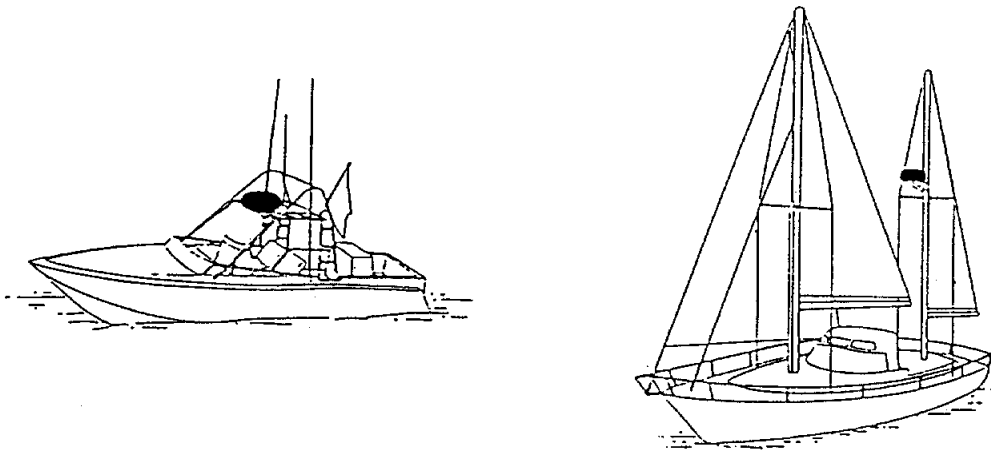

Figure 6-1 Typical Scanner Unit Placement

## Mounting

### Unpacking

1. Open the radome package carefully. Remove the four M10 bolts together with spring and flat washers on the bottom of the radome base assembly. These bolts, spring and flat washers may be discarded, but do not use the bolts in step 4.

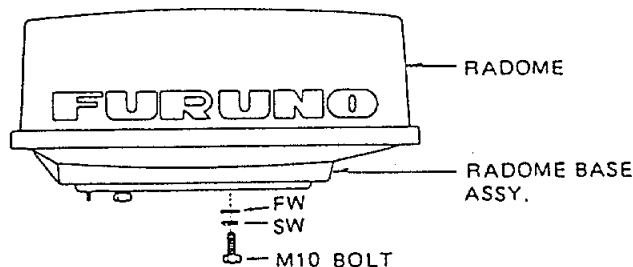

Figure 6-2 Radome, Showing Location of Packing Parts

2. Dismount the radome cover from the mounting base by loosening four fixing bolts. Remove the antenna stoppers to release the radiator.

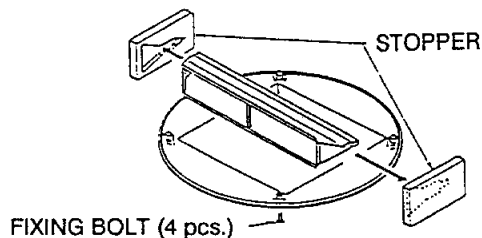

Figure 6-3 Radome with Cover Removed, Showing Location of Stoppers and Fixing Bolts

## Mounting

The mounting surface must be parallel with the ship's waterline and provided with six holes whose dimensions are shown in Figure 6-4: Four 12 mm (1/2") holes for fixing, one 27 mm (1.1") hole for the cable entry, and one 20 mm (3/4") hole for the vent tube.

There is a vent tube on the base of the scanner unit which should face the stern direction. The unit is adjusted so that a target echo returned from the bow direction will be shown on the 0 degree (heading marker) position on the screen. When drilling holes, take care that the holes are parallel with the fore and aft line.

In very hot and humid climates, moisture may condense inside the radome, causing corrosion. To prevent this, the vent tube is fitted. This tube allows the radome to "breathe" while not allowing entry of water from outside into the radome. Therefore, make sure the tube is kept free of foreign materials and is not pinched or kinked. The vent tube extends downward by 27 mm (1.1") from the radome base. Ensure the vent tube extends downward before installing the radome. See Figure 6-5.

3. Prepare a platform of 5-10 mm in thickness for the scanner unit. Find the vent tube on the radome base. Next, position the radome base so the vent tube faces the stern direction. This alignment must be as accurate as possible.

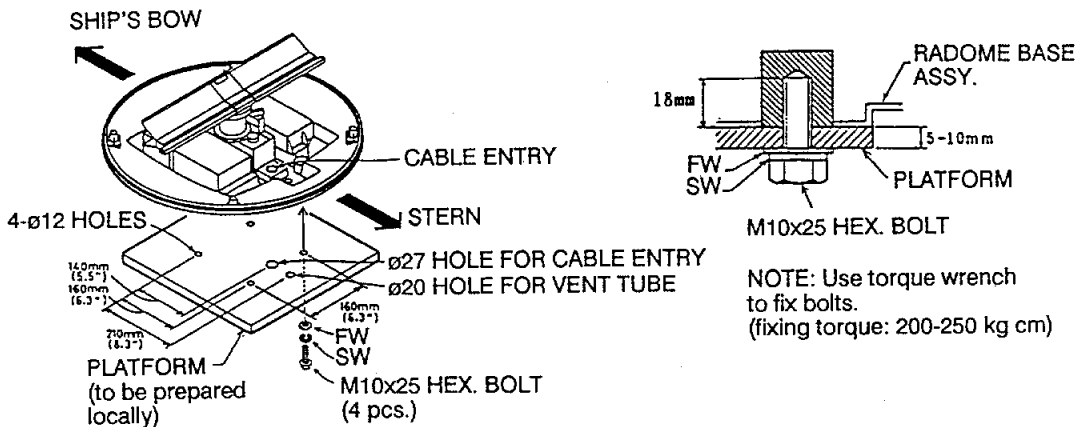

Figure 6-4 Fixing the Radome to a Platform

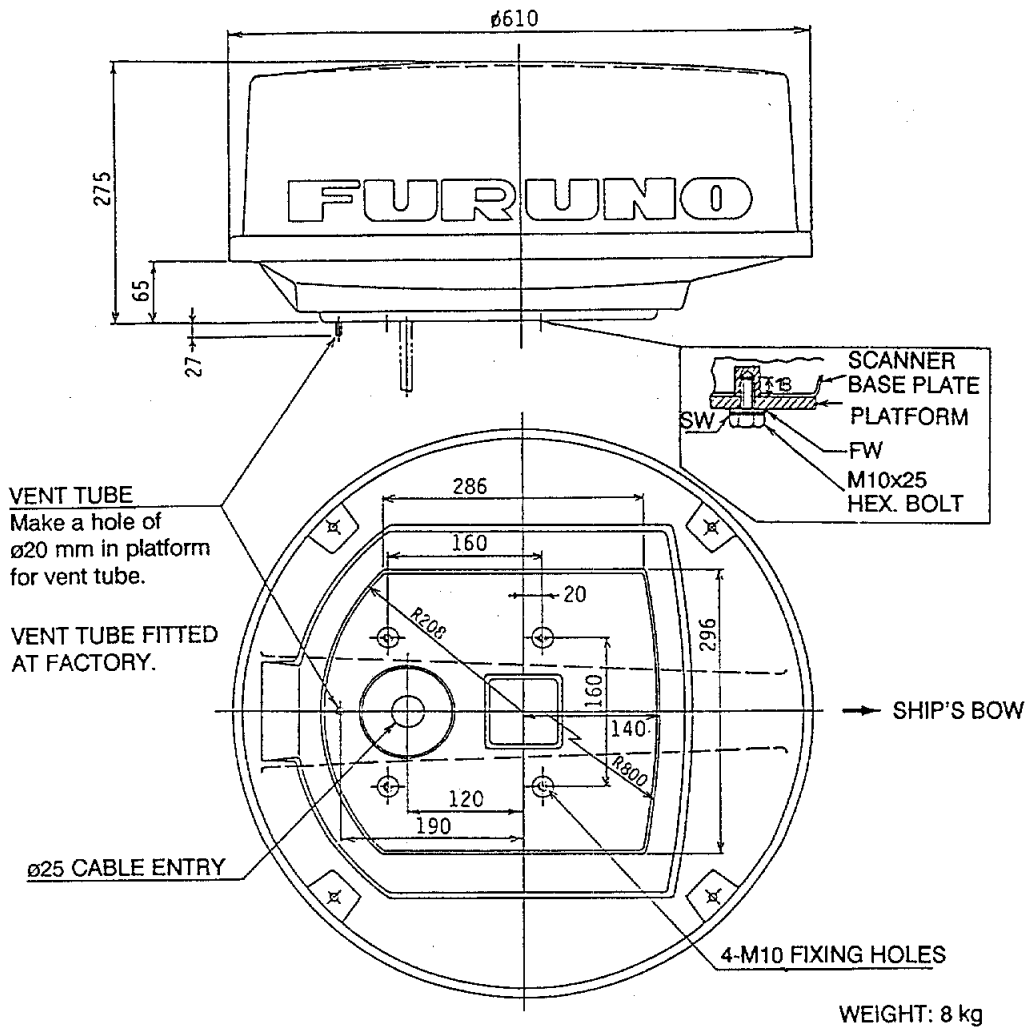
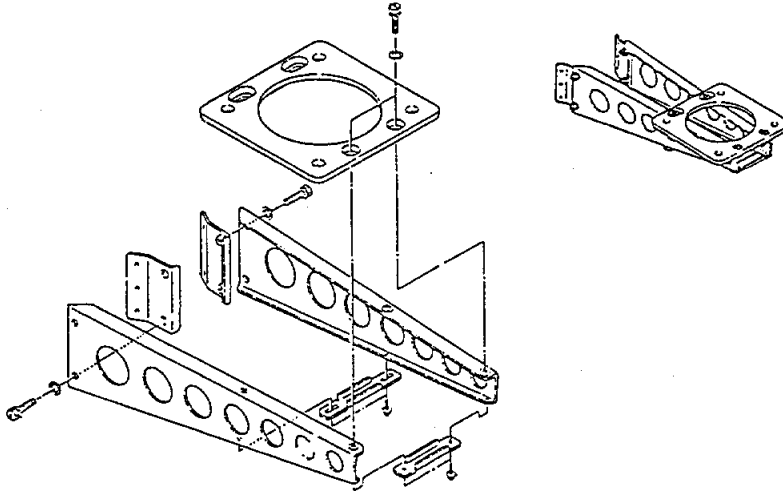
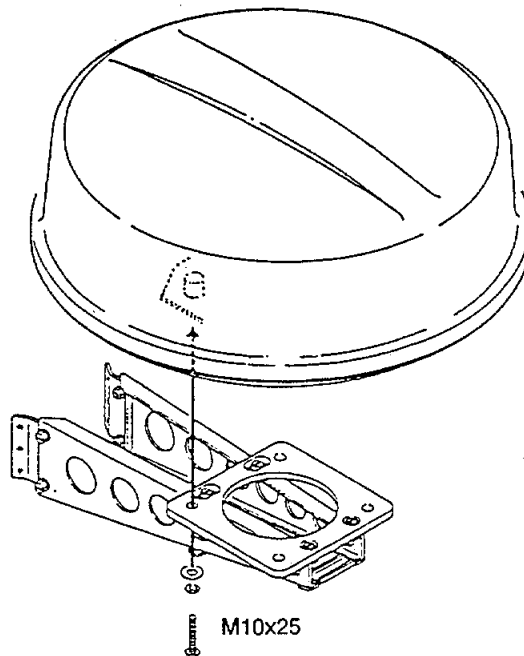

Figure 6-5 Scanner Unit Outline Drawing

4. Make sure the vent tube is in the correct position; then fix the radome base to the mounting surface with the four M10x25 hex bolts, flat and spring washers (supplied).

**Optional Antenna Bracket Installation for Sailboat****(A) Assembling the Antenna Bracket****(B) Mounting Radome To Mounting Bracket****Figure 6-6 Optional Antenna Bracket**

## Wiring and final preparation of scanner unit

1. Drill a hole of at least 20 mm diameter through the deck or bulkhead to run the interconnection cable between the scanner unit and display unit. Pass the cable through the hole; then seal the hole with sealing compound for waterproofing.

In order to minimize the chance of picking up electrical interference, avoid where possible routing the interconnection cable near other onboard electrical equipment. Also avoid running the cable in parallel with power cables.

2. Remove the cable clamping plate by loosening four M4 screws and two gaskets at the radome base. See Figure 6-7.
3. Pass the cable through the hole at the bottom of the radome base. The interconnection cable has three plugs which you connect inside the scanner unit.

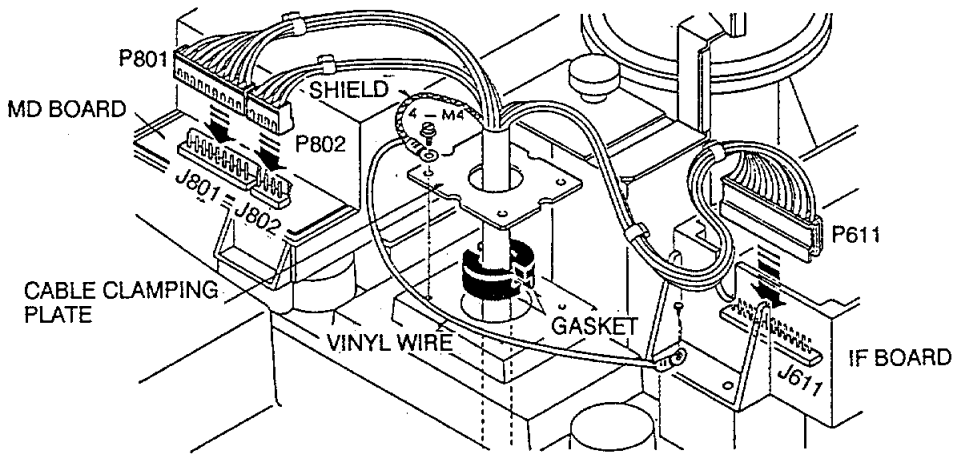

Figure 6-7 Cable Connections and Grounding

4. Secure the cable with the cable clamping plate and gaskets. Ground the shield and vinyl cables by using one of the fixing screws for the cable clamping plate and for the IF amplifier chassis. See Figure 6-7.
5. Mate plugs P801 (9 way) and P802 (4 way) to the MD Board. Remove the lid of the IF Board and mate the 14-way plug (P611) to the board. Replace the lid, being careful not to pinch the wires on the lid.

- Put the radome on the radome base assembly, orienting the narrower recessed part in the direction of the bow. See Figure 6-8.

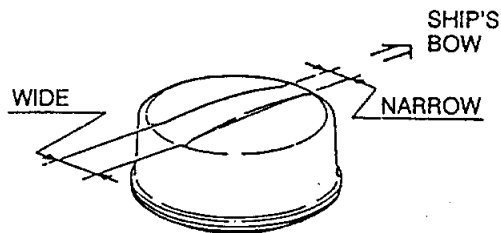

Figure 6-8 Radome Cover Placement

- Tighten the radome fixing bolts temporarily, because the radome may have to be opened again for adjustment after installation.
- The cable run must be properly supported, and must not be used to provide impromptu foot-holds or hand-holds!! Clips or hangers should be employed every nine inches.



## Display Unit Installation

The display unit can be mounted on a tabletop, a bulkhead or on the overhead. Install it where it can be viewed and operated conveniently, but where it is protected from being sprayed or immersed in salt or fresh water.

**Compass Safe Distance:** The magnetic compass may be affected if the display unit is placed too close to it, because of the magnetic fields generated in the radar. The compass safe distance is approximately 0.87 meters for the standard compass and approximately 0.65 meters for the steering compass.

The display unit should be oriented so that you can view the screen while facing towards the bow. This will make determination of your position easier.

The drawing below gives the mounting dimensions for this radar. Although the unit is light-weight (10 kilograms), reinforce the mounting place, if necessary.

Make sure you allow enough clearance to get to the connectors behind the unit. Make sure you leave at least a foot or so of "service loop" of cables behind the unit so that it can be pulled forward for servicing or easy removal of the connectors.

### Tabletop mounting

1. Loosen the two M8x40 bolts at the front of the display unit. Take out the fixing plate.
2. Using the fixing plate as a template, mark screw locations in the tabletop. Drill four holes of 12 mm diameter in the tabletop.
3. Secure the fixing plate to the tabletop with M10 bolts, nuts and washers.
4. Lay the display unit on the fixing plate. Secure it with the two M8x40 bolts loosened in step 1. Cover the bolts with the two caps (supplied).

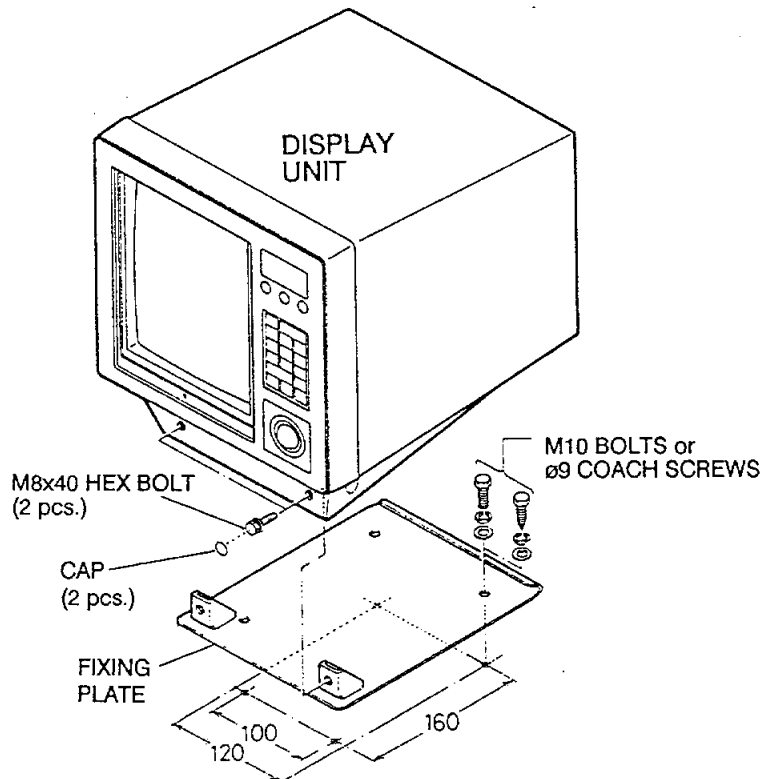

Figure 6-9 Tabletop Mounting

**Bulkhead or overhead mounting**

1. Referring to Figure 6-10, change the location of the fixing plate, mounting base, bottom plate and cover.

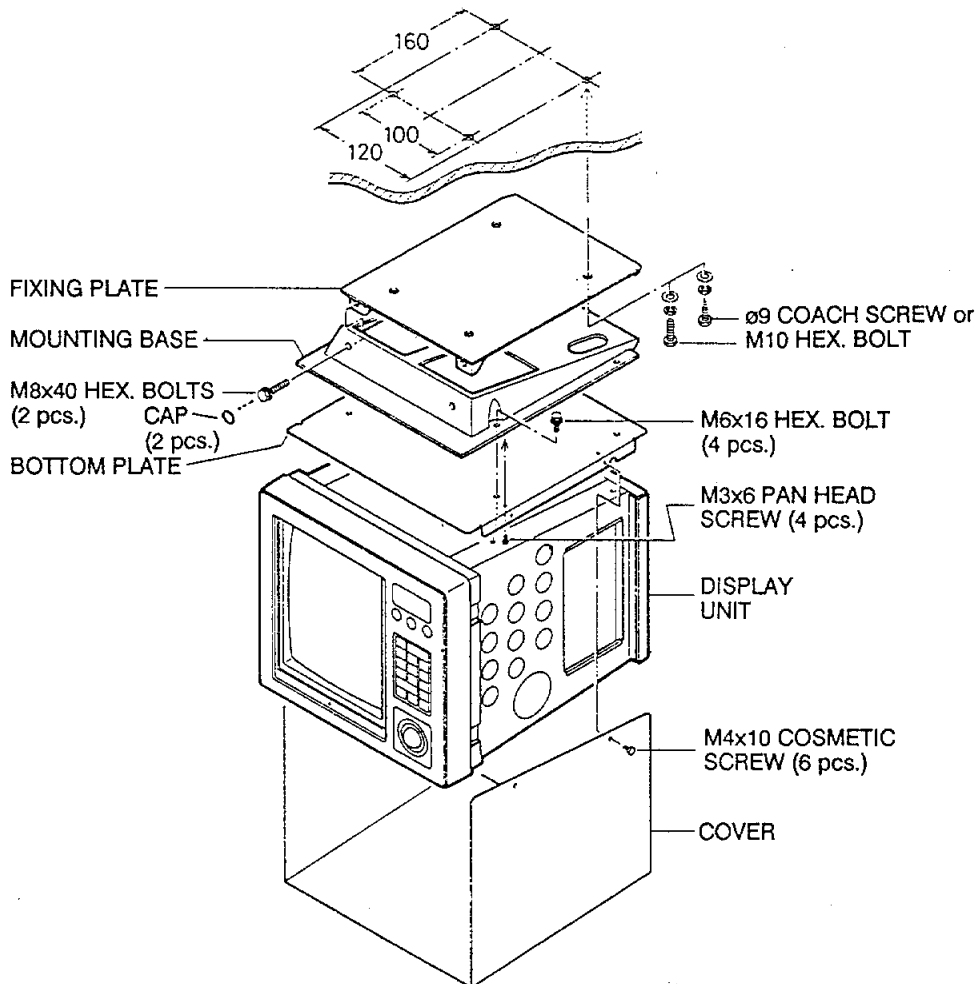

Figure 6-10 Display Unit Bulkhead or Overhead Mounting

Now comes the wiring part. For general wiring diagram, see page 6-13.

**Antenna connection**

Connect the interconnection (multicore) cable from the scanner unit at the back of the display unit.

## Power connection

This radar is designed for 12, 24 or 32 volt battery systems. Internal wiring and fuse changes are needed for 12 VDC input voltage if voltage requirement is not specified when ordering. A piece of gear of this quality deserves to have a circuit breaker dedicated to it alone. The size of the wire feeding power to the unit should be no less than AWG #14 (2.0 mm square.) Refer to the figure below for how to assemble the power connector (supplied).

1. Remove the vinyl sheath by 35 mm, taking care not to nick the shielding mesh. Then, slide the mesh back.
2. Remove the inner sheath by 10 mm.
3. Remove the insulation of lead wires by 3 mm.
4. Slide connector's housing over the cable.
5. Solder the lead wires to the connector, taking note of the polarity. Wrap the shield with tape or vinyl tube to prevent short circuiting.
  - #1: + (white)
  - #2: - (black)
  - #3: shielding mesh
6. Assemble the connector and tighten the set screw.
7. Clamp the connector and tape the exposed shielding mesh.

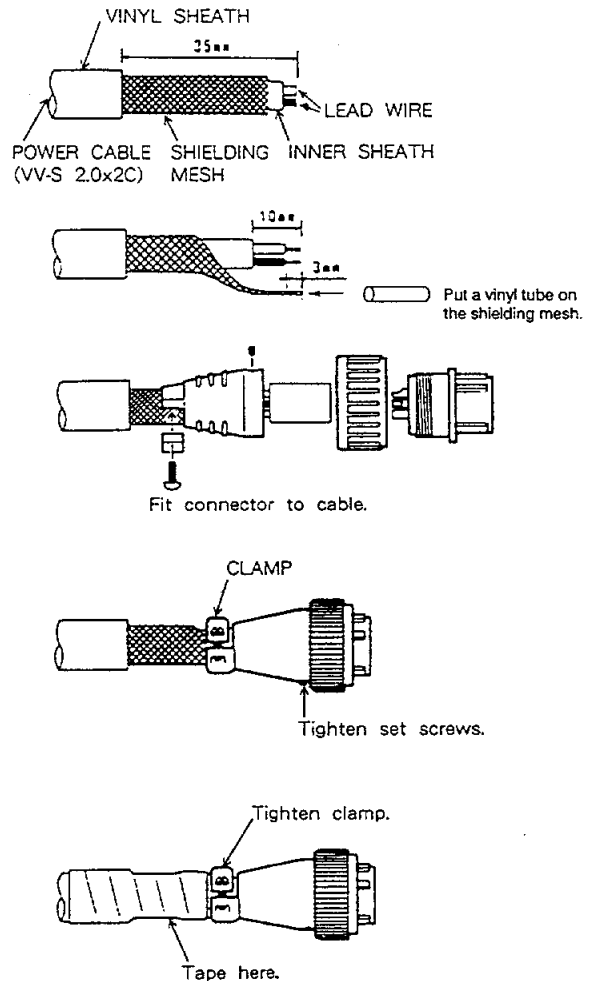

Figure 6-11  
Fabrication of the Power Cable Connector

## Ground connection

Run heavy duty ground wire from the grounding terminal at the rear panel of the display unit to the nearest grounding point on the boat. Consult with a qualified electrician if you are uncertain of where the proper grounding points on your vessel are.

## Gyrocompass (or heading sensor) connection (option)

If an AC synchro or DC step type gyrocompass is installed on your boat, the true bearing of your ship's heading, of the cursor, and of the EBL (Electronic Bearing Line) may be displayed on the display.

A cable assy (22S0269-0) fabricated with a connector and an A-D Converter (AD-100) are optionally supplied. Remove the GYRO jack cap on the rear panel to expose the GYRO jack. Mate the connector with this jack. Fabrication of the other end of the cable and connection to the A-D Converter are explained in the Operator's Manual for the AD-100 (Publication No. OM-E4340.)

Open the cover of the display unit and turn OFF DIP switch S1 #3 on the SPU board. (Refer to Figure 5-2 on page 5-6.) "GYRO" appears at the top of the screen.

The heading sensor (FLUX-50, C-2000) having AD-10S format or NMEA 0183 output data format can be connected instead of gyrocompass. In this case, DIP switch S1 #3 should be ON (factory setting is "ON"), to show "MAG" indication.

## External navigational receiver connection (option)

If your navigation receiver has NMEA 0183 or FURUNO CIF data format, your own ship's position in latitude/longitude, speed and the range/bearing to waypoint may be sent to this radar, and be seen in the bottom text area.

An NMEA cable fabricated with a connector is optionally supplied. Remove the NMEA jack cap on the rear panel to expose the NMEA jack. Mate the connector with this jack. Fabrication of the other end of the connection cable should be left to a competent service technician, because it is difficult to find the point to be connected.

### For service technicians;

J1352#1,#2: No connection  
J1352#3: RD-Hot  
J1352#4: RD-Cold

The figure on the next page gives detailed wiring information.

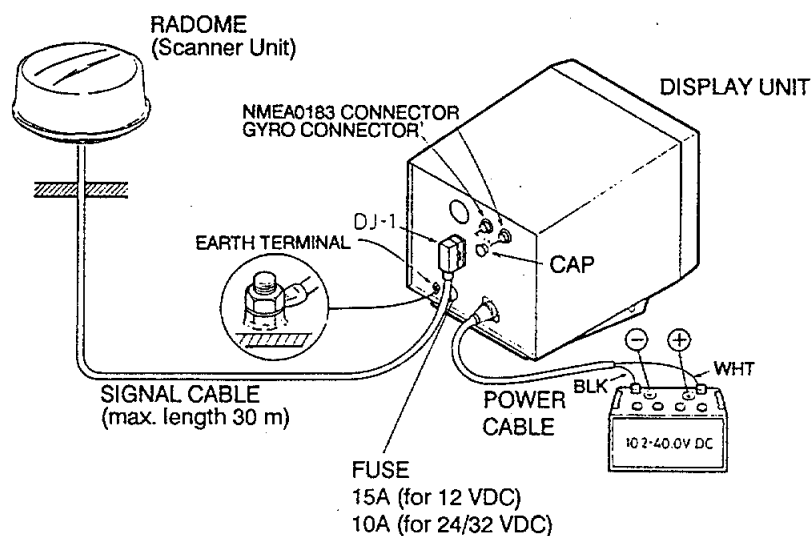

Figure 6-12 Detailed Wiring Diagram

## Checking the Installation

After installing the unit check it for proper installation by using the checklist below.

Table 6-1 Installation Checklist

Tick here.

- The vent tube on the radome base is on the side of the stern direction correctly.
- Four radome fixing bolts are fully tightened.
- The connection cable is waterproof at the scanner base.
- The cable is securely retained against the mast or mounting and is free of interference from running rigging.
- Check that the cable gland or entry on the deck is waterproof, if provided.
- The power connections to the battery are of correct polarity.
- Check that the plugs at the rear of the display are inserted correctly and are secure.
- Check that the fuse at the rear of the display is 15A for 12 VDC or 10A for 24/32 VDC.
- If the input voltage is changed from 24/32 VDC to 12 VDC in the field, wirings on the p.c. board must be changed. Refer to the attached sheets.

---

## Adjustments

---

After checking the unit for proper installation its time to adjust it.

*To prevent possible personnel injury from radio frequency (RF) radiation hazards, be certain that no one is near the scanner before turning on the radar.*

*Tuning and calibration of this equipment requires experience and specific technical skills. Thus this work should be performed by a qualified service technician.*

### Initial procedures

1. Press the **POWER/OFF** touchpad on the display unit, and the control panel will light up. In approximately 2 minutes and 30 seconds, the message "ST-BY" will appear at center of the screen. While this warmup is in process, set the **GAIN** control at 2 o'clock, and the **A/C RAIN** and **A/C SEA** controls at fully counterclockwise.
2. When "ST-BY" appears press the **TX/OFF** touchpad. The radar will start transmitting on the 3 mile range, and you will probably see some targets around you, even though the gain, tuning and other adjustments have yet to be optimized.
3. Bring up the **GAIN** control until a small amount of noise appears on the screen.
4. Adjust the **GAIN** control on the front panel, for a little background noise showing on the screen, and then hit the **RANGE -** touchpad several times to bring you down to the 0.25 mile range. Without disturbing the front panel **GAIN** control, adjust the **A/C SEA** control until nearby radar targets are clearly shown on the screen. Too much **A/C SEA** action will eliminate small targets, and too little **A/C SEA** action will cause the screen to be so full of targets and noise that it is hard to determine which target is which as compared to visual sightings. Note that adjusting the **GAIN** and **A/C SEA** controls in this manner (**GAIN** at long range, **A/C SEA** at short range) will equalize the picture at all ranges, and you will not have to jockey back and forth with the **GAIN** control especially when you change range scales.

### Sweep timing

This adjustment ensures proper radar performance, especially on short ranges. The radar measures the time required for a transmitted echo to travel to the target and return to the source. The received echo appears on the CRT based on this time. Thus, at the instant the transmitter is fired, the "Sweep" should start from the center of the CRT (sometimes called sweep origin.)

A "trigger" pulse generated in the display unit goes to the scanner unit through the interconnection cable to trigger the transmitter (magnetron.) The time taken by the signal to travel up to the scanner unit varies, depending largely on the length of interconnection cable. During this period the display unit should wait before starting the sweep. When the display unit is not adjusted correctly, the echoes from a straight local object (for example, a harbor wall or straight pier) will not appear with straight edges—namely, they will be seen as "pushed out" or "pulled in" near the picture center. The range of objects will also be incorrectly shown.

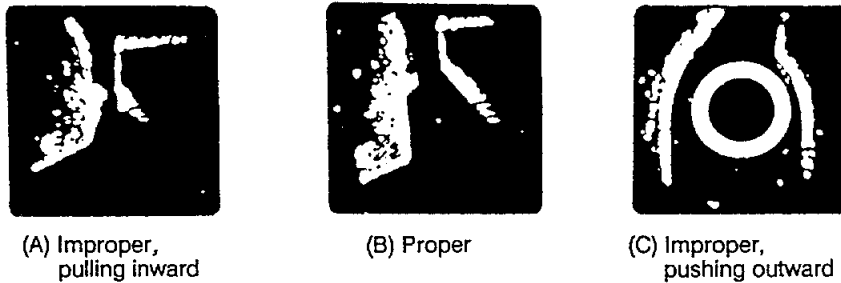

Figure 6-13 Examples of Improper and Correct Sweep Timings

1. Transmit the radar on the 0.25 mile range and adjust the **GAIN** and **A/C SEA** controls.
2. Visually select a straight echo (harbor wall, straight pier).
3. Press the **FUNCTION** touchpad (about 5–6 seconds) until the **INSTALLATION** menu appears.

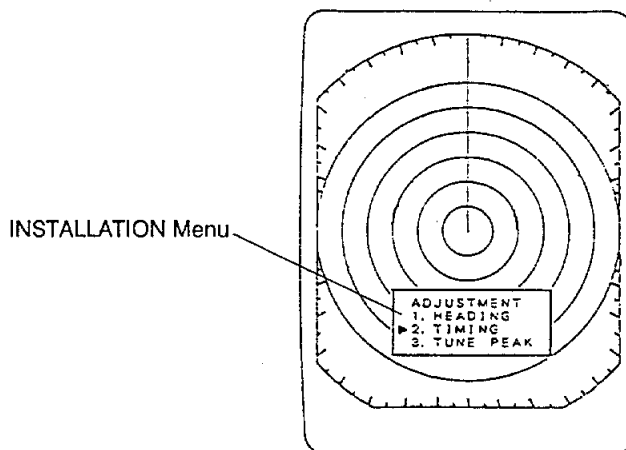

Figure 6-14 INSTALLATION Menu

4. With either **RANGE** touchpad, select **TIMING**.
5. Press the **FUNCTION** touchpad. Only the indication **TIMING** appears.
6. While looking at the echo selected at step 2, press the **RANGE +** touchpad if the target is pulled inward, or press the **RANGE -** touchpad if the target is pushed outward.
7. Press the **FUNCTION** touchpad to complete the adjustment.

## Auto tuning

This unit tunes itself automatically each time the power is turned on, thus there is no tuning control on the front panel. Adjust the tuning circuit as follows to get the best tuning point. This adjustment is also needed when the magnetron is replaced.

1. Turn on the radar and transmit it on the 24 mile range. Wait (about ten minutes) until the magnetron stabilizes.
2. Take off the VR compartment cover. Set the **TUNE** switch to **MANUAL**. The **AUTO** indication is replaced by "MAN."

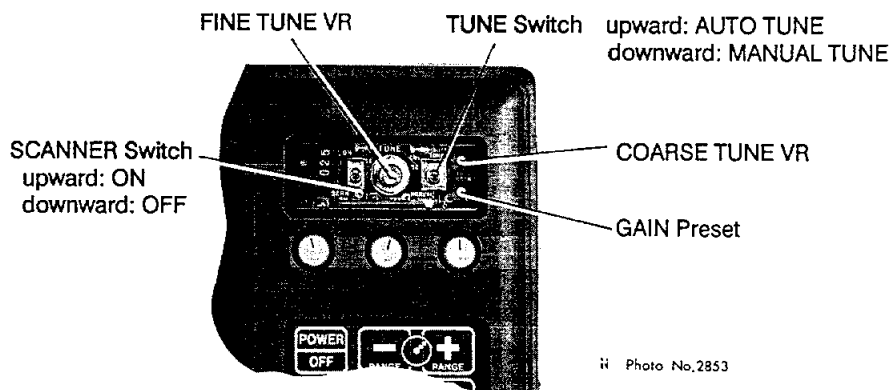

Figure 6-15 Controls in the VR Compartment

3. Adjust both the coarse and fine **TUNE** potentiometers so a long range target echo is displayed with maximum sensitivity. (Note that the tuning bar is not an indicator of tuning at this time; please disregard it.)
4. Press and hold down the **FUNCTION** touchpad until the **INSTALLATION** menu appears.
5. With either **RANGE** touchpad, select **TUNE PEAK**.
6. Press the **FUNCTION** touchpad to start automatic tuning. Only **TUNE PEAK** appears during tuning.
7. Upon completion of tuning (about 5 seconds) **TUNE PEAK** is replaced by **PEAK OK**. Then, about 15 seconds later, **PEAK OK** disappears from the display.
8. Return the **TUNE** switch to the **AUTO** position.



## Relative bearing alignment

You have mounted the scanner unit facing straight ahead in the direction of the bow. Therefore, a small but conspicuous target dead ahead visually should appear on the heading mark (Zero degree).

In practice, you will probably observe some small error on the display for most installations because of the difficulty in achieving accurate initial positioning of the scanner unit. The following adjustment will compensate for this error.

If you don't know how to do it *well*, it's best you leave this part to a qualified technician. (Remember that the radome fixing bolts remain untightened. They should now be secured if the following alignment is not necessary.)

1. Identify a suitable target (for example, ship or buoy) at a range between 1/8 to 1/4 miles, preferably near the heading mark. To minimize error, keep echoes in the outer half of the picture by changing the range.
2. Measure the bearing to the target by operating the trackball. The bearing is shown at the bottom center of the screen.
3. Using a compass card, visually find the relative bearing to the target.
4. Compare the bearing measured in step 2 and 3 above and calculate the direction and magnitude of the bearing error. If the error is within 30 degrees go to step 9, to correct the error at the display unit. If the error is greater than 30 degrees first make initial adjustments at the scanner unit and then fine tune at the display unit.

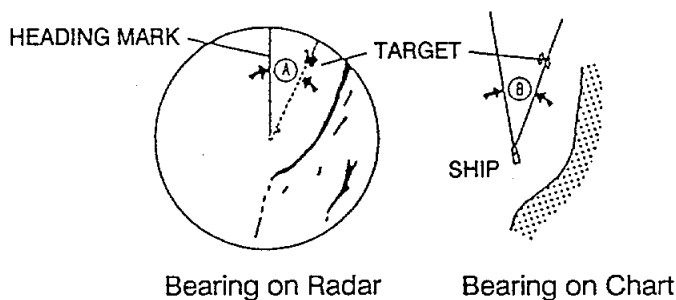

Figure 6-16 Calculating Bearing Error

5. Open the radome and **slightly** loosen the two screws which secure the heading mark key mounting plate. (See Figure 6-18.) Overloosening makes fine adjustment difficult.
6. Adjust the position of the heading mark key, moving to the aft (or fore) direction if the bearing A is greater (or smaller) than bearing B, respectively. *Note that it is necessary to correct the error only so it is within 30 degrees.*

7. Tighten the fixing screws.
8. Close the radome cover on the radome base assembly, being careful of its direction. The narrower recessed portion should face the bow direction.
9. Press and hold down the **FUNCTION** touchpad until the **INSTALLATION** menu appears.
10. With either **RANGE** touchpad, select **HEADING**. The indications **HEADING** and  $0.0^\circ$  appear.

11. Press the **FUNCTION** touchpad. The tuning range markers (white) appear. See Figure 6-17(a).

12. Identify a suitable target (for example, ship or buoy) at a range between  $1/8$  to  $1/4$  miles, preferably near the heading mark. To minimize error, keep echoes in the outer half of the picture by changing the range.

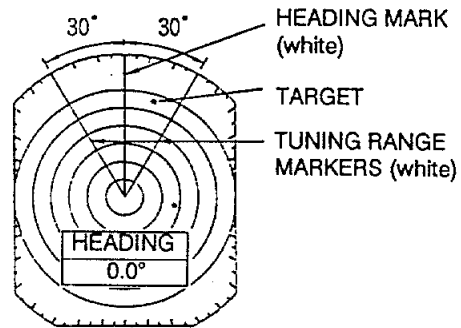

(a)

13. Operate a **RANGE** touchpad, and a light-blue heading marker appears. Press a **RANGE** touchpad to bisect the target with the light-blue heading marker. See Figure 6-17(b).

14. To complete the adjustment, press the **FUNCTION** touchpad.

15. As a final test, move the boat towards a small buoy and confirm that the buoy shows up dead ahead on the radar when it is visually dead ahead.

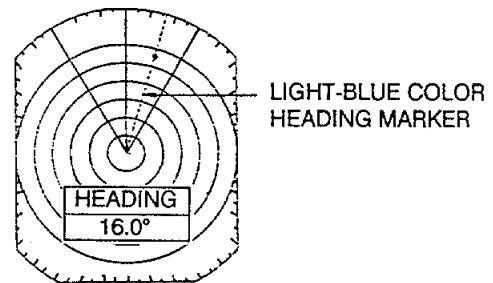

(b)

Figure 6-17  
Display During Heading Adjustment

## Preset gain

Preset gain is preadjusted at the factory. However if the receiver gain is too high or low, readjust it, with the GAIN VR in the VR compartment.

1. Set the controls as follows;

**RANGE:** max. range; **GAIN:** fully clockwise; **A/C SEA** and **A/C RAIN:** fully counterclockwise; **FTC:** off; **ECHO STRETCH:** off; **PLOT/DIM:** plot off; **ZOOM/BRILL:** zoom off, and **IR:** on.

2. Open the VR compartment. Set the GAIN VR where a little background noise appears on the screen. For the location of the GAIN VR, see Figure 6-15.

3. Turn the IR circuit off. Confirm that noise increases.

## Magnetron heater voltage

Magnetron heater voltage is formed at the MD Board of the scanner unit and preadjusted at the factory. Therefore no adjustment is required even though the cable length between the display unit and the scanner unit is changed. However, verify heater voltage by the following.

1. Suspend scanner rotation by turning off the **SCANNER** switch in the VR compartment. For the location of the switch, see Figure 6-15.
2. Connect a multimeter, set to 10 VDC range, between #4(+) and #6(-) of test point TP803 on the MD Board.
3. Confirm that the multimeter shows  $7.5\text{ V} \pm 0.1\text{ V}$ . If not, adjust potentiometer VR801 on the MD Board.

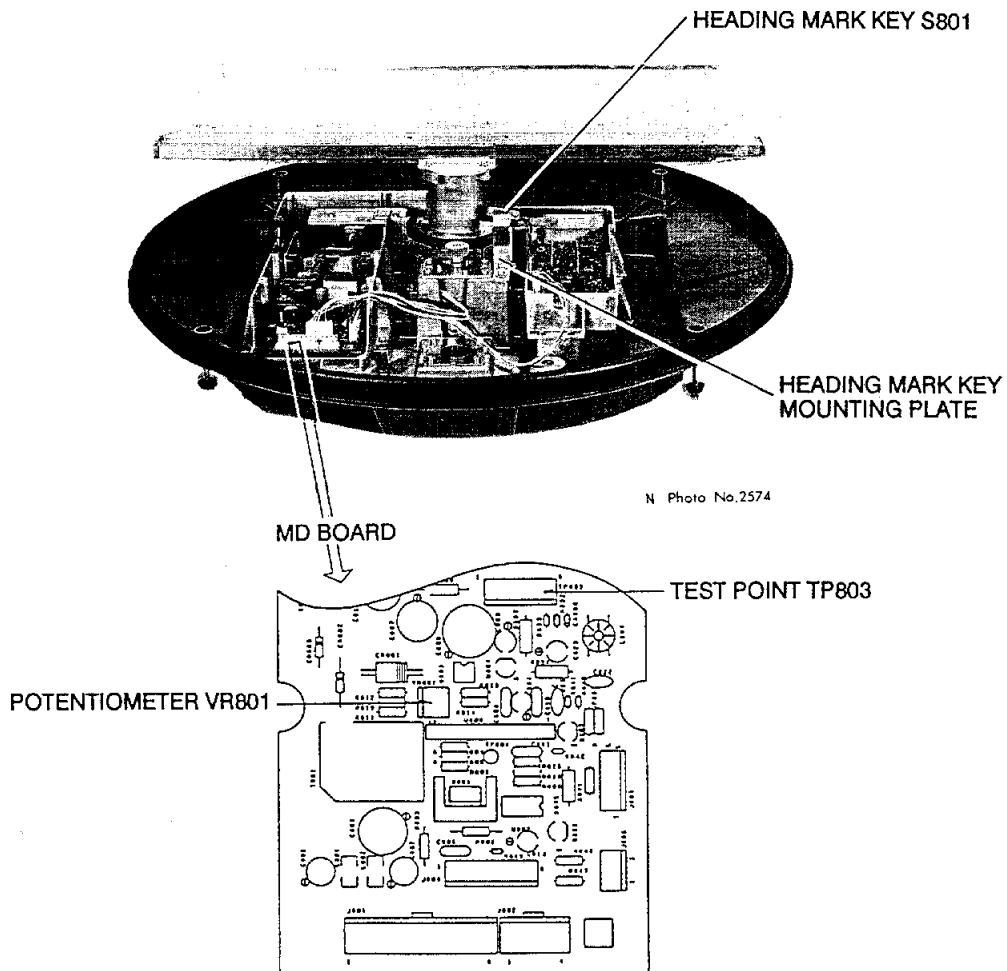

Figure 6-18 Scanner Unit with P. C. Board Covers Removed

---

## Measurement of Blind Shadow Sectors

---

In some shadow sectors, it should be remembered that there may not be sufficient intensity to obtain an echo from very small targets even at close range, despite the fact that a large vessel may be detected at a much greater range in non-shadowed sectors. For these reasons the angular width and relative bearing of any shadow sectors should be determined. This section describes how to do this. In the case of a new vessel this should be done during sea trials. In other ships it should be done at the first opportunity after fitting a new radar set.

It should be understood that even a small shadow sector can hide another vessel if it is on a collision course. The bearing will remain constant in the shadow area and the approach of the other vessel may remain undetected until it is too late to avoid a dangerous situation.

There are two methods of determining the angular width of a shadow sector:

- 1) Turn the boat *very slowly* through 360 degrees while a small but clearly defined target is observed at a distance of a mile or so. (Do not use a buoy with a reflector as this target is too powerful to achieve the required result.)

If the echo disappears while the boat is turning, the target has entered a shadow sector and it will again become visible when the target emerges from the shadow. Very quiet conditions of wind and sea are essential to ensure reliable results when this operation is carried out on a small craft since a rough sea can cause a buoy to be lost in the clutter or to be temporarily submerged or hidden by waves. An unsteady movement may cause the boat to swing through a shadow sector before the scanner has completed one revolution. In any case an average of several observations of each shadow sector should be taken. It is a waste of time to attempt the operation in anything other than very smooth water with little wind.

- 2) Another method is to observe the shadow sector against a background of sea clutter. Any shadows will show as dark sectors in the clutter. See Figure 6-19.

Note that a shadow cannot be fairly estimated in heavy clutter, as echoes from either side of the sector may be spread into it and give an illusion that objects in the sector are being observed. Nor can it be satisfactorily determined in confined waters, because of the probability of indirect, false or multiple echoes being produced from nearby buildings or other vessels.



Shadow caused by mast

Figure 6-19 Appearance of a Shadow Sector on the Display Screen

The result of the above measurement should be recorded on a blind shadow sector diagram. Figure 6-21 is an example of a shadow sector diagram for the scanner unit sited as in Figure 6-20. The blind shadow sector diagram should be fixed near the display unit.

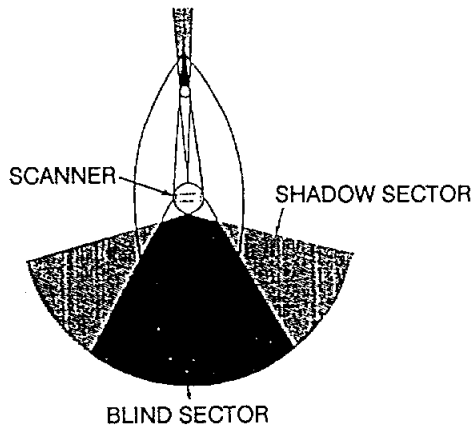

Figure 6-20 Shadows Caused by Objects

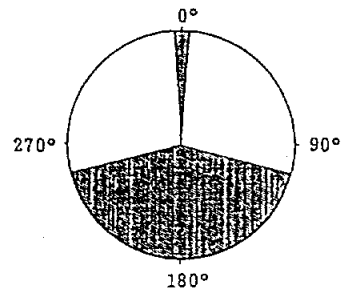
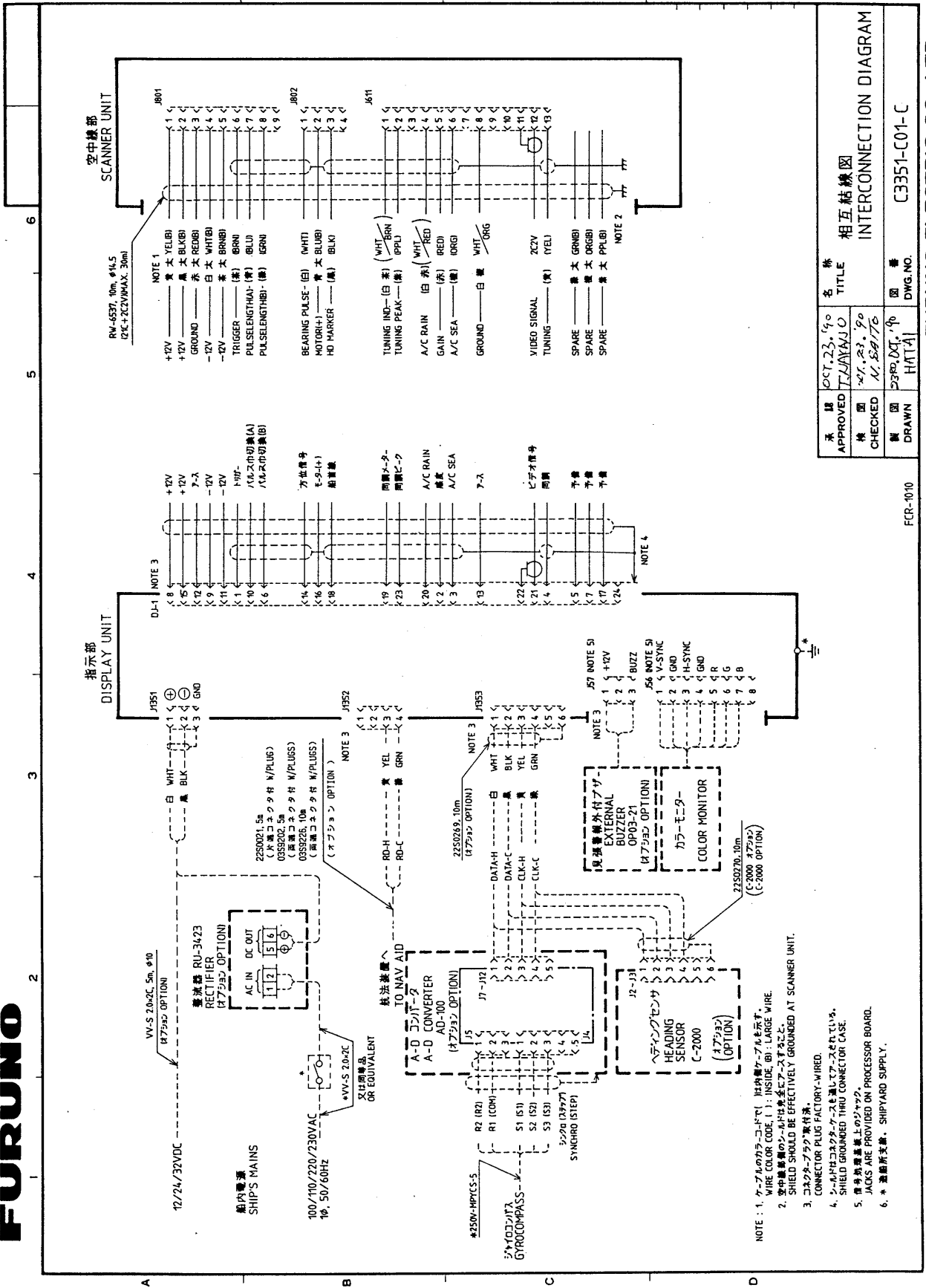

Figure 6-21 Shadow Sector Diagram



承認 APPROVED	承認者 T. YAMAJI	名 称 TITLE	相 互 結 線 図 INTERCONNECTION DIAGRAM
検 査 CHECKED	検 査 者 M. S. S. ITO	製 図 DRAWN	製 図 番 号 DWG. NO.
製 図 日 DATE	製 図 年 月 日 YEAR, MONTH, DAY		

FCR-1010

FURUNO ELECTRIC CO., LTD.

C3351-C01-C

- NOTE: 1. ケーブルの色は、ケーブルの色で示す。 (CABLE COLOR CODE IS SHOWN BY CABLE COLOR.)
2. 空中線部のシールドは必ずアースすること。 (SHIELD SHOULD BE EFFECTIVELY GROUND AT SCANNER UNIT.)
3. コネクターは必ず標準品を使用すること。 (CONNECTOR PLUG FACTORY-WIRED.)
4. シールドケーブルは必ずシールド処理を施すこと。 (SHIELD CABLE SHOULD BE SHIELDED THROUGH CONNECTOR CASE.)
5. 舟内装置は必ず電源板上に設置すること。 (EQUIPMENT SHOULD BE PROVIDED ON PROCESSOR BOARD.)
6. \* 造船所直営、SHIPYARD SUPPLY.

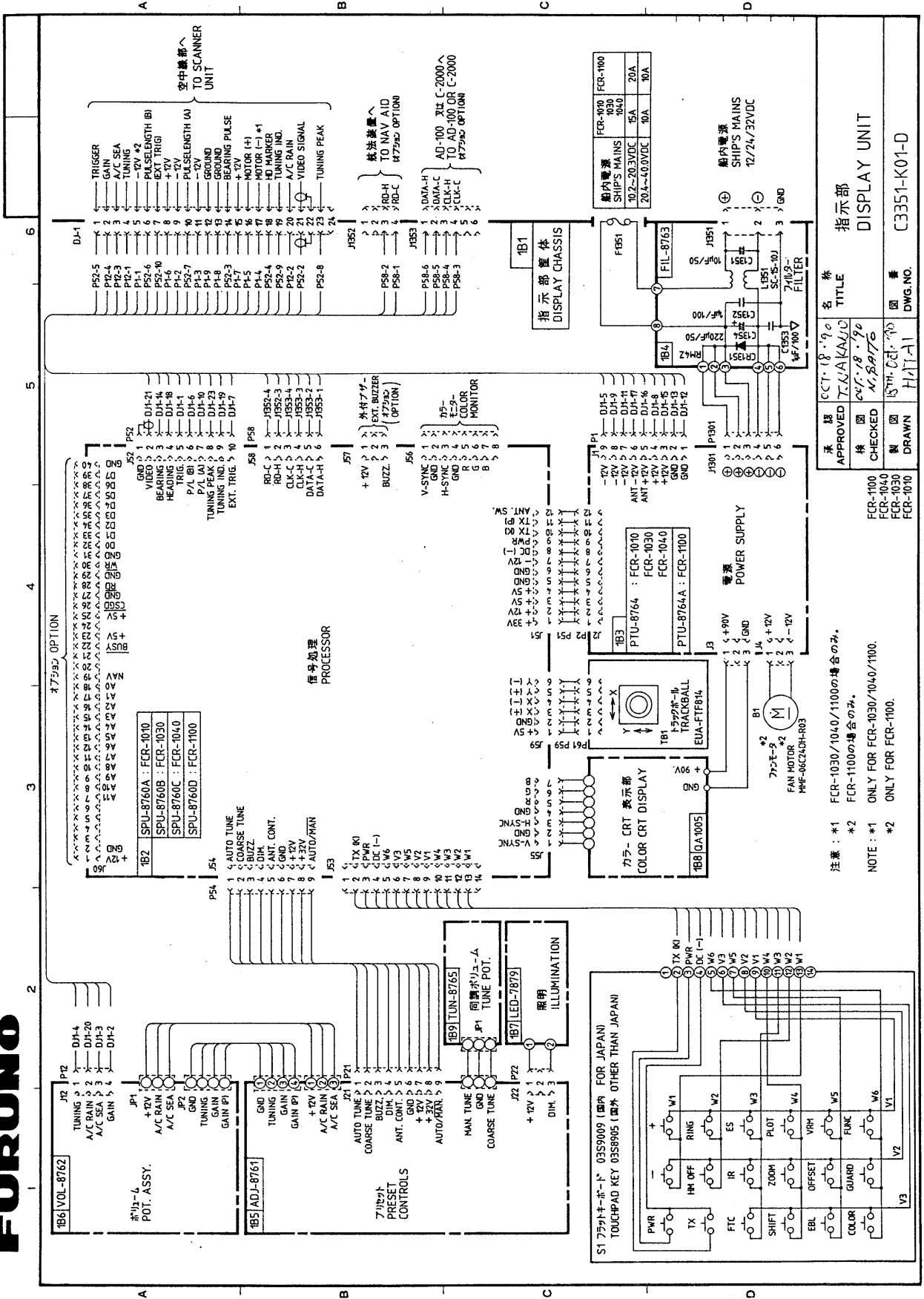

承認	CCCT. 18.9.0	名称	指示部
APPROVED	T. A. KAWAUCHI	TITLE	DISPLAY UNIT
検閲	2018-90	製国	JAPAN
CHECKED	M. SATO	製図	15TH. CCCT. 70
製図	15TH. CCCT. 70	図番	C3351-K01-D
DRAWN	H. ITO	DWG. NO.	

注: \*1 FCR-1030/1040/1100の場合のみ。  
 \*2 FCR-1100の場合のみ。  
 NOTE: \*1 ONLY FOR FCR-1030/1040/1100.  
 \*2 ONLY FOR FCR-1100.

FURUNO ELECTRIC CO., LTD.



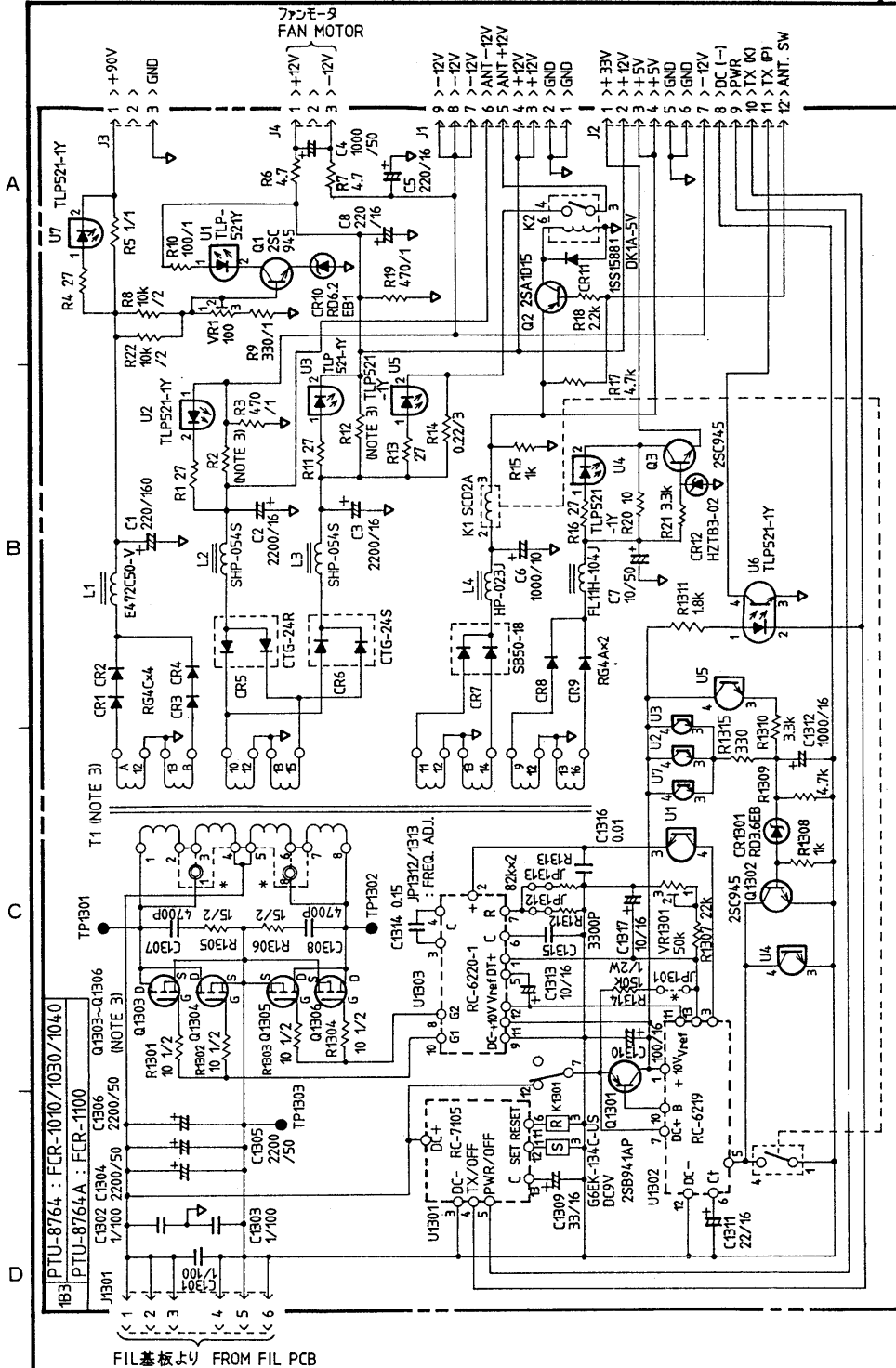

NOTE 2. 特記なき抵抗の単位は全てΩ, 0.25W,  
又コンデンサはμF.

ALL RESISTANCE IN OHMS, 0.25W, CAPACITANCE IN  
MICRO FARADS UNLESS NOTED OTHERWISE.

MODEL	T1	R2/R12	α1903-1906
FCR-1010/1030/1040	RT-8912	0.56/1	25K1266
FCR-1100	RT-8926	0.22/3	25K798 (1)

NOTE 3.

NOTE 1. \* : 電源電圧に従って接続を変える。  
\* : CHANGE CONNECTIONS WITH SHIP'S MAINS VOLTAGE.

船内電源 SHIP'S MAINS	T1の入り側接続 PRIMARY CONNECTION OF T1	JP1301
24/32VDC	②-③, ⑥-⑦	OPEN
12VDC	①-③, ②-④, ⑥-⑧, ⑤-⑦	SHORT

FCR-1010/1030/1040/1100	品番 ITEM	品名 NAME	材質 MATERIAL	数量 Q'TY	図番 DWG. NO.	備考 REMARKS
-------------------------	------------	------------	----------------	------------	----------------	---------------

承認 APPROVED	DEC. 27 '90 T. KAWA	三角法 THIRD ANGLE PROJECTION		名称 TITLE PTU-8764(A) 電源基板 POWER SUPPLY		
検図 CHECKED		尺度 SCALE				
製図 DRAWN	DEC. 27 '90 N. SAITO	重量 WEIGHT	kg	図番 DWG. NO. C3351-K03-C		

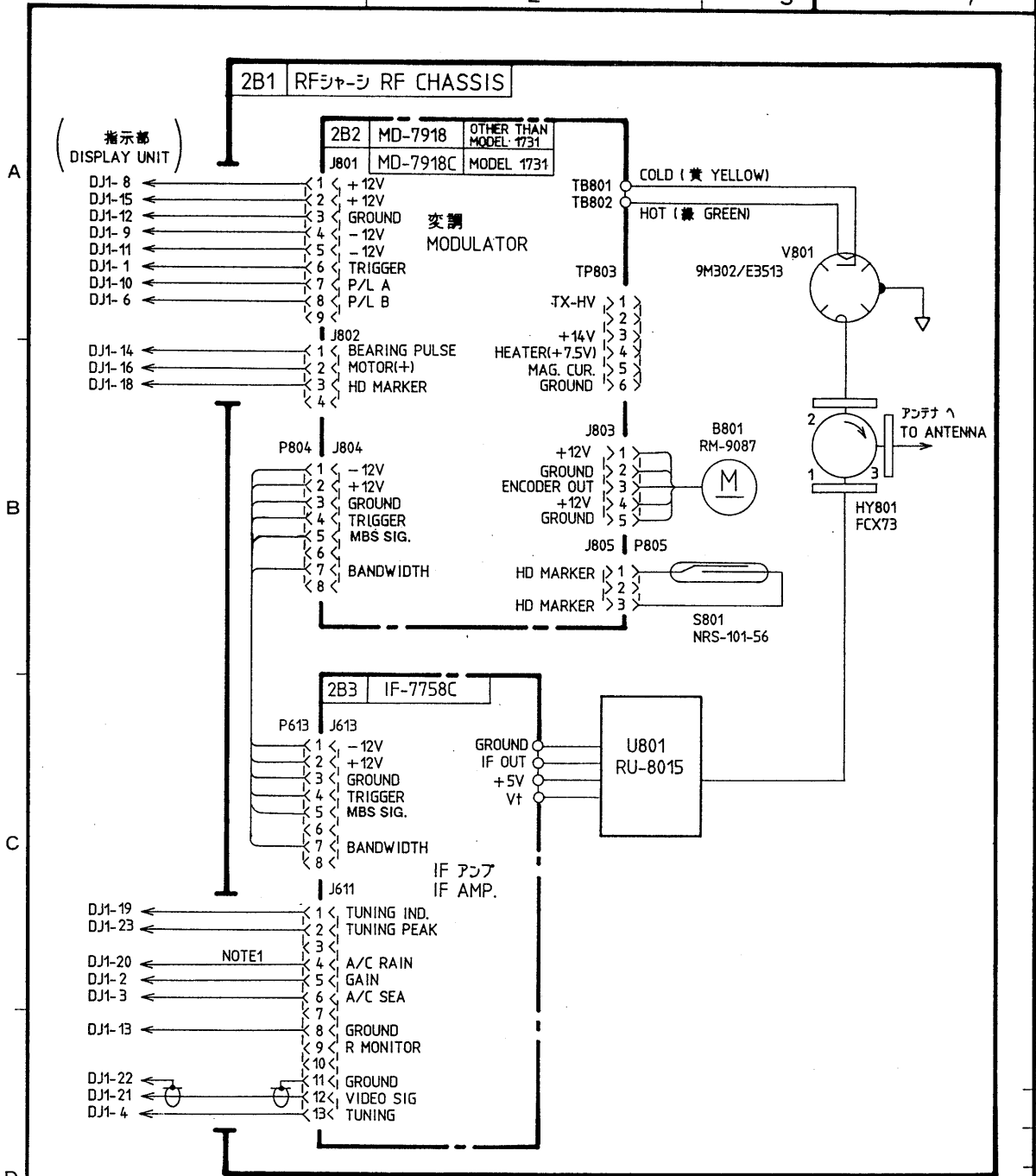

NOTE1. FR-7010D, FCR-1010, MODEL 1731の場合のみ. MODEL 1830/1730時は空き.  
 ONLY FOR FR-7010D, FCR-1010 AND MODEL 1731, WHILE NO CONNECTION FOR MODEL 1830/1730.

FCR-1010  
 MODEL 1730/1731  
 FR-7010D  
 MODEL 1830

承認 APPROVED	品番 ITEM	品名 NAME	材質 MATERIAL	数量 Q'TY	図番 DWG. NO.	摘要 REMARKS
LEB. 28. '89 T. L. AND		三角法 THIRD ANGLE PROJECTION				
検図 CHECKED	Feb. 28. '89 N. SAITO	尺度 SCALE				名称 TITLE 空中線部 SCANNER UNIT
製図 DRAWN	27th. Feb. '89 HATAI	重量 WEIGHT	kg		図番 DWG. NO. C3319-K05-H	

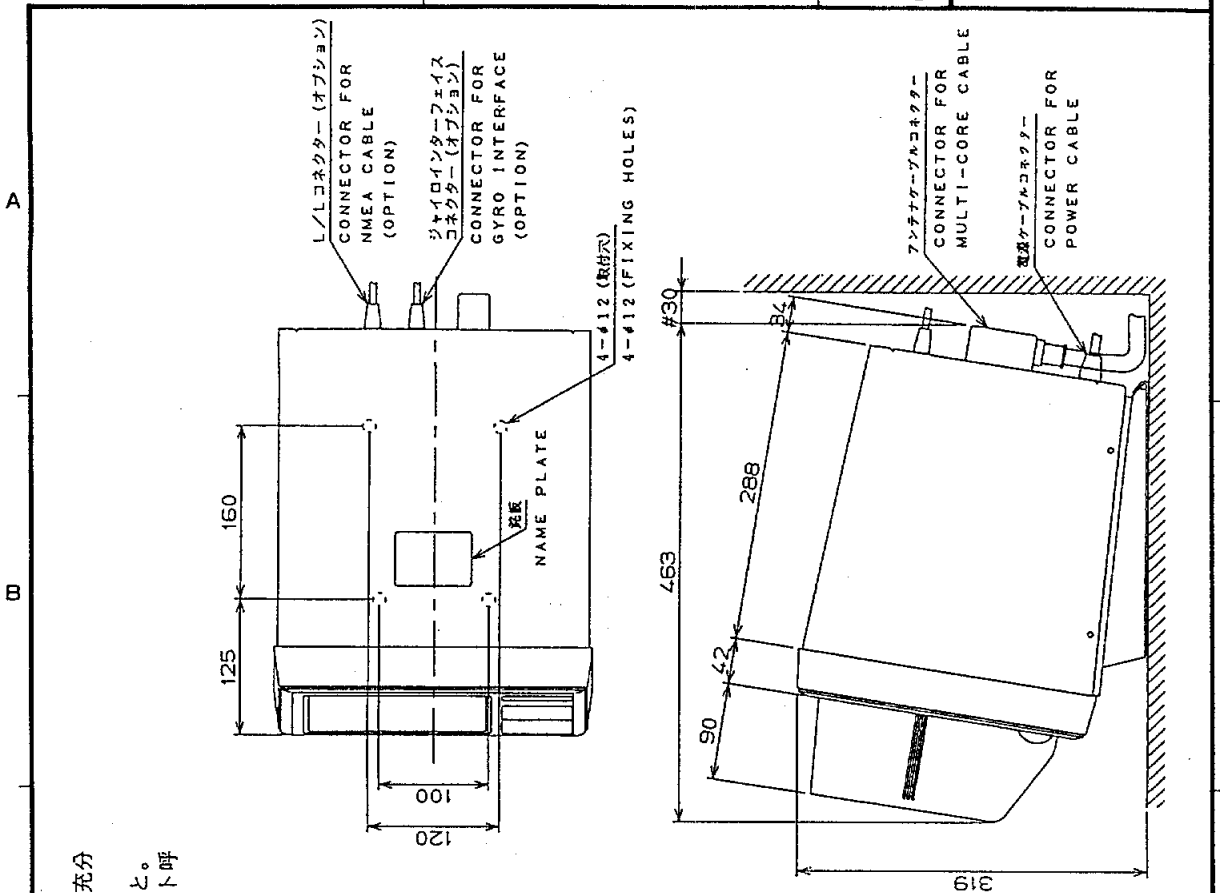

- 注記
- 1) 各接続ケーブルはサービstime時、指示部を前方に充分引き出せるよう余裕を持たせること。
  - 2) 各接続ケーブルの端末処理は装備要領参照のこと。
  - 3) 各取り付け用ネジはM10 ボルトまたはコーチボルト呼び径9を使用すること。
  - 4) #印寸法は最小サービstime空間とする。

- NOTE
- 1) LEAVE SUFFICIENT SLACK IN CABLES SO THAT THE UNIT CAN BE DRAWN OUT WITH THE CABLES CONNECTED FOR MAINTENANCE.
  - 2) REFER TO INSTALLATION INSTRUCTION TO FABRICATE THE CABLES.
  - 3) USE M10 BOLTS OR #9 COACH SCREWS FOR FIXING THE UNIT.
  - 4) #: RECOMMENDED SERVICING CLEARANCE.

コンパス安全距離  
 COMPASS SAFE DISTANCE

スタンダード STANDARD	0. 87 m
ステアリング STEERING	0. 65 m

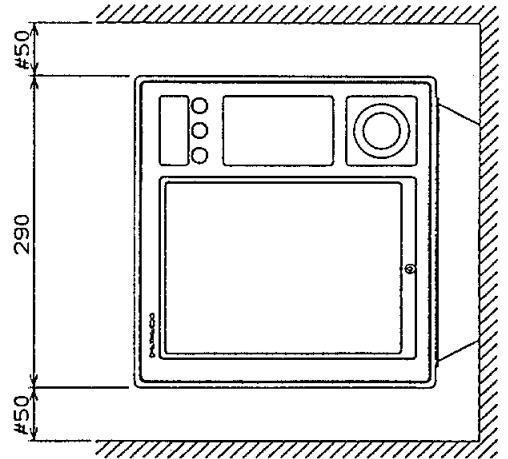

FCR-1010/1030/1040/1100		品番 ITEM	品名 NAME	材質 MATERIAL	数量 Q'TY	図番 DWG.NO.	摘要 REMARKS
承認 APPROVED	Nov. 27. '90 TAKAKAWA	三角法 THIRD ANGLE PROJECTION		名称 TITLE			
検図 CHECKED	Nov. 27. '90 N. SAITO	尺度 SCALE	1/6	レーダー指示部外寸図 RADAR DISPLAY UNIT			
製図 DRAWN	Nov. 27. '90 HATAI	重量 WEIGHT	10 kg	図番 DWG.NO. C3351-G01-A			

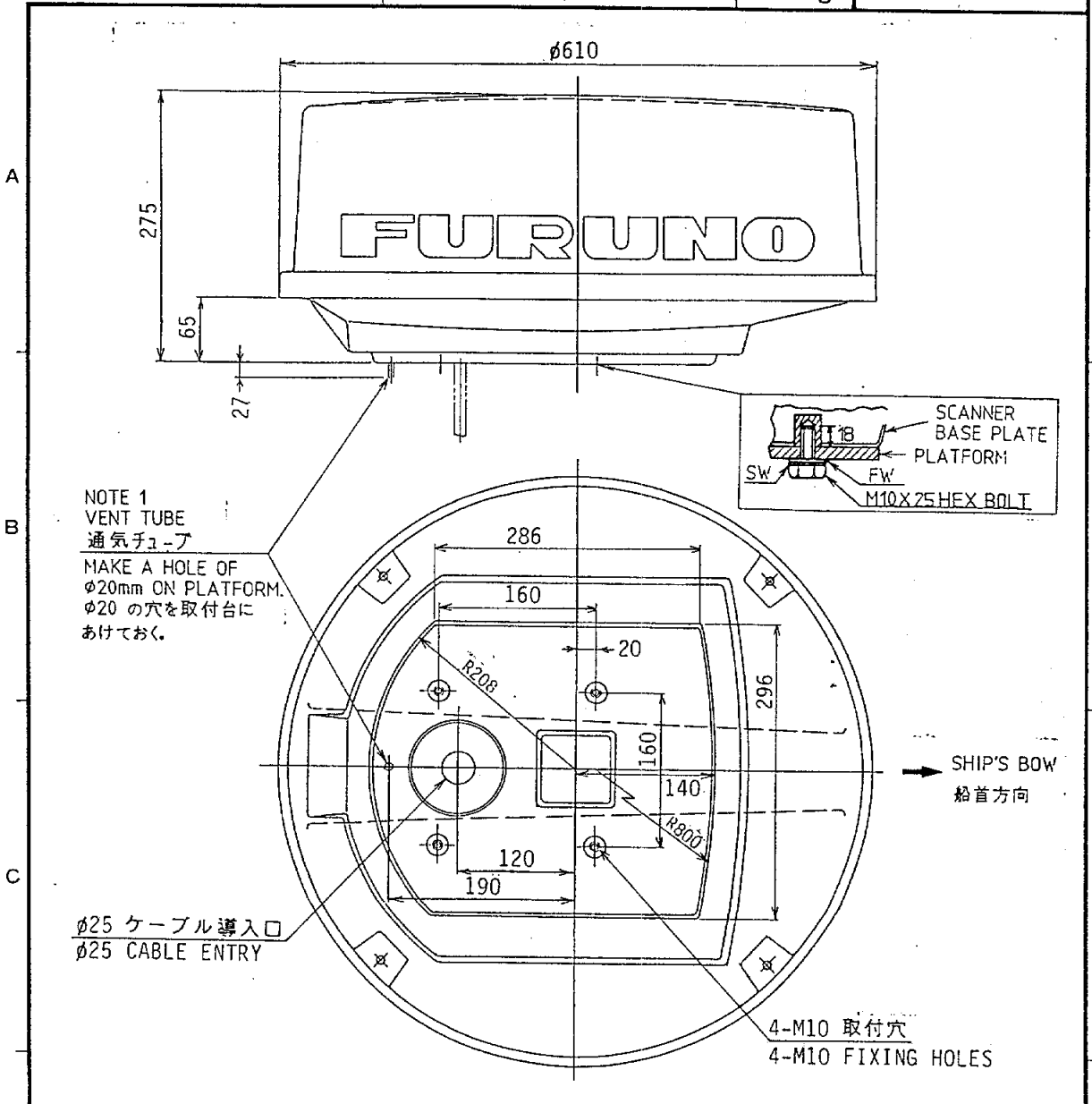

NOTE 1  
VENT TUBE  
通気チューブ  
MAKE A HOLE OF  
φ20mm ON PLATFORM.  
φ20 の穴を取付台に  
あけておく。

φ25 ケーブル導入口  
φ25 CABLE ENTRY

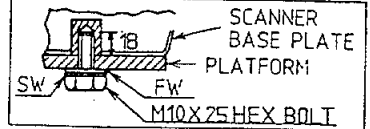

4-M10 取付穴  
4-M10 FIXING HOLES

NOTE 1: VENT TUBE IS FITTED AT FACTORY.

通気チューブは出荷時に取付済。

NOTE 2: COMPASS SAFE DISTANCE.

コンパス安全距離。

FCR-1010

FR-70100

MODEL 1730/1731/1830/1831

MODEL 1730/1731/1830/1831 MARK-2

MODEL 841

STANDARD スタンダード	3.1 m
STEERING ステアリング	1.75 m

品番 ITEM	品名 NAME	材質 MATERIAL	数量 Q'TY	図番 DWG.NO.	摘要 REMARKS
承認 APPROVED	JAN. 11. '89 T. NAKANO	三角法 THIRD ANGLE PROJECTION			
検図 CHECKED	11. JAN. '89 N. SHIRO	尺度 SCALE	1/6		レーダー空中線部外寸図 RADAR SCANNER UNIT
製図 DRAWN	11. JAN. '89 Y. HATAI	重量 WEIGHT	8 kg	図番 DWG.NO.	C 3319-006-J

## Free Manuals Download Website

<http://myh66.com>

<http://usermanuals.us>

<http://www.somanuals.com>

<http://www.4manuals.cc>

<http://www.manual-lib.com>

<http://www.404manual.com>

<http://www.luxmanual.com>

<http://aubethermostatmanual.com>

Golf course search by state

<http://golfingnear.com>

Email search by domain

<http://emailbydomain.com>

Auto manuals search

<http://auto.somanuals.com>

TV manuals search

<http://tv.somanuals.com>