

FURUNO

OPERATOR'S MANUAL

COLOR LCD SOUNDER

MODEL FCV-1100L



FURUNO ELECTRIC CO., LTD.
NISHINOMIYA, JAPAN

PRINTED IN JAPAN

© **FURUNO ELECTRIC CO., LTD.**

9-52, Ashihara-cho,
Nishinomiya, Japan

Telephone: 0798-65-2111
Telefax: 0798-65-4200

•Your Local Agent/Dealer

All rights reserved.

Printed in Japan

FIRST EDITION : AUG. 2001
C : NOV. 20, 2001

(DAMI)

PUB. No. OME-23670
FCV-1100L



* 00080921800 *



* OME23670C00 *



SAFETY INSTRUCTIONS



WARNING



ELECTRICAL SHOCK HAZARD
Do not open the equipment.

Only qualified personnel should work inside the equipment.

Immediately turn off the power at the switchboard if water leaks into the equipment or something is dropped in the equipment.

Continued use of the equipment can cause fire or electrical shock. Contact a FURUNO agent for service.

Do not disassemble or modify the equipment.

Fire, electrical shock or serious injury can result.

Immediately turn off the power at the switchboard if the equipment is emitting smoke or fire.

Continued use of the equipment can cause fire or electrical shock. Contact a FURUNO agent for service.

Make sure no rain or water splash leaks into the equipment.

Fire or electrical shock can result if water leaks in the equipment.



WARNING

Keep heater away from equipment.

A heater can melt the equipment's power cord, which can cause fire or electrical shock.

Use the proper fuse.

Fuse rating is shown on the equipment. Use of a wrong fuse can result in damage to the equipment.



CAUTION

A warning label is attached to the equipment. Do not remove the label. If the label is missing or illegible, contact a FURUNO agent or dealer.



WARNING



To avoid electrical shock, do not remove cover. No user-serviceable parts inside.

Name: Warning Label (2)
Type: 03-129-1001-0
Code No.: 100-236-740

About the TFT LCD

The TFT LCD is constructed using the latest LCD techniques, and displays 99.99% of its pixels. The remaining 0.01% of the pixels may drop out or blink, however this is not an indication of malfunction.

TABLE OF CONTENTS

FOREWORD	iv
SYSTEM CONFIGURATION	v
1. OPERATIONAL OVERVIEW	1-1
1.1 Controls.....	1-1
1.2 Indications	1-2
1.3 Turning the Power On/Off	1-2
1.4 Adjusting LCD Brilliance	1-3
1.5 Display Mode	1-4
1.6 Choosing Basic Range	1-11
1.7 Shifting the Basic Range.....	1-12
1.8 Adjusting Gain.....	1-13
1.9 Measuring Depth.....	1-13
1.10 Marker Line	1-14
1.11 Suppressing Clutter	1-15
1.12 Adjusting TVG.....	1-16
1.13 Eliminating Weak Echoes	1-17
1.14 Picture Advance Speed.....	1-18
1.15 A-Scope Display	1-20
1.16 Suppressing Interference.....	1-21
1.17 SHIFT/PROG Key.....	1-22
2. MENU OPERATION	2-1
2.1 Basic Menu Operation	2-1
2.2 DISP Menu	2-3
2.3 ALM Menu.....	2-6
2.4 TX/RX Menu.....	2-8
2.5 E/S Menu	2-10
2.6 USER Menu	2-12
3. SYSTEM MENU	3-1
3.1 SYSTEM Menu Operation	3-1
3.2 SYSTEM SETTING Menu	3-2
3.3 DRAFT SETTING Menu	3-4
3.4 RANGE SETTING Menu.....	3-5
3.5 TEMP SETTING Menu	3-7
3.6 NAV DATA SETTING Menu	3-8
3.7 TARGET ECHO Menu	3-10
4. INTERPRETING THE DISPLAY	4-1
4.1 Color Bar	4-1
4.2 Zero Line	4-2
4.3 Bottom Echoes.....	4-2
4.4 Fish School Echoes	4-3
4.5 Other Echoes	4-4

5. MAINTENANCE, TROUBLESHOOTING	5-1
5.1 Maintenance.....	5-1
5.2 Fuse Replacement.....	5-2
5.3 Troubleshooting	5-2
5.4 Diagnostic Test.....	5-3
5.5 Test Pattern	5-5
5.6 Restoring Default Settings	5-6
APPENDIX	A-1
Menu Tree	A-1
Screen Division	A-6
Display Division.....	A-9
SPECIFICATIONS	SP-1
INDEX	

FOREWORD

A Word to FCV-1100L Owners

Congratulations on your choice of the FURUNO FCV-1100L COLOR LCD SOUNDER. We are confident you will see why the FURUNO name has become synonymous with quality and reliability.

For over 50 years FURUNO Electric Company has enjoyed an enviable reputation for innovative and dependable marine electronics equipment. This dedication to excellence is furthered by our extensive global network of agents and dealers.

This equipment is designed and constructed to meet the rigorous demands of the marine environment. However, no machine can perform its intended function unless installed, operated and maintained properly. Please carefully read and follow the recommended procedures for operation and maintenance.

We would appreciate hearing from you, the end-user, about whether we are achieving our purposes.

Thank you for considering and purchasing FURUNO equipment.

Features

- 16-color (including background) presentation provides detailed information on fish density and bottom composition, on a 10.4-inch color LCD. 8-color presentation also available.
- FURUNO Free Synthesizer (FFS) transceiver design allows use of user-selectable operating frequencies.
- Automatic bottom tracking feature permits unattended operation.
- Frequency mixing picture helps discriminate fish species.
- Alarms: Fish, Bottom, Fish-Bottom, Water Temperature (temperature data required).
- A-scope presentation displays echoes at each transmission with amplitudes and colors according to intensities.
- Unique split range control allows independent range settings in dual-frequency mode.

SYSTEM CONFIGURATION

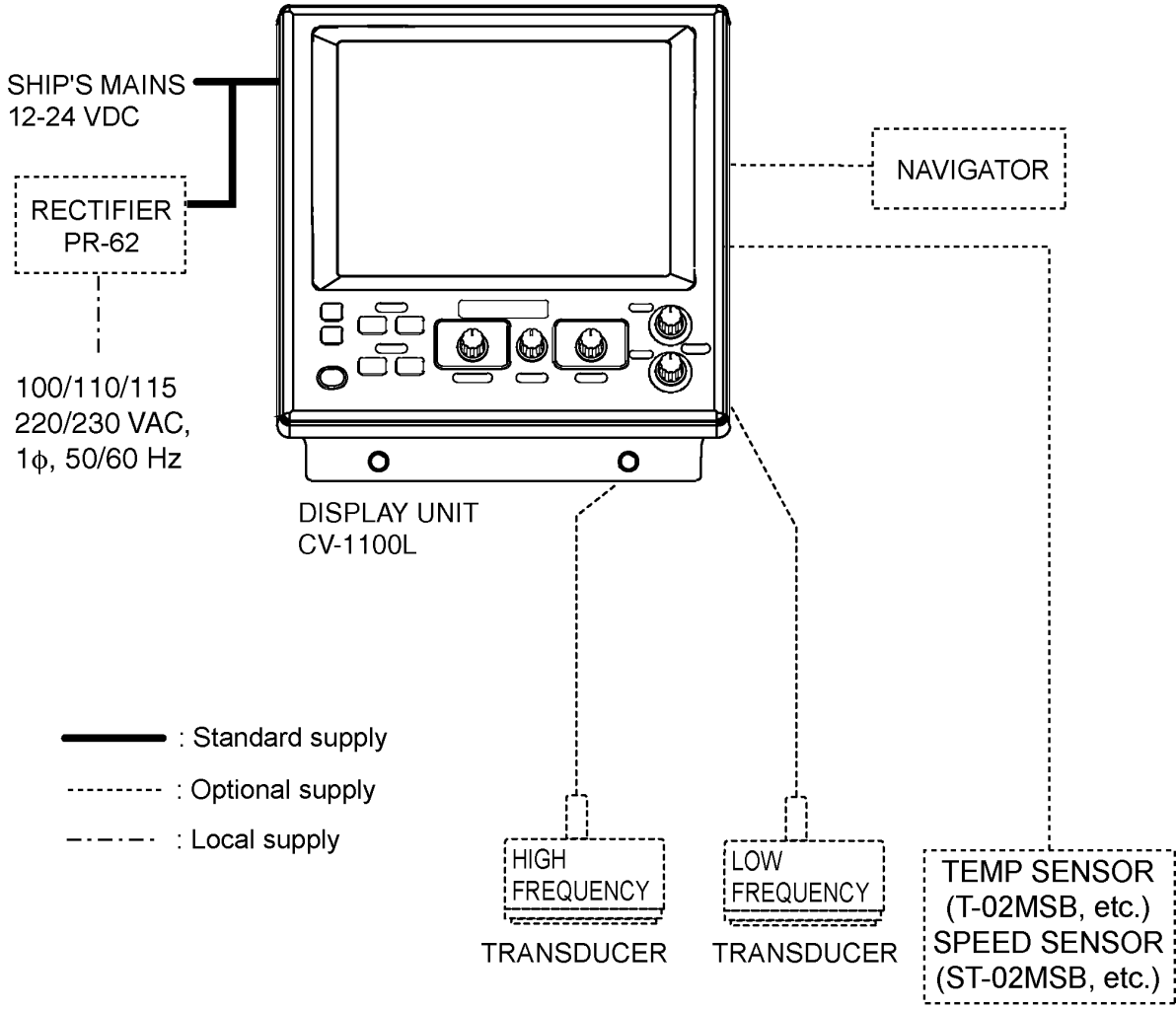

System configuration

This page is intentionally left blank.

1. OPERATIONAL OVERVIEW

1.1 Controls

Correct key operation: One beep
 Invalid key operation: Two beeps

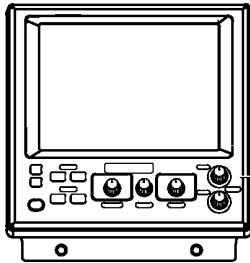

Control Panel

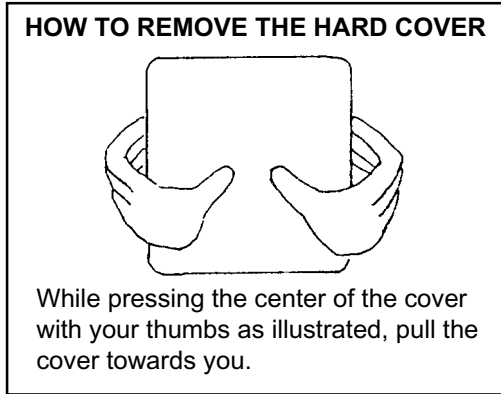

Adjusts display brilliance.
 (P. 1-3)

Inscribes vertical line on the display.
 Current position is output to navigation plotter with connection of navigator.
 (P. 1-14)

- Shifts the display area. (P. 1-12)
- Changes menu setting. (P. 2-1)
- Executes programmed function. (P. 1-22)

Selects a display.
 (P. 1-4)

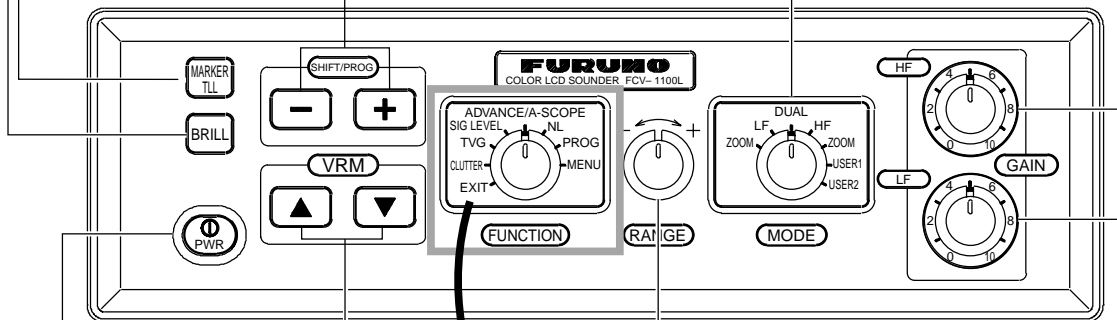

Turns power on/off. (P. 1-2)

Selects a display range. (P. 1-11)

Adjusts gain of high and low frequencies individually.
 (P. 1-13)

- Shifts VRM/White Marker. (P. 1-13, P. 2-4)
- Selects menu item. (P. 2-1)

Opens the SIGNAL LEVEL menu. (P. 1-17)

Opens the PIC ADVANCE/A-SCOPE menu. (P. 1-18, P. 1-20)

Opens the TVG menu. (P. 1-16)

Opens the NOISE LIMITER menu. (P. 1-21)

Opens the CLUTTER menu. (P. 1-15)

Opens the USER menu. (P. 2-12)

Closes menu.

Opens the main menu. (P. 2-1)

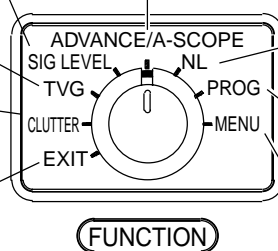

Controls

1. OPERATIONAL OVERVIEW

1.2 Indications

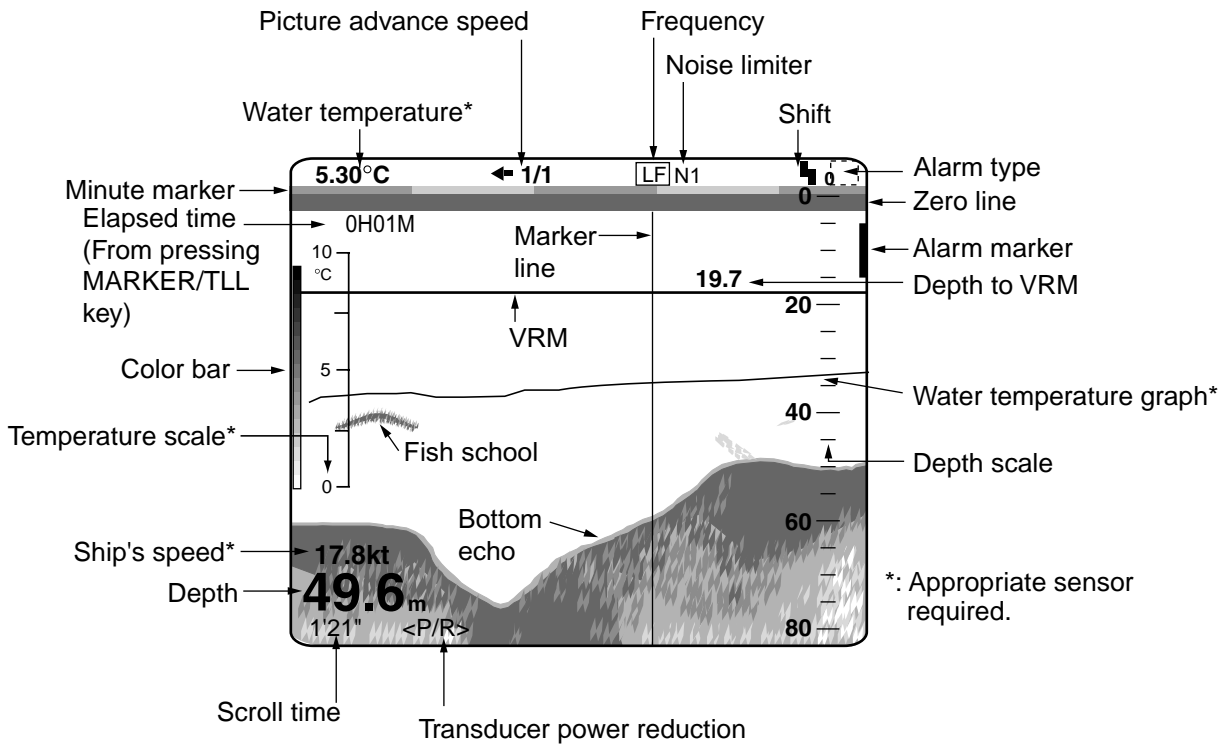

Indications

1.3 Turning the Power On/Off

1. Press the [PWR] key. A beep sounds, and then the power turns on.
2. Press the [PWR] key again to turn the power off.

Note 1: Wait five seconds before turning on the power again.

Note 2: The example screens shown in this manual may not match the screens you see on your display. The screen you see depends on your system configuration and equipment settings.

1.4 Adjusting LCD Brilliance

The brilliance of the LCD may be adjusted as below. Ten levels are available.

1. Press the [BRILL] key.

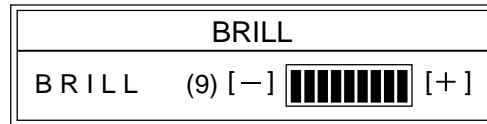

Brill window

2. Press the [+] or [-] key to adjust the LCD brilliance; [+] key to raise the brilliance, [-] key to lower it.

Note 1: Brilliance is automatically set to maximum at the next power on, when the unit is turned off with the brilliance setting of 4 or lower.

Note 2: Brilliance must be adjusted within five seconds after pressing the [BRILL] key or the brill window will be erased.

1.5 Display Mode

Seven display modes are available with the [MODE] switch.

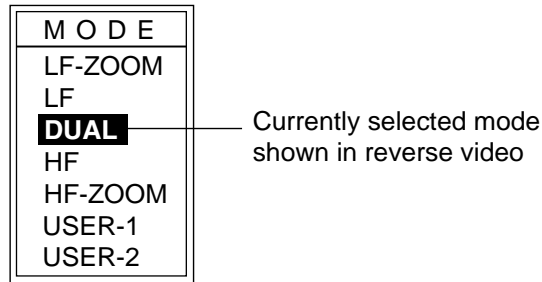

Display mode window

1.5.1 Single-picture (low frequency or high frequency) display

Low frequency (LF)

The lower the frequency of the ultrasonic pulse the wider the detection area. Thus, the low frequency is suitable for general search and judging bottom condition.

High frequency (HF)

The higher the frequency of the ultrasonic pulse the better the resolution. Therefore, the high frequency pulse is useful for detailed observation of fish echoes.

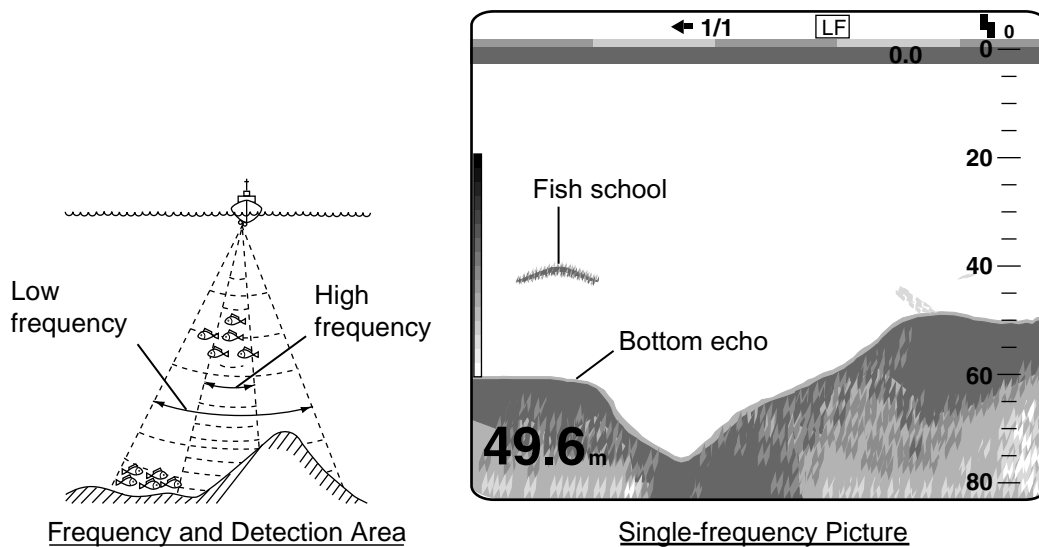

Frequency and detection area, sample single picture (low frequency)

1.5.2 Dual frequency display

The dual frequency display provides the low frequency picture on the left half of the screen; the high frequency picture on the right half.

Frequency	Beamwidth	Echo Trail
Low	Wide	Long
High	Narrow	Short

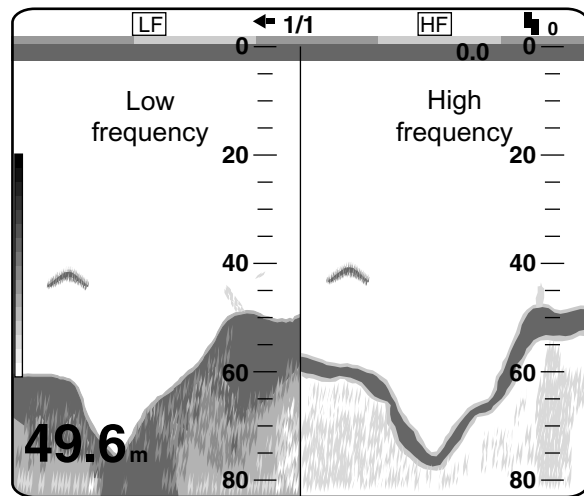

Dual frequency display

1.5.3 Zoom displays

The “single-frequency picture” (high or low frequency) appears on the right half of the screen and the zoom picture on the left half. The zoom picture may be pre-chosen among bottom lock, bottom zoom, marker zoom and discrimination, from the SYSTEM SETTING menu. For further details, see ZOOM MODE on page 3-3.

Bottom-lock display

The bottom-lock display shows the area between the zoom marker and the bottom as a straight line to distinguish it from fish near the bottom, and thus it is useful for discriminating fish near the bottom.

The bottom-lock zoom range may be chosen on the RANGE SETTING menu. For further details see B/L RANGE on page 3-5.

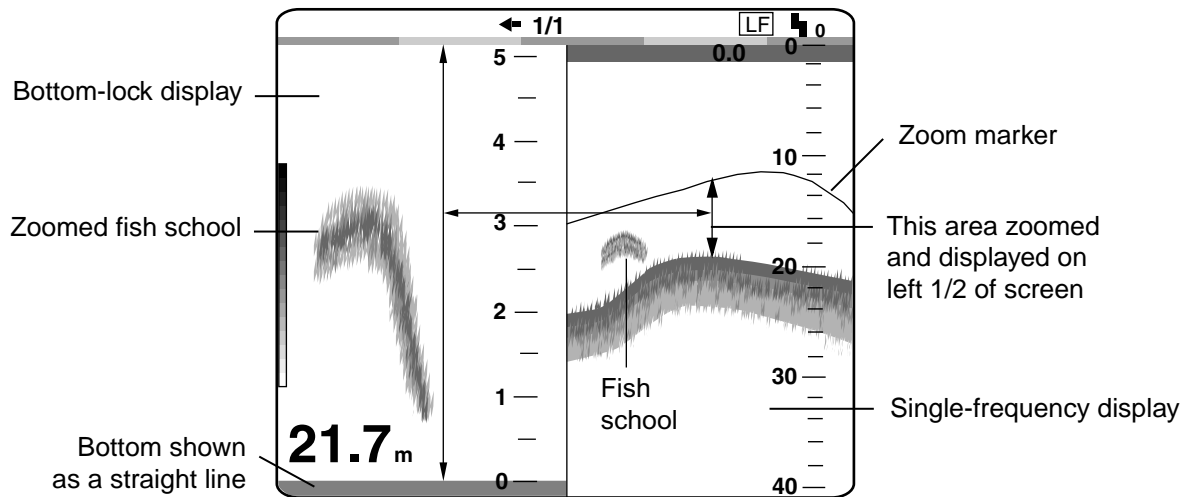

Bottom-lock display

Bottom-zoom display

The bottom-zoom display shows the zoomed bottom (automatically tracked) on the left half of the screen. When the bottom depth increases, the display shifts to keep the bottom echo at the lower part of the screen.

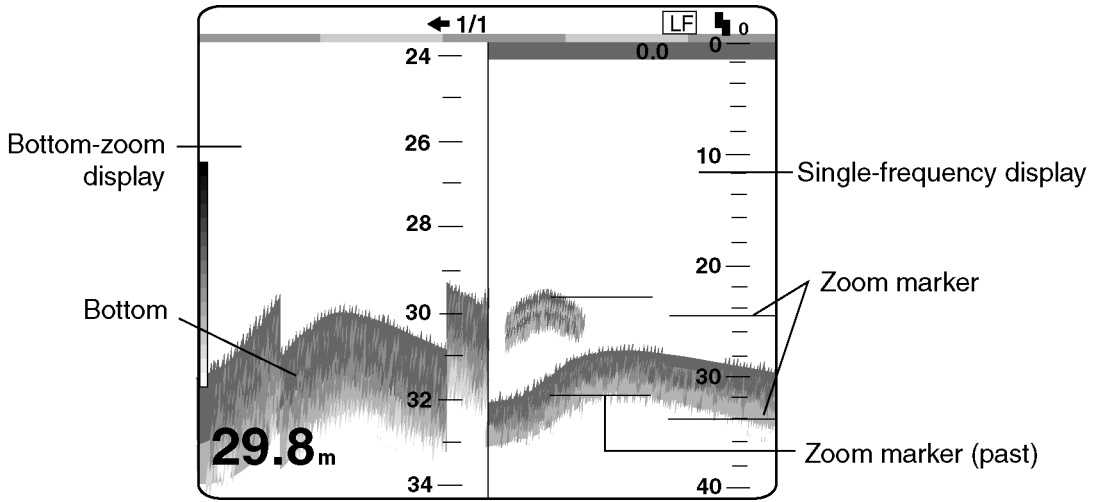

Bottom-zoom display

Marker-zoom display

The marker-zoom display expands the area chosen with the VRM on the normal picture to full vertical size of the screen on the left half of the screen. This mode is useful for observing a specific fish school.

The marker-zoom range may be chosen on the RANGE SETTING menu. For further details see M/Z RANGE on page 3-5.

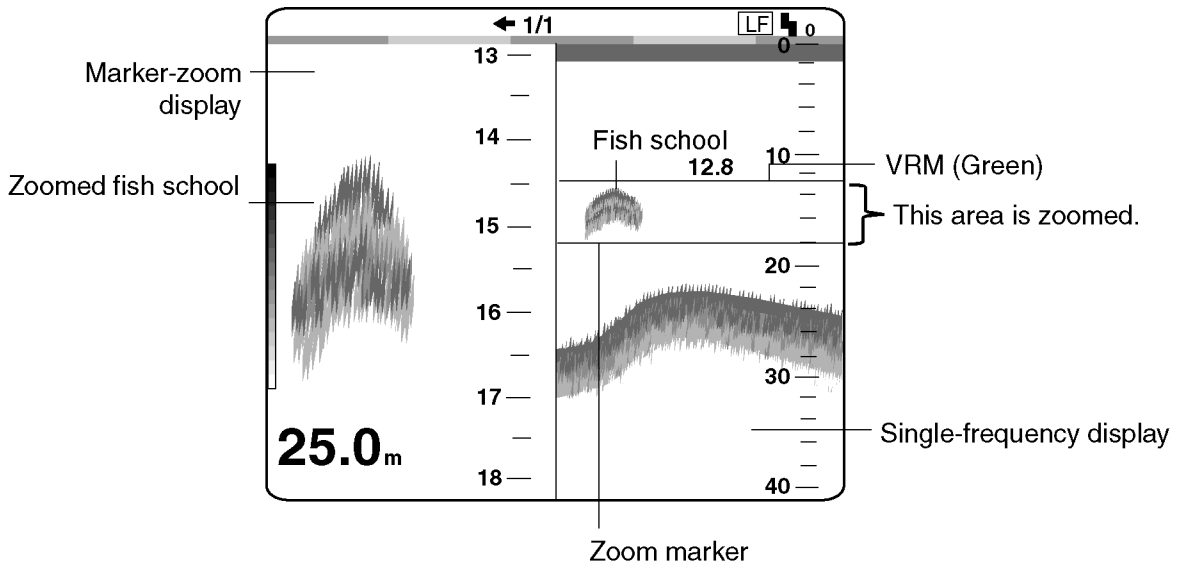

Marker-zoom display

1. OPERATIONAL OVERVIEW

DISCRIM 1/2 display

The discrim(ination) 1/2 screen shows the single picture on the right half of the screen and the bottom-lock display and discriminator display occupy the left half of the screen. The discriminator display shows the bottom as a straight line, which is useful for determining bottom hardness.

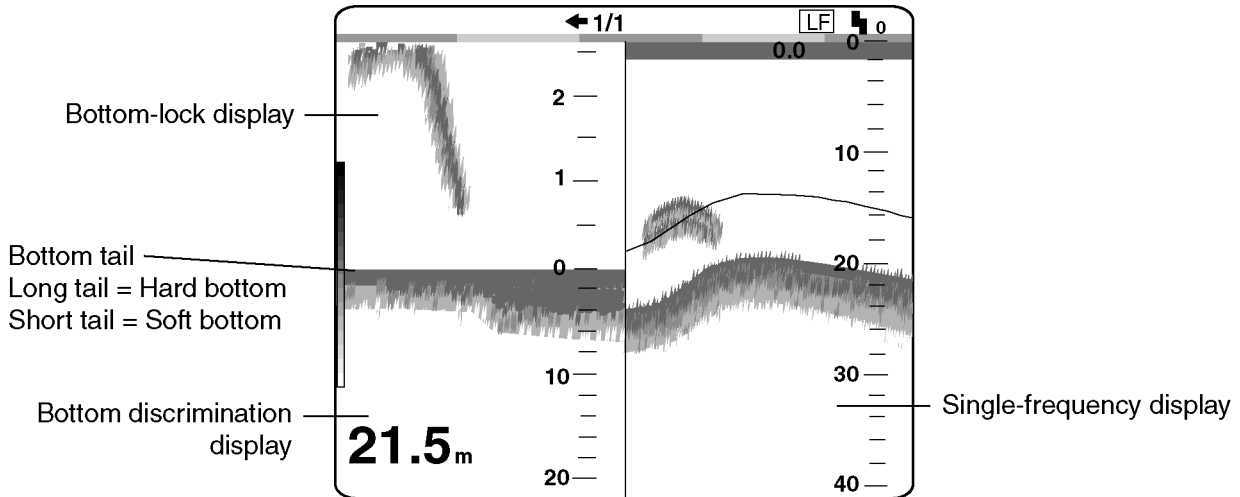

Discrimination 1/2 display

DISCRIM 1/3 display

This display is similar to the DISCRIM 1/2 display except the bottom discriminator display occupies the bottom one-third of the left half of the screen as below.

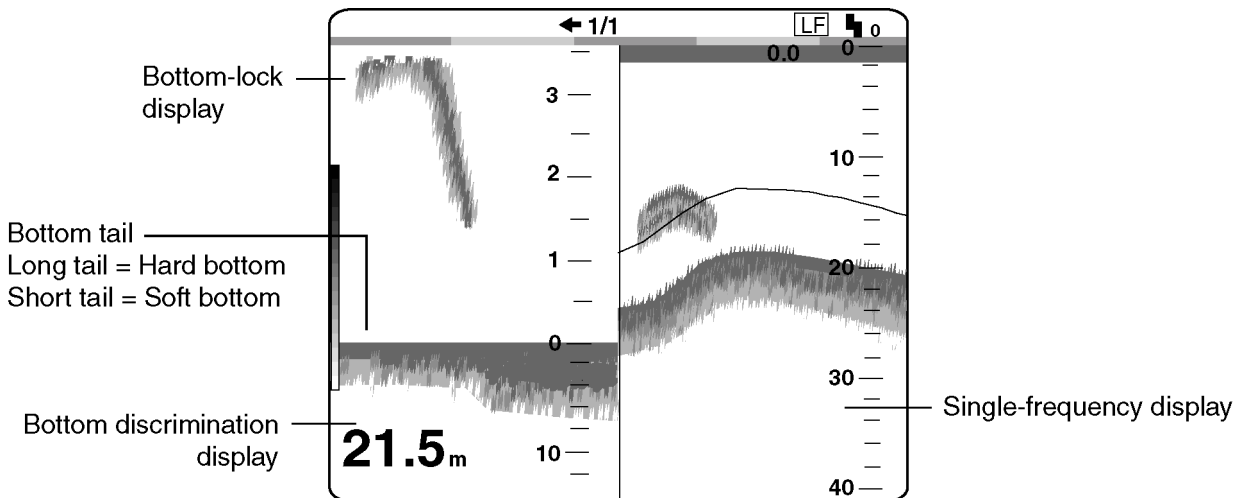

Discrimination 1/3 display

1.5.4 USER-1, -2 displays

The display programmed at USER-1/2 on the USER menu appears. The default settings are as follows:

USER 1: Screen is split vertically in thirds (LF + HF + MIX)

USER 2: Screen is split vertically in fourths (LF + HF + LF bottom zoom +HF bottom zoom)

This setting may be changed through the USER menu. For further details, see "USER-1/2" on page 2-12.

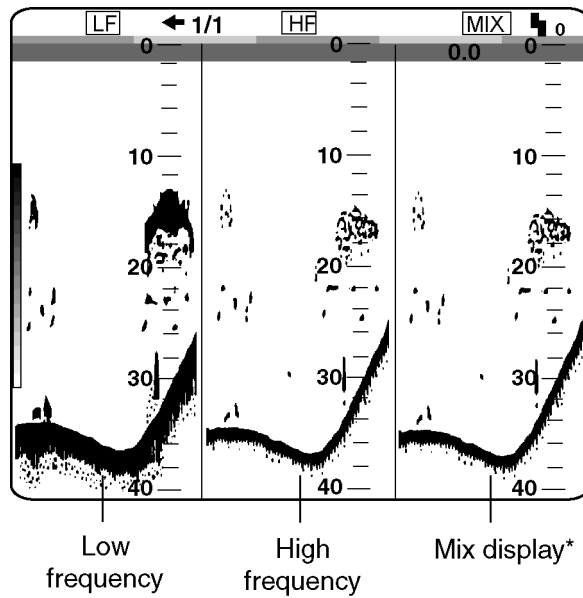

User 1 display (default display)

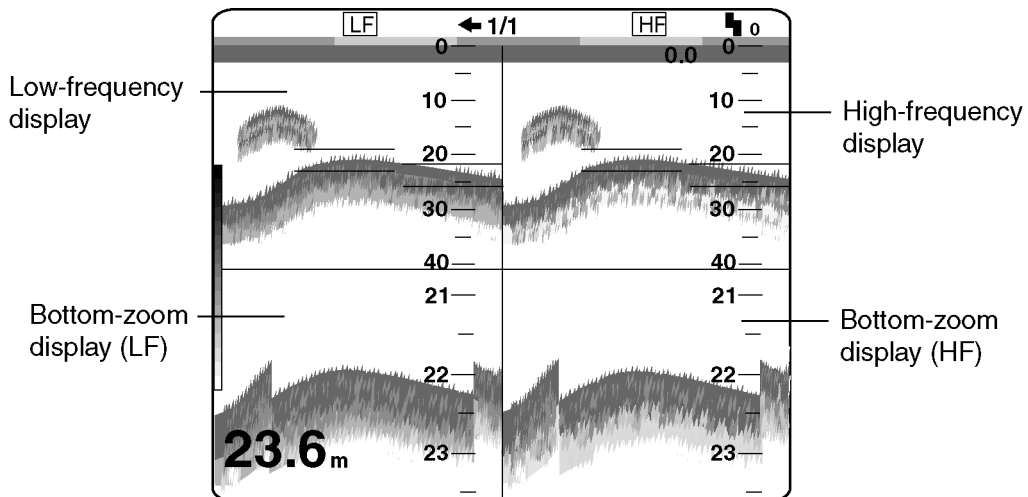

User 2 display (default display)

1. OPERATIONAL OVERVIEW

Mix display

The mix display compares echo intensity between low and high frequencies, and displays echoes from tiny fish in discriminative colors. This is done by utilizing the fact that tiny fish return a stronger echo against a high frequency rather than a low frequency. This is done as below.

1. If a high frequency echo is stronger than the corresponding echo on the low frequency, the high frequency echo is displayed.
2. If the low frequency echo is stronger than or equal to the high frequency echo, it is less likely to be a tiny fish and therefore is displayed in blue.
3. If the echoes on both frequencies have the intensity corresponding to reddish-brown or red, they are displayed in reddish-brown or red: this is necessary to display the zero line and bottom in reddish-brown or red.
4. In other words, the echoes displayed in orange thru light-blue may be considered to be tiny fish such as whitebait.

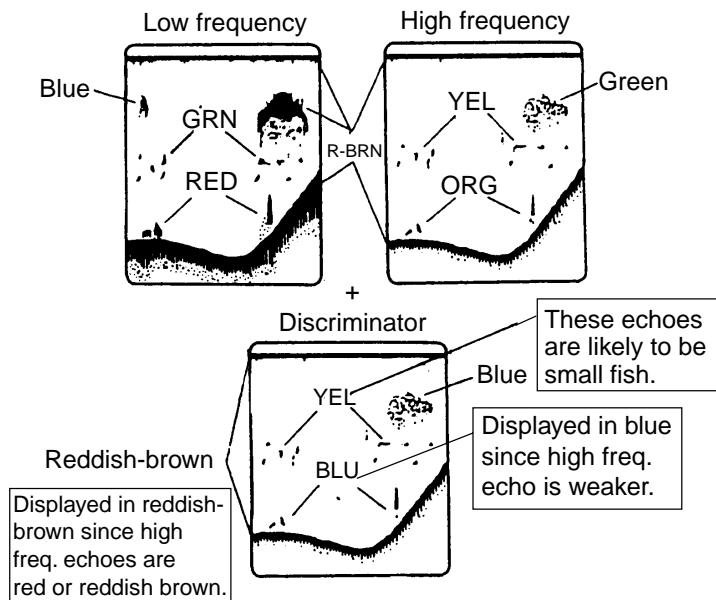

How the mix display works

1.6 Choosing Basic Range

The basic range may be chosen with the [RANGE] switch from the eight ranges listed below. These eight ranges may be programmed as desired on the RANGE SETTING menu. For details, see page 3-5.

R A N G E
3 0 f t
6 0 f t
1 2 0 f t
2 5 0 f t
5 0 0 f t
1 0 0 0 f t
1 6 0 0 f t
3 0 0 0 f t

Range setting window (example: feet)

Basic ranges (default settings)

Range Unit	Range Switch Position							
	1	2	3	4	5	6	7	8
Feet (default)	30	60	120	250	500	1000	1600	3000
Meter	10	20	40	80	150	300	500	1000
Fathom	5	10	20	40	80	160	250	500
Hiro (Japanese)	6	12	25	50	100	200	300	600
Passi/Braza	6	12	25	50	100	200	300	600

Note 1: This setting must be done within five seconds after rotating the [RANGE] switch once, otherwise the range window will be erased.

Note 2: Range for high and low frequencies can be set separately.

Note 3: The unit of depth measurement may be chosen from the SYSTEM SETTING menu. For details, see DEPTH UNIT on page 3-2.

1.7 Shifting the Basic Range

The [-] and [+] keys determine the start depth (shown at the top of the screen) of the picture. In the default setting any shift is reflected on other ranges. This feature is not available when AUTO SHIFT is active.

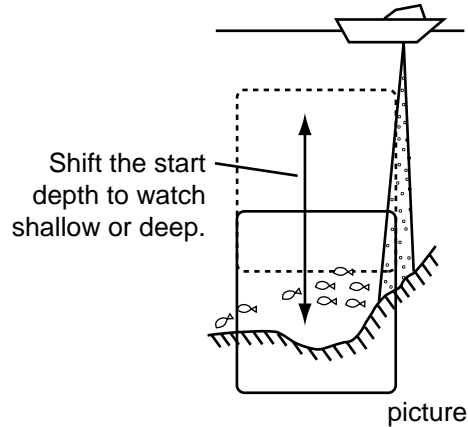

Principle of shift

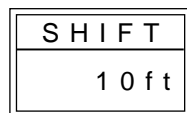

Shift window (screen center), shift indication (top right corner)

- Note 1:** This operation must be done within five seconds after pressing the [-] or [+] key, otherwise the shift window will be erased.
- Note 2:** Automatic shift, which provides virtually hands-free automatic operation, is also available. For further details, see AUTO SHIFT on page 3-3.
- Note 3:** You can shift the display independently for each range by turning on FREE SHIFT, on the SYSTEM SETTING menu. For details, see FREE SHIFT on page 3-2.

1.8 Adjusting Gain

The [GAIN] control adjusts the sensitivity of the receiver. Adjust it so excessive noise just disappears from the screen.

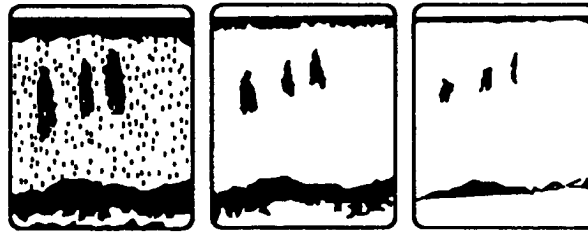

Gain too high

Gain proper

Gain too low

Examples of proper and improper gain levels

1.9 Measuring Depth

Use the [▲] or [▼] key to place the VRM on the object to measure depth. Depth is digitally displayed above the VRM.

Note: This operation is available by setting MARKER SELECT on the DISP menu to "VRM."

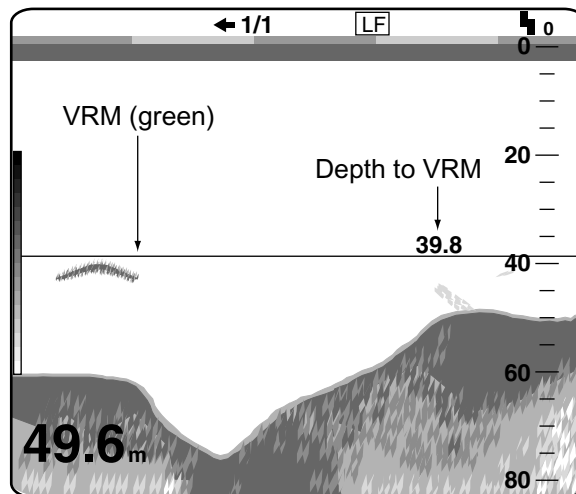

How to use the VRM

1.10 Marker Line

The [MARKER/TLL] key inscribes a vertical marker line on the screen when pressed. It may be used to denote a fish school or other important echo.

At the same moment the key is pressed, latitude and longitude position are output to a navigation plotter and marked on its screen if this unit is interfaced with position-fixing equipment.

Elapsed time from the moment the [MARKER/TLL] key is pressed may be displayed at the upper-left corner of the screen. For further details, see SCROLL TIME on page 2-3.

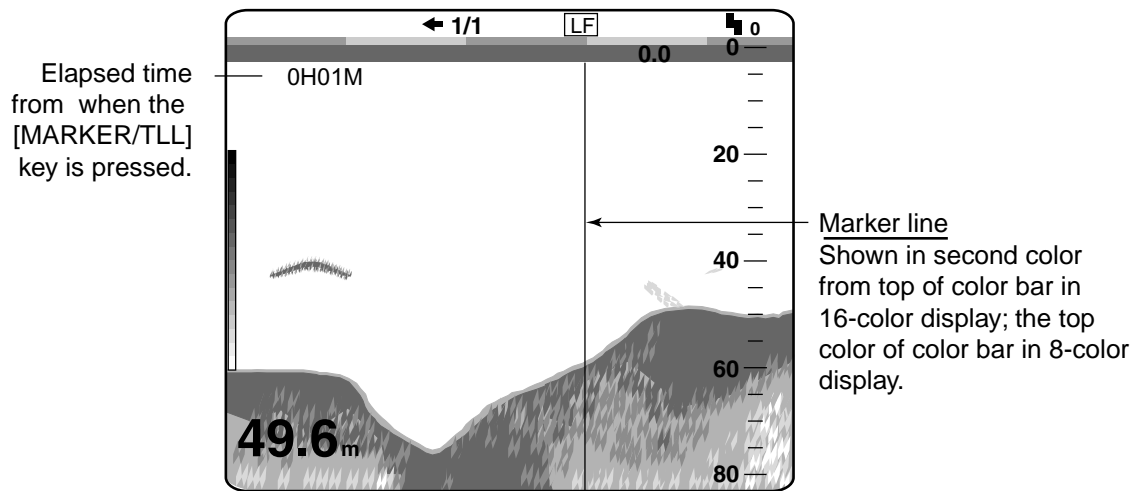

Marker line and elapsed time indication

1.11 Suppressing Clutter

When blue dots appear over the entire screen (mainly caused by sediments in the water), use the clutter function to suppress them.

1. Rotate the [FUNCTION] switch to choose CLUTTER.

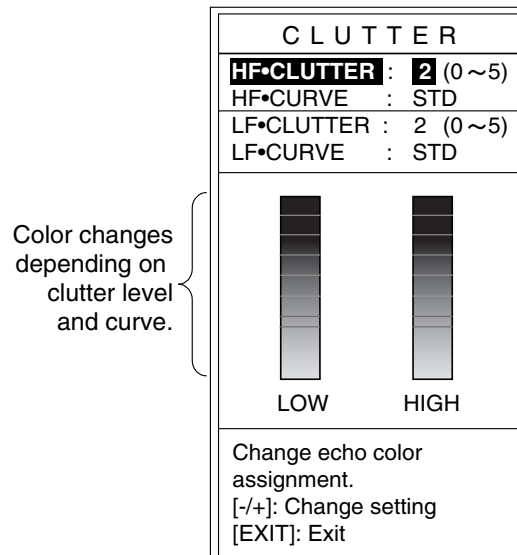

Clutter menu

- For dual frequency display: Go to step 2.
 - For other modes: Go to step 3 after pressing the [▼] key.
2. Press the [▲] or [▼] key to choose HF CURVE or LF CURVE as appropriate.
 3. Press the [-] or [+] key to open the clutter curve selection window (default: STD).



Clutter curve selection window

STD: The higher the clutter level the smaller weak echoes are displayed.
 LINEAR: The higher the clutter level the smaller all echoes are displayed.
 CUSTOM: Applies the user clutter settings from the user clutter menu. See page 2-17.

4. Press the [-] or [+] key to choose clutter curve desired.
5. Press the [▲] or [▼] key to close the window.
6. Press the [▲] key to choose HF CLUTTER or LF CLUTTER as appropriate.
7. Press the [-] or [+] key to set clutter rejection level: 0, OFF; 1, weakest, 5, strongest.
8. Rotate the [FUNCTION] switch fully counterclockwise to choose EXIT.

Note: Clutter cannot be adjusted manually when using the auto mode. Turn off the auto mode on the E/S menu to manually adjust clutter. For details see page 2-11.

1.12 Adjusting TVG

The TVG compensates for propagation loss of sound, so that the echoes from the same size fish schools are displayed in the same color. Avoid excessive TVG; weak echoes may not be displayed. The TVG is also useful for reducing surface noise.

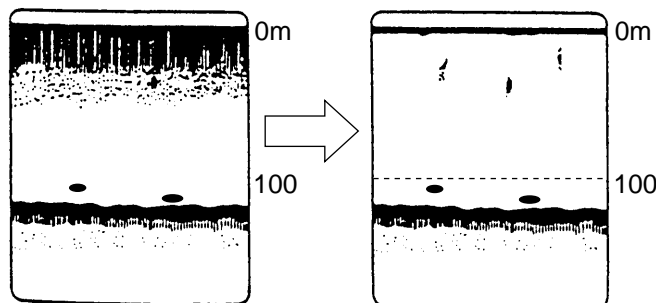

How TVG works

1. Rotate the [FUNCTION] switch to choose TVG.

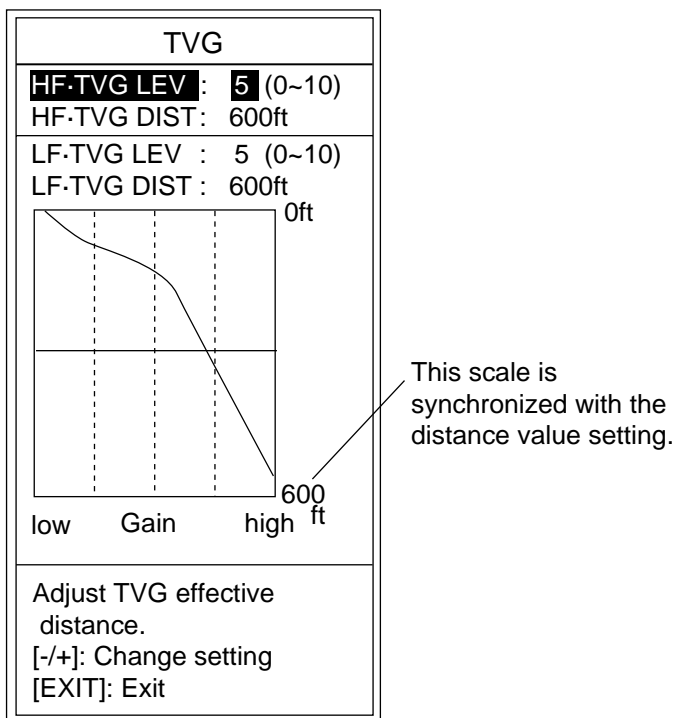

TVG menu

- For dual display: Go to step 2.
 - For other display modes: Go to step 3 after pressing the [▼] key.
2. Press the [▲] or [▼] key to choose HF TVG DIST or LF TVG DIST as appropriate.
 3. Press the [-] or [+] key to set the TVG distance. The larger the setting, the longer the range at which TVG works. The scale on the menu synchronizes with the rate setting.
 4. Press the [▲] or [▼] key to close the window.

5. When surface noise appears in the range shallower than the setting range, press the [▲] key to choose HF TVG LEVEL or LF TVG LEVEL as appropriate.
6. Press the [-] or [+] key to set the TVG level in the setting window. The higher the TVG level, the less the gain near distance.



TVG level setting window

7. Rotate the [FUNCTION] switch fully counterclockwise to choose EXIT.

1.13 Eliminating Weak Echoes

Sediments in the water or reflections from plankton may be painted on the display in green or light-blue. These weak echoes may be erased with the signal level function.

1. Rotate the [FUNCTION] switch to choose SIG LEVEL.

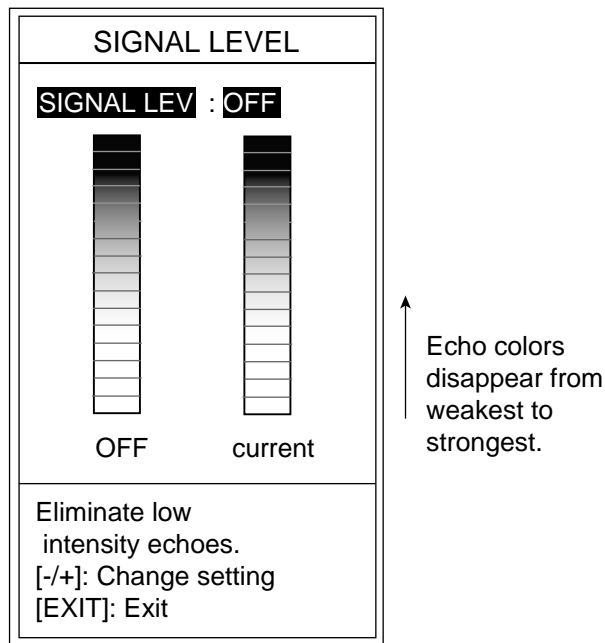

Signal level menu

2. Press the [-] or [+] key to choose the setting desired. Every pressing of the [+] key deletes echoes from weakest to strongest in ascending order. (For eight colors, the setting window shows OFF, 1 to 4.)

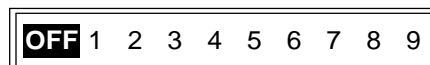

Signal level setting window (for 16 colors)

3. Rotate the [FUNCTION] switch fully counterclockwise to choose EXIT.

1.14 Picture Advance Speed

The picture advance speed determines how quickly the vertical scan lines run across the screen.

1. Rotate the [FUNCTION] switch to choose ADVANCE/A-SCOPE.

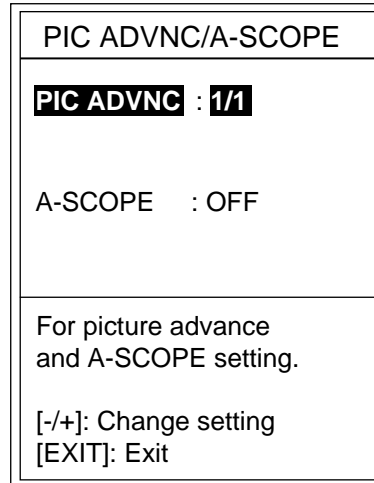

PIC ADVNC/A-SCOPE menu

2. Press the [-] or [+] key to choose the speed desired.

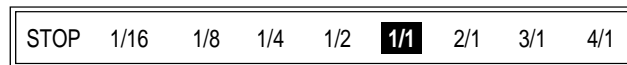

Picture advance speed setting window

The fractions in the window mean the number of vertical scan lines produced per transmission. For example, "1/2" means a vertical scan line is produced every two transmissions. These fractions also appear at the top of the screen for your reference.

When choosing an advance speed, keep in mind that a fast advance speed will expand the size of a fish school horizontally and a slow speed will contract it.

← 1/1 (S) ← "S" means picture advance speed is synchronized with ship's speed.

Speed indication

3. Rotate the [FUNCTION] switch fully counterclockwise to choose EXIT.

Ship's speed dependent mode

With speed data provided by a speed log, current indicator or navigation equipment, the display advance speed may be set according to ship's speed, the ship's speed dependent mode. As shown in the figure below the horizontal scale of the display is not influenced by the change of ship's speed, thus the speed-dependent picture advance permits judgment of fish school size and abundance at any speed. The picture advance speed indication is suffixed with an "S" when the ship's speed dependent mode is active. For example, "1/1S." This function is available with ship's speed of 2-20 kt. You can use the ship's speed dependent mode by setting PRR LEVEL to "S" on the TX/RX menu. For further details, see PRR LEVEL on page 2-8.

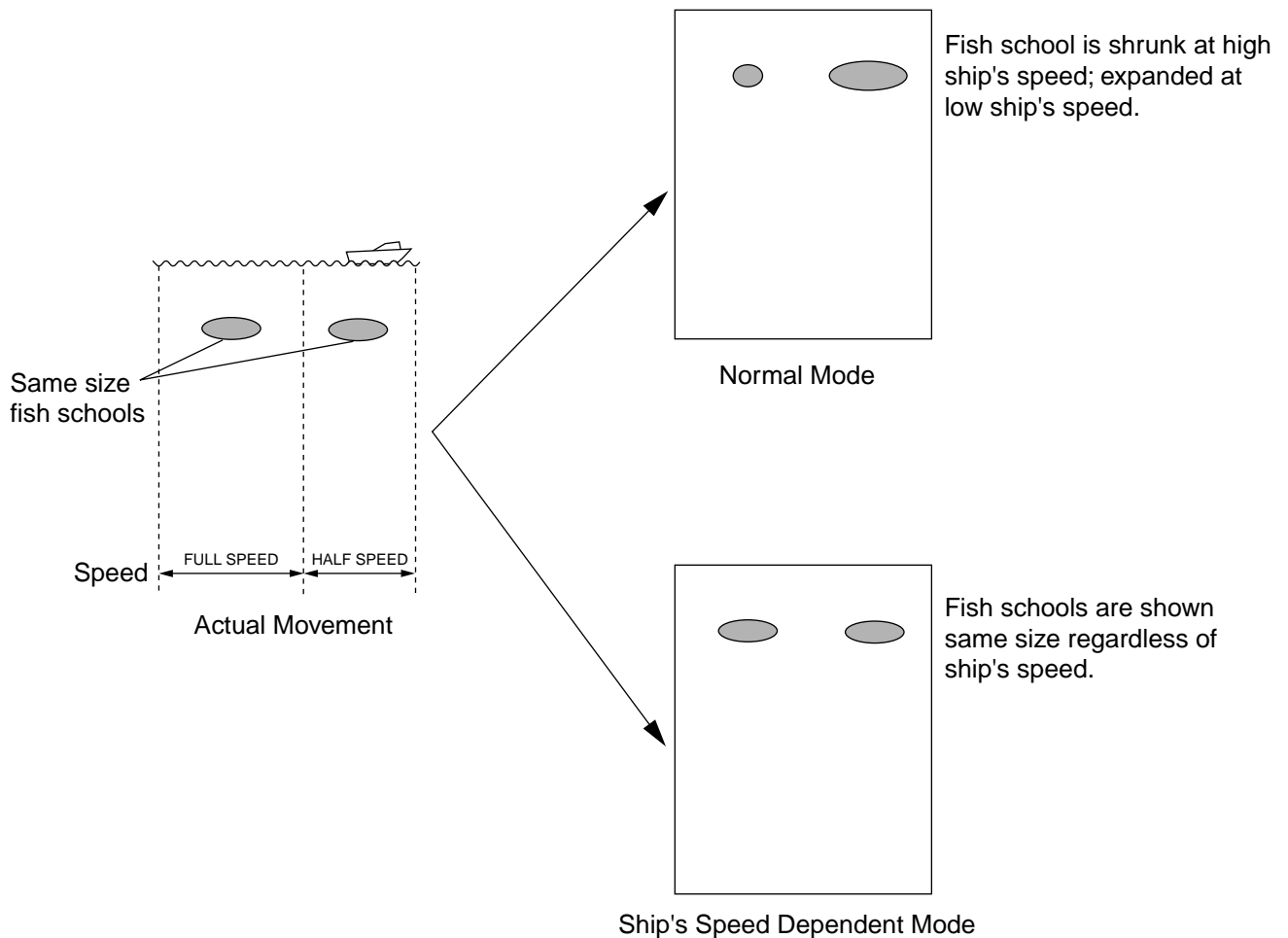

How the ship's speed dependent mode works

1.15 A-Scope Display

The A-scope picture displays echoes at each transmission with amplitudes and colors proportional to their intensities on the right one-fourth of the screen. This feature is useful for close observation of small fish and fish near the bottom.

Note: For the dual-frequency display and vertical split screen, the A-scope display is only available with the high frequency display. In case of the horizontal split screen, high and low frequency A-scope displays appear.

1. Rotate the [FUNCTION] switch to choose ADVANCE/A-SCOPE to show the PIC ADVANC/A-SCOPE menu.
2. Press the [▼] key to choose A-SCOPE.
3. Press the [+] key twice to choose ON from the setting window.



A-scope selection window

4. Rotate the [FUNCTION] switch to choose EXIT.
5. To turn off the A-scope display, press the [-] key twice to choose OFF at step 3 in this procedure.

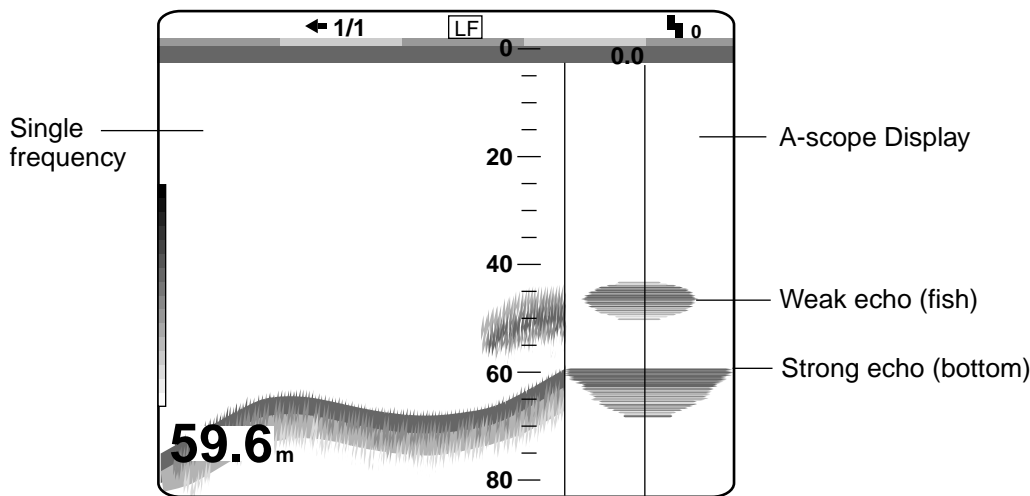

A-scope display

1.16 Suppressing Interference

Interference from other acoustic equipment operating nearby or other electronic equipment on your boat may show itself on the display as shown in the figure below. You may suppress these types of interference with the noise limiter.

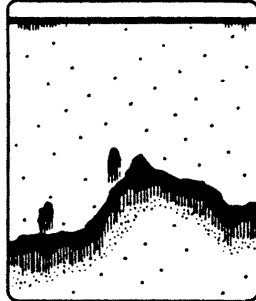

Interference from other sounder

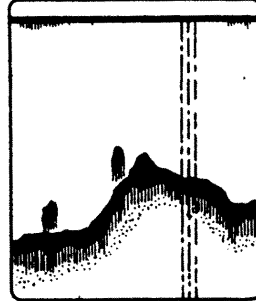

Electrical interference

Interference

1. Rotate the [FUNCTION] switch to choose NL.

NOISE LIMITER	
HF-FREQ ADJ: +0.0%	▼
-10 0 +10	
HF-NOISE LIM: OFF	
LF-FREQ ADJ: +0.0%	▼
-10 0 +10	
LF-NOISE LIM: OFF	
1. Shift frequencies to reject interference. 2. Use LF/HF-NOISE LIM in case interference hasn't been rejected. [-/+]: Change setting [EXIT]: Exit	

The inverted solid triangle shifts with operation of [-] or [+] key.

NL menu

- For the dual display: Go to step 2.
 - For other modes : Go to step 3.
2. Press the [▲] or [▼] key to choose HF•FREQ ADJ or LF•FREQ ADJ, whichever is appropriate.

1. OPERATIONAL OVERVIEW

3. Press the [-] or [+] key to set appropriate value in the setting window so that interference disappears. The setting range for most transducers is -10.0% to +10.0%. However the transducer listed below have different setting ranges.

50 kHz: -10% - +6%

67 kHz /68 kHz: -4% - +10%

107 kHz: -10% - +4%

200 kHz: -9% - +10%

The transducer having the frequency near 54-64 kHz, 112-122 kHz or 171-181 kHz has adjustment limitations. For example, the adjustment range for 66 kHz is -2% - +10%.

If interference is still present, go to step 4, otherwise go to step 7.

4. Press the [▲] or [▼] key to close the setting window.
5. Press the [▼] key to choose HF•NOISE LIM or LF•NOISE LIM, whichever is appropriate.
6. Press the [-] or [+] key to choose the noise rejection setting among N1, N2 and N3. N3 provides the highest level of interference suppression.

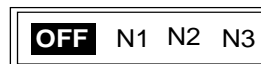

Signal level setting window

7. Rotate the [FUNCTION] switch to choose EXIT.

Note: Turn the noise limiter off when no interference exists, otherwise weak echoes may be missed.

1.17 SHIFT/PROG Key

The [SHIFT/PROG] key is a “soft key” which the operator may program to provide instant access to a function. Simply press the [+] or [-] key to access the function programmed. An appropriate setting window appears. (The illustration below shows the SHIFT window.) Then, press the [+] or [-] key again to select desired setting.

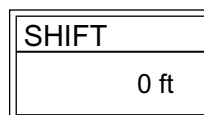

SHIFT window

You can select the soft key function with SHIFT/PROG on the USER menu, and the default setting is “SHIFT.” For further details, see SHIFT/PROG on page 2-15.

2. MENU OPERATION

2.1 Basic Menu Operation

The main menu, consisting of the DISP (display), ALM (alarm), TX/RX, E/S and SYSTEM menus, contains various items which once preset do not require frequent adjustment. The operator may set these items as appropriate to suit operating needs.

1. Rotate the [FUNCTION] switch fully clockwise to choose MENU. The last-used menu among DISP, ALM, TX/RX, ES and SYSTEM appears. The illustration below shows the DISP menu.

Menu titles	DISP	ALM	TX/RX	E/S	SYSTEM
	NO. OF COLORS	:	16		
	HUE	:	STD		
	BACKGROUND	:	BLUE		
	WHITE LINE	:	OFF (OFF, 1~10)		
	DEPTH INFO	:	STD		
	MARKER SELECT	:	VRM		
	ZOOM MARKER	:	ON		
	DISPLAY DATA	:	TIMER		
	SCROLL TIME	:	OFF		
	ECHO STRETCH	:	OFF		
	SMOOTHING-1	:	3 (OFF,1~4)		
	SMOOTHING-2	:	OFF		
Description for selection.	Menu for display setting.				
	[-/+]: Change set, [EXIT]: Exit				

DISP menu

2. Press the [▲] key to choose menu title area.
3. Press the [+] or [-] key to choose menu desired among DISP, ALM, TX/RX, ES and SYSTEM. The menu chosen is highlighted.
4. Press the [▲] or [▼] key to choose item. For example, choose NO. OF COLORS. (Menu help for the item chosen appears at the bottom of the screen.)
5. Press the [-] or [+] key to display the setting window. The illustration below shows the selection window for NO. OF COLORS.

8	16
---	----

Selection window for NO. OF COLORS

2. MENU OPERATION

6. Press the [-] or [+] key to change the setting. For items having several options, a scroll bar (blue) appears. This bar shows the current cursor position in relation to the option range. This bar shifts with operation of the [-] or [+] key.

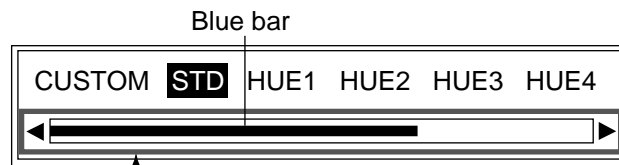

The blue bar shows the current cursor position in relation to the option range.
This bar shifts with operation of [-] or [+] key.

Selection window (for item having several options, for example, HUE)

7. Rotate the [FUNCTION] switch fully counterclockwise to choose EXIT.

2.2 DISP Menu

The DISP menu allows the user to setup up the display as desired.

DISP	ALM	TX/RX	E/S	SYSTEM
NO. OF COLORS	:	16		
HUE	:	STD		
BACKGROUND	:	BLUE		
WHITE LINE	:	OFF (OFF, 1~10)		
DEPTH INFO	:	STD		
MARKER SELECT	:	VRM		
ZOOM MARKER	:	ON		
DISPLAY DATA	:	TIMER		
SCROLL TIME	:	OFF		
ECHO STRETCH	:	OFF		
SMOOTHING-1	:	3 (OFF,1~4)		
SMOOTHING-2	:	OFF		
Menu for display setting.				
[-/+]: Change set, [EXIT]: Exit				

For picture advance speed: 2/1, 3/1, 4/1
 For picture advance speed: 1/16, 1/8, 1/4, 1/2, 1/1

DISP menu

NO. OF COLORS

Chooses eight color or sixteen-color presentation.

HUE

Chooses desired picture color. USER displays the colors programmed by the user. (See page 2-16.) STD is the standard colors used on most FURUNO video sounders. HUE 1-7 provide other picture color arrangements.

BACKGROUND

Chooses background color to black, dark blue, blue, light-blue or white. Note that the background color is fixed when the user color (in HUE above) is chosen.

WHITE LINE

Changes the strongest signal color to white. The higher the setting, the wider the white line. Generally, fish schools on or close to the bottom are displayed on the screen as if they are a small rising from the bottom. This feature can help discriminate bottom fish schools from the bottom.

DEPTH INFO

Changes the size and location of the depth indication.

MARKER SELECT

Chooses the marker function, VRM or WHITE MARKER.

VRM: Measures depth to an echo.

WHITE MARKER: Display a specific echo color in white. This feature is useful for discriminating bottom fish from the bottom.

(White marker operation)

1. After choosing EXIT with the [FUNCTION] switch to close the menu, press the [▲] or [▼] key to show the white marker setting window.

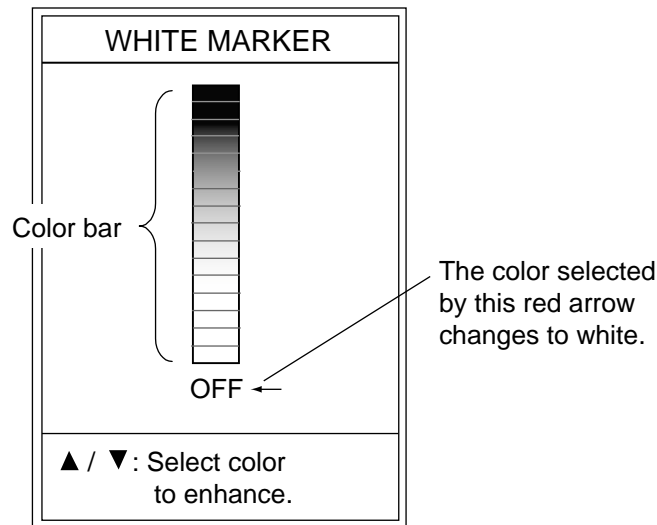

White marker setting window

2. Press the [▲] or [▼] key to choose the echo color which you want to emphasize. The setting window disappears if there is no key operation within five seconds. The color chosen to display in white is shown in white on the color bar.

Note: Before changing from WHITE MARKER to VRM, you must choose OFF in the white marker setting window.

ZOOM MARKER

Turns the zoom marker on/off.

DISPLAY DATA

Chooses the data to display at the left top corner of the screen among OFF, L/L*, TD*, TIMER (Elapsed time from the moment the [MARKER/TLL] key is pressed), GAIN (See note below), R/B* (range and bearing to the waypoint) and COURSE*.

*: Requires navigation device.

Note: The gain setting shown on the display may not agree exactly with GAIN control position. The gain setting shown on the display is the correct value.

SCROLL TIME

Turns the display scroll time on or off. Scroll time, shown at the bottom left corner of the display, shows the amount of time a scan line stays on the screen as it passes from one side of the screen to the other. Time varies with the range and picture advancement speed.

ECHO STRETCH

Displays the strong echoes long though the pulselength setting is short. It is useful for distinguishing individual fish (for example, squid) from plankton.

SMOOTHING-1

This function smoothes echo presentation, and can only be changed when the picture advance speed is set to 1/16, 1/8, 1/4, 1/2 or 1/1. (See page 1-18.) The higher the number, the greater the smoothing. Adjust the setting when echoes appear "spotty."

SMOOTHING-2

This function smoothes the "mosaic-like" echo presentation, and can only be changed when the picture advance speed is set to 2/1, 3/1 or 4/1. (See page 1-18.)

2.3 ALM Menu

The ALM menu sets the bottom, fish and water temperature alarms. To silence the alarm beep, press the [-], [+], [▲] or [▼] key.

BOTTOM ALARM

When your ship comes in the area of the chosen depth, beeps sound and the indication "BTM" flashes at the top right corner to draw your attention.

FISH ALARM

FISH ALARM: Fish echoes of yellow or stronger colors (default setting) trigger the alarm.

BTM-FISH ALARM: When fish echoes come in the area which you set above the bottom, beeps sound and the indication "FISH" flashes at the top right corner of the screen. (Available modes: bottom lock, discrim 1/2, discrim 1/3)

TEMP ALARM

Chooses temperature range which triggers temperature alarm. Audio and visual ("TEMP") alarms are released when water temperature is within the range or out of the range of the preset value. This function requires a water temperature sensor.

2.3.1 Setting the alarm

1. Rotate the [FUNCTION] switch fully clockwise to choose MENU.
2. Press the [▲] key to choose the menu title area.
3. Press the [-] or [+] key to choose ALM to display the ALM menu.

DISP	ALM	TX/RX	E/S	SYSTEM
BOTTOM ALARM : OFF				
ALARM DEPTH : 0 ft]*				
ALARM ZONE : 10 ft]				
FISH ALARM : OFF				
ALARM DEPTH : 0 ft]				
ALARM ZONE : 10 ft]*				
ALARM LEVEL : MID]				
TEMP ALARM : OFF				
TEMP LIMIT : 65.00°F(20~95)]*				
ALARM ZONE : 1.00°F]				
Menu for alarm setting.				
[-/+]: Change set, [EXIT]: Exit				

*: The setting is not available when ALARM is OFF.

ALM (Alarm) menu

4. Press the [▲] or [▼] key to choose the alarm which you want to set.
5. Press the [-] or [+] key to show the alarm setting window.



Bottom alarm



Fish alarm



Temp alarm

Alarm setting window

6. Press the [-] or [+] key to choose the alarm type desired.
7. Press the [▼] key twice to choose ALARM DEPTH (TEMP LIMIT for temp alarm).
8. Press the [-] or [+] key to show the alarm setting window.

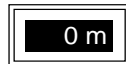

Starting depth setting window (example: bottom alarm)

9. For BOTTOM ALARM and FISH ALARM, press the [-] or [+] key to set the starting point of alarm zone. Alarm marker appears (Depth alarm: green, Fish alarm: white). The starting depth is measured from the transducer surface for BOTTOM ALARM and FISH ALARM, from the bottom for BTM-FISH (bottom fish) alarm.

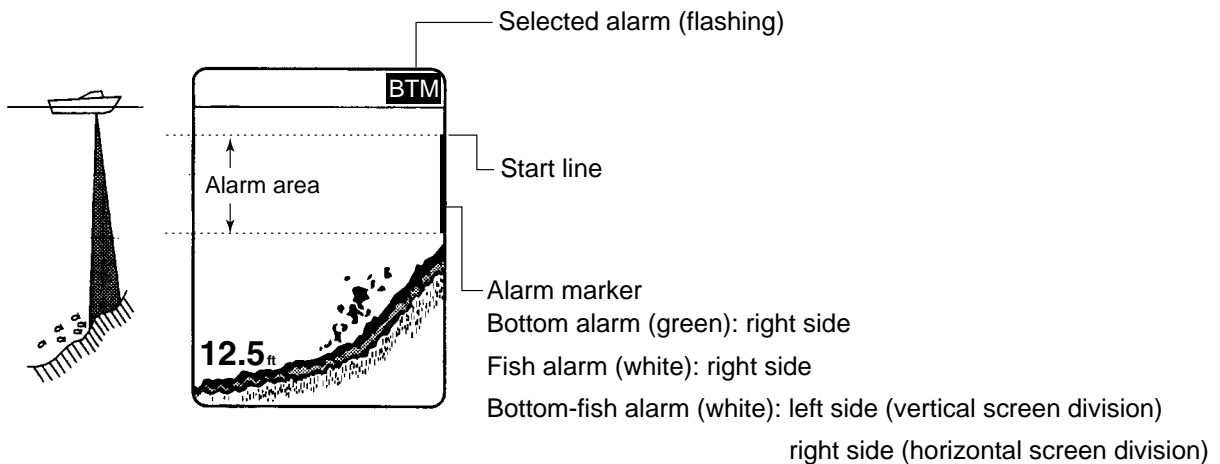

Setting of alarm zone (ex. Bottom alarm)

10. Press the [▼] key to choose ALARM ZONE.
11. Press the [-] or [+] key to show the alarm zone setting window.



Alarm zone setting window (ex. Bottom alarm)

12. Press the [-] or [+] key to set the alarm zone. For depth alarm and temp alarm, go to step 16. To set the fish alarm, go to step 13.
13. Press the [▼] key to choose ALARM LEVEL.
14. Press the [-] or [+] key to show the level setting window.



Level setting window

2. MENU OPERATION

15. Press the [-] or [+] key to set the alarm level.

MIN: Alarm triggered against light-blue or stronger fish echoes.

MID: Alarm triggered against yellow or stronger fish echoes.

MAX: Alarm triggered against red or stronger fish echoes.

16. Rotate the [FUNCTION] switch fully counterclockwise to choose EXIT.

To cancel an alarm, choose OFF at step 6, then rotate the [FUNCTION] switch to choose EXIT.

Note: When multiple alarms are set, the buzzer sounds against the alarm set second (or third).

2.4 TX/RX Menu

The TX/RX menu adjusts pulse repetition rate, STC, gain, RX band, TX pulse and pulselength.

DISP	ALM	TX/RX	E/S	SYSTEM
PRR LEVEL	:	20 (0~20,S)		
<High Frequency>				
STC	:	0 (0~10)		
GAIN ADJ	:	+0		
RX BAND	:	STD		
TX PULSE	:	STD		
PULSE LENGTH	:	0.2 msec (0.2~5.0)*		
<Low Frequency>				
STC	:	0 (0~10)		
GAIN ADJ	:	+0		
RX BAND	:	STD		
TX PULSE	:	STD		
PULSE LENGTH	:	0.2 msec (0.2~5.0)*		
Menu for TX/RX setting.				
[-/+]: Change set, [EXIT]: Exit				

*: The setting is available when MANUAL is selected at TX PULSE.

TX/RX menu

PRR LEVEL

Changes pulse repetition rate. Normally, the highest rate (20) is used. When in shallow waters, second reflection echoes may appear between surface and actual bottom echo. In this case lower the PRR level. The option "S" means the ship's speed dependent mode, where the PRR changes automatically with ship's speed. (Requires speed input.) For further information about the ship's speed dependent mode, see page 1-19.

Note: When using the transducer pair 88F-126H and 28F-24H with the PRR setting of 20, transmitter power will drop slightly on the LF/HF display when the range is within 40 m.

STC (High and Low Frequencies)

Adjusts STC level for the high and low frequencies, and is useful for suppressing surface noise. The setting range is 0 (OFF) to 10. "10" suppresses noise which is up to 5 m distance from the face of the transducer. Turn off the STC when there is no noise on the screen, otherwise weak echoes may be missed.

GAIN ADJ (High and Low Frequencies)

Adjusts gain of receiver unit chosen. Adjust the setting when the GAIN control cannot effectively adjust the gain.

RX BAND (High and Low Frequencies)

Sets amplifier bandwidth of high and low frequency Rx amplifier. When NARROW is chosen, the noise suppression is greater however resolution in shallow water is lower. Normally, set to STD. For increased resolution, choose WIDE.

TX PULSE (High and Low Frequencies)

Sets TX pulselength for high and low frequencies. The available choices are SHORT1, SHORT2, STD, LONG, and MANUAL. Pulselengths except MANUAL automatically change with range and shift.

PULSE LENGTH (High and Low Frequencies)

Sets pulselength, and is effective when TX PULSE setting is MANUAL. Choose a low value for better detection resolution: a high value to increase detection range.

2.5 E/S Menu

The E/S menu sets echo sounder-related options.

DISP	ALM	TX/RX	E/S	SYSTEM
<High Frequency>				
FREQ CHOICE		: 75 kHz		
<Low Frequency>				
FREQ CHOICE		: 50 kHz		
PWR REDUCTION		: OFF		
BOTTOM SEARCH		: AUTO		
BOTTOM LEVEL		: +0(-40 ~+0)		
AUTO MODE		: OFF		
Menu for E/S function setting.				
[-/+]: Change set, [EXIT]: Exit				

E/S menu

FREQ CHOICE

You can change the transmitting frequencies for the following transducers. This function is useful when there is interference from other vessel, or when targeting certain fish species.

50kHz/75kHz transducer

Using the following transducers with 75 kHz provides high-resolution pictures:

- 50B-6
- 50/200-1T (50kHz)
- 50/200-1ST(50 kHz)
- 50B-9
- 50B-12

Note 1: When using above transducers on 75 kHz the transmission line (zero line) may be longer than normal.

Note 2: 50 kHz and 75 kHz pictures are displayed on the dual frequency display with connection of one of the above-mentioned transducers. However, the actual picture is shown only for the port where the transducer is connected.

PWR REDUCTION

Reduces the power output on high and low frequencies. “<P/R>” appears at the bottom of the screen when turned on. When switching from OFF to ON, it takes several seconds to reduce power.

BOTTOM SEARCH

On the dual-frequency display, choose transducer which is to measure depth. The choices are AUTO, low frequency and high frequency. “AUTO” gives priority to high frequency transducer having greatest accuracy.

BOTTOM LEVEL

When the bottom depth readout is unstable, use this feature to stabilize it. The setting range is -40 to 0.

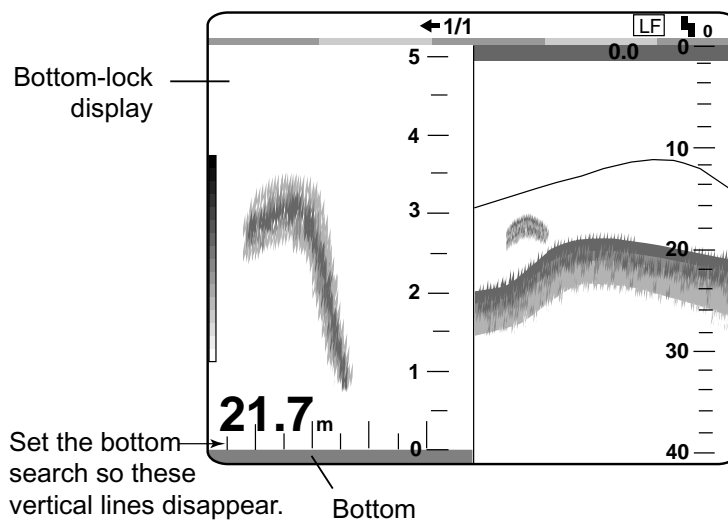

How to adjust bottom level

If this setting value is too small, fish echoes may be regarded as bottom, which causes unstable depth readout.

AUTO MODE

Turns on/off the auto mode.

- OFF: Turns off the auto mode. Gain, range and clutter may be adjusted manually.
- CRUISING: Suppresses weak echoes to emphasize bottom echoes clearly. Use this setting when going to a fishing ground.
- FISHING: Displays weak echoes clearly. Use this setting for fishing.

In the auto mode, gain, display range and clutter are automatically adjusted. Gain is automatically adjusted so the bottom echo is painted in reddish brown. (If the gain appears to be too strong, it can be offset on the TX/RX menu with “GAIN ADJ.”) Display range is automatically adjusted to show the bottom echo on the lower 1/2 of the screen. Clutter is automatically adjusted to suppress weak echoes such as sediment in the water and plankton.

2.6 USER Menu



The USER menu sets up the user displays, user color and user clutter, and programs the [SHIFT/PROG] key. This menu can be shown by placing the [FUNCTION] switch in the "PROG" position.

USER	
USER-1/2	
<USER-1>	
NAV DATA DISP	: OFF
NAV DATA MODE	: ALPHANUMERIC
<USER-2>	
NAV DATA DISP	: OFF
NAV DATA MODE	: ALPHANUMERIC
SHIFT/PROG KEY	: SHIFT
USER COLOR SETTING	
USER CLUTTER SETTING	
Menu for user-preset mode setting.	
[+]: Go to setting [EXIT]: Exit	

USER menu

USER-1/2

Customizes the user displays.

USER -1/2	
<USER-1>	
SCREEN LAYOUT	: 
DISP MODE	: [LF]+[HF]+[MIX]
ZOOM MODE	: BOTTOM ZOOM *
TARGET ECHO	: NORMAL
<USER-2>	
SCREEN LAYOUT	: 
DISP MODE	: [LF]Zm/Nor+[HF]Zm/Nor
ZOOM MODE	: BOTTOM ZOOM
TARGET ECHO	: NORMAL
Select screen layout.	
[-/+]: Change set, [EXIT]: Exit	

* = The setting is available when Zm (Zoom) is selected at the DISP MODE field.

USER-1/2 menu

SCREEN LAYOUT

Chooses the screen division layout among the patterns shown below.

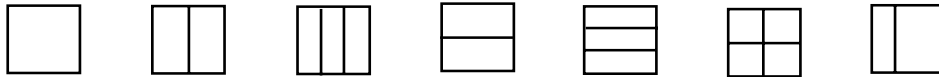

The default settings are as follows:

USER-1: ([LF]+[HF] +[MIX])

USER-2: ([LF]Zm/Nor+[HF]Zm/Nor)

DISP MODE

Chooses the picture to display in respective screen layout.

[HF]:Normal
[LF]:Normal
[HF]:Zoom
[LF]:Zoom
[MIX]:Normal

[LF]+[HF]:Zm/Nor
 [LF]:Zm/Nor+[HF]
 [LF]+[HF]+[MIX]

[HF]:Zm/Nor
 [LF]:Zm/Nor
 [LF]+[HF]
 [LF]:Zm+[HF]:Zm
[HF]+[MIX]
[LF]+[MIX]

[LF]:Zm/Nor+[HF]:Zm/Nor

HF: high frequency LF: low frequency
NOR: normal ZM: zoom
MIX: mix

ZOOM MODE

Chooses the zoom mode to use.

BOTTOM LOCK BOTTOM ZOOM MARKER ZOOM DISCRIM-1/2 DISCRIM-1/3

Zoom mode choices

TARGET ECHO

Chooses the target echo from normal, surface, squid and deep sea. For details, see page 3-10.

NORMAL SURFACE SQUID DEEP SEA

Target echo choices

NAV DATA DISP

Nav data may be displayed at the left or right half of the screen, or turned off.

NAV DATA MODE

Three nav data displays are available: alphanumeric, graphic1 and graphic2.

ALPHANUMERIC

The alphanumeric display provides position in latitude and longitude, course, speed, depth, temperature, and range, bearing and cross-track error to the destination waypoint. Appropriate sensors are required to show data other than depth. If desired, you may enlarge one indication on one half of the screen. Circumscribe the indication to enlarge by operating the [▲] or [▼] key, then press the [+] key. To restore the full nav data display, press the [-] key.

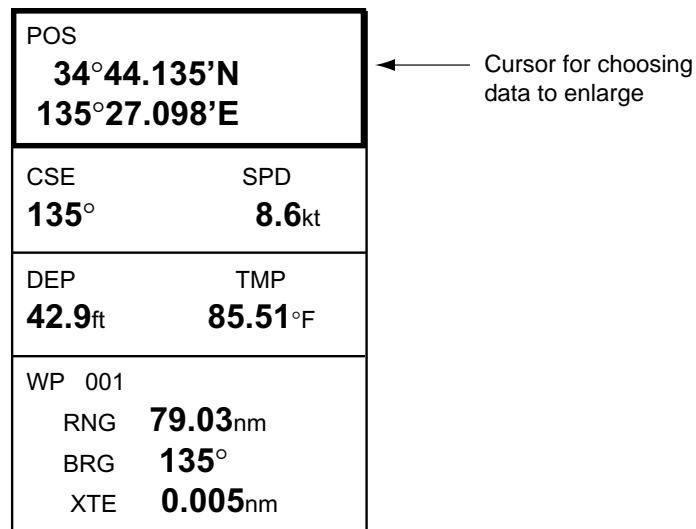

Nav data display

GRAPHIC1

The GRAPHIC1 display mainly provides steering information. Appropriate sensors are required.

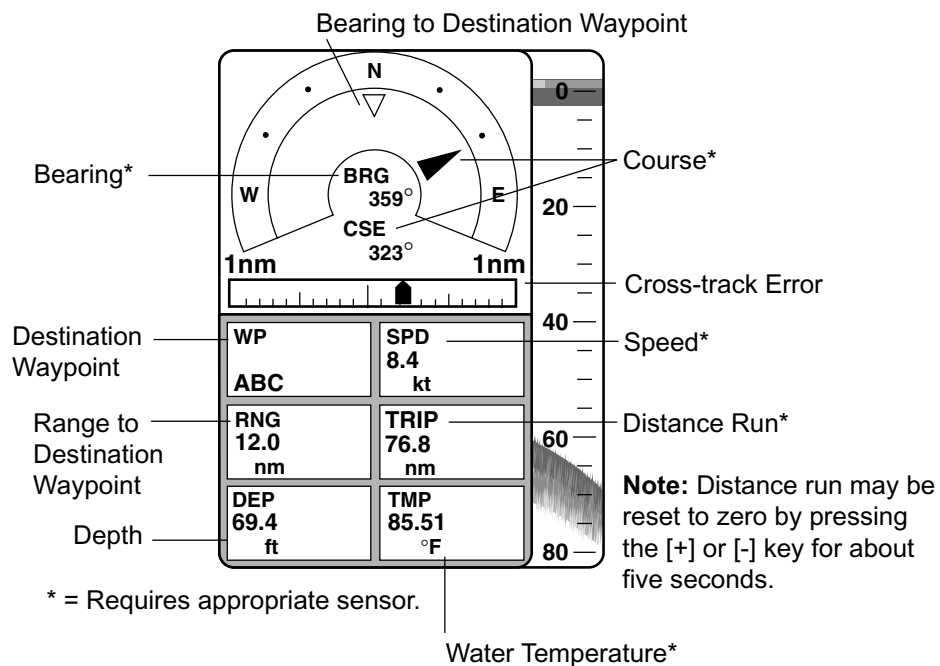

Graphic1 display

GRAPHIC2

The GRAPHIC 2 display provides a speedometer together with steering information. Appropriate sensors are required.

Distance run since power was turned on

Note: Distance run may be reset to zero by pressing the [+] or [-] key for about five seconds.

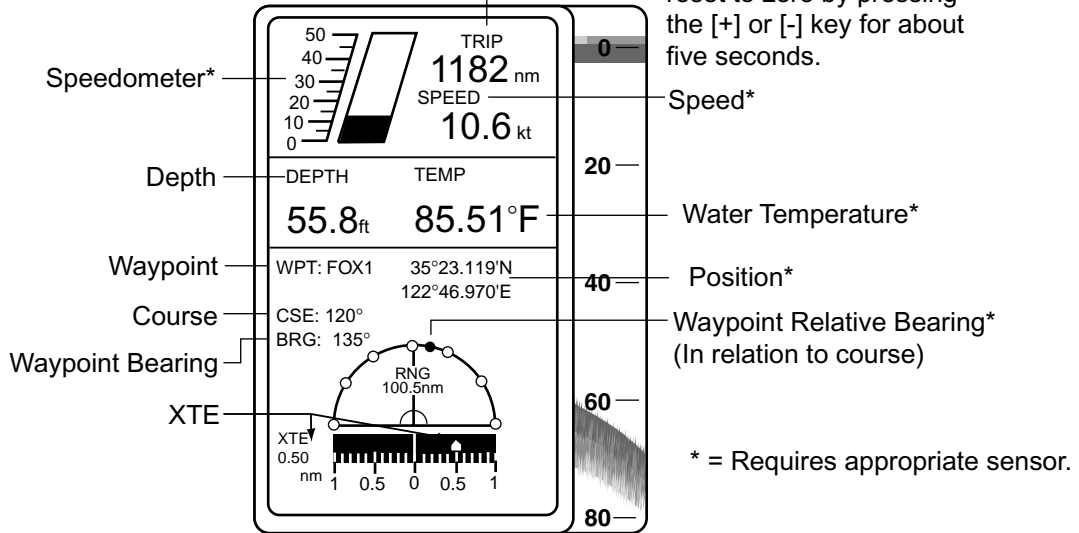

Graphic2 display

SHIFT/PROG KEY

Chooses the function of the [SHIFT/PROG] key. The choices are shift, picture advance, signal level, hue, white line, PRR level, bottom level, A-scope, auto shift and auto mode.

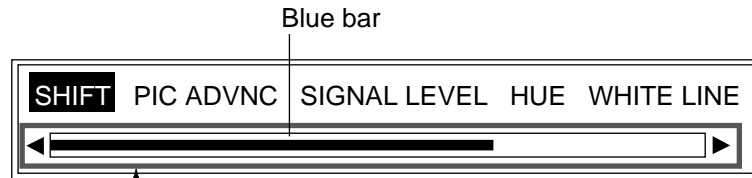

The blue bar shows the current cursor position in relation to the option range.
This bar shifts with operation of [-] or [+] key.

SHIFT/PROG soft key program choices

USER COLOR SETTING

In addition to the standard and factory-programmed color sets, the user may set and store display colors as desired.

USER COLOR SETTING		
COLOR NO.	: BKGD	
RED	: 0 (0~15)	<input type="text"/>
GREEN	: 2	<input type="text"/>
BLUE	: 9	<input type="text"/>
DEFAULT	: NO	
CUSTOM	: NO	
Color setting for 16-color presentation.		
[-/+]: Change set, [EXIT]: Exit		

USER COLOR SETTING menu

1. Press the [-] or [+] key to show the color setting window. (In case of eight colors, color is 1-6.)

BKGD	ECHO1	ECHO2	ECHO3	ECHO4	ECHO5	ECHO6	ECHO7
							

Color setting window (16 colors)

2. Press the [-] or [+] key to select the color to change.

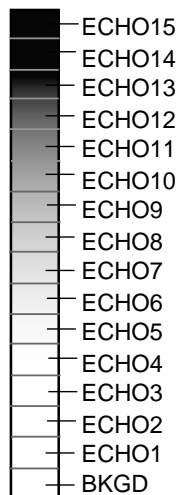

Color bar (for 16 colors)

3. Press the [▲] or [▼] key to close the color setting window.
4. Press the [▼] key to select RED, GREEN or BLUE (level).

- Press the [-] or [+] key to show the level setting window.



Level setting window

- Press the [-] or [+] key to select color strength. The higher the number, the darker the color.
- Press the [▲] or [▼] key to close the level setting window.
- Do steps 1-7 to set another color.
- To use custom colors, select YES at CUSTOM.
- To return to original color, select YES at DEFAULT.

USER CLUTTER SETTING

The USER CLUTTER SETTING menu lets you emphasize weak to medium strength echoes.

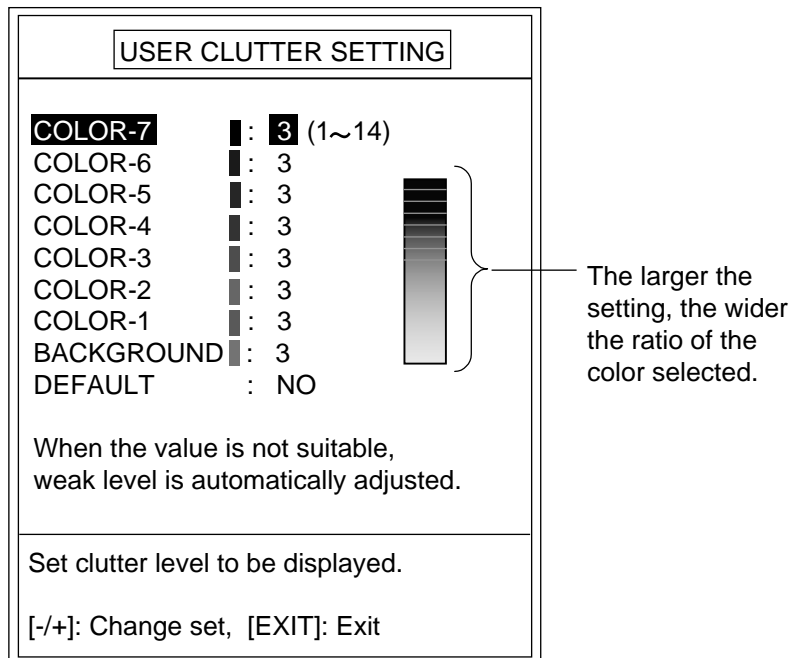

USER CLUTTER SETTING menu

- Press the [▲] or [▼] key to select color or background to change. COLOR-7 is the strongest color.
- Press the [-] or [+] key to show the setting window.



Setting window

2. MENU OPERATION

3. Press the [-] or [+] key to set the level (1-14).

If...	Then...
you want to emphasize COLOR-7 (reddish-brown, red)	COLOR-7, COLOR-6: set large value. COLOR-5 to COLOR-1: Set small value.
you want to emphasize middle color (yellow, green)	COLOR-7 to COLOR-5: Set small value. COLOR-4 and COLOR-3: Set large value. COLOR-2 and COLOR-1: Set small value.
you want to remove the weakest color	COLOR-1: Set small value.

4. Press the [▲] or [▼] key to close the setting window.
5. Repeat steps 1 through 4 to set another color.
6. To use custom clutter settings, set the [FUNCTION] switch in the CLUTTER position, then select CUSTOM from HF CURVE (LF CURVE).

To return to default settings, select YES at DEFAULT.

3. SYSTEM MENU

3.1 SYSTEM Menu Operation

1. Rotate the [FUNCTION] switch fully clockwise to select MENU.
2. Press the [▲] key to select the menu title area.
3. Press the [+] key to choose SYSTEM to show the SYSTEM menu.

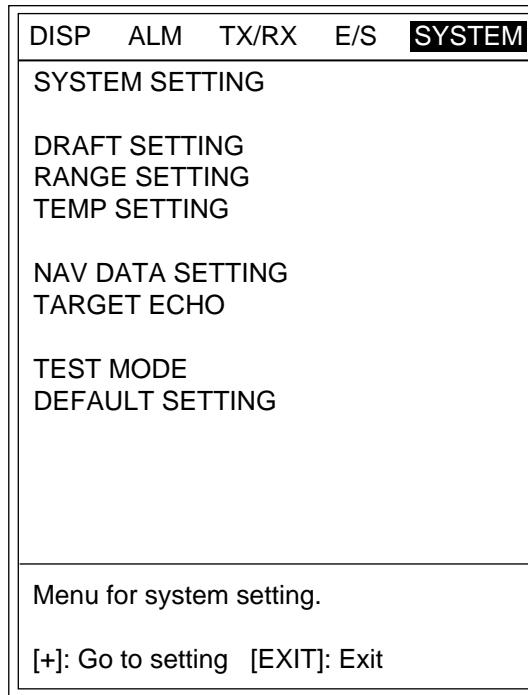

System menu

4. Press the [▲] or [▼] key to select the item which you want to set.
5. Press the [+] key to show the sub menu.
6. Rotate the [FUNCTION] switch fully counterclockwise to select EXIT.

3.2 SYSTEM SETTING Menu

The SYSTEM SETTING menu mainly sets picture layout options.

DISP	ALM	TX/RX	E/S	SYSTEM
SYSTEM SETTING				
PICT ADV DIR		: LEFT		
DISP DIVISION		: <input type="checkbox"/>		
DEPTH SCALE		: RIGHT		
DEPTH UNIT		: ft		
FREE SHIFT		: OFF		
AUTO SHIFT		: OFF		
ZOOM MODE		: BOTTOM LOCK		
LANGUAGE		: ENGLISH		
Select picture scrolling direction.				
[-/+]: Change set, [EXIT]: Exit				

SYSTEM SETTING menu

PICT ADV DIR

Chooses picture advance direction: right or left which advances the picture in both right and left directions from the screen center.

DISP DIVISION

Sets display division for the dual frequency picture. , vertical; , horizontal.

DEPTH SCALE

Chooses where to position the depth scale; right, center or off.

DEPTH UNIT

Chooses unit of depth measurement; meters, feet, fathoms, hiro (Japanese), passi/braza. Note that the Japanese characters for hiro appear when using hiro.

FREE SHIFT

Sets shift value independently for each range (ON) or commonly for all ranges (OFF).

AUTO SHIFT

Turns automatic depth shift on or off. The automatic shift function automatically locates the bottom trace on the lower half of the screen; the range window jumps up where the bottom trace rises over the center of the screen and jumps down when it reaches the bottom of the screen. AUTO appears at the top right corner of the screen when the auto shift function is on. Note that the [+] and [-] keys are inoperative when the automatic shift function is turned on.

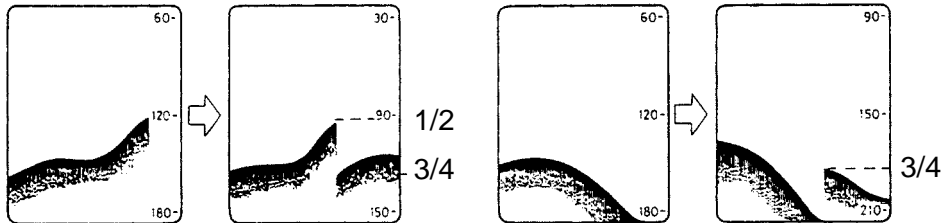

Range changes automatically to locate the bottom on the lower half of screen.

The equipment shifts to a deeper range when the bottom comes to the lower edge of the depth scale.

Automatic shift concept

ZOOM MODE

Chooses the zoom mode for the ZOOM position of the [FUNCTION] switch. The choices are bottom lock, bottom zoom, marker zoom, discrimination-1/2 and discrimination-1/3.

LANGUAGE

Chooses the language: ENGLISH or other languages. To switch language, select language desired, then rotate the [FUNCTION] switch fully counterclockwise to select EXIT.

3.3 DRAFT SETTING Menu

The DRAFT SETTING menu sets draft value, when you require depth below the surface.

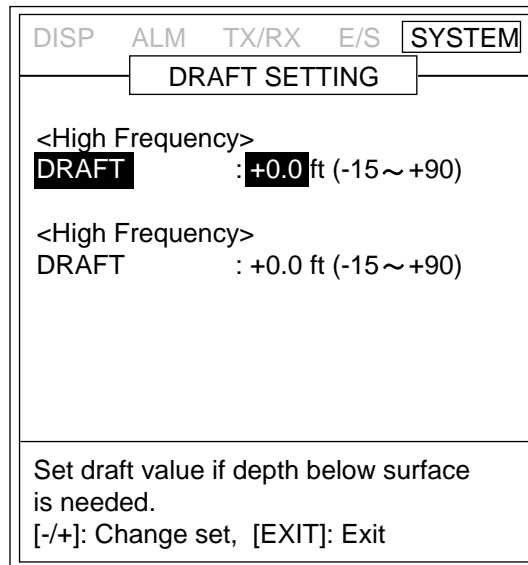

DRAFT SETTING menu

DRAFT

Sets draft depth for low and high frequencies.

3.4 RANGE SETTING Menu

The RANGE SETTING menu presets the range chosen with the [RANGE] control.

DISP	ALM	TX/RX	E/S	SYSTEM
RANGE SETTING				
RANGE1	:	30	ft	(16 ~6000)
RANGE2	:	60	ft	
RANGE3	:	120	ft	
RANGE4	:	250	ft	
RANGE5	:	500	ft	
RANGE6	:	1000	ft	
RANGE7	:	1600	ft	
RANGE8	:	3000	ft	
M/Z RANGE	:	16	ft	(16~ 600)
B/L RANGE	:	16	ft	
SPLIT RANGE: OFF				
Set preset range scales.				
[-/+]: Change set, [EXIT]: Exit				

RANGE SETTING menu

RANGE1-RANGE8

Presets basic ranges for the [RANGE] switch. Ranges must be set from shallow to deep, and a range may not be lower than a preceding one. (Setting ranges: 5-2000 m, 16-6000 ft, 2-1200 fa, 4-1600 hiro, 3-1200 P/B)

M/Z RANGE

Sets display range of marker zoom and bottom zoom pictures. (Setting ranges: 5-200 m, 16-600 ft, 2-120 fa, 4-160 hiro, 3-120 P/B)

Note: For the vertical split screen, halve the above values.

B/L RANGE

Sets display range of bottom-lock, discrim-1/2, discrim-1/3 picture. (5-200 m, 16-600 ft, 2-120 fa, 4-160 hiro, 3-120 P/B)

Note: For the vertical split screen, halve the above values.

SPLIT RANGE

Select ON to set range for low frequency and high frequency individually.

1. Rotate the [RANGE] switch to show RANGE (LF or HF) window.

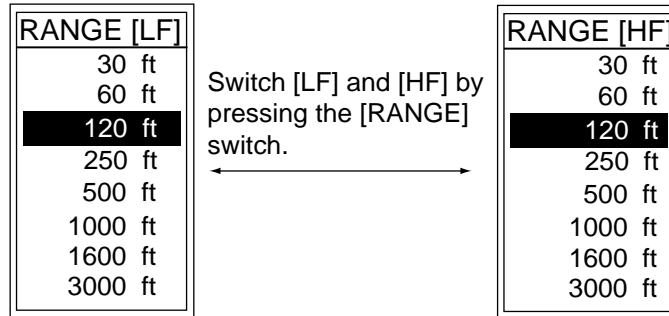

Range window

2. Press the [RANGE] switch within five seconds to display the RANGE (LF) window or RANGE (HF) window whichever desired.
3. Rotate the [RANGE] switch to select the range desired.

3.5 TEMP SETTING Menu

The TEMP SETTING menu sets up the water temperature sensor (FURUNO-supplied sensor only).

DISP	ALM	TX/RX	E/S	SYSTEM
TEMP SETTING				
TEMP UNIT : °F				
TEMP INPUT : SENSOR				
TEMP ADJUST : +0.00°F (-20~ +20)				
TEMP OUTPUT : ON				
TEMP READOUT: ON				
TEMP GRAPH : OFF				
TEMP COLOR : STD				
Select temperature unit.				
[-/+]: Change set, [EXIT]: Exit				

TEMP SETTING menu

TEMP UNIT

Chooses unit of temperature measure, Celsius or Fahrenheit.

TEMP INPUT

Chooses source of water temperature data; sensor (FURUNO), or NMEA.

TEMP ADJUST

Offsets water temperature indication to improve accuracy. Effective only for FURUNO-supplied water temperature sensor.

TEMP OUTPUT

Turn on/off water temperature data output.

TEMP READOUT

Turns on/off water temperature indication.

TEMP GRAPH

Turns on/off water temperature graph and chooses graph scale.

OFF: No water temperature graph

TEMP COLOR

Chooses the color of the temperature graph (standard, white, red, black, yellow).

Note: Standard means the fifth color from the bottom of the color bar, including background color in 16-color display; third color in 8-color display. Yellow means tenth (8-color display: sixth) color from the bottom of the color bar.

3.6 NAV DATA SETTING Menu

The NAV DATA SETTING menu chooses source of position and heading data.

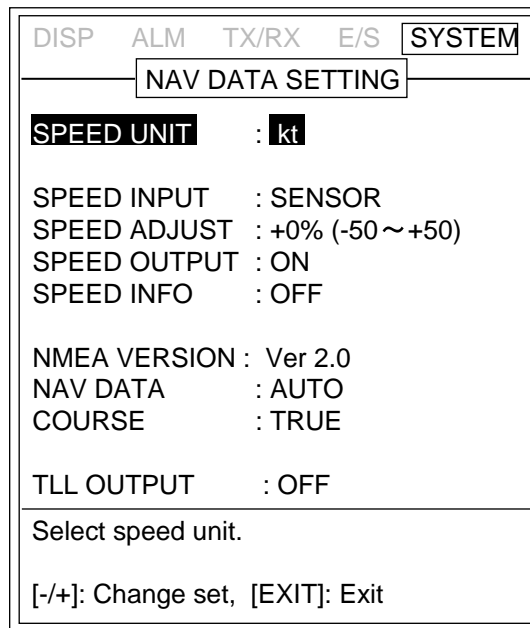

NAV DATA SETTING menu

SPEED UNIT

Chooses unit of speed measurement from knot, kilometer and statute miles-per-hour.

SPEED INPUT

Chooses source of speed data, sensor or NMEA.

SPEED ADJUST

Further refines speed data accuracy.

SPEED OUTPUT

Turns speed data output on/off.

NMEA VERSION

Chooses NMEA version of external navigator; Ver 1.5, Ver 2.0, Ver. 3.0 or SPECIAL. If you are not sure of version number try both and select which one successfully receives data. SPECIAL outputs the depth data at the rate of 600 bps.

NAV DATA

Chooses source of navigation data (NMEA talker); GPS, Loran C, Loran A, Decca, DR or AUTO. Select AUTO when more than one talker data is input. The order of priority is GPS, Loran C, Loran A, Decca, DR.

COURSE

Chooses heading reference (for heading data output from navigator); TRUE or MAG (magnetic bearing).

TLL OUTPUT

Enables/disables output of L/L position to a navigation plotter when the [MARKER/TLL] key is pressed.

3.7 TARGET ECHO Menu

The TARGET ECHO menu sets fishing objective. Four choices are available: NORMAL, SURFACE, SQUID and DEEP SEA.

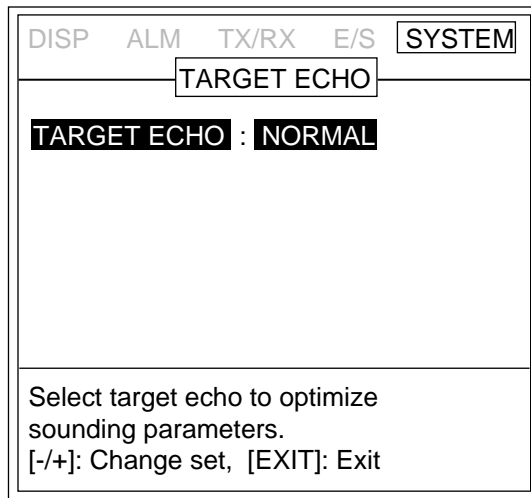

TARGET ECHO menu

TARGET ECHO

Sets up the equipment according to fishing objective

NORMAL: For general fishing.

SURFACE: For detecting surface fish. Pulse repetition rate is higher than "NORMAL" on 1 kW and 2 kW transducers (only those transducers registered on the menu).

SQUID: For detecting squid and other individual fish. The items below are automatically set as follows:

TX pulselength: Short 1

Echo stretch: ON

Smoothing-1: OFF

DEEP SEA: Same as GENERAL.

4. INTERPRETING THE DISPLAY

This section provides, using typical examples, the information necessary for interpreting the display.

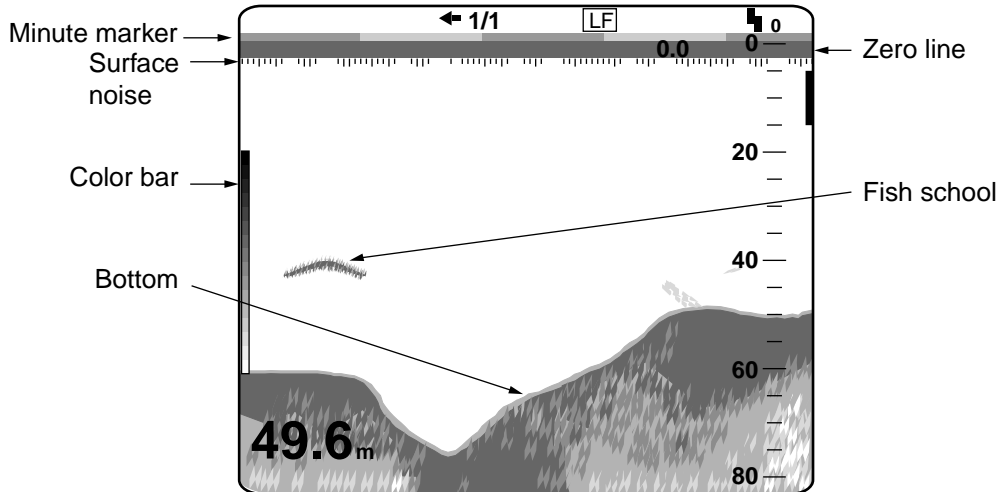

Typical display

Minute Marker: The minute marker displays a minute worth of time with two colored bars, each bar 30 seconds in time. It is useful for estimating elapsed time.

4.1 Color Bar

The color bar shows the relation between echo intensity and echo color on the screen. The top color (reddish-brown) is the strongest color and the lower colors the weakest. The bar can be used as a reference to estimate density of a fish school, fish species and hardness of the bottom. The background color can be selected on the menu screen.

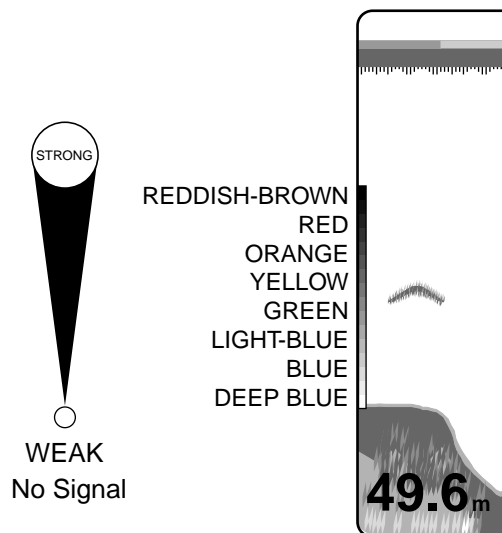

Color bar

4.2 Zero Line

The zero line represents the transducer's position. It moves off the screen when a shifted range is used, or is shown at draft depth when ship's draft is entered.

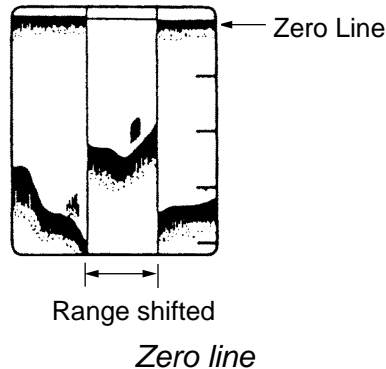

4.3 Bottom Echoes

Bottom echoes are normally strongest and displayed in reddish-brown or red, but colors and width will vary with bottom material, depth, sea condition, installation, frequency, pulselength and sensitivity.

A hard and rough bottom appears with a longer tail because it reflects more of the ultrasonic pulse. Because of their stronger return, shallow echoes appear wider than deep ones even when all bottom conditions are equal. Also, a longer bottom tail appears on slopes because of the difference in traveling time at both edges of the beam angle. In the rugged bottom, echoes are reflected on many different planes, overlapping to present a 3D effect.

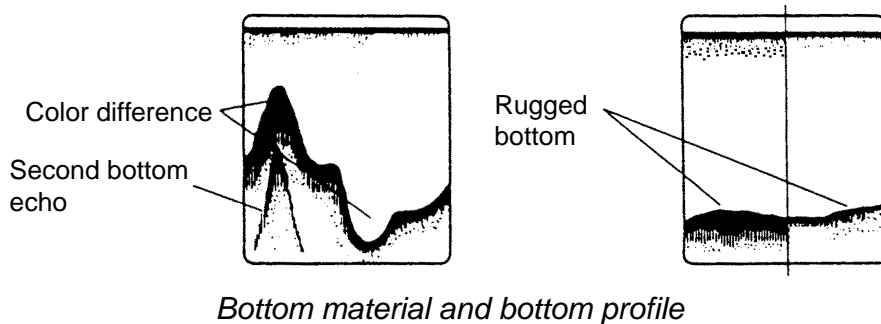

The nature of the bottom is known from the intensity and length of the bottom tail. Generally, when observing the bottom nature, the lower sounding frequency is used, the pulselength is set to long, and the gain setting is not disturbed. In the hard and craggy bottom, the bottom appears more reddish and with a long tail. However, the bottom with sediment may give a short tail if a low frequency sounding is used.

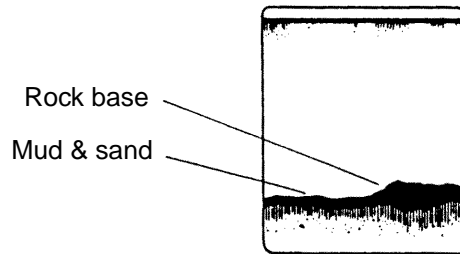

Bottom nature

4.4 Fish School Echoes

Fish quantity can be estimated to a certain extent from fish echoes on the screen if fish school size and fish school density are kept in mind.

Usually the size of fish echoes on the screen is proportional to the actual size of the fish school. However, if two fish echoes appear at different depths with the same size, the fish school at shallower depth is smaller because the ultrasonic beam widens as it propagates and a fish school in deep water is displayed larger.

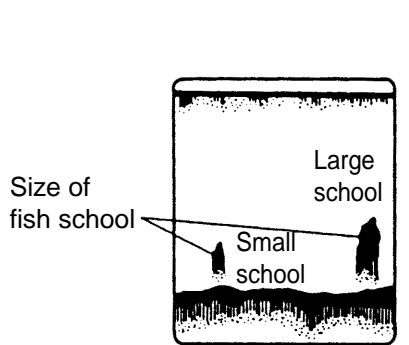

Fish school size

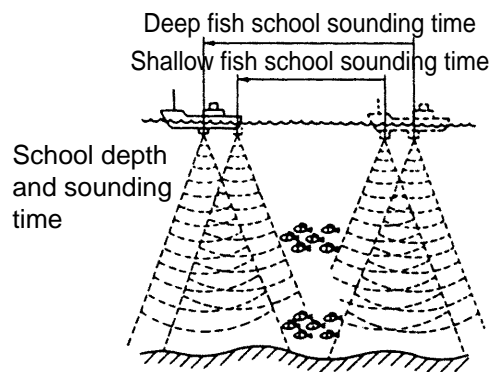

Difference of fish school sounding times

4. INTERPRETING THE DISPLAY

If two fish schools appear with the same color at different depths, the one in deeper water is denser because the ultrasonic wave attenuates as it propagates and the fish school in deep water tends to be displayed in a weaker color.

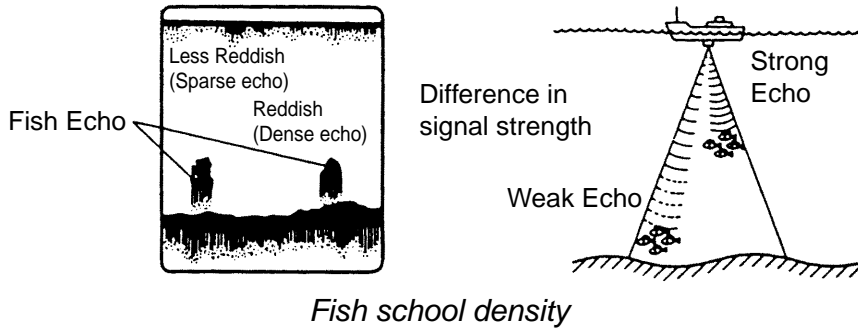

4.5 Other Echoes

4.5.1 Plankton

A plankton layer, a likely place to find fish, is displayed in green or blue dots. It usually descends in the day and rises at night.

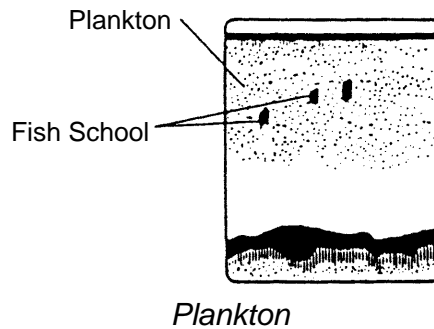

4.5.2 Current rip

A current rip develops when two ocean currents of different speeds, directions and water temperatures meet. Its on-screen appearance is as shown below.

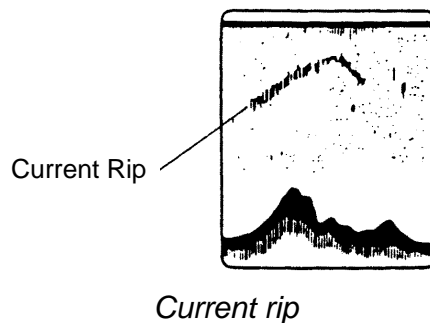

4.5.3 Surface noise

When the sea is rough or the ship passes over a wake, surface noise may appear at the top of the screen. It can be suppressed with the CLUTTER function.

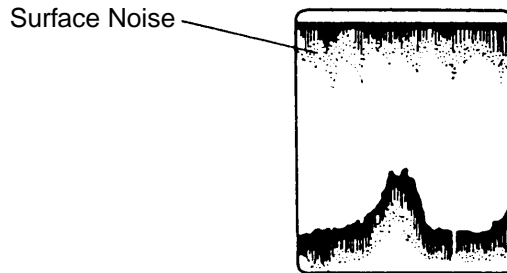

Surface noise

4.5.4 Aerated water

When the sea is rough or the ship makes a quick turn, gaps in the bottom echo on the screen may appear. This is caused by air bubbles which block propagation of the sound wave. Generally low frequency ultrasonic waves are interrupted more easily than high ones.

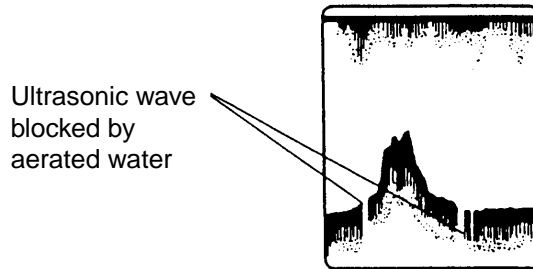

Aerated water

4.5.5 False image

Every time the ultrasonic pulse is transmitted, some radiation escapes on each side of the beam, called "side lobes." Echoes from side lobes show on the display as false images as below.

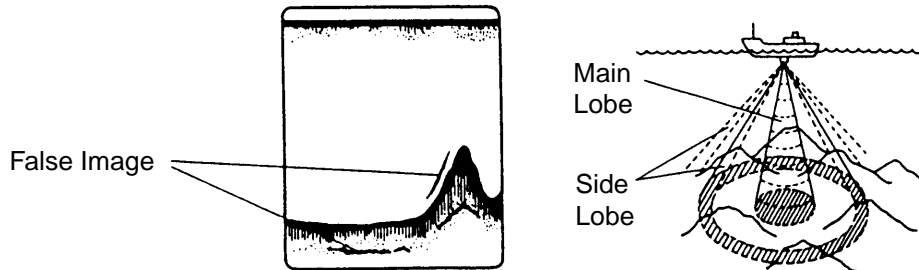

False image

4. INTERPRETING THE DISPLAY

This page is intentionally left blank.

5. MAINTENANCE, TROUBLESHOOTING



5.1 Maintenance

Regular maintenance is important for continued performance. Important points to be checked from time to time are shown below.

Maintenance program

Check point	Action	Interval
Transducer cable	If conductors are exposed, replace cable.	Monthly
Power cable plug, transducer cable plug	If loosened, secure tightly.	Monthly
Grounding	If corroded, clean.	Monthly
Ship's mains voltage	If out of ratings, correct problem.	Monthly
Display unit cleanliness	Dust or dirt may be removed with a soft cloth. Water-diluted mild detergent may be used if desired. DO NOT use chemical cleaners to clean the display unit; they may remove paint and markings. Use special care when cleaning the LCD, since it scratches easily.	Monthly
Transducer cleanliness	Marine life on the transducer will result in a gradual decrease in sensitivity. Check the transducer face each time the boat is dry-docked. Carefully remove any marine life with piece of wood or fine sandpaper.	At dry-dock

5.2 Fuse Replacement

A 5A fuse (type: FGBO-A 5A AC125V) in the power cable protects the equipment against overcurrent, reverse polarity of the ship's mains and internal fault. If the fuse blows find the cause before replacing it. Contact your dealer about replacement. (A 7A fuse (type: FGMB 7A 125V) also is contained inside the display unit. Contact your dealer about its replacement.)



5.3 Troubleshooting

This section provides simple troubleshooting procedures which the user may follow to restore normal operation.

Troubleshooting

If...	Then...
there are no echoes but the depth scale appears	<ul style="list-style-type: none"> • check if the transducer is properly connected.
there is no zero line or zero line is not in correct position	<ul style="list-style-type: none"> • check if the range shifted. (Zero line does not appear when the range is shifted.) • press the [-] key so as the scale starts from 0.
you suspect poor or low sensitivity	<ul style="list-style-type: none"> • check that the [GAIN] control is properly set.
the bottom is traced in zigzag pattern or you experience occasional loss of echo	<ul style="list-style-type: none"> • the sea may be rough. Bottom is traced zigzag when the sea is rough. • own boat may have passed over other boat's wake, which blocks propagation of sound wave.
there is no depth readout	<ul style="list-style-type: none"> • check to see if bottom is present on the normal picture range. • check if bottom echo is painted in red, reddish-brown.
automatic shift is inoperative	<ul style="list-style-type: none"> • check if bottom echo is painted in red, reddish-brown.
noise appear intermittently	<ul style="list-style-type: none"> • check if the cables of pulse generating equipment are near the equipment.
there is noise and interference	<ul style="list-style-type: none"> • check that GAIN and CLUTTER are properly adjusted. • check the setting of the noise limiter. • check the equipment's ground.

5.4 Diagnostic Test

The diagnostic test checks the equipment for proper operation.

1. Rotate the [FUNCTION] switch fully clockwise to select MENU.
2. Press the [▲] key to select the menu title area at the top of screen.
3. Press the [+] key to select SYSTEM.
4. Press the [▲] or [▼] key to select TEST MODE.
5. Press the [+] key to open the TEST menu.

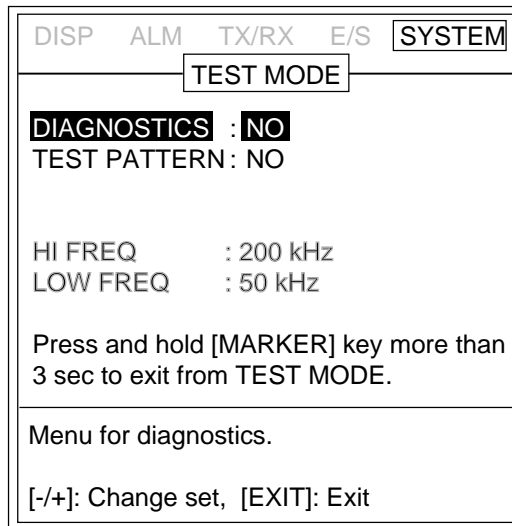

Test menu

6. Press the [+] key twice to select YES in the setting window.



Test setting window

7. The ROM, SRAM, DRAM and NMEA check results appear. Water temperature and speed also appear if appropriate sensor is connected.

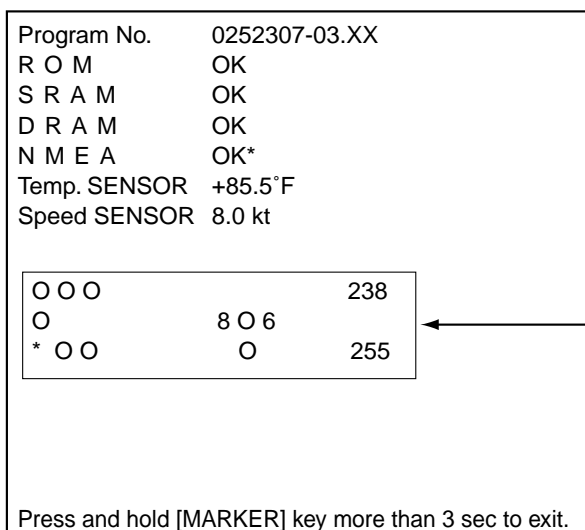

ROM, SRAM, DRAM and NMEA test results are shown as OK or NG (No Good).

Panel window
For testing controls.
See next page.

XX: Version No.

*: Requires special cable to check.

Diagnostic test results

5.4.1 Panel Test

The “panel window” at the bottom of the diagnostics display is used to check keys and controls.

1. Press any key except the [PWR] key. The pressed key’s on-screen location changes from 0 to 1 when the key is pressed.
2. Operate each control. The figure on the screen changes as below.
 - [FUNCTION]: 1 to 8
 - [RANGE]: 0 to 20
 - [MODE]: 1 to 7
 - [GAIN]: 0 to 255
3. To quit the diagnostic test, press the [MARKER/TLL] key more than three seconds to return to the SYSTEM menu, then rotate the FUNCTION switch fully counterclockwise to select EXIT.

5.5 Test Pattern

The test pattern tests for proper display of colors.

1. Rotate the [FUNCTION] switch fully clockwise to select MENU.
2. Press the [▲] key to select the menu title area at the top of the screen.
3. Press the [+] key to select SYSTEM.
4. Press the [▲] or [▼] key to select TEST MODE.
5. Press the [+] key.
6. Press the [+] key to select TEST PATTERN.
7. Press the [+] key twice to select YES in the dialog box.



Test pattern selection dialog box

8. Press the [+] key successively to change the test pattern, in the sequence below.

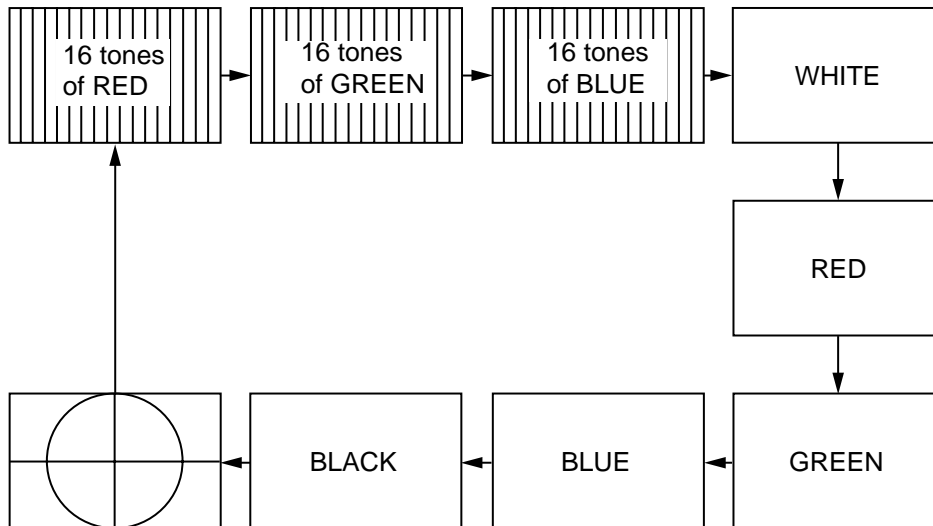

Test pattern sequence

9. Press the [MARKER/TLL] key more than three seconds to return to the SYSTEM menu.
10. Rotate the [FUNCTION] switch fully counterclockwise to select EXIT.

5.6 Restoring Default Settings

All menu options can be restored to their default settings. For your reference all default settings are shown in the menu tree at the back of this manual.

Note: User color setting, language, target echo setting and user clutter setting are not disturbed.

1. Rotate the [FUNCTION] switch fully clockwise to select MENU.
2. Press the [▲] key to select the menu titles at the top of the menu.
3. Press the [+] key to select SYSTEM.
4. Press the [▼] key to select DEFAULT SETTING.
5. Press the [+] key to show the DEFAULT SETTING menu.

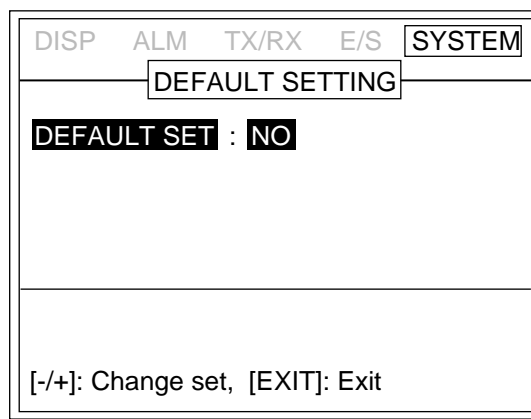

Default setting menu

6. Press the [+] key twice to select YES in the selection window.



Default setting selection window

7. A beep sounds while the memory is being cleared.
8. After the beep stops, rotate the [FUNCTION] switch fully counterclockwise to select EXIT.

APPENDIX

Menu Tree

[FUNCTION] switch

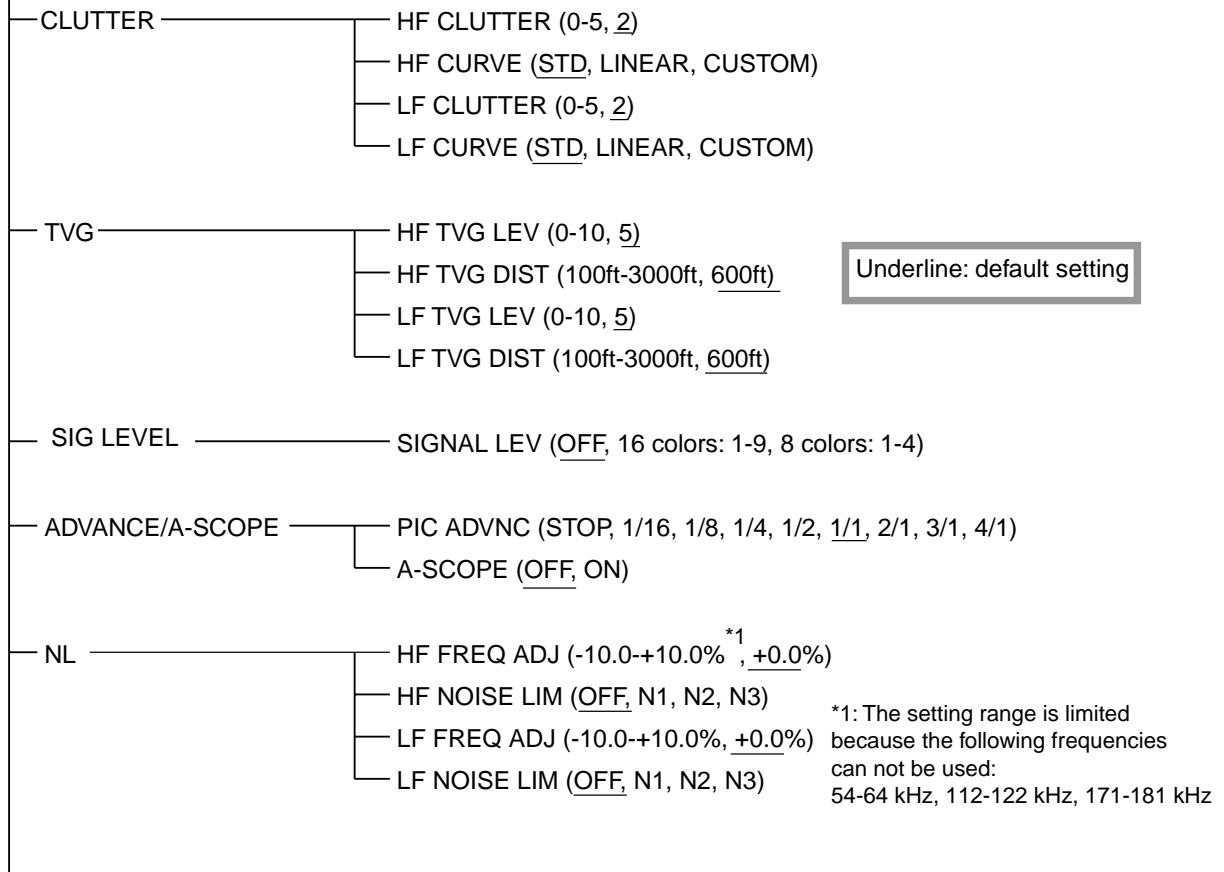

(Continued on the next page)

(Continued from previous page)

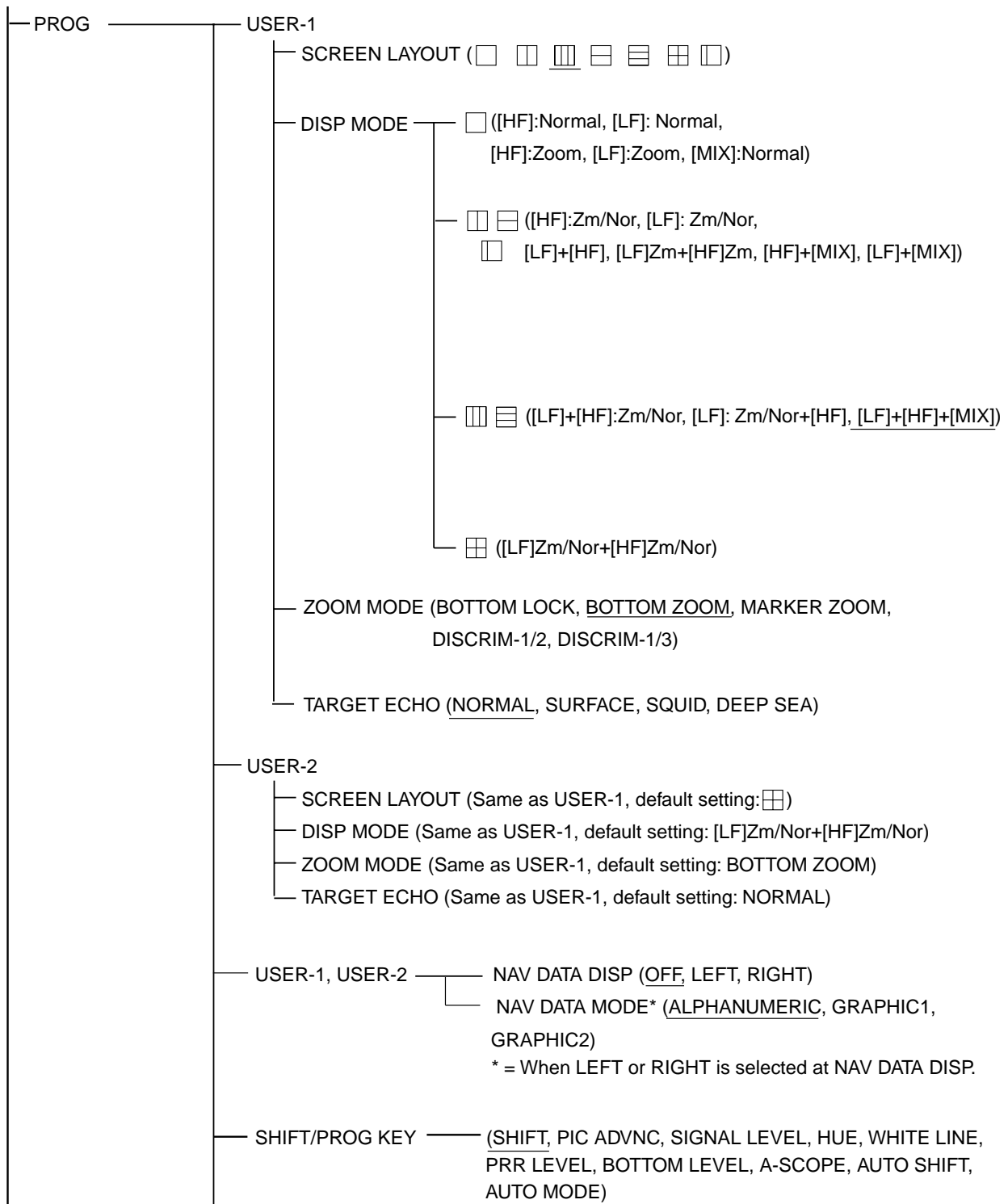

(Continued on next page)

(Continued from previous page)

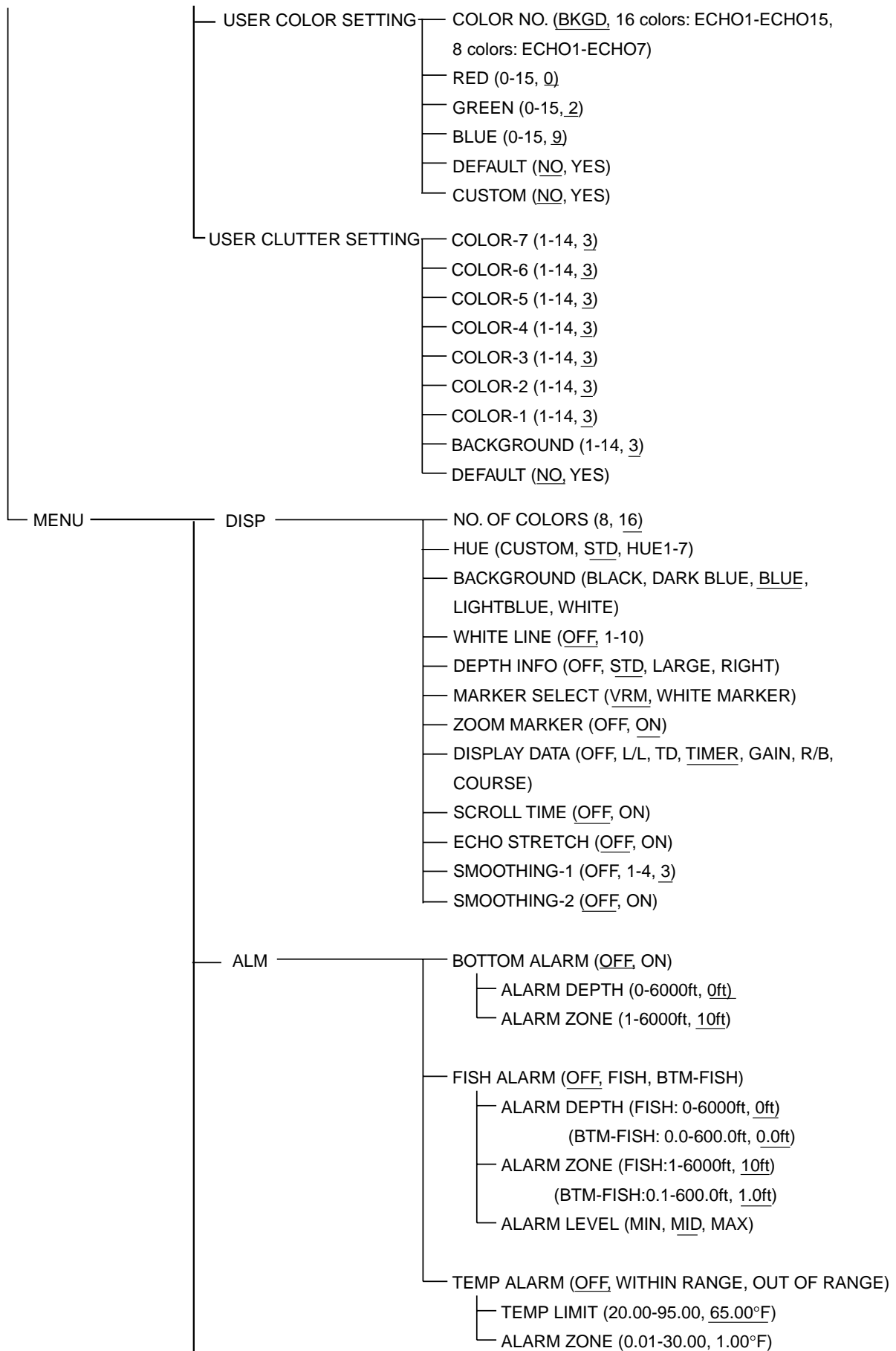

(Continued on next page)

(Continued from the previous page)

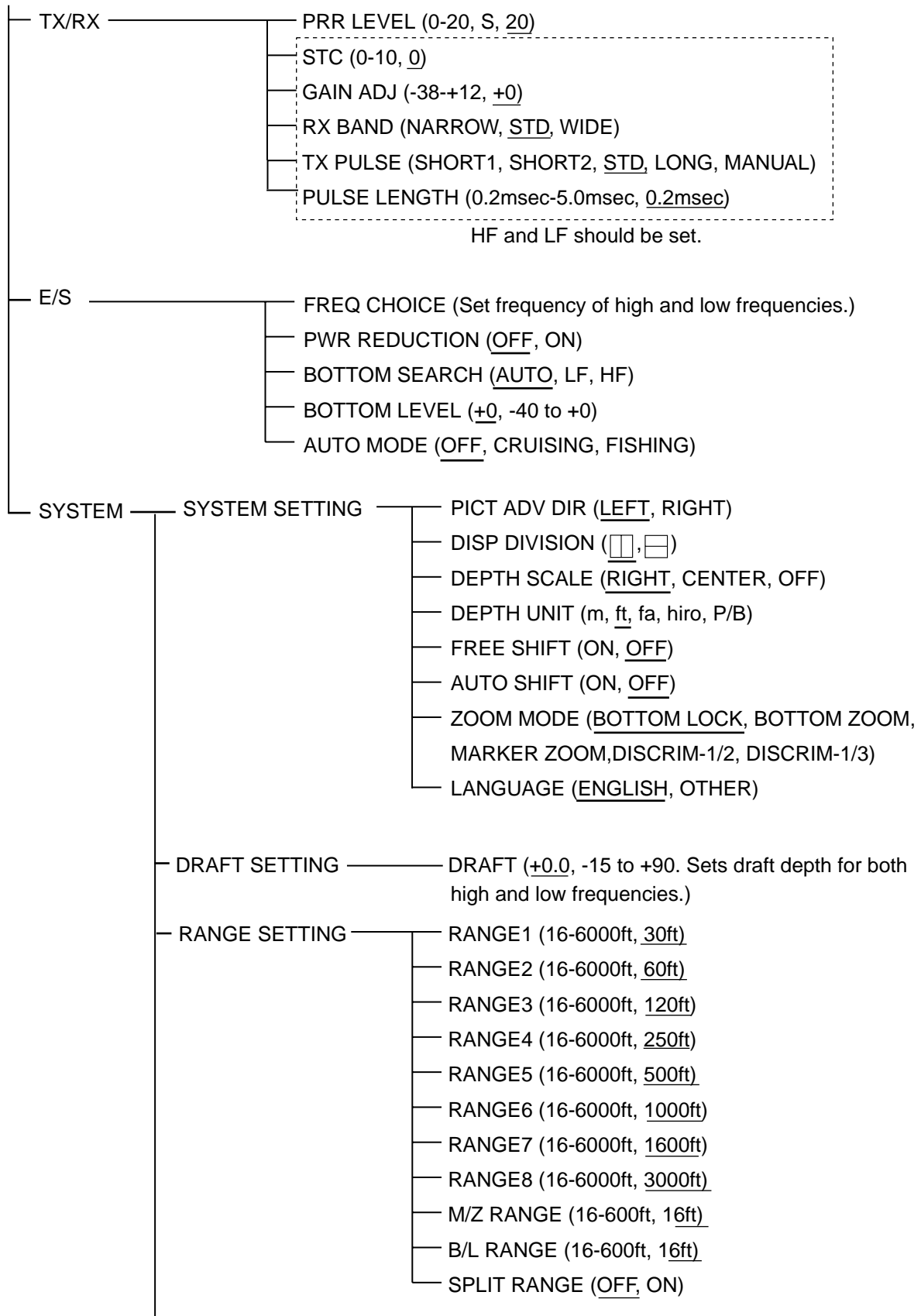

(Continued on the next page)

(Continued from previous page)

— TEMP SETTING	<ul style="list-style-type: none"> — TEMP UNIT (<u>°C</u>, <u>°F</u>) — TEMP INPUT (<u>SENSOR</u>, NMEA) — TEMP ADJUST (<u>+0.00°F</u>, -20 - +20) — TEMP OUTPUT (<u>ON</u>, OFF) — TEMP READOUT (OFF, <u>ON</u>) — TEMP GRAPH (<u>OFF</u>, NARROW, STD, EXPAND) — TEMP COLOR (<u>STD</u>, WHITE, RED, BLACK, YELLOW)
— NAV DATA SETTING	<ul style="list-style-type: none"> — SPEED UNIT (<u>kt</u>, km/h, MPH) — SPEED INPUT (SENSOR, <u>NMEA</u>) — SPEED ADJUST (<u>+0%</u>, -50 - +50%) — SPEED OUTPUT (OFF, <u>ON</u>) — SPEED INFO (<u>OFF</u>, ON) — NMEA VERSION (Ver 1.5, <u>Ver 2.0</u>, Ver 3.0, SPECIAL) — NAV DATA (LC, LA, DECCA, GPS, DR, <u>AUTO</u>) — COURSE (<u>TRUE</u>, MAG) — TLL OUTPUT (<u>OFF</u>, ON)
— TARGET ECHO	— TARGET ECHO (<u>NORMAL</u> , SURFACE, SQUID, DEEP SEA)
— TEST MODE	<ul style="list-style-type: none"> — DIAGNOSTICS (<u>NO</u>, YES) — TEST PATTERN (<u>NO</u>, YES)
— DEFAULT SETTING	— DEFAULT SET (<u>NO</u> , YES)

Screen Division

The screen may be divided as below with SCREEN LAYOUT on the USER-1/2 sub menu of the USER menu.

Full screen

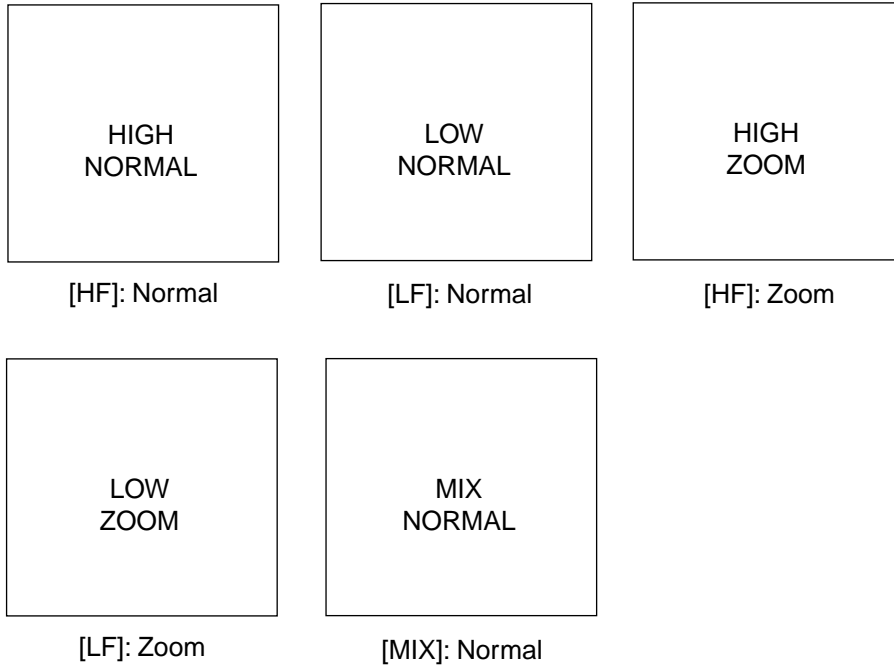

Halves screen

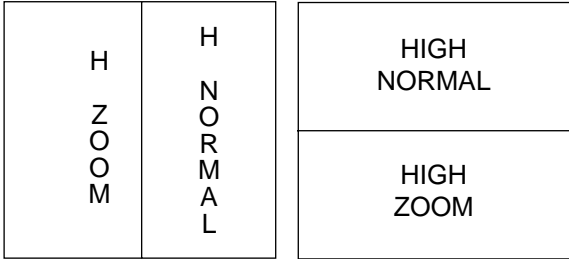

[HF]: Zm/Nor

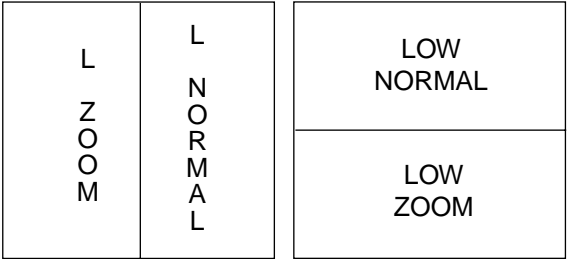

[LF]: Zm/Nor

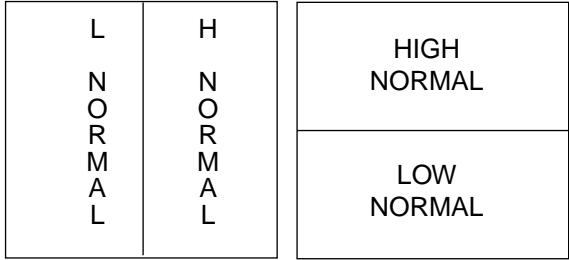

[LF]+[HF]

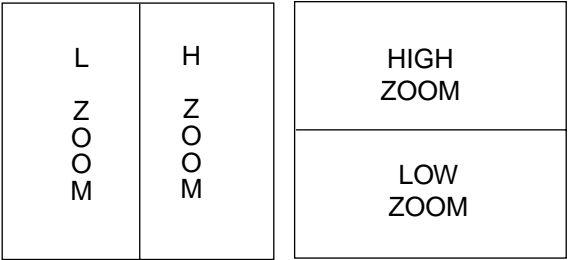

[LF]:Zm+[HF]:Zm

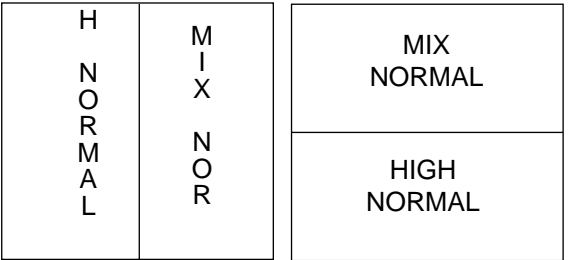

[HF]+[MIX]

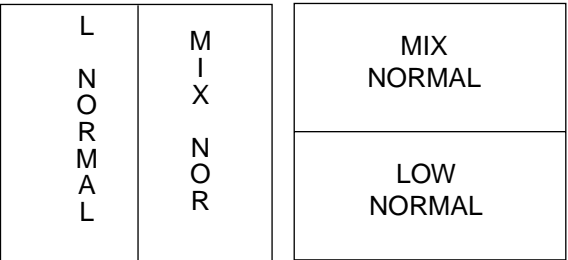

[LF]+[MIX]

Thirds screen

L N O R M A L	H Z O O M	H N O R M A L	HIGH NORMAL
			HIGH ZOOM
			LOW NORMAL

[LF]+[HF]: Zm/Nor

L Z O O M	L N O R M A L	H N O R M A L	HIGH NORMAL
			LOW NORMAL
			LOW ZOOM

[LF]: Zm/Nor+[HF]

L N O R M A L	H N O R M A L	M I X N O R	MIX NORMAL
			HIGH NORMAL
			LOW NORMAL

[LF]+[HF]+[MIX]

Fourths screen

LOW NOR	HIGH NOR
LOW ZOOM	HIGH ZOOM

[LF]: Zm/Nor+[HF]: Zm/Nor

Display Division

The display may be divided vertically and horizontally as shown below with DISP DIVISION on the SYSTEM SETTING menu.

Vertical division

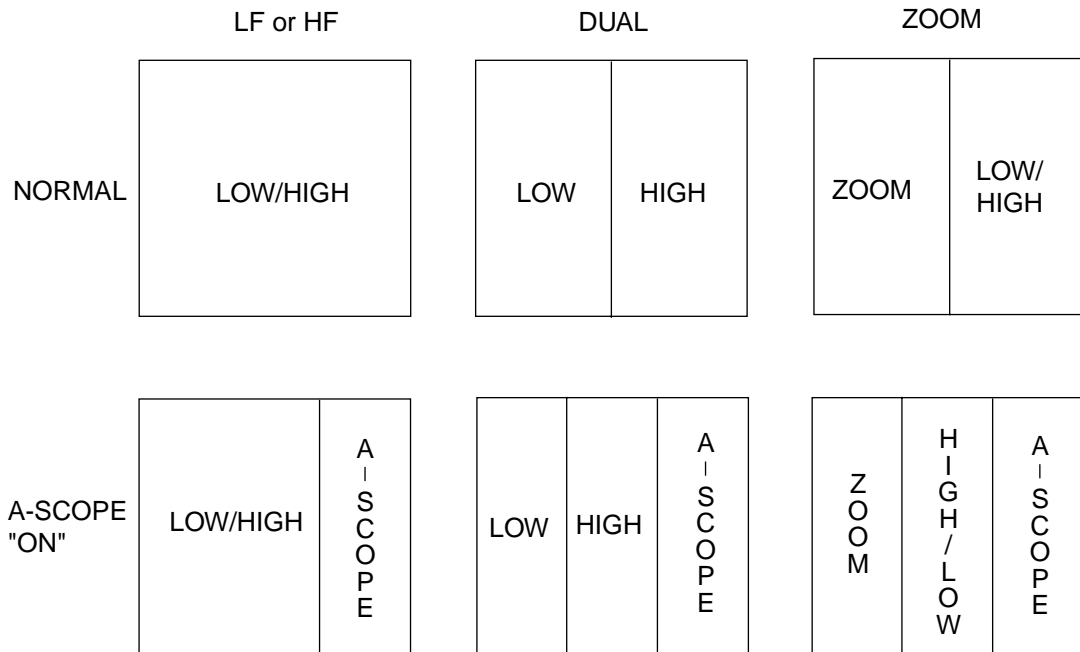

Horizontal division

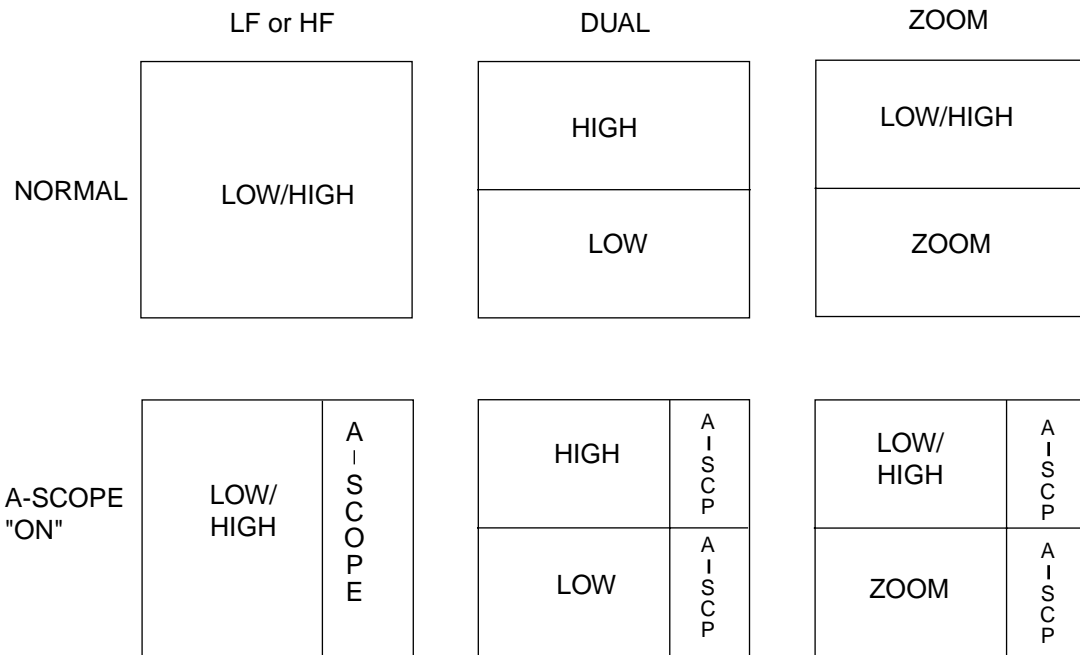

SPECIFICATIONS OF THE COLOR LCD VIDEO SOUNDER FCV-1100L

1. ECHO SOUNDER

- 1.1. TX Frequency 28/45/50/67/68/88/107/150/200 kHz, select 2 channels
- 1.2. Output Power 1, 2 or 3 kWrms
- 1.3. TX Rate Max. 2000 pulse/min (5 to 2000 m range, normal mode)
- 1.4. Pulselength 0.2 to 5.0 msec

2. DISPLAY UNIT

- 2.1. Display Mode 10.4 inch TFT color LCD, VGA: 640 x 480 pixels
- 2.2. Echo Color 8 or 16 colors according to echo intensity.
- 2.3. Background Color Selectable among 5 colors.
- 2.4. Display Mode Single mode (high/low frequency), Dual-frequency, Zoom, Mix, A-scope
- 2.5. Zoom Display Marker zoom, Bottom zoom, Bottom-lock expansion
- 2.6. Range Shift Range: 5-2000 m, Shift: 0-2000 m, Expansion range: 5-200 m
- 2.7. Display Advance Speed 7 steps (Lines/TX: Freeze, 1/16, 1/8, 1/4, 1/2, 1/1, 2/1, 3/1, 4/1)
- 2.8. Alarm Fish alarm, Water temperature alarm, Bottom alarm
- 2.9. Noise Limiter Frequency adjustable range: $\pm 10\%$ or
-10.0 to +6% for 28 kHz, -4.0 to +10% for 67/68 kHz,
-10.0 to +4% for 107 kHz, -9.0 to +10% for 200 kHz
- 2.10. Automatic Indication Full-auto, Automatic bottom tracking,
Water temperature graph (optional sensor required)

3. INTERFACE

- 3.1. Data Format IEC 61162-1, NMEA0183 Ver.1.5/2.0/3.0
- 3.2. Input Data GGA, GLC, GLL, GTD, MTW, RMA, RMB, RMC, BWC, VTG, VHW, XTE. Any talker is available
- 3.3. Output Data SDDBS, SDDBT, SDDPT, SDTLL, YCMTW*, VVHWH
*: Optional sensor required

4. POWER SUPPLY

- 4.1. Voltage and Current 12-24 VDC: 3.3-1.7 A
- 4.2. Power Consumption 40 VA or less
- 4.3. Rectifier (option) 100/110/220/230 VAC available

5. ENVIRONMENTAL CONDITION

- 5.1. Temperature -15 °C to +55 °C
- 5.2. Relative Humidity Less than 95% (at 40°C)
- 5.3. Water Resistance Display Unit (Panel): IEC IPX5

6. COATING COLOR

- 6.1. Display Unit Panel: N3.0 Sleektone No.535, Chassis: 2.5GY5/1.5

INDEX

A

- Aerated water..... 4-5
- ALM menu..... 2-6
- A-scope display 1-20
- Automatic mode2-11

B

- Background color..... 2-3
- Bottom alarm..... 2-6
- Bottom echo..... 4-2
- Bottom level2-11
- Bottom search.....2-11
- Bottom-lock display
 - example 1-6
 - range..... 3-5
- Bottom-zoom display 1-7
- BRILL key..... 1-3
- BTM-FISH alarm..... 2-6

C

- Clutter
 - adjusting..... 1-15
 - customizing 2-17
- Color bar 4-1
- Colors
 - customizing 2-16
 - selection..... 2-3
- Controls..... 1-1
- Current rip 4-4

D

- Default settings 5-6
- Depth indication 2-3
- Depth scale 3-2
- Depth unit..... 3-2
- Diagnostic test 5-3
- Discrimination display 1-8
- DISP menu..... 2-3
- Display data 2-4
- Display division 3-2, A-9
- DRAFT SETTING menu 3-4
- Dual frequency display 1-5

E

- E/S menu 2-10
- Echo stretch..... 2-5

F

- False image..... 4-5
- Fish alarm..... 2-6
- Fish school echoes..... 4-3
- Free shift..... 3-2
- Fuse replacement..... 5-2

G

- GAIN control 1-13
- Gain offset 2-9

H

- Heading reference 3-9
- Hue 2-3

I

- Indications 1-2

L

- Language..... 3-3

M

- Maintenance 5-1
- Marker line..... 1-14
- MARKER/TLL key 1-14
- Marker-zoom display
 - example 1-7
 - range 3-5
- Menu tree A-1
- Mix display..... 1-10
- MODE switch..... 1-4

N

- NAV DATA SETTING menu..... 3-8
- Navigation data source..... 3-9
- Noise limiter..... 1-21

P

- Panel test..... 5-4
- Picture advance
 - direction 3-2
 - speed 1-18
 - speed dependent..... 2-8
- Plankton..... 4-4
- Power reduction 2-11
- Pulse repetition rate 2-8

INDEX

Pulselength 2-9
PWR key 1-2

R

RANGE SETTING menu 3-5
RANGE switch 1-11
RX band 2-9

S

Screen division 2-13, A-6
Scroll time 2-5
Shift
 automatic 3-3
 manual 1-12
SHIFT/PROG key
 operating 1-22
 programming 2-15
Signal level 1-17
Smoothing 2-5
Speed data setup 3-8, 3-9
STC 2-9
Surface noise 4-5
System configuration v
SYSTEM menu 3-1
SYSTEM SETTING menu 3-2

T

TARGET ECHO menu 3-10
Temp alarm 2-6
Temperature data setup 3-7, 3-8
Test pattern 5-5
TLL output 3-9
Troubleshooting 5-2
TVG 1-16
Tx pulse 2-9
TX/RX menu 2-8

U

USER CLUTTER SETTING menu 2-17
USER COLOR SETTING menu 2-16
User display 1-9
USER menu 2-12

V

VRM 1-13

W

White line 2-3
White marker 2-4

Z

Zero line 4-2
Zoom
 displays 1-6
 mode preset 3-3
Zoom marker 2-4

Free Manuals Download Website

<http://myh66.com>

<http://usermanuals.us>

<http://www.somanuals.com>

<http://www.4manuals.cc>

<http://www.manual-lib.com>

<http://www.404manual.com>

<http://www.luxmanual.com>

<http://aubethermostatmanual.com>

Golf course search by state

<http://golfingnear.com>

Email search by domain

<http://emailbydomain.com>

Auto manuals search

<http://auto.somanuals.com>

TV manuals search

<http://tv.somanuals.com>