

FURUNO

INSTALLATION MANUAL

COLOR LCD SOUNDER

MODEL FCV-1100L



FURUNO ELECTRIC CO., LTD.
NISHINOMIYA, JAPAN

PRINTED IN JAPAN

© **FURUNO ELECTRIC CO., LTD.**

9-52 Ashihara-cho,
Nishinomiya, Japan

Telephone : 0798-65-2111
fax : 0798-65-4200

Your Local Agent/Dealer

All rights reserved.

Printed in Japan

PUB.No. IME-23670-C2

(TENI) FCV-1100L

FIRST EDITION : AUG. 2001

C2 : DEC. 10,2003



* 0008092200 *



* IME23670C20 *



SAFETY INSTRUCTIONS



WARNING



ELECTRICAL SHOCK HAZARD
Do not open the equipment unless totally familiar with electrical circuits and service manual.

Only qualified personnel should work inside the equipment.

Turn off the power at the switchboard before beginning the installation.

Fire or electrical shock can result if the power is left on.

Do not install the equipment where it may get wet from rain or water splash.

Water in the equipment can result in fire, electrical shock or equipment damage.

Be sure no water leaks in at the transducer mounting location.

Water leakage can sink the vessel. Also, confirm that the transducer will not loosen by ship's vibration. The installer of the equipment is solely responsible for the proper installation of the equipment. FURUNO will assume no responsibility for any damage associated with improper installation.

Be sure that the power supply is compatible with the voltage rating of the equipment.

Connection of an incorrect power supply can cause fire or equipment damage. The voltage rating of the equipment appears on the label above the power connector.



WARNING

Install the transducer according to the installation instructions.

Failure to install the transducer correctly may result in water leakage and damage to the ship's hull.

For wooden or FRP vessel using a steel tank, attach a zinc plate to the hull to prevent electrolytic corrosion.

Electrolytic corrosion can, in the worst case, result in loss of the transducer.



CAUTION



Ground the equipment to prevent mutual interference.

Observe the following compass safe distances to prevent interference to a magnetic compass:

	Standard compass	Steering compass
CV-1100L	0.7 m	0.5 m

Do not allow warm water or any other liquid other than seawater or freshwater to contact the transducer.

Damage to the transducer may result.

Do not install the transducer where noise or air bubbles is present.

Performance will be affected.



CAUTION

The transducer cable must be handled carefully, following the guidelines below.

- Keep fuels and oils away from the cable.
- Locate the cable where it will not be damaged.
- The cable sheath is made of chlorophrene or polychloride vinyl, which are easily damaged by plastic solvents such as toluene. Locate the cable well away from plastic solvents.

TABLE OF CONTENTS

SYSTEM CONFIGURATION	iv
EQUIPMENT LISTS	v
1. MOUNTING	1-1
1.1 Display Unit	1-1
1.2 Transducer.....	1-4
1.3 Water Temperature Sensor (option)	1-4
2. WIRING	2-1
2.1 Wiring Standard Equipment	2-2
2.2 Wiring Optional Equipment	2-3
2.3 Input/Output Sentences	2-3
3. INITIAL SETTING	3-1
3.1 Language Setting.....	3-1
3.2 Transducer Data	3-2
3.3 Water Temperature Sensor Setting	3-7
3.4 Nav Data, Heading Sensor Setting	3-9
3.5 Propagation Velocity	3-11
3.6 Demonstration Mode.....	3-12
3.7 Restoring Default Settings	3-13
APPENDIX 1 TRANSDUCER 50BL-12/50BL-24H	AP-1
APPENDIX 2 NEW BLT TRANSDUCERS	AP-2
PACKING LISTS	A-1
OUTLINE DRAWINGS	D-1
SCHEMATIC DIAGRAM	S-1

SYSTEM CONFIGURATION

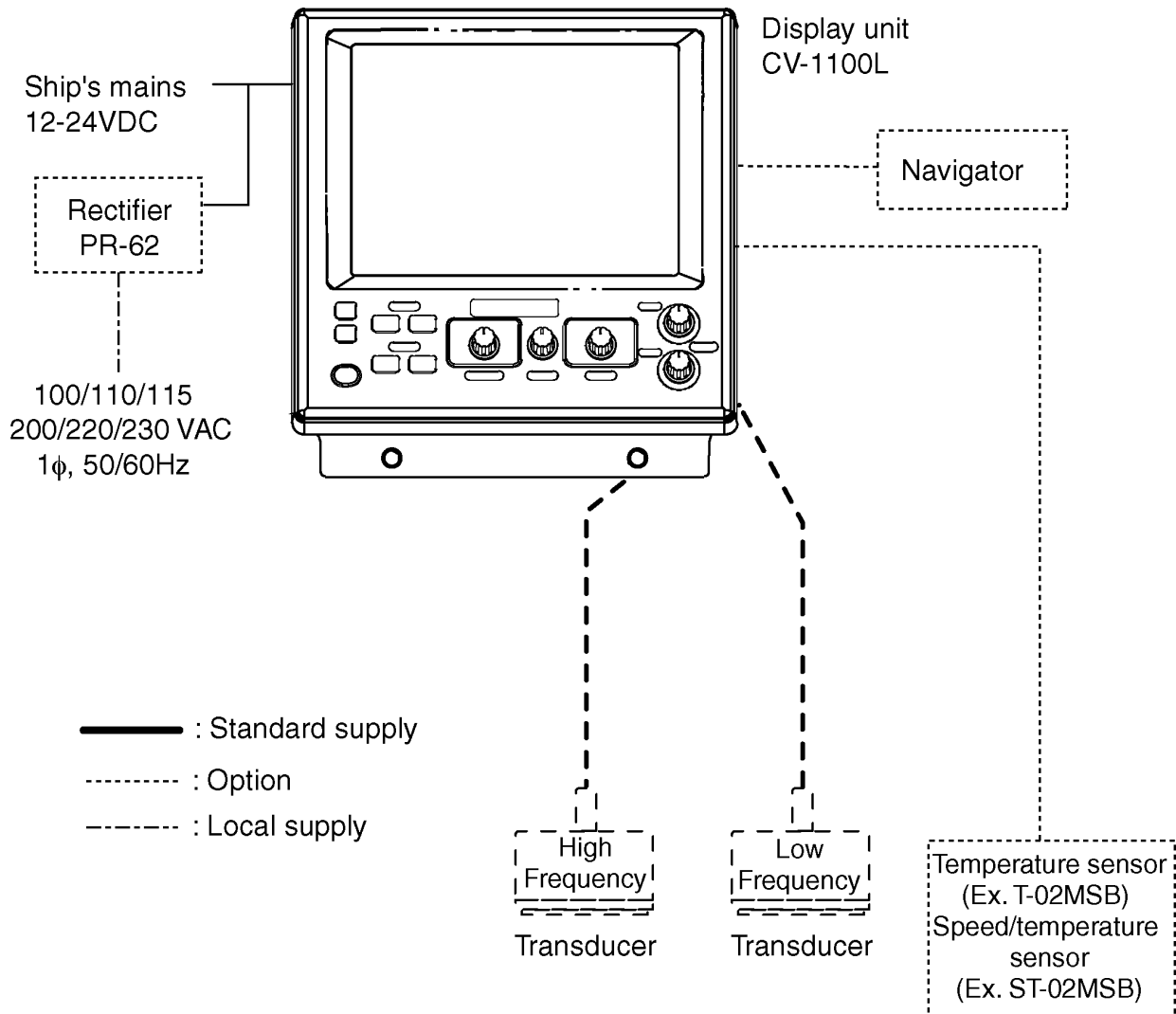

EQUIPMENT LISTS

Standard supply

Name	Type	Code No.	Qty	Remarks
Display unit	CV-1100L	-	1	
Spare Parts	SP02-04401	001-402-100	1 set	Fuse
Accessories	FP02-05300	000-012-509	1 set	Hood
Installation Materials	CP02-06900	000-012-508	1 set	MJ-A3SPF0013-035 (3.5 m), CP02-06901

Options

Name	Type	Code No.	Qty	Remarks
Transducer	Transducer available in 1, 2 and 3 kW models. See page vi – xiii for details. No selection also available.			
Cable Assy	MJ-A6SPF0012-050	000-134-424	1	6P-6P, 5m, for navigator
	MJ-A6SPF0012-100	000-133-817	1	6P-6P, 10m, for navigator
	MJ-A6SPF0011-050	000-132-244	1	6P-4P, 5m, for navigator
	MJ-A6SPF0011-100	000-132-336	1	6P-4P, 10m, for navigator
	NCS255AD-254P-L500	000-142-518	1	For dual –frequency transducer
Water Temperature Sensor	T-02MSB	000-040-040	1	Thru-hull mount
	T-02MTB	000-040-026	1	Transom mount
	T-03MSB	000-040-027	1	Thru-hull mount
Speed/Temperature Sensor	ST-02MSB	000-137-986	1	
	ST-02PSB	000-137-987	1	
Rectifier	PR-62	000-013-484	1	100 VAC
		000-013-485		110 VAC*
		000-013-486		220 VAC
		000-013-487		230 VAC

*: Use this type for 115 VAC.

Available transducers

1 kW transducer

Frequency (kHz)	Hull Material	Transducer	Thru-Hull Pipe	Tank
28/50	Steel	28F-8 50B-6/6B	-	-
	FRP		-	-
	Steel	28F-8 50B-9/9B	TWB-6000 (2)	T-656
	FRP		-	-
	Steel	28F-8 50F-8G	-	-
	FRP		-	-
28/68	Steel	28F-8 68F-8H	-	-
	FRP		-	-
28/88	Steel	28F-8 88B-8	TWB-6000 (2)	T-657
	FRP		-	-
28/200	Steel	28F-8 200B-5S	-	-
	FRP		-	-
50/88	Steel	50B-6/6B 88B-8	-	-
	FRP		-	-
	Steel	50B-9/9B 88B-8	TWB-6000 (2)	T-658
	FRP		-	-
	Steel	50F-8G 88B-8	-	-
	FRP		-	-
50/200	Steel	50B-6/6B 200B-5S	-	-
	FRP		-	-
	Steel	50B-9/9B 200B-5S	-	-
	FRP		-	-
	Steel	50F-8G 200B-5S	-	-
	FRP		-	-
	Steel	50/200-1T	-	-
	FRP		-	-
	Steel	50/200-1ST	-	-
	FRP		-	-
68/200	Steel	68F-8H 200B-5S	-	-
	FRP		-	-
88/200	Steel	88B-8 200B-5S	-	-
	FRP		-	-

2 kW transducer

Frequency (kHz)	Hull Material	Transducer	Thru-Hull Pipe	Tank
28/50	Steel	28F-18	TFB-7000 (2)	T-634
	FRP	50B-12	-	-
28/68	Steel	28F-18	-	-
	FRP	68F-30H	TRB-1100 (2)	T-634-F
28/88	Steel	28F- 18	TFB-7000 (2)	T-636
	FRP	88B-10	TFB-1100 (2)	T-636-F
28/200	Steel	28F-18	TFB-7000 (2)	T-638
	FRP	200B-8/8B/8N	TFB-1100 (2)	T-638-F
50/88	Steel	50B-12	TFB-7000 (2)	T-643
	FRP	200B-8/8B/8N	TFB-1100 (2)	T-643-F
50/200	Steel	50B-12	TFB-7000 (2)	T-645
	FRP	200B-8/8B/8N	-	-
68/200	Steel	68F-30H	TFB-7000 (2)	-
	FRP	200B-8/8B/8N	TFB-1100 (2)	-
88/200	Steel	88B-10	TFB-7000 (2)	T-649
	FRP	200B-8/8B/8N	TFB-1100 (2)	T-649-F

3 kW transducer

Frequency (kHz)	Hull Material	Transducer	Thru-Hull Pipe	Tank
28/50	Steel	28F-24H, 50F-24H	TFB-7000 (2)	T-681
	FRP		TRB-1100 (2)	T-681-F
28/68	Steel	28F-24H, 68F-30H	-	-
	FRP		-	-
28/88	Steel	28F-24H, 88F-126H	TFB-7000 (2)	T-682
	FRP		TRB-1100 (2)	T-682-F
28/107	Steel	28F-24H, 100B-10R	-	-
	FRP		-	-
28/150	Steel	50B-6/6B, 88B-8	-	-
	FRP		-	-
28/200	Steel	28F-24H, 200B-12H	-	-
	FRP		-	-
50/88	Steel	50F-24H, 88F-126H	TFB-7000 (2)	T-682
	FRP		TRB-1100 (2)	T-682-F
50/107	Steel	50F-24H, 100B-10R	-	-
	FRP		-	-
50/150	Steel	50F-24H, 150B-12H	TFB-7000 (2)	T-683
	FRP		TRB-1100 (2)	T-683-F
50/200	Steel	50F-24H, 200B-12H	TFB-7000 (2)	T-683
	FRP		TFB-1100 (2)	T-638-F
68/107	Steel	68F-30H, 100B-10R	-	-
	FRP		-	-
68/150	Steel	68F-30H, 150B-12H	TFB-7000 (2)	T-646
	FRP		TFB-1100 (2)	T-646-F
68/200	Steel	68F-30H, 200B-12H	TFB-7000 (2)	T-646
	FRP		TFB-1100 (2)	T-646F
88/150	Steel	88F-126H, 150B-12H	-	-
	FRP		-	-
88/200	Steel	88F-126H, 200B-12H	TFB-7000 (2)	T-685
	FRP		TFB-1100 (2)	T-685-F
107/200	Steel	100B-10R, 200B-12H	TFB-7000 (2)	-
	FRP		TFB-1100 (2)	-

1 kW/2 kW transducer

Output (W)	Frequency (kHz)	Hull Material	Transducer	Thru-Hull Pipe	Tank
1 k/2 k	28/50	Steel	28F-8	-	-
		FRP	50B-12	-	-
	28/68	Steel	28F-8	-	-
		FRP	68F-30H	-	-
	28/88	Steel	28F-8	-	-
		FRP	88B-10	-	-
	28/200	Steel	28F-8	TWB-6000 (2)	T-657
		FRP	200B-8/8B/8N	-	-
	50/88	Steel	50B-6/6B	-	-
			88B-10	-	-
		FRP	50B-9/9B	-	-
			88B-10	-	-
		Steel	50F-8G	TFB-7000 (2)	T-636
			88B-10	TRB-1100 (2)	T-636-F
	50/200	Steel	50B-6/6B	-	-
			200B-8/8B/8N	-	-
		FRP	50B-9	TWB-6000 (2)	T-658
			200B-8/8B/8N	-	-
		Steel	50F-8G	TFB-7000 (2)	T-638
			200B-8/8B/8N	TFB-1100 (2)	T-638-F
	68/200	Steel	68F-8H	-	-
		FRP	200B-8/8B/8N	-	-
	88/200	Steel	88B-8	TWB-6000 (2)	T-659
		FRP	200B-8/8B/8N	-	-

EQUIPMENT LISTS

1 kW/3 kW transducer

Output (W)	Frequency (kHz)	Hull Material	Transducer	Thru-Hull Pipe	Tank	
1 k/3 k	28/45	Steel	28F-8	-	-	
		FRP	45F-12H	-	-	
	28/50	Steel	28F-8	-	-	
		FRP	50F-24H	-	-	
	28/68	Steel	28F-8	-	-	
		FRP	68F-30H	-	-	
	28/88	Steel	28F-24H,	-	-	
		FRP	100B-10R	-	-	
	28/150	Steel	28F-8	-	-	
		FRP	88F-126H	-	-	
	28/107	Steel	28F-8	-	-	
		FRP	100B-10R	-	-	
	28/150	Steel	28F-8	-	-	
		FRP	150B-12H	-	-	
	28/200	Steel	28F-8	-	-	
		FRP	200B-12H	-	-	
	50/88	50/88	Steel	50B-6/6B	-	-
			FRP	88F-126H	-	-
		50/88	Steel	50B-9B	-	-
			FRP	88F-126H	-	-
		50/88	Steel	50F-8G	-	-
			FRP	88F-126H	-	-
	50/107	50/107	Steel	50B-6/6B	-	-
			FRP	100B-10R	-	-
		50/107	Steel	50B-9/9B	-	-
			FRP	100B-10R	-	-
		50/107	Steel	50F-8	-	-
			FRP	100B-10R	-	-
	50/150	50/150	Steel	50B-6/6B	-	-
			FRP	150B-12H	-	-
50/150		Steel	50B-9/9B	-	-	
		FRP	150B-12H	-	-	
50/150		Steel	50F-8G	-	-	
		FRP	150B-12H	-	-	

Output (W)	Frequency (kHz)	Hull Material	Transducer	Thru-Hull Pipe	Tank
1 k/3 k	50/200	Steel	50B-6/6B	-	-
		FRP	200B-12H	-	-
		Steel	50B-9/9B	-	-
		FRP	200B-12H	-	-
		Steel	50F-8G	-	-
		FRP	200B-12H	-	-
	68/107	Steel	68F-8H	-	-
		FRP	100B-10R	-	-
	68/150	Steel	68F-8H	-	-
		FRP	150B-12H	-	-
	68/200	Steel	68F-8H	-	-
		FRP	200B-12H	-	-
	88/150	Steel	88B-8	-	-
		FRP	150B-12H	-	-
	88/200	Steel	88B-8	-	-
		FRP	200B-12H	-	-

2 kW/3 kW transducer

Output (W)	Frequency (kHz)	Hull Material	Transducer	Thru-Hull Pipe	Tank
2 k/3 k	28/45	Steel	28F-18	-	-
		FRP	45F-12H	-	-
	28/50	Steel	28F-18	-	-
		FRP	50F-24H	-	-
	28/68	Steel	28F-18	-	-
		FRP	68F-30H	-	-
	28/88	Steel	28F-18	-	-
		FRP	88F-126H	-	-
	28/107	Steel	28F-18	TFB-7000 (2)	T-636
		FRP	100B-10R	TRB-1100 (2)	T-636-F
	28/150	Steel	28F-18	TFB-7000 (2)	T-637
		FRP	150B-12H	TRB-1100 (2)	T-637-F
	28/200	Steel	28F-18	-	-
		FRP	200B-12H	-	-
	50/88	Steel	50B-12	-	-
		FRP	88F-126H	-	-
	50/107	Steel	50B-12	TFB-7000 (2)	T-643
		FRP	100B-10R	TRB-1100 (2)	T-643-F
	50/150	Steel	50B-12	TFB-7000 (2)	T-644
		FRP	150B-12H	TRB-1100 (2)	T-644-F
	50/200	Steel	50B-12	-	-
		FRP	200B-12H	-	-
	68/107	Steel	68F-30H	-	-
		FRP	100B-10R	-	-
	68/150	Steel	68F-30H	-	-
		FRP	150B-12H	-	-
	68/200	Steel	68F-30H	-	-
		FRP	200B-12H	-	-
88/150	Steel	88B-10	-	-	
	FRP	150B-12H	-	-	
88/200	Steel	88B-10	-	-	
	FRP	200B-12H	-	-	

3 kW/2 kW transducer

Output (W)	Frequency (kHz)	Hull Material	Transducer	Thru-Hull Pipe	Tank
3 k/2 k	28/50	Steel	28F-24H	-	-
		FRP	50B-12	-	-
	28/68	Steel	28F-24H	-	-
		FRP	68F-30H	-	-
	28/88	Steel	28F-24H	-	-
		FRP	88B-10	-	-
	28/200	Steel	28F-24H	-	-
		FRP	200B-8/8B/8N	-	-
	50/88	Steel	50F-24H	-	-
		FRP	88B-10	-	-
	50/200	Steel	50F-24H	-	-
		FRP	200B-8/8B/8N	-	-
	68/200	Steel	68F-30H	TFB-7000 (2)	T-647
		FRP	200B-8/8B/8N	TRB-1100 (2)	T-645-F
	88/200	Steel	88F-126H	-	-
		FRP	200B-8/8B/8N	-	-
	107/200	Steel	100B-10R 200B-8/8B/8N	TFB-7000 (2)	T-649
		FRP		TRB-1100 (2)	T-649-F
FRP		-		-	

EQUIPMENT LISTS

This page is intentionally left blank.

1. MOUNTING

1.1 Display Unit



WARNING

Turn off the power at the switchboard before beginning the installation.

Fire or electrical shock can result if the power is left on.

Mounting considerations

- Locate the unit out of direct sunlight.
- The operator should face the bow while viewing the display screen.
- Select a location where the display screen can be easily observed while operating the control unit.
- Leave sufficient space around the unit for maintenance and servicing. Recommended maintenance space appears in the outline drawing at the back of this manual.

1. MOUNTING

Mounting procedure

Desktop mounting

1. Loosen two M6 x 25 bolts at the front of the display unit to remove the mounting base.

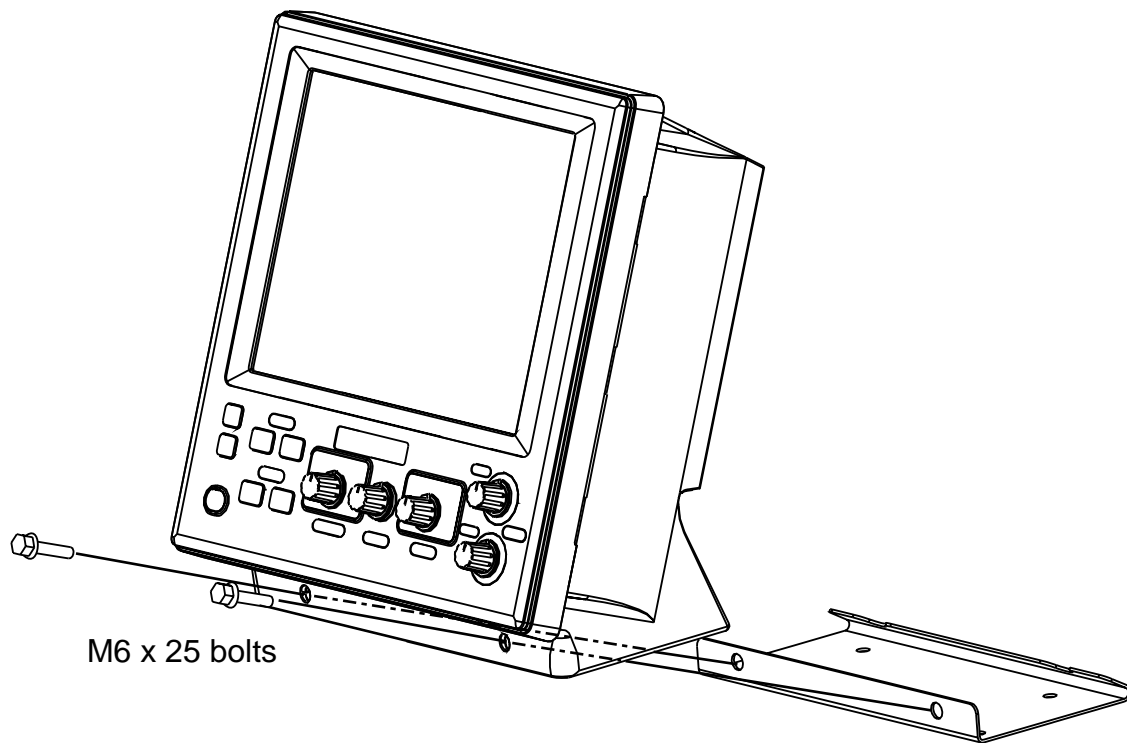

Removing the display unit from the mounting base

2. Use the four tapping screws (5 x 20, supplied as installation materials) to fasten the mounting base.
3. Apply grease to the bolts removed at step 1.
4. Lay the display unit on the mounting base. Fasten the display unit to the mounting base with the two M6 x 25 bolts greased at step 3.

Flush mounting

1. Make cutout in mounting location referring to the outline drawing show below.
2. Fasten the display unit to the mounting location with four pan head screws.

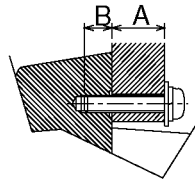
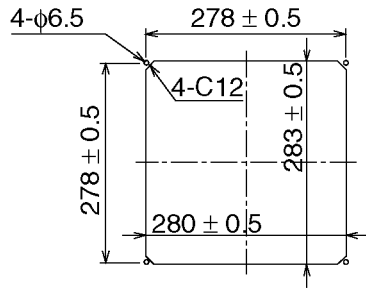

Fixing screw, side view

Use pan head screws (local supply) when the thickness of the bulkhead is from 11 to 14 mm. For bulkhead which exceeds 14 mm in thickness the length of the pan head screws should be bulkhead thickness (A) plus 7.3 + 1.5 mm. Also the length of B should be max. 7 mm.

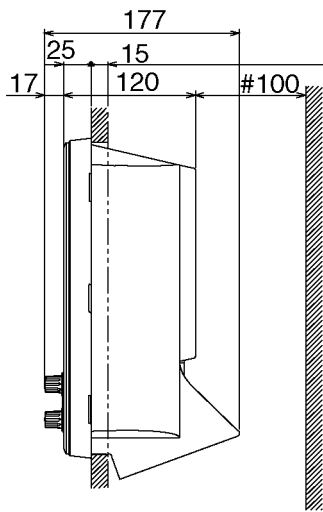

Side view

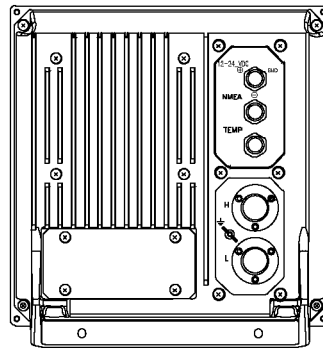

Rear view

Flush mounting display unit

1.2 Transducer

The performance of the video sounder depends upon the transducer position. A place least affected by air bubbles should be selected since turbulence blocks the sounding path. Further, select a place least influenced by engine noise. It is known that air bubbles are fewest at the place where the bow first falls and the next wave rises, at usual cruising speed.

Note: The face of the transducer must be facing the sea bottom in normal cruising trim of the boat.

1.3 Water Temperature Sensor (option)

Transom mount water temperature sensor T-02MTB

- Fix the cable at a convenient location on the transom with the cable clamp.
- When the cable is led through the transom board, make a hole of approx. 17 mm in diameter to pass the cable. After passing the cable, seal the hole with a sealing compound.

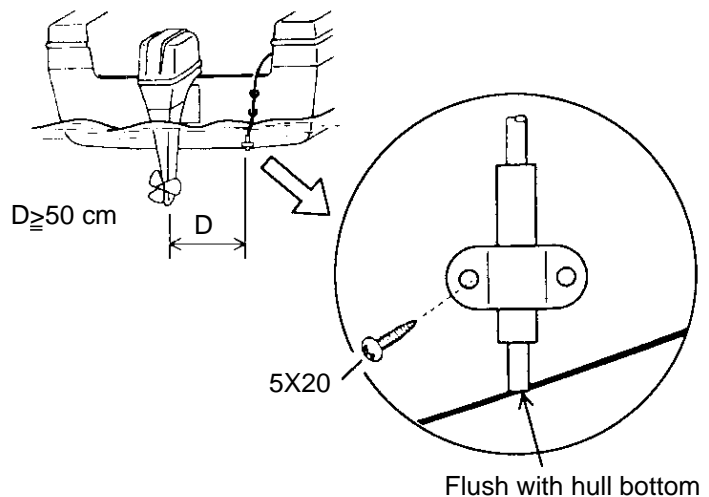

How to mount transom mount water temperature sensor T-02MTB

Thru-hull mount water temperature sensor T-02MSB, T-03MSB

- Select a suitable mounting location considering the following points:
- Select a mid-boat flat position. The sensor does not have to be installed perfectly perpendicular; however, the location should not be such that the transducer may be damaged when the boat is dry-docked.
- Locate away from equipment which gives off heat.
- Locate away from drain pipes.
- Select a location where vibration is minimal.

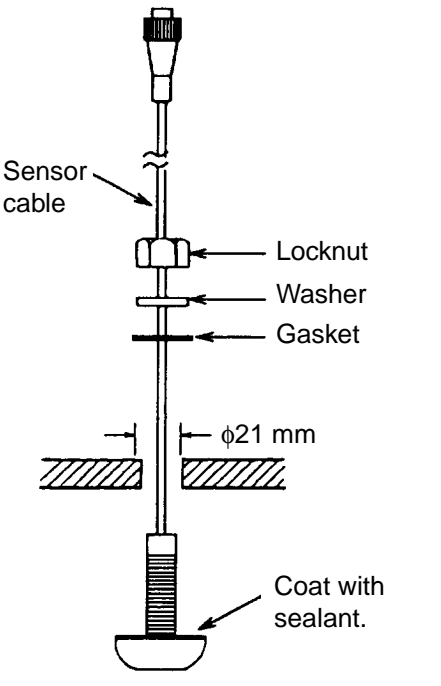
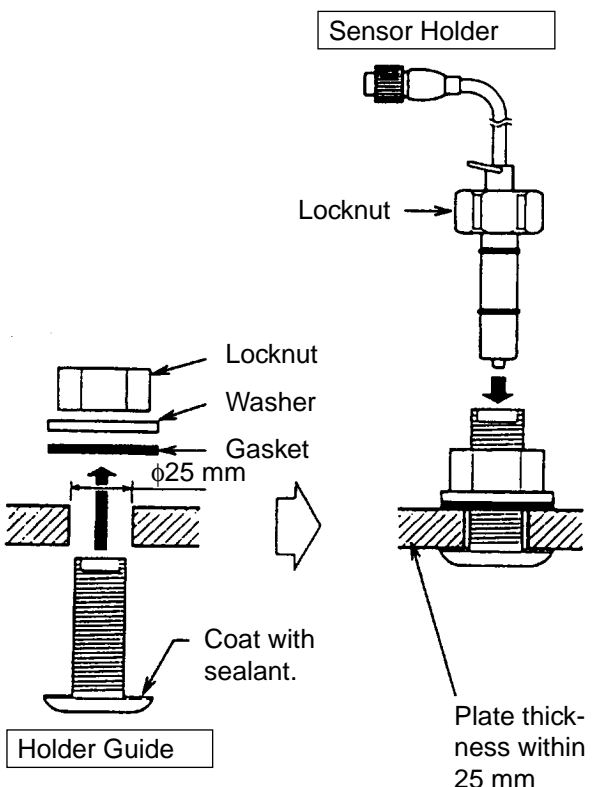
T-02MSB	T-03MSB
 <p>The diagram shows a vertical sensor cable passing through a hole in a plate. From top to bottom, the components are: a locknut, a washer, and a gasket. The hole in the plate has a diameter of 21 mm. The sensor flange at the bottom is coated with sealant. Labels include: Sensor cable, Locknut, Washer, Gasket, $\phi 21$ mm, and Coat with sealant.</p> <p>Mounting procedure</p> <ol style="list-style-type: none"> 1. Drill a hole of 21 mm in diameter in the mounting location. 2. Pass the sensor cable through the hole. 3. Pass gasket, washer and locknut onto cable in that order. 4. Coat the sensor flange with high quality sealant and then fasten the sensor with the locknut. (Torque: max. 59N·m) 5. Launch the boat to check for water leakage around the sensor. 	 <p>The diagram shows a sensor holder assembly. A holder guide is first inserted into a hole in a plate. The holder guide has a diameter of 25 mm. A locknut, washer, and gasket are placed on the holder guide. The holder guide is coated with sealant. Then, the sensor holder is inserted from the inside of the boat and secured with the locknut. Labels include: Sensor Holder, Locknut, Washer, Gasket, $\phi 25$ mm, Coat with sealant, Holder Guide, and Plate thickness within 25 mm.</p> <p>Mounting procedure</p> <ol style="list-style-type: none"> 1. Drill a hole of 25 mm in diameter in the mounting location. 2. Coat holder guide with high quality sealant, and pass gasket, washer and locknut onto holder guide in that order and then tighten the locknut. 3. Set the sensor holder to the holder guide from inside the boat and then tighten the locknut. 4. Launch the boat to check for water leakage around the sensor.

Assembling thru-hull water temperature sensor T-02MSB, T-03MSB

Through-hull mount water temperature/speed sensor ST-02MSB, ST02-PSB

Select a suitable mounting location considering the following:

- Select a mid-boat flat position. The sensor does not have to be installed perfectly perpendicular. The sensor must not be damaged in dry-docking operation.
- Select a place apart from equipment generating heat.
- Select a place in the forward direction viewing from the drain hole, to allow for circulation of cooling water.
- Select a place free from vibration.

1. Dry-dock the boat.
2. Make a hole of approx. 51 mm diameter.
3. Unfasten locknut and remove the sensor section.
4. Apply high-grade sealant to the flange of the sensor.
5. Pass the sensor casing through the hole.
6. Face the notch on the sensor toward boat's bow and tighten the flange.
7. Set the sensor section to the sensor casing and tighten the locknut.
8. Launch the boat and check for water leakage around the sensor.

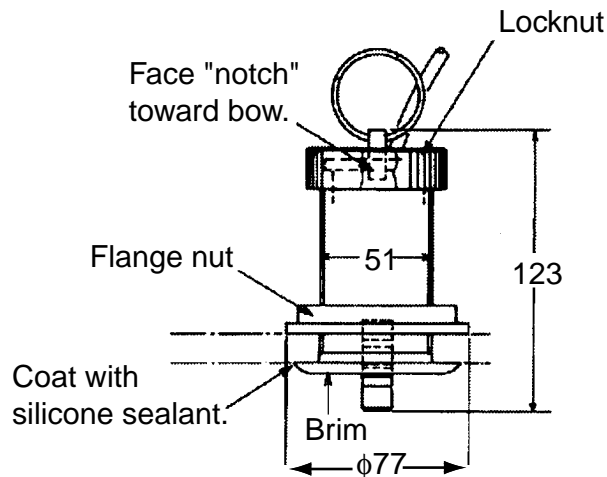

Water temperature/speed sensor ST-02MSB, ST-02PSB

2. WIRING

Refer to the interconnection diagram at the back of this manual for detailed information.

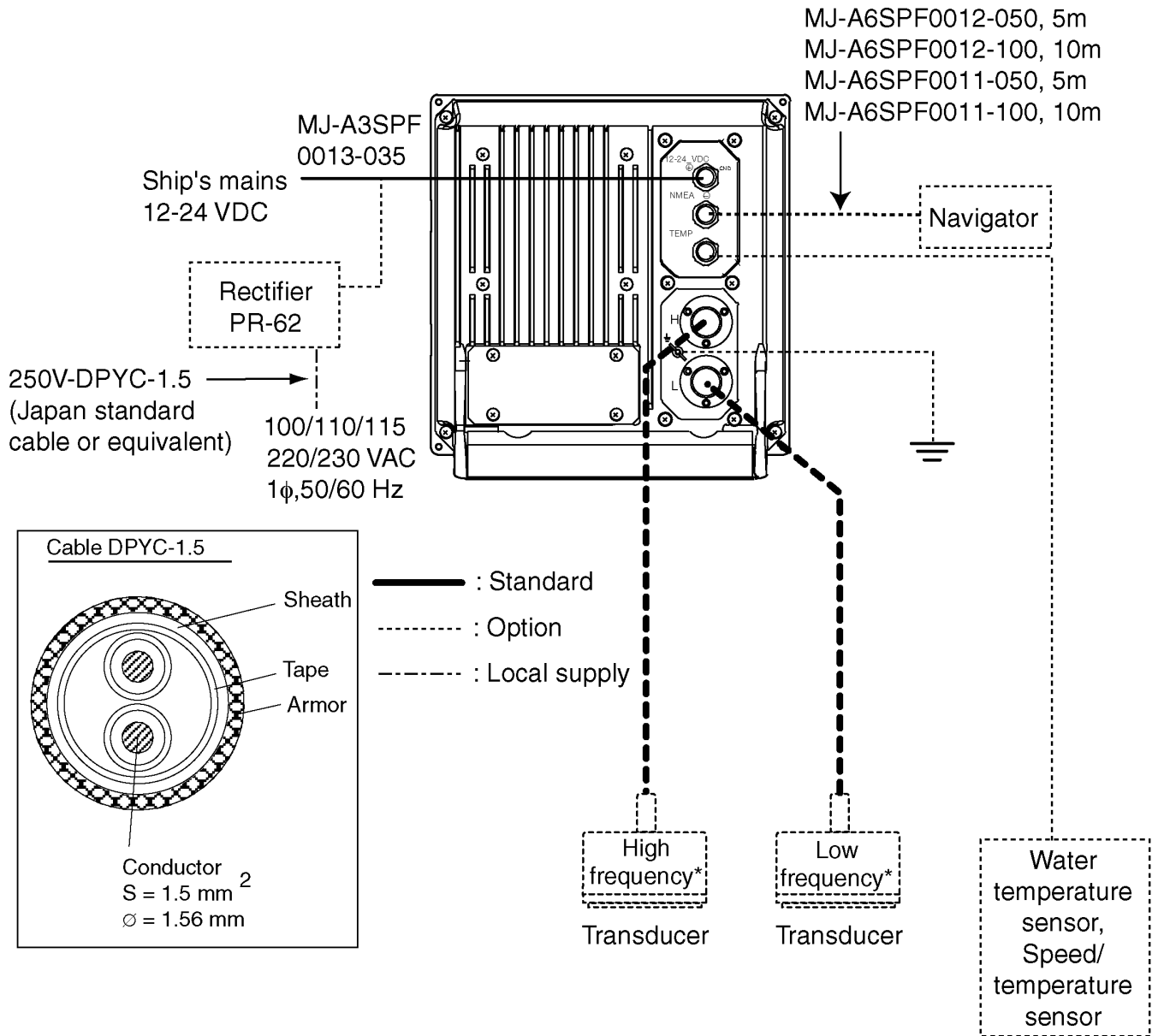

Wiring diagram for standard-type FCV-1100L

2.1 Wiring Standard Equipment

Transducer

Separate the transducer cable well away from power cables to prevent interference. Connect the cable to the transducer connector at the rear of the display unit. Fabricate the cable as below.

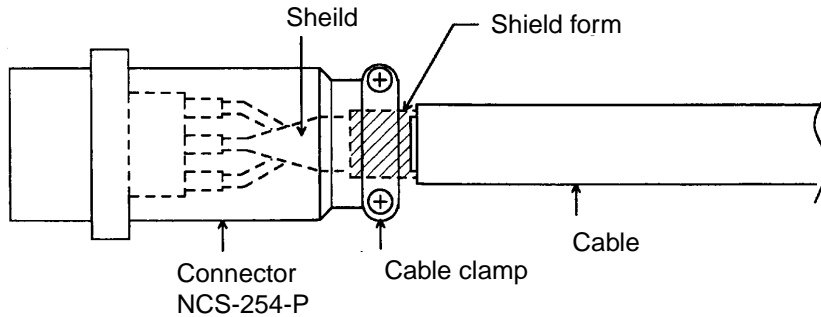

Fabrication of transducer cable

Note 1: For connection of dual-frequency transducer, use cable assy. NCS255AD-254P-L500 (option).

Note 2: Do not connect the transducer of 38 kHz or lower to the high frequency connector.

Note 3: FCV-1100L cannot accept the transducers of 54 – 64 kHz, 112 – 122 kHz and 171 – 181 kHz.

Power cable

This video sounder is designed to be powered with 12-24 VDC power. Use the cable assy MJ-A3SPF0013-035 (supplied as installation material).

Ground

The display unit should be grounded to prevent mutual interference. Connect an earth wire (2 sq, local supply) between unit and ship's superstructure to ground. The length of the earth wire should be as short as possible.

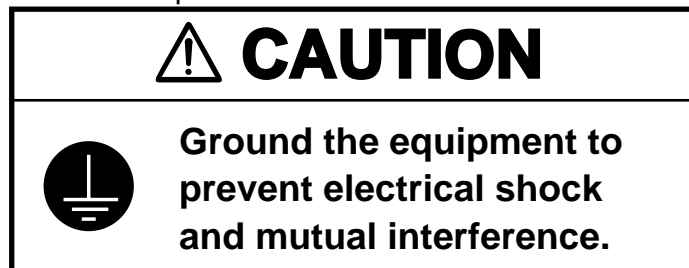

2.2 Wiring Optional Equipment

Navigator

Use cable type MJ-A6SPF0011/0012 (option) to connect the navigator to the NMEA connector.

Water temperature sensor T-02MSB, T-02MTB, T-03MSB

Connect the water temperature sensor cable to the TEMP connector.

2.3 Input/Output Sentences

Input sentences

Sentence	Data	Remarks
BWC	Range/bearing to waypoint	
GGA	Time, position	
GLC	GRI, TD (Loran C)	
GLL	Latitude and longitude	
GTD	TD (Loran C)	
MTW	Water temperature	
RMA	Latitude and longitude, TD, ground speed and course by a LORAN-C receiver	
RMB	Recommended minimum navigation information	
RMC	Latitude and longitude, speed over ground and course over by a GPS	
VHW	True/magnetic bearing, speed through water	Great circle
VTG	Speed through the ground and course	
XTE	Cross track error	

Output sentences

Sentences	Talker	Data	Remarks
DBS	SD	Depth below sea surface	Ver. 1.5
DBT	SD	Depth below transducer	Ver. 1.5
DPT	SD	Depth below transducer	Ver. 2.0
MTW	YC	Water temperature	Ver. 1.5 Ver. 2.0 with connection of water temperature sensor
TLL	SD	Marker line position	Ver. 2.0
VRM	SD	VRM depth	
VHW	VW	Ship's speed	

2. WIRING

This page is intentionally left blank.

3. INITIAL SETTING

This section provides the information necessary for initial setup of the equipment. First turn on the power and set display language. In addition, either transducer used, by model number (FURUNO transducer only) or by specifications.

3.1 Language Setting

1. Turn on the power. The following display appears.

Please set language.
([▲/▼]: Select, [+]: Enter)

XXXXXXXXX
XXXXXXXXX *(For Japanese customers)*

English
XXXXXX *(Japanese)*

Initial display screen

2. Press [▲] to select English, and then press the [+] key to set. The following display appears. For other languages, select appropriately.

Carry out transducer setting.
Press any key to go to Transducer setting menu.

3. Set transducer type. Then, go to applicable section (s) by pressing any key.

3.2 Transducer Data

⚠ CAUTION
<p>Set the transducer model number properly.</p> <p>Wrong transducer setting can damage the transducer and void the warranty.</p>

⚠ CAUTION
<p>Do not enter transducer data by specifications if model number of transducer used is programmed in the equipment.</p> <p>Wrong transducer setting can damage the transducer and void the warranty.</p>

The following models are programmed in the FCV-1100L.

Maker	Frequency	Type	Remarks
Simrad	38 kHz	38E-9-18S1 (2kW)	
Airmar	38 kHz	38E-M42 (3 kW)	
Honda	36 kHz	32/40 (3 kW)	
	41 kHz	40/75 (3 kW)	
	50 kHz	50/200/400 (2 kW)	
		50/3K/3F (3 kW)	
	67 kHz	40/75 (3 kW)	
	200 kHz	50/200/400 (2 kW)	
Suzuki	50, 200 kHz	TGM50/200	Same as Furuno makes 50/200-1T (1 kW)

Entering transducer data by transducer model number

Note 1: If you are continuing from paragraph 3.1 go to step 2.

Note 2: If you have already entered transducer settings and to reconfirm them turn on the power while pressing any key.

1. Turn on the power.
2. Press any key to show the following menu.

XDCR SELECT	INSTALLATION	DEMO
XDCR SELECT : XDCR TYPE		
[HIGH]		
CONNECTION	:	NOT CONNECTED
FREQ	:	--kHz
TRANSDUCER	:	----
TAP	:	--
[LOW]		
CONNECTION	:	NOT CONNECTED
FREQ	:	--- kHz
TRANSDUCER	:	----
TAP	:	--
POWER REDUCTION : OFF		
[-/+]: Change setting, Turn OFF to exit		

Installation main menu

Note: XDCR SETTING is set to “XDCR TYPE” at the default setting.

3. INITIAL SETTINGS

3. Press [▼] to select [HIGH] CONNECTION or [LOW] CONNECTION (whichever is installed), and then press [+] or [-] to show the dialog box. Select CONNECTED for the connection of transducer.
4. Press [▲] or [▼] to close the dialog box.
5. Press [▼] to select FREQ.
6. Press [+] or [-] to show the dialog box. The scroll bar at the bottom of the dialog box shows cursor position in relation to the entire menu.

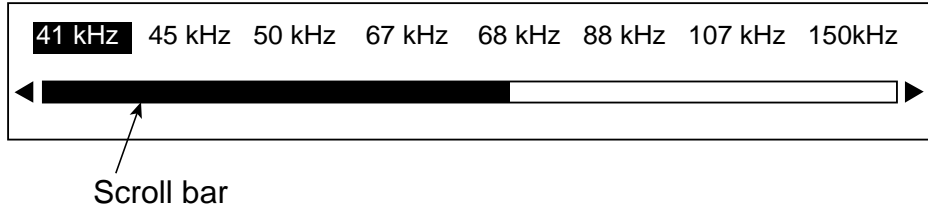

7. Press [+] or [-] to select frequency, (HIGH: 41 kHz and higher, LOW: 28 kHz and higher are available.) and then press [▲] or [▼] to close the dialog box.
8. Press [▼] to select TRANSDUCER, and then press [+] or [-] to open the dialog box.

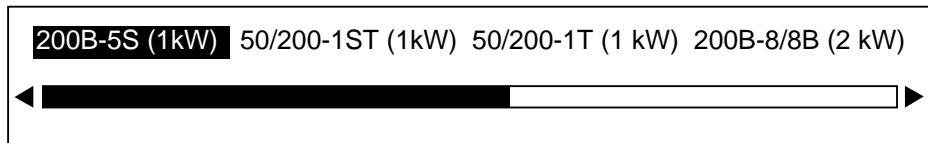

Dialog box for 200 kHz

9. Press [+] or [-] to select model number, and then press [▲] or [▼] to close the dialog box.
10. Jot down alphabet which appears on "TAP" line. You may change the terminal board setting at the rear of the display unit depending on the transducer type which is connected. For details, see page 3-5.
11. Follow steps 3-10 to enter model number of other transducer if installed.
Note: For dual-frequency transducer, enter both high and low frequencies and set the same transducer model number for both high and low frequencies.
12. Press [▼] to select PWR REDUCTION, and then press [+] or [-] to open the dialog box.



13. Press [+] or [-] to turn the power reduction ON or OFF (default setting).
14. Press [▲] or [▼] to close the dialog box.
15. Confirm settings and turn off the power.

Note: If the system detects frequency mismatch the message "Frequency unmatched error! Press any key to go to Transducer setting menu." appears at the next powering of the equipment. Press any key to go to the transducer setting menu and reenter transducer data.

Transducer setting

Change the terminal board setting at the rear of the display unit according to the transducer connected.

Note the alphabet which appeared when selecting the transducer type on the installation main menu (page 3-4), and then do the following procedures.

1. Dismount the display unit from the mounting place.
2. Loosen four screws to remove the rear cover.

Note: There is no gasket for lid. (The groove around the terminal board does not hold a gasket.)

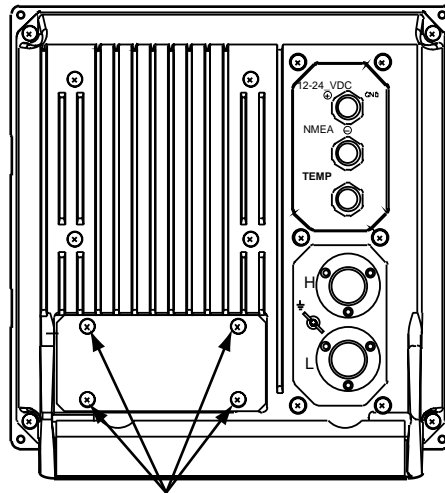

Loosen these screws.

Display unit, rear view

3. Fasten the crimp-on lug to the appropriate terminal according to alphabet appearing on the installation menu.

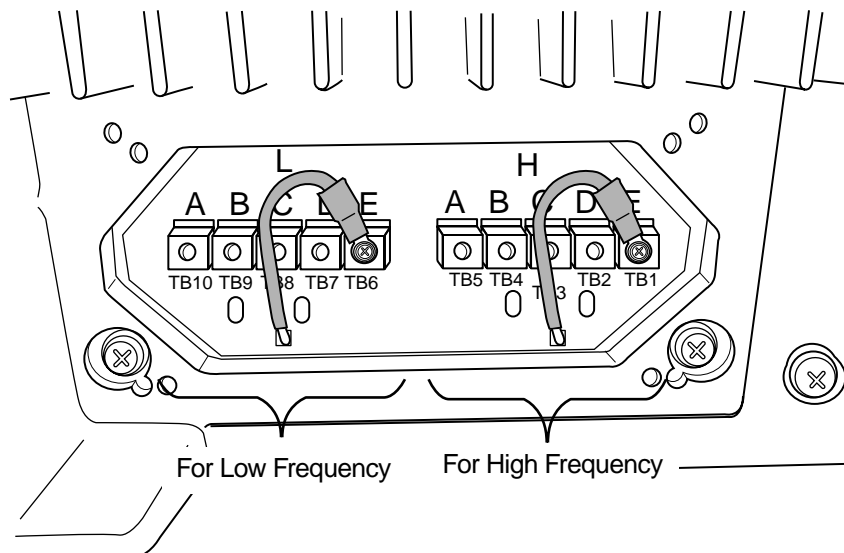

Terminal board

4. Remount the display unit.

3. INITIAL SETTINGS

Entering transducer data by transducer specifications

For dealer: When connecting the transducers which are not programmed, contact to PRODUCT SERVICE SECTION SERVICE CENTER, FURUNO HEAD OFFICE. For new transducer or other make of transducer see FURUNO information for further information.

Note 1: If you are continuing from paragraph 3.1, go to step 2.

Note 2: If you have already entered transducer settings and wait to reconfirm them turn on the power while pressing any key.

Note 3: The transducers of 54 – 64 kHz, 112 – 122 kHz and 171 – 181 kHz cannot be connected to the FCV-1100L because of noise. (Available range: HIGH; 40 – 220 kHz, LOW; 25 –220 kHz).

1. Turn on the power.
2. Press any key.
3. Press [▼] to select XDCR SELECT, and then press [+] or [-] to show the dialog below.

XDCR TYPE MANUAL

4. Press [+] to select MANUAL, and then press [▲] or [▼] to close the dialog box. The display should now look something like the one below.

XDCR SELECT INSTALLATION DEMO
XDCR SELECT : MANUAL
[HIGH] CONNECTION : NOT CONNECTED FREQ : ---kHz
[LOW] CONNECTION : NOT CONNECTED FREQ : --- kHz
POWER REDUCTION : OFF
Select how to set XDCR type. [-/+]: Change setting, Turn OFF to exit

Menu for manual entry of transducer specifications

5. Do the following for both the high and low frequency transducers, or whichever transducer is installed.
 - a) Press [▼] to select CONNECTION of [HIGH] or [LOW], and then press [+] or [-] to open the dialog box.

NOT CONNECTED **CONNECTED**

- b) Use [+] or [-] to select CONNECTED, and then press [▲] or [▼] to close the dialog box.
- c) Press [▼] to select FREQ, and press [+] or [-] to display the frequency setting dialog box.

--- kHz

- d) Use [+] or [-] to set the value for the frequency which is connected, and then press [▲] or [▼] to close the dialog box. (Available range: HIGH; 40 – 220 kHz, LOW; 25 – 220 kHz)
- e) To operate the transducer in reduced power (for example, when vessel is in dry dock), press [▼] to select PWR REDUCTION, and then press [+] or [-] to open the dialog box.



- f) Press [+] or [-] to turn the power reduction ON, and then press [▲] or [▼] to close the dialog box.
6. Confirm settings and turn off the power.

3.3 Water Temperature Sensor Setting

If a water temperature sensor is connected, set up as follows:

1. Turn on the power and turn the [FUNCTION] switch to the MENU position.
2. Press [▲] and [+] to select SYSTEM at the top of the screen.
3. Press [▼] to select TEMP SETTING, and then press [+] to open that menu.

DISP	ALM	TX/RX	E/S	SYSTEM
TEMP SETTING				
TEMP UNIT	:	°F		
TEMP INPUT	:	SENSOR		
TEMP ADJUST	:	+0.00°F (-20~+20)		
TEMP OUTPUT	:	OFF		
TEMP READOUT	:	OFF		
TEMP GRAPH	:	OFF		
TEMP COLOR	:	STD		
Select temperature unit.				
[-/+]: Change set, [EXIT]: Exit				

TEMP SETTING menu

4. The cursor is selecting TEMP UNIT; press [+] or [-] to open the dialog box.



5. Press [+] or [-] to select the temperature unit, and then press [▲] or [▼] to close the dialog box.

3. INITIAL SETTINGS

6. Press [▼] to select TEMP INPUT, and then press [+] or [-] to open the dialog box.

SENSOR NMEA

7. Use [+] or [-] to select source of water temperature data, and then press [▲] or [▼] to close the dialog box.

SENSOR: Water temperature sensor T-02MSB, T-02MTB or T-03MSB inputs water temperature data. This is the default setting.

NMEA: Water temperature data input from external equipment.

8. When selecting SENSOR at TEMP INPUT, you may offset water temperature data to further refine its accuracy. This must be done with the boat in water.

- a) Press [▼] to select TEMP ADJUT, and then press [+] or [-] to open the dialog box.

+0.00

- b) Watch the water temperature readout on the monitor (if it is not displayed set TEMP READOUT to ON) and compare it with known value.
- c) Use [+] or [-] to enter the difference found in b) above. For example, if the indication of the FCV-1100L is +5° higher than the actual value, enter -5 (degree).
- d) Press [▲] or [▼] to close the dialog box.

9. Press [▼] to select TEMP OUTPUT, and then press [+] or [-] to open the dialog box.

OFF ON

10. Use [-] or [+] to turn the water temperature indication (NMEA) ON or OFF respectively, and then press [▲] or [▼] to close the dialog box.

11. Press [▼] to select TEMP READOUT, and then press [+] to open the dialog box.

OFF ON

12. Use [-] or [+] to select the temperature display, and press [▲] or [▼] to close the dialog box.

13. Press [▼] to select TEMP GRAPH and [+] or [-] to open the dialog box.

OFF NARROW STD EXPAND

14. Press [+] or [-] to select temperature scale graduation interval, and then press [▲] or [▼] to close the dialog box.

15. Press [▼] to select TEMP COLOR and [+] or [-] to open the dialog box.

STD WHITE RED BLACK YELLOW

16. Use [+] or [-] to select the color of the water temperature graph for STD (blue in default setting but then press [▲] or [▼] to close the dialog box.

17. Turn the [FUNCTION] switch to EXIT position to quit.

3.4 Nav Data, Heading Sensor Setting

Select navigator and heading sensor used as below.

1. Turn on the power and turn the [FUNCTION] switch to the MENU position.
2. Press [\blacktriangle] and [+] to select SYSTEM at the top of the screen.
3. Press [\blacktriangledown] to select NAV DATA SETTING, and then press [+] to open that menu. (If a heading sensor is connected but not a navigator, go to step 18.)

DISP ALM TX/RX E/S	SYSTEM
NAV DATA SETTING	
SPEED UNIT	: kt
SPEED INPUT	: SENSOR
SPEED ADJUST	: +0% (-50~+50)
SPEEDOUTPUT	: ON
SPEED INFO	: OFF
NMEA VERSION	: Ver 2.0
NAV DATA	: AUTO
COURSE	: TRUE
TLL OUTPUT	: OFF
Select speed unit.	
[-/+]: Change set, [EXIT]: Exit	

NAV DATA SETTING menu

4. The cursor is selecting SPEED UNIT; press [+] or [-] to open the dialog box.

kt km/h MPH

5. Use [-] or [+] to select the speed unit, and then press [\blacktriangle] or [\blacktriangledown] to close the dialog box.
6. Press [\blacktriangledown] to select SPEED INPUT, and then press [+] or [-] to open the dialog box.

SENSOR NMEA

7. Use [+] or [-] to select the source of speed data, and then press the [\blacktriangle] or [\blacktriangledown] to close the dialog box.

SENSOR: Speed/temperature sensor

NMEA: Speed data input from the equipment connected.

8. Press [\blacktriangledown] to select SPEED ADJUST, and the press [+] to open the dialog box.

+0.0

9. You may offset speed data to further refine its accuracy. This is not possible when the speed input is "NMEA".
 - a) Watch the speed sensor readout on the monitor (if it is not displayed set SPEED INFO to ON) and compare it with known value.
 - b) Use [+] or [-] to enter the difference found in a) above. For example, if the indication of the FCV-1100L is +5 % faster than the actual value, enter -5.

3. INITIAL SETTINGS

$$\text{Adjustment value} = \frac{\text{Actual value} - \text{Indication of FCV-1100L}}{\text{Actual value}} \times 100 (\%)$$

c) Press [\blacktriangle] or [\blacktriangledown] to close the dialog box.

10. Press [\blacktriangledown] to select SPEED OUTPUT, and then press the [+] or [-] key to open the dialog box.

OFF ON

11. Use [+] or [-] to turn the speed output ON (default setting) or OFF, and press [\blacktriangle] or [\blacktriangledown] to close the dialog box.

12. Press [\blacktriangledown] to select SPEED INFO, and then press [+] or [-] to open the dialog box.

OFF ON

13. Press [+] or [-] to turn the speed indication (NMEA) OFF (default setting) or ON, and then press [\blacktriangle] or [\blacktriangledown] to close the dialog box. If no navigator is connected, turn the [FUNCTION] switch to other position to quit.

14. Press [\blacktriangledown] to select NMEA VERSION, and then press [+] or [-] to open the dialog box.

Ver 1.5 **Ver 2.0** Ver 3.0 SPECIAL

15. Use [+] or [-] to select NMEA version no. (default setting is Ver 2.0) of the navigator, and then press [\blacktriangle] or [\blacktriangledown] to close the dialog box. If you are unsure of the version no., try all three to see which one successfully receives position data. SPECIAL is for use with a navigator whose baud rate is 600 bps.

16. Press [\blacktriangledown] to select NAV DATA, and then press [+] or [-] to open the dialog box.

LC LA DECCA GPS DR **AUTO**

17. Use [+] to select type of navigator connected, and then press [\blacktriangle] or [\blacktriangledown] to close the dialog box. AUTO (default setting) selects a navigator in the order of GPS, Loran C, Loran A, Decca, DR (Dead Reckoning).

18. Press [\blacktriangledown] to select COURSE, and then press [+] or [-] to open the dialog box.

TRUE MAG

19. Use [+] or [-] to select TRUE or MAG (magnetic bearing) as appropriate, and then press [\blacktriangle] or [\blacktriangledown] to close the dialog box. TRUE is the default setting.

20. Press [\blacktriangledown] to select TLL (Target latitude, Longitude) OUTPUT, and then press [+] or [-] to open the dialog box.

OFF ON

21. TLL OUTPUT enables or disables output of position data from the video sounder to external equipment, at the moment the [MARKER TLL] key is pressed. Use [+] or [-] to select ON or OFF (default setting) as appropriate, and then press [\blacktriangle] or [\blacktriangledown] to close the dialog box.

22. Turn the [FUNCTION] switch to EXIT position to quit.

3.5 Propagation Velocity

This section provides the information for adjustment of propagation velocity. Normally, no adjustment is necessary, however if the depth indication is wrong, lower or raise propagation velocity as appropriate.

1. Turn on the power while pressing any key to show the installation main menu.
2. Press [+] or [-] to select INSTALLATION.

XDCR SETTING	INSTALLATION	DEMO
SOUND SPEED	: 1500.0 m/s (200~2000)	
INVERTER FREQ	: LO (59/118/177 kHz)	
[-/+]: Change setting, Turn OFF to exit		

INSTALLATION menu

3. Press [▼] to select SOUND SPEED, and then press [+] or [-] to open the dialog box.

1500.0 m/s

4. Use [+] or [-] to enter value, and then press [▲] or [▼] to close the dialog box. The default setting is 1500.0 (m/s) and the setting range is 200-2000 (m/s).
5. Turn off the power to quit.

3.6 Demonstration Mode

The demonstration mode provides a simulated video sounder picture. Connection of the transducer is not necessary. All controls are operational.

1. Turn on the power while pressing any key to display the installation main menu.
2. Press [+] to select DEMO.

XDCR SETTING INSTALLATION DEMO
DEMO MODE : OFF
[-/+] : Change setting, Turn OFF to exit

DEMO menu

3. Press [▼] to select DEMO MODE, and then press [+] or [-] to open the dialog box.

OFF ON

4. Use [+] or [-] to select ON or OFF (default setting) as appropriate, and then press [▲] or [▼] to close the dialog box.
5. Turn off the power.
6. Turn on the power again after five seconds. "<DEMO>" appears at the bottom of the screen when the demonstration mode is on.

3.7 Restoring Default Settings

The procedure below restores most default settings. Are not affected: target setting, language, demo mode, transducer settings, user color settings and user clutter settings.

1. Turn on the power and turn the [FUNCTION] switch to the MENU position.
2. Press [\blacktriangle] and [+] to select SYSTEM at the top of the screen.
3. Press [\blacktriangledown] to select DEFAULT SETTING, and then press [+] key.

DISP ALM TX/RX E/S SYSTEM
DEFAULT SETTING
DEFAULT SET : NO
[+/-]: Change set, [EXIT]: Exit

4. Press [+] or [-] to open the dialog box.

[-]: NO [+] : YES

5. Press [+] to restore default settings.
6. Three beeps sound and then normal operation is restored.

This page is intentionally left blank.

APPENDIX 1

TRANSDUCER 50BL-12/50BL-24H

When using the transducer 50BL-12/50BL-24H, see this appendix.

Transducer, thru-hull pipe and tank list

Frequency (kHz)	Transducer	Hull Material	Tank (Code No.)	Fasten inside hull (Code No.)	Fasten outside hull (Code No.)
50/200	50BL-12/200B-8B	Steel	T-693 (000-015-044)	TWB-6000 (000-015-207)	TFB-7000 (000-015-209)
		FRP	T-693F (000-015-241)	TWB-1100 (000-015-218)	-
28/50	28F-24H/50BL-24H	Steel	T-696 (000-015-048)	TWB-6000 (000-015-207)	TFB-7000 (000-015-209)
		FRP	T-696F (000-015-244)	TRB-1100 (000-015-218)	-
50/88	50BL-24H/88F-126H	Steel	T-697 (000-015-239)	TWB-6000 (000-015-207)	TFB-7000 (000-015-209)
		FRP	T-697F (000-015-245)	TRB-1100 (000-015-218)	-
50/200	50BL-24H/200B-12H	Steel	T-695 (000-015-047)	TWB-6000 (000-015-207)	TFB-7000 (000-015-209)
		FRP	T-695F (000-015-243)	TRB-1100 (000-015-218)	-

Settings

- Referring page 3-6, set the menu as below.
 XDCR SELECT: MANUAL
 FREQ: 50 kHz
- At the terminal board at the rear of the display unit, fasten the crimp-on lug to C position.
 (See page 3-5.)

Frequency	Output (kW)	Transducer	Terminal
50	2	50BL-12	C
	3	50BL-24H	C

APPENDIX 2

NEW BLT TRANSDUCERS

A new type BLT transducer (Bolt-clamp Langevin Transducer) has been developed for this echo sounder. The BLT transducer has large bandwidth, good sound efficiency, compact structure and is reinforced for protection against slamming.

Transducer, thru-hull pipe and tank list

Frequency (kHz)	Transducer	Hull Material	Tank (Code No.)	Fasten inside hull (Code No.)	Fasten outside hull (Code No.)
28/200	28BL-6HR/200B-8B	Steel	T-693 (000-015-044)	TWB-6000 (2) (000-015-207)	TFB-7000 (2) (000-015-209)
		FRP	T-693F (000-015-241)	TRB-1100 (2) (000-015-219)	-
38/200	38BL-9HR/200B-8B	Steel	T-693 (000-015-044)	TWB-6000 (2) (000-015-207)	TFB-7000 (2) (000-015-209)
		FRP	T-693F (000-015-241)	TRB-1100 (2) (000-015-219)	-
50/200	50BL-12HR/200B-8B	Steel	T-693 (000-015-044)	TWB-6000 (2) (000-015-207)	TFB-7000 (2) (000-015-209)
		FRP	T-693F (000-015-241)	TRB-1100 (2) (000-015-219)	-
28/38	28BL-12HR/38BL-15HR	Steel	T-681 (000-015-849)	TWB-6000 (2) (000-015-207)	TFB-7000 (2) (000-015-209)
		FRP	T-681F (000-015-850)	TRB-1100 (2) (000-015-219)	-
28/50	28BL-12HR/50BL-24HR	Steel	T-681 (000-015-849)	TWB-6000 (2) (000-015-207)	TFB-7000 (2) (000-015-209)
		FRP	T-681F (000-015-850)	TRB-1100 (2) (000-015-219)	-
38/50	38BL-15HR/50BL-24HR	Steel	T-681 (000-015-849)	TWB-6000 (2) (000-015-207)	TFB-7000 (2) (000-015-209)
		FRP	T-681F (000-015-850)	TRB-1100 (2) (000-015-219)	-
28/88	28BL-12HR/88F-126H	Steel	T-682 (000-015-851)	TWB-6000 (2) (000-015-207)	TFB-7000 (2) (000-015-209)
		FRP	T-682F (000-015-852)	TRB-1100 (2) (000-015-219)	-
38/88	38BL-15HR/88F-126H	Steel	T-682 (000-015-851)	TWB-6000 (2) (000-015-207)	TFB-7000 (2) (000-015-209)
		FRP	T-682F (000-015-852)	TRB-1100 (2) (000-015-219)	-

50/88	50BL-24HR/88-126H	Steel	T-682 (000-015-851)	TWB-6000 (2) (000-015-207)	TFB-7000 (2) (000-015-209)
		FRP	T-682F (000-015-852)	TRB-1100 (2) (000-015-219)	-
28/200	28BL-12HR/200B-12H	Steel	T-683 (000-015-853)	TWB-6000 (2) (000-015-207)	TFB-7000 (2) (000-015-209)
		FRP	T-683F (000-015-854)	TRB-1100 (2) (000-015-219)	-
38/200	38BL-15HR/200B-12H	Steel	T-683 (000-015-853)	TWB-6000 (2) (000-015-207)	TFB-7000 (2) (000-015-209)
		FRP	T-683F (000-015-854)	TRB-1100 (2) (000-015-219)	-
50/200	50BL-24HR/200B-12H	Steel	T-683 (000-015-853)	TWB-6000 (2) (000-015-207)	TFB-7000 (2) (000-015-209)
		FRP	T-683F (000-015-854)	TRB-1100 (2) (000-015-219)	-
28/150	28BL-12HR/150B-12H	Steel	T-683 (000-015-853)	TWB-6000 (2) (000-015-207)	TFB-7000 (2) (000-015-209)
		FRP	T-683F (000-015-854)	TRB-1100 (2) (000-015-219)	-
38/150	38BL-15HR/150-12H	Steel	T-683 (000-015-853)	TWB-6000 (2) (000-015-207)	TFB-7000 (2) (000-015-209)
		FRP	T-683F (000-015-854)	TRB-1100 (2) (000-015-219)	-
38/150	50BL-24HR/156-12H	Steel	T-683 (000-015-853)	TWB-6000 (2) (000-015-207)	TFB-7000 (2) (000-015-209)
		FRP	T-683F (000-015-854)	TRB-1100 (2) (000-015-219)	-

Settings

- Referring page 3-6, set the menu as below.

XDCR SELECT: MANUAL
 FREQ: 28/38/50 kHz

Transducer	Output	Tap
28BL-6HR	2	C
38BL-9HR		C
50BL-12HR		C
28BL-12HR	3	D
38BL-15HR		E
50BL-24HR		E

APPENDIX 2 NEW BLT TRANSDUCERS

This page is intentionally left blank.

PACKING LIST

FCV-1100L

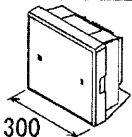
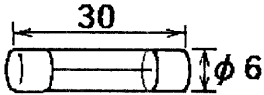
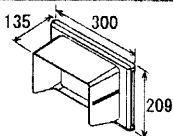
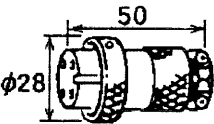
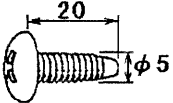
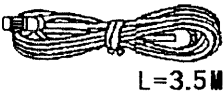
NAME	OUTLINE	DESCRIPTION/CODE No.	Q'TY
ユニット UNIT			
指示器 DISPLAY UNIT		CV-1100L 000-002-538	1
予備品 SPARE PARTS		SP02-04401	
ヒューズ FUZE		FGBO-A 5A AC125V 000-549-064	3
付属品 ACCESSORIES		FP02-05300	
フード組品 HOOD ASSY.		FP02-05301 001-402-110	1
工事材料 INSTALLATION MATERIALS		CP02-06901	
コネクタ(NCS) CONNECTOR		NCS-254-P 000-506-505	2
+トラスタップピンネジ +TAPPING SCREW		5X20 SUS304 1ヶ 000-802-081	4
その他工材 OTHER INSTALLATION MATERIALS			
ケーブル組品MJ CABLE ASSY.		MJ-A3SPF0013-035 000-129-613	1

(略図の寸法は、参考値です。 DIMENSIONS IN DRAWING FOR REFERENCE ONLY.)

DWG. NO.

C2367-Z01-A

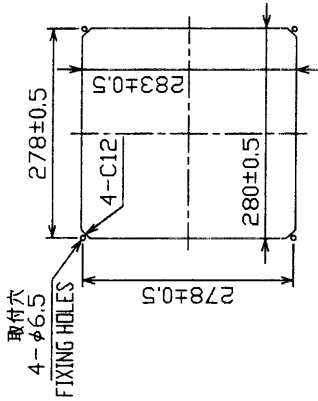
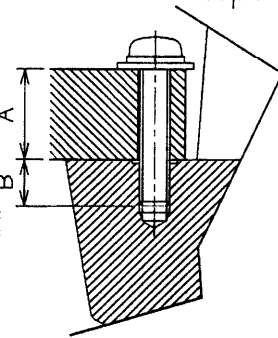
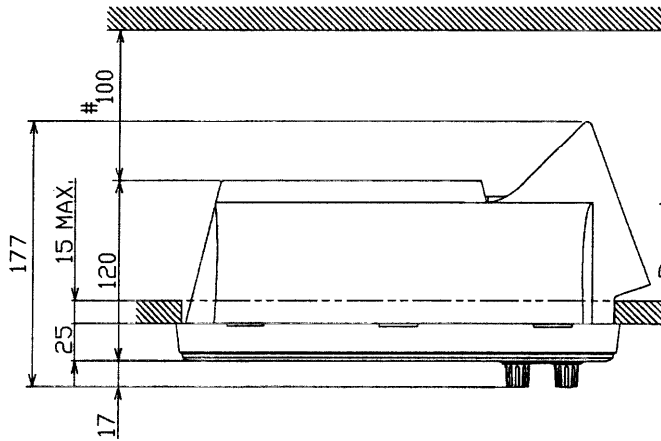
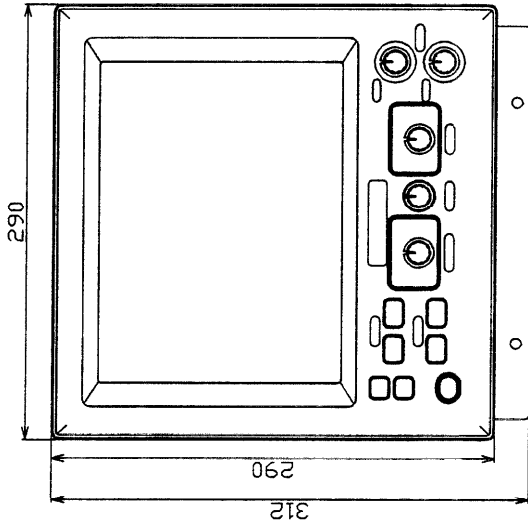
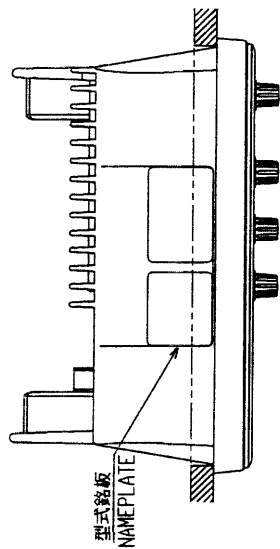

取付穴寸法図(尺度 1/10)
CUTOUT DIMENSIONS (SCALE 1/10)

寸法区分 (mm) DIMENSION	公差 (mm) TOLERANCE
L ≤ 50	±1.5
50 < L ≤ 100	±2.5
100 < L ≤ 500	±3

表 1
TABLE 1

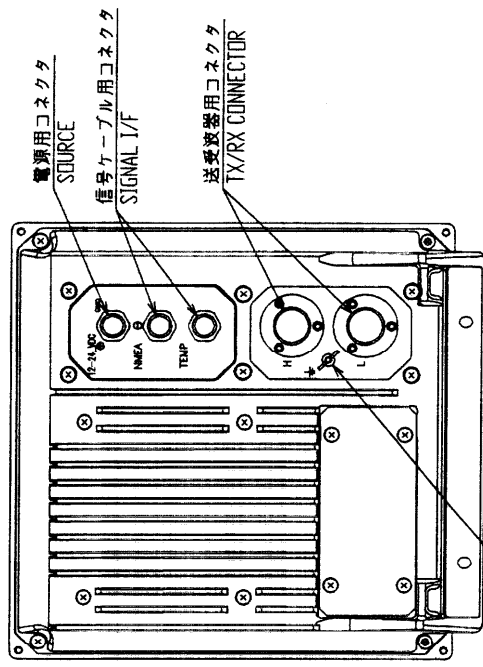

7-入端子
GND TERMINAL
背面図
REAR VIEW

取付ネジ部断面 (尺度 1/1)
DETAIL OF FIXING (SCALE 1/1)

- 注 記
- 1) #印寸法は最小サービス空間寸法とする。
 - 2) 指定外の寸法公差は表1による。
 - 3) 取付用ネジはセムスネジB M5×20を使用のこと。壁の厚さ(A)は11 ≤ A ≤ 14。これ以外の壁に装着する場合、ネジ長さは(A+7.3) ± 1.5(セムスネジB)とする。筐体にはネジ部を7mm以上いれないこと。(B部)

- NOTE
1. # RECOMMENDED SERVICE CLEARANCE.
 2. TABLE 1 INDICATES TOLERANCE OF DIMENSIONS.
 3. USE TAPPING SCREWS M5x20 FOR FIXING THE UNIT. THICKNESS A: 11 ≤ A ≤ 14 OR SCREW LENGTH: (A+7.3) ± 1.5. DO NOT FASTEN SCREWS INTO UNIT MORE THAN 7 mm.(B ≤ 7)

DRAWN Aug. 21 '01 I. YAMASAKI	TITLE CV-1100L
CHECKED AUG 21 2001 Y. T.	名称 指示部 (埋込装備)
APPROVED 2001.08.21 Y. K.	外寸図
SCALE 1/5	NAME DISPLAY UNIT (FLUSH MOUNT)
DWG No. 02367-002-B	INTERCONNECTION DIAGRAM 02-137-120G-1



表1 TABLE 1

寸法区分(mm) DIMENSION	公差(mm) TOLERANCE
0 < L ≤ 50	±1.5
50 < L ≤ 100	±2.5
100 < L ≤ 500	±3

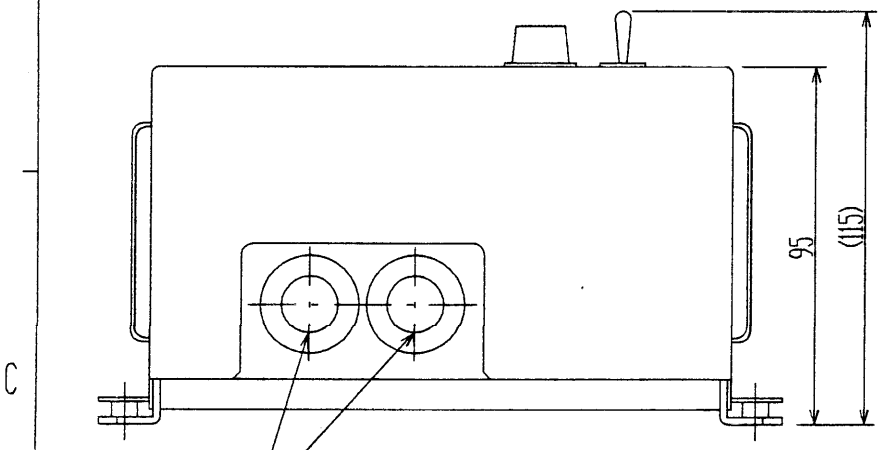
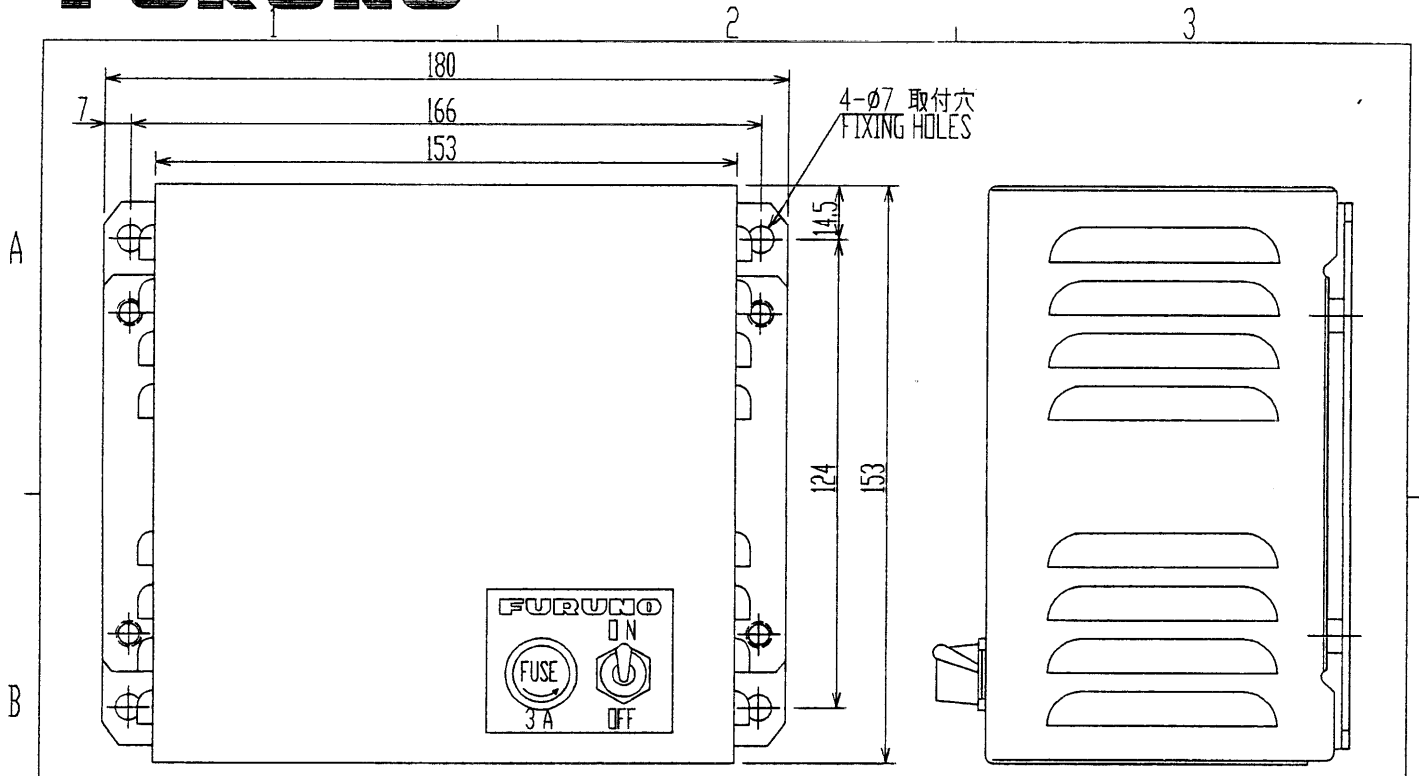
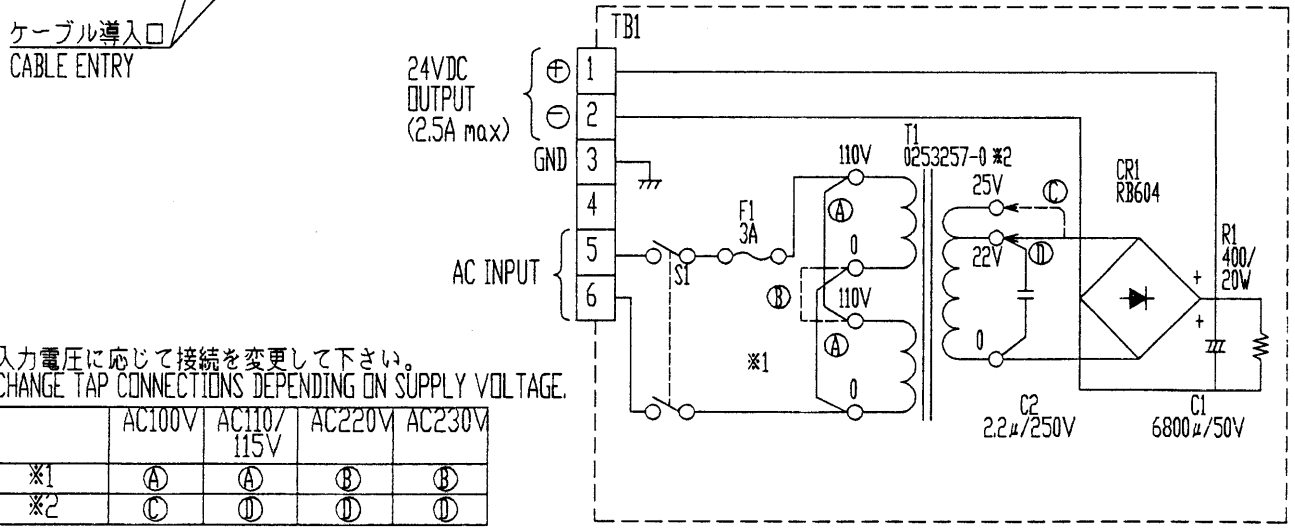

入力電圧に応じて接続を変更して下さい。
CHANGE TAP CONNECTIONS DEPENDING ON SUPPLY VOLTAGE.

	AC100V	AC110/ 115V	AC220V	AC230V
*1	(A)	(A)	(B)	(B)
*2	(C)	(D)	(D)	(D)

DRAWN Sep. 14 '01 T.YAMASAKI	TITLE PR-62
CHECKED Y.Ki	名称 整流器
APPROVED Y.Ki	外寸図
SCALE 1/2 MASS 3 ±10% kg	NAME RECTIFIER
DWG.No. C5003-034-E	OUTLINE DRAWING

表1 TABLE 1

寸法区分(mm) DIMENSION	公差(mm) TOLERANCE
0 < L ≤ 50	±1.5
50 < L ≤ 100	±2.5

A

B

C

D

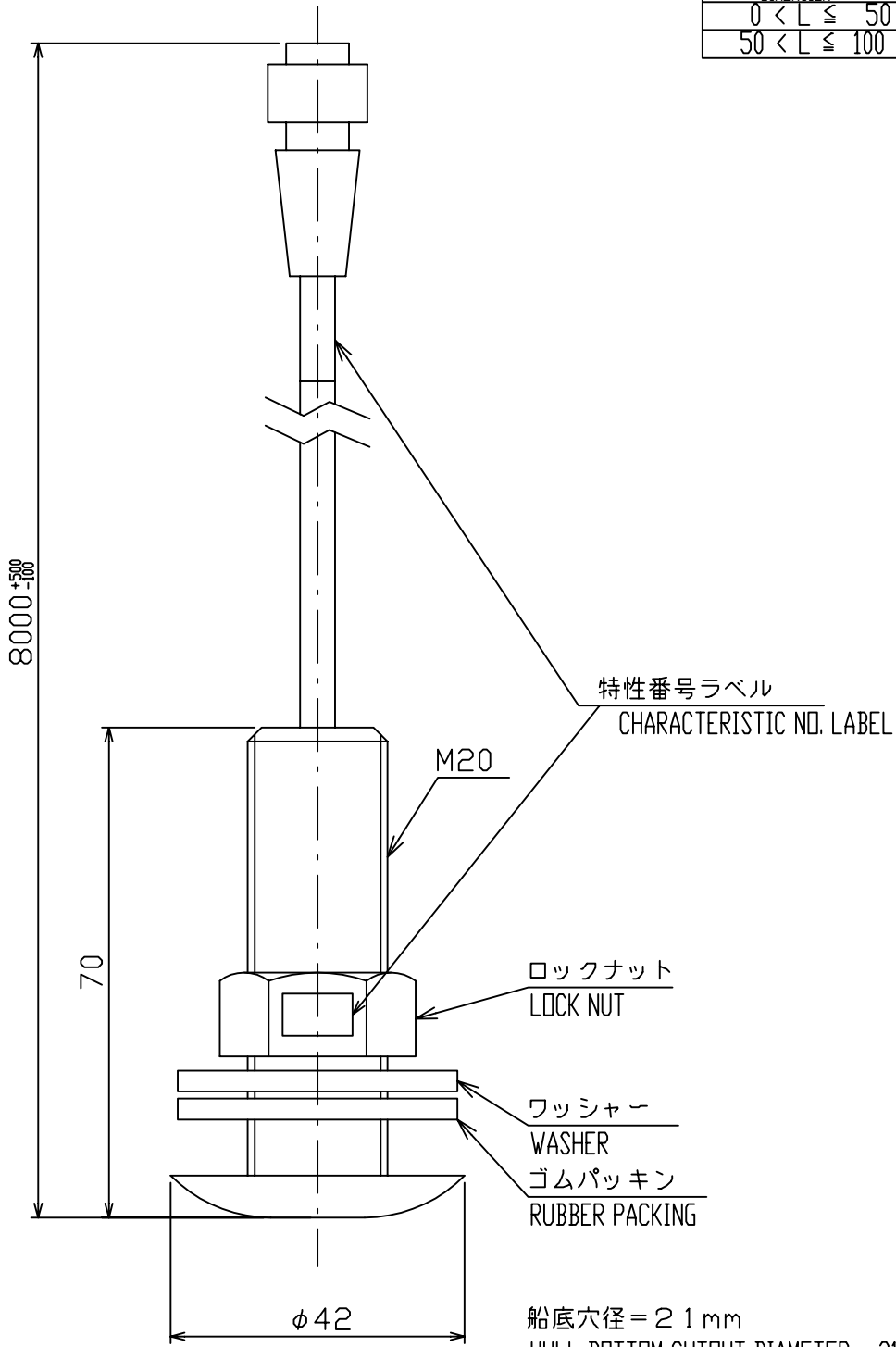

注記

1) 指定なき寸法公差は表1による。

NOTE

1. TABLE 1 INDICATES TOLERANCE OF DIMENSIONS.

DRAWN Nov. 14 '02 T.YAMASAKI	TITLE T-02MSB
CHECKED Nov. 14 '02 Y.KIMURA	名称 水温センサー
APPROVED Nov. 14, '02 <i>Y. Kimura</i>	外寸図
SCALE 1/1	NAME THERMO SENSOR
MASS 0.5 ±10% kg	OUTLINE DRAWING
DWG.No. C4322-007-C	

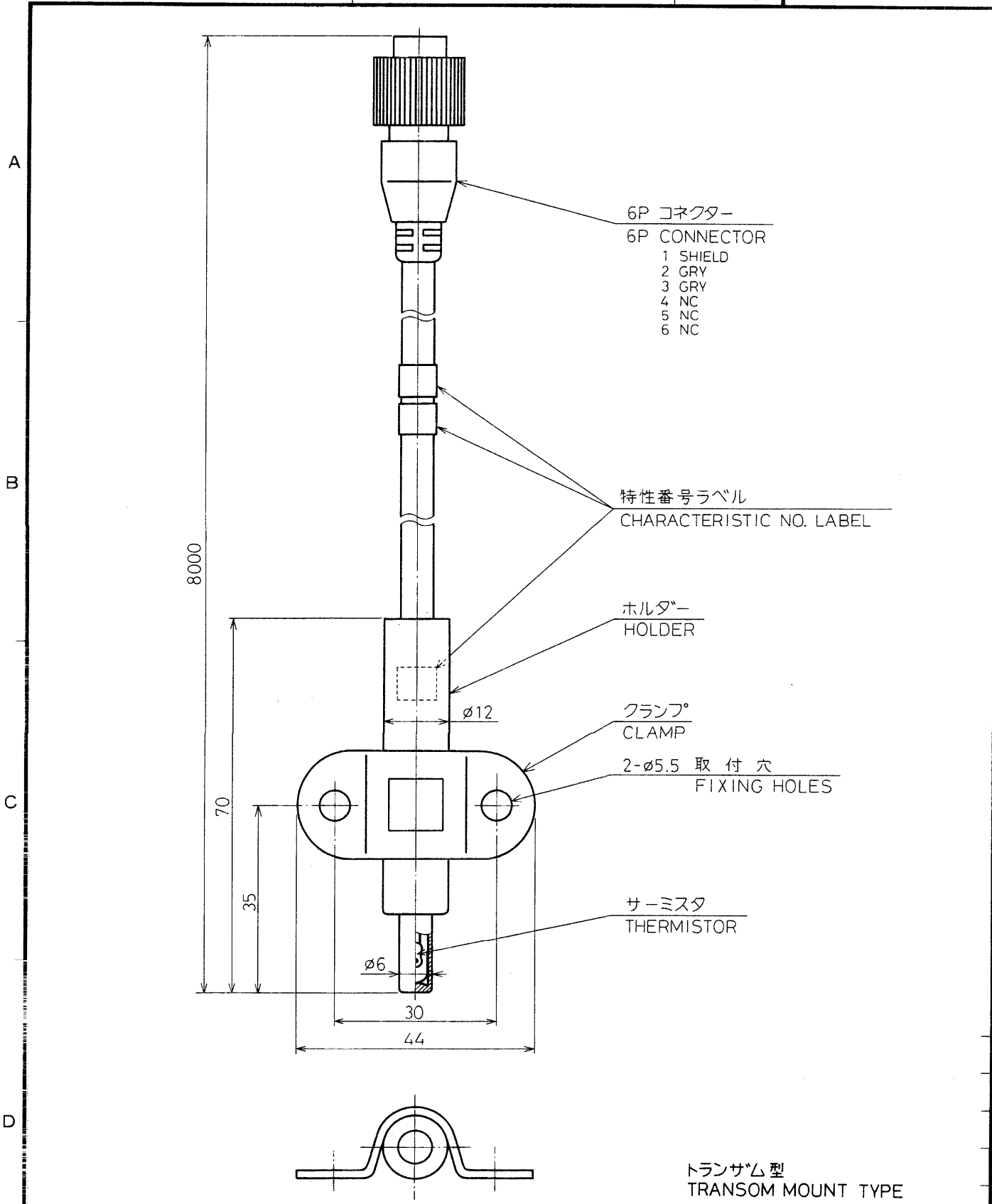

品番 ITEM	品名 NAME	材質 MATERIAL	数量 Q'TY	図番 DWG.NO.	摘要 REMARKS
承認 APPROVED	FEB. 28. 89 T. NAKANO	三角法 THIRD ANGLE PROJECTION	名称 TITLE	T-02MTB 水温センサー TEMPERATURE SENSOR	
検図 CHECKED	Feb. 28. 89 T. KODRA	尺度 SCALE	1/1		
製図 DRAWN	Feb. 28. 89 T. MIYOSHI	質量 MASS	kg	図番 DWG.NO.	C2317-G01-B

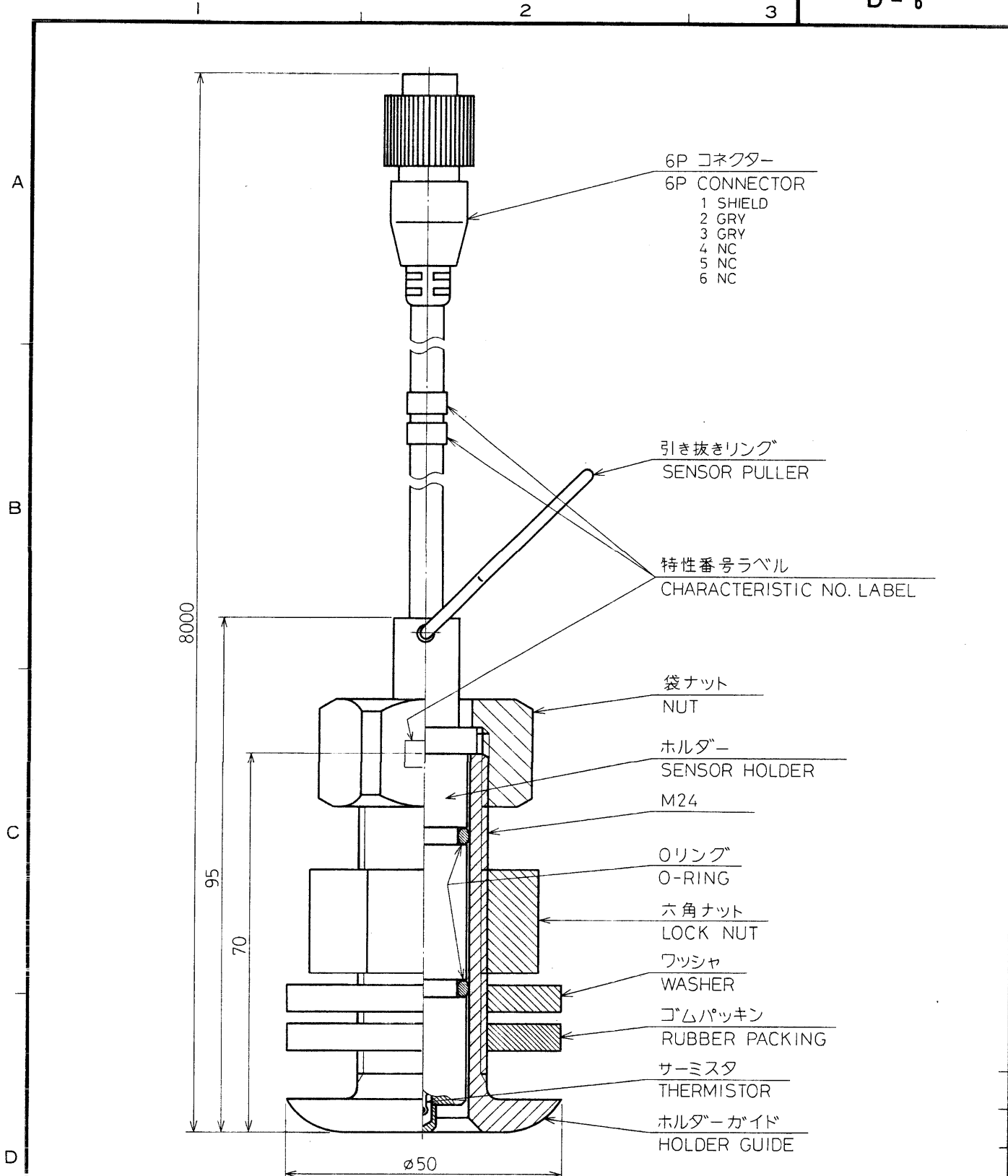

船底貫通型 (取り外し可能)
THRU HULL MOUNT

品番 ITEM	品名 NAME	材質 MATERIAL	数量 Q'TY	図番 DWG.NO.	摘要 REMARKS
承認 APPROVED	FEB. 28. 89 T. WAKANO	三角法 THIRD ANGLE PROJECTION	名称 TITLE	T-03MSB 水温センサー TEMPERATURE SENSOR	
検図 CHECKED	Feb. 28. 89 T. KODA	尺度 SCALE	1 / 1		
製図 DRAWN	Feb. 28. 89 T. MIYOSHI	質量 MASS	kg	図番 DWG.NO.	C2317-G02-B

Free Manuals Download Website

<http://myh66.com>

<http://usermanuals.us>

<http://www.somanuals.com>

<http://www.4manuals.cc>

<http://www.manual-lib.com>

<http://www.404manual.com>

<http://www.luxmanual.com>

<http://aubethermostatmanual.com>

Golf course search by state

<http://golfingnear.com>

Email search by domain

<http://emailbydomain.com>

Auto manuals search

<http://auto.somanuals.com>

TV manuals search

<http://tv.somanuals.com>