

FURUNO

INSTALLATION MANUAL

COLOR SCANNING SONAR

MODEL CSH-23/23F/24/24F



FURUNO ELECTRIC CO., LTD.
NISHINOMIYA, JAPAN



(Elemental Chlorine Free)

The paper used in this manual
is elemental chlorine free.

© **FURUNO ELECTRIC CO., LTD.**

9-52 Ashihara-cho,
Nishinomiya 662-8580, JAPAN

Telephone : 0798-65-2111

Fax : 0798-65-4200

FURUNO Authorized Distributor/Dealer

All rights reserved.

Printed in Japan

FIRST EDITION : NOV. 1997

J3 : OCT. 05, 2006

Pub. No. IME-13040-J3

(TATA) CSH-23/24/F



* 0 0 0 8 0 8 0 6 9 0 3 *



* I M E 1 3 0 4 0 J 3 0 *



SAFETY INSTRUCTIONS



WARNING



Do not open the cover unless totally familiar with electrical circuits and service manual.

High voltage exists inside the equipment, and a residual charge remains in capacitors several minutes after the power is turned off. Improper handling can result in electrical shock.

Turn off the power at the switchboard before beginning the installation.

Fire or electrical shock can result if the power is left on.

Do not install the equipment where it may get wet from rain or water splash.

Water in the equipment can result in fire, electrical shock or equipment damage.

Be sure no water leaks in at the transducer installation site.

Water leakage can sink the vessel. Also confirm that the transducer will not loosen by ship's vibration. The installer of the equipment is solely responsible for the proper installation of the equipment. FURUNO will assume no responsibility for any damage associated with improper installation.



WARNING

Install the specified transducer tank in accordance with the installation instructions. If a different tank is to be installed the shipyard is solely responsible for its installation, and it should be installed so the hull will not be damaged if the tank strikes an object.

The tank or hull may be damaged if the tank strikes an object.

If a steel tank is installed on a wooden or FRP vessel, take appropriate measures to prevent electrolytic corrosion.

Electrolytic corrosion can damage the hull.

Be sure that the power supply is compatible with the voltage rating of the equipment.

Connection of an incorrect power supply can cause fire or equipment damage. The voltage rating of the equipment appears on the label above the power connector.



CAUTION



Ground the equipment to prevent electrical shock and mutual interference.

Observe the following compass safe distances:

	Standard	Steering
Display unit for CSH-23	0.9 m	0.68 m
Display unit for CSH-24	1.70 m	1.30 m
Processor unit	1.70 m	1.05 m

TABLE OF CONTENTS

1. SYSTEM CONFIGURATION	1
2. EQUIPMENT LISTS	2
3. MOUNTING THE EQUIPMENT	
3.1 Mounting the Hull Unit and Receiver Unit	3
3.2 Mounting the Display Unit/Sub-display Unit	9
3.3 Mounting the Transmitter Unit.....	10
3.4 Mounting the Interface Unit.....	10
3.5 Mounting the FNZ Joint Box	10
3.6 Grounding the Equipment	11
4. WIRING	
4.1 Cable Configuration.....	12
4.2 How to Use the Crimping Tool, Pin Extractor	13
4.3 Location of Connectors	14
4.4 Fabricating Cables, Assembling Connectors	15
4.5 Connection of Transducer Cables.....	23
4.6 Connection of Interface Unit CS-120A	24
4.7 Connection of Sub-display Unit CSH-236/236F (Option)	29
4.8 Synchronizing Transmission with Other Sonars, Echo Sounders.....	30
4.9 Interlocking Operation with Other Sonar	32
5. CHANGING POWER SPECIFICATIONS	34
6. ADJUSTMENT AND CHECK	
6.1 Hull Unit Check.....	35
6.2 Heading Adjustment	36
6.3 DIP Switch Setting in the Display Unit	37
6.4 Setting and Adjustment of the Interface Unit CS-120A.....	38
7. PROCESSOR UNIT CSH-235/235F	42
SPARE PARTS/INSTALLATION MATERIALS/ACCESSORIES	A-1
OUTLINE DRAWINGS.....	D-1
INTERCONNECTON DIAGRAMS	S-1

1. SYSTEM CONFIGURATION

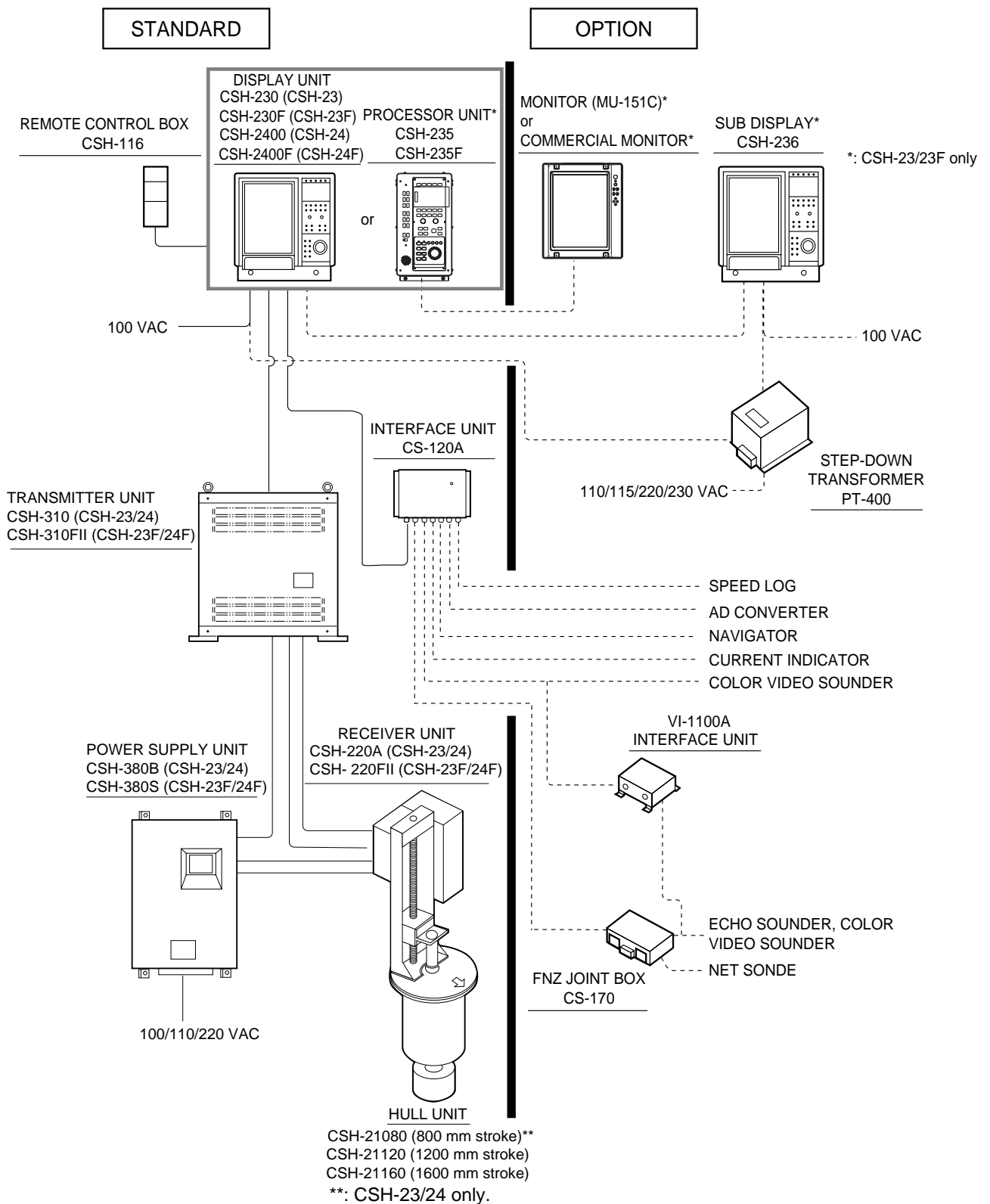

Figure 1-1 System configuration

2. EQUIPMENT LISTS

Standard Supply

Name	Type	Qty	Remarks	
Display Unit	CSH-230	1	CSH-23	
	CSH-230F		CSH-23F	
	CSH-2400		CSH-24	
	CSH-2400F		CSH-24F	
Processor Unit	CSH-235	1	CSH-23 Blackbox type	
	CSH-235F		CSH-23F Blackbox type	
Transmitter Unit	CSH-310	1	CSH-23/24	
	CSH-310FII		CSH-23F/24F	
Receiver Unit	CSH-220A	1	CSH-23/24	
	CSH-220FII		CSH-23F/24F	
Hull Unit	CSH-21080	1	stroke 800mm *	
	CSH-21120		stroke 1200mm	
	CSH-21160		stroke 1600mm	
Power Supply Unit	CSH-380B	1	CSH-23/24	
	CSH-380S		CSH-23F/24F	
Remote Control Box	CSH-116	1		
Interface Unit	CS-120A	1		
Installation Materials	CP10-02700	1 set	CP10-02710	CSH-23/23F
			6 pair cable	
	CP10-06400		CP10-06410	CSH-23/23F Blackbox type
			6 pair cable	
CP10-03400	CP10-03410	CSH-24/24F		
	6 pair cable			
Accessories	FP10-02400	1 set	FP10-01801	CSH-23/23F
			FP10-01201	
			FP10-01203	
	Nylon cover RAM card		CSH-23/23F Blackbox type	
	FP10-03000			FP10-01203
	FP10-01900		RAM card	CSH-24/24F
FP10-01901				
FP10-01201 FP10-01203				
Nylon cover Hood RAM card				
Spare Parts	SP10-01700	1 set	CSH-23/24	
	SP10-03300		CSH-23 Blackbox type	
	SP10-01800		CSH-23F/24F	
	SP10-03400		CSH-23F Blackbox type	

*:CSH-23/24 only

Optional Equipment

Name	Type	Mass (kg)	Code No.	Remarks	
FNZ Joint Box	CS-170	2	-		
Set-down Transformer	PT-400	22	-		
E/S Interface Unit	VI-1100A	2	-		
Sub-Display Unit	CSH-236	33	-	CSH-23/23F only	
	CSH-236F	33	-		
Hood	FP10-01801		006-027-830	For CSH-23/23F	
Hood	FP10-01901		000-690-855	For CSH-24/24F	
Filter	OP10-11		006-997-710	For CSH-23/23F	
Filter	FP10-02000		000-690-856	For CSH-24/24F	
Extension Cable Set (with inst. materials)	CSH-1600		000-068-165	For CSH-23/23F	
	CSH-1300		000-069-996	For CSH-24/24F	
37C Cable	10S1258		000-101-006	Specify length	
7C Cable	10S1259		000-101-007		
16P Cable	10S1260		000-101-008		
Handle Assembly	OP10-3		006-949-950		
Mounting Fixture	OP10-9		006-990-040		
Automatic Raise Modification Kit	CSH-1500		000-068-927		
ROM Option Kit A	OP10-15		006-998-620		
ROM Option Kit B	OP10-18		006-998-650		
Hull Unit	CSH-21081-1		-	Stroke 800mm, 24 kHz	Anti-slamming type
	CSH-21081-2		-	Stroke 800mm, 28 kHz	
	CSH-21121-1		-	Stroke 1200mm, 24 kHz	
	CSH-21121-2		-	Stroke 1200mm, 28 kHz	
	CSH-21161-1		-	Stroke 1600mm, 24 kHz	
	CSH-21161-2		-	Stroke 1600mm, 28 kHz	
Ant slamming Kit	OP10-21		-		

3. MOUNTING THE EQUIPMENT

3.1 Mounting the Hull Unit and Receiver Unit

Location of hull unit

Decide the location of the hull unit through consultation with the dockyard and shipowner. When deciding the location, the following points should be taken into account.

- Select an area where propeller noise, cruising noise, air bubbles and interference from turbulence are at a minimum. Generally, the point at $1/3$ to $1/2$ of the ship's length from the bow on or near the keel is optimum. On-the-keel installation is advantageous for minimizing oil consumption in comparison with off-the-keel. If the hull unit can not be installed on the keel, the center of the retraction tank should be within 600 mm of the keel to prevent a rolling effect.

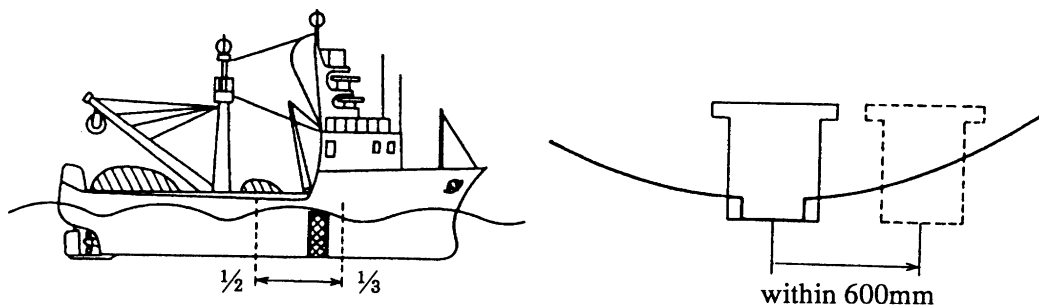

Figure 3-1 Hull unit mounting location

- Select a place where the hull bottom is flat and the draft is sufficiently deep. Normally, the transducer should protrude at least 500 mm beyond the keel to minimize the effect of air foam and bubbles.
- Select a place where interference from other equipment is minimal. The hull unit should be at least 2.5 m away from the transducers of other equipment.
- No obstacle should be in the fore direction since it causes a shadow zone and aerated water, resulting in poor sonar performance.
- The space shown in the figure on the next page is required around the hull unit for wiring and maintenance.
- If the ambient temperature of the unit is below 0°C , provide the sonar compartment with a heater to keep the temperature above 0°C .

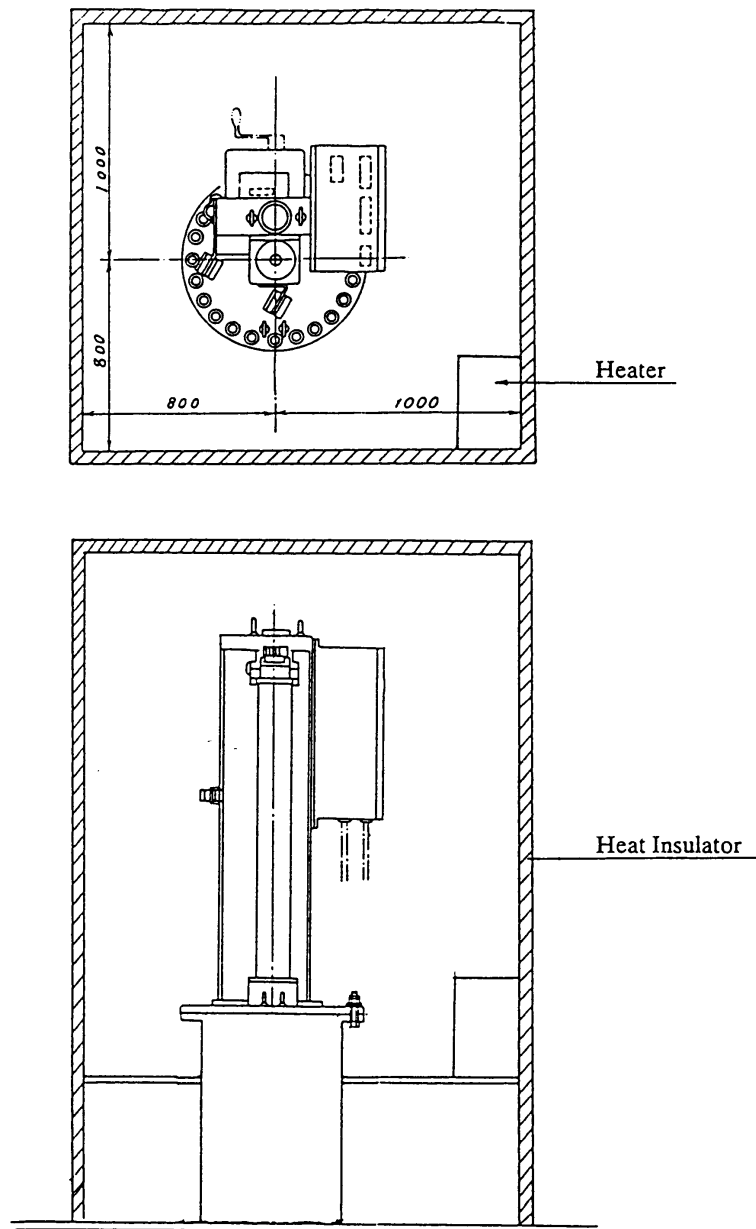

Figure 3-2 Maintenance space, example sonar compartment

Shortening the retraction tank

The retraction tank is 1300 mm in length when supplied. Shorten the tank as necessary so that the transducer is placed well below the keel when it is lowered. The following table provides guidelines for shortening the tank. Refer also to the retraction tank installation drawing at the back of this manual.



Installation Method				
XDCR Travel				
800 mm	Remove 297 thru 382 mm from the bottom.	Same as left	Remove 297 thru 382 mm from the bottom. Note that the length "D" must be less than 1003 mm.	Same as left
1200 mm	Remove 97 thru 382 mm from the bottom.	Same as left	Remove 97 thru 382 mm from the bottom. Note that the length "D" must be less than 1203 mm.	Same as left
1600 mm	Remove within 282 mm from the bottom.	Same as left	Remove within 282 mm from the bottom. Note that the length "D" must be less than 1703 mm.	Same as left

Figure 3-3 Guidelines for shortening the retraction tank

Note 1: In the 800 mm type hull unit, more than 297 mm must be removed from the bottom so that the transducer fully protrudes from the tank. If more than 382 mm is removed, the transducer cannot be retracted into the tank.

Note 2: In the 1200 mm type hull unit, the transducer will not fully protrude unless 97 mm is removed from the bottom, and cannot be fully retracted if more than 382 mm is removed.

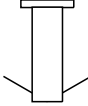
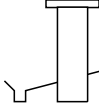
Note 3: In the 1600 mm type hull unit, the transducer cannot be fully retracted if more than 282 mm is removed.

Note 4: When 382 mm (282 mm for 1600 mm type) is removed and "D" is minimum, the effect of air foam is minimized because the transducer fully protrudes in water.

Remarks for installation of retraction tank

1. Make, if possible, the installation location a double bottom structure.
2. Install, if possible, the tank on the keel where the tank can be most firmly fixed.
3. Install the reinforcement ribs as near as possible to the top of the retraction tank, allowing space for tightening of bolts and nuts.

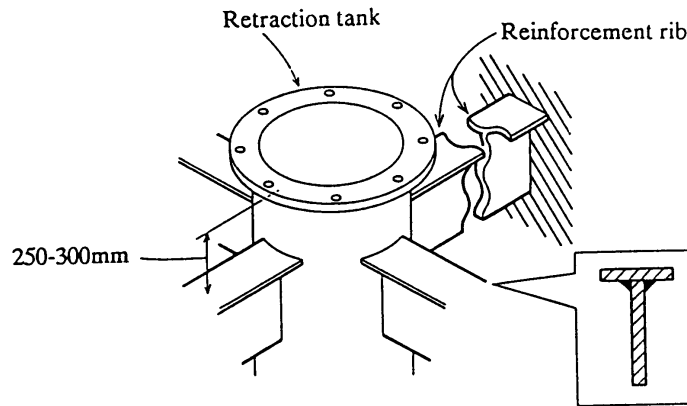

Figure 3-4 How to install reinforcement ribs

4. When an attachment flange is used, install reinforcement ribs to the attachment flange.

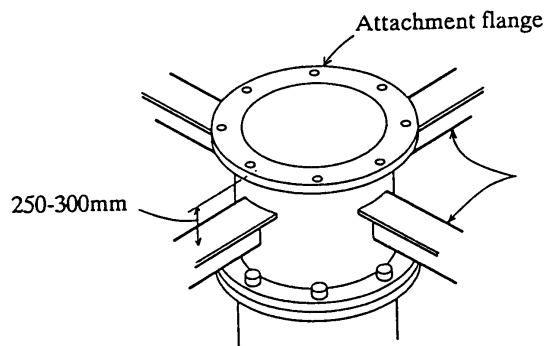

Figure 3-5 Installing reinforcement ribs to the attachment flange

5. Add a doubling plate at the location where the retraction tank is welded to the hull bottom. The size of the doubling plate is normally 1200 mm to 1300 mm in diameter so that it lies across two bottom frames.

Installing hull unit on retraction tank

After welding the retraction tank and allowing sufficient time for cooling, install the hull unit as follows:

1. Clean the hull unit flange, the O-ring and O-ring groove and coat them with a slight amount of grease. Place the O-ring in position on the tank flange.
2. Lay the gasket (1) on the top of the tank flange.
3. Orient the hull unit so that the bow mark (arrow) on its flange points toward the ship's bow. Note that heading adjustment in the display unit is required if the bow mark does not face the ship's bow.
4. For the 1200 mm transducer travel type, 11 of the 24 bolt holes on the hull unit flange have already been fitted with bolts. Insert the gasket (2) into the bolt holes of the tank flange to which these 11 bolts are fitted. Note that it is difficult to fit them after the hull unit has been placed on the tank.
5. Confirm that the O-ring and the gasket (1) are in position. Place the hull unit on the tank.
6. Coat every bolt, washer and nut with slight amount of grease to ease removal. Fit the insulation gasket (2) into the bolt holes of both the tank and hull unit flanges. Fasten the hull unit to the retraction tank with gasket (2), flat washers, spring washers and hex bolts. (Insulation gasket (2) and gasket (2) are used on the 1200 mm transducer travel type only.)
7. Reinforce the hull unit against vibration by extending stays to the ship's hull from the two eye bolts at the top of the hull unit, referring to figure at the top of the next page.

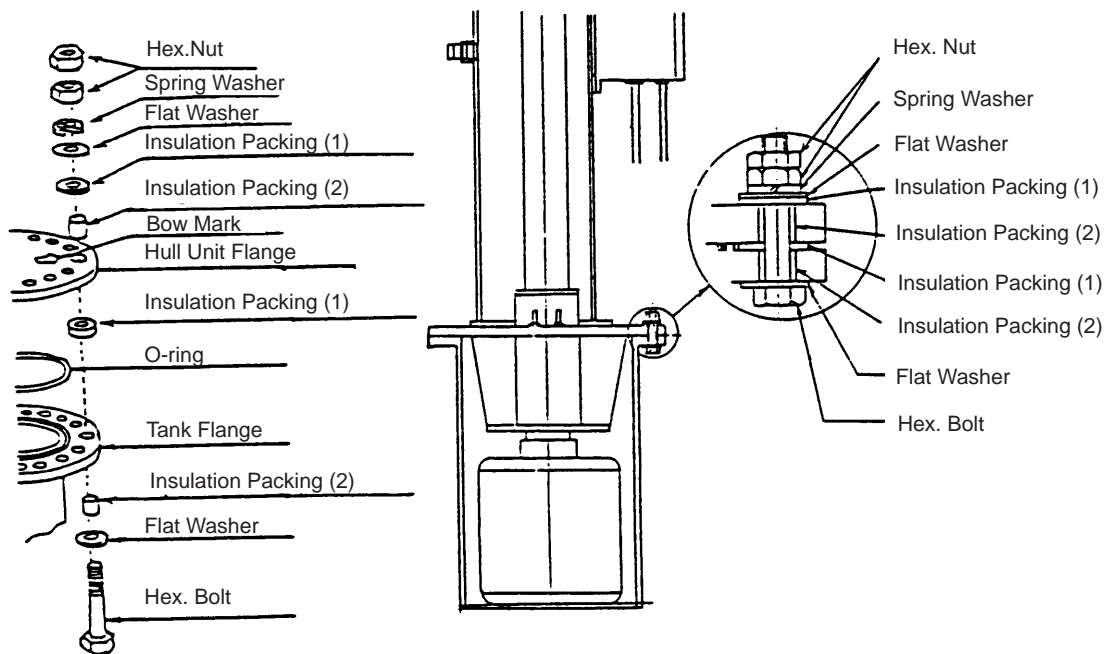

Figure 3-6 Installation of hull unit

Installing stays (anti-vibration measure)

Install stays from the top of the hull unit to the ship's hull. The stays should be angle iron with a size of 75 x 75 x 9 mm or more and at least two pieces should be used; one each to ship's bow and stern directions. Install if possible, two more stays in ship's transverse direction.

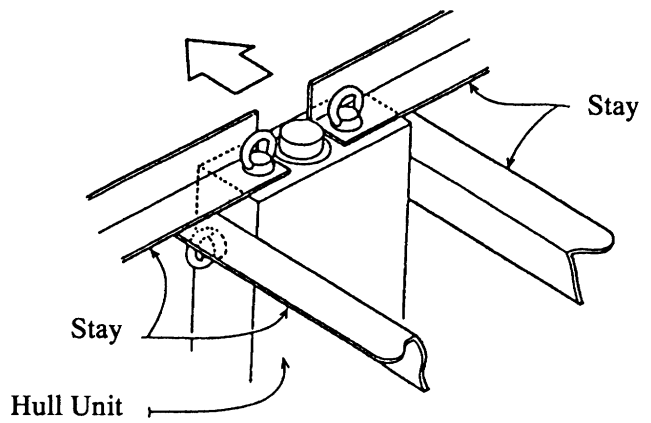

Figure 3-7 Proper installation of stays

Do not install the stays as shown below. Vibration-resistance effect is reduced since vibration is applied to the stays as rotation force. Install them horizontally.

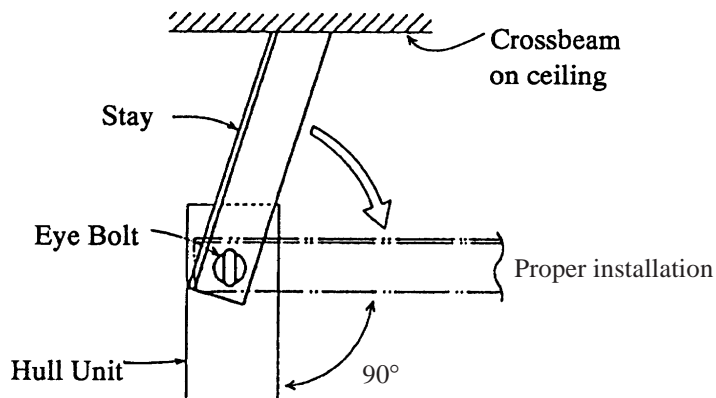

Figure 3-8 Proper and wrong installation of stay

Fastening receiver unit to hull unit

Fasten the receiver unit to the left side of the hull unit as shown at right.

A transducer cable protection cover has been fitted where the receiver unit is to be fastened to the hull unit. Remove it when mounting the receiver unit.

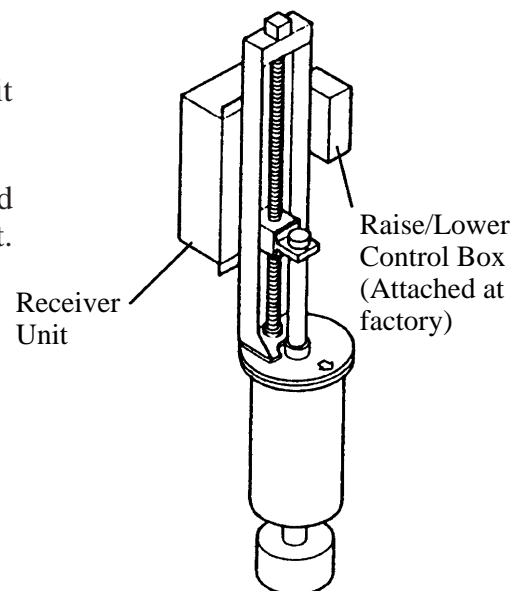
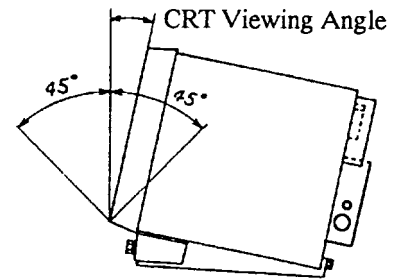

Figure 3-9 Mounting of receiver unit

3.2 Mounting the Display Unit/Sub-display Unit

The display unit/sub-display unit is designed for tabletop mounting. When selecting a mounting location consider the following conditions:

- Place where operating personnel are able to control the unit easily while observing the fishing ground or the area surrounding the vessel.
- Place at least 1 m away from a magnetic compass and components which have a magnet (radar magnetron, loudspeaker, high power transformer, etc.)
- Place not exposed to direct sunlight, water splashes or hot air.
- Place where maintenance and ventilation clearance shown in the outline drawings is ensured.
- Place where the CRT face is within $\pm 45^\circ$ from vertical.



Mounting the display unit/sub-display unit

1. Remove the mounting base by unscrewing the two bolts at the front bottom.
2. Fix the mounting base to the table with four M10 bolts, flat washers, spring washers and nuts. It is recommended that a rubber mat be placed under the mounting base to absorb vibration.
3. Fasten the unit to the mounting base with two bolts. When the space around the unit is limited, make wirings to the display unit first and then fasten the unit.

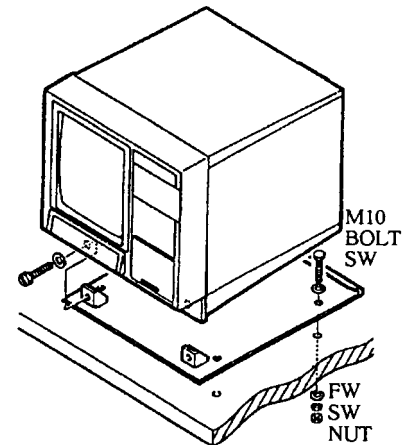

Note: For the CSH-24, remove eye bolts at the top of the display unit and set cosmetic screws (supplied with installation materials) to eye bolt holes.

Figure 3-10 Mounting the display unit, sub-display unit

3.3 Mounting the Transmitter Unit

The transmitter unit can be mounted with or without mounting legs. For use without mounting legs remove them and use inside mounting holes.

The transmitter unit should be reinforced against vibration by stays extending from the eyebolts on the top of the unit.

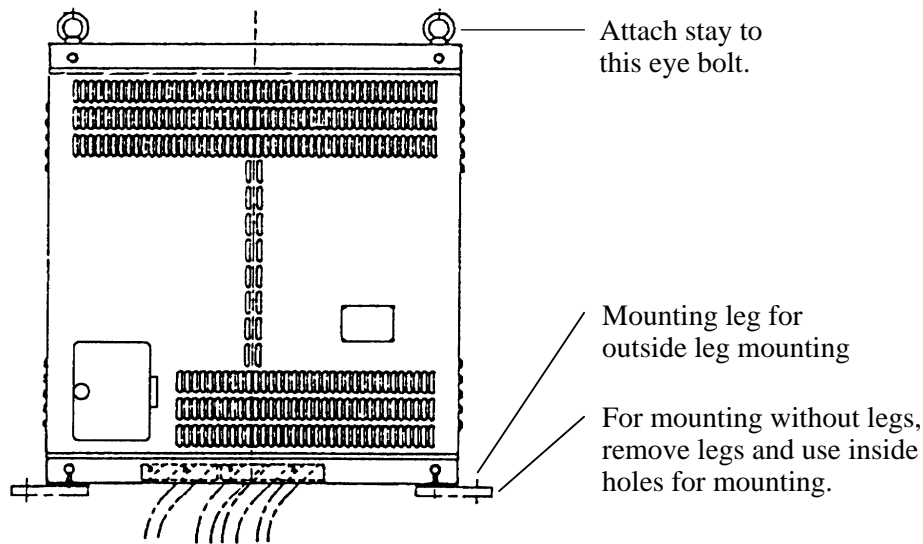

Figure 3-11 Transmitter unit

3.4 Mounting the Interface Unit

Since the interface unit connects with several navigation and fishing equipment, determine the installation site with the wirings to them taken into account. Furthermore, the unit incorporates a data selector and self-check switch, so select a place where they can be easily operated.

3.5 Mounting the FNZ Joint Box

The FNZ joint box is used for interchanging both TX trigger and sonde marker pulses from the echo sounder and the net sonde, therefore it should be installed as close as possible to the net-sonde indicator.

3.6 Grounding the Equipment

Ground all equipment with a suitable copper strap or ground wire. The location of the ground terminal of each unit is shown below.

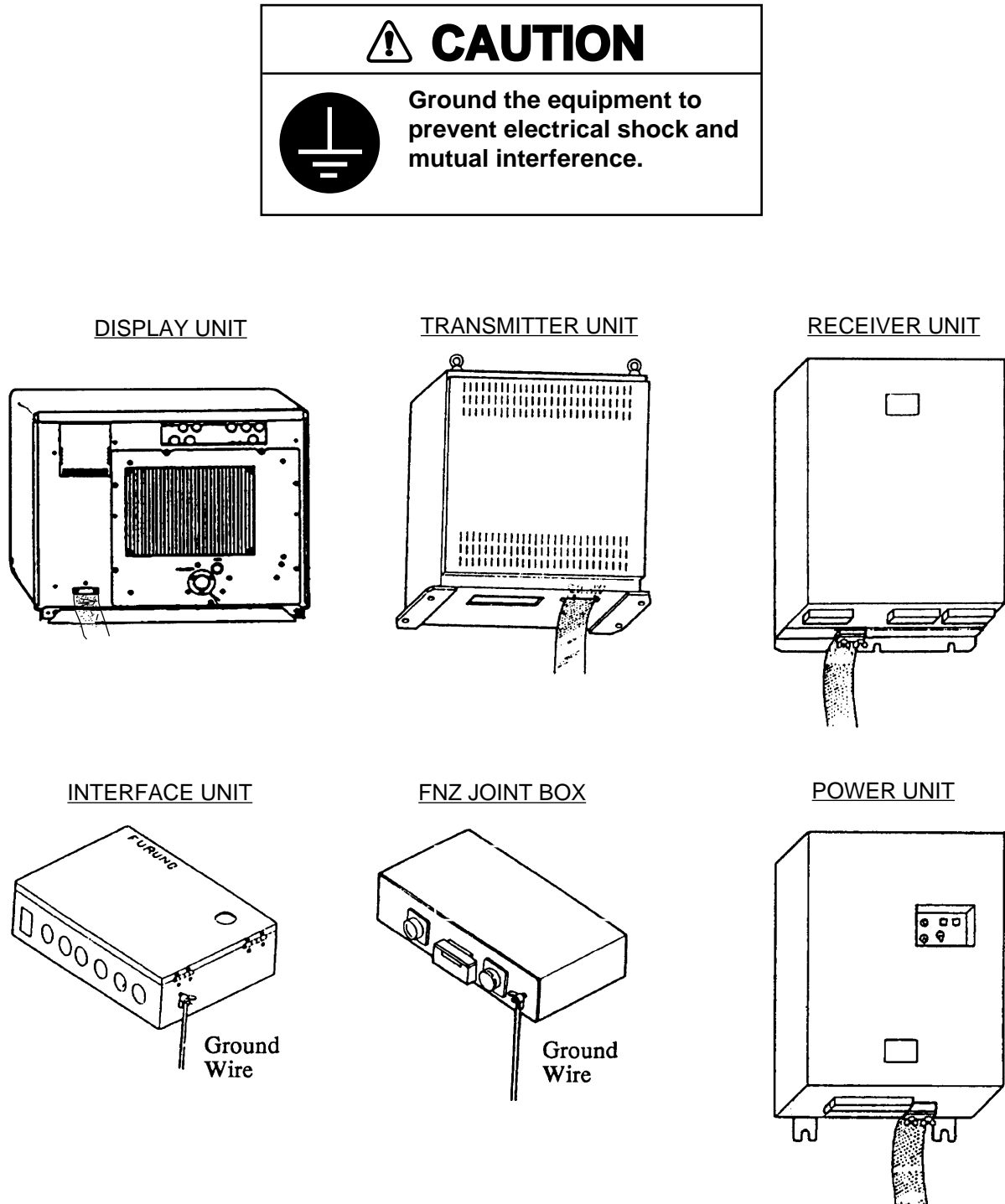

Figure 3-12 Location of ground terminals on equipment

4. WIRING

4.1 Cable Configuration

Wire Symbol	Name
○	Vinyl Sheath Wire
◌	Shielded Wire
◌	Twisted Pair Wire

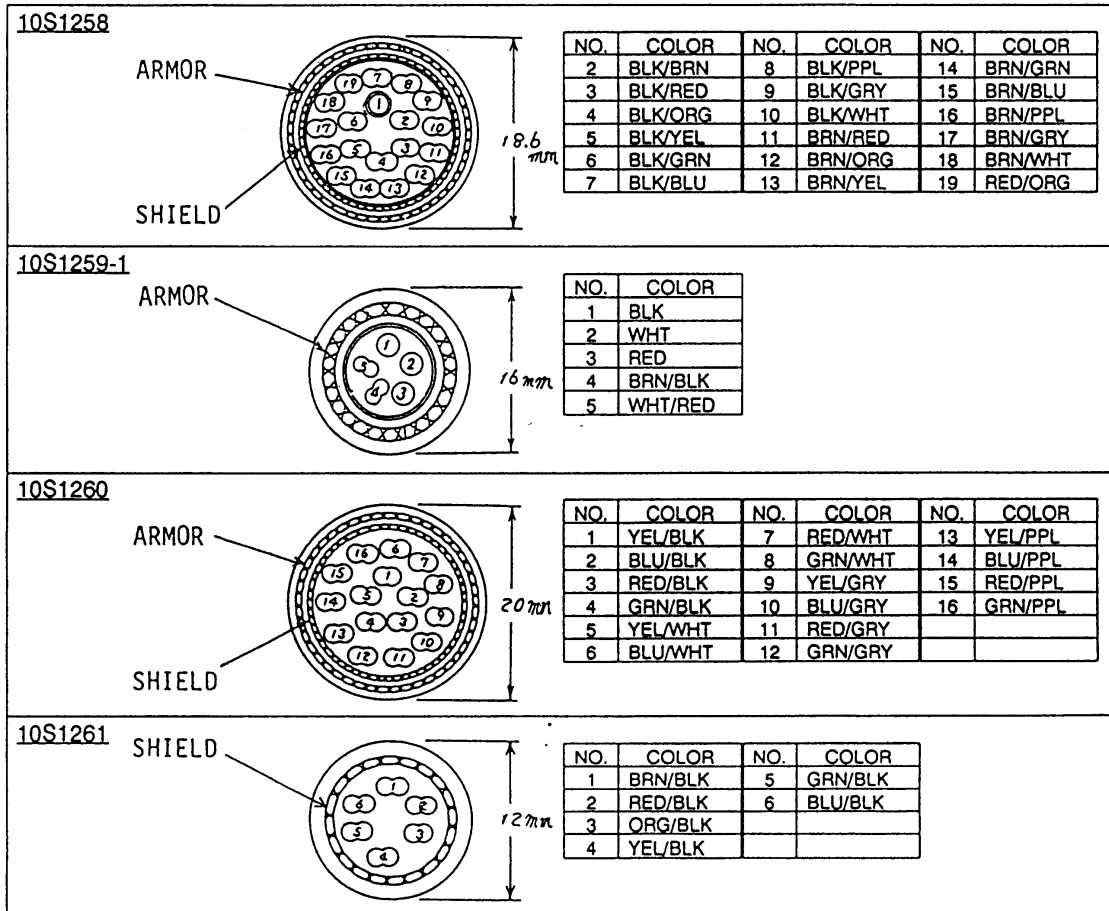

Figure 4-1 Cable configuration

4.2 How to Use the Crimping Tool, Pin Extractor

A special crimping tool is necessary for connection of wires to the contact pins of the 38P connector. The pin extractor removes the contact pin from the connector body. This paragraph describes how to crimp and extract the contact pin.

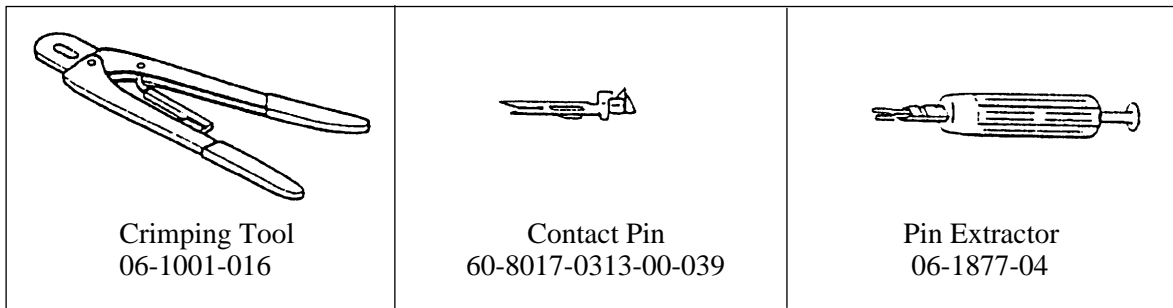

Figure 4-2a Crimping tool, contact pin, pin extractor

How to use the crimping tool

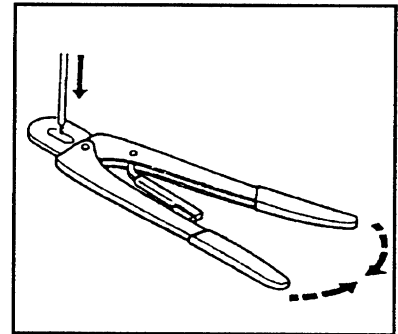

Figure 4-2b

How to use the pin extractor

If a contact pin is inserted into an incorrect hole on the connector body, remove it with the pin extractor.

1. Push the pin extractor into the pin hole from the side opposite to the pin inserting side.
2. Push in the head of the pin extractor. The retaining spring comes free and the contact pin can be removed.

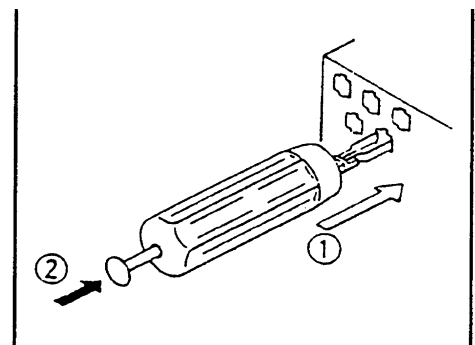

Figure 4-2c

4.3 Location of Connectors

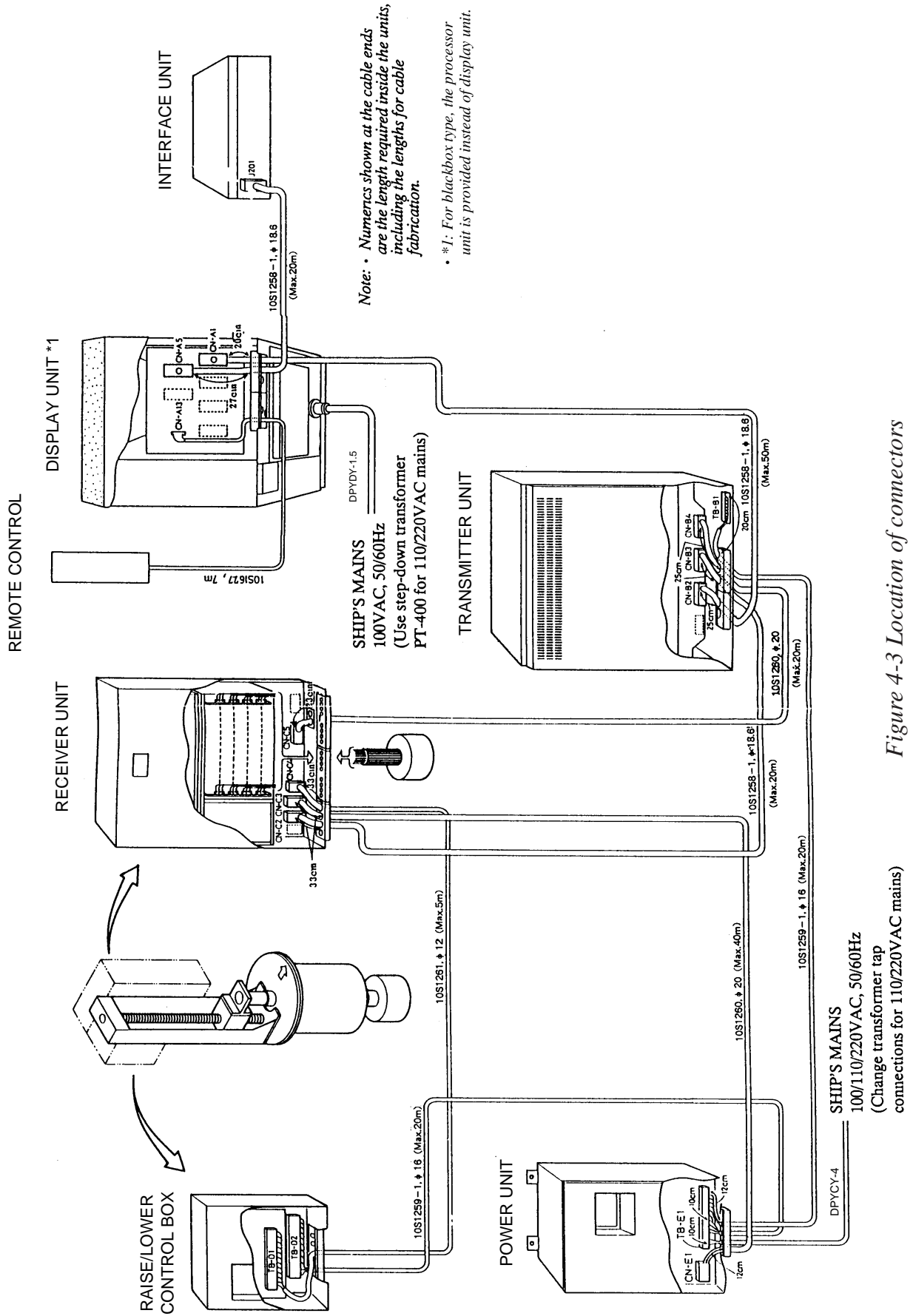

Figure 4-3 Location of connectors

4.4 Fabricating Cable, Assembling Connectors

Fabricating cable 00-8016-038-313-761HV

(CN-A1, CN-A5 and J201)

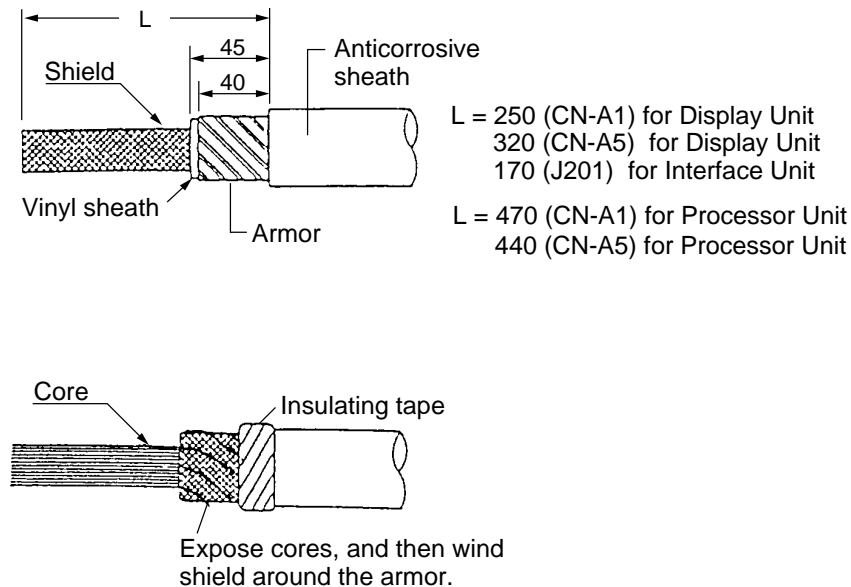

Figure 4-4 Fabrication cable 00-8016-038-313-761HV

Assembling the 38P connector

Shorten the unused wires appropriately and their ends with vinyl tape to prevent short circuit.

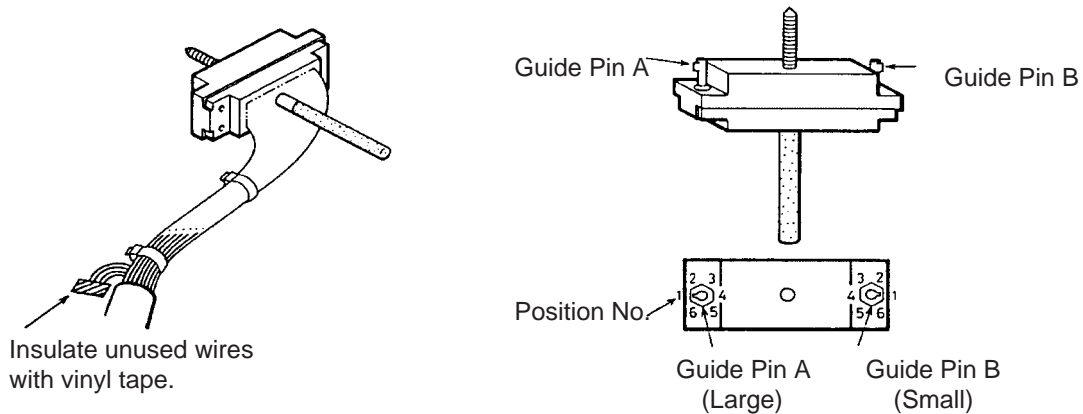

Figure 4-5 How to assemble the 38P connector

Positioning guide pins

Guide pins of the connector identify the mating receptacle. Position them as shown below.

Table 4-1 Guide pins and connectors CN-A1, CN-A5, J201

Connector	CN-A1	CN-A5	J201	Positioning Tool
Guide Pin				 Type: 10-910-0179-0
Guide Pin A (Large)	1	5	1	
Guide Pin B (Small)	1	1	1	

Clamping the cable

Clamp the cable where the shield is folded back onto the armor.

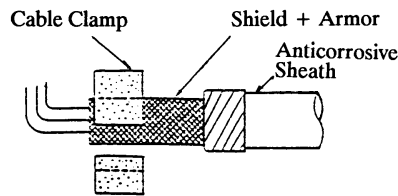

Figure 4-6 Clamping the cable

Assembling connector NSC-253P (CN-A15)

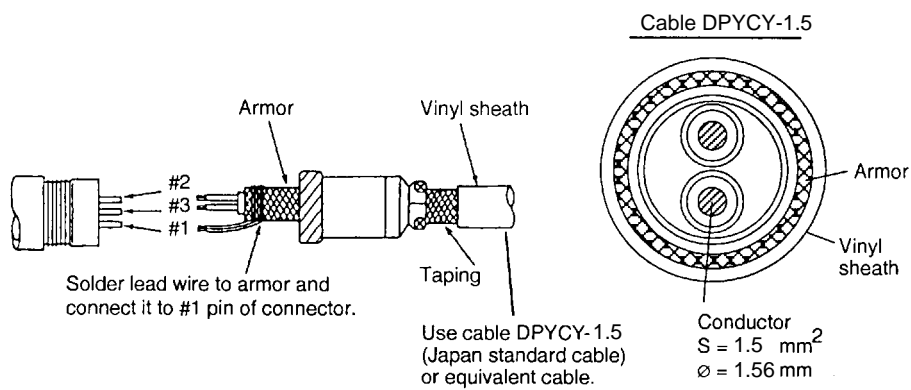

Figure 4-7 Assembling connector NSC-253P

Assembling BNC connector (CN-A7, CN-A8, CN-A9, CN-A10, CN-A11 and CN-A12)

1. Remove vinyl sheath of the cable by 15 mm.
2. Pass the cable through the nut, washer, gasket and clamp.
3. Unravel the shield and fold it back onto the clamp.
4. Remove the insulator, leaving 3 mm.
5. Trim the shield as shown in the drawing. Solder the center chip to the conductor of the cable.
6. Pass the cable through the housing and tighten the nut.

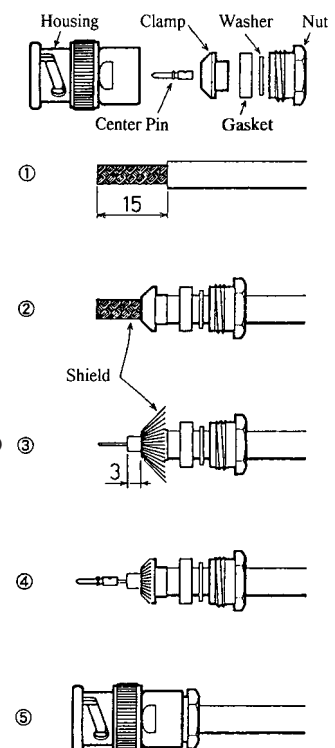

Figure 4-8 Assembling BNC connector

Fabricating cable 54-038-000-601/SC (CN-E1)

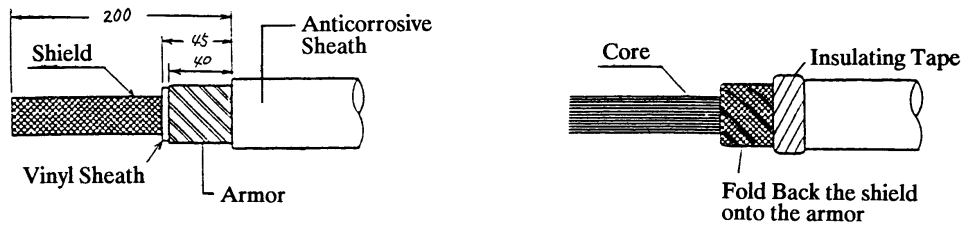

Figure 4-9 Fabricating cable 54-038-000-601/SC

Assembling 38P connector

1. Bundle the unused wires outside the connector case.
2. Fix the cover ①, taking heed of the cable outgoing direction.
3. Dress the wires and fix the cover ② and ③. Use a fragment of cable sheath to secure the wires at the connector clamp.
4. Shorten unused wires appropriately and treat their ends with vinyl tape to prevent short circuit.

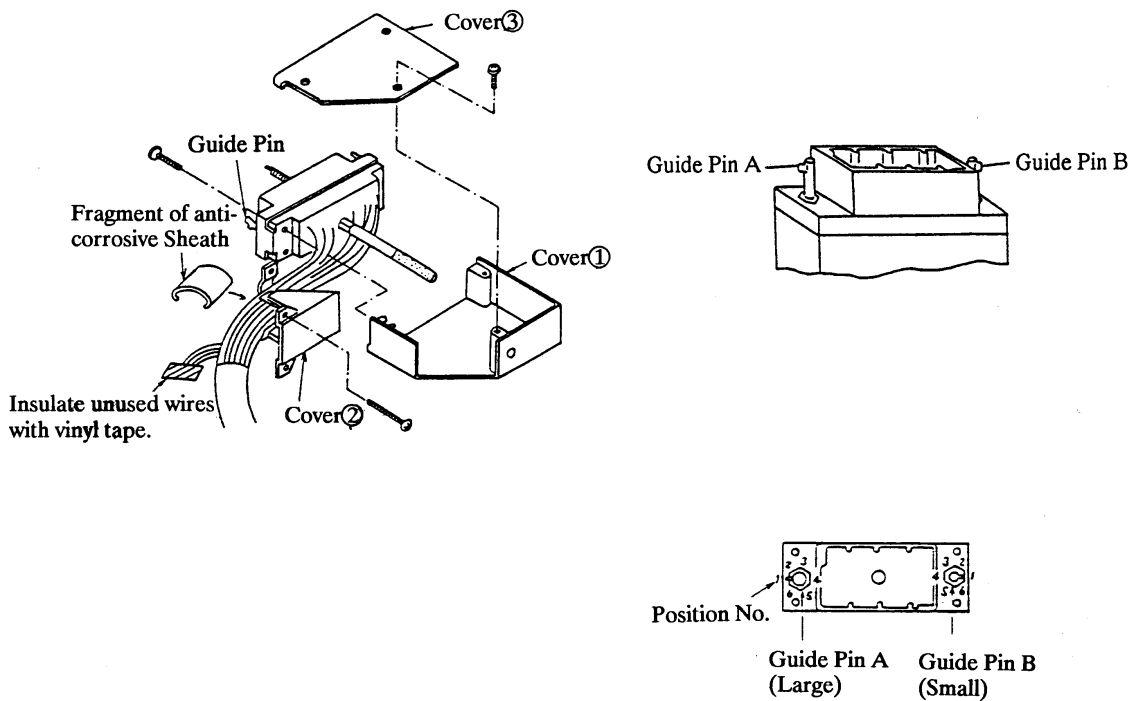
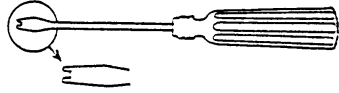

Figure 4-10 Assembling 38P connector

Positioning guide pins

Guide pins of the connector are used to identify the mating receptacle. Position them shown below.

Table 4-2 Guide pins and connector CN-E1

Connector	CN-E1	Positioning Tool
Guide Pin		
Guide Pin A (Large)	2	
Guide Pin B (Small)	1	

Type : 10-910-0179-0

Clamping the cable (side at power supply unit)

Clamp the cable as shown in below.

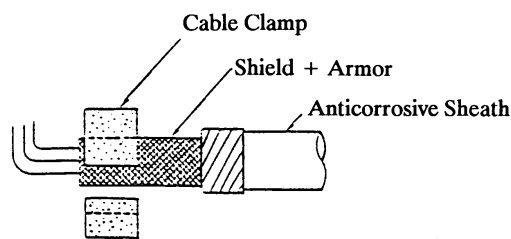

Figure 4-11

Fabricating cable 10S1259 (connected terminal board TB-E1)

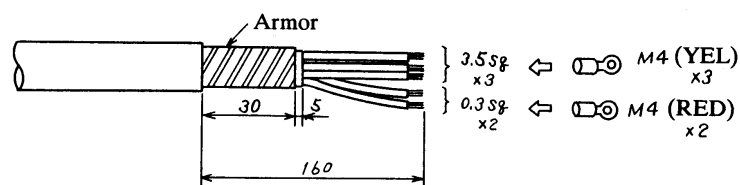

Figure 4-12 Fabricating cable 10S1259

Fabricating cable DPYCY-4 (connected to terminal board TB-E1)

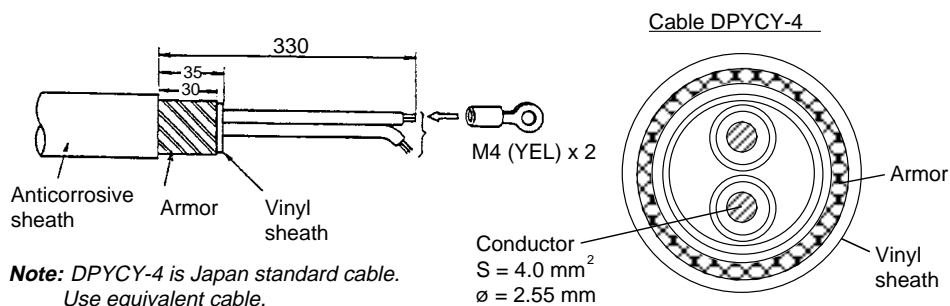

Figure 4-13 Fabricating cable DPYCY-4

Fabricating cable 54-038-000-601/SC (CN-B2, CN-B3, CN-B4)

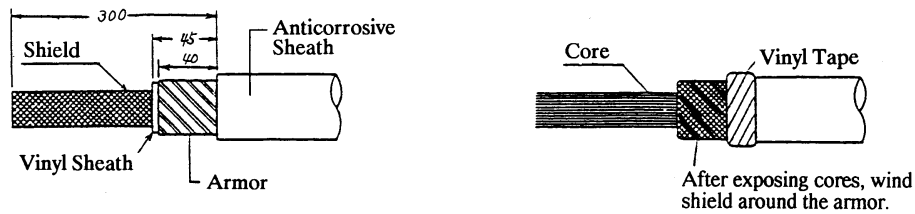

Figure 4-14 Fabricating cable 54-038-000-601/SC

Assembling 38P connector

1. Bundle the unused wires outside the connector case.
2. Fix the cover ①, taking heed of the cable outgoing direction.
3. Dress the wires and fix the cover ② and ③. Use a fragment of cable sheath to secure the wires at the connector clamp.
4. Shorten unused wires appropriately and treat their ends with vinyl tape to prevent short circuit.

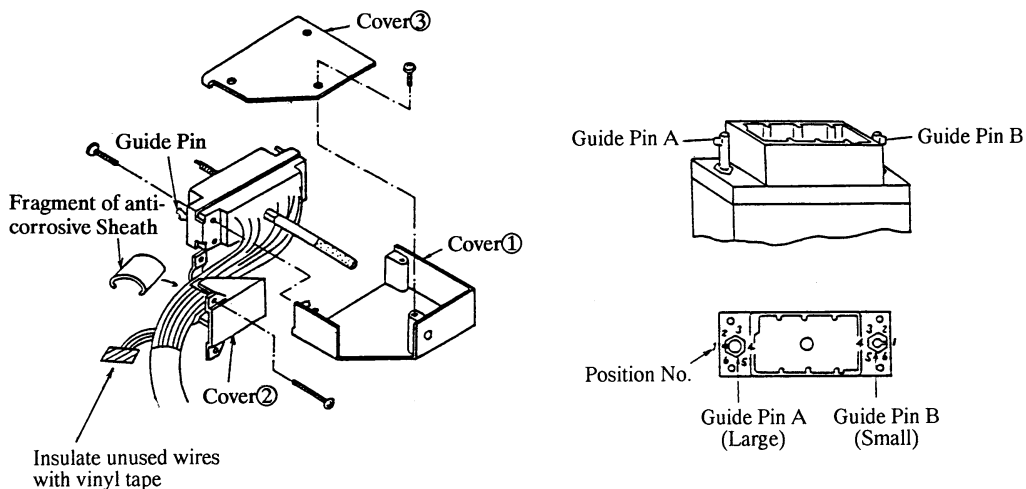
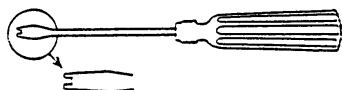

Figure 4-15 Assembling 38P connector

Positioning guide pins

Guide pins of the connector identify the mating receptacle. Position them as shown below.

Table 4-3 guide pins and connectors CN-B2, CN-B3, CN-B4

Connector	CN- B2	CN- B3	CN- B4	Positioning Tool
Guide Pin A (Large)	1	1	3	 Type : 10- 910- 0179- 0
Guide Pin B (Small)	1	1	1	

Clamping the cable

Secure the cable with the cable clamp.

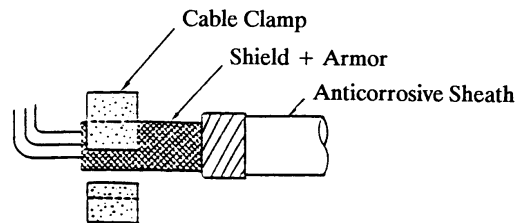

Figure 4-16 Clamping the cable

Fabricating cable 10S1259 (connected to terminal board TB-B1)

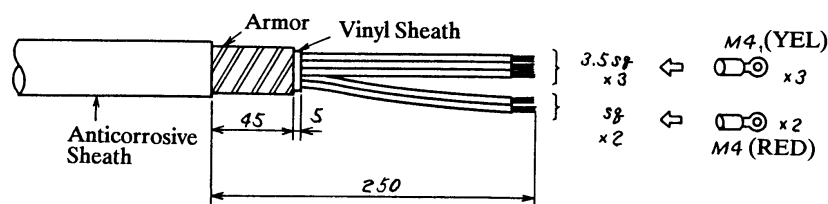

Figure 4-17 Fabricating cable 10S1259

Fabricating cable 54-038-000-601/SC (CN-C2, CN-C3 and CN-C5), 00-8016-020-313-703V (CN-C4)

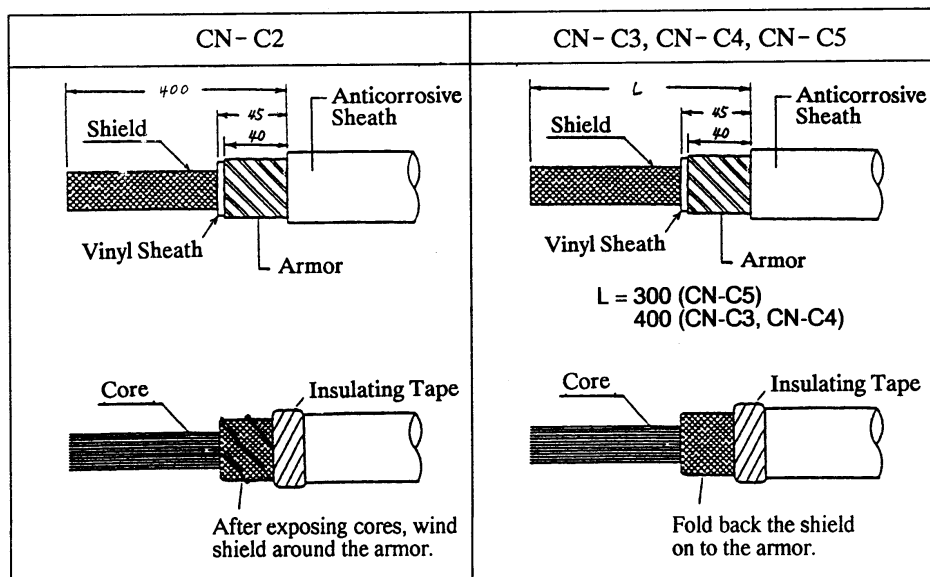

Figure 4-18 Fabricating cable 54-038-000-601/SC, 00-8016-020-000-703V

Assembling 38P connector

1. Bundle the unused wires outside the connector case.
2. Fix the cover ①, taking heed of the cable outgoing direction.
3. Dress the wires and fix the cover ② and ③. Use a fragment of cable sheath to secure the wires at the connector clamp.
4. Shorten unused wires appropriately and treat their ends with vinyl tape to prevent short circuit.

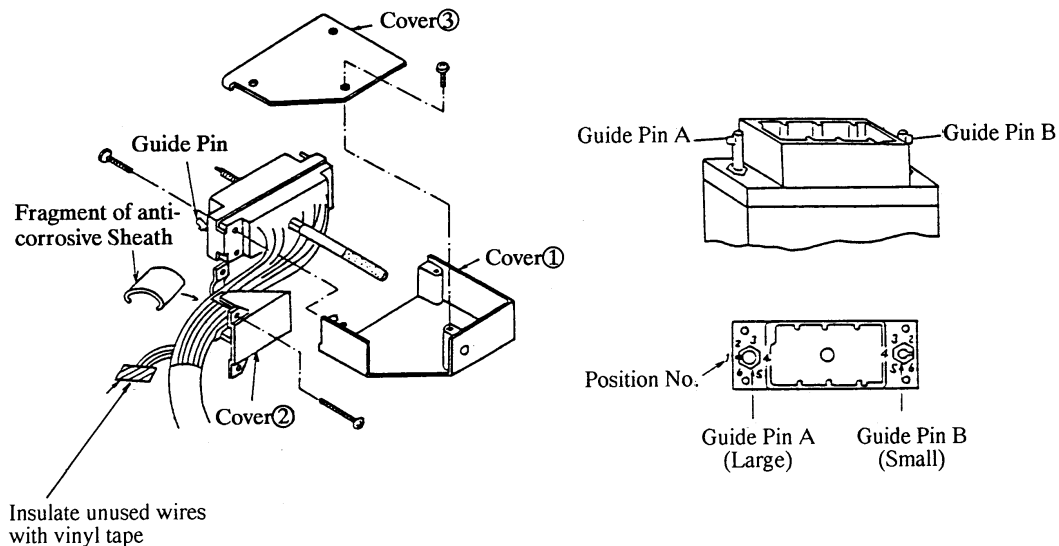
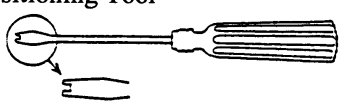

Figure 4-19 Assembling 38P connector

Positioning guide pins

Guide pins of the connector identify the mating receptacle. Position them as below.

Table 4-4 Guide pins and connectors CN-C2, CN-C3, CN-C4, CN-C5

Connector \ Guide Pin	CN - C2	CN - C3	CN - C4	CN - C5	Positioning Tool  Type : 10-910-0179-0
Guide Pin A (Large)	1	2	1	3	
Guide Pin B (Small)	1	1	1	1	

Clamping the cable

Clamp the anticorrosive sheath of the cable.

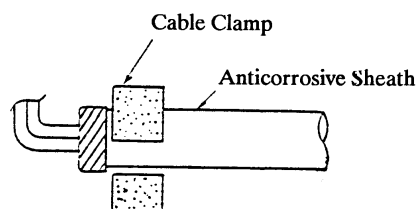

Figure 4-20 Clamping the cable

Fabricating cable connected to terminal board TB-D1 in Raise/Lower Control Box

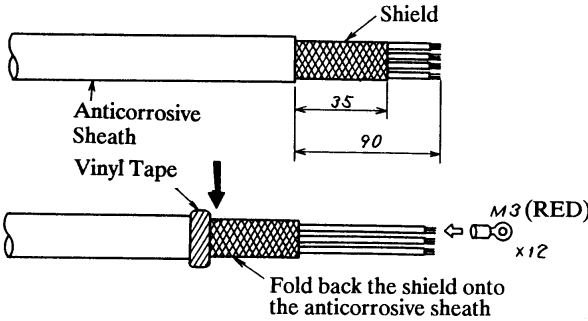

Figure 4-21 Fabricating cable connected to terminal board TB-D1 in Raise/Lower Control Box

Fabricating cable 10S1259 (connected to terminal board TB-D2 in Raise/Lower Control Box)

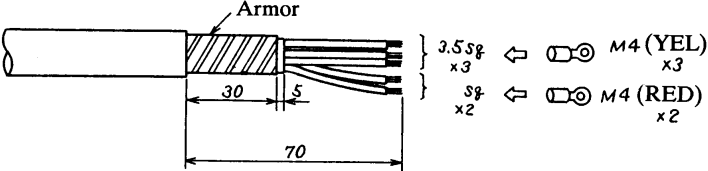

Figure 4-22 Fabricating cable 10S1259

4.5 Connection of Transducer Cables

The transducer cables are supplied with connectors. Plug them into the receptacles in the receiver unit, referring to the stickers on the cables.

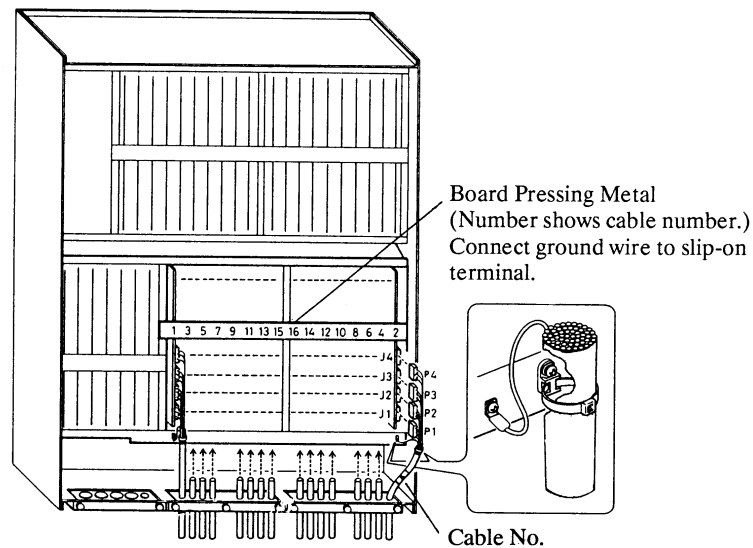
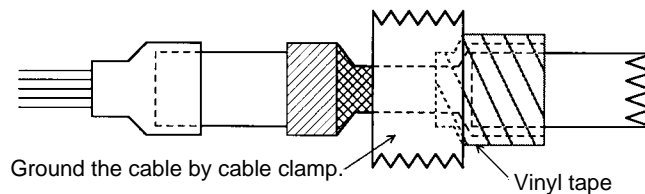
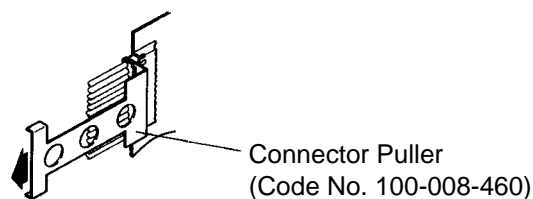

Figure 4-23 Receiver unit, rear view

Lead the cable into the receiver unit and clamp it as follows.



1. Use the connector puller (supplied) to unplug connectors.



2. When one or some of the lead wires are severed near a connector, cut off all lead wires connected to the connector and solder the "XH connector assembly" (type 10-145 (13P), supplied as spare parts).

4.6 Connection of Interface Unit CS-120A

With connection of navigator, the Interface Unit CS-120A and electronic fishing equipment, the function of the CSH-23/24 series is expanded to include true motion presentation, target lock, echo sounder picture, FNZ marker presentation and digital indication of position, water temperature and depth. This chapter provides the information for interfacing the CSH-23/24 series with external equipment.

Connections for true motion and target lock

Heading (digital) and speed (200 pulses/nm) data are required to provide the true motion and target lock functions. Both data are fed to the display unit via Interface Unit CS-120A.

Basically, there are three methods to feed the data:

- Heading data is fed to J205 from A/D Converter AD-100 and the speed pulse data to J206 from the speed log.
- Both heading and speed data are fed to J207 or J204 from the CIF line of the CI-30/50/60.
- NMEA signal is fed to J208 (NMEA port) or J207 (CI/NMEA port).

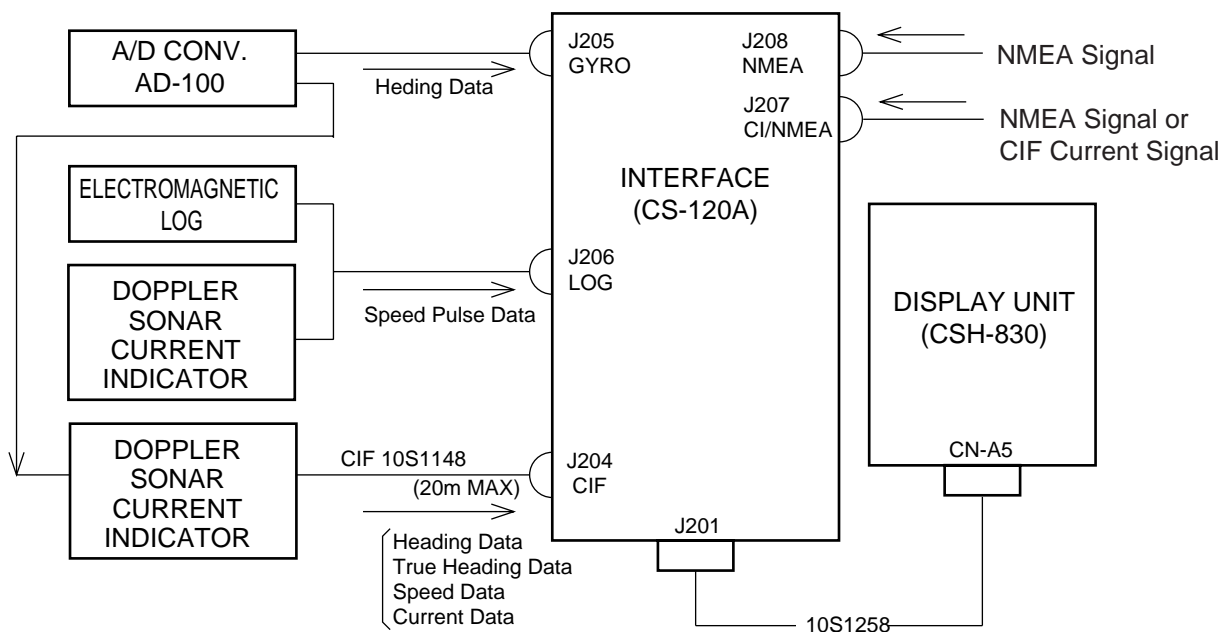

Figure 4-24 Connection of external equipment to Interface Unit CS-120A

Note 1: AD-100 outputs two types of data. 200 ms interval is available.

Note 2: 200 pulses/mile ship's speed data can be taken from a doppler sonar current indicator.

There are six combinations of CIF/NMEA data input.

Combination	NMEA port J208	CIF port J204	CI/NMEA port J207
1	NMEA data	—	NMEA data
2	NMEA data	—	CIF current data
3	—	CIF data	CIF current data
4	NMEA data	—	—
5	—	CIF data	—
6	—	—	NMEA data

Note: NMEA port and CIF port are not fed a data at the same time. Either CIF current data or NMEA data can be fed to CI/NMEA port.

Speed pulse signal

Do not feed Speed pulse data when speed data is fed from NMEA or CIF port and the current indicator is chosen as own ship's navigation data (refer to page 38). If they are fed at the same time, the moving distance data will be doubled.

Receivable Data

- Receivable Sentences from NMEA port
 - Depth Data : DBT、DPT
 - Temperature Data : MTW
 - Position fixing Data : GGA、RMC、GLL、RMA
 - Speed Data : VTG
 - Heading Data : VTG、HDT
 - Current Data : VHW、VDR、CUR
 - Time Data : ZDA
- Receivable NMEA Sentences from CI/NMEA port
 - Same data as NMEA data is received. NMEA port has priority.
- Receivable CIF data from CIF port
 - 11 : Time Data
 - 21 : Dead reckoning Position
 - 24 : Loran C fixing Position
 - 28 : GPS fixing Position
 - 41 : Speed and Heading Data for Dead reckoning
 - 48 : Speed and Heading Data from GPS fixing data
 - 56 : Current indicator Data for Display
 - 66 : Current indicator Heading, Speed, True Course Data
 - 76 : Current indicator ID Number, Depth, Current Direction, Current Speed
 - 57 : Depth Indicator Depth, Depth Information
 - 58 : Temperature Indicator Temperature, Temperature Information
- Receivable CIF data from CI/NMEA port
 - 56 : Current indicator Data for Display
 - 66 : Current indicator Heading, Speed, True Course Data
 - 76 : Current indicator ID Number, Depth, Current Direction, Current Speed

Connections for ES picture and FNZ markers

To provide echo sounder picture and FNZ markers, connect echo sounder to J203 and net sonde to J202. The signals applied to J202 and J203 are

J202: Net sonde signal and trigger signal (keying pulse of echo sounder). A white line signal from an echo sounder may be additionally applied as described on the next page if the digital depth data is not available on J204.

J203: Echo signal and keying pulse from an echo sounder.

Connection 1: Displaying echo sounder picture

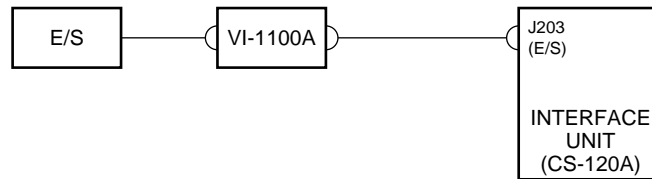

Connection 2: Displaying echo sounder picture and FNZ markers by one echo sounder

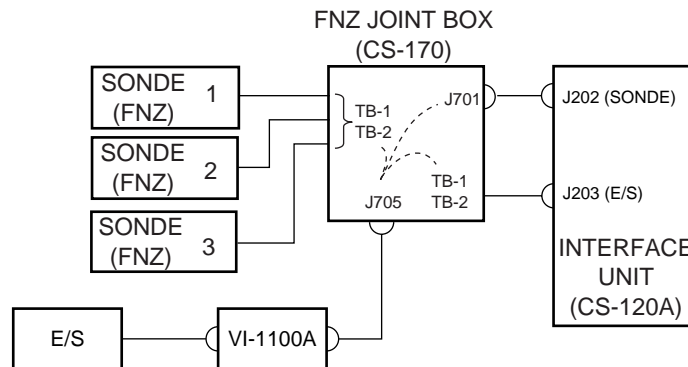

This method is used when the net sonde is installed and both echo sounder and net sonde signals are taken from the same echo sounder. The net sonde signal is applied to both J202 and J203.

Connection 3: Displaying echo sounder picture and FNZ markers by separate echo sounders

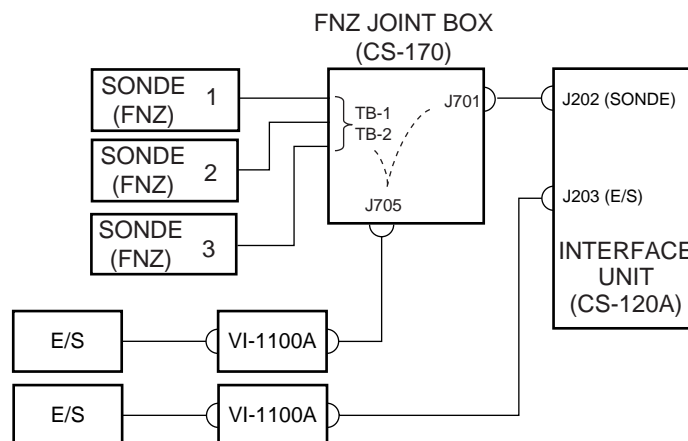

Connections for digital indication of position, water temperature and depth

The data for these readouts are taken from the equipment shown in the table below and input to J208 or J204. Input to J208 if the data is NMEA format, or to J204 if the data is CIF format.

Data	Data Source
Position	Loran C navigator, GPS navigator
Water Temperature	Temperature Indicator T-2000/TI-20, nav equipment or color video sounder connected to temperature sensor
Depth	Color video sounder

Note: When a sounder which has digital depth data output is not available, the white line signal of a paper recording echo sounder can be used to provide digital depth readout. Connect the echo sounder as shown below or as shown in connection 2 or 3 on previous pages and operate the echo sounder front panel controls so that the white line is effected on the seabed contour.

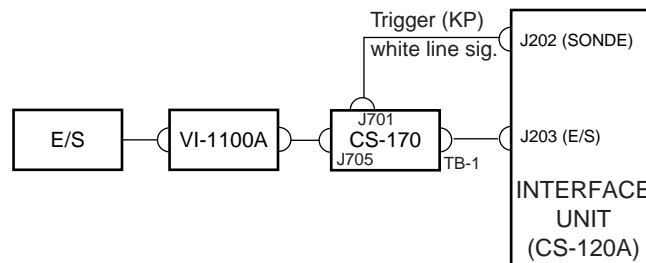

Wiring

Connect referring to the Interconnection Diagram at the back of this manual.

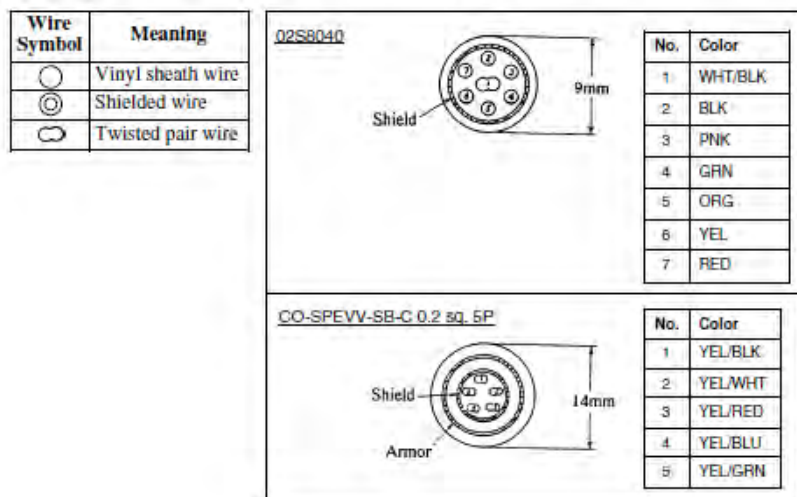

Fabrication, assembling 10P and 7P connectors

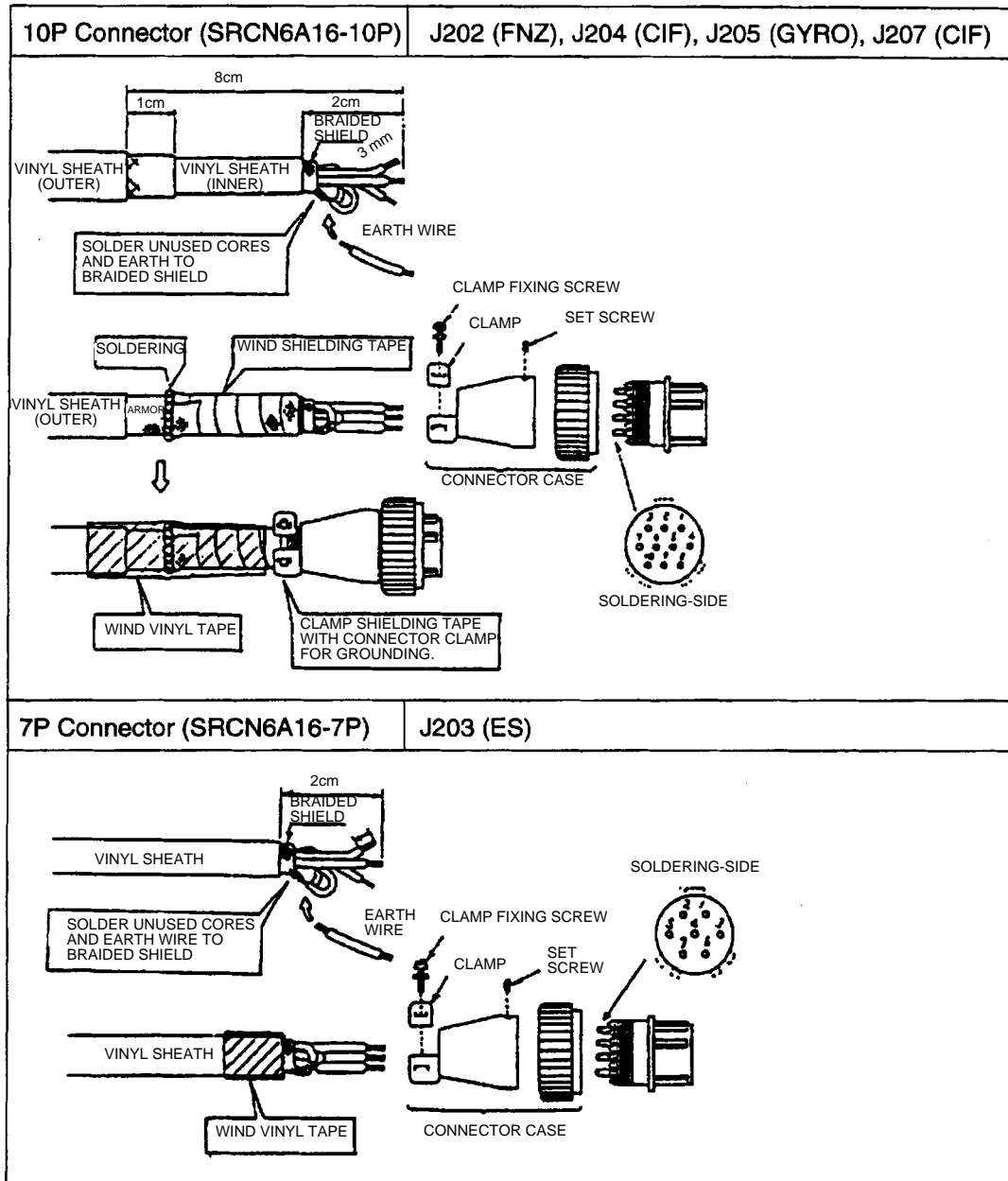

Figure 4-30 Fabrication of 10P, 7P connectors

4.7 Connection of Sub-display Unit CSH-236/236F (Option)

The Sub-Display Unit CSH-236/236F is the same as the Display Unit CSH-230/230F in terms of outline dimension and control panel layout. It controls the sonar at a place remote from the display unit while observing picture on the screen. One sub-display unit can be connected to three display units.

Note: The Sub-Display Unit can be connected to CSH-23/23F only.

Connections

Refer to the interconnection diagram at the end of this manual.

Note: One sub-display unit can be connected to three sonars, but different models cannot be connected.

DIP switch setting

Set DIP switch S1 on the RDCB Board (10P6724) in the sub-display unit as follows:

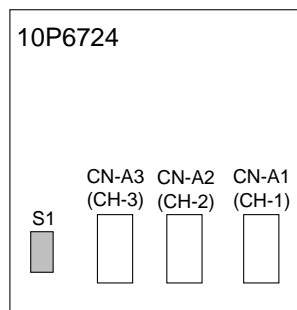

SW No.	Used for	Function
1 2 3	Display unit on CH-1 Display unit on CH-2 Display unit on CH-3	ON: Turning on sub-display unit automatically turns on display unit. (Don't set OFF because the system doesn't work.)
4 5 6	Display unit on CH-1 Display unit on CH-2 Display unit on CH-3	ON: Turning on display unit automatically turns on sub-display unit. OFF: Sub-display unit is not turned on when display unit is turned on.
7	Not used.	Used in remote display unit. Set to ON in sub-display unit.
8	Not used.	

Figure 4-31 DIP switch setting on RDCB board in the sub-display unit

Note: To have both the display unit and sub-display unit turned on when either unit is turned on, turn on SW #1 and #4.

4.8 Synchronizing Transmission with Other Sonars, Echo Sounders

To synchronize the transmission of the CSH-23/24 series sonars to that of other sonars or echo sounders, wire units as follows.

Connections

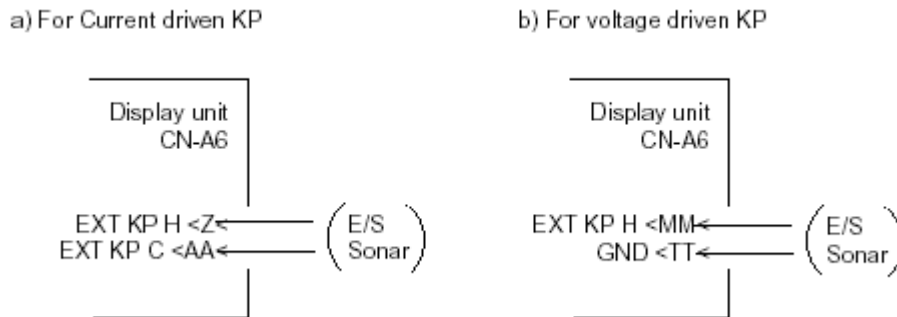
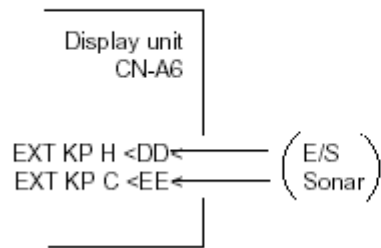

Figure 4-33 Connections for synchronizing transmission with echo sounder having current driven KP, voltage driven KP

Note: To output KP to other sonar or echo sounder, wire units as follows.

a) Current driven KP output



b) Voltage driven KP output

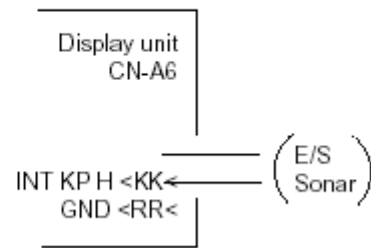

Figure 4-34 Connections for outputting KP to other sonar or echo sounder

Menu setting

Set polarity of the KP on the INIT SET/TEST menu. Set transmission cycle to 0 on data setting window. Refer to the operator's manual for operation on the menu.

4.9 Interlocking Operation with Other Sonar

Functions (range, tilt, fish mark, etc.) and remote control may be mutually interlocked with those on other sonars (CSH-23/24/73/83/84). For example, if the range is interlocked, changing the range in one sonar automatically sets the other sonar to the same range. The functions to be interlocked can be selected on the SYSTEM menu. See the operator's manual for further details.

Connections for interlocking functions

Two sonars

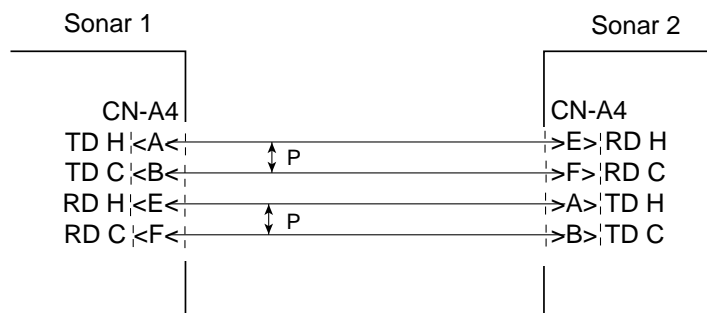

Figure 4-35 connections for interlocking function of two sonars

Three sonars

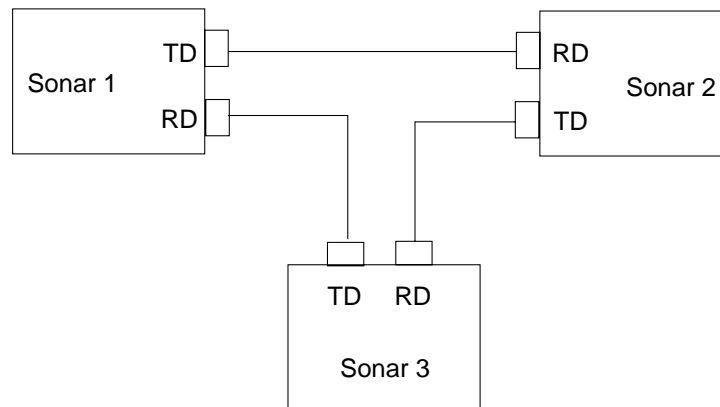

Figure 4-36 Connections for interlocking functions of three sonars

DIP switch setting

Set ID code on DIP switch #1 to #3 on main panel. Any code is acceptable, provided that it is not the same as that set on the other sonar.

Connections for interlocking remote control

To control multiple display units by one remote control box, wire units as follows.

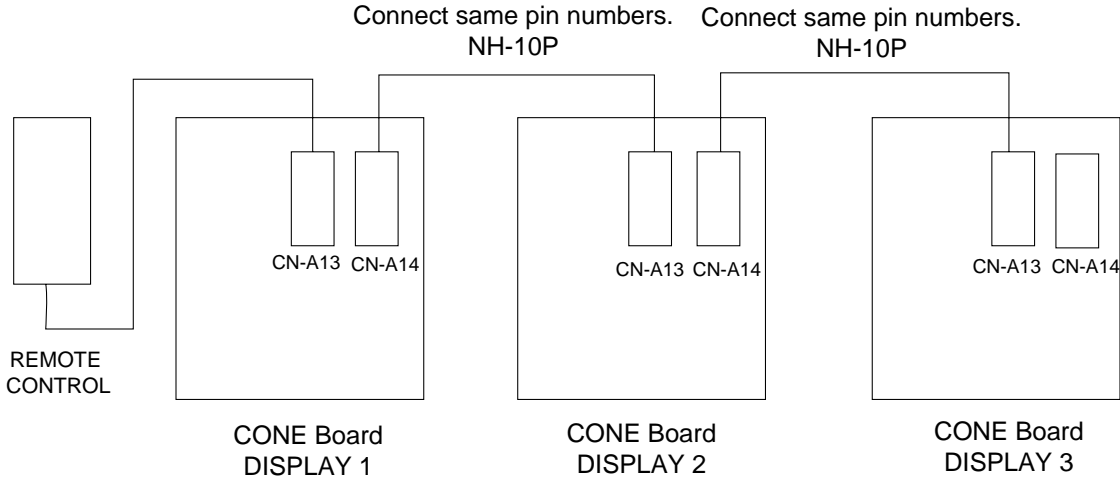
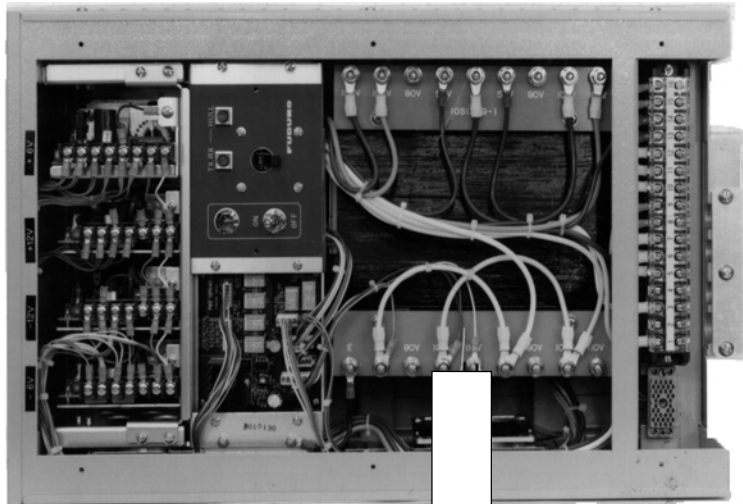

Figure 4-37 Connections for interlocking remote control

5. CHANGING POWER SPECIFICATIONS

The display unit is set at the factory for connection to a ship's mains of 110 VAC or 220 VAC. To power it by 100 VAC or 220 VAC, use step-down transformer PT-400, change the transformer taps on the power supply unit as below and connect the ship's mains directly.



The power supply unit has been set for 100 VAC when delivered.

F Photo No.2017

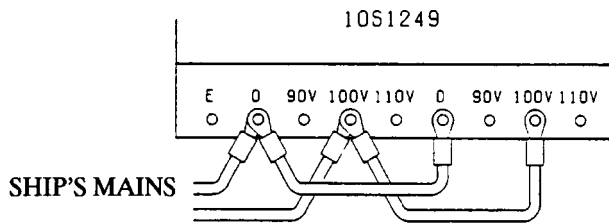

For 100VAC Ship's Mains

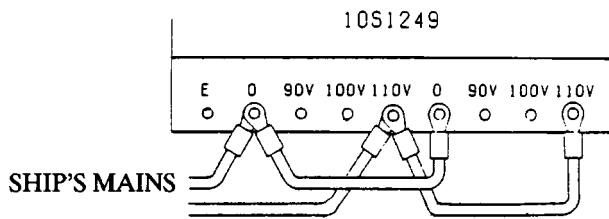

For 110VAC Ship's Mains

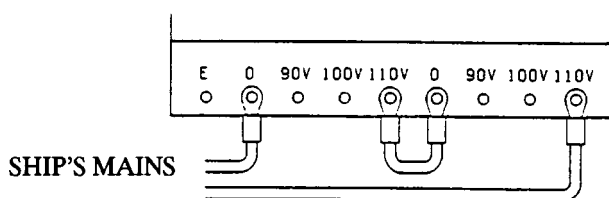

For 220VAC Ship's Mains

Figure 5-1 Tap connections on the transformer in the power unit

6. ADJUSTMENT AND CHECK

6.1 Hull Unit Check

1. Press the ON switch to turn on the equipment. Confirm that the lamps above the ON and ↑ switches light.
2. Confirm that the 5V and UP lamps on the raise/lower control box are lit.
3. Remove the cover of the raise/lower control box and check the following voltages:

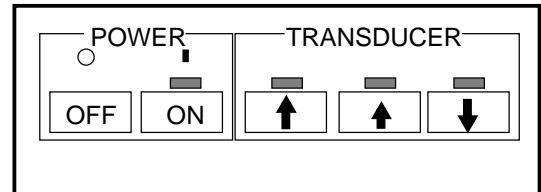

Figure 6-1 Display unit front panel

Terminal	Terminal No.	Voltage
TB-D1	⑦ - ⑧	+12 V
TB-D2	① - ②	180 VAC
	② - ③	180 VAC
	① - ③	360 VAC

4. In the raise/lower control box, turn the TEST/NORMAL switch to TEST. Press the ↓ switch to confirm that the transducer lowers. Also, while the transducer is being lowered, check that the MD LED lights when the MD L. SW kicks. Note that the MD L. SW does not stop the transducer when the TEST/NORMAL switch is in the TEST position.
5. Press and release the ↓ switch. Confirm that the transducer stops at the moment the switch is released.
6. Press the ↓ switch again. Confirm that the transducer stops at the moment the lower limit switch kicks.
7. Confirm that the ↑ switch operates in a similar manner.
8. Check that LEDs on the panel of the raise/lower control box light as follows:
 - 1) UP, MD and DN LEDs light when corresponding limit switch kicks.
 - 2) UP and DOWN LEDs light while UP and DOWN switches are pressed and extinguish when switches are released.
9. Set the TEST/NORMAL switch to NORMAL.
10. At the display unit, press the ↓ (mid position) switch. Confirm that the lamp above the switch blinks while the transducer is being lowered, a short beep sounds when the mid limit switch kicks, and the lamp lights when the transducer is fully lowered.
11. Press the ↓ switch. Confirm that the lamp above the switch blinks while the transducer is being lowered, a short beep sounds when the mid limit switch kicks, and the lamp lights when the transducer is fully lowered.

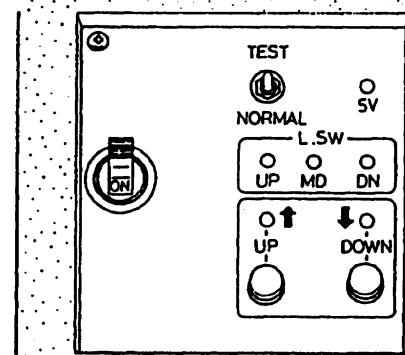

Figure 6-2 Raise/Lower control box

12. Press the **↑** switch. Confirm that the lamp above the switch blinks while the transducer is being raised, a short beep sounds when the mid limit switch kicks, and the lamp lights when the transducer is fully raised.
13. Press the OFF switch. Confirm that the transducer is completely retracted and then the power is turned off.
14. With the transducer lowered, confirm that the transducer is raised when **↑** or OFF is pressed.

6.2 Heading Adjustment

When the BOW mark on the flange of the hull unit cannot be directed toward ship's bow adjust the heading so an echo which is dead ahead appears dead ahead on the display.

1. Locate a target in the bow direction (buoy, for example) and display it on a near range. If the target appears at 12 o'clock the heading alignment is correct. If it does not go to step 2.

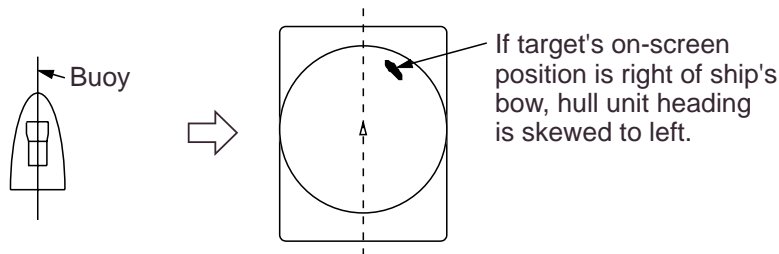

Figure 6-3 Heading adjustment

2. Turn on the power while pressing and holding down the MENU key. The INIT SET/TEST menu appears.

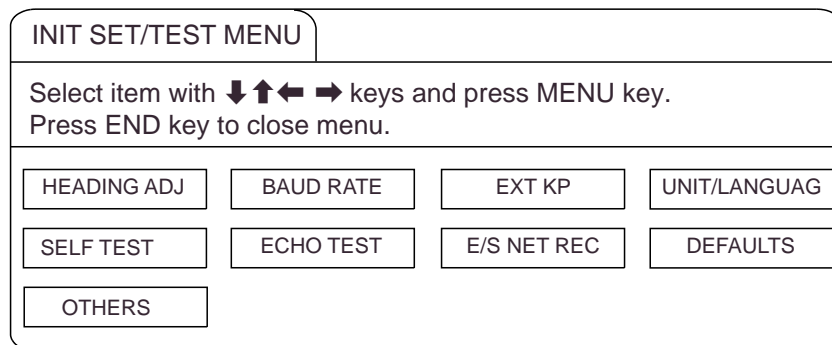

Figure 6-4 INIT SET/TEST menu

3. Select HEADING ADJ.

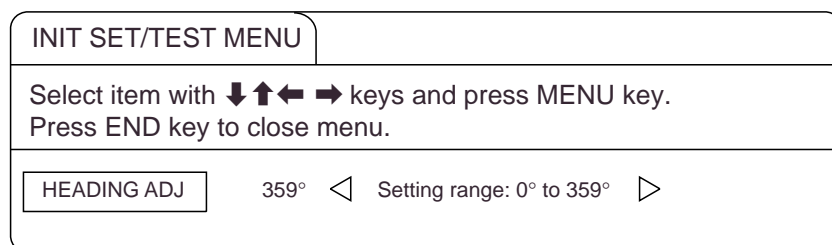

Figure 6-5 HEADING ADJ menu

4. Enter heading correction with ← or → referring to the table below for guidance.

Target Location	Correction Setting
Target displayed 30° to port	Set to 30°
Target displayed 30° to starboard	Set to 330°

6.3 DIP Switch Setting in the Display Unit

Set the DIP switch on the display unit, referring to the table shown below.

1. Remove six screws from the main panel.
2. Unplug four connectors.
3. Set the DIP switch.
4. Reassemble display unit.

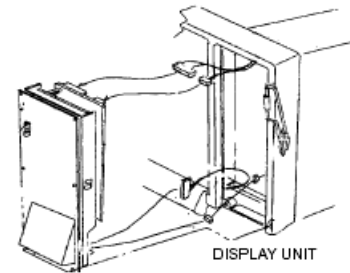

Figure 6-6 How to remove main panel from display unit

DSW Board (10P6722F)

Item	SW No.	Setting				
ID Code for Interlock Function	1	Set ID code for interlock operation of CSH-21/71/81/82/53/23/73/83 sonar. Any code is acceptable unless it is used in other interlocked sonars.				
	2					
	3					
Unit Code	4	OFF	ON	ON	OFF	ON
	5	OFF	OFF	ON	OFF	ON
	6	OFF	OFF	OFF	ON	ON
	Unit	CSH-58 (28 kHz) CSH-53 (28 kHz)	CSH-53 (55 kHz)	CSH-23/24	CSH-73/83/84	CSH-23F/23FL/24F/24FL
EEPROM Check	7	ON	Check OFF	OFF	Check ON	
Stand Alone	8	For factory use. Set to ON always.				

PND Board (10switchP6714)

Item	SW No.	Setting	
Display unit setting	3*	OFF	For 21" CRT display unit (CSH-24/24F/24FL/84)
		ON	For 15" CRT display unit (CSH-23F/23FL/24F/24FL)

*: Set to OFF for the Processor unit.

6.4 Setting and Adjustment of the Interface Unit CS-120A

DIP switch setting

Navigation data and fishing data input from external equipment can be turned on or off by DIP switches DP-1 and DP-2 on CPU II board 10P6871 in the Interface Unit CS-120A.

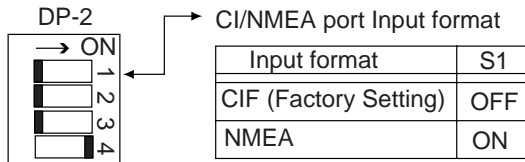

Standard Setting

Changed the register R78 (47Ω) to 470Ω on pcb 10P0047 when NMEA is selected.
 -NMEA: 470Ω
 -CIF: 47Ω

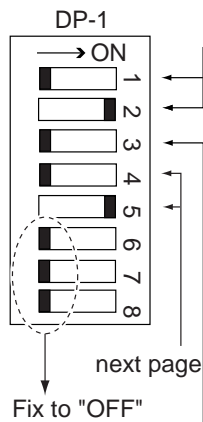
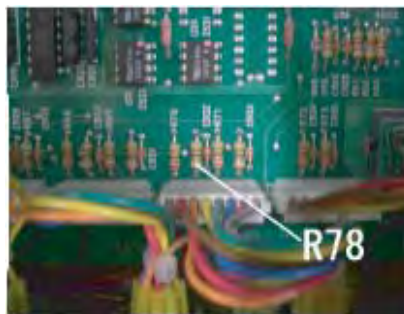
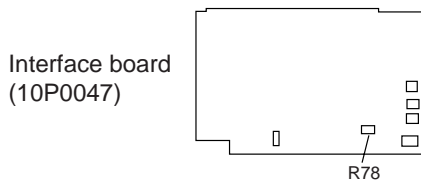

Own ship's navigation data (Gyrocompass, Speed log or Current indicator etc.)

Input Device	S1	S2
Gyrocompass, Sppeed log	OFF	OFF
GPS or DR *1	ON	OFF
Current indicator	OFF	ON
Gyrocompass, GPS *2	ON	ON

Select navigation device which feeds navigation data for drawing ship's track by S1 and S2.

*1: GPS ship's speed/heading data from NMEA or CIF line, or dead reckoning speed/heading data are used. Take care that heading data may have error if the speed is lower than 0.2 kts.
 *2: Courseline is plotted by using CIF or NMEA format speed data and Gyrocompass data. Speed log is set by using GPS or Current Indicator.

Latitude/Longitude

Input Device	S3
Loran C	OFF
GPS or DR *	ON

Own ship's position data is selected with S3.

*: Data from GPS or DR is used (GPS has priority).

next page
 Fix to "OFF"

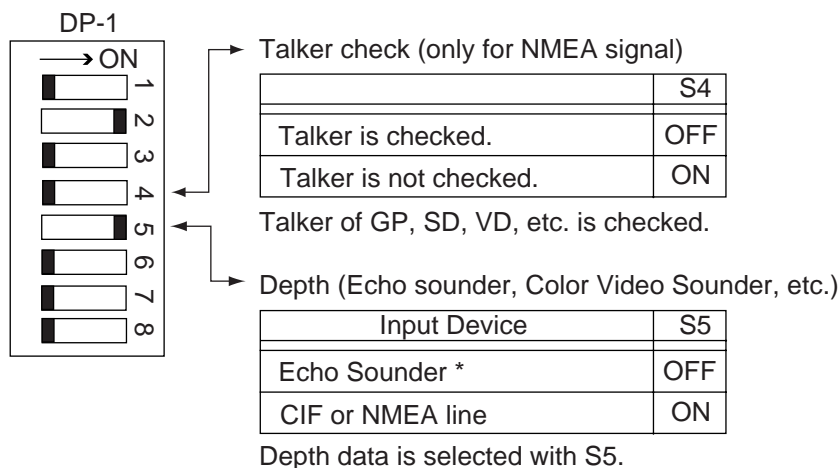

*: Use this position for white line pulse when the depth data is taken from an echo sounder. However late model FURUNO echo sounders do not output white line pulse. Normally set to ON.

Interface unit (10P0047) adjustment

If the E/S picture on the screen does not have the desired coloration, perform the adjustment as follows with the preset potentiometers on the I/O board in the interface unit.

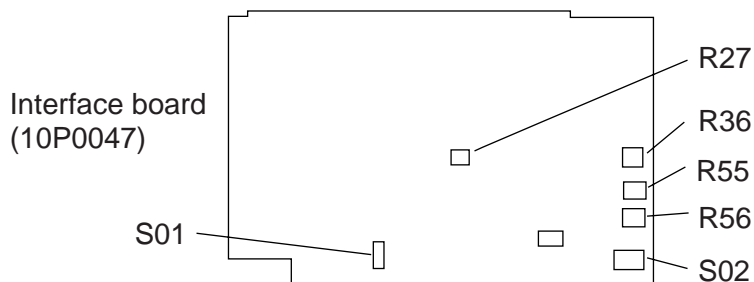

Setting for DIP switch

S01:  ON
OFF

The FNZ marker is plotted on the echo sounder picture with this switch turned on when FNZ marker signal is fed to External Interface. Factory setting is the "ON" position.

S02:  AC DC

Selects the signal mode (AC or DC) according to the combined echo sounder connected. Factory setting is the "AC" position.

Adjustment of signal level (R36, R56)

1. Set the MODE switch to E/S.
2. Turn the potentiometer R36 to suppress a noise, and the potentiometer R56 so that the color gradation of the E/S picture on the screen appears similar to the intensity gradation of the combined E/S echogram.

Adjustment of white line inhibit time (R27)

In case digital depth data is not combined with the CS-120A, the white line signal from the echo sounder is used for depth information. Potentiometer R27 cancels the white line pulse for about 10 ms after transmission to avoid false depth indication caused by unwanted noise in short ranges. Readjustment of potentiometer R27 is not required as long as CSH-23/24 series indicates the correct depth. If does not, however turn R27 to the right.

Adjustment of white line output level (R55)

Improper setting of potentiometer R55 causes the seabed line to be painted in deep blue due to the white line pulse. Adjust it so that the seabed line is painted in same color as seabed.

Priority for data

The priority between ports, the category of data or formats is as follows. "1" has the highest priority.

Basic priority

1. NMEA data > CIF data
2. NMEA data: NMEA port data > CI/NMEA port data
3. CIF data: CI/NMEA port data > CIF port data

Heading priority

1. Heading data from GYRO port
2. GP-HDT from NMEA port (GP-HDT: HDT sentence with Talker GP)
3. GP-HDT from CI/NMEA port
4. VD-VHW from NMEA port
5. VD-VHW from CI/NMEA port
6. VD-CUR from NMEA port
7. VD-CUR from CI/NMEA
8. CIF signal <66> from CI/NMEA port
9. CIF signal <66> from CIF port

GPS fixing position priority

Latitude and Longitude are set to GPS/DR with S3 on the DIP switch DP-1.

1. GP-GGA from NMEA port
2. GP-GGA from CI/NMEA port
3. GP-RMC from NMEA port
4. GP-RMC from CI/NMEA port
5. GP-GLL from NMEA port
6. GP-GLL from CI/NMEA port
7. <28> from CIF port

LC fixing position priority

Latitude and Longitude are set to LC with S3 on the DIP switch DP-1.

1. LC-RMA from NMEA
2. LC-RMA from CI/NMEA
3. <24> from CIF port

Depth priority

Depth is set to CIF/NMEA with S5 on the DIP switch DP-1.

1. SD-DPT from NMEA port
2. SD-DPT from CI/NMEA port
3. SD-DBT from NMEA port
4. SD-DBT from CI/NMEA port
5. <57> from CIF port

Ship's movement data priority (data from GPS/DR)

Ship's movement data is set to GPS-DR with S1/S2 on the DIP switch DP-1

1. GP-VTC from NMEA port
2. GP-VTC from CI/NMEA port
3. GP-RMC from NMEA port
4. GP-RMC from CI/NMEA port
5. <48> from CIF port
6. <41> from CIF port

Ship's movement data priority (data from Current indicator)

Ship's movement data is set to Current indicator with S1/S2 on the DIP switch DP-1

1. VD-VTG from NMEA port
2. VD-VTG from CI/NMEA port
3. VD-VHW from NMEA port
4. VD-VHW from CI/NMEA port
5. CIF signal <66> from CI/NMEA port
6. <66> from CIF port

Ship's movement data priority (data from Gyro/Navigation)

Ship's movement data is set to Gyrocompass/navigation with S1/S2 on the DIP switch DP-1.

1. GP-VTG from NMEA port
2. GP-VTG from CI/NMEA port
3. GP-RMC from NMEA port
4. GP-RMC from CI/NMEA port
5. LC-VTG NMEA port
6. LC-VTG from CI/NMEA port
7. LC-RMA from NMEA port
8. LC-RMA from CI/NMEA port
9. <48> from CIF port
10. <44> from CIF port

Current data (Multi layer) priority

1. VD-CUR from NMEA port
2. VD-CUR from CI/NMEA port
3. CIF signal <76> from CI/NMEA port
4. <76> from CIF port

Current data (single layer) priority

1. VD-VDR from NMEA port
2. VD-VDR from CI/NMEA port
3. CIF signal <56> from CI/NMEA port
4. <56> from CIF port

7. PROCESSOR UNIT CSH-235/235F (BLACKBOX TYPE FOR CSH-23/23F)

7.1 Installing the Unit

When selecting a mounting location, consider the following conditions:

- Place where operating personnel are able to control the unit easily while observing the fishing ground or the area surrounding the vessel.
- Place not exposed to direct sunlight, water splashes or hot air.
- Place where maintenance and ventilation clearance shown in the outline drawings is ensured.
- Observe the compass safe distances shown on page i to prevent interference to a magnetic compass.

Mounting procedure

1. Remove the mounting base by unscrewing the two bolts at the front bottom.
2. Fix the mounting base to the table or deck by using six self-tapping screws 6x20 (supplied).
3. Place the unit on the mounting base, slide it forward and then fasten it to the mounting base with two bolts.

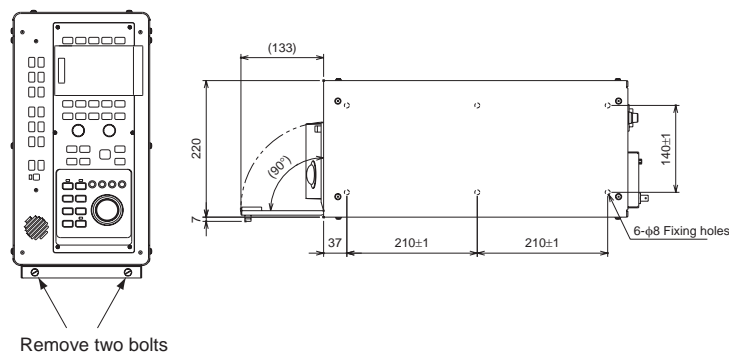

Processor unit

Top view

7.2 Monitor

Use a commercially available monitor having the specifications shown below.

- Signal: Analog RGB, 0 – 0.9 V, Positive, 75 Ω
- Synchro. signal: Horizontal, TTL level, 31.687 kHz±4 Hz, 75 Ω
Vertical, TTL level, 60.111 Hz±0.0007 Hz, 75 Ω
- Resolution: VGA, 640 x 481

Mount the monitor in portrait orientation. Note that FURUNO monitor model MU-151C can be used in portrait orientation.

7.3 Connecting cables

Fabricate the cables as shown in the section “4.4 Fabricating Cable, Assembling connectors.”
Connect the cables, referring to the interconnection diagrams at the back of this manual.

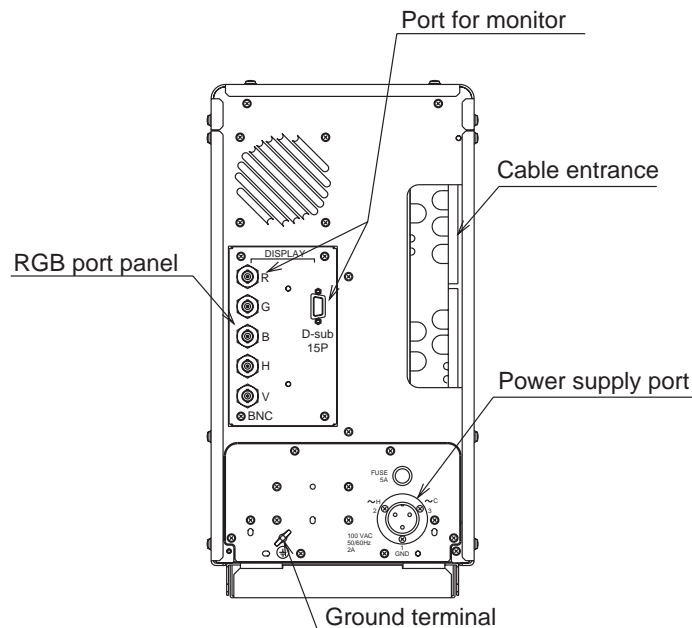

Processor unit (rear panel)

Protective earth

Attach protective earth cable (IV-8sq, shipyard supply) between the GND terminal of the processor unit and ship's body.



Connectors for Monitor

There are two kinds of video signal ports: D-sub connector (default) and BNC connectors.

- D-sub: Use interconnection cable 3COX-2P-6C (5 m or 10 m) or equivalent commercially available cable.
- BNC connector: Use five 75 Ω coaxial cables (shipyard supply). The coaxial cables are preferred in case of longer than 10 m cable run between the processor unit and monitor.

The following modification is required to use the BNC connectors.

1. Dismount the RGB port panel at the rear of the processor unit.
2. Confirming the label attached to each BNC connector, connect each connector to its corresponding port.
3. Mount the RGB port panel.

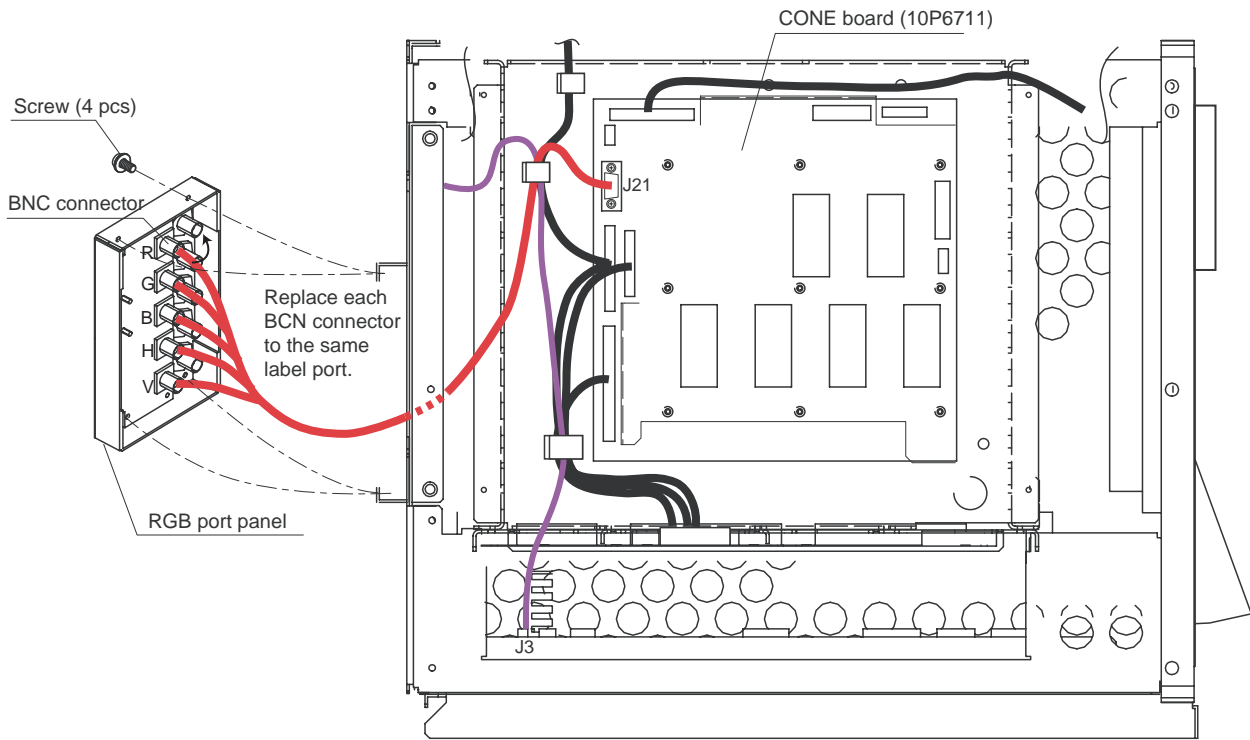



Processor unit (right side, cover removed)

PACKING LIST

10CJ-X-9851 -1 1/1

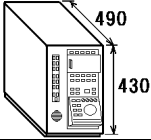
CSH-235/235K/235F/535/585/735/835

NAME	OUTLINE	DESCRIPTION/CODE	Q'TY
ユニット UNIT			
操作制御部 PROCESSOR UNIT		CSH-235 000-070-191 **	1
予備品 SPARE PARTS			
予備品 SPARE PARTS		SP10-03201 006-030-590	1
工事材料 INSTALLATION MATERIALS			
工事材料 INSTALLATION MATERIALS		CP10-06301 006-030-600	1

1.コード番号末尾の[**]は、選択品の代表型式/コードを表します。

CODE NUMBER ENDING WITH "**" INDICATES THE CODE NUMBER OF REPRESENTATIVE MATERIAL.

(略図の寸法は、参考値です。 DIMENSIONS IN DRAWING FOR REFERENCE ONLY.)

10CJ-X-9851

FURUNO

CODE NO.	006-030-590	10CJ-X-9301 -1 1/1
TYPE	SP10-03201	BOX NO. P

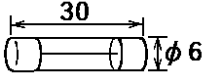
SHIP NO.		SPARE PARTS LIST FOR		U S E			SETS PER VESSEL
ITEM NO.	NAME OF PART	OUTLINE	DWG. NO. OR TYPE NO.	QUANTITY			REMARKS/CODE NO.
				WORKING		SPARE	
				PER SET	PER VES		
1	ヒューズ FUSE		FGBO-A 5A AC125V			3	000-549-064
MFR'S NAME	FURUNO ELECTRIC CO.,LTD.			DWG NO.	10CJ-X-9301		1/1

(略図の寸法は、参考値です。 DIMENSIONS IN DRAWING FOR REFERENCE ONLY.)

FURUNO

CODE NO.	006-030-600	10CJ-X-9401 -0 1/1
TYPE	CP10-06301	

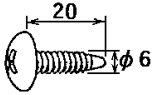
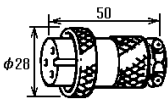
工事材料表 INSTALLATION MATERIALS					
番号 NO.	名称 NAME	略図 OUTLINE	型名 / 規格 DESCRIPTIONS	数量 Q'TY	用途 / 備考 REMARKS
1	+トラスタップ°ンネジ 1種 SELF-TAPPING SCREW		6X20 SUS304	6	
			CODE NO. 000-802-084		
2	コネクタ(NCS) CONNECTOR(NCS)		NCS-253-P	1	
			CODE NO. 000-506-503		

10CJ-X-9401

FURUNO ELECTRIC CO., LTD.
 (略図の寸法は、参考値です。 DIMENSIONS IN DRAWING FOR REFERENCE ONLY.)

FURUNO

CODE NO.	000-068-909	10BW-X-9301 -5
TYPE	SP10-01700	BOX NO. P

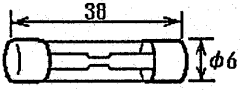
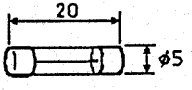
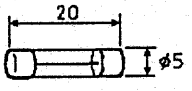
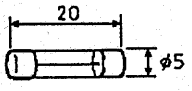
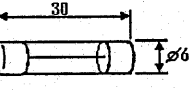
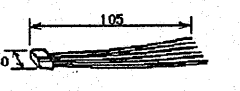
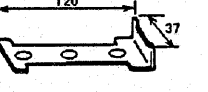
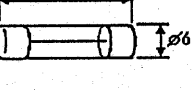
SHIP NO.		SPARE PARTS LIST FOR		U S E			SETS PER VESSEL
		カラーキャニングソナー COLOR SCANNING SONAR		CSH-21・K/22/23・K/251W/261W 271W/281W/281S/288W/24			
ITEM NO.	NAME OF PART	OUTLINE	DWG. NO. OR TYPE NO.	QUANTITY		REMARKS/CODE NO.	
				WORKING	SPARE		
				PER SET	PER VES		
1	管入りヒューズ FUSE		FGB01 30A AC250V	1		指示装置用 2 FOR DISPLAY UNIT 000-549-086	
2	ヒューズ FUSE		FGMA 3A 125V(UL)	1		指示装置用 2 FOR DISPLAY UNIT 000-111-848	
3	ヒューズ FUSE		FGMA 1A AC125V	1		指示装置用 2 FOR DISPLAY UNIT 000-126-840	
4	ヒューズ FUSE		FGMA 2A AC125V	2		指示装置用 4 FOR DISPLAY UNIT 000-126-841	
5	ヒューズ FUSE		FGAO 10A AC125V	1		指示装置用 5 FOR DISPLAY UNIT 000-126-852	
6	XHコネクタ組品 XH CONNECTOR ASSY.		10-145(13P)	1		受信装置用 1 FOR RECEIVER UNIT 006-947-380	
7	コネクタ抜き工具 CONNECTOR PULLER		10-026-6901-0		1	受信装置用 FOR RECEIVER UNIT 100-008-460	
8	ヒューズ FUSE		FGBO-A 2A AC125V	16		送振装置用 20 FOR TRANSMITTER UNIT 000-549-062	
MFR'S NAME		FURUNO ELECTRIC CO., LTD		DWG NO.		1/1	

(略図の寸法は、参考値です。 DIMENSIONS IN DRAWING FOR REFERENCE ONLY.)

C1286-P01- F

FURUNO

CODE NO.	000-068-910	10BW-X-9302 -4
TYPE	SP10-01800	BOX NO. P

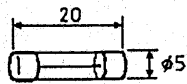
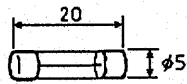
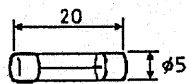
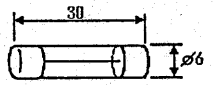
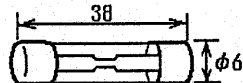
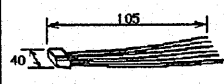
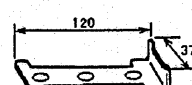
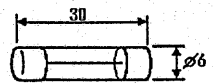
SHIP NO.		SPARE PARTS LIST FOR		U S E			SETS PER VESSEL
		CSH-21F・22F カラー・スキャニング・ソナー 23F・24F/FL COLOR SCANNING SONAR					
ITEM NO.	NAME OF PART	OUTLINE	DWG. NO. OR TYPE NO.	QUANTITY		REMARKS/CODE NO.	
				WORKING	SPARE		
				PER SET	PER VES		
1	ヒューズ FUSE		FGMA 3A 125V(UL)	1		指示装置用 FOR DISPLAY UNIT 000-111-848	
2	ヒューズ FUSE		FGMA 1A AC125V	1		指示装置用 FOR DISPLAY UNIT 000-126-840	
3	ヒューズ FUSE		FGMA 2A AC125V	2		指示装置用 FOR DISPLAY UNIT 000-126-841	
4	ヒューズ FUSE		FGAO 10A AC125V	1		指示装置用 FOR DISPLAY UNIT 000-126-852	
5	管入りヒューズ FUSE		FGB01 30A AC250V	1		指示装置用 FOR DISPLAY UNIT 000-549-086	
6	XHコネクタ組品 XH CONNECTOR ASSY.		10-145(13P)	1		受信装置用 FOR RECEIVER UNIT 006-947-380	
7	コネクタ抜き工具 CONNECTOR PULLER		10-026-6901-0		1	受信装置用 FOR RECEIVER UNIT 100-008-460	
8	ヒューズ FUSE		FGB0 5A AC250V	16		送信装置用 FOR TRANSMITTER 000-549-022	
MFR'S NAME		FURUNO ELECTRIC CO.,LTD		DWG NO.		1/1	

(略図の寸法は、参考値です。 DIMENSIONS IN DRAWING FOR REFERENCE ONLY.)

C1287-P01- E

FURUNO

CODE NO.	000-070-208	10CJ-X-9302 -0 1/1
TYPE	SP10-03300	BOX NO. P

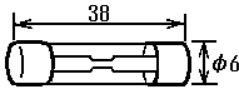
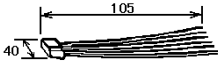
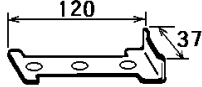
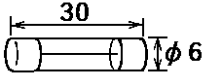
SHIP NO.		SPARE PARTS LIST FOR		U S E			SETS PER VESSEL
ITEM NO.	NAME OF PART	OUTLINE	DWG. NO. OR TYPE NO.	QUANTITY			REMARKS/CODE NO.
				WORKING		SPARE	
				PER SET	PER VES		
1	管入りヒューズ FUSE		FGB01 30A AC250V			2	指示装置用 FOR DISPLAY UNIT 000-549-086
2	XHコネクタ組品 XH CONNECTOR ASSY,		10-145(13P)			1	受信装置用 FOR RECEIVER UNIT 006-947-380
3	コネクタ抜き工具 CONNECTOR PULLER		10-026-6901-0			1	受信装置用 FOR RECEIVER UNIT 100-008-460
4	ヒューズ FUSE		FGB0-A 2A AC125V			20	送信装置用 FOR TRANSMITTER UNIT 000-549-062
MFR'S NAME		FURUNO ELECTRIC CO.,LTD.		DWG NO.	10CJ-X-9302	1/1	

(略図の寸法は、参考値です。 DIMENSIONS IN DRAWING FOR REFERENCE ONLY.)

FURUNO

CODE NO.	000-070-209	10CJ-X-9303 -0 1/1
TYPE	SP10-03400	BOX NO. P

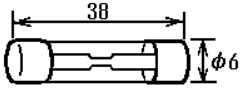
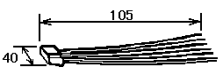
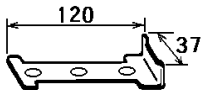
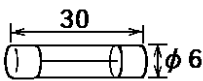
SHIP NO.		SPARE PARTS LIST FOR		U S E			SETS PER VESSEL
ITEM NO.	NAME OF PART	OUTLINE	DWG. NO. OR TYPE NO.	QUANTITY			REMARKS/CODE NO.
				WORKING		SPARE	
				PER SET	PER VES		
1	管入りヒューズ FUSE		FGB01 30A AC250V			2	指示装置用 FOR DISPLAY UNIT 000-549-086
2	XHコネクタ組品 XH CONNECTOR ASSY,		10-145(13P)			1	受信装置用 FOR RECEIVER UNIT 006-947-380
3	コネクタ抜き工具 CONNECTOR PULLER		10-026-6901-0			1	受信装置用 FOR RECEIVER UNIT 100-008-460
4	ヒューズ FUSE		FGB0 5A AC250V			20	送信装置用 FOR TRANSMITTER UNIT 000-549-022
MFR'S NAME	FURUNO ELECTRIC CO.,LTD.			DWG NO.	10CJ-X-9303		1/1

(略図の寸法は、参考値です。 DIMENSIONS IN DRAWING FOR REFERENCE ONLY.)

FURUNO

CODE NO.	006-989-010-00	10BW-X-9401 -9
TYPE	CP10-02710	1/4

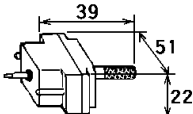
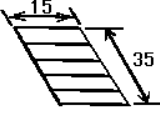
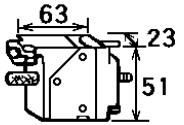
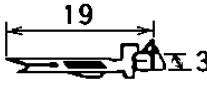
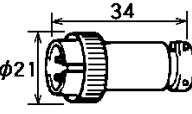
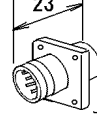
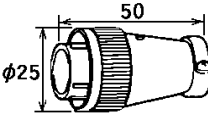
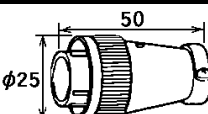
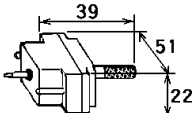
工事材料表 INSTALLATION MATERIALS					
番号 NO.	名称 NAME	略図 OUTLINE	型名 / 規格 DESCRIPTIONS	数量 Q'TY	用途 / 備考 REMARKS
1	アース線組品 GROUNDING WIRE	 L=5M	CS-120-C CODE NO. 006-937-660-00	1	外部インターフェイス工材 FOR INTERFACE UNIT
2	コネクタ(8016) CONNECTOR(8016)		008016-038-313761HVF 00-8016-038-313761HV CODE NO. 000-159-017-10 000-127-234-00	1	外部インターフェイス工材 FOR INTERFACE UNIT
3	貼りマーク.J201. STICKER.J201.		10-018-5022 CODE NO. 181-850-220-00	1	外部インターフェイス工材 FOR INTERFACE UNIT
4	コネクタ(54) CONNECTOR(54)		54-038-000-601/SC CODE NO. 000-132-081-00	1	外部インターフェイス工材 FOR INTERFACE UNIT
5	コンタクトピン(8017) CONTACT PIN(8017)		60-8017-0313-00-339 CODE NO. 000-519-542-00	38	外部インターフェイス工材 FOR INTERFACE UNIT
6	コネクタ(RM) CONNECTOR(RM)		RM15TP-2PA(71) RM15TP-2PA CODE NO. 000-159-835-10 000-503-314-00	1	外部インターフェイス工材 FOR INTERFACE UNIT
7	コネクタ(SRCN) CONNECTOR(SRCN)		SRCN2A16-7P CODE NO. 000-508-652-00	1	外部インターフェイス工材 FOR INTERFACE UNIT
8	コネクタ(SRCN) CONNECTOR(SRCN)		SRCN6A16-10P CODE NO. 000-508-663-00	4	外部インターフェイス工材 FOR INTERFACE UNIT
9	コネクタ(SRCN) CONNECTOR(SRCN)		SRCN6A16-7P CODE NO. 000-508-662-00	1	外部インターフェイス工材 FOR INTERFACE UNIT
10	コネクタ(8016) CONNECTOR(8016)		008016-038-313761HVF 00-8016-038-313761HV CODE NO. 000-159-017-10 000-127-234-00	1	指示装置工材 FOR DISPLAY UNIT

型式/コード番号が2段の場合、下段より上段に代わる過渡期品であり、どちらかが入っています。なお、品質は変わりません。

TWO TYPES AND CODES MAY BE LISTED FOR AN ITEM. THE LOWER PRODUCT MAY BE SHIPPED IN PLACE OF THE UPPER PRODUCT. QUALITY IS THE SAME.

(略図の寸法は、参考値です。DIMENSIONS IN DRAWING FOR REFERENCE ONLY.)



10BW-X-9401

FURUNO ELECTRIC CO., LTD. C1286-M01-H

FURUNO

CODE NO.	006-989-010-00	10BW-X-9401 -9
TYPE	CP10-02710	

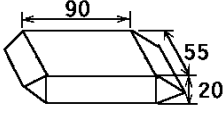
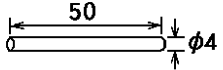
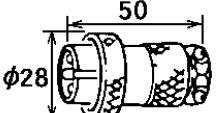
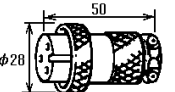
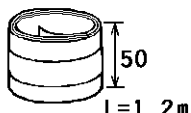
2/4

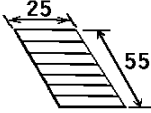
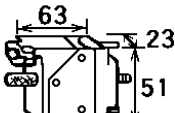
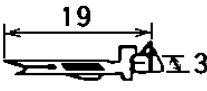
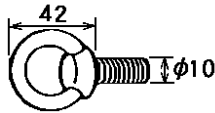
工事材料表					
INSTALLATION MATERIALS					
番号 NO.	名称 NAME	略図 OUTLINE	型名 / 規格 DESCRIPTIONS	数量 Q'TY	用途 / 備考 REMARKS
11	クーラーパテ COOLER PUTTY		200G/リ シロロ CODE NO. 000-807-621-00	2	指示装置工材 FOR DISPLAY UNIT
12	ラックスチューブ (A) INSULATION TUBE(A)		4.0X0.3 ｷﾞロ *5CM* CODE NO. 000-100-923-00	1	指示装置工材 FOR DISPLAY UNIT
13	コネクタ(NCS) CONNECTOR		NCS-252-P *ROHS* NCS-252-P CODE NO. 000-160-150-10 000-506-501-10	1	指示装置工材 FOR DISPLAY UNIT
14	コネクタ(NCS) CONNECTOR(NCS)		NCS-253-P CODE NO. 000-506-503-10	1	指示装置工材 FOR DISPLAY UNIT
15	アース板 COPPER STRAP		WEA-1004-0 CODE NO. 500-310-040-00	1	指示装置工材 FOR DISPLAY UNIT
16	コネクタ(8016) CONNECTOR		00-8016-020-313-703V CODE NO. 000-111-143-00	1	受信装置工材 FOR RECEIVER UNIT
17	P貼りマーク.11. P STICKER.11.		10-026-0619-0 CODE NO. 100-014-880-00	1	受信装置工材 FOR RECEIVER UNIT
18	コネクタ(54) CONNECTOR(54)		54-038-000-601/SC CODE NO. 000-132-081-00	3	受信装置工材 FOR RECEIVER UNIT
19	コンタクトピン(8017) CONTACT PIN (8017)		60-8017-0313-00-339 CODE NO. 000-519-542-00	114	受信装置工材 FOR RECEIVER UNIT
20	アイボルト EYE-BOLT		M10 SS41 MFN12 CODE NO. 000-862-506-00	2	受信装置工材 FOR RECEIVER UNIT

型式/コード番号が2段の場合、下段より上段に代わる過渡期品であり、どちらかが入っています。なお、品質は変わりません。

TWO TYPES AND CODES MAY BE LISTED FOR AN ITEM. THE LOWER PRODUCT MAY BE SHIPPED IN PLACE OF THE UPPER PRODUCT. QUALITY IS THE SAME.

(略図の寸法は、参考値です。 DIMENSIONS IN DRAWING FOR REFERENCE ONLY.)

10BW-X-9401

FURUNO ELECTRIC CO., LTD. C1257-M02-D

FURUNO

CODE NO.	006-989-010-00	10BW-X-9401 -9
TYPE	CP10-02710	3/4

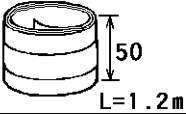
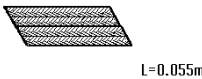
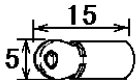
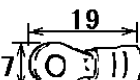
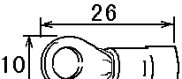
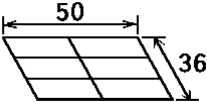
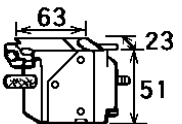
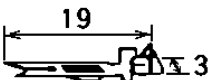
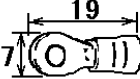
工事材料表					
INSTALLATION MATERIALS					
番号 NO.	名称 NAME	略図 OUTLINE	型名 / 規格 DESCRIPTIONS	数量 Q'TY	用途 / 備考 REMARKS
21	ミガキ平座金 FLAT WASHER		M10 SS41 MFZN2-B CODE NO. 000-864-191-00	2	受信装置工材 FOR RECEIVER UNIT
22	アス板 COPPER STRAP		WEA-1004-0 CODE NO. 500-310-040-00	1	受信装置工材 FOR RECEIVER UNIT
23	シールドスリーブ SHIELD SLEEVE		ZSK-06HF 0.055M CODE NO. 000-809-085-00	20	受信装置工材 FOR RECEIVER UNIT
24	圧着端子 CRIMP-ON LUG		FV1.25-3.7 アカ CODE NO. 000-108-699-00	15	上下装置工材 FOR HULL UNIT
25	圧着端子 CRIMP-ON LUG		FV1.25-M4 アカ CODE NO. 000-536-715-00	5	上下装置工材 FOR HULL UNIT
26	圧着端子 CRIMP-ON LUG		FV5.5-4 CODE NO. 000-538-123-00	5	上下装置工材 FOR HULL UNIT
27	貼りマーク STICKER		10-026-5002-0 CODE NO. 100-004-870-00	1	送振装置工材 FOR TRANSMITTER UNIT
28	コネクタ(54) CONNECTOR(54)		54-038-000-601/SC CODE NO. 000-132-081-00	3	送振装置工材 FOR TRANSMITTER UNIT
29	コンタクトピン(8017) CONTACT PIN (8017)		60-8017-0313-00-339 CODE NO. 000-519-542-00	120	送振装置工材 FOR TRANSMITTER UNIT
30	圧着端子 CRIMP-ON LUG		FV1.25-M4 アカ CODE NO. 000-536-715-00	5	送振装置工材 FOR TRANSMITTER UNIT

型式/コード番号が2段の場合、下段より上段に代わる過渡期品であり、どちらかが入っています。なお、品質は変わりません。

TWO TYPES AND CODES MAY BE LISTED FOR AN ITEM. THE LOWER PRODUCT MAY BE SHIPPED IN PLACE OF THE UPPER PRODUCT. QUALITY IS THE SAME.

(略図の寸法は、参考値です。 DIMENSIONS IN DRAWING FOR REFERENCE ONLY.)

10BW-X-9401

FURUNO ELECTRIC CO., LTD. C1257-M03-D

FURUNO

CODE NO.	006-989-010-00	10BW-X-9401 -9
TYPE	CP10-02710	4/4

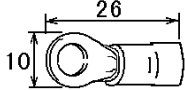
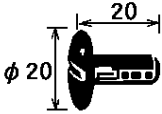
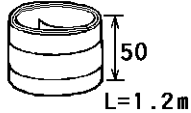
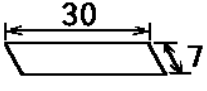
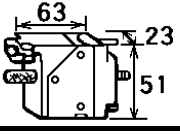
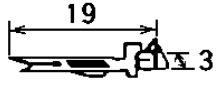
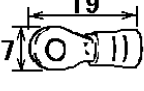
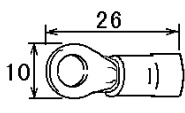
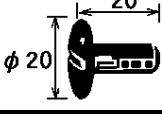
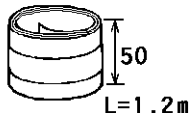
工事材料表 INSTALLATION MATERIALS					
番号 NO.	名称 NAME	略図 OUTLINE	型名 / 規格 DESCRIPTIONS	数量 Q'TY	用途 / 備考 REMARKS
31	圧着端子 CRIMP-ON LUG		FV5.5-4 CODE NO. 000-538-123-00	5	送振装置工材 FOR TRANSMITTER UNIT
32	ホールプラグ HOLE PLUG		NO.4567 CODE NO. 000-800-729-00	4	送振装置工材 FOR TRANSMITTER UNIT
33	アース板 COPPER STRAP		WEA-1004-0 CODE NO. 500-310-040-00	1	送振装置工材 FOR TRANSMITTER UNIT
34	貼りマーク.1. STICKER.1.		10-026-7018-0 CODE NO. 100-008-630-00	1	電源装置工材 FOR POWER UNIT
35	コネクタ(54) CONNECTOR(54)		54-038-000-601/SC CODE NO. 000-132-081-00	1	電源装置工材 FOR POWER UNIT
36	コンタクトピン(8017) CONTACT PIN (8017)		60-8017-0313-00-339 CODE NO. 000-519-542-00	38	電源装置工材 FOR POWER UNIT
37	圧着端子 CRIMP-ON LUG		FV1.25-M4 アカ CODE NO. 000-536-715-00	6	電源装置工材 FOR POWER UNIT
38	圧着端子 CRIMP-ON LUG		FV5.5-4 CODE NO. 000-538-123-00	15	電源装置工材 FOR POWER UNIT
39	ホールプラグ HOLE PLUG		NO.4567 CODE NO. 000-800-729-00	4	電源装置工材 FOR POWER UNIT
40	アース板 COPPER STRAP		WEA-1004-0 CODE NO. 500-310-040-00	1	電源装置工材 FOR POWER UNIT

型式/コード番号が2段の場合、下段より上段に代わる過渡期品であり、どちらかが入っています。なお、品質は変わりません。

TWO TYPES AND CODES MAY BE LISTED FOR AN ITEM. THE LOWER PRODUCT MAY BE SHIPPED IN PLACE OF THE UPPER PRODUCT. QUALITY IS THE SAME.

(略図の寸法は、参考値です。 DIMENSIONS IN DRAWING FOR REFERENCE ONLY.)

10BW-X-9401

FURUNO ELECTRIC CO., LTD. G1257-M04-D

FURUNO

		CODE NO.	10BW-X-9405 -3		
		TYPE	1/1		
工事材料表 INSTALLATION MATERIALS		CSH-21/K/F・22/F 23/F/FL/K・24/F/FL 53・55・80・81・82・83 84・88・288W	カラーレーザリングソナー COLOR SCANNING SONAR		
番号 NO.	名称 NAME	略図 OUTLINE	型名/規格 DESCRIPTIONS	数量 Q'TY	用途/備考 REMARKS
1	6ツイステークーブル 6P TWISTED PAIR CABLE	 L=5m	CO-SPEV-SB 0.3X6P	1	
	CODE NO.		000-100-992		

C1286-M05-D

FURUNO ELECTRIC CO., LTD

(略図の寸法は、参考値です。 DIMENSIONS IN DRAWING FOR REFERENCE ONLY.)

FURUNO

CODE NO.	006-959-800-00	10CC-X-9401 -3 1/5
TYPE	CP10-03410	

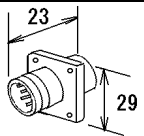
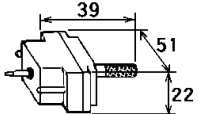
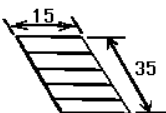
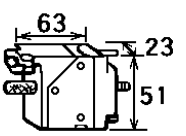
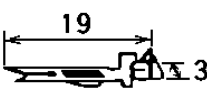
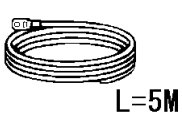
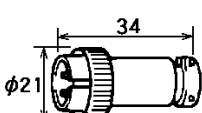
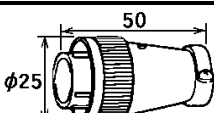
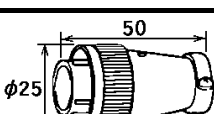
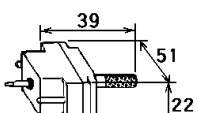
工事材料表 INSTALLATION MATERIALS					
番号 NO.	名称 NAME	略図 OUTLINE	型名 / 規格 DESCRIPTIONS	数量 Q'TY	用途 / 備考 REMARKS
1	コネクタ (SRCN) CONNECTOR (SRCN)		SRCN2A16-7P CODE NO. 000-508-652-00	1	外部インターフェイスユニット用 FOR DATA INTERFACE UNIT
2	コネクタ (8016) CONNECTOR (8016)		008016-038-313761HVF 00-8016-038-313761HV CODE NO. 000-159-017-10 000-127-234-00	1	外部インターフェイスユニット用 FOR DATA INTERFACE UNIT
3	貼りマーク .J201. STICKER .J201.		10-018-5022 CODE NO. 181-850-220-00	1	外部インターフェイスユニット用 FOR DATA INTERFACE UNIT
4	コネクタ (54) CONNECTOR (54)		54-038-000-601/SC CODE NO. 000-132-081-00	1	外部インターフェイスユニット用 FOR DATA INTERFACE UNIT
5	コンタクトピン (8017) CONTACT PIN (8017)		60-8017-0313-00-339 CODE NO. 000-519-542-00	38	外部インターフェイスユニット用 FOR DATA INTERFACE UNIT
6	アース線組品 GROUNDING WIRE		CS-120-C CODE NO. 006-937-660-00	1	外部インターフェイスユニット用 FOR DATA INTERFACE UNIT
7	コネクタ (RM) CONNECTOR (RM)		RM15TP-2PA (71) RM15TP-2PA CODE NO. 000-159-835-10 000-503-314-00	1	外部インターフェイスユニット用 FOR DATA INTERFACE UNIT
8	コネクタ (SRCN) CONNECTOR (SRCN)		SRCN6A16-10P CODE NO. 000-508-663-00	4	外部インターフェイスユニット用 FOR DATA INTERFACE UNIT
9	コネクタ (SRCN) CONNECTOR (SRCN)		SRCN6A16-7P CODE NO. 000-508-662-00	1	外部インターフェイスユニット用 FOR DATA INTERFACE UNIT
10	コネクタ (8016) CONNECTOR (8016)		008016-038-313761HVF 00-8016-038-313761HV CODE NO. 000-159-017-10 000-127-234-00	1	指示装置用 FOR DISPLAY UNIT

型式/コード番号が2段の場合、下段より上段に代わる過渡期品であり、どちらかが入っています。なお、品質は変わりません。

TWO TYPES AND CODES MAY BE LISTED FOR AN ITEM. THE LOWER PRODUCT MAY BE SHIPPED IN PLACE OF THE UPPER PRODUCT. QUALITY IS THE SAME.

(略図の寸法は、参考値です。 DIMENSIONS IN DRAWING FOR REFERENCE ONLY.)

10CC-X-9401

FURUNO ELECTRIC CO., LTD. C1292-M01-B

FURUNO

CODE NO.	006-959-800-00	10CC-X-9401 -3 2/5
TYPE	CP10-03410	

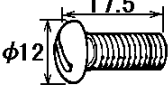
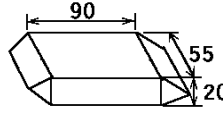
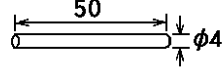
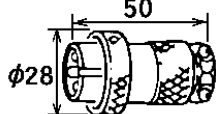
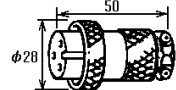
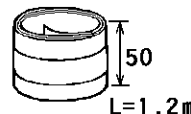
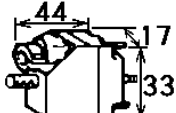
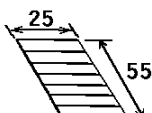
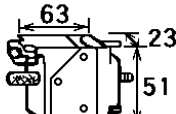
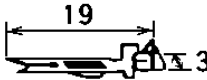
工事材料表 INSTALLATION MATERIALS					
番号 NO.	名称 NAME	略図 OUTLINE	型名 / 規格 DESCRIPTIONS	数量 Q'TY	用途 / 備考 REMARKS
11	M8化粧ビス PANEL SCREW		10-054-1144-0 CODE NO. 100-195-970-00	4	指示装置用 FOR DISPLAY UNIT
12	クーラパテ COOLER PUTTY		200G入り 缶入り CODE NO. 000-807-621-00	2	指示装置用 FOR DISPLAY UNIT
13	イラックスチューブ (A) INSULATION TUBE(A)		4.0X0.3 缶入り *5CM* CODE NO. 000-100-923-00	1	指示装置用 FOR DISPLAY UNIT
14	コネクタ(NCS) CONNECTOR		NCS-252-P *ROHS* NCS-252-P CODE NO. 000-160-150-10 000-506-501-10	1	指示装置用 FOR DISPLAY UNIT
15	コネクタ(NCS) CONNECTOR(NCS)		NCS-253-P CODE NO. 000-506-503-10	1	指示装置用 FOR DISPLAY UNIT
16	アース板 COPPER STRAP		WEA-1004-0 CODE NO. 500-310-040-00	1	指示装置用 FOR DISPLAY UNIT
17	コネクタ(8016) CONNECTOR		00-8016-020-313-703V CODE NO. 000-111-143-00	1	受信装置用 FOR RECEIVER UNIT
18	P貼りマーク.11. P STICKER.11.		10-026-0619-0 CODE NO. 100-014-880-00	1	受信装置用 FOR RECEIVER UNIT
19	コネクタ(54) CONNECTOR(54)		54-038-000-601/SC CODE NO. 000-132-081-00	3	受信装置用 FOR RECEIVER UNIT
20	コンタクトピン(8017) CONTACT PIN(8017)		60-8017-0313-00-339 CODE NO. 000-519-542-00	114	受信装置用 FOR RECEIVER UNIT

型式/コード番号が2段の場合、下段より上段に代わる過渡期品であり、どちらかが入っています。なお、品質は変わりません。

TWO TYPES AND CODES MAY BE LISTED FOR AN ITEM. THE LOWER PRODUCT MAY BE SHIPPED IN PLACE OF THE UPPER PRODUCT. QUALITY IS THE SAME.

(略図の寸法は、参考値です。 DIMENSIONS IN DRAWING FOR REFERENCE ONLY.)





10CC-X-9401

FURUNO ELECTRIC CO., LTD.

C1292-M02-B

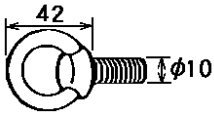
FURUNO

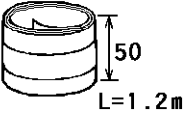
CODE NO.	006-959-800-00	10CC-X-9401 -3 3/5
TYPE	CP10-03410	

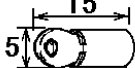
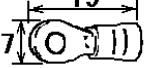
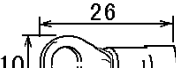
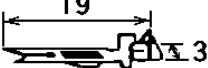
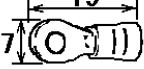
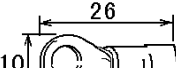
工事材料表 INSTALLATION MATERIALS					
番号 NO.	名称 NAME	略図 OUTLINE	型名 / 規格 DESCRIPTIONS	数量 Q'TY	用途 / 備考 REMARKS
21	アイボルト EYE-BOLT		M10 SS41 MFN12 CODE NO. 000-862-506-00	2	受信装置用 FOR RECEIVER UNIT
22	ミガキ平座金 FLAT WASHER		M10 SS41 MFZN2-B CODE NO. 000-864-191-00	2	受信装置用 FOR RECEIVER UNIT
23	アース板 COPPER STRAP		WEA-1004-0 CODE NO. 500-310-040-00	1	受信装置用 FOR RECEIVER UNIT
24	シールドスリーブ SHIELD SLEEVE		ZSK-06HF 0.055M CODE NO. 000-809-085-00	20	受信装置用 FOR RECEIVER UNIT
25	圧着端子 CRIMP-ON LUG		FV1.25-3.7 アカ CODE NO. 000-108-699-00	15	上下装置用 FOR HULL UNIT
26	圧着端子 CRIMP-ON LUG		FV1.25-M4 アカ CODE NO. 000-536-715-00	5	上下装置用 FOR HULL UNIT
27	圧着端子 CRIMP-ON LUG		FV5.5-4 CODE NO. 000-538-123-00	5	上下装置用 FOR HULL UNIT
28	コンタクトピン (8017) CONTACT PIN (8017)		60-8017-0313-00-339 CODE NO. 000-519-542-00	120	送振装置用 FOR TRANSMITTER UNIT
29	圧着端子 CRIMP-ON LUG		FV1.25-M4 アカ CODE NO. 000-536-715-00	5	送振装置用 FOR TRANSMITTER UNIT
30	圧着端子 CRIMP-ON LUG		FV5.5-4 CODE NO. 000-538-123-00	5	送振装置用 FOR TRANSMITTER UNIT

型式/コード番号が2段の場合、下段より上段に代わる過渡期品であり、どちらかが入っています。なお、品質は変わりません。

TWO TYPES AND CODES MAY BE LISTED FOR AN ITEM. THE LOWER PRODUCT MAY BE SHIPPED IN PLACE OF THE UPPER PRODUCT. QUALITY IS THE SAME.

(略図の寸法は、参考値です。DIMENSIONS IN DRAWING FOR REFERENCE ONLY.)

10CC-X-9401

C1292-M03-B

FURUNO ELECTRIC CO., LTD.

FURUNO

CODE NO.	006-959-800-00	10CC-X-9401 -3
TYPE	CP10-03410	4/5

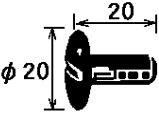
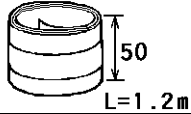
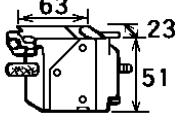
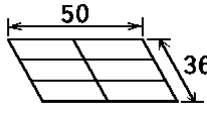
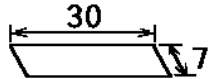
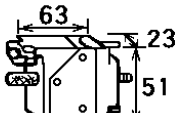
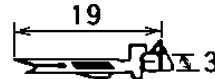
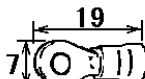
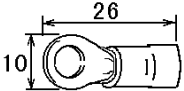
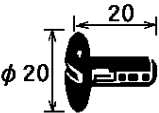
工事材料表 INSTALLATION MATERIALS					
番号 NO.	名称 NAME	略図 OUTLINE	型名 / 規格 DESCRIPTIONS	数量 Q'TY	用途 / 備考 REMARKS
31	ホールプラグ HOLE PLUG		NO.4567 CODE NO. 000-800-729-00	4	送振装置用 FOR TRANSMITTER UNIT
32	アス板 COPPER STRAP		WEA-1004-0 CODE NO. 500-310-040-00	1	送振装置用 FOR TRANSMITTER UNIT
33	コネクタ(54) CONNECTOR(54)		54-038-000-601/SC CODE NO. 000-132-081-00	3	送振装置用 FOR TRANSMITTER UNIT
34	貼りマーク STICKER		10-026-5002-0 CODE NO. 100-004-870-00	1	送振装置用 FOR TRANSMITTER UNIT
35	貼りマーク.1. STICKER.1.		10-026-7018-0 CODE NO. 100-008-630-00	1	電源装置用 FOR POWER SUPPLY UNIT
36	コネクタ(54) CONNECTOR(54)		54-038-000-601/SC CODE NO. 000-132-081-00	1	電源装置用 FOR POWER SUPPLY UNIT
37	コンタクトピン(8017) CONTACT PIN (8017)		60-8017-0313-00-339 CODE NO. 000-519-542-00	38	電源装置用 FOR POWER SUPPLY UNIT
38	圧着端子 CRIMP-ON LUG		FV1.25-M4 アカ CODE NO. 000-536-715-00	6	電源装置用 FOR POWER SUPPLY UNIT
39	圧着端子 CRIMP-ON LUG		FV5.5-4 CODE NO. 000-538-123-00	15	電源装置用 FOR POWER SUPPLY UNIT
40	ホールプラグ HOLE PLUG		NO.4567 CODE NO. 000-800-729-00	4	電源装置用 FOR POWER SUPPLY UNIT

型式/コード番号が2段の場合、下段より上段に代わる過渡期品であり、どちらかが入っています。なお、品質は変わりません。

TWO TYPES AND CODES MAY BE LISTED FOR AN ITEM. THE LOWER PRODUCT MAY BE SHIPPED IN PLACE OF THE UPPER PRODUCT. QUALITY IS THE SAME.

(略図の寸法は、参考値です。 DIMENSIONS IN DRAWING FOR REFERENCE ONLY.)

10CC-X-9401

FURUNO ELECTRIC CO., LTD. C1292-M04-B

FURUNO

CODE NO.	006-959-800-00	10CC-X-9401 -3 5/5
TYPE	CP10-03410	

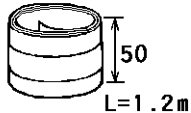
工事材料表 INSTALLATION MATERIALS					
番号 NO.	名称 NAME	略図 OUTLINE	型名 / 規格 DESCRIPTIONS	数量 Q'TY	用途 / 備考 REMARKS
41	ア-ス板 COPPER STRAP		WEA-1004-0 CODE NO. 500-310-040-00	1	電源装置用 FOR POWER SUPPLY UNIT

型式/コード番号が2段の場合、下段より上段に代わる過渡期品であり、どちらかが入っています。なお、品質は変わりません。

TWO TYPES AND CODES MAY BE LISTED FOR AN ITEM. THE LOWER PRODUCT MAY BE SHIPPED IN PLACE OF THE UPPER PRODUCT. QUALITY IS THE SAME.

(略図の寸法は、参考値です。 DIMENSIONS IN DRAWING FOR REFERENCE ONLY.)



10CC-X-9401

FURUNO ELECTRIC CO., LTD.

C1292-M05-B

FURUNO

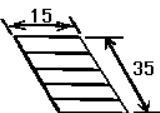
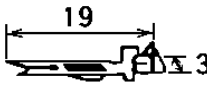
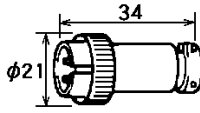
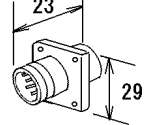
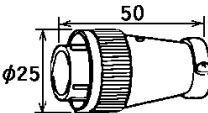
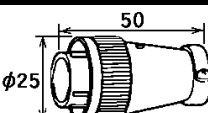
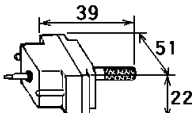
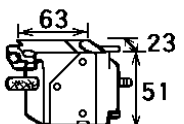
CODE NO.	006-030-650-00	10CJ-X-9402 -1
TYPE	CP10-06410	1/4

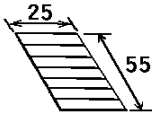
工事材料表 INSTALLATION MATERIALS					
番号 NO.	名称 NAME	略図 OUTLINE	型名/規格 DESCRIPTIONS	数量 Q'TY	用途/備考 REMARKS
1	貼りマーク.J201. STICKER.J201.		10-018-5022 CODE NO. 181-850-220-00	1	外部インターフェイス工材 FOR INTERFACE UNIT
2	コンタクトピン(8017) CONTACT PIN (8017)		60-8017-0313-00-339 CODE NO. 000-519-542-00	38	外部インターフェイス工材 FOR INTERFACE UNIT
3	コネクタ(RM) CONNECTOR (RM)		RM15TP-2PA(71) RM15TP-2PA CODE NO. 000-159-835-10 000-503-314-00	1	外部インターフェイス工材 FOR INTERFACE UNIT
4	コネクタ(SRCN) CONNECTOR (SRCN)		SRCN2A16-7P CODE NO. 000-508-652-00	1	外部インターフェイス工材 FOR INTERFACE UNIT
5	コネクタ(SRCN) CONNECTOR (SRCN)		SRCN6A16-10P CODE NO. 000-508-663-00	4	外部インターフェイス工材 FOR INTERFACE UNIT
6	コネクタ(SRCN) CONNECTOR (SRCN)		SRCN6A16-7P CODE NO. 000-508-662-00	1	外部インターフェイス工材 FOR INTERFACE UNIT
7	コネクタ(8016) CONNECTOR (8016)		008016-038-313761HVF 00-8016-038-313761HV CODE NO. 000-159-017-10 000-127-234-00	1	外部インターフェイス工材 FOR INTERFACE UNIT
8	コネクタ(54) CONNECTOR (54)		54-038-000-601/SC CODE NO. 000-132-081-00	1	外部インターフェイス工材 FOR INTERFACE UNIT
9	アース線組品 GROUNDING WIRE		CS-120-C CODE NO. 006-937-660-00	1	外部インターフェイス工材 FOR INTERFACE UNIT
10	P貼りマーク.11. P STICKER.11.		10-026-0619-0 CODE NO. 100-014-880-00	1	受信装置工材 FOR RECEIVER UNIT

型式/コード番号が2段の場合、下段より上段に代わる過渡期品であり、どちらかが入っています。なお、品質は変わりません。

TWO TYPES AND CODES MAY BE LISTED FOR AN ITEM. THE LOWER PRODUCT MAY BE SHIPPED IN PLACE OF THE UPPER PRODUCT. QUALITY IS THE SAME.





(略図の寸法は、参考値です。DIMENSIONS IN DRAWING FOR REFERENCE ONLY.)

10CJ-X-9402

FURUNO ELECTRIC CO., LTD.

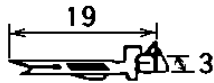
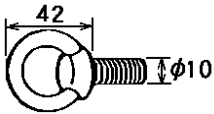
FURUNO

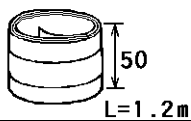
CODE NO.	006-030-650-00	10CJ-X-9402 -1 2/4
TYPE	CP10-06410	

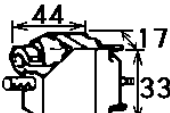
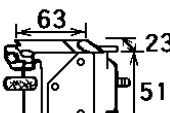
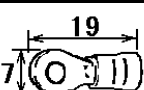
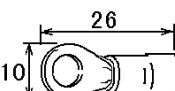
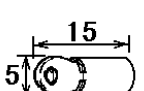
工事材料表 INSTALLATION MATERIALS					
番号 NO.	名称 NAME	略図 OUTLINE	型名 / 規格 DESCRIPTIONS	数量 Q'TY	用途 / 備考 REMARKS
11	コネクタピン (8017) CONTACT PIN (8017)		60-8017-0313-00-339 CODE NO. 000-519-542-00	114	受信装置工材 FOR RECEIVER UNIT
12	アイボルト EYE-BOLT		M10 SS41 MFN12 CODE NO. 000-862-506-00	2	受信装置工材 FOR RECEIVER UNIT
13	ミガキ平座金 FLAT WASHER		M10 SS41 MFZN2-B CODE NO. 000-864-191-00	2	受信装置工材 FOR RECEIVER UNIT
14	アース板 COPPER STRAP		WEA-1004-0 CODE NO. 500-310-040-00	1	受信装置工材 FOR RECEIVER UNIT
15	シールドスリーブ SHIELD SLEEVE		ZSK-06HF 0.055M CODE NO. 000-809-085-00	20	受信装置工材 FOR RECEIVER UNIT
16	コネクタ (8016) CONNECTOR		00-8016-020-313-703V CODE NO. 000-111-143-00	1	受信装置工材 FOR TRANSCEIVER UNIT
17	コネクタ (54) CONNECTOR (54)		54-038-000-601/SC CODE NO. 000-132-081-00	3	受信装置工材 FOR RECEIVER UNIT
18	圧着端子 CRIMP-ON LUG		FV1.25-M4 アカ CODE NO. 000-536-715-00	5	上下装置工材 FOR HULL UNIT
19	圧着端子 CRIMP-ON LUG		FV5.5-4 CODE NO. 000-538-123-00	5	上下装置工材 FOR HULL UNIT
20	圧着端子 CRIMP-ON LUG		FV1.25-3.7 アカ CODE NO. 000-108-699-00	15	上下装置工材 FOR RECEIVER UNIT

型式/コード番号が2段の場合、下段より上段に代わる過渡期品であり、どちらかが入っています。なお、品質は変わりません。

TWO TYPES AND CODES MAY BE LISTED FOR AN ITEM. THE LOWER PRODUCT MAY BE SHIPPED IN PLACE OF THE UPPER PRODUCT. QUALITY IS THE SAME.

(略図の寸法は、参考値です。 DIMENSIONS IN DRAWING FOR REFERENCE ONLY.)

10CJ-X-9402

FURUNO ELECTRIC CO., LTD.

FURUNO

CODE NO.	006-030-650-00	10CJ-X-9402 -1
TYPE	CP10-06410	3/4

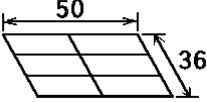
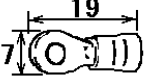
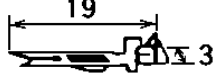
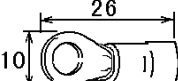
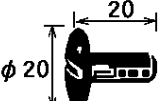
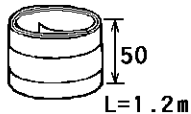
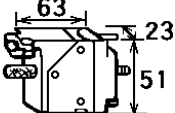
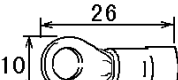
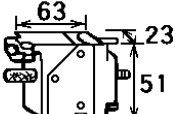
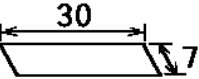
工事材料表 INSTALLATION MATERIALS					
番号 NO.	名称 NAME	略図 OUTLINE	型名 / 規格 DESCRIPTIONS	数量 Q'TY	用途 / 備考 REMARKS
21	貼りマーク STICKER		10-026-5002-0 CODE NO. 100-004-870-00	1	送信装置工材 FOR TRANSMITTER UNIT
22	圧着端子 CRIMP-ON LUG		FV1.25-M4 7カ CODE NO. 000-536-715-00	5	送信装置工材 FOR TRANSMITTER UNIT
23	コンタクトピン (8017) CONTACT PIN (8017)		60-8017-0313-00-339 CODE NO. 000-519-542-00	120	送信装置工材 FOR TRANSMITTER UNIT
24	圧着端子 CRIMP-ON LUG		FV5.5-4 CODE NO. 000-538-123-00	5	送信装置工材 FOR TRANSMITTER UNIT
25	ホールプラグ HOLE PLUG		NO.4567 CODE NO. 000-800-729-00	4	送信装置工材 FOR TRANSMITTER UNIT
26	アース板 COPPER STRAP		WEA-1004-0 CODE NO. 500-310-040-00	1	送信装置工材 FOR TRANSMITTER UNIT
27	コネクタ (54) CONNECTOR (54)		54-038-000-601/SC CODE NO. 000-132-081-00	3	送信装置工材 FOR TRANSMITTER UNIT
28	圧着端子 CRIMP-ON LUG		FV5.5-4 CODE NO. 000-538-123-00	15	電源装置工材 FOR POWER UNIT
29	コネクタ (54) CONNECTOR (54)		54-038-000-601/SC CODE NO. 000-132-081-00	1	電源装置工材 FOR POWER UNIT
30	貼りマーク.1. STICKER.1.		10-026-7018-0 CODE NO. 100-008-630-00	1	電源装置工材 FOR POWER UNIT

型式/コード番号が2段の場合、下段より上段に代わる過渡期品であり、どちらかが入っています。なお、品質は変わりません。

TWO TYPES AND CODES MAY BE LISTED FOR AN ITEM. THE LOWER PRODUCT MAY BE SHIPPED IN PLACE OF THE UPPER PRODUCT. QUALITY IS THE SAME.

(略図の寸法は、参考値です。DIMENSIONS IN DRAWING FOR REFERENCE ONLY.)

10CJ-X-9402

FURUNO ELECTRIC CO., LTD.

FURUNO

CODE NO.	006-030-650-00	10CJ-X-9402 -1 4/4
TYPE	CP10-06410	

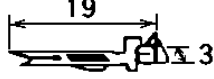
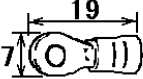
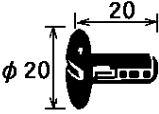
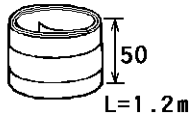
工事材料表 INSTALLATION MATERIALS					
番号 NO.	名称 NAME	略図 OUTLINE	型名 / 規格 DESCRIPTIONS	数量 Q'TY	用途 / 備考 REMARKS
31	コンタクトピン (8017) CONTACT PIN (8017)		60-8017-0313-00-339	38	電源装置工材 FOR POWER UNIT
			CODE NO. 000-519-542-00		
32	圧着端子 CRIMP-ON LUG		FV1.25-M4 アカ	6	電源装置工材 FOR POWER UNIT
			CODE NO. 000-536-715-00		
33	ホールプラグ HOLE PLUG		NO.4567	4	電源装置工材 FOR POWER UNIT
			CODE NO. 000-800-729-00		
34	アース板 COPPER STRAP		WEA-1004-0	1	電源装置工材 FOR POWER UNIT
			CODE NO. 500-310-040-00		

型式/コード番号が2段の場合、下段より上段に代わる過渡期品であり、どちらかが入っています。なお、品質は変わりません。

TWO TYPES AND CODES MAY BE LISTED FOR AN ITEM. THE LOWER PRODUCT MAY BE SHIPPED IN PLACE OF THE UPPER PRODUCT. QUALITY IS THE SAME.

(略図の寸法は、参考値です。 DIMENSIONS IN DRAWING FOR REFERENCE ONLY.)

10CJ-X-9402

FURUNO ELECTRIC CO., LTD.

FURUNO

CODE NO.	006-027-830	10C1-X-9501 -2
TYPE	FP10-01801	1/1

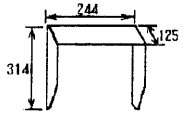
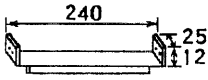
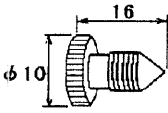
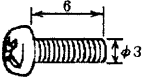
付属品表 ACCESSORIES					
番号 NO.	名称 NAME	略図 OUTLINE	型名/規格 DESCRIPTIONS	数量 Q'TY	用途/備考 REMARKS
1	フード HOOD		10-062-1601-0	1	
			CODE NO. 100-250-550		
2	フード取り付け金具 HOOD MOUNTING PLATE		16-062-1602-0	1	
			CODE NO. 100-250-560		
3	フィルタービス FILTER MOUNTING SCREW		66-007-1222-0	1	
			CODE NO. 860-712-220		
4	+ハ イント 小ネジ BINDING HEAD SCREW		M3X6 C2700Wホリシール ク ロ ナイロンワッシャツキ	4	
			CODE NO. 000-800-582		



DWG NO. C1307-F01- B

FURUNO ELECTRIC CO., LTD.

(略図の寸法は、参考値です。 DIMENSIONS IN DRAWING FOR REFERENCE ONLY.)

FURUNO

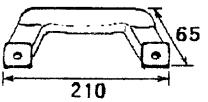
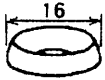
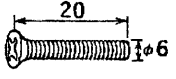
CODE NO.	006-989-020	10BW-X-9505 -1 1/1
TYPE	FP10-01201	

付属品表 ACCESSORIES					
番号 NO.	名称 NAME	略図 OUTLINE	型名/規格 DESCRIPTIONS	数量 Q'TY	用途/備考 REMARKS
1	取手 HANDLE		14-002-1125-2	2	
			CODE NO. 840-211-252		
2	ロゼット座金 ROSETTE WASHER		M6 C2700W ホリシール クロ	4	
			CODE NO. 000-864-910		
3	+丸皿小ネジ OVAL COUNTERSUNK HEAD SCREW		M6X20 C2700W ホリシール クロ	4	
			CODE NO. 000-861-475		
4	波座金 WAVE WASHER		WW-6 SUS	4	
			CODE NO. 000-864-350		

DWG NO. C1286-F01- F

FURUNO ELECTRIC CO., LTD.

(略図の寸法は、参考値です。 DIMENSIONS IN DRAWING FOR REFERENCE ONLY.)

FURUNO

CODE NO.	006-989-040	10BW-X-9504 -1 1/1
TYPE	FP10-01203	

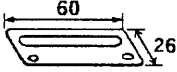
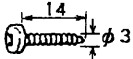
付属品表 ACCESSORIES					
番号 NO.	名称 NAME	略图 OUTLINE	型名/規格 DESCRIPTIONS	数量 Q'TY	用途/備考 REMARKS
1	掛具 HOOK		10-026-8226-1	1	
			CODE NO. 100-008-801		
2	+ナハ`Pタイトネジ` SCREW		3X14 SWCH18A MFZN-2-C	2	
			CODE NO. 000-800-172		

DWG NO.

C1286-F04- B

FURUNO ELECTRIC CO., LTD.

(略図の寸法は、参考値です。 DIMENSIONS IN DRAWING FOR REFERENCE ONLY.)

FURUNO

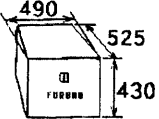
		CODE NO.			10BW-X-9501 -5
		TYPE			1/1
付属品表 ACCESSORIES		CSH-21/F/K/216/216F, CSH-23/F/K/FL CSH-53, 58 CSH-71, 73 CSH-81, 83			
番号 NO.	名称 NAME	略図 OUTLINE	型名/規格 DESCRIPTIONS		数量 Q'TY
1	ナイロンカバー PLASTIC COVER		10-051-1031		1
			CODE NO.	000-803-289	

DWG NO. C1286-F05- B

FURUNO ELECTRIC CO., LTD.

(略図の寸法は、参考値です。 DIMENSIONS IN DRAWING FOR REFERENCE ONLY.)

FURUNO

CODE NO.	006-908-550	10CM-X-9501 -1
TYPE	FP10-01901	

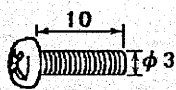
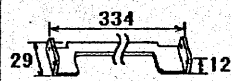
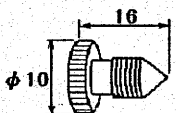
付属品表 ACCESSORIES		CSH-24/24F/24FL/84 カラースキニングソナー COLOR SCANNING SONAR			
番号 NO.	名称 NAME	略図 OUTLINE	型名/規格 DESCRIPTIONS	数量 Q'TY	用途/備考 REMARKS
1	+ハインド小ネジ BINDING HEAD SCREW		M3X10 C2700Wホリシール クロイロワッシャ付	4	
			CODE NO.		
2	フード取付金具 HOOD FIXTURE		10-064-1602-0	1	
			CODE NO.		
3	フィルタービス FILTER MOUNTING SCREW		66-007-1222-0	1	
			CODE NO.		

C1310-F01-B
FURUNO ELECTRIC CO., LTD

(略図の寸法は、参考値です。 DIMENSIONS IN DRAWING FOR REFERENCE ONLY.)

FURUNO

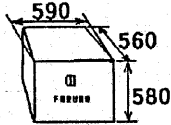
		CODE NO.			10CB-X-9501 -2
		TYPE			1/1
付属品表		CSH-288W/88/22/22F 72/82/24/24F/24FL 84		カラーキャニングソナー COLOR SCANNING SONAR	
ACCESSORIES					
番号 NO.	名称 NAME	略図 OUTLINE	型名/規格 DESCRIPTIONS	数量 Q'TY	用途/備考 REMARKS
1	ナイロンカバー PLASTIC COVER		10-054-1021	1	
			CODE NO.		

C1310-F03- A

FURUNO ELECTRIC CO., LTD

(略図の寸法は、参考値です。 DIMENSIONS IN DRAWING FOR REFERENCE ONLY.)

FURUNO

		CODE NO.			10CP-X-9501 -0
		TYPE			1/1
付属品表 ACCESSORIES		CSH-23/23F/24/24F/53/58/73/83/84/			
番号 NO.	名称 NAME	略図 OUTLINE	型名/規格 DESCRIPTIONS		数量 Q'TY
1	RAMカード組品		00RAM256C-001		1
	RAM CARD		CODE NO.	004-321-070	

DWG NO.

C1307-F02- A

FURUNO ELECTRIC CO., LTD.

(略図の寸法は、参考値です。 DIMENSIONS IN DRAWING FOR REFERENCE ONLY.)

FURUNO

CODE NO.		10CM-X-9502 -0
TYPE		1/1

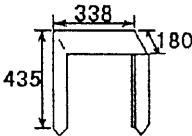
付属品表		CSH-24/24F/24FL/84		カラースキャニングソナー	
ACCESSORIES				COLOR SCANNING SONAR	
番号 NO.	名称 NAME	略図 OUTLINE	型名/規格 DESCRIPTIONS	数量 Q'TY	用途/備考 REMARKS
1	フード HOOD		10-064-1601-0	1	
			CODE NO. 100-253-710		

C1310-F04- A
 FURUNO ELECTRIC CO., LTD

(略図の寸法は、参考値です。 DIMENSIONS IN DRAWING FOR REFERENCE ONLY.)



表1 TABLE 1

寸法区分(mm) DIMENSION	公差(mm) TOLERANCE
0 < L ≤ 50	±1.5
50 < L ≤ 100	±2.5
100 < L ≤ 500	±3
500 < L ≤ 1000	±4

注記

- 1) #印寸法は最小サービス空間寸法とする
- 2) 指定なき寸法公差は表1による。

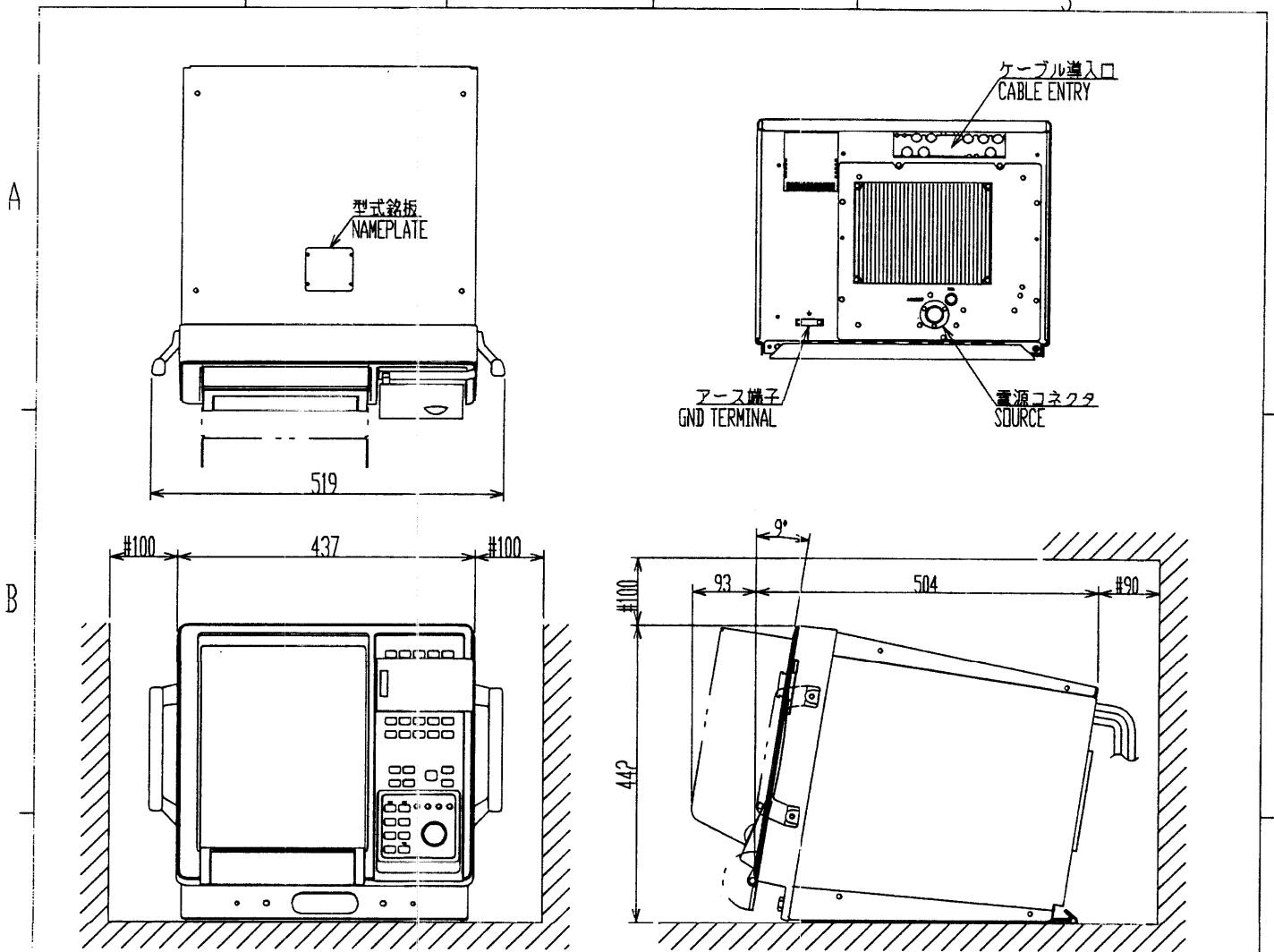
NOTE

- 1. #: RECOMMENDED SERVICE CLEARANCE.
- 2. TABLE 1 INDICATES TOLERANCE OF DIMENSIONS.

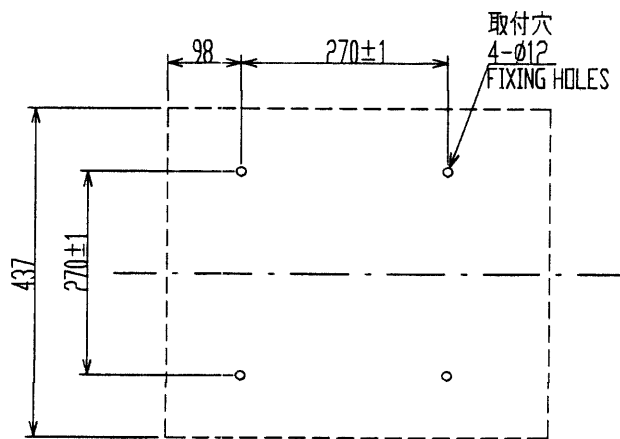

DRAWN Jun 12 '01 LYAMASAKI		TITLE CSH-230/236/530/536/731/736/580/586/830
CHECKED June 12 '01 T. Kimi		名称 指示装置
APPROVED June 12 '01 S. Yoshida	CSH-53/73/83/58 CSH-23/F/K	外寸図
SCALE 1/10	MASS 35 ±10% kg	NAME DISPLAY UNIT
DWG.No. C1307-G01-E	10-062-1000-G0	OUTLINE DRAWING

FURUNO

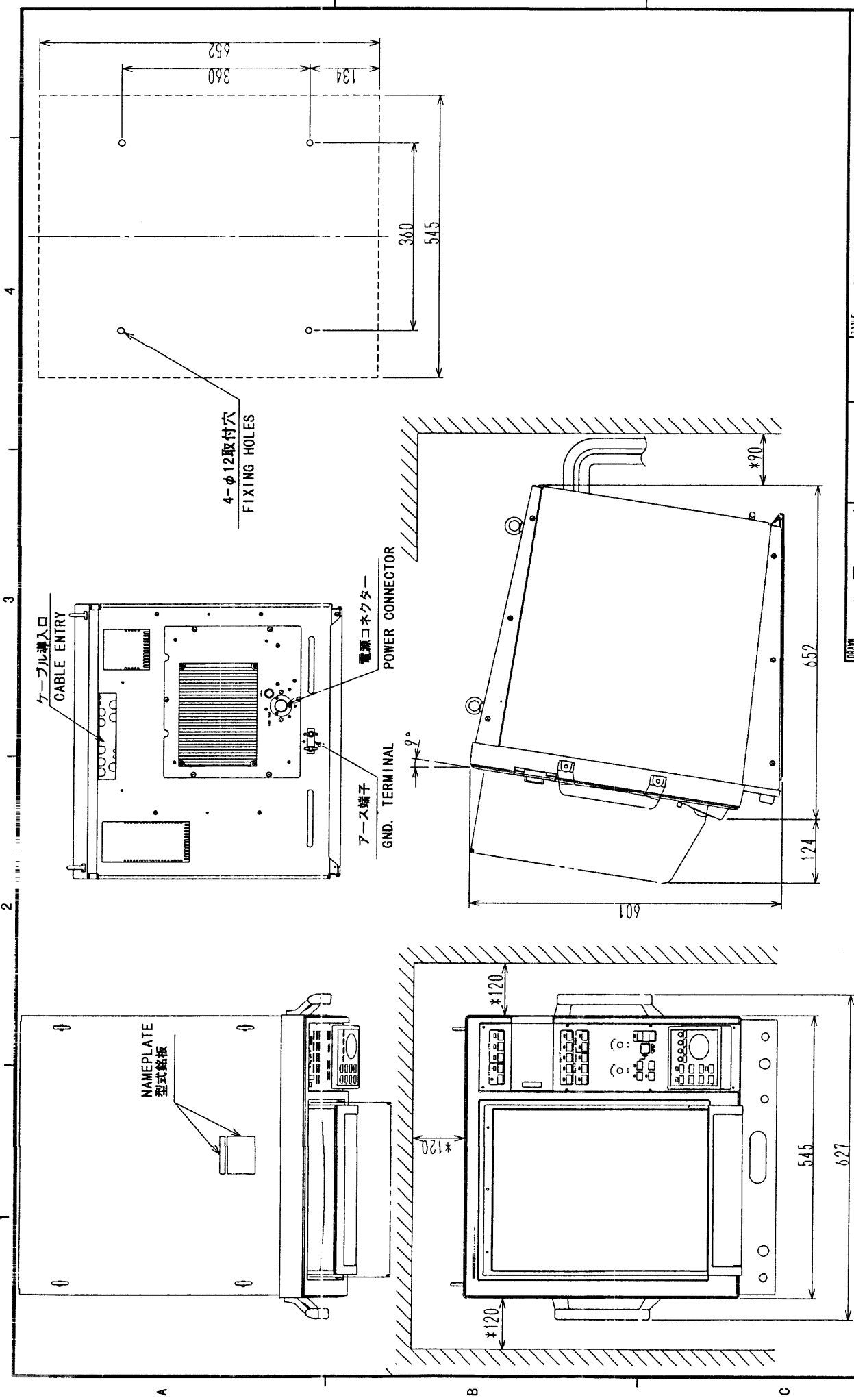

DRAWN 1987.10.16 DESIGNED 1988.01.19 APPROVED 1988.01.19 SCALE	CSH-84 CSH-2400 CSH-2401 CSH-24	TITLE 名 称 外 寸 図	CSH-2400 指示装置
DATE 1/10	ISSUE NO. 66	NAME DISP. UNIT	OUTLINE DIAGRAM
Dwg. No. C1310-G01-A		10-064-1000-G2	

注記
1) *印寸法は最小サービス空間寸法とする。
NOTE
1. *: RECOMMENDED SERVICE CLEARANCE DIMENSION.

FURUNO ELECTRIC CO., LTD.

表 1 TABLE 1

寸法区分 (mm) DIMENSIONS	公差 (mm) TOLERANCE
L ≤ 50	±1.5
50 < L ≤ 100	±2.5
100 < L ≤ 500	±3

注 記

- 1) 指定外の寸法公差は表1による。
- 2) #印寸法は最小サービス空間寸法とする。
- 3) 取付用ネジは+トラスタックピンネジ6×2.0を使用のこと。
- 4) 装備ケーブルはサービス時、本体を前方に十分引き出せるよう余裕を持たせること。

NOTE

1. TABLE 1 INDICATES TOLERANCE OF DIMENSIONS WHICH IS NOT SPECIFIED.
2. # MINIMUM SERVICE CLEARANCE.
3. USE SELF-TAPPING SCREWS 6x2.0 FOR FIXING THE UNIT.
4. LEAVE ENOUGH SLACK IN CABLING SO UNIT CAN BE DRAWN FORWARD WITHOUT DISCONNECTING CABLING.

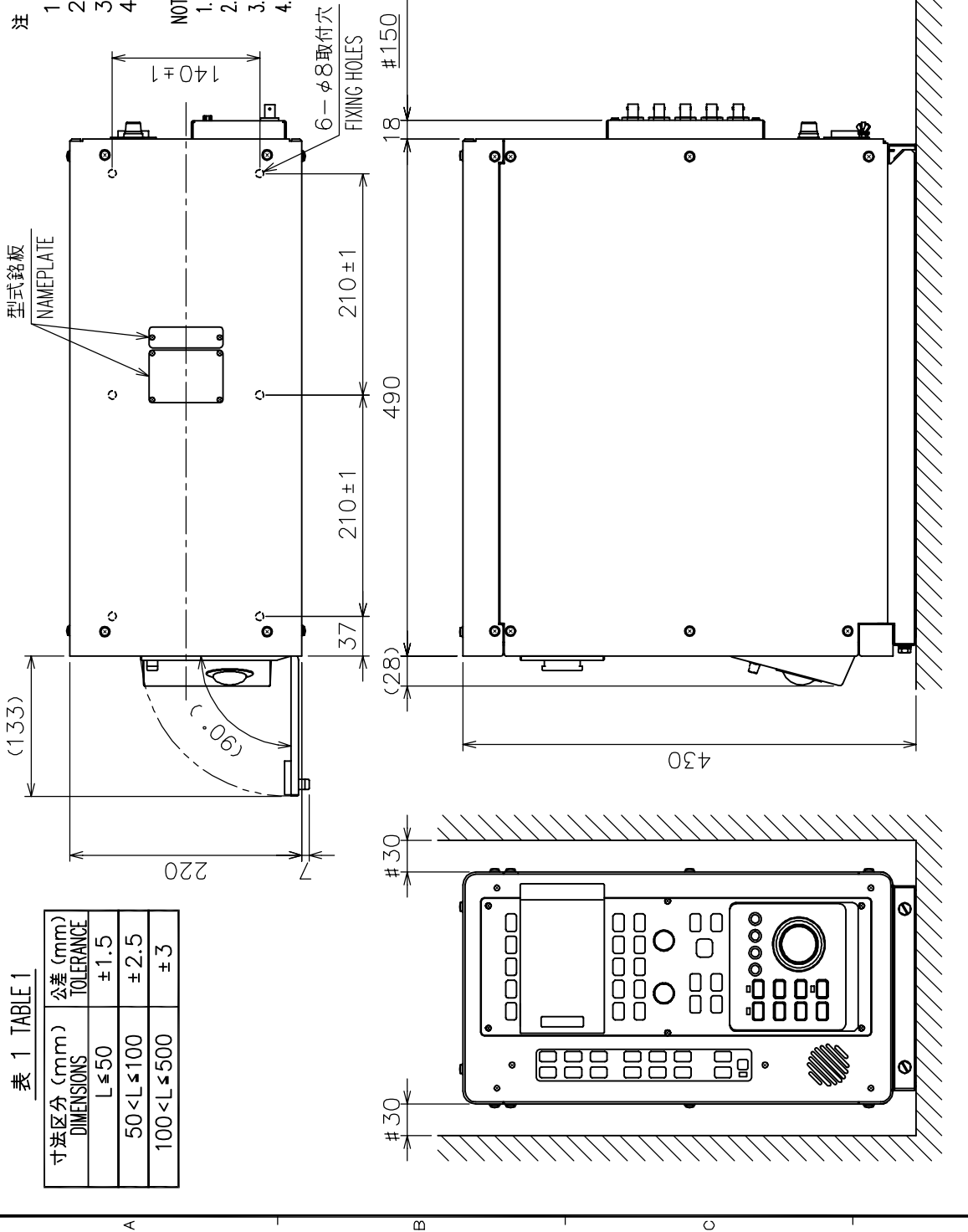

DRAWN	Jan. 14, '05	E. MIYOSHI	TITLE	CSH-235/235F/235K/835/585/535/735
CHECKED		TAKAHASHI, T.	名称	操作制御部
APPROVED		Y. Hatai	外寸図	
SCALE	1/6	MASS ±10%	NAME	PROCESSOR UNIT
DWG. No.	C1304-G01-A	10-085-100G-2	OUTLINE DRAWING	

表 1 TABLE 1

寸法区分 (mm) DIMENSION	公差 (mm) TOLERANCE
$0 < L \leq 50$	± 1.5
$50 < L \leq 100$	± 2.5
$100 < L \leq 500$	± 3

A

B

C

D

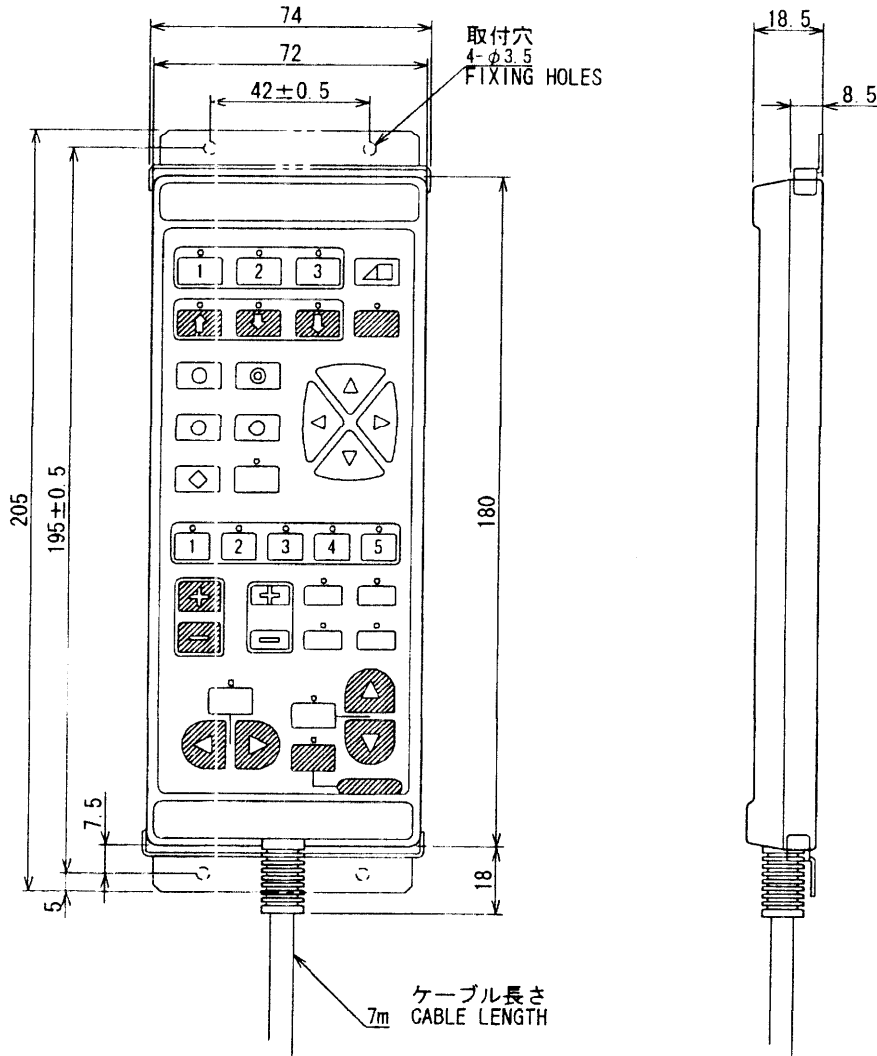

注記

1) 指定なき寸法公差は表 1 による。

NOTE

1. TABLE 1 INDICATES TOLERANCE OF DIMENSIONS.

DRAWN Dec. 26 '00 T. YAMASAKI		TITLE CSH-116/135
CHECKED Dec 27 '00 Y. K.		名称 リモート箱
APPROVED Dec 27 '00 Y. K.	CSH-53/33/73/58 CSH-21/22/23/23F	外寸図
SCALE 1/2	MASS 1.5 kg	NAME REMOTE CONTROL BOX
DWG. No. C1286-G02-D		OUTLINE DRAWING

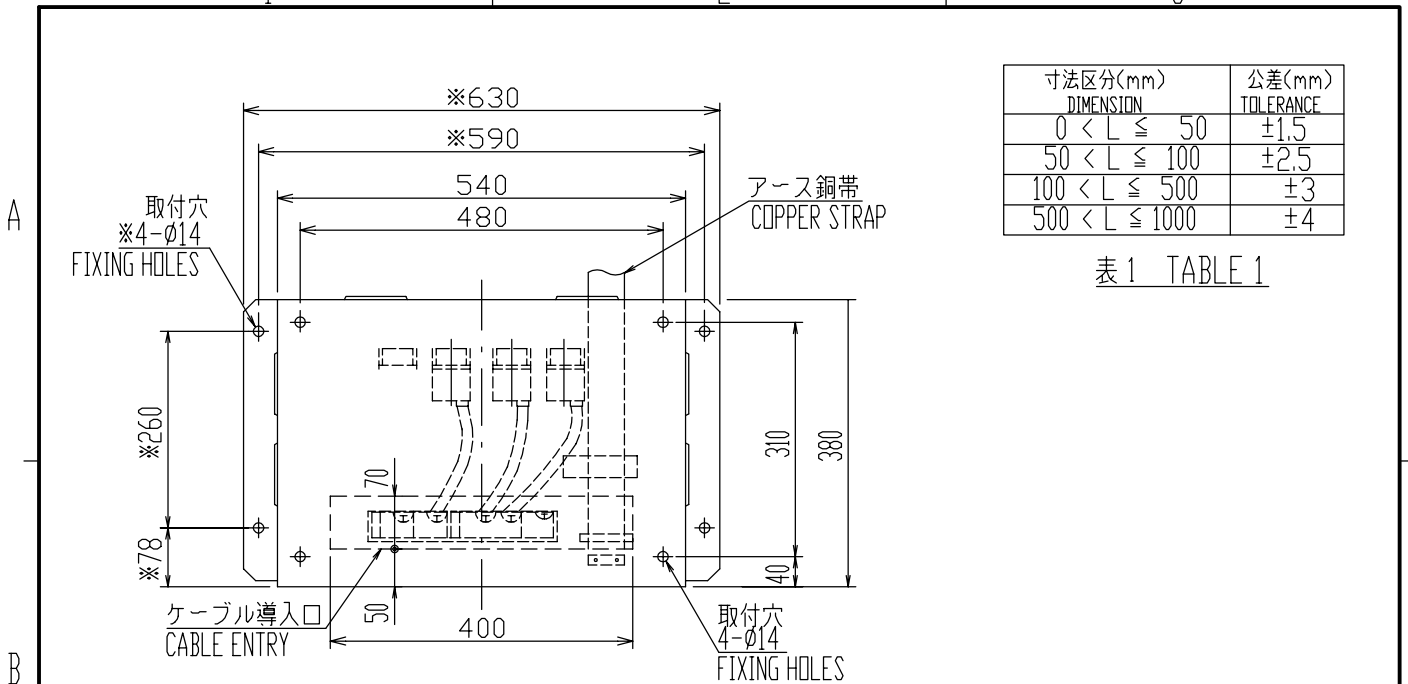

寸法区分(mm) DIMENSION	公差(mm) TOLERANCE
0 < L ≤ 50	±1.5
50 < L ≤ 100	±2.5
100 < L ≤ 500	±3
500 < L ≤ 1000	±4

表1 TABLE 1

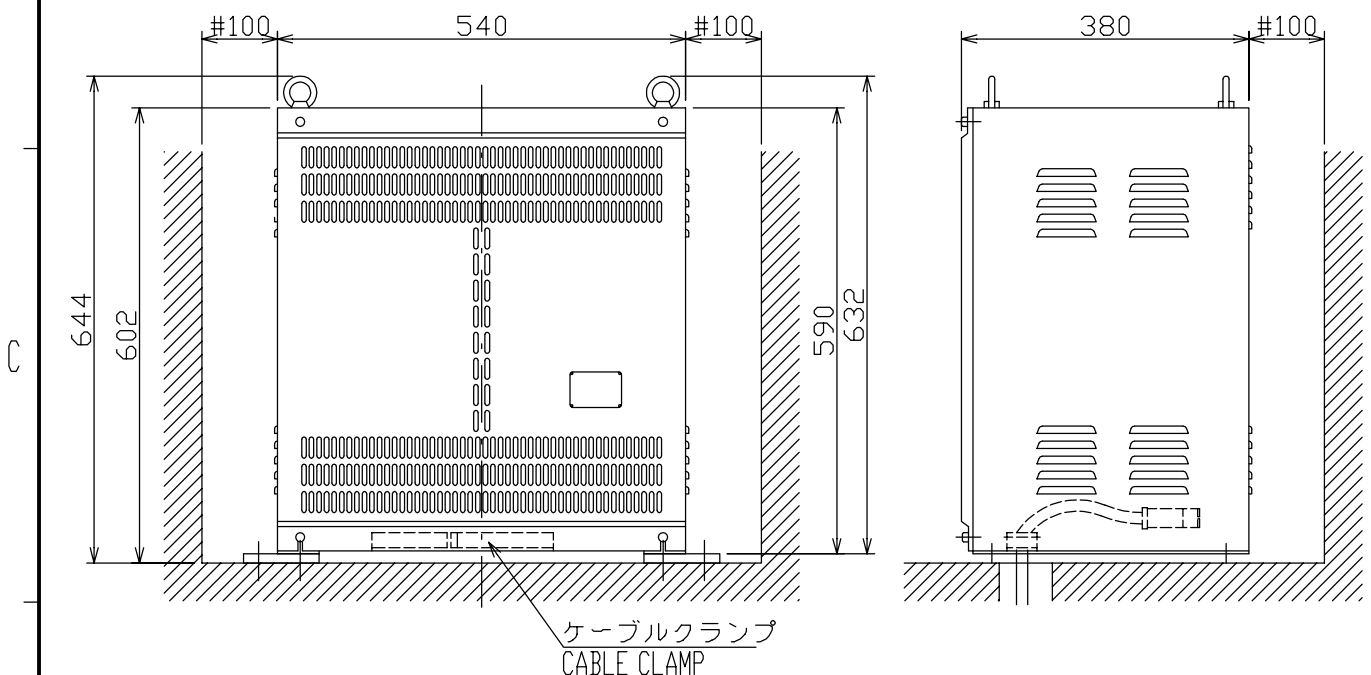

注記

- 1) 指定なき寸法公差は表1による。
- 2) #：推奨するサービス空間寸法。
- 3) ※印は外足取付時の寸法（取外し可）。

NOTES

1. TABLE 1 INDICATES TOLERANCE OF DIMENSIONS.
2. #: RECOMMENDED SERVICE CLEARANCE.
3. *: MOUNTING DIMENSIONS OF OUTSIDE LEGS (REMOVABLE).

型式 MODEL	質量 MASS (kg±10%)
CSH-310	96
CSH-810	82

表2 TABLE 2

DRAWN Oct. 17 '03 T.YAMASAKI	TITLE CSH-310/K,CSH-810
CHECKED Oct. 20 '03 T.MATSUGUCHI	名称 送振装置
APPROVED Oct. 31 '03 <i>Matsuguchi</i>	外寸図
SCALE 1/10 MASS 表2参照 TABLE 2	NAME TRANSMITTER UNIT
DWGNo. C1257-018-G	OUTLINE DRAWING

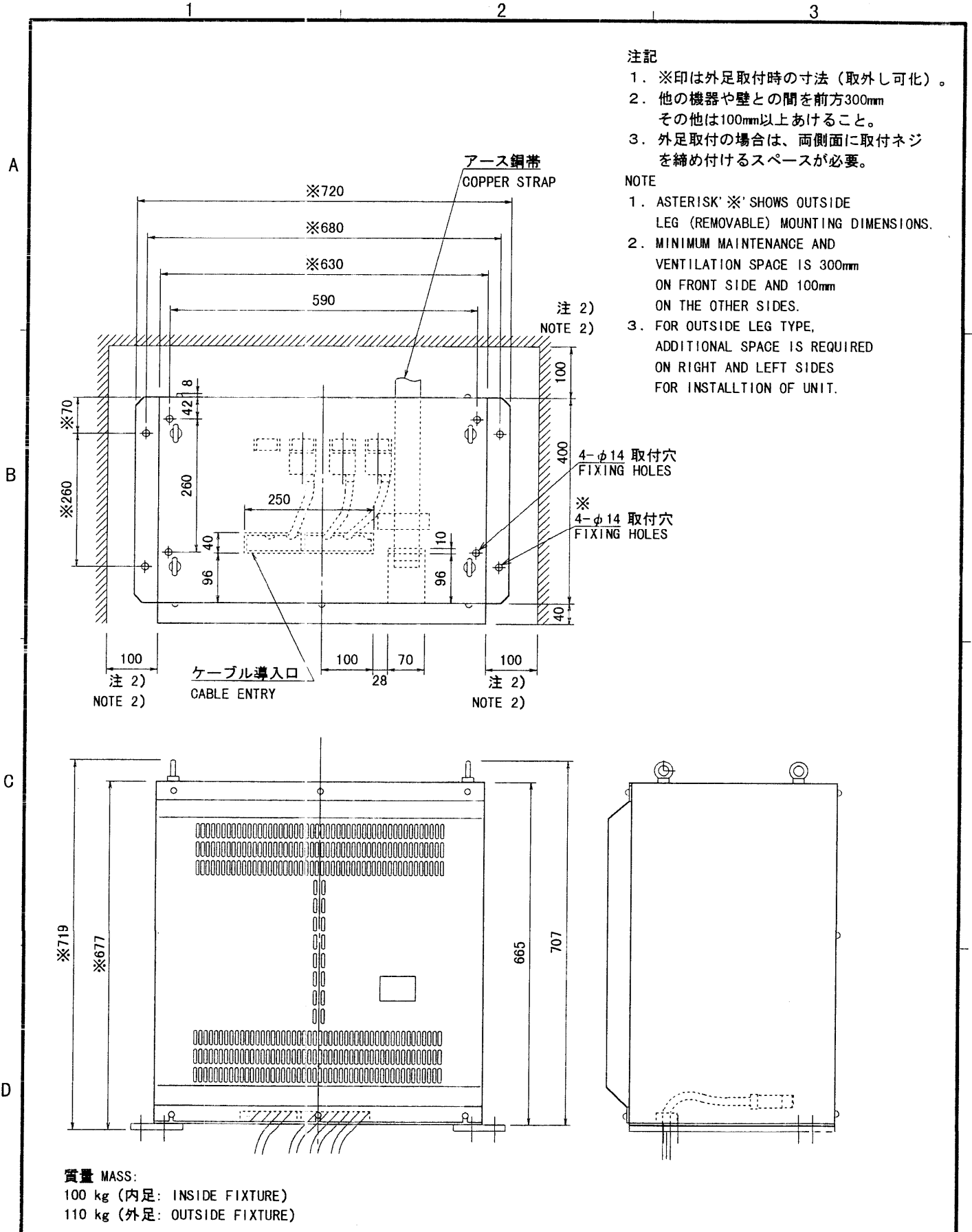

DRAWN <i>June 26 '00 T.YAC/ASAC</i>		TITLE GSH-310S/F II	
CHECKED <i>June 26 '00 Y. Kim</i>		名称 送振装置	
APPROVED <i>June 26 '00 Y. Kim</i>		外寸図	
SCALE 1/1	MASS kg	NAME TRANSMITTER UNIT	
DWG. No. G1272-G02- D		OUTLINE DRAWING	

FURUNO

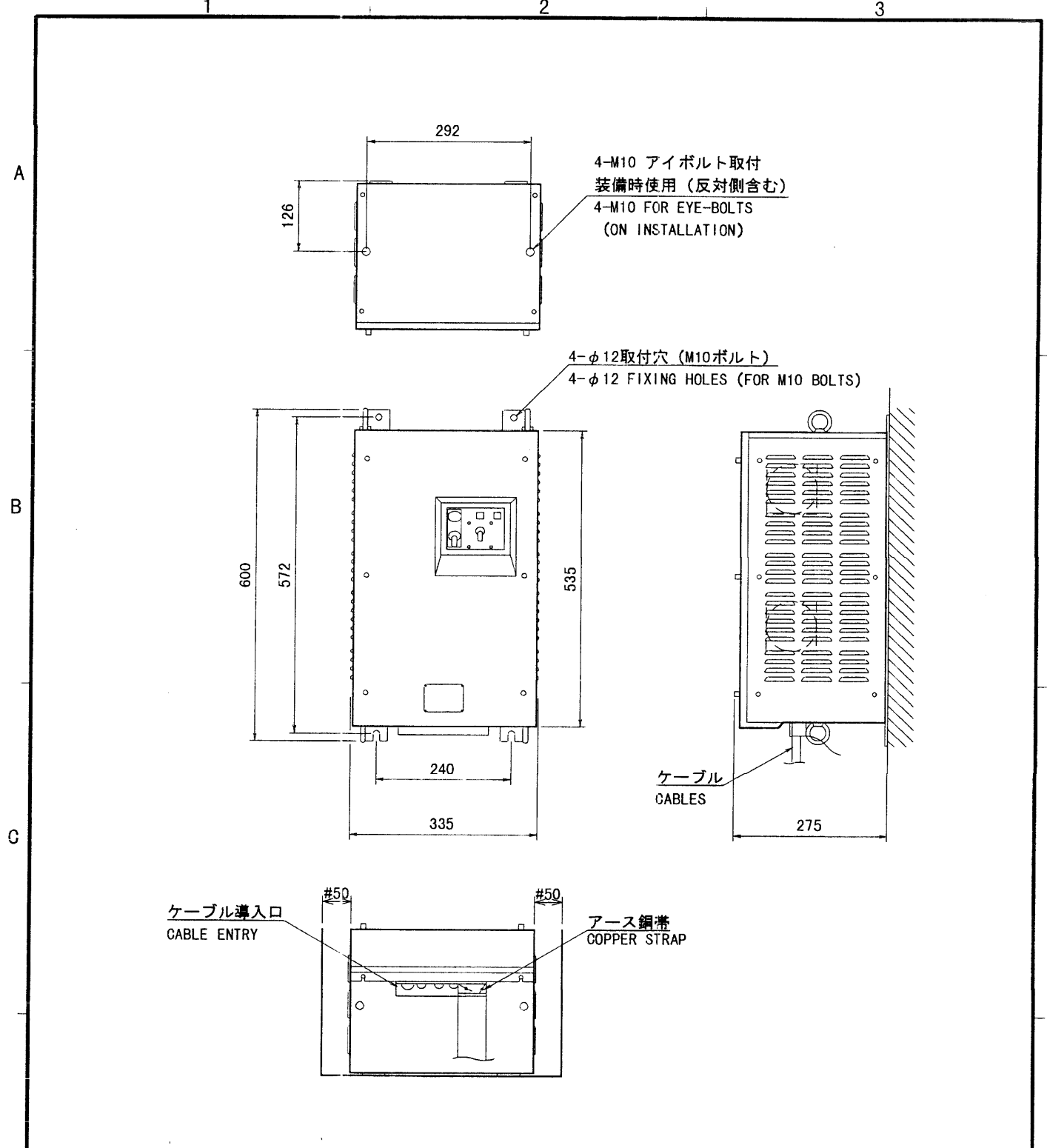

: 推奨するサービス空間寸法。
 #: RECOMMENDED SERVICE CLEARANCE.

DRAWN June 26 '00 T. YAMASAKI		TITLE CSH-380A/B, CSH-380S	
CHECKED June 26 '00 Y. Kim		名称 電源装置	
APPROVED June 26 '00 Y. Kim		外寸図	
SCALE 1/10	MASS 56 kg	NAME POWER UNIT	
DWG. No. C1257-065- D		OUTLINE DRAWING	

FURUNO ELECTRIC CO., LTD.

FURUNO

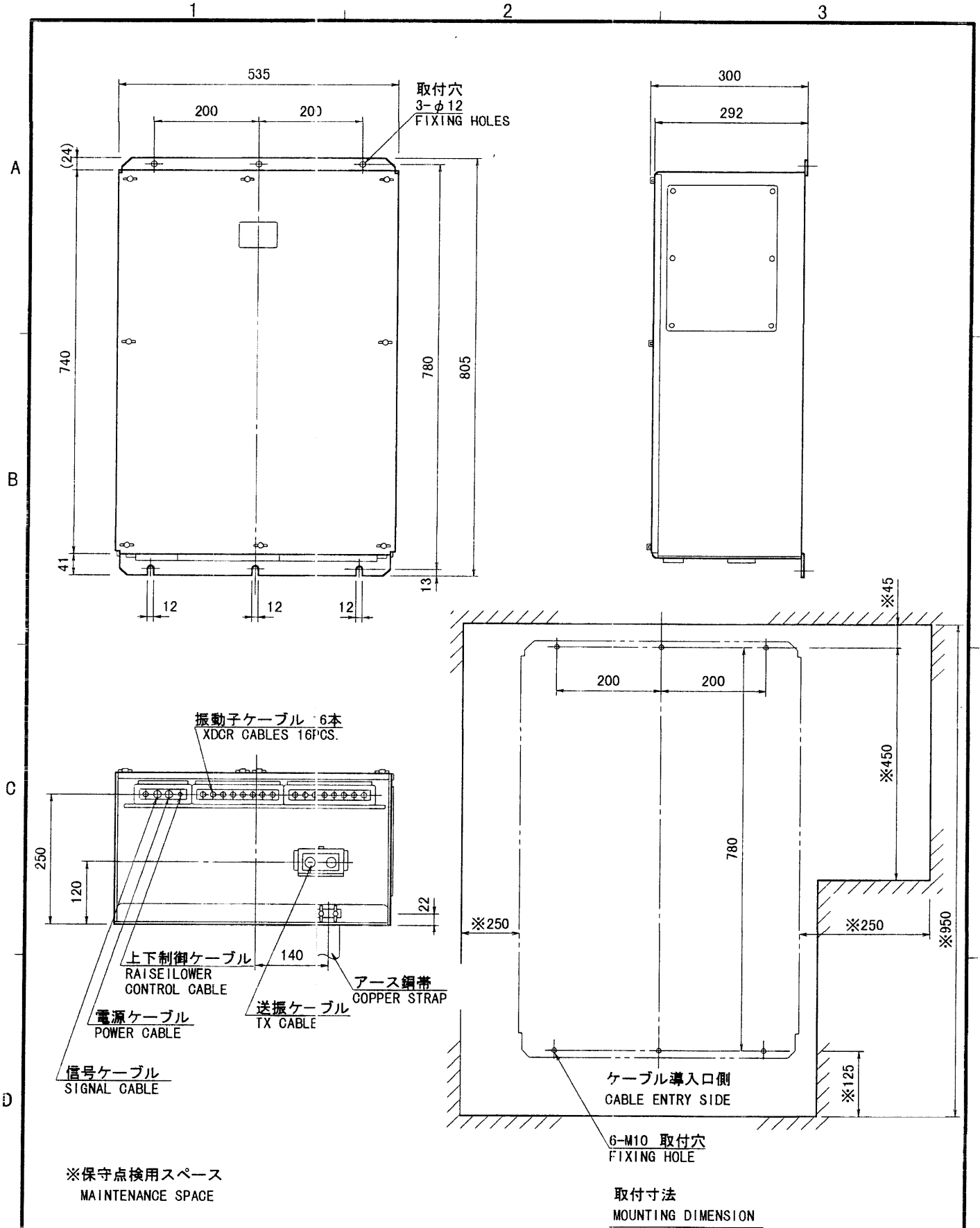

DRAWN June 26 '00 T. YAMASAKI		TITLE CSH-220A/K/F II, CSH-220S	
CHECKED June 26 '00 Y. KIMURA		名称 受信装置	
APPROVED June 26 '00 Y. KIMURA		OTHERS CSH-21/22	
SCALE 1/10	MASS 47 kg	外寸図	
DWG. No. C1257-013-F		NAME RECEIVER UNIT	
OUTLINE DRAWING			

寸法区分 (mm) DIMENSION	公差 (mm) TOLERANCE
$L \leq 50$	± 1.5
$50 < L \leq 100$	± 2.5
$100 < L \leq 500$	± 3

表 1 TABLE 1

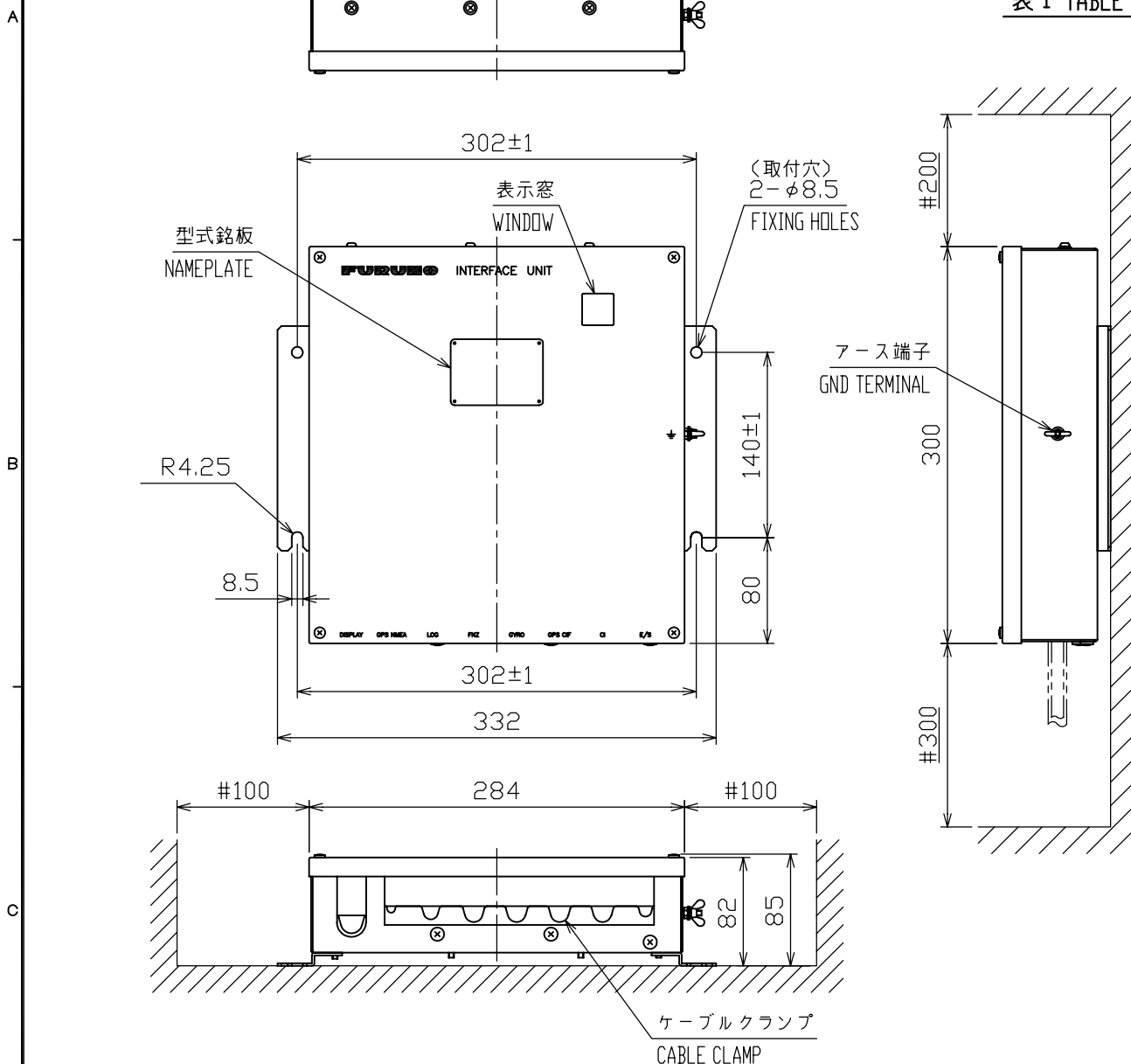

- 注 記 1) #印寸法は最小サービス空間寸法とする。
 2) 指定外の寸法公差は表 1 による。
 3) 取付用ネジは M8 ボルト、またはコーチボルト呼び径 8 を使用のこと。

- NOTE 1. #: RECOMMENDED SERVICE CLEARANCE.
 2. TABLE 1 INDICATES TOLERANCE OF DIMENSIONS.
 3. USE M8 BOLTS OR COACH SCREWS $\phi 8$ FOR FIXING THE UNIT.

DRAWN Dec. 10 '02 T.YAMASAKI	TITLE CS-120A
CHECKED Dec. 10 '02 Y.KIMURA	名称 インターフェイス
APPROVED Dec. 10 '02 <i>Y. Kimura</i>	外寸図
SCALE 1/5 MASS 4.5 ±10% kg	NAME INTERFACE
DWG.No. C1310-G02-A	10-064-200G-0 OUTLINE DRAWING

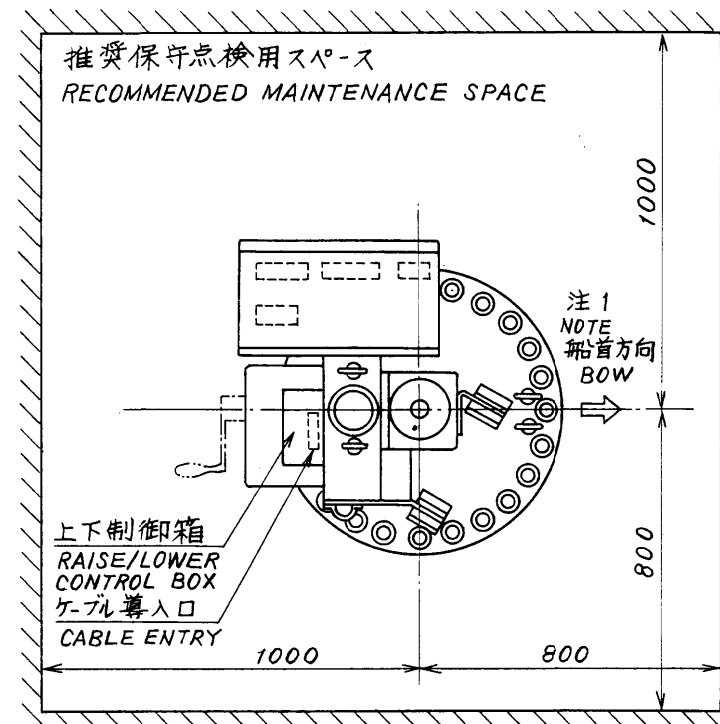
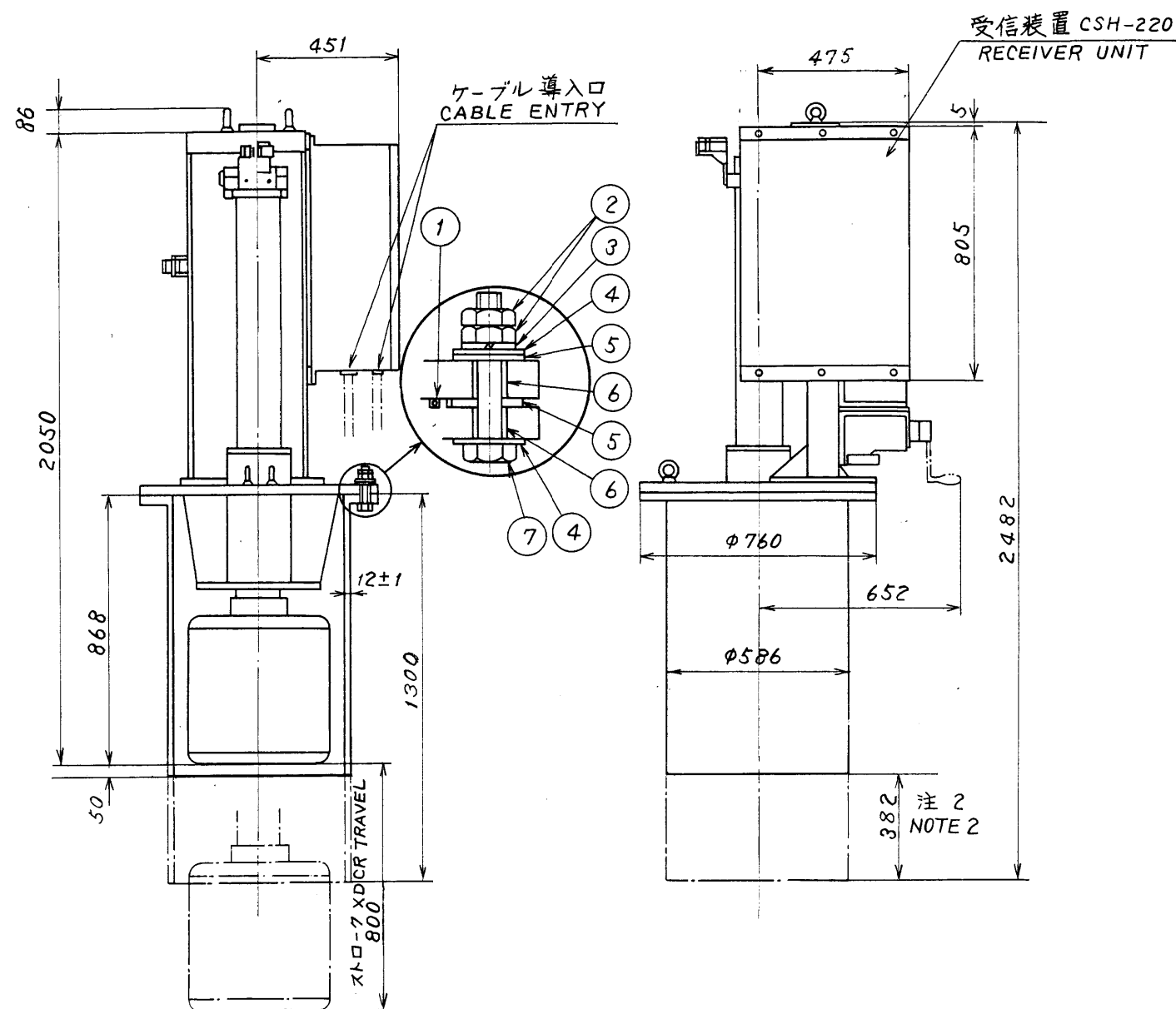

注記

- 1) 架台フランジ上の矢印を船首方向に一致させることができないときは、指示装置内で船首線を調整のこと。
- 2) 装備位置に応じて 382mm 以内で切断のこと。
- 3) オプションの送受波器を使用するときは、若干形状・寸法が異なります。

NOTE

1. HEADING ADJUSTMENT IS REQUIRED IN DISPLAY UNIT IF THE ARROW MARK ON GALLOWS FLANGE DOES NOT FACE SHIP'S BOW.
2. CUT THE TANK WITHIN 382 mm IN LENGTH ACCORDING TO INSTALLATION SITE.
3. THE DIMENSIONS OF TRANSDUCER MAY BE CHANGED SLIGHTLY WHEN AN OPTIONAL TRANSDUCER IS USED.

品番 ITEM	品名 NAME	材質 MATERIAL	数量 Q'TY	図番 DWG.NO.	摘要 REMARKS
7	六角ボルト HEX. BOLT	SUS304	13	M20×120	
6	絶縁パッキン(2) INSULATION PACKING(2)		37	MS-1000-68	
5	絶縁パッキン(1) INSULATION PACKING(1)		48	MS-1000-67	
4	平座金 FLAT WASHER	SUS304	37	MS-1000-69	
3	バネ座金 SPRING WASHER	SUS304	24	FOR M20	
2	六角ナット HEX. NUT	SUS304	48	M20	
1	Oリング O-RING		1	JISB2401 V585	

DRAWN 02/06/20 T. YAMASAKI	TYPE CSH-3080/21080
CHECKED 02/6/20 Y.K.	名称 上下装置(ストローク800mm)
APPROVED 02/6/20 Y.K.	外寸図
SCALE MASS	MODEL CSH-23/24
Dwg No. C1257-014-F	BLOCK No. NAME HULL UNIT (800mm TRAVEL)
	OUTLINE DRAWING

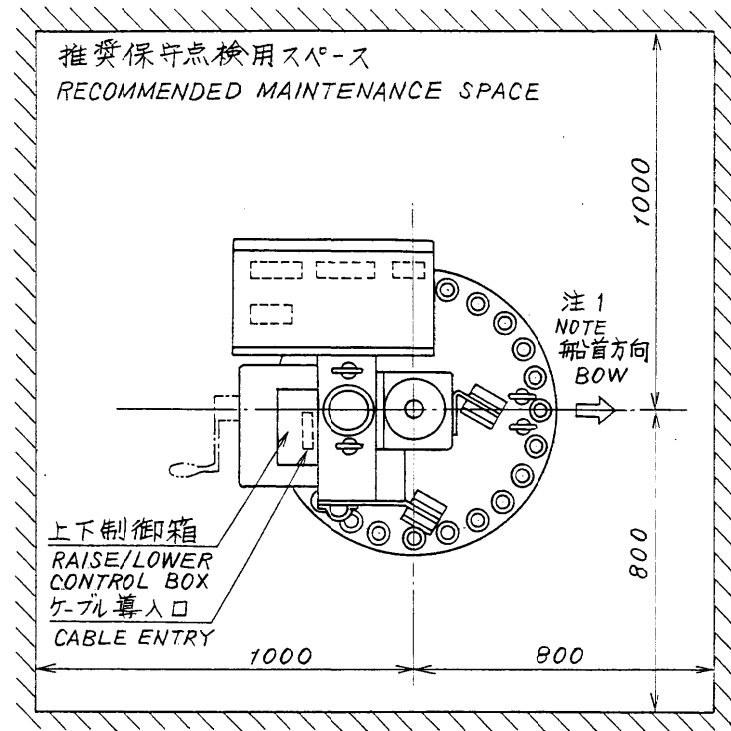
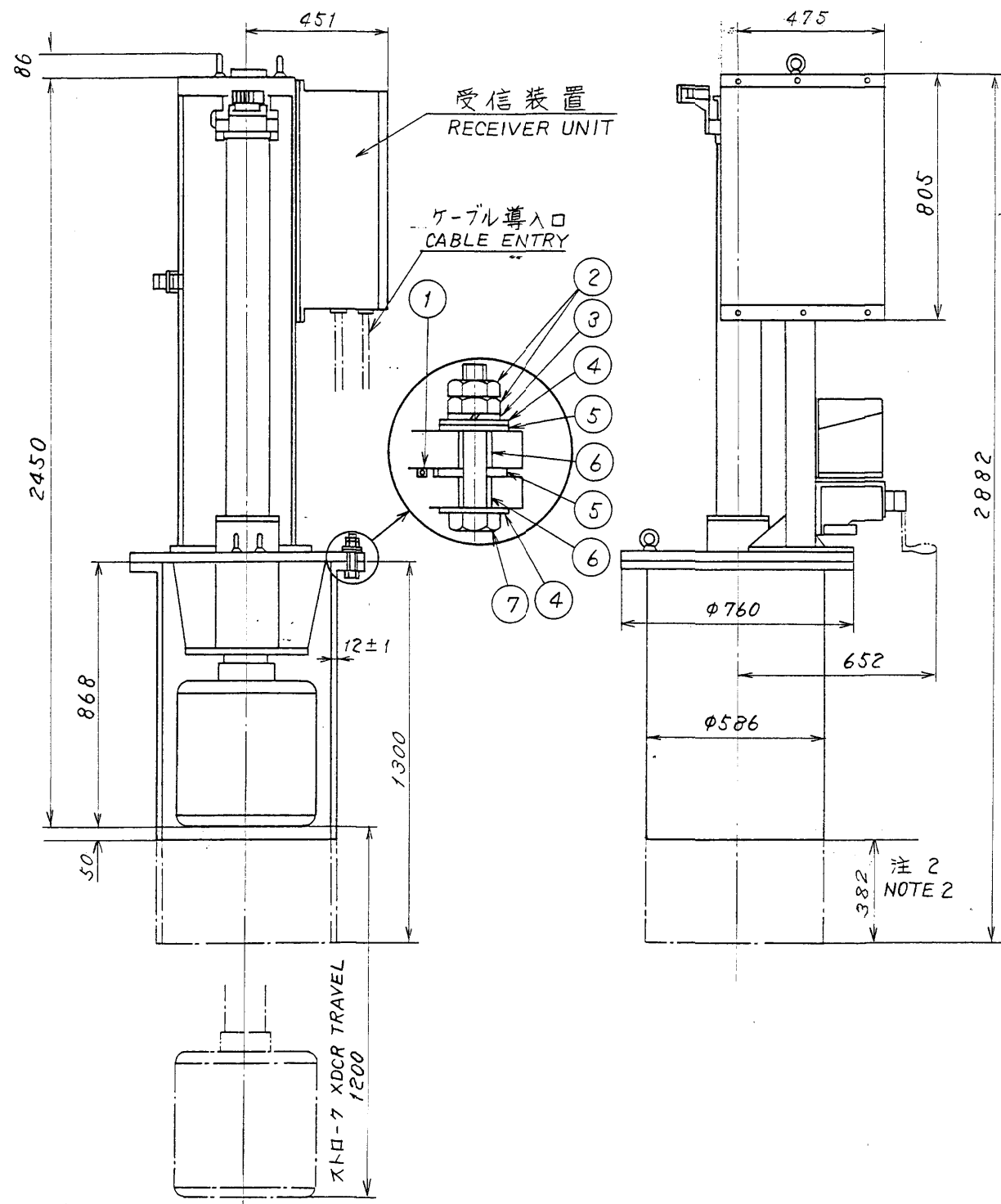

- 注記
- 1) 架台フランジ上の矢印を船首方向に一致させることができないときは、指示装置内で船首線を調整のこと。
 - 2) 装備位置に応じて 382mm 以内で切断のこと。
 - 3) オプションの送受波器を使用するときは、若干形状・寸法が異なります。

- NOTE
1. HEADING ADJUSTMENT IS REQUIRED IN DISPLAY UNIT IF THE ARROW MARK ON GALLIOWS FLANGE DOES NOT FACE SHIP'S BOW.
 2. CUT THE TANK WITHIN 382 mm IN LENGTH ACCORDING TO INSTALLATION SITE.
 3. THE DIMENSIONS OF TRANSDUCER MAY BE CHANGED SLIGHTLY WHEN AN OPTIONAL TRANSDUCER IS USED.

品番 ITEM	品名 NAME	材質 MATERIAL	数量 Q'TY	図番 DWG.NO.	摘要 REMARKS
7	六角ボルト HEX. BOLT	SUS304	13	M20×120	
6	絶縁パッキン(2) INSULATION PACKING(2)		37	MS-1000-68	
5	絶縁パッキン(1) INSULATION PACKING(1)		48	MS-1000-67	
4	平座金 FLAT WASHER	SUS304	37	MS-1000-69	
3	バネ座金 SPRING WASHER	SUS304	24	FOR M20	
2	六角ナット HEX. NUT	SUS304	48	M20	
1	Oリング O-RING		1	JISB2401 V585	

DRAWN 02/06/20 T. YAMASAKI	TYPE CSH-3120/21120
CHECKED 02/6/20 Y. K.	名称 上下装置(ストローク1200mm)
APPROVED 02/6/20 Y. K.	外寸図
SCALE MASS	MODEL BLOCK No.
Dwg No. C1257-015- G	NAME HULL UNIT (1200mm TRAVEL)
	OUTLINE DRAWING

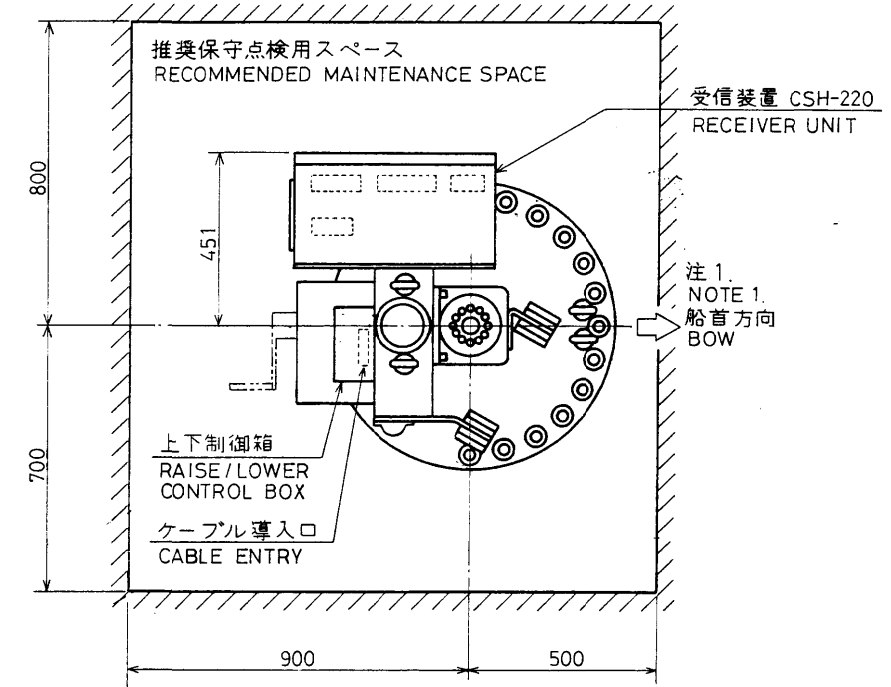
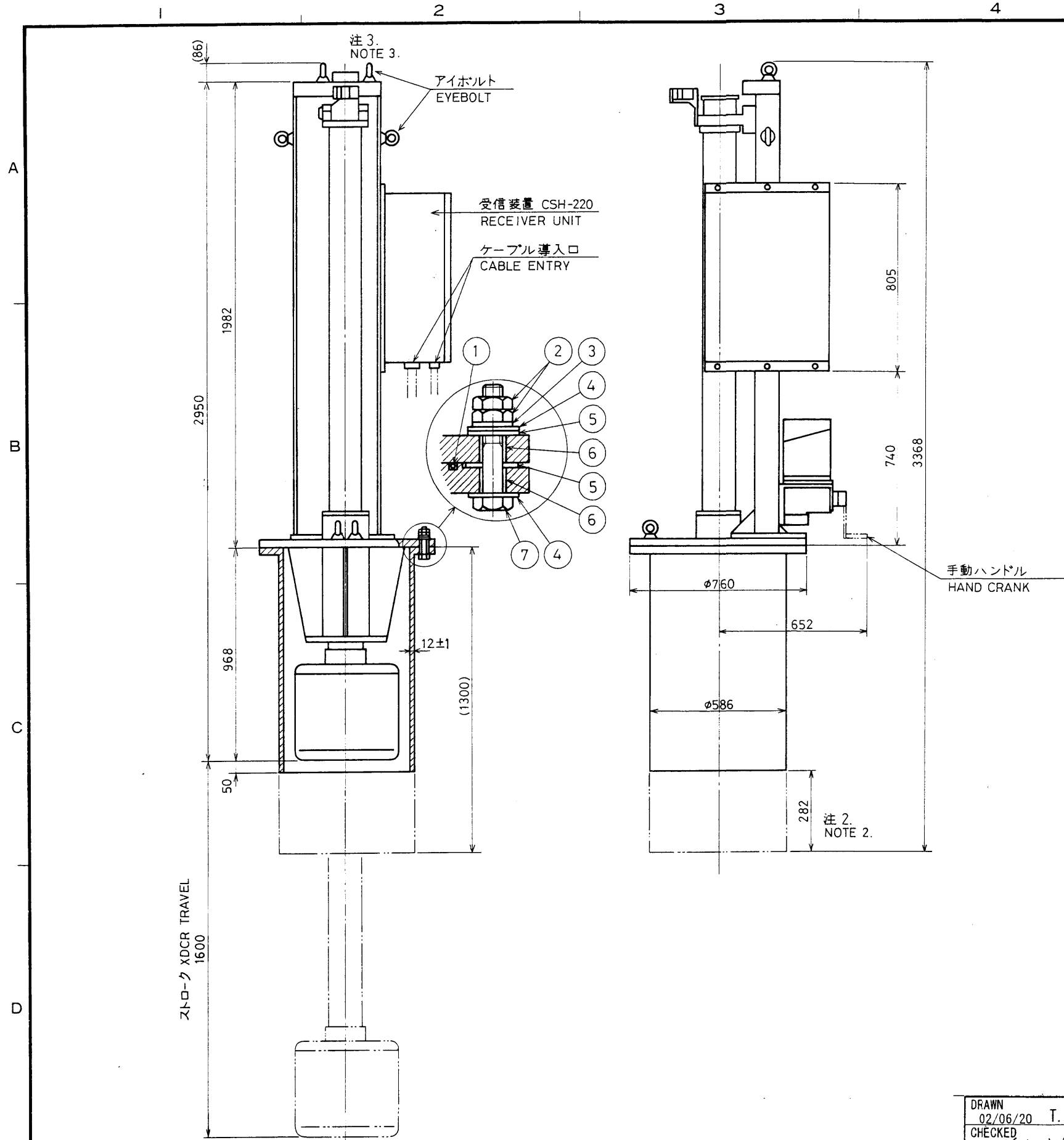

- 注記
- 1) 架台フランジ上の矢印を船首方向に一致させることができないときは、指示装置内で船首線を調整のこと。
 - 2) 装備位置に応じて 282mm 以内で切断のこと。
 - 3) 架台最上部にはアイボルトを利用して必ず防振用のステーを張ること。
 - 4) オプションの送受波器を使用するときは、若干形状・寸法が異なります。

- NOTE
1. HEADING ADJUSTMENT IS REQUIRED IN DISPLAY UNIT IF THE ARROW MARK ON GALLOWS FLANGE DOES NOT FACE SHIP'S BOW.
 2. CUT THE TANK WITHIN 282 mm IN LENGTH ACCORDING TO INSTALLATION SITE.
 3. UTILIZING EYE-NUTS ON TOP OF UNIT, EXTEND REINFORCEMENT STAYS TO SHIP'S HULL TO MINIMIZE VIBRATION OF UNIT.
 4. THE DIMENSIONS OF TRANSDUCER MAY BE CHANGED SLIGHTLY WHEN AN OPTIONAL TRANSDUCER IS USED.

品番 ITEM	品名 NAME	材質 MATERIAL	数量 Q'TY	図番 DWG. NO.	摘要 REMARKS
7	六角ボルト HEX. BOLT	SUS304	13	M20x120	
6	絶縁パッキン(2) INSULATION PACKING(2)	フェベリカ	37	MS-1000-68	
5	絶縁パッキン(1) INSULATION PACKING(1)	フェベリカ	48	MS-1000-67	
4	平座金 FLAT WASHER	SUS304	37	MS-1000-69	
3	バネ座金 SPRING WASHER	SUS304	24	FOR M20	
2	六角ナット HEX. NUT	SUS304	48	M20	
1	O-リング O-RING		1	JIS B 2401 V585	

DRAWN 02/06/20 T. YAMASAKI	TYPE CSH-3160/21160
CHECKED 02/06/20 Y.K.	名称 上下装置 (ストローク1600mm)
APPROVED 02/06/20 Y.K.	外寸図
SCALE MASS	MODEL CSH-23/24
Dwg No. C1257-080- D	BLOCK No. NAME HULL UNIT (1600mm TRAVEL)
OUTLINE DRAWING	

FURUNO

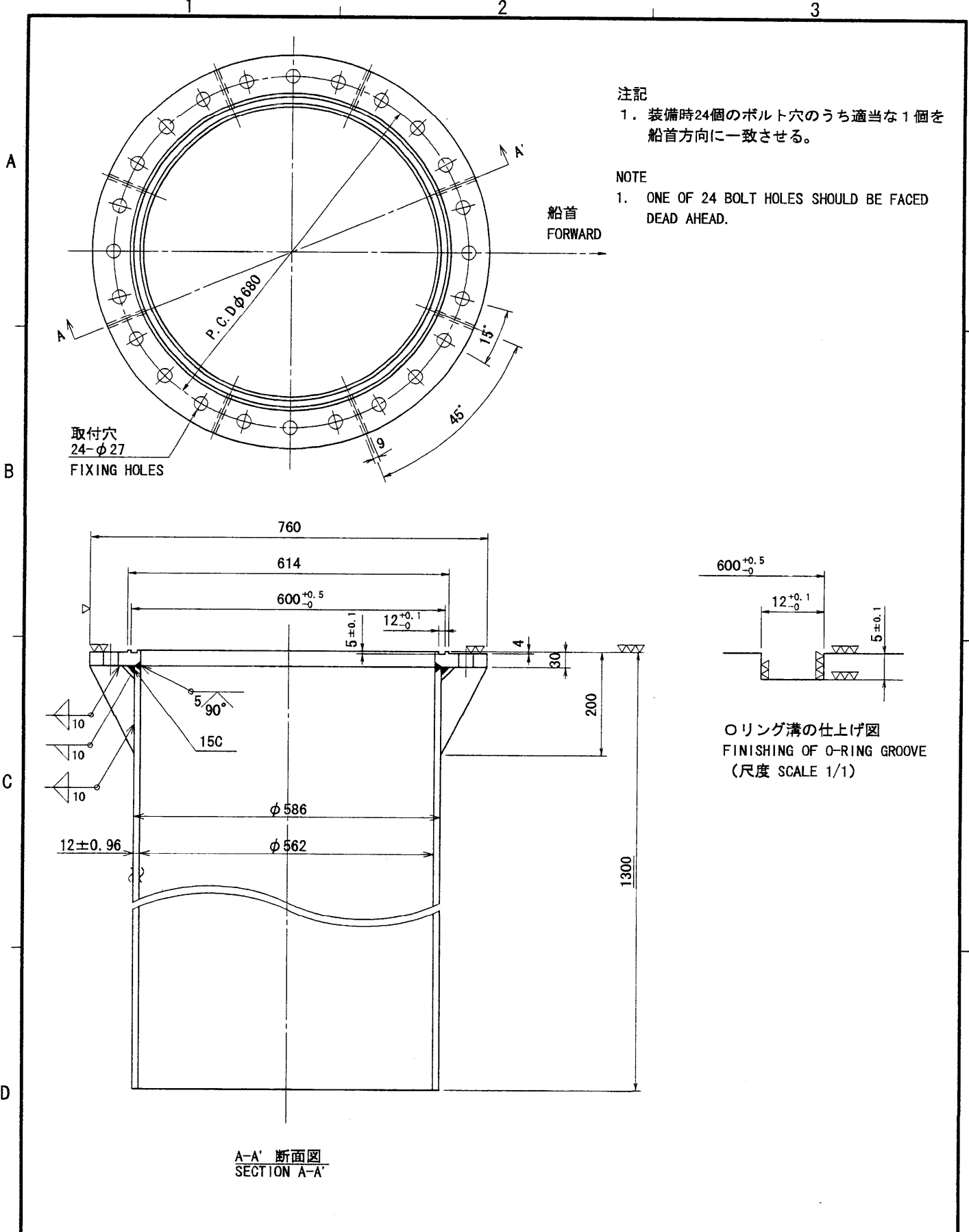

注記

1. 装備時24個のボルト穴のうち適当な1個を船首方向に一致させる。

NOTE

1. ONE OF 24 BOLT HOLES SHOULD BE FACED DEAD AHEAD.

A-A' 断面図
SECTION A-A'

○リング溝の仕上げ図
FINISHING OF O-RING GROOVE
(尺度 SCALE 1/1)

DRAWN Feb. 19 '01 T. YAMASAKI		TITLE	
CHECKED Feb 19 '01 Y. King		名称 格納タンク	
APPROVED Feb 26 '01 S. Johnson		FSV-24 CSH SERIES	
SCALE 1/10	MASS 258.5 kg	NAME RETRACTION TANK	
DWG. No. C1257-074- C		OUTLINE DRAWING	

(A) キール上(突出) ON KEEL (PROJECTED)

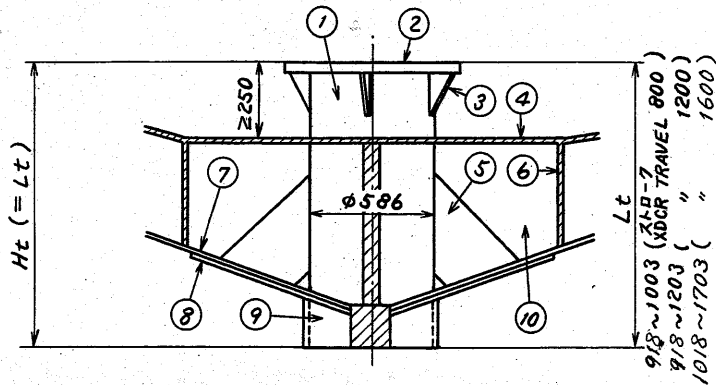

(B) キール横(突出) OFF KEEL (PROJECTED)

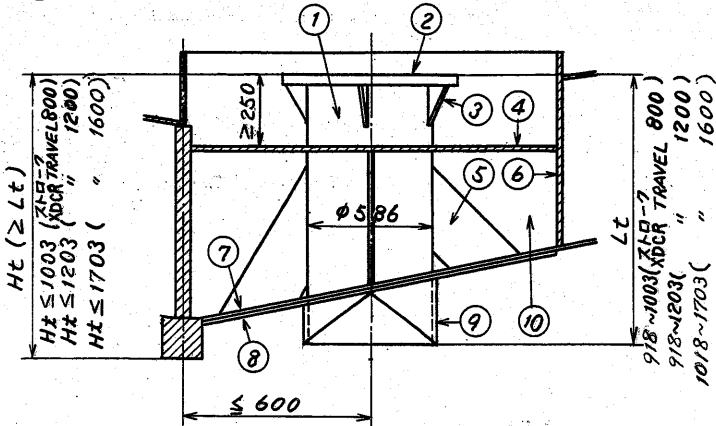

(C) キール横(非突出) OFF KEEL (NOT PROJECTED)

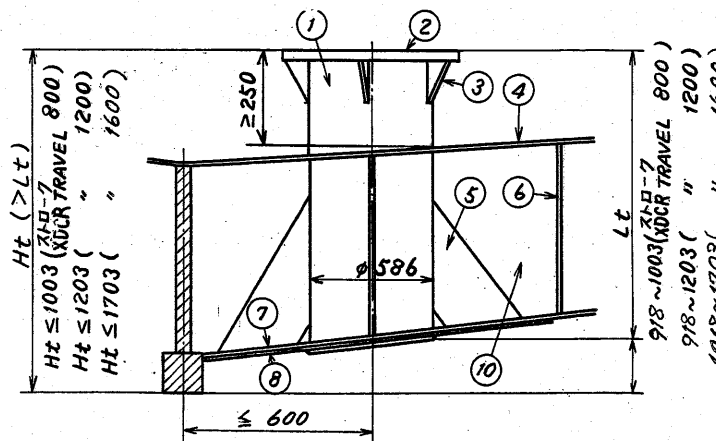

(D) 整流覆 FAIRING PLATE

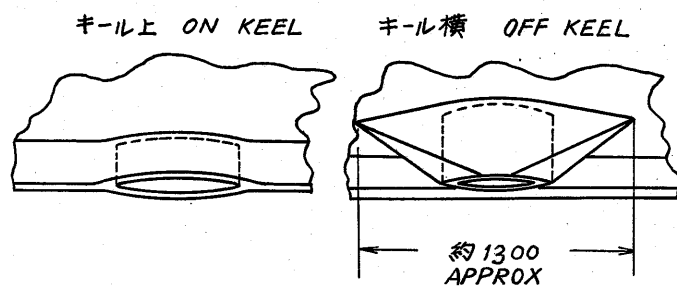

準備手順

- 船底板及び二重船底板にφ586の穴を明ける。
- 次の事に注意して格納タンクを船底板に連続スミ肉溶接する。
* タンクのフランジ面が標準走航時に水平になる事。
* フランジ面のボルト穴の中心が船首方向になる事。
* 送受波器を突出させた時に送受信ビームがキールで遮られないように、フランジ面のキールより高さ"Ht"を図示の範囲内にする事。
* タンク下端がキールより下に出ないようにタンクの長さ"Lt"は"Ht"より短くする。且つ、送受波器がタンク下端より出ないように図示の範囲内にする。(標準支給長1300mm)
- 格納タンクの周囲に外径φ1300以上のダブリング(8)を取り付ける。又、突出装備(A)(B)の場合には整流覆(9)(D図)を取り付ける。ダブリングと整流覆には、船底板と同じ材質、肉厚のものを使用する事。
- タンク周囲に油槽がある場合には、隔壁(6)をめぐらせ、コファダム(10)を設ける事。
- タンク周囲4ヶ所以上に補強板(5)を溶接する。
- 上下装置本体を格納タンクにボルト締めるのに必要なスペースとして、フランジ面の位置が二重船底板より250mm以上離す。二重船底が高い船には(B)図の方法で二重船底板を下げ、スペースを確保すること。

INSTALLATION METHOD OF RETRACTION TANK

- Cut out φ 586 hole on hull and inner hull plate.
- Install tank to hull plate with fillet welding taking the following points into account.
* Flange face is exactly horizontal at normal Ship's trim.
* One of 24 bolt holes on flange is faced dead ahead.
* Allow height of flange face from keel bottom "Ht" mentioned in the drawings, otherwise transducer beam is blocked by the keel when transducer is fully lowered.
* Tank's length "Lt" should be less than "Ht". If not so, bottom end of tank is placed below keel level. "Lt" is also limited as shown in the drawings so that the transducer can be fully retracted in tank. (The tank is supplied with 1300mm long as standard.)
- Fit doubling plate (8) of outer dia. φ 1300 around the tank on hull plate. Fit fairing plate (9) referring to the drawing (D) for installation method (A) and (B). Use same material and thickness of doubling and fairing plate as hull plate.
- Provide cofferdam around the tank in order to isolate the tank from the oil tank.
- Install 4 pcs. of reinforcement plates between the tank and the hull plate.
- Allow clearance of more than 250mm below the flange face for easy bolting. Sink the inner hull plate as shown in the drawing (B) for high inner hull plate.

10	コファダム COFFERDAM				
9	整流覆 FAIRING PLATE				
8	ダブリング DOUBLING				
7	船底板 HULL PLATE				
6	油槽隔壁 BULKHEAD				
5	補強板 REINFORCEMENT PLATE				
4	二重船底板 INNER HULL PLATE				
3	補強リブ REINFORCEMENT RIB				
2	タンクフランジ TANK FLANGE				
1	格納タンク RETRACTION TANK				

CSH-20/21 SINGLE freq.

品番 ITEM	品名 NAME	材質 MATERIAL	数量 Q'TY	図番 DWG.NO.	摘要 REMARKS
承認 APPROVED	<i>[Signature]</i>	三角法 THIRD ANGLE PROJECTION		名称 TITLE 格納タンク装備要領図(鋼船) INSTALLATION METHOD OF RETRACTION TANK(STEEL HULL)	
検図 CHECKED	<i>[Signature]</i>	尺度 SCALE			
製図 DRAWN	<i>[Signature]</i>	重量 WEIGHT		図番 DWG.NO. C1257-082-C	

注) CSH-20S/20F/21Fでは 1200/1600ストロークのみ。

FOR 1300mm TANK

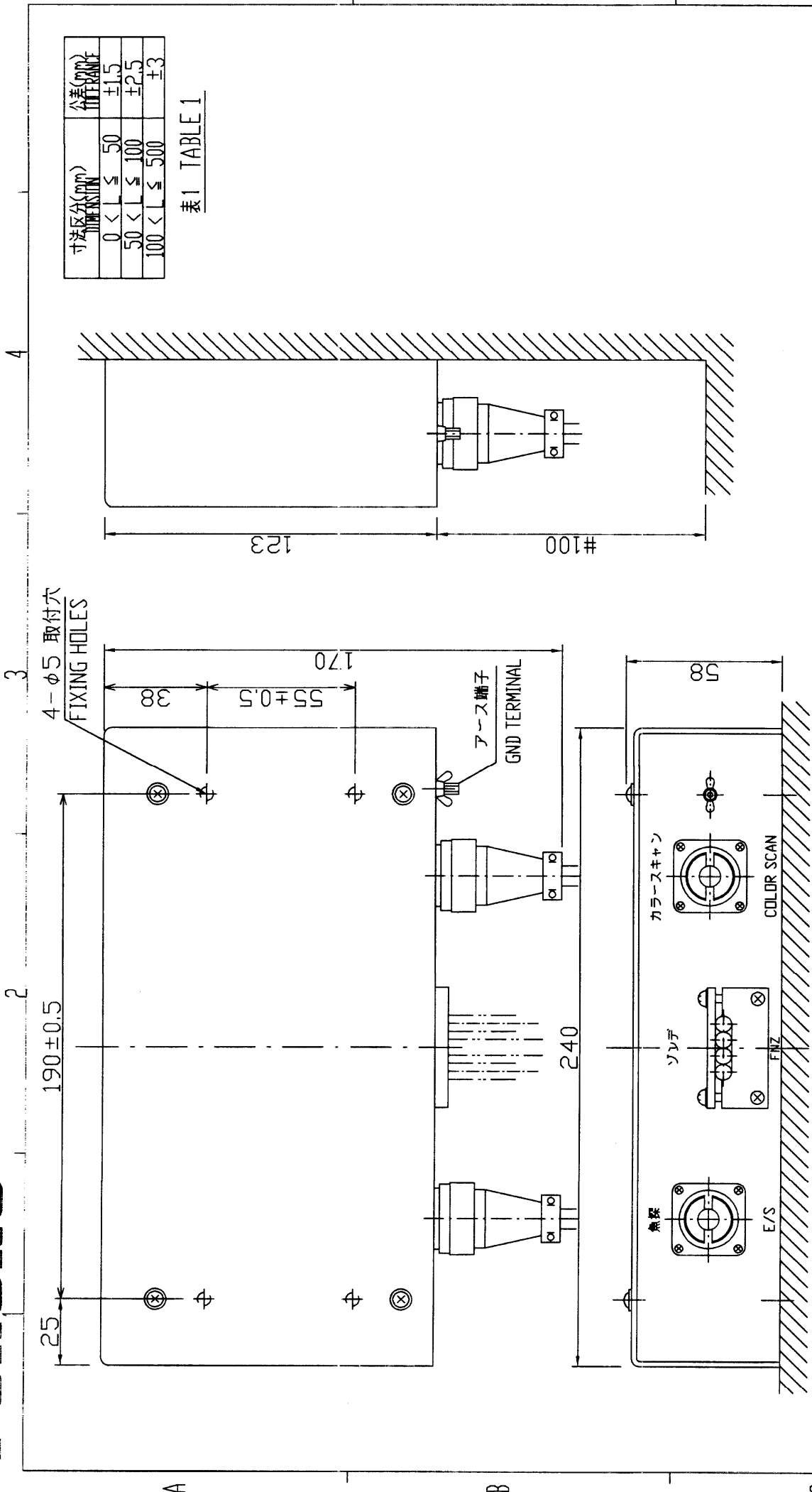

DRAWN JUL 11 '01 T. YAMASAKI	TITLE CS-170
CHECKED Tsub Y. K.	名称 ネットゾンデ接続箱
APPROVED Tsub Y. K.	外寸図
SCALE 1/2	NAME NET JOINT BOX
MASS 2 ±10% kg	OUTLINE DRAWING
DWG.No. C1233-007-D	

注記

- 1) 推梁する最小サービス空間寸法。
- 2) 指定なき寸法公差は表1による。

NOTE

1. # RECOMMENDED SERVICE CLEARANCE.
2. TABLE 1 INDICATES TOLERANCE OF DIMENSIONS.

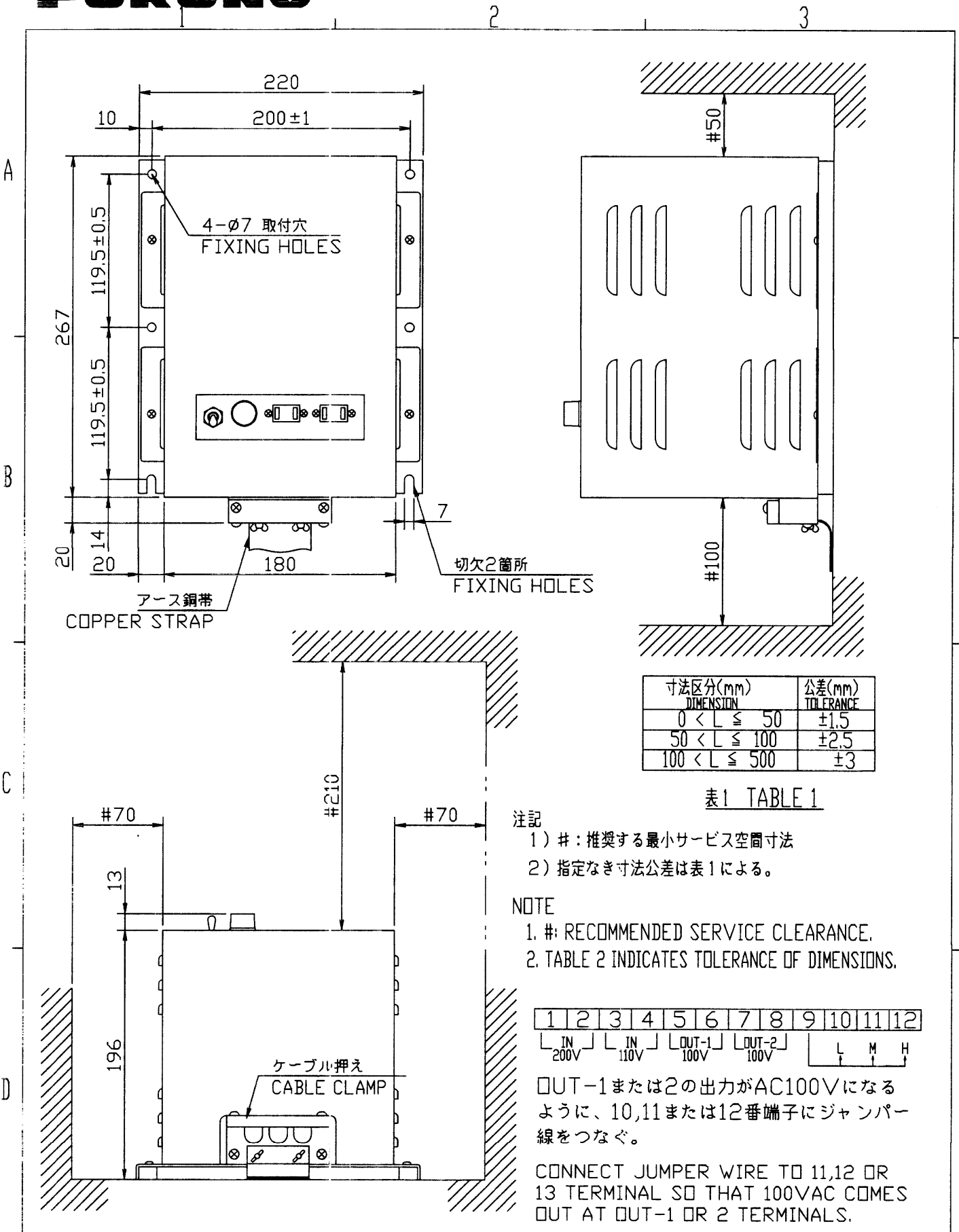

DRAWN	Jul. 16 '01 T.YAMASAKI	TITLE	PT-400
CHECKED	July 16 '01 Y.K.	名称	電圧変圧器
APPROVED	July 16 '01 Y.K.	CSH SERIES	外寸図
SCALE	1/4 MASS 22 ±10% kg	NAME	STEP-DOWN TRANSFORMER
DWG.No.	C0005-002-C		OUTLINE DRAWING

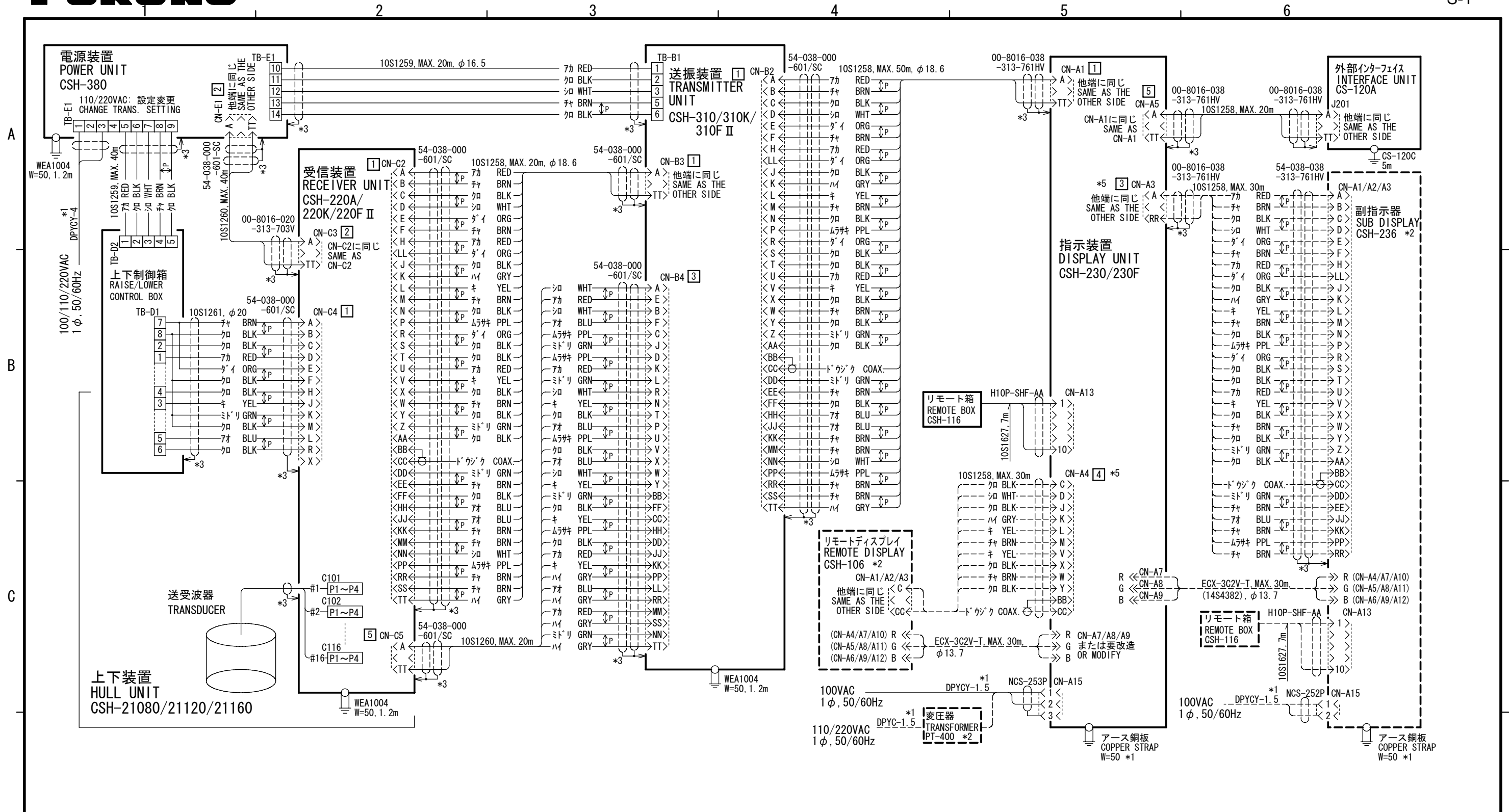

- 注記
- * 1) 造船所手配。
 - * 2) オプション。
 - * 3) ケーブルランプで接地。
 - * 4) □内の数値は誤挿入防止ピンA (太) 位置を示す。ガイドピンB (細) は全て“1”に設定。
 - * 5) 10S1258のRGBライン (FF/HH, MM/NN, SS/TT) は接続しないこと。画面の映像が歪む原因となることがあります。

- NOTE
- *1: SHIPYARD SUPPLY.
 - *2: OPTION.
 - *3: GROUND THRU CABLE CLAMP.
 - *4: NUMERAL IN □ SHOWS POSITION OF CONNECTOR GUIDE PIN[B]. GUIDE PIN[S] IS SET ALWAYS TO POSITION “1”.
 - *5: DO NOT CONNECT RGB LINE (CONNECTOR FF/HH, MM/NN, SS/TT) OF CABLE 10S1258. OR INTERFERENCE MAY APPEARS ON THE DISPLAY.

DRAWN Jun. 26 '06 T. YAMASAKI	TITLE CSH-23/23F/23K
CHECKED Jun. 26 '06 T. TAKENO	名称 カラスキャンニングソナー
APPROVED Jul. 24 '06 T. Matsuguchi	相互結線図
SCALE MASS kg	NAME COLOR SCANNING SONAR
DWG. No. C1304-C02- A	INTERCONNECTION DIAGRAM

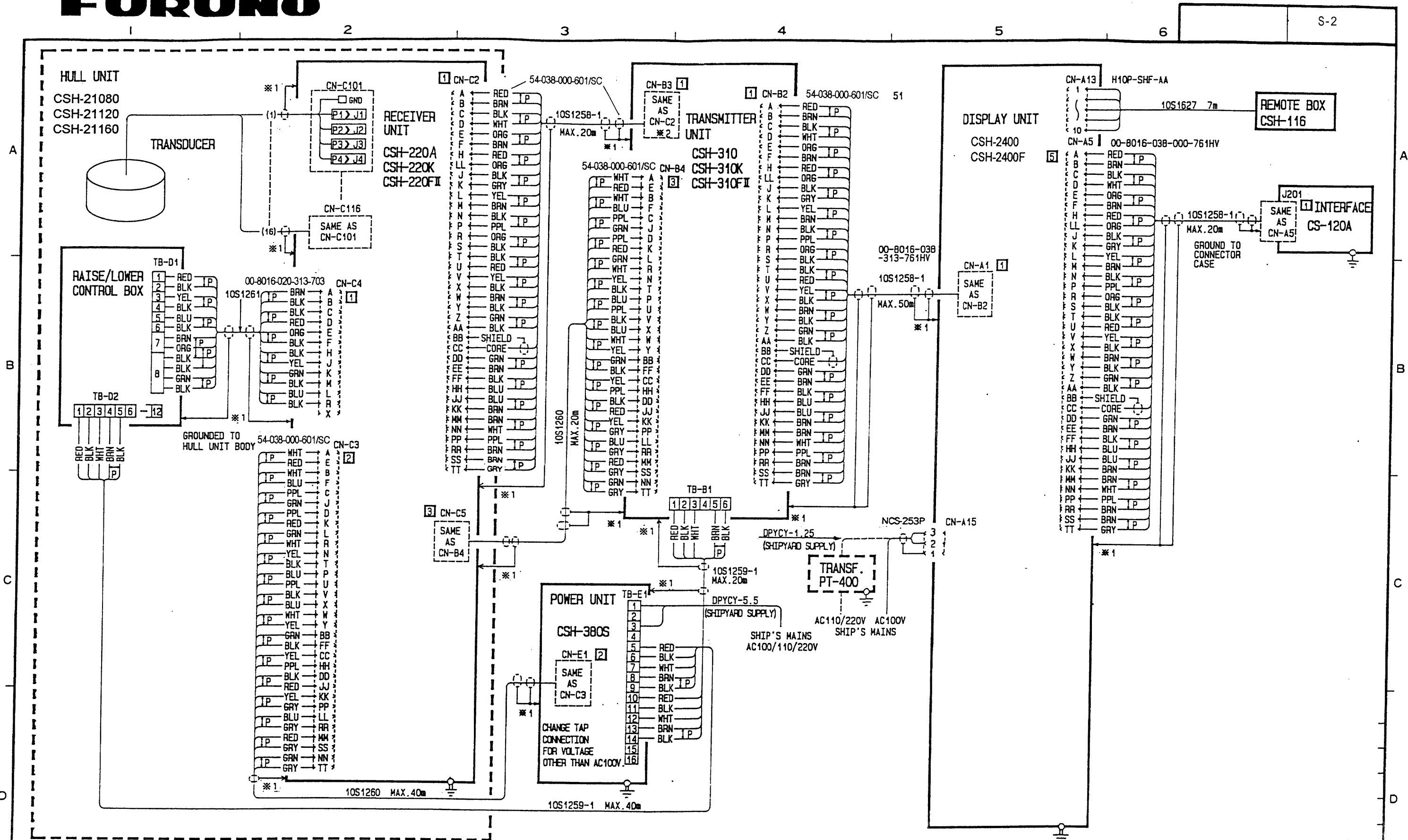

NOTE

1. ※1. GROUNDING THRU CABLE CLAMP.
2. NUMERAL IN □ SHOWS POSITION OF CONNECTOR GUIDE PIN (LARGE) GUIDE PIN (SMALL) IS SET ALWAYS TO POSITION "1".
3. ※2. CONNECT SHIELD TO CABLE GLAND INSTEAD OF "TT".

DRAWN <i>Mar 12 1988 T. YAMASAKI</i>		TYPE CSH-24/24F
CHECKED <i>Mar 12 1988 K. Kusumoto</i>		名称 カラスキャニングソナー
APPROVED <i>Mar 12 1988 K. Kusumoto</i>		相互結線図
SCALE /	MASS kg	NAME COLOR SCANNING SONAR
DWG NO. E1310-C01-B	APPLICABLE TO: (MODEL)	BLOCK NO. NAME INTERCONNECTION DIAGRAM

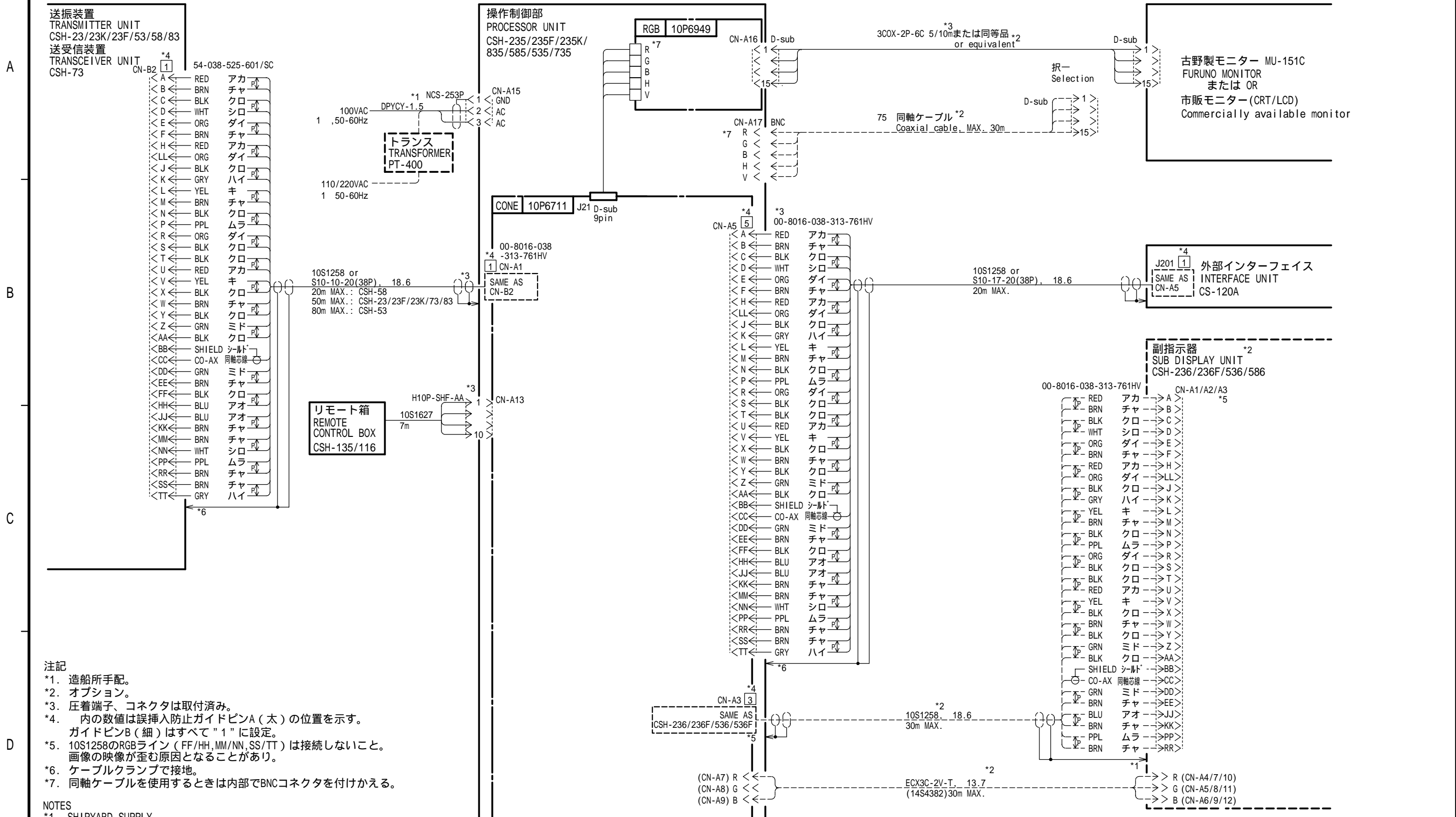

- 注記**
- *1. 造船所手配。
 - *2. オプション。
 - *3. 圧着端子、コネクタは取付済み。
 - *4. 内の数値は誤挿入防止ガイドピンA (太) の位置を示す。ガイドピンB (細) はすべて "1" に設定。
 - *5. 10S1258のRGBライン (FF/HH,MM/NN,SS/TT) は接続しないこと。画像の映像が歪む原因となることがあり。
 - *6. ケーブルクランプで接地。
 - *7. 同軸ケーブルを使用するときは内部でBNCコネクタを付けかえる。

- NOTES**
- *1. SHIPYARD SUPPLY.
 - *2. OPTION.
 - *3. CONNECTOR/LAG FITTED AT FACTORY.
 - *4. SHOWS POSITION OF CONNECTOR GUIDE PIN(LARGE). GUIDE PIN(SMALL) IS SET ALWAYS TO POSITION '1'.
 - *5. DO NOT CONNECT RGB LINE (FF/HH,MM/NN,SS/TT) ON 10S1258, OR INTERFERENCE MAY OCCUR ON DISPLAY.
 - *6. GROUNDED THRU CABLE CLAMP.
 - *7. WHEN COAXIAL CABLES ARE USED, REPLACE THE BNC CONNECTORS.

DRAWN	Feb. 15, '05 E. MIYOSHI	TITLE	CSH-235/235F/235K/835/585/535/735
CHECKED	TAKAHASHI. T	NAME	カラスキャニングソナー操作制御部
APPROVED	Y. Hatai		相互結線図
SCALE	MASS kg	REMARK	COLOR SCANNING SONAR PROCESSOR UNIT
DWG No.	C1304-C01- B		INTERCONNECTION DIAGRAM

1 2 3 4

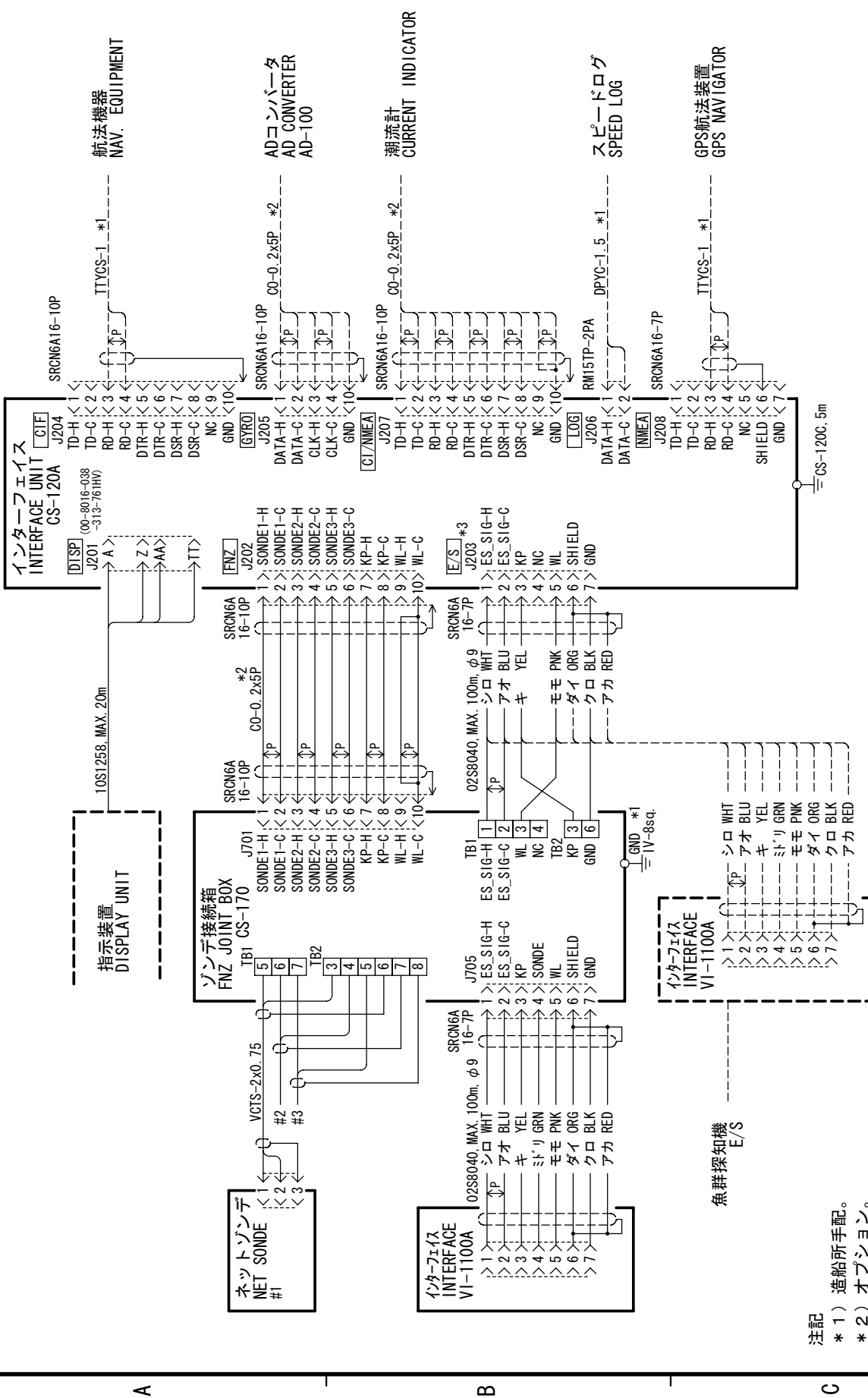

注記

- * 1) 造船所手配。
- * 2) オプション。
- * 3) 魚探が一台のときのみ接続。

NOTE

- *1. SHIPYARD SUPPLY.
- *2. OPTION.
- *3. USE ONLY FOR ONE E/S UNIT CONNECTION.

ネットソナー不使用時
WHEN NET SONDE IS NOT USED.

DRAWN	Jun. 19 '06	I. YAMASAKI	TITLE	CS-120A
CHECKED	JUL. 4 '06	T. TAKENO	名称	インターフェイス
APPROVED	JUL. 24 '06	T. Matsuguchi	相互結線図	
SCALE		MASS	INTERFACE UNIT	
DWG. No.		C1238-003-III	INTERCONNECTION DIAGRAM	

Free Manuals Download Website

<http://myh66.com>

<http://usermanuals.us>

<http://www.somanuals.com>

<http://www.4manuals.cc>

<http://www.manual-lib.com>

<http://www.404manual.com>

<http://www.luxmanual.com>

<http://aubethermostatmanual.com>

Golf course search by state

<http://golfingnear.com>

Email search by domain

<http://emailbydomain.com>

Auto manuals search

<http://auto.somanuals.com>

TV manuals search

<http://tv.somanuals.com>