

No. : OM-E2315-0B

FURUNO

OPERATOR'S MANUAL

ECHO SOUNDER

MODEL FE-4300

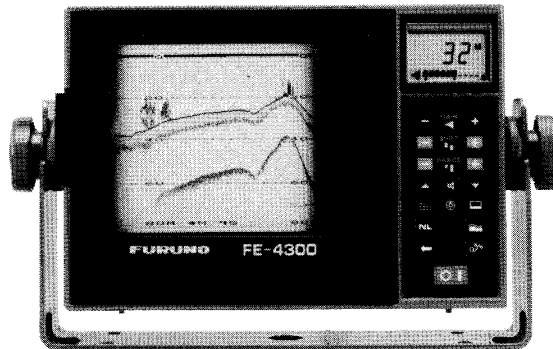

FURUNO ELECTRIC CO., LTD.
NISHINOMIYA, JAPAN

890150KS (8901, tami)
PRINTED IN JAPAN



FURUNO ELECTRIC CO., LTD.

No. 9-52, ASHIHARA-CHO,
NISHINOMIYA-CITY, JAPAN

TELEPHONE : 0798-65-2111
CABLE : FURUNO NISHINOMIYA
TELEX : 5644-325/326 FURUNO J
TELEFAX : 0798-65-4200 (G II /G III)

YOUR LOCAL AGENT/DEALER

A WORD TO FURUNO FE-4300 OWNERS:

Congratulations on your choice of the FURUNO FE-4300 Echo Sounder. We are confident that you will enjoy many years of operation with this fine piece of equipment.

For over 40 years Furuno Electric Company has enjoyed an enviable reputation for quality and reliability throughout the world. This dedication to excellence is furthered by our extensive global network of agents and dealers.

The FE-4300 Echo Sounder is just one of the many Furuno developments in the field of echosounding. The compact, lightweight but rugged unit is easy to install and operate and is suitable for both fresh and salt water applications.

This unit is designed and constructed to give the user many years of trouble-free operation. However, to obtain optimum performance from this unit, you should carefully read and follow the recommended procedures for installation, operation and maintenance. No machine can perform to the utmost of its ability unless it is installed and maintained properly.

We would appreciate feedback from you, the end-user, about whether we are achieving our purposes.

Thank you for considering and purchasing Furuno equipment.

FEATURES

The FE-4300 has a large variety of functions, all contained in a splash-proof rugged aluminum die cast case that is compact to fit almost any size boat.

All keys respond immediately to the operator's command and each time a control touchpad is pressed an audible "beep" sounds to confirm that the command has been received by the unit.

- * The unique LCD window provides the operator with instant recognition of equipment status.
- * Performance of the unit can be monitored by means of the simple to operate built-in test circuit.
- * Shadow Line control makes discrimination of fish close to the bottom and the bottom itself easier.
- * Three paper advance speeds for detailed observation of fishing conditions.
- * Easy paper loading.
- * Extremely effective noise limiter eliminates interference with minimal effect on desired echoes.
- * Six Basic Ranges, from 0-15Ft. to 0-960Ft. Unit of measurement may be changed from Feet to Fathoms or Meters.
- * Phased Range allows start of Basic Range to be set from 0 Feet to a maximum of 960 Feet in Basic Range 7.
- * Five Pulselengths from 0.1 to 1.2 msec. for excellent short range and deep range performance, with different Sounding Rates.
- * Potent 100W transmitter, with sensitive receiver.
- * Universal 11-15VDC power supply, drawing less than 10W of power.
- * The stand-by key allows the unit to be used as a simple depth indicator.

TABLE OF CONTENTS

* * * * *

	<u>Page</u>
SPECIFICATIONS	1 to 3
PRINCIPLE OF OPERATION	4
INSTALLATION	
TRANSDUCER INSTALLATION	5
Through-Hull Mount	6
Sideboard Installation (Option)	8
Transom Mount (Option)	9
Inside Hull	10
Transducer Preparation and Painting	10
RECORDER UNIT INSTALLATION	11
Mounting Location	11
Mounting Recorder Unit	11
CABLE CONNECTIONS	12
Transducer Cable Connection to Recorder Unit	13
Power Cable Connection	13
GROUNDING	13
LOADING OF RECCORDING PAPER	14
OPERATIONAL OVERVIEW	
CONTROLS	15
Power Switch	15
Range Selection	16
Paper Advance Speed Key	17
Gain Control	18
Shadow Line Key	19
Noise Limiter	19
Alarm Key	20
Bottom-Lock Key	20
Range Marker Key	21
Paper Illumination Key	21
Stand-by Key	21
INDICATORS	21
INTERPRETING THE RECORDING	
DETECTING AREA	25
ZERO LINE	26
FISH SCHOOL ECHOES	26
BOTTOM ECHO	26
SURFACE NOISE/AERATION	27

MAINTENANCE	
GENERAL	28
STYLUS REPLACEMENT	28
FUSE REPLACEMENT	29
CLEANING AND LUBRICATION	29
MAINTENANCE OF THE TRANSDUCER	29
TROUBLESHOOTING	
BASIC TROUBLESHOOTING FOR USER	30
MORE EXTENSIVE TROUBLESHOOTING FOR SERVICE SHOP	31
LCD Module Display	31
S-RAM Check	31
Recorder Output	32
Keyboard Operation	32
Troubleshooting by Self-Check	33
Check guide for Troubleshooting	34
TRANSDUCER CHECK	35
HOW TO CHANGE INTERNAL SETTING	36
CHANGE OF DEPTH MEASUREMENT UNIT	36
EXPLODED VIEW AND PARTS LIST	37
SCHEMATIC DIAGRAM	38
APPENDIX	
ADJUSTMENT OF RECORDING STYLUS PRESSURE	AP-1

SPECIFICATIONS

1. Basic Range

Setting	1	2	3	4	5	6	7
Meters	0- 5	0-10	0-20	0- 40	0-80	0-160	0-320
Feet	0-15	0-30	0-60	0-120	0-240	0-480	0-960
Fathoms	0-2.5	0- 5	0-10	0- 20	0-40	0- 80	0-160

Note: Units are selected with an internal jumper block.

2. Phased Range

B.R. Setting	1	2	3	4	5	6	7	
S T E P	Meters	1	2	5	10	20	40	80
	Feet	5	10	15	30	60	120	240
	Fathoms	1	1	2	5	10	20	40
M A X	Meters	325	330	340	360	400	480	640
	Feet	975	990	1020	1080	1200	1440	1920
	Fathoms	162.5	165	170	180	200	240	320

3. Bottom Lock Range

5 meters, 15 feet or 2.5 fathoms

Bottom lock expansion is registered on the lower 1/3 of the paper.

4. Pulselength/Sounding Rate

End of Range	Pulselength	Sounding Rate
0- 10 m	0.1ms	288 to 72 ppm (Automatically determined by the range setting.)
11- 80	0.2	
81-160	0.4	
161-320	0.8	
321-640	1.2	

5. Indication

(AYPD1015NW)

4" Dry Paper Recording : PD-1015NW 100mm x 15m
LCD display : Depth readout and Gain settings.

Note: The selected Basic Range, Phased Range and Depth Alarm are also indicated with their symbols for confirmation of the status of the equipment. These indications are held for a few seconds after key operation is completed.

6. Paper Advance Speed

1 (or S; slow)	10mm/min.
2 (or M; medium)	18mm/min.
3 (or F; fast)	33mm/min.

Note: Each paper speed is automatically determined by the selected range, but selectable by the touchpad key in three steps.

7. Paper Loading

Easy loading cassette

8. Transmitter Output 100W
9. Frequency 50kHz or 200kHz
10. Depth Alarm
- Alarm sounds when bottom echo comes into the preset alarm depth zone.
Alarm is not triggered by fish echoes between surface and bottom.
11. Echo Intensity 5 different intensities (White, Gray, D-Gray, Black and Shadow line) including background.
12. Power Supply 11-15 VDC, less than 10W
13. Dimensions and Weight 293(W) x 184(H) x 77(D)mm, 1.8kg

COMPLETE SET

	Name	Type	Code No.	Q'ty
1	Recorder Unit			1
2	Transducer	50B-5NR 200B-5NR	000-015-014* 000-015-028**	1
3	Installation Materials	00S0120	000-104-058	1set
4	Accessories	FP02-00500	000-024-927	1set
5	Spare Parts	SP02-01700	000-024-708	1set

* for 50kHz, ** for 200kHz

INSTALLATION MATERIALS

	Name	Type	Code No.	Q'ty
1	Power Cable Assy	00S0120	000-104-058	1

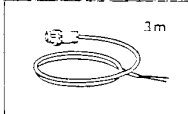

ACCESSORIES

	Name	Type	Code No.	Q'ty	Fig.
1	Hanger	22-011-1601	100-101-120	1	1
2	Rubber Cushion	02-052-1303	100-022-540	2	2
3	Winding Reel	FGS-210020-2	210-100-212	1	3
4	Knob Bolt	KG-B2, M8x20	000-801-738	2	4
5	Knob Washer	05-012-0125-1	591-201-251	2	5
6	Rubber Washer	22-012-1302	100-101-130	2	6
7	Tapping Screw	6x20, SUS	000-800-414	4	7

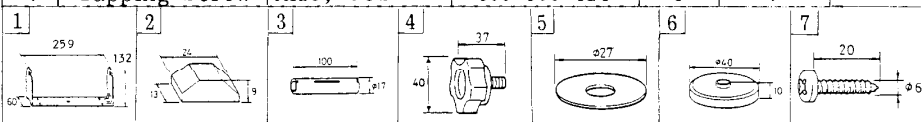

SPARE PARTS

	Name	Type	Code No.	Qty	Fig.
1	Fuse	FGMB 2A 125V	000-103-165	2	1
2	Recording Stylus	02-055-1518-1	100-031-071	1	2
3	Collector Stylus	02-055-1519-1	100-031-081	1	3
4	Sandpaper	02-055-1125-0	100-030-710	1	4
5	Sponge Brush	02-055-1115-0	100-030-620	1	5
6	Recording Paper	PD-1015NW	000-873-456	1	6

AYPD1015NW

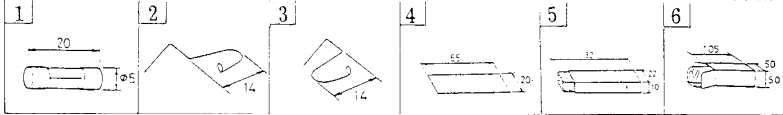

PPAL =
4" Dry/White

OPTION

	Name	Type	Code No.	Qty
1	Transducer	NBM-40-50-11	000-015-083	1
		50B-6B	* 000-015-043	
		50B-6G	000-015-016	
		TBM-50-200-19	000-015-029	
		UT200LF-8A	** 000-015-036	
		200B-5	000-015-027	
2	Connector	200B-5S	000-015-029	1
		FM143P	*** 000 511 405	
3	Suction Cup and Bracket	OP02-15	000-013-633	1
4	Adhesive		000-856-518	15g

- * 50 kHz
- ** 200 kHz
- *** For connection

TANK LIST FOR OPTIONAL SUPPLY TRANSDUCERS

Frequency	Transducer	T A N K			
		STEEL	FRP	WOOD	SIDEBORD
50kHz	50B-6B Code Number	T-605 000-015-515	T-605-F 000-015-516	T-605-W 000-015-517	T-27 000-015-313
	50B-6G Code Number	---	---	---	T-27A 000-015-558
200kHz	200B-5S Code Number	T-605 000-015-515	T-605-F 000-015-516	T-605-W 000-015-517	T-27 000-015-313
	200B-5 Code Number	---	---	---	T-31A 000-015-334
Thru-Hull Pipe		TFR-5000 000-015-206	TRR-1000 000-015-215	TFR-1000 000-015-201	---

PRINCIPLE OF OPERATION

The FE-4300 Echo Sounder determines the distance between its transducer and underwater objects such as fish, lake bottom or seabed and displays the results on 4" recording paper. It does this by utilizing the fact that an ultrasonic wave transmitted through water travels at a nearly constant speed of 4800 feet (1500m) per second. When a sound wave strikes an underwater object such as fish or sea bottom, part of the sound wave is reflected back toward the source. Thus by calculating the time difference between the transmission of a sound wave and the reception of the reflected sound wave, the depth to the object can be determined. In a sense an echo sounder can be thought of as being an extremely sophisticated and quick timer, since it is capable of resolving time differences shorter than one thousandth of a second.

The entire process begins in the recorder unit. Transmitter power is sent to the transducer as a short pulse of electrical energy. The electrical signal produced by the transmitter is converted into an ultrasonic signal by the transducer and transmitted into the water. Any reflected signals from intervening objects (such as a fish school) are received by the transducer and converted back into an electrical signal. It is then amplified in the amplifier section, and finally, recorded on the paper.

The recording printed by the FE-4300 is made up of a series of vertical scan lines, one line for each transmission. Each line represents a "snapshot" of what has occurred beneath the boat. The series of snapshots are accumulated side by side across the paper, and the resulting contours of the bottom and fish between the bottom and surface are recorded. The amount of history of objects that have passed beneath the boat over a series of transmission varies from a few minutes to several minutes, depending on how you adjust the unit. For further details, see page 17, Paper Advance Speed key.

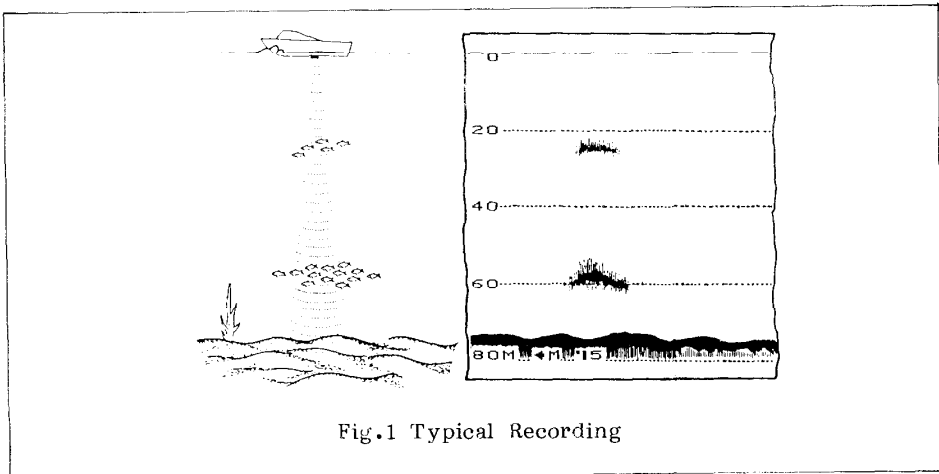

INSTALLATION

TRANSDUCER INSTALLATION

The performance of the echo sounder depends greatly upon the transducer position. A place least affected by AIR BUBBLES should be selected since turbulence blocks sounding capability. Also select a place least influenced by ENGINE NOISE. The following figure shows typical transducer installation site.

It is known that bubbles are at a minimum at the place where the first bow wave falls and the next wave rises at general cruising speed. In small slowspeed boats, the following position is usually a good place.

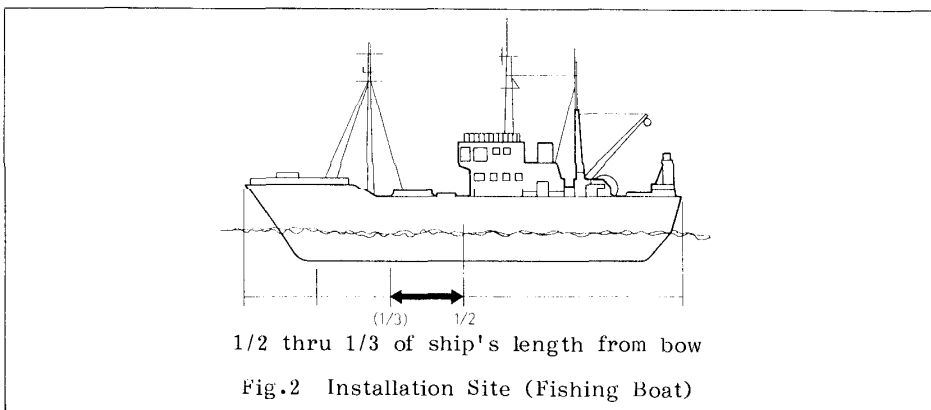

The transducer can also be installed on the sideboard using a pipe and clamps, but note that the boat has to be small in size and its speed slow.

For the pleasure boats, the acceptable transducer locations are shown below. The transom/inner-hull methods are commonly used.

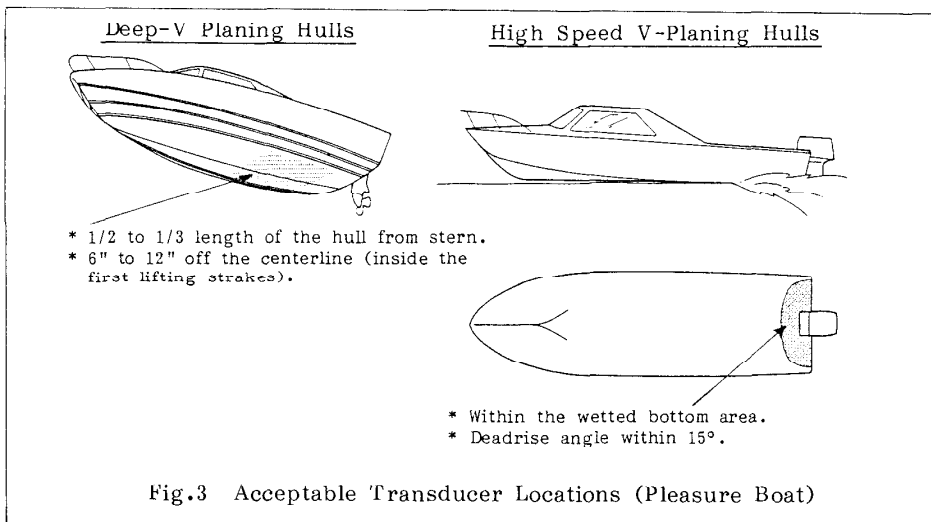

Through-Hull Mount

This type of mounting provides the best performance of all, since the transducer protrudes from the hull and the effect of air bubbles and turbulence near the hull skin is reduced. To determine the transducer location, keep in mind the general considerations described on page 5. Also, when the boat has a keel, the transducer should be at least 30 cm (1 foot) away from it. Typical through-hull mountings are illustrated in fig.4.

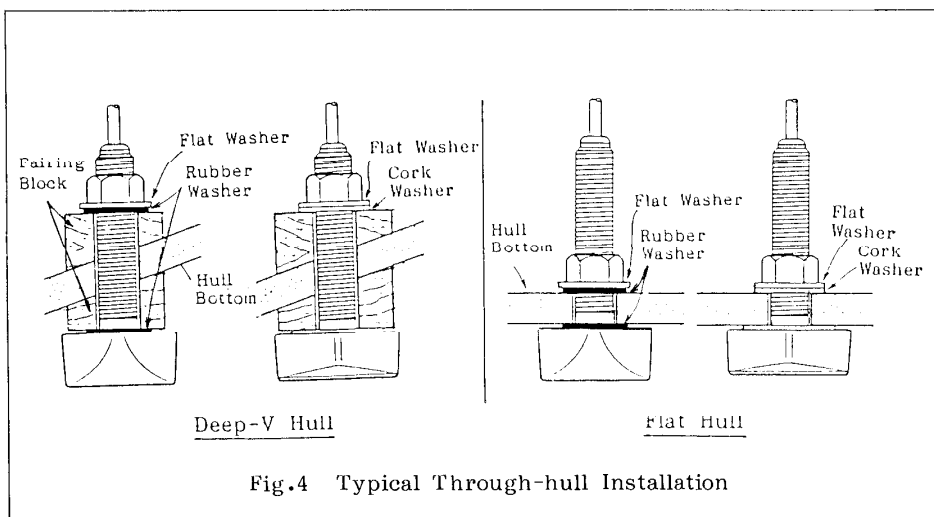

Through-hull mounting is accomplished as follows.

1. With the boat hauled out of the water, mark the location selected for mounting the transducer on the bottom of the hull.
2. If the hull is not level within 15 degrees in any direction, fairing blocks made out of teak should be used between the transducer and hull, both inside and outside, to keep the transducer face parallel with the water line. Fabricate the fairing block as shown in fig.5 and make the entire surface as smooth as possible to provide an undisturbed flow of water around the transducer. The fairing block should be smaller than the transducer itself to provide a channel to divert turbulent water around the sides of the transducer rather than over its face.
3. Drill a hole just large enough to pass the threaded stuffing tube of the transducer through the hull, making sure it is drilled vertically.
4. Apply a sufficient amount of high quality caulking compound to the top surface of the transducer, around the threads of the stuffing tube and inside the mounting hole (and fairing blocks if used) to ensure watertight mounting.
5. Mount the transducer and fairing blocks and tighten the locking nuts. Be sure that the transducer is properly oriented and its working face is parallel to the waterline. Do not over-stress the stuffing tube and locking nuts through excessive tightening, since the wood block will swell when the boat is placed in the water. It is suggested that the nut

tightened lightly at installation and retightened several days after the boat has been launched.

CAUTION

The tightening torque should not exceed 400kg-cm. Excessive stress will cause damage to the threads of the plastic stuffing tube.

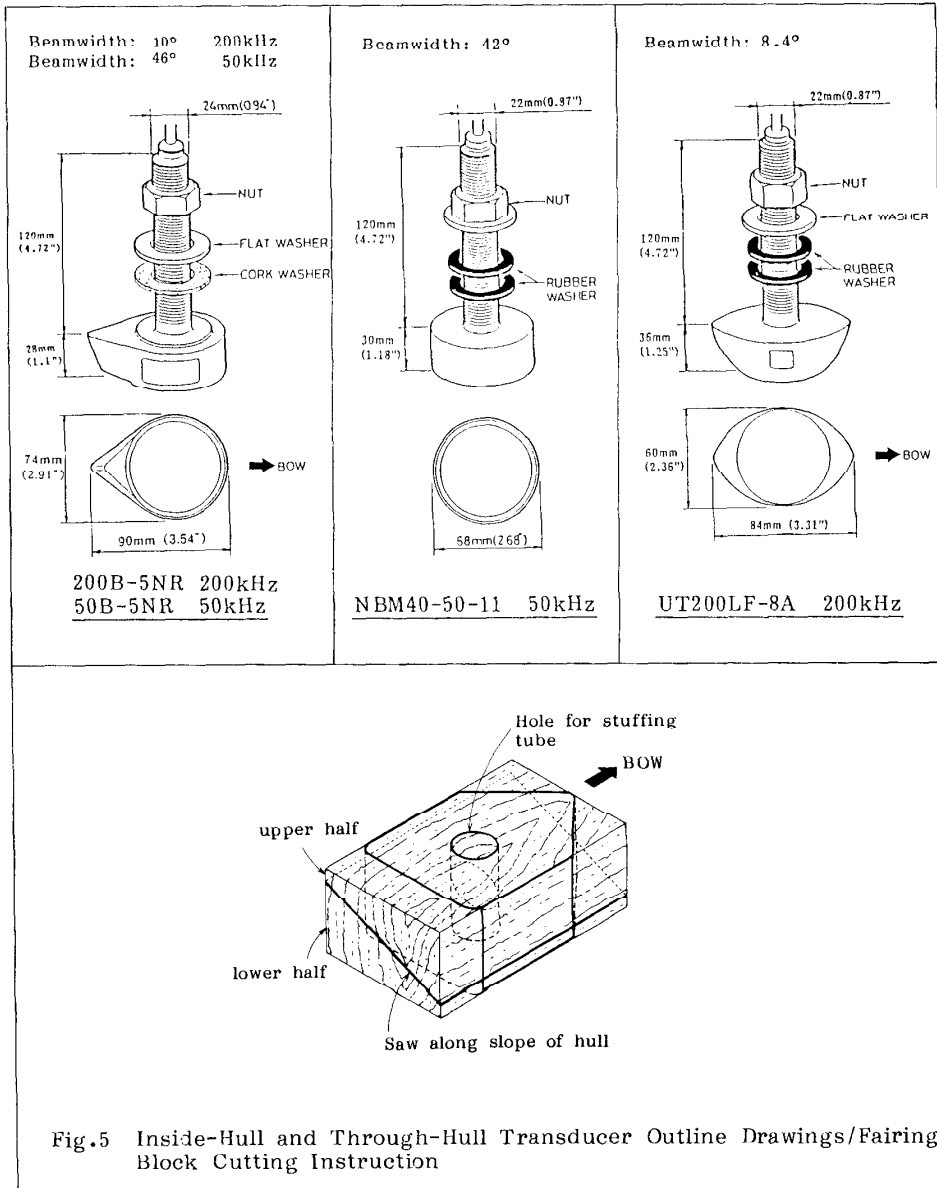

Fig.5 Inside-Hull and Through-Hull Transducer Outline Drawings/Fairing Block Cutting Instruction

Sideboard Installation (Option)

This method is recommended for the small fishing boats. As it doesn't need to make a hole at the bottom hull, the sideboard installation is accepted as a simpler way of installation. However mind the ship's speed for the protection of the pipe assembly. Fig. 6 shows the example of sideboard installation. The transducer should be submerged deep enough to avoid the effect of air bubbles during cruising.

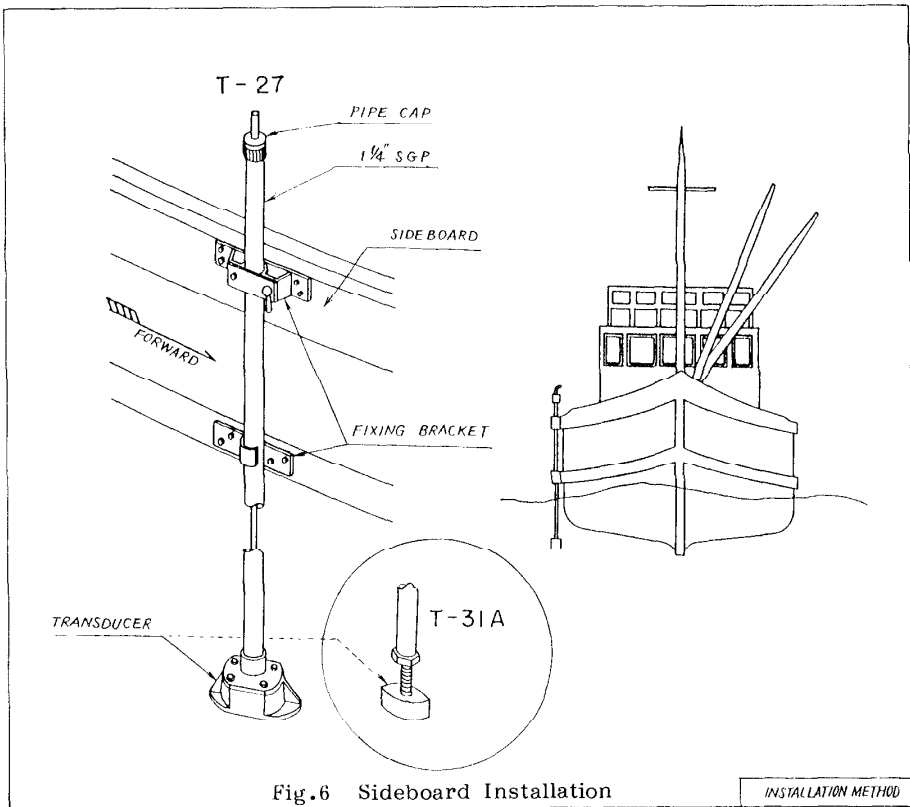

Fig.6 Sideboard Installation

INSTALLATION METHOD

Transom Mount (Option)

This type of mounting is very commonly employed, usually on relatively small I/O or outboard boats. Do not attempt this mounting on an inboard boat due to turbulence created by the propeller ahead of the transducer.

1. Attach the transducer to the bracket as shown in fig.7.
2. To determine a suitable transducer mounting location, run the boat at several speed ranges and observe the water flow at the rear and near the transom.

Suitable location is at least 50 cm (18") away from the engine and where the water flow is smooth.

3. On a relatively flat hull, the transducer is mounted flush with the transom, and on a deep "V" hull, it is usually mounted so that the transducer face is parallel with the seabed. A fairing block should be installed ahead of and flush with the transducer to assure clean water flow across the transducer face.

Mark the screw locations by holding the transducer in position on the transom.

4. Drill four pilot holes for the mounting screws.
5. Mount the transducer and secure it with four self-tapping screws. A small amount of sealing compound under the head of each screw will preserve the watertight integrity of the transom.
6. Adjust the transducer position so that either its entire wedge front (for flat hull) or wedge front corner is flush with the transom bottom.
7. If necessary, to improve water flow and minimize air bubbles staying on the transducer face, incline the transducer about 5° at the rear. This may require a certain amount of experimentation for fine-tuning at high cruising speeds.
8. Fill the gap between the wedge front of the transducer and transom with epoxy material to eliminate any air spaces.

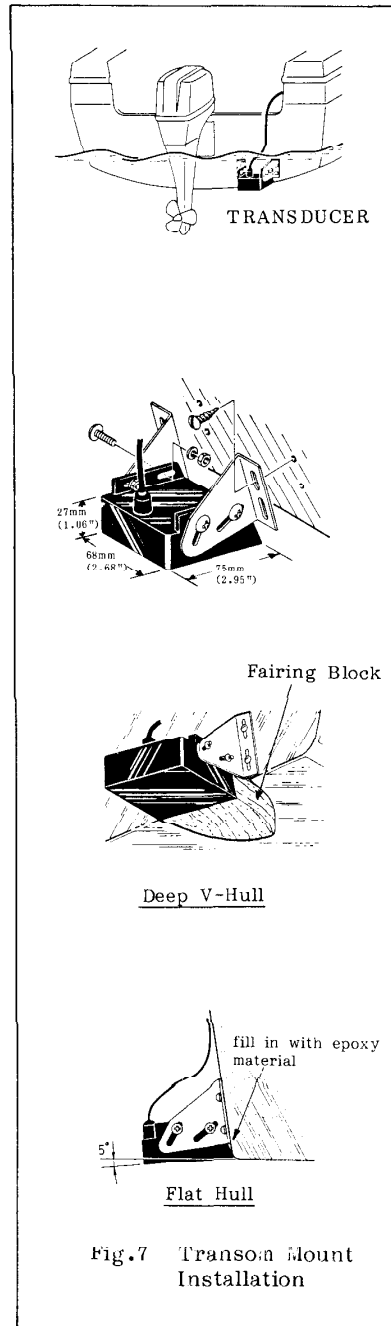

Inside-Hull Mount

While this is by no means an optimum mounting scheme for deep-water sounding, this type of mounting can sometimes be used on fiberglass boats. A transducer can be likened to an antenna used with a TV set. Mounting an antenna inside your attic is like mounting an echo sounder transducer inside the hull. Both will work well enough, but are hardly optimum for either TV or echo sounder operation. In addition to the general considerations described on page 5, it is important to ensure that the transducer be placed in an area that has a single-hull thickness and is void of air or flotation materials other than solid fiberglass between the transducer face and the water. Also, the transducer face should not be placed over hull struts or ribs which generally run under the hull. Further, a location where the rising angle of the hull exceeds 15° should be avoided to minimize the effect of the boat's rolling.

It is advisable that the mounting location be finalized through a little trial and error after all other installation works have been completed. Temporarily put some silicone grease (not the type that sets up after drying!) inside the hull. Push the transducer down to squeeze out any air bubbles. Turn on the FE-4300. Run the boat at various speeds and move the transducer to different locations to select the position where the best picture is obtained. Once a good location is found, you may permanently mount the transducer.

The inside-hull mounting is accomplished as follows. See fig. 5 on page 7 for outline drawings.

1. Lightly roughen the transducer face with fine #10 sandpaper and degrease it with a solvent (thinner or alcohol). Also, roughen and degrease the inside of the hull where the transducer is to be mounted.
2. Allow both to dry completely, then coat the transducer face and hull with the adhesive supplied. In a cold environment, you should warm the adhesive to approximately 40°C before usage to soften it. (See fig.8.)
3. Press the transducer firmly down on the hull and gently twist it back and forth to remove any air which may be trapped in the adhesive. Allow sufficient time for the adhesive to dry.

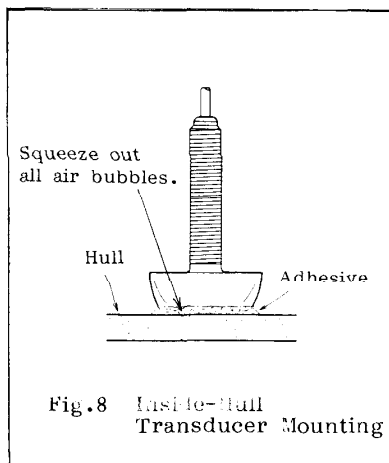

Transducer Preparation and Painting

Just prior to putting your boat into the water, the face of the transducer should be thoroughly wiped with a detergent liquid soap. This will lessen the time necessary for the transducer to establish good contact with the water. Eliminating this will lengthen the time required for complete "saturation" and will reduce the performance of the unit.

To maintain the sensitivity of the transducer, do not coat the face with heavy pigmented antifouling paints, i.e., cuprous oxide types. Use only a light, thin coat of a vinyl based antifouling paint, like International Paint's TRI-LUX No.67 or No.68.

RECORDER UNIT INSTALLATION

Mounting Location

The recorder unit is carefully constructed to be able to withstand the humidity and corrosive atmosphere common in the marine environment, but it is not designed to be used outside, directly exposed to that environment. Salt water spray will most assuredly cause damage to the sensitive components inside. Keep these and the following factors in mind when planning the installation of the recorder unit.

CAUTION

Furuno will assume no responsibility for the damage caused by exposure to either fresh or salt water.

1. The recorder unit consumes very little power, so there is no need of forced air ventilation. However it is necessary to provide at least some circulation of cooling air by allowing sufficient space around the unit.
2. Many owners will undoubtedly use the FE-4300 on small boats, many with center consoles. The recorder unit must be mounted inside an enclosed cabinet, completely shielded from salt water spray, and from fresh water spray if the boat is usually hosed down after a day's outing. Most small center console boats are equipped with such an enclosed cabinet behind the wheel, and most have clear doors so that equipment may be seen behind them.
3. It is recommended to keep the recorder unit out of direct sunlight or at least shaded because of heat that can build up inside the cabinet.
4. Consideration should be made to provide space for access to the mounting hardware on the side and connectors behind the recorder unit (see fig.9 for unit dimensions). Also allow at least a foot or so of "service loop" in the cables to allow the unit to be pulled forward for servicing or internal adjustment.

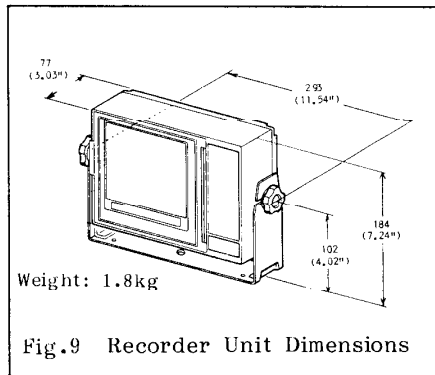

5. The recorder unit can be mounted on either a table-top, bulkhead or overhead. Make sure that the selected location is strong enough to support the unit under the conditions of continued vibration or shock which will be normally encountered on the boat. If necessary, appropriate reinforcement measures should be taken in the mounting area.

Mounting Recorder Unit

1. Mark the screw locations by using the mounting hanger as a template. (See fig.10.)
2. Drill four pilot holes for the mounting hanger.

3. Install the mounting hanger using the screws supplied.
4. Fit knobs, rubber washers and knob washers to the recorder unit.
5. Install the recorder unit in the mounting hanger. Tighten the knobs securely.

CAUTION

If the hanger vibrates too much from side to side, use the supplied rubber cushions to absorb the vibrations.

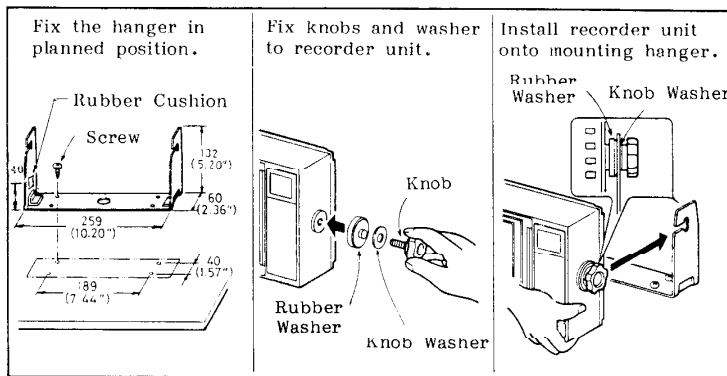

Fig.10 Mounting the Recorder Unit

CABLE CONNECTIONS

Cable connections to the FE-4300 recorder unit are made at the connectors located at the rear of the unit. Fig.11 shows the wiring instructions.

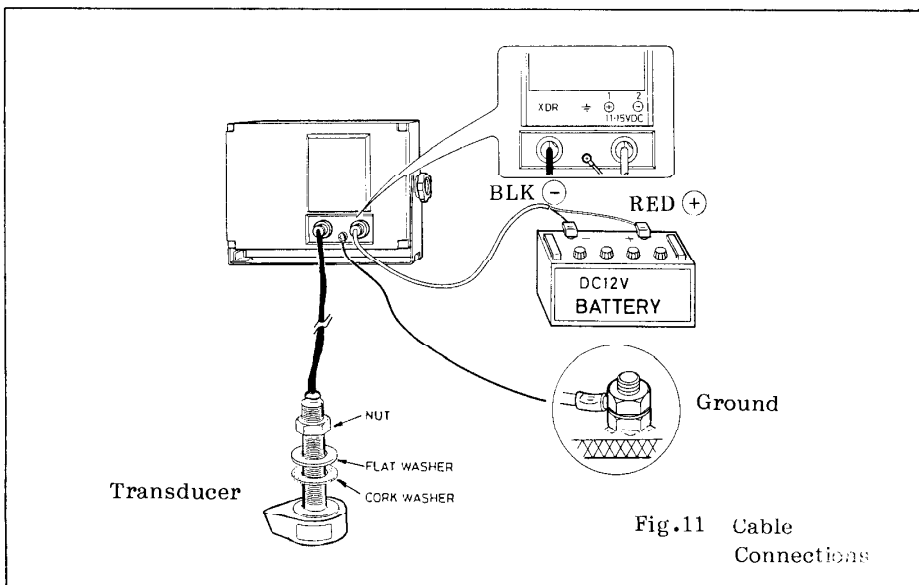

Fig.11 Cable Connections

Transducer Cable Connection to Recorder Unit

In order to minimize the chance of picking up electrical interference, avoid where possible routing the transducer cable near other on-board electrical equipment. Also avoid running the cable in parallel with power cables.

Power Cable Connection

The FE-4300 is designed to operate normally at any voltage between 11 and 15Vdc. The power should be directly taken from the distribution board or breaker panel.

Connect the red lead of the cable to the positive (+) terminal of the battery and the black lead to the negative (-) terminal.

CAUTION

REVERSING THE POLARITY WILL RESULT IN
BLOWING THE FUSE AND MAY VERY WELL DAMAGE
INTERNAL COMPONENTS.

GROUNDING

The FE-4300 is designed to operate normally without grounding the recorder unit, provided that the cable routing precautions stated before are taken. However in some cases, interference may show up at high gain settings, and it may become necessary to ground the unit to the boat's grounding bus to eliminate the problem. In such cases, run a heavy duty ground wire from the grounding terminal on the rear bottom of the recorder unit to the nearest grounding point on the boat.

On a fiberglass boat, it is best to install a ground plate that measures about 20 cm by 30 cm (0.8 feet by 1.0 feet) on the outside of the hull bottom to provide a ground point. If this is not practical, the engine block can be used.

LOADING OF RECORDING PAPER

Prior to operating the FE-4300, it is necessary to load the recording paper into the unit. Loading is made easy by means of a cassette-type paper holder. The procedure for paper loading is shown in fig.12 below.

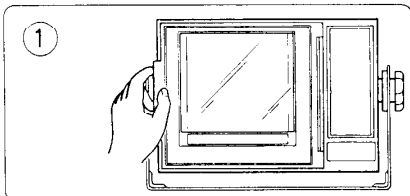

Open the front panel.

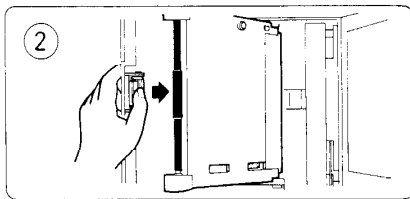

Press the clamer, and the cassette for paper loading will pop-out. Take it out from the main unit.

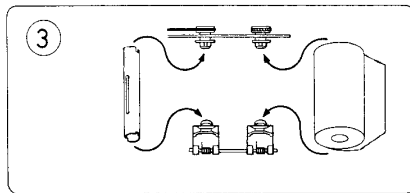

Feed the recording paper referring to the illustration at left, and wind the paper to correct a sag.

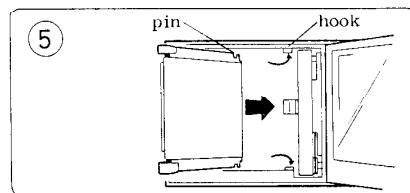
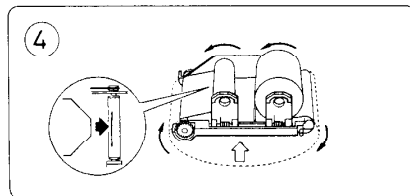

Insert the loading cassette into its compartment, making sure the pin and hook are mated. You should hear a click sound indicating that the cassette is engaged correctly.

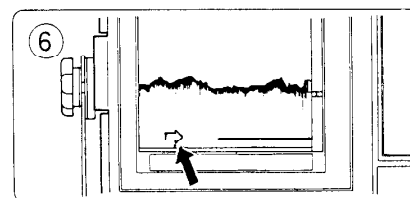

When a red arrow appears on the roll this indicates 1.5 meters of paper remains. (The mark appears when 10% of the total length of the roll remains.)

Fig.12 Loading the Recording Paper

OPERATIONAL OVERVIEW

The FE-4300 is very easy to operate. For most operations, each time a control touchpad is pressed an audible "beep" is produced to signal the operator that the unit has received his command. Furthermore, if you hold down any of the upper-four control touchpads, the appropriate on-LCD indications will automatically increment, either upwards or downwards. The lower-four touchpads are on-off switches and their status appears on both the recording paper and the LCD window.

The Recorder Unit is separated into two sections; controls on the right-hand side with a small LCD window, and the recording part on the left-hand side. Most of the touchpad controls have associated with them an indication on the recording paper using the same label found on the touchpad. Changing a touchpad setting will cause a corresponding change in the indication on the LCD window for a few seconds and the recording paper, as well as a change in the appearance of the echoes being viewed.

To familiarize yourself with the controls of your unit, turn it on (presuming that it has already been installed) and try pushing some of the keys as you review this section.

CONTROLS

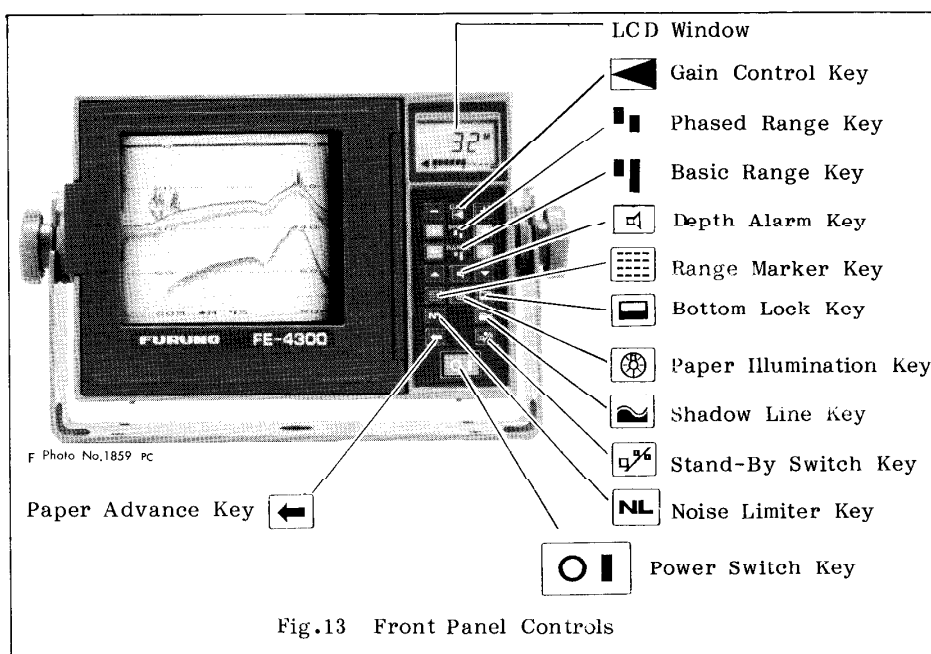

Power Switch Key:



Power is supplied to the unit by pressing the power switch key. Every time power is applied, the internal settings will default to the following:



Phased Range: "0"	Shadow Line: "OFF"
Basic Range: "4"	Range Marker: "ON"
Paper Advance Speed: "2"(M)	Paper Illumination: "OFF"



Noise Limiter:	"OFF"	Stand-by:	"OFF"
Alarm:	"OFF"	Gain Control:	"5"
Bottom Lock:	"OFF"		

To turn off the unit, press the power switch again.

Range Selection:

The  Basic Range and  Phased Range keys used together give the operator the means to select the depth he can observe directly under the boat. The Basic Range can be thought of as providing a "window" into the water column. The start of this window is determined by the setting of the Phased Range selection. For example, if you select Basic Range 5, you will have a 240-foot deep viewing area, which may be moved anywhere in the water column by using the Phased Range key. To continue our example, if the Phased Range selector is set to 60 feet, the top of the range window would be at 60 feet, and the bottom of the range window would be at 240 plus 60 feet, or 300 feet.

You may want to look closely at the symbols for these two Range functions. The Basic Range symbol  is on the third line of the control keyboard, and the short bar next to the longer bar indicates that pushing this key will change the "window" size. The Phased Range  symbol on the other hand shows two equally sized bars that are staggered vertically next to each other, indicating that the start of the range window is determined by these keys. The Phased Range keys are placed on the second line.

Basic Range Keys:   









Press the  key once to increase the depth range and the  key once to lower it. As explained previously, holding down either key continuously increases/decreases the range setting much more rapidly until the minimum or maximum is reached. The Basic Range symbol  and the selected range are displayed on the LCD window for about 2 seconds after you press the touchpad key. The table below shows the size of each Basic Range "window."

Table 1 Basic Range Settings

Setting	1	2	3	4	5	6	7
Meters	5	10	20	40	80	160	320
Feet	15	30	60	120	240	480	960
Fathoms	2.5	5	10	20	40	80	160

Phased Range Keys:   

Press the  key once to increase the Phased Range start and the  key once to lower it. The Phased Range symbol and selected phased range value will be displayed at the top of the LCD window. The table below shows the size of each increment of phasing, depending on the Basic Range setting in use.

If you are presently using a small Basic Range window and a large Phased Range setting to set the start of the display window, and should you want

to change the phasing back to zero, then you would find that this can be accomplished by holding down the Phased Range key continuously, but since the increments of change are small, that it would take a long time to get back to zero. In this case, it is better to change the Basic Range to a higher setting, and then hold down the Phased Range key to get back to zero phasing more quickly.



For example, if you are using a Basic Range setting of 2 (30-foot range window), and a Phased Range setting of 550 feet, a single push on the  Phased Range key will cause a change of only 10 feet, meaning that you will have to hold down the key for a rather long time before getting to zero. Instead, change the Basic Range to 7 (960-foot window). Now the increments of change for the Phased Range keys are 240 feet, and you can get back to zero quickly. Return the Basic Range back to what you want after this.

Table 2 Phased Range Settings

B.R. Setting	1	2	3	4	5	6	7	
S T E P	Meters	1	2	5	10	20	40	80
	Feet	5	10	15	30	60	120	240
	Fathoms	1	1	2	5	10	20	40
M A X	Meters	325	330	340	360	400	480	640
	Feet	975	990	1020	1080	1200	1440	1920
	Fathoms	162.5	165	170	180	200	240	320

Paper Advance Speed Selection: 

Because the recording is built-up one recording line at a time, from right to left across the recording paper, the amount of history recorded on the paper is directly related to the paper advance speed.

There are three choices: 1 (or S ; slow), 2 (or M ; medium) and 3 (or F ; fast). The paper advance speed is changed by pressing the key successively as follows.

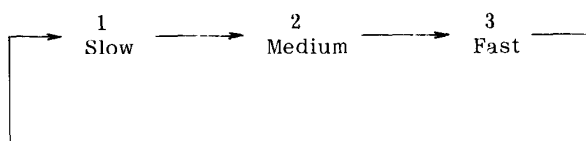

When you select or change the speed, the selected speed is indicated on the LCD display with the symbol  as well as on the lower part of the recording paper. However note that the selected speed is indicated by a numeral (1, 2 or 3) in the LCD window and by a letter (S, M or F) on the recording paper.

When selecting a speed keep in mind the following guidelines.

- 1) At faster advance speeds, care should be taken not to misjudge the size of the fish school; a fast advance rate speed will expand the size of the school horizontally across the paper. (fig.14a)
- 2) A slower advance speed however will contract the size of the school across the paper. (fig.14b)

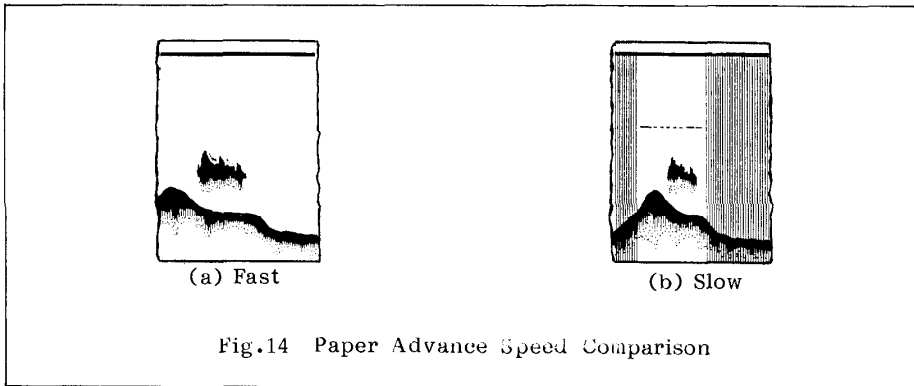

Fig.14 Paper Advance Speed Comparison

Gain Control Key:

The gain control keys adjust the sensitivity of the receiver. Normally, the gain is set to the point just below where excessive noise appears on the paper (see fig.15). As a general rule of thumb, use a higher gain setting for greater depths and a lower setting for shallower waters. For example, if you are looking for fish between the surface and the bottom in a range of perhaps 20 to 50 feet, you may not be concerned at all with seeing the bottom. You might use a Basic Range setting of 2 (30 foot range window) with a Phased Range setting of 20 feet. You would bring up the gain until excessive noise is shown on the paper and then you would back off just a little. Now fish will show when they are encountered.

As another example, if you are interested in seeing fish close to or on the bottom at 150 feet, you might be using a Basic Range of 5 (240-foot window) with a Phased Range setting of 0. Here you would bring up the gain until the bottom is printed in the strongest intensity level and then increase the gain a bit further until excessive noise appears between the surface and bottom. Again you would back off the gain until the noise just disappears. In both of these cases you are setting up the maximum level of useable gain, assuring you of the greatest possibility for seeing fish.

Press the key once to increase the gain and the key to decrease it. If you need to change the setting more quickly, hold down the key. The selected gain setting is indicated on the the lower part of the LCD window. If the gain is not set correctly, three decimal points will flicker in the LCD window.

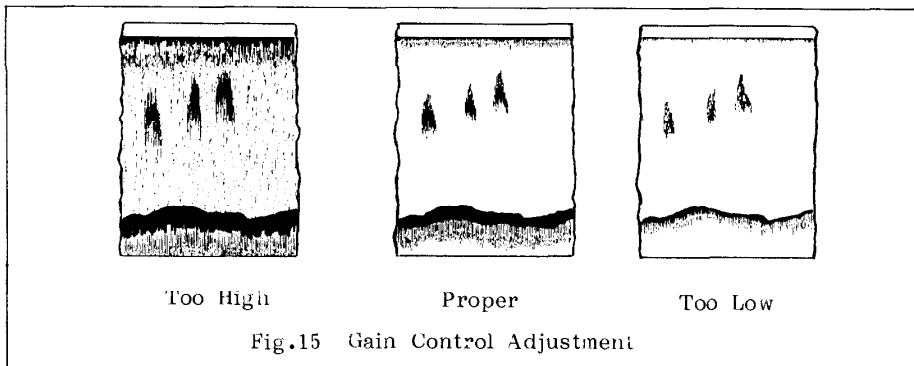

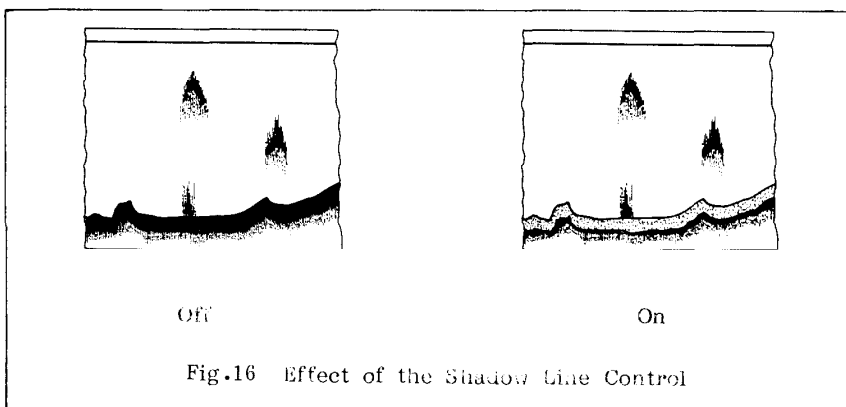



Fig.15 Gain Control Adjustment

Shadow Line Key: 

The Shadow Line Key is used for discriminating fish lying just above the bottom. Even though fish echoes are considerably weaker than bottom echoes, they may still be strong enough so that when the fish are close to the bottom, the two traces will merge and the fish trace will be indistinguishable from that of the bottom (see fig.16). The Shadow Line Key can be employed in this situation. It is most effective when the bottom is rocky and hard since the difference in echo strength from the bottom compared to fish is large. On mud, seaweed-covered, or sloping bottoms, where the echo differential is less, the benefit in using the Shadow Line Key will be less pronounced.





Noise Limiter: 

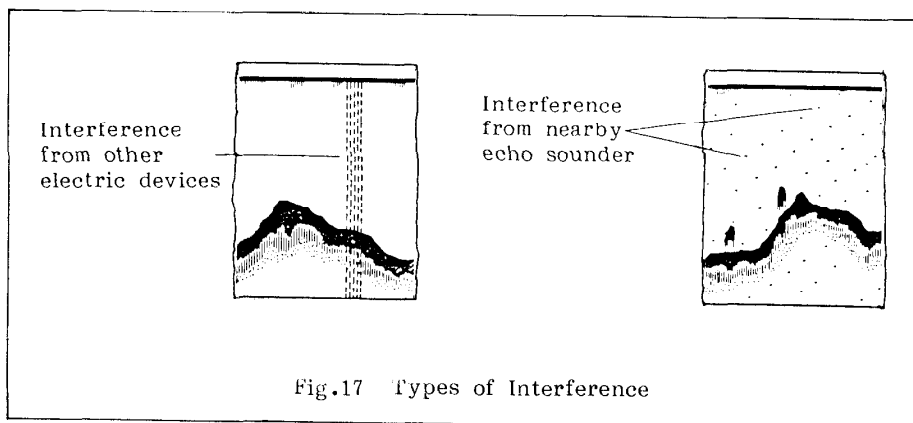

When noise interference from other echo sounders operating nearby or other types of electrical interference exist, you may use the Noise Limiter to eliminate or reduce the interference. (See fig.17.) If the Noise Limiter is left on when no interference exists, weaker echoes may be missed or eliminated. An "NL" symbol appears at the top of the LCD window and on the lower part of the recording paper to alert the operator that the Noise Limiter is "ON."







Alarm Key: 

There are two types of depth alarms that this unit is capable of generating: shallow or deep water. Which type of alarm the operator uses is determined by a setting inside the cabinet, which is normally shipped from the factory set to the Depth Alarm for shallow water.

The Depth Alarm is utilized to warn the operator that he is entering water shallower than set by the alarm, or drifting out to water deeper than set by the alarm. When activated, the Depth Alarm sounds only on bottom changes, fish echoes between the surface and bottom will not trigger the alarm. The  key is used to activate/deactivate the Depth Alarm and the   keys are used to set the depth of the alarm.

Depth Alarm:   

The Depth Alarm can be thought of as a zone extending from the transducer down to a depth of water greater than the draft of the boat. In waters where the depth is known to dramatically and suddenly rise without warning, it may be a good idea to set the Depth Alarm 10 (or even 20) feet below the boat's draft to warn of impending danger. For example, let us say that your boat has a draft of 3 feet, (i.e., the transducer is flush with the hull bottom, 3ft. below the surface) but you want to set a lower limit of 10 feet below the transducer as an alarm zone. Press  to activate the alarm. A  symbol will appear at the top of the LCD window and the lower part of the recording paper.

Now use the  Alarm Depth Key to set the depth of the alarm to 10 feet. The depth set by the alarm keys is displayed for a few seconds in the LCD window and on the recording paper with a dashed line. If you overshoot 10 feet, use the  key to get back to 10 feet. Now should the bottom rise into the indicated depth, the alarm will sound and you know you must exercise caution before proceeding any further. Note that the Depth Alarm only works more than 3ft. below the transducer to avoid locking on the transmission "main bang."

When activated and there is no bottom echo, the alarm sounds to warn the operator to set the gain correctly or turn off the alarm.

Bottom-Lock Key: 

The  Bottom-Lock key enables you to take a closer look at what is happening on the bottom while maintaining a normal recording. Press the Bottom-Lock Key once, the recording is divided into two parts: upper 2/3 of the paper for normal recording and lower 1/3 for bottom lock recording. As the size of this window is determined to 15 feet (irrespective of the range setting) and printed on the lower 1/3 of the paper, you can see what is occurring on or near the bottom with an expanded scale. See the figure on the next page.

Note that using the Bottom-Lock Key is based on a sufficient gain setting, in other words the bottom echo is clearly detected. If not, no bottom-lock recording is obtained on the lower part of the paper and the LCD window does not display depth but three flickering decimal points. Press the key again to revert to normal recording.

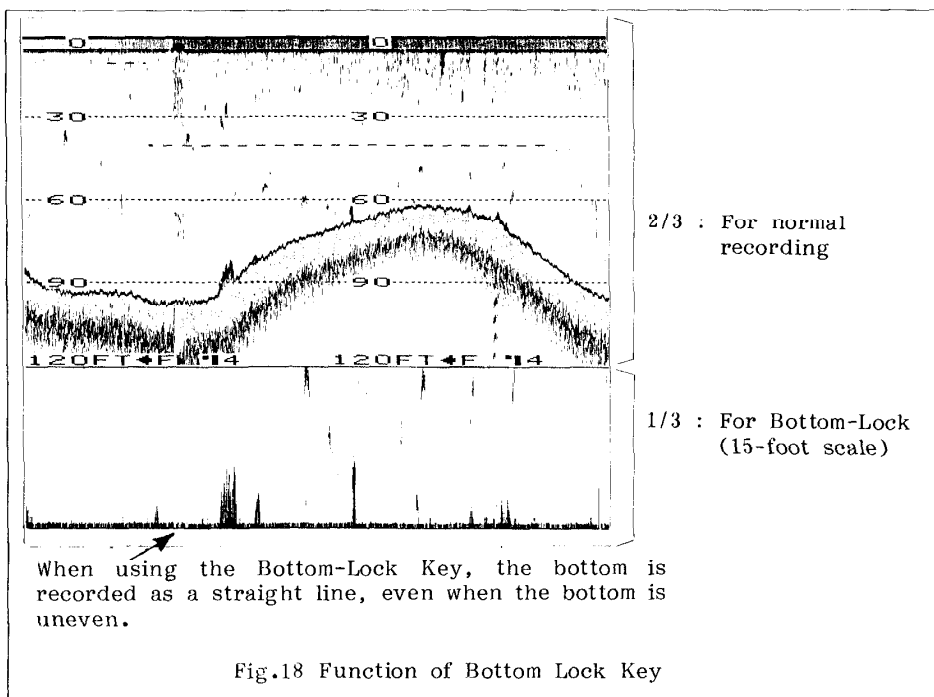



Range Marker Key: 

This key may be used to print range markers on the recording paper. The interval of the markers is determined by the Basic and Phased Ranges in use. If these marks interfere with echoes you want to see, press the Range Marker key again to eliminate the marks.

Paper Illumination Key: 

This key provides background illumination for the recording paper. To illuminate the recording paper, press the key. To turn off the illumination lamp, press the key again.

Stand-by Key: 

When you would like to use the sounder as a simple depth indicator or stop advancement of the recording paper, press the stand-by key. Belt rotation and paper winding stop, but depth is indicated in the LCD window.  appears at the top of the LCD window when activated. Note that depth indication is provided only when the bottom echo can be detected in the range in use.

INDICATORS

The following page summarizes all the various indicators that are shown in the LCD window and on a typical recording paper.

IN THE LCD WINDOW

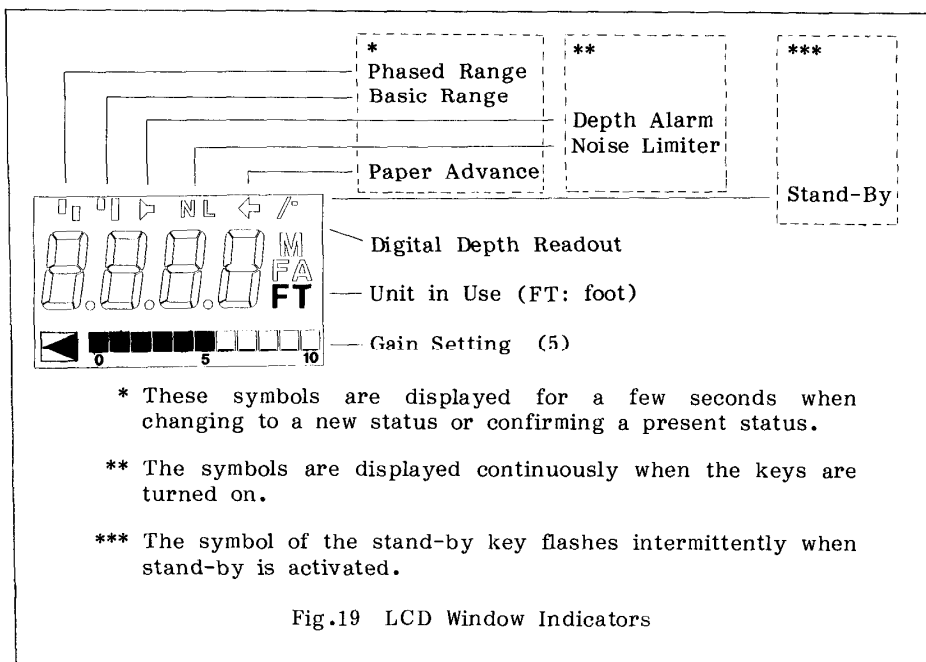

Digital Depth Readout

This indicator shows the depth from the transducer to the bottom. The unit is capable of reading depths beginning from 3 feet below the transducer. This minimum depth limitation is necessary to prevent locking onto surface turbulence rather than the bottom. Note that depth readout continues even when the stand-by switch is set to "ON." Apart from the above normal readout, the selected basic range, phased value (if used) and the Depth Alarm setting can be confirmed by pressing the key corresponding to the setting you wish to check. The readouts last for a few seconds, then revert to depth readout.

Unit in Use

This indicator shows the unit of measurement (meters, feet or fathoms) used for the depth readout. The units are abbreviated on the LCD as follows: meters (M), fathoms (FA) and feet (FT). Again, the units of measurement are determined by a jumper block inside the cabinet. See page 36.

Gain Setting in Use

The receiver gain setting presently selected is displayed with rectangular blocks, in 10 steps.

Phased Range, Basic Range and Paper Advance Speed

Only the symbols are indicated for a few seconds when changing to a new status as well as confirming the present status.

Depth Alarm

When the alarm is set, a ∇ symbol appears at the top of the LCD window.

Noise Limiter

An "NL" symbol appears at the top of the window where the Noise Limiter is being used.

Stand-By

A \swarrow symbol flashes intermittently when the stand-by key is turned on.

ON THE RECORDING PAPER

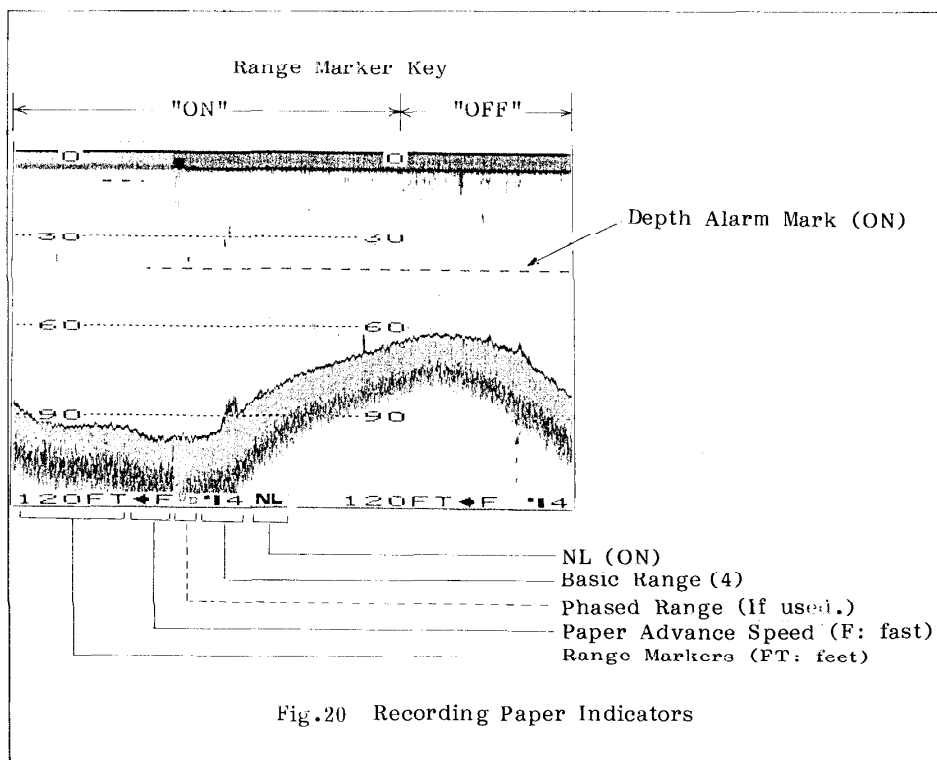

Range Markers

These are the range calibration marks and are determined by the Basic and the Phased Range's in use.

Paper Advance Speed

The presently selected advance speed (S, M or F) and its symbol  are printed on the lower part of the paper.

Basic Range

The selected range (1-7) appears to the right of the  symbol.

Phased Range

When the Phased Range is used, the Phased Range symbol  appears, however the phased value is not indicated.

NL

An "NL" symbol appears when the Noise Limiter is being used.

Depth Alarm Mark

When the Depth Alarm is being used, a dashed line marks the depth set by the alarm.

INTERPRETING THE RECORDING

As mentioned before both fish echoes and bottom contour echoes are composed of a series of vertical scan lines moving right to left across the recording paper. It is possible for the same object to be recorded in a variety of shapes depending on the distance to the object, the angle at which the fish is struck by the transmitted pulse, echo strength, etc.

DETECTING AREA

The detecting area varies depending on the main beamwidth of the transducer, as shown below. Objects out of the main beam but close to the beam will be presented less densely, smaller in size, and at a lower intensity.

With the FE-4300, the operator has the choice of either 50kHz or 200kHz transducer operation. Each frequency requires a different recorder unit and transducer. There are advantages and disadvantages to both frequencies and you should select the frequency best suited to your needs.

Generally, beamwidth depends on transmission frequency; a narrower beamwidth is usually obtained at the higher frequency (200kHz). For example, the 200B-5NR 200 KHz transducer has a "-3 dB" beamwidth of 10 degrees, whereas the 50B-5NR 50 KHz transducer has a beamwidth of 46 degrees.

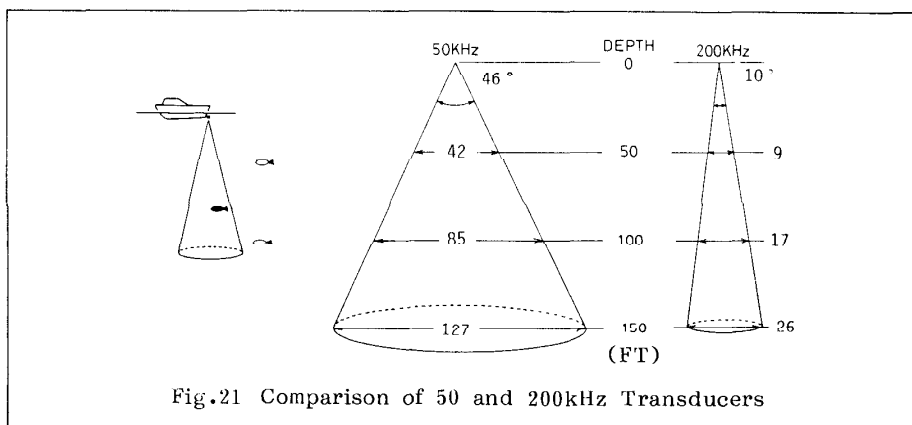

Because the beamwidth of the 200kHz transducer is narrow, the operator has the advantage of higher resolution. In addition, the effects of cruising noise and air bubbles are greatly reduced, since air bubbles resonate at frequencies between 15 and 100kHz. On the minus side, a narrow beamwidth transducer will record even the smoothest bottom contour in a sawtooth pattern if the boat is moving up and down due to pitching and rolling of the boat.

This makes discrimination of fish down close to the bottom difficult. Also, because of the limited coverage area, a narrow beamwidth tends to overlook catchable fish at the sides of the boat. (The maximum percent of depth covered on the bottom for a 200B-5NR is 17% of the depth. For example, if the bottom depth is 300 feet, the diameter of the coverage circle on the bottom would be only 51 feet.)

One of the advantages in employing a wider-beam lower frequency transducer (50kHz) is that it allows you to see those catchable fish at the sides of your boat. For example, the 50B-5NR transducer can see a circle whose diameter is 85% of the depth. At 300 feet, this means the 50B-5NR would see a circle of 255 feet diameter.

In addition, low frequency ultrasonic waves can travel further than higher frequency ones, resulting in a greater depth sounding range. On the negative side, a wide beamwidth lowers the resolution capability, and the recording is more susceptible to the effects of cruising noise and air bubbles.

ZERO LINE

The zero line (sometimes referred to as the transmission line) represents the transducer's position, and moves off the recording paper when a phased range is used. See fig.22.

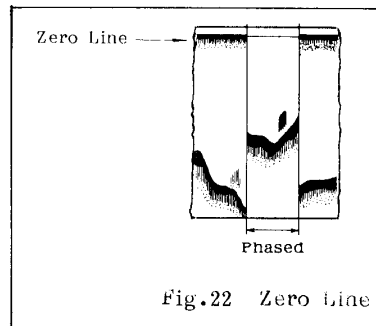

FISH SCHOOL ECHOES

Fish school echoes will generally be plotted between the zero line and the bottom. Usually the fish school/fish echo is weaker than the bottom echo because the reflection surface and the reflection property are much smaller than compared to the bottom. The size of the fish school can be ascertained from the intensity of the recording. See fig.23.

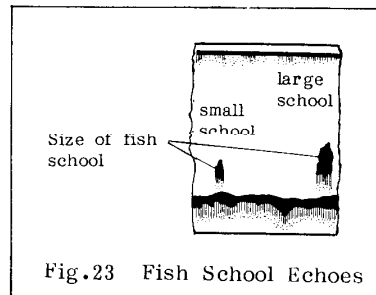

BOTTOM ECHO

Echoes from the bottom are normally the strongest and are recorded in the highest intensity, but intensity and width will vary with bottom composition, water depth, frequency, sensitivity, etc.

In a comparatively shallow depth, a high gain setting and a strong bottom echo will cause a second or sometimes a third or a fourth echo to be recorded at the same interval between them below the first echo trace. This is because the echo travels between the bottom and the surface twice or more in shallow depths.

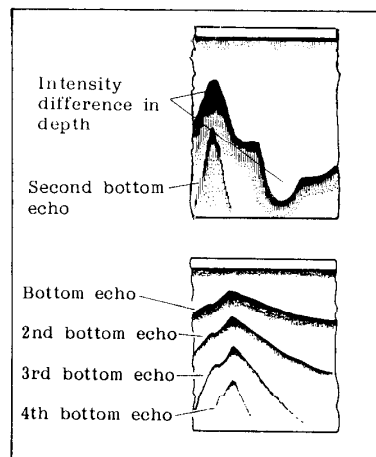

The width of the bottom echo can be used to help determine the density of the bottom material (soft or hard). The harder the bottom, the wider the trace. If the gain is set to show only a single bottom echo on mud, a rock bottom will show a second or third bottom return. The Basic Range chosen should be set to show the first and second bottom echoes when bottom hardness is being determined.

In rough waters the bottom is recorded in a zig-zag pattern, similar to the teeth of a saw. This is caused by the heavy pitching and rolling of the boat, causing the sounding direction to fluctuate and the distance to the bottom to vary. See fig.24.

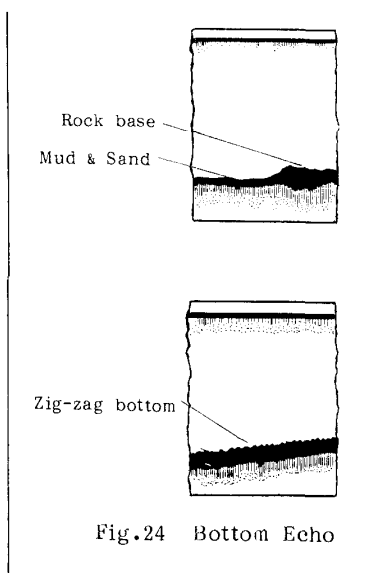

SURFACE NOISE/AERATION

When the waters are rough or the boat passes over a wake, surface noise may appear near the zero line. As surface turbulence is acoustically equivalent to running into a brick wall, the bottom echo will be recorded intermittently. Similar noise sometimes appears when a water temperature difference (thermocline) exists. Different species of fish tend to prefer different temperature zones, so thermocline information may be useful to help identify target fish. 200kHz tends to show shallow thermoclines better than 50kHz.

In rough waters the recording is occasionally interrupted due to below-the-ship air bubbles obstructing the sound path. This also occurs when the boat makes a quick turn or reverses movement. Lowering the paper advance speed may reduce the interruption. However, reconsideration of the transducer installation may be necessary if the interruption occurs frequently. See fig.25.

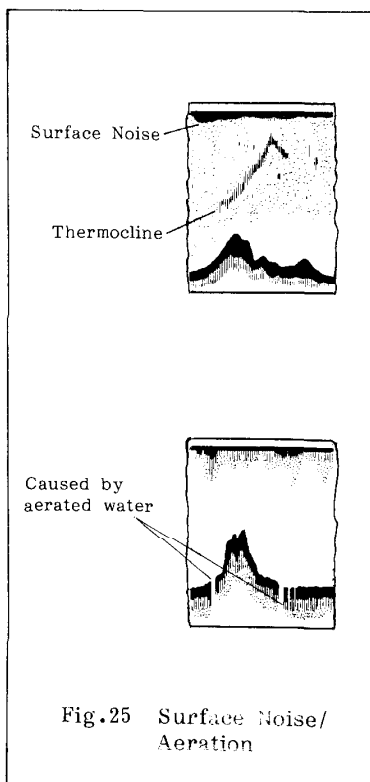

FUSE REPLACEMENT

To protect the equipment from serious damage, a fuse is provided on the rear panel, as illustrated in fig.27. The fuse protects against overvoltage/reverse polarity of the ship's mains or internal fault of the equipment. If the fuse has blown, first find the cause of the problem before replacing it with a new one. A fuse rated for more than 2A should not be used, since it may cause serious damage to the equipment.

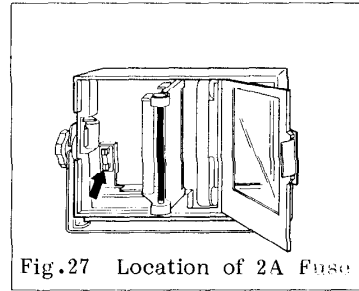

Fig.27 Location of 2A Fuse

CLEANING AND LUBRICATION

As dry recording paper is employed in this unit, it suffers from the disadvantage of creating a lot of carbon dust and giving off an unpleasant odor. Keep the equipment clean and dry at all times. Dust or loose dirt should be wiped off with a supplied sponge brush (see fig.28). To remove heavy dirt, use mild detergent and water on a cotton tipped swab or soft cloth. When cleaning the LCD window be careful not to apply undue pressure.

CAUTION

Never apply plastic solvent, such as thinner or acetone, for cleaning and lubrication. It may dissolve paint coating/markings on the front panel.

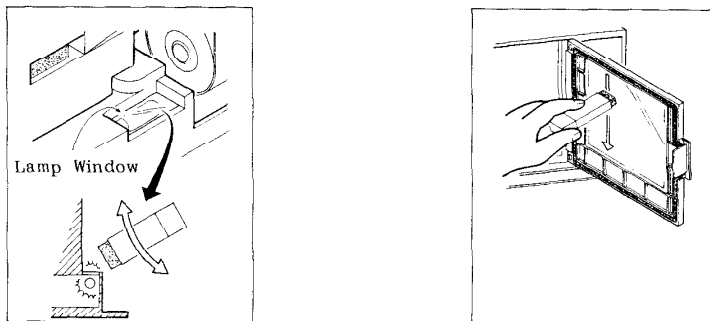

Fig.28 Method of Cleaning the Unit

MAINTENANCE OF THE TRANSDUCER

Underwater growth on the transducer face will result in a gradual decrease in the sensitivity. Check the transducer face each time the boat is drydocked. If any barnacles or seaweed growth is found, remove them very carefully with a piece of wood or sandpaper, taking care not to damage the transducer face.

TROUBLESHOOTING

In this section, troubleshooting is arranged in two parts: one for the user and the other for the service shop. "Basic troubleshooting for user" includes simple tests of the equipment which the user can handle, such as operation, installation and visual checks. The "More extensive troubleshooting for the service shop" is considerably more complicated and must be done by a qualified serviceman. If something appears wrong with your unit, check the equipment referring to the "Basic troubleshooting for user." In case the trouble isn't found after performing these checks, and the unit still appears faulty, call your electronics technician for service.

BASIC TROUBLESHOOTING FOR USER

- ◆ **Not working at all** —————
 - * Is the battery dead?
 - * Is the fuse blown?
 Supply voltage is normal?
 - * Corrosion on battery terminal?
 - * Poor contact of power cable?

- ◆ **No echo but range calibration mark shows** ————— * Transducer plug is loose?

- ◆ **Echo appears but no zero line** ————— * Is the range phasing operative?

- ◆ **Low sensitivity** —————
 - * Is the GAIN setting too low?
 - * Air bubble or underwater growth (barnacle, seaweed, etc.) attached to the transducer face?
 - * Highly sedimented water?
 - * Soft bottom?
 - * Is stylus-pressure normal?

- ◆ **Heavy noise or interference** —————
 - * Is the transducer located too near the engine?
 - * Is the unit grounded?
 - * Are other echo sounders of the same frequency operating nearby?

- ◆ **No water depth readout** —————
 - * Bottom echo is not recorded in black level?
 - * Bottom echo is not recorded on the paper?

MORE EXTENSIVE TROUBLESHOOTING FOR SERVICE SHOP

The FE-4300 incorporates diagnostic self-check facilities, enabling a service technician to find faulty components and/or board. If no trouble is found thru the "Basic troubleshooting for user," perform the following self-check. The test circuit checks 1) LCD module/display, 2) Static RAM (8k x 8) U8, 3) Recorder output and 4) Keyboard operation successively.

How to initiate self-check and read results

Turn on Power switch while depressing either the Gain, Phased or Basic Range touchpad. To stop the self-check, turn off the Power switch.

LCD module/display

After initiating, all symbols, numbers and units on the LCD are displayed with a beep sound in the following sequence.

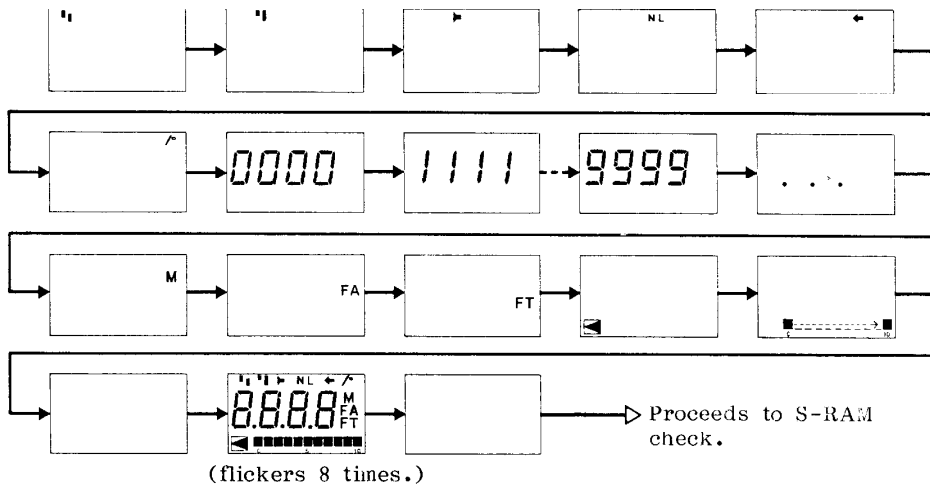

S-RAM Check

After LCD module/display check, S-RAM check starts and the result is indicated as either "0" or "1".



Recorder Output

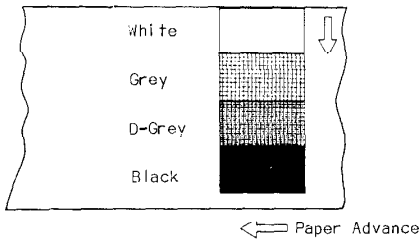

After S-RAM check, the recording belt starts to rotate and an echo intensity bar is printed in four steps on the recording paper. Through this check paper loading condition and stylus pressure can be also checked.

Keyboard Operation

In parallel with the recorder output check, the status of the keyboard operation is tested as follows. Press each touchpad for checking.

Symbol and "0" or "1" are indicated in the third figure of numeral display.

When depressing left side touchpads.
 (Results of S-RAM check)
 When depressing right side touchpads.

Only the symbol mark is displayed in the LCD window.
 (EX.)

Using the third and fourth figures of display, the following indications are shown.

	≡≡	(symbol)
	LI	(Light)
	bl	(bottom Lock)
	SL	(Shadow Line)

(EX.)

(Shadow Line) is switched on.

Troubleshooting by self-check

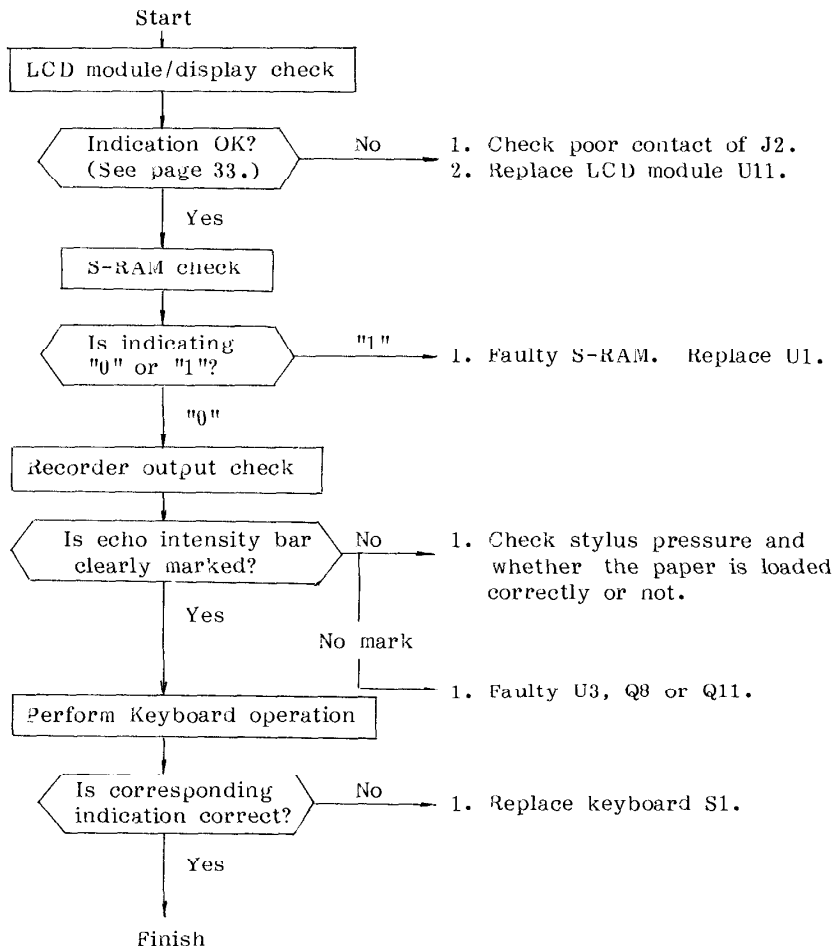

Check Guide for troubleshooting

The built-in CPU is initiated by the trigger pulse from the trig. sense board. Therefore the check of the electric circuit should be started from the generation of the trigger pulse as well as from the power supply voltage. This is easily performed by measuring the High and Low levels (0 - 5V) with a multimeter. But note that troubleshooting is based on board exchange.

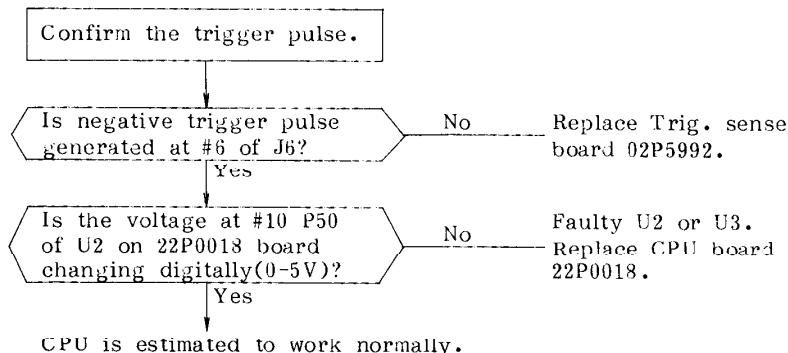

No Recording on the paper

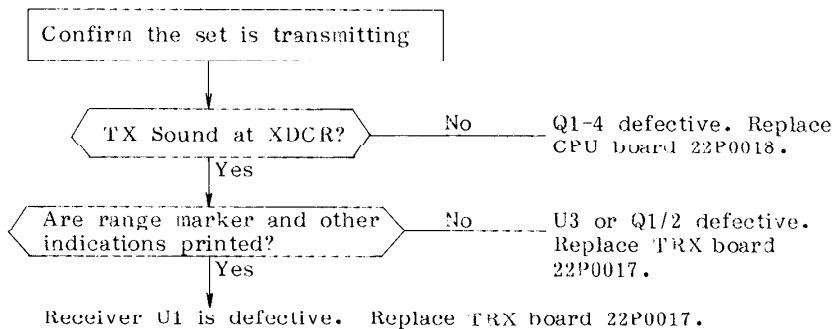

Keyboard is inoperative

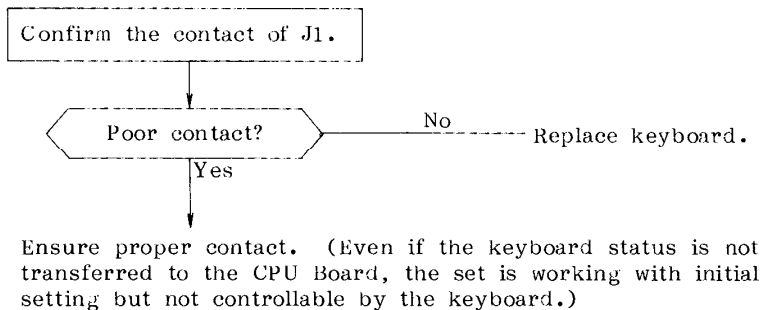

Belt drive motor doesn't rotate.

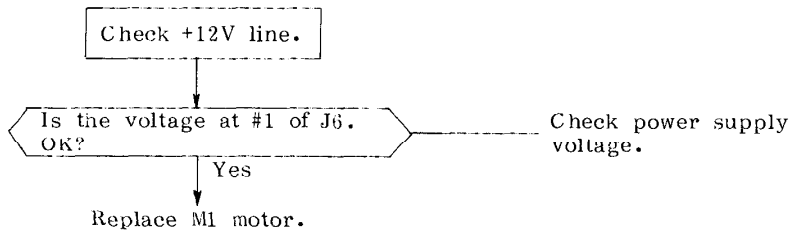

Paper does not advance.

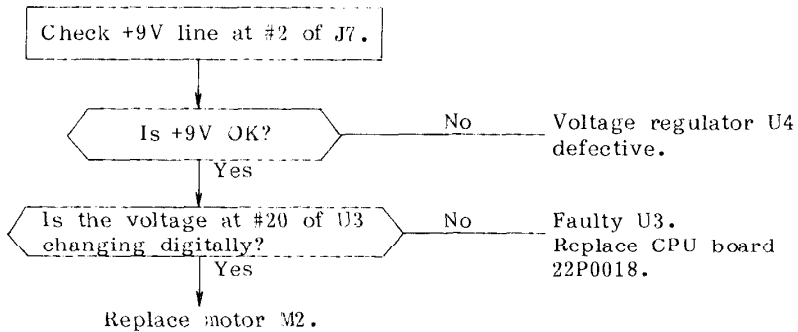

TRANSDUCER CHECK

A simple and reliable check of the transducer is to temporarily substitute a new transducer instead of the existing one to the Recorder Unit. If the recording sensitivity is considerably improved through this exchange, the transducer is considered to be faulty. On the contrary, if no differences are found, the Recorder Unit may be faulty. This method is especially useful for inside-hull or through-hull installation.

The following quick check also helps to judge the performance of the transducer to some extent.

Haul the transducer from the water and turn on the POWER. Put your ear near the transducer face and carefully listen to the transmission sound. If you can hear a clicking sound, the transducer probably is OK. Next, rub the transducer face with your hand and observe whether any noise appears on the recording paper. The appearance of noise indicates that the transducer is normal. In case of neither sound nor noise, the transducer is likely to be faulty.

HOW TO CHANGE INTERNAL SETTING

CHANGE OF DEPTH MEASUREMENT UNIT

A jumper block is provided on the CPU board to allow custom tailoring of the unit to specific uses, such as fishing method, fishing ground, etc. To change the setting; (1) turn off the POWER, (2) remove the rear cover and (3) move the jumper block with a needle-nose pliers as shown in fig.29.

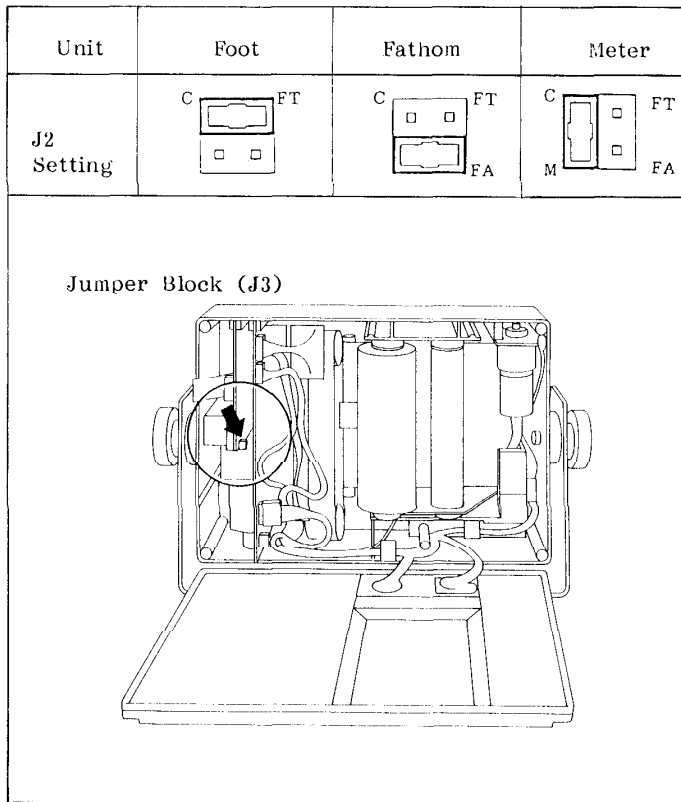
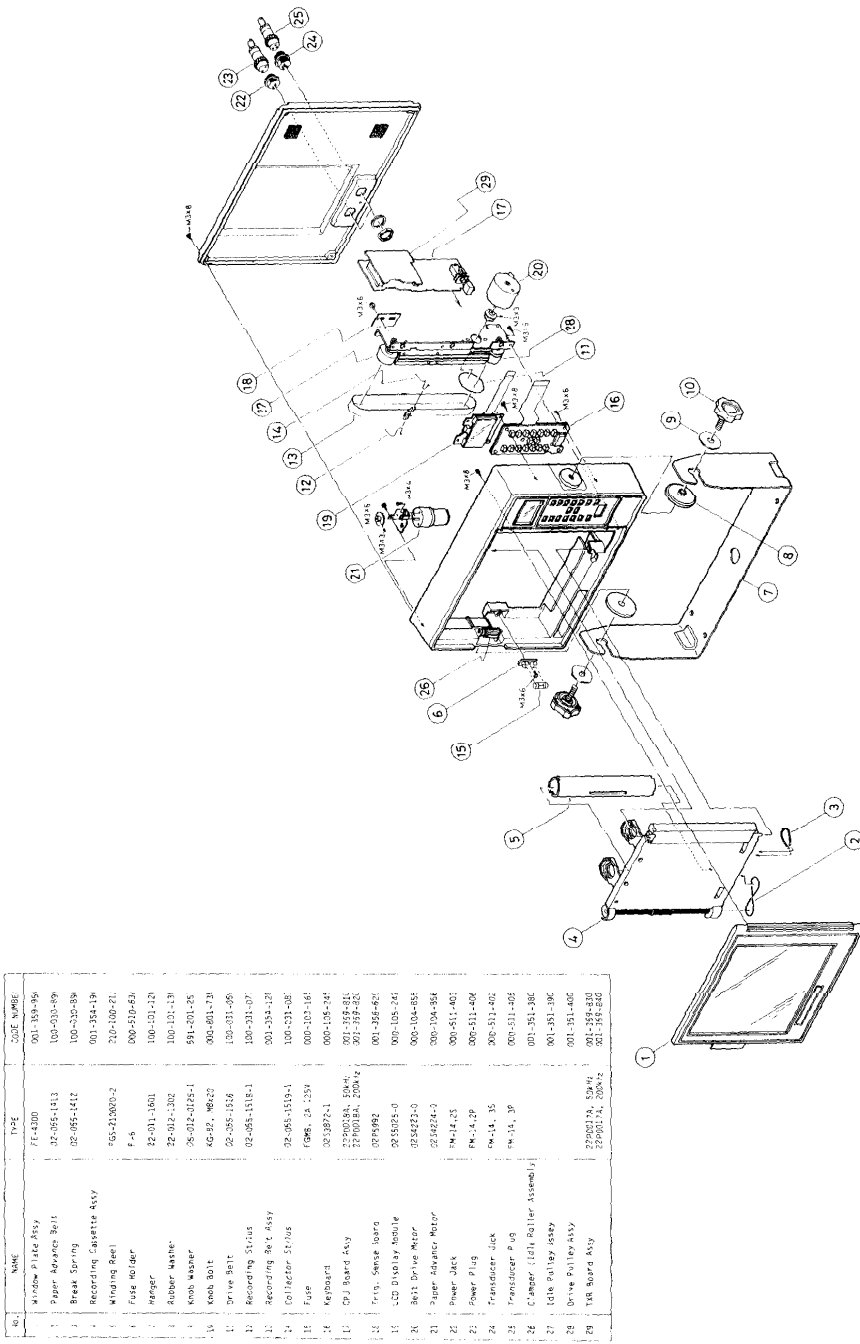

Fig.29 Location of Jumper Block Used for Changing Specifications



EXPLODED VIEW AND PARTS LIST

NO.	NAME	TYPE	CODE NUMBER
1	Window-Plate Assy	FC-4300	001-159-956
2	Paper Advance Belt	02-051-1413	100-030-859
3	Break Spring	02-055-1412	100-030-859
4	Recording Cassette Assy	001-354-159	001-354-159
5	Winding Reel	001-100-201	200-100-201
6	Reel Holder	F-5	000-510-653
7	Washer	22-501-1601	100-101-119
8	Rubber Washer	22-912-1302	100-101-119
9	Wood Washer	26-912-0125-1	591-201-25
10	Wash Bolt	65-02-0620	000-801-239
11	Drive Belt	02-055-1516	100-031-097
12	Recording Stylus	02-055-1515-1	001-354-121
13	Recording Reel Assy	02-055-1515-1	100-031-087
14	Collector Stylus	FORM. 24, 25A	000-100-161
15	Case	023397-1	000-106-341
16	Keyboard	22900384, 23040, 27000384, 23042	001-358-815 001-358-815 001-358-821
17	Tris. Sense Reels	0239982	001-356-621
18	Tris. Sense Reels	0235023-0	000-106-241
19	LED Drive Motor	0234223-0	000-104-855
20	Reel Drive Motor	0234223-0	000-104-855
21	Paper Advance Motor	0234224-0	000-104-856
22	Power Jack	74-14-25	000-511-401
23	Power Plug	FM-4, 2P	000-511-404
24	Transducer Plug	FM-14, 3S	000-511-402
25	Transducer Plug	FM-14, 3P	000-511-405
26	Changer (10) Reel Assembly		001-351-396
27	Drive Pulley Assy	22900179, 52940, 22900174, 23042	001-351-400 001-358-830 001-358-840
28	VR Board Assy		001-358-840

APPENDIX

ADJUSTMENT OF RECORDING STYLUS PRESSURE

The pressure of the recording stylus (contact force of the stylus to the recording paper) largely affects the recording quality. Whenever the recording stylus is replaced, follow the procedure below.

[PROCEDURE]

- 1) Confirm that the angle of the collector stylus is within 50 -60 degrees before mounting it onto the holder.

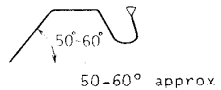

- 2) Adjust the angle of the recording stylus to approximately 60 degrees as shown below. When the stylus is mounted onto the holder, it comes in contact with the recording paper at approximately 45 degrees.

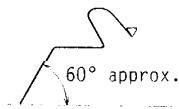

(a) Off the holder

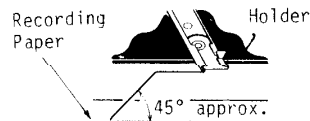

(b) On the holder

* For Reference

If the "D" (figure below) is 2 - 4mm from the lower edge of the recording paper when the nib of the recording stylus is just off the recording plate, the stylus pressure (bending angle) is set in good condition.

Note: The Collector stylus should also be adjusted as started in step 1).

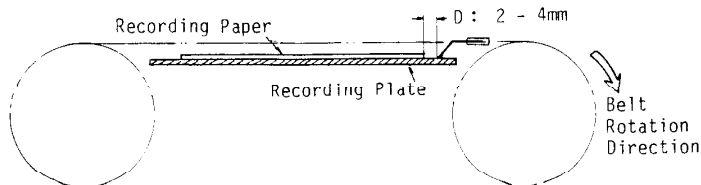

Free Manuals Download Website

<http://myh66.com>

<http://usermanuals.us>

<http://www.somanuals.com>

<http://www.4manuals.cc>

<http://www.manual-lib.com>

<http://www.404manual.com>

<http://www.luxmanual.com>

<http://aubethermostatmanual.com>

Golf course search by state

<http://golfingnear.com>

Email search by domain

<http://emailbydomain.com>

Auto manuals search

<http://auto.somanuals.com>

TV manuals search

<http://tv.somanuals.com>