

FURUNO

OPERATOR'S MANUAL

150W SSB RADIOTELEPHONE

MODEL FS-1501

This manual is applicable to the sets
having new ITU frequencies.



FURUNO ELECTRIC CO., LTD.
NISHINOMIYA, JAPAN

©FURUNO ELECTRIC CO., LTD.

9-52, Ashihara-cho,
Nishinomiya, Japan 662

Telephone: 0798-65-2111
Telefax: 0798-65-4200

Your Local Agent/Dealer

All rights reserved. Printed in Japan

FIRST EDITION : APR 1988
M : JUL. 15, 1993

(MAOS)

PUB. No. OME-54851
FS-1501



A WORD TO FS-1501 OWNERS

Congratulations on your choice of the Furuno FS-1501 HF SSB RADIOTELEPHONE! We are confident that you will enjoy years of comfortable operation with this fine piece of equipment.

For over 40 years Furuno Electric Company has enjoyed an enviable reputation for quality and reliability throughout the world. This dedication to excellence is furthered by our extensive global network of agents and dealers.

The FS-1501 is just one of the many Furuno developments in the field of radio communications. The compact, light-weight but rugged unit is easy to install and operate and is suitable for marine, landmobile and point-to-point communications.

In addition to Furuno's proven seaworthiness, your FS-1501 is designed and constructed using the most advanced concepts and state-of-the-art engineering technology. Several custom chips are newly designed and incorporated to provide stable and reliable performance as a professional (yet affordable) communications equipment.

To obtain optimum performance from the unit, however, please read this operator's manual and follow the recommended procedures for installation, operation and maintenance. With proper care, your FS-1501 should provide many years of enjoyable and dependable communications.

Thank you for considering and purchasing Furuno product.

Anti-moisture measure

Ventilation must be provided to prevent moisture from being drawn into the enclosure during atmospheric pressure changes and to allow trapped humid air to escape. Two vent holes are provided on the unit (see figure below), one at the rear and one at the bottom, and one should be opened according to the installation method. If the coupler is installed horizontally, remove screw A and if vertically, remove screw B. If the coupler is installed outdoors, attach the vent tube (supplied) to prevent water leakage inside the coupler. *These measures should be done before mounting the unit. Refer to page D-2 for the outline of the antenna coupler.*

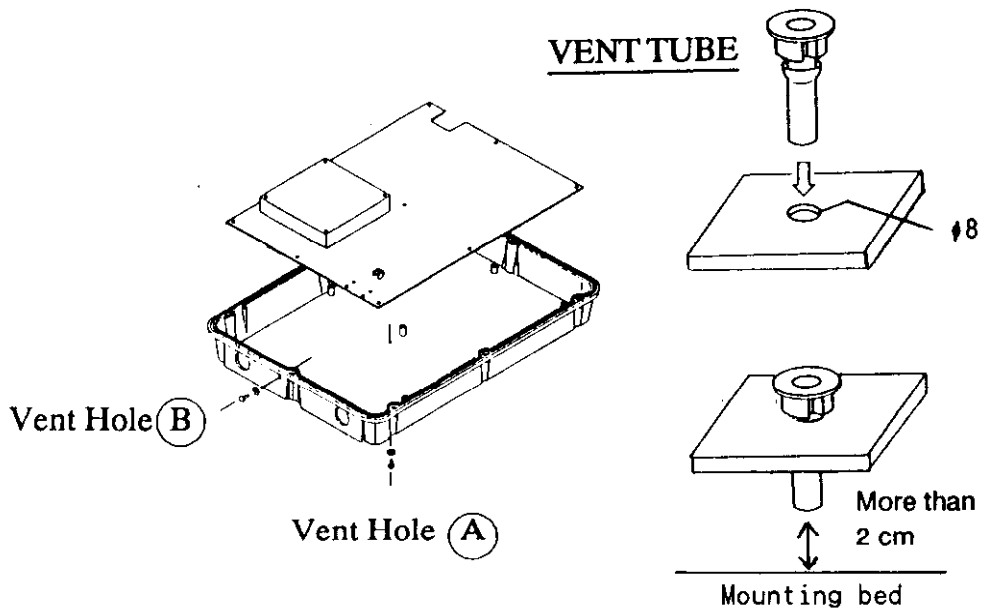

Location of vent holes and vent tube

■ NOTE: How to fix vent tube.

1. Dismount the p.c. board.
2. Enlarge the vent hole to dia. 8 mm.
3. Insert the vent tube from inside of the coupler.
4. Mount the p.c. board.
5. Before fixing the coupler, confirm that the space between mounting bed of antenna coupler and the tip of the tube is at least 2 cm. If not, water may leak into the coupler.

*** * * C O N T E N T S * * ***

	Page
SPECIFICATIONS	-1-
COMPLETE SET	-4-
GENERAL	-6-
FEATURES	-7-
OPERATING PRECAUTIONS	-9-
CHAPTER 1 OPERATION	1-1 thru 1-15
1.1 Description of Front Panel Control	1-1
1.2 Turning ON/OFF the Power	1-3
1.3 Adjusting the Dimmer	1-3
1.4 Turning ON/OFF the loudspeaker	1-4
1.5 Selection of Frequency	1-4
User Channel Mode	1-4
Free Frequency Mode	1-5
ITU Channel Mode	1-6
1.6 Selecting the Emission Mode	1-7
1.7 Adjusting the Volume	1-7
1.8 Commencing Communication	1-7
Watch on the Desired Frequency	1-7
Antenna Tuning	1-7
Communication	1-8
Communication Using VOX	1-8
Monitoring Transmission	1-8
Monitoring Receiving Signal Strength	1-9
1.9 Clarifying the Received Signal	1-9
1.10 Transmission of Two-Tone Alarm	1-9
1.11 Reduction of Transmission Power	1-10
1.12 Turning ON/OFF the Squelch	1-10
1.13 Channel Programming	1-10
1.14 Scanning Reception	1-13
1.15 In the Event of Coupler Failure	1-14
CHAPTER 2 MAINTENANCE	2-1 thru 2-3
2.1 General	2-1
2.2 Fuse Replacement	2-3
2.3 Cleaning	2-3
CHAPTER 3 MINOR TROUBLESHOOTING	3-1 thru 3-3
3.1 Trouble Finding List	3-1
3.2 Self-test	3-3
Check of Relay	3-3

CHAPTER 4	PARTS LOCATION	4-1 thru 4-2
4.1	Transceiver Unit	4-1
4.2	Antenna Coupler Unit	4-2
CHAPTER 5	INSTALLATION	5-1 thru 5-19
5.1	General Notes on Installation	5-1
5.2	The Antenna	5-2
5.3	The Ground	5-5
5.4	Antenna Coupler Installation	5-7
5.5	Mounting Transceiver	5-12
5.6	Cable Connection	5-13
5.7	Wiring	5-14
5.8	Post Installation Check	5-16
5.9	Manual 2182kHz Setting	5-18
5.10	Installation of VOX IC	5-19
OUTLINE DRAWINGS		D-1 thru D-3
INTERCONNECTION DIAGRAM		D-4
SCHEMATIC DIAGRAMS		S-1 thru S-9
APPENDIX-A	Specification Of Control Cable	APA-1
APPENDIX-B	User Channel List	APB-1 and APB-2
APPENDIX-C	Connection of Telex Terminal	APC-1 thru APC-3
APPENDIX-D	Distress Calling Procedure	APD-1
APPENDIX-E	Notes for Flush Mount Installation for FS-1501	APE-1
FREQUENCY LIST FOR ITU CHANNELS		LIST-1

SPECIFICATIONS OF FS-1501

GENERAL

Communication System	Simplex or semi-duplex
Frequency Range	1.6 to 23MHz
Type of Oscillation	10Hz resolution PLL synthesizer
Class of Emission	J3E: (USB/LSB) R3E: (USB with pilot carrier) H3E: (AM Compatible) F1B: (Radioteletype) A1A: (Telegraph)
Number of Channels	1) Free synthesis in 10Hz resolution 2) User preset 64 semi-multiplex or 128 simplex channels 3) Factory Preset 324 ITU SSB channels 4) Factory Preset 746 ITU TELEX channels 5) 2182kHz(J3E, single action)
Frequency Stability	Better than ± 20 Hz at -20°C to $+55^{\circ}\text{C}$ (After 15 minutes warm up)
Ambient Temperature Range	-20°C to $+55^{\circ}\text{C}$
Power Supply and Power Consumption	12VDC $-10/+30\%$ (Nominal 13.6V) Receiving 1.2A Transmit 18A(peak 30A) CW(keyed) 20A
Frequency Selection	Touchpad Key and/or Dial Encoder
Dimmer	Illumination for touchpad key panel and LCD panel (4 steps)
Display	Channel number, Frequency, Class of emission, Status of controls, Signal strength, Antenna current or 50 ohm output line current
I/O Connections	Microphone, External Antenna Coupler, Telegraph key, Radioteletype terminal (option)

Coating Color Cabinet : 2.5GY 5/1.5
 Front Panel : N-3.0

Dimensions and Weight 100mm x 250mm x 280mm (3.9" x 8.9" x 11.0")
 5.8kg (12.81bs.)

RECEIVER

Receiving System Double conversion superheterodyne
 IF : 54.455MHz and 455kHz

Sensitivity Input level to produce SINAD 20dB
 J3E/R3E: 6dBuV
 H3E : 20dBuV

Selectivity 2.4kHz at -6dB (J3E)
 4.5kHz at -60dB (J3E)

Audio Output Internal speaker: 1W
 External 4 ohm speaker: 5W max.
 Handset: 50mW

Controls Fine tuning by dial, Squelch ON/OFF, Scanning
 ON/OFF, Speaker ON/OFF, Volume control

TRANSMITTER

Output Impedance 50 ohms

RF Output Power J3E/R3E 150Wpep
 H3E 37.5W
 F1B/A1A 75W
 TUNE 10W

Power Reduction Less than 60Wpep

Controls Output HI/LOW, Test/send of Two-tone Alarm
 Generator, 2182kHz single action key

ANTENNA COUPLER (AT-1500)

Tuning System	CPU controlled fully automatic tuning system
Frequency Range	1.6 to 25MHz
Input Impedance	50 ohms
Antenna Required	6 to 15m wire or whip
Power Capability	150Wpep, 75W continuous
Tuning Power	10 W
VSWR	less than 1.5
Tune-up Time	Within 2 to 15 sec. Within 0.5 sec. in the pretuned bands
Switches/Controls	MANUAL 2182kHz tuning facility TEST switch (Self-test)
Power Requirement	15VDC (supplied from transceiver), 0.6A max.
Ambient Temperature	-30°C to +60°C at 95%RH
Construction	Weather-proof plastic cabinet, stainless steel mount
Coating Color	White
Dimensions	267mm (W) x 390mm (H) x 90mm (D) (10.5" x 15.4" x 3.5")
Weight	Approx. 2.9kg (6.4lbs.)

Complete Set

No.	NAME	TYPE	CODE No.	Q'TY	REMARKS
1	Transceiver Unit	FS-1501	000-055-186	1	
2	Antenna Coupler Unit	AT-1500	000-055-203	1	
3	Accessories For FS-1501	FP05-02000	000-055-200	} 1 set	
		FP05-02010	000-055-201		
		FP05-02020	000-055-202		
	For AT-1500	FP05-02100	000-055-205	1 set	
3	Spare Parts	SP05-02100	000-055-188	1 set	
4	Installation Materials For FS-1501	CP05-02700	000-055-189	1 set	
	For AT-1500	CP05-02800	000-055-204	1 set	
5	Control Cable	05S0463 (10m)	000-113-355	} 1 set	Standard 10m. Specify if longer cable is required
		(20m)	000-113-356		
		(30m)	000-113-357		
		(40m)	000-113-358		
		(50m)	000-113-359		
6	Coaxial Cable	05S0462 (10m)	000-113-360	} 1 set	
		(20m)	000-113-361		
		(30m)	000-113-362		
		(40m)	000-113-363		
		(50m)	000-113-364		
7	Antenna Materials			(1 set)	
8	AC Power Supply	PR-270	000-113-349	(1 set)	
9	DC-DC Convertor	PC-220	000-113-350	(1 set)	
10	External Speaker	HCB100D	000-113-352	(1)	
11	Telegraph Key	HK707	000-589-102	(1)	
12	VOX IC	OP05-11	005-922-970	(1)	
13	U-Bolt	OP05-12	005-923-680	(1 set)	
14	Telex Connection Kit	OP05-14	005-923-670	(1 set)	
15	Flush Mount Bracket	OP05-16	005-923-960	(1 set)	

* Items 7 to 15 are optional supply.

Accessories For Transceiver Unit

FP05-02000

No.	NAME	TYPE	CODE No.	Q'TY	REMARKS
1	Hanger	FP05-02001	005-922-690	1	
2	Accessories	FP05-02002	005-922-700	1 set	
3	Microphone	DM1620FZ1	000-112-622	1	

FP05-02010

No.	NAME	TYPE	CODE No.	Q'TY	REMARKS
1	Hanger	FP05-02001	005-922-690	1	
2	Accessories	FP05-02002	005-922-700	1 set	
3	Handset	HS-6000FZ5	000-112-623	1	
4	Handset Hanger	FP05-01311	005-011-950	1 set	

FP05-02020

No.	NAME	TYPE	CODE No.	Q'TY	REMARKS
1	Hanger	FP05-02001	005-922-690	1	
2	Accessories	FP05-02002	005-922-700	1	
3	Microphone (Noise Canceller Type)	M112D4509910	000-116-487	1	

Accessories For Antenna Coupler EP05-02100

No.	NAME	TYPE	CODE No.	Q'TY	REMARKS
1	Pipe Seal	12W-R	000-113-354	1	

Spare Parts SP05-02100

No.	NAME	TYPE	CODE No.	Q'TY	REMARKS
1	Fuse	FGBO 30A 125VAC	000-549-017	2	

Installation Materials For Transceiver Unit CP05-02700

No.	NAME	TYPE	CODE No.	Q'TY	REMARKS
1	US Plug	PJ-2240-P	000-120-961	2	
2	Connector Cover	05S4426	000-113-346	2	
3	Power Cable	05S0414	000-113-347	1	
4	Ground Cable	05S0479	000-113-348	1	2m

Installation Materials For Antenna Coupler CP05-02800

No.	NAME	TYPE	CODE No.	Q'TY	REMARKS
1	Tapping Screw	6x20 SUS304	000-800-414	4	
2	Flat Washer	M6 SUS304	000-864-129	4	
3	Ground Cable	05S0479	000-113-348	1	2m

Antenna Materials

No.	NAME	TYPE	CODE No.	Q'TY	REMARKS
1	Doublet Antenna Kit	E22	000-050-632	(1 set)	
2	Single Wire Antenna Kit	E24	000-050-634	(1 set)	
3	Double-span Antenna Kit	E25	000-050-635	(1 set)	
4	Whip Antenna Lead-in Kit	E26	000-050-636	(1 set)	
5	Whip Antenna Feeder Kit	E27	000-050-637	(1 set)	
6	6m Whip Antenna	FAW-6R2A	000-107-921	(1 set)	
7	6m Whip Antenna	FAW-6R2	000-572-108	(1 set)	

GENERAL

This very small 150W SSB radiotelephone is constructed by the latest radio engineering and MPU control technology. It is very simple to operate and all the information that is needed for communication is shown on the large LCD (Liquid Crystal Display).

The output of the transceiver is "50 ohms", so an Antenna Coupler is necessary when it is operated with many frequencies. The AT-1500 Antenna Coupler is designed specially for the FS-1500 series radiotelephone and it can "automatically tune" to the antenna (length 6 to 15m) without any adjustment.

The supplied power should be 12VDC nominal and 30A at the maximum. You can use it with 24 or 32VDC with the optional DC-DC converter, or 110 or 220VAC with the optional rectifier.

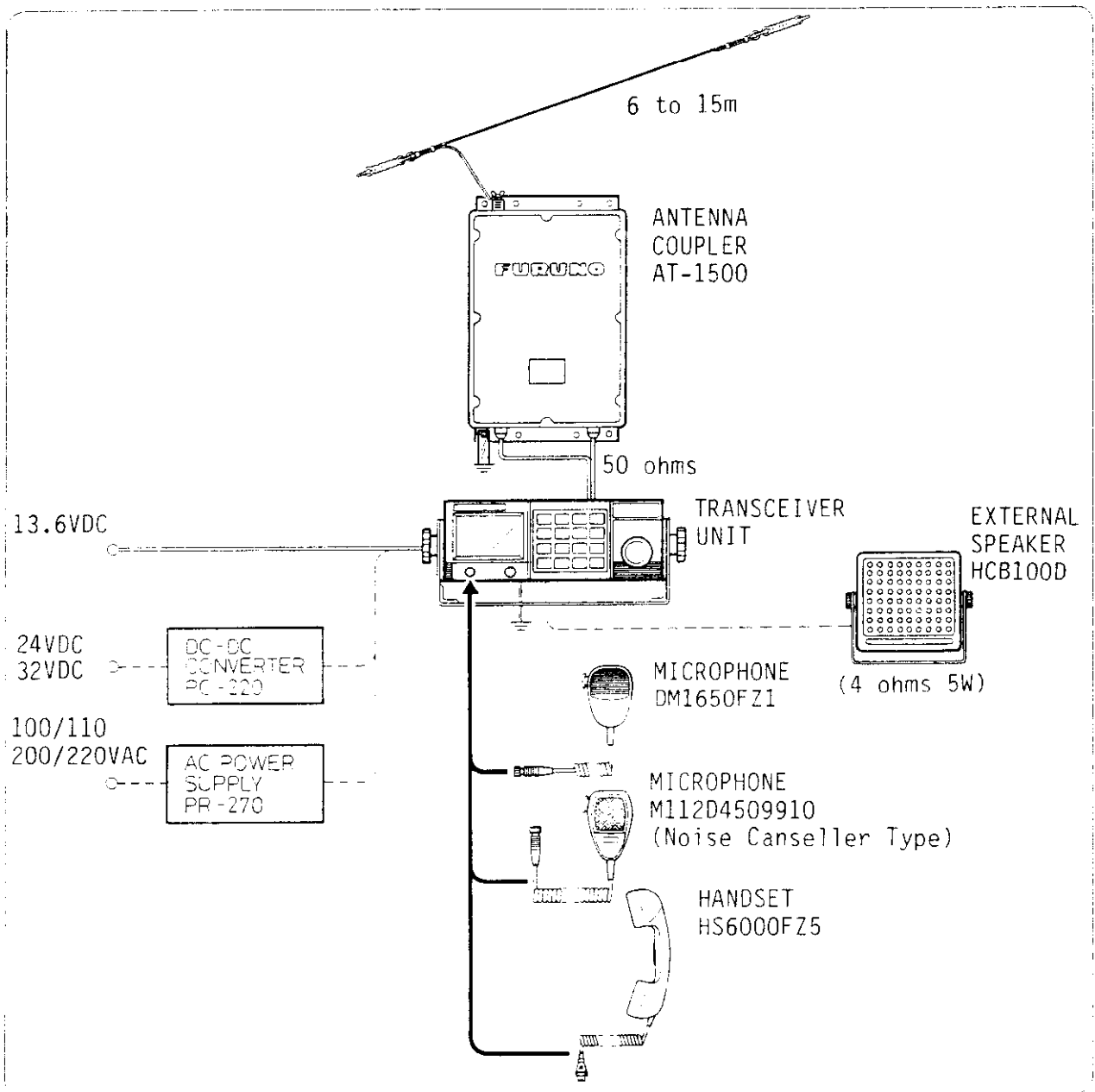

F E A T U R E S

DURABLE MECHANICAL AND ELECTRICAL DESIGN

The compact and light-weight but solid and rugged cabinet permits installation most anywhere. Heavy duty transmitter allows 24-hour continuous operation with minimum heat generation.

GENERAL COVERAGE IN 10Hz RESOLUTION

Capable of transmitting and receiving on all HF frequencies from 1.6MHz to 23MHz in 10Hz resolution. It works as a general coverage receiver from 1.6MHz to 23MHz for news broadcasts, weather facsimile, navigational warnings, etc.

324 ITU SSB CHANNELS PRE-PROGRAMMED

Pre-programmed 324 ITU (International Telecommunication Union) SSB channels and 746 ITU TELEX channels. Channels can easily recalled and modified.

64 (semi-duplex)/128 (simplex) USER CHANNEL MEMORY

Provided with pre-programmed memory, capable of storing 64 TX/RX frequency pairs with required class of emission.

USEFUL SCAN FUNCTION

Automatic scan function available on user channels.

LARGE EASY-TO-READ LCD DISPLAY

All necessary information is presented on large high-contrast LCD display. Adjustable back-light for the display and touchpad keys enables safe and comfortable operation for day and night.

FRIENDLY OPERATION

Allows frequency/channel selection in two ways; by direct touchpad input or by the rotary control.

SIMPLE EMERGENCY OPERATION

Independent [2182] key permits instantaneous selection of distress/calling frequency and class of emission. Also two-tone alarm generator is built-in to meet SOLAS requirements.

BUILT-IN NOISE BLANKER AND SQUELCH

Incorporated as standard with quick response noise blanker, effective both for narrow and wide pulses such as ignition noise. Switchable squelch control for comfortable reception.

VARIETY OF OPTIONS

Convenient options include;

- * Power Supply Units (Rectifier, DC-DC Converter)
- * Handset, Noise Canceller Microphone
- * VOX (Voice Operated Switch) for switching transmitting and receiver automatically by sensing speech
- * Telex Connection Kit for Telex Communication (required telex terminal: FURUNO Model DP-5 NBDP Terminal or Thrane-Thrane Model 1600 system)

OPERATING PRECAUTIONS

- 1) Prior to operating the equipment, a proper license and call sign must be released for the radio station.
- 2) This equipment must be operated only by a person holding a valid radio operator license or permit.
- 3) Although the equipment may be factory-programmed with any transmitting frequencies between 1.6MHz to 23MHz in 10Hz steps, the station licensee is always responsible for the lawful and proper operation of his station. FURUNO will assume no responsibility for any communication disturbance or inconvenience due to illegal transmission on unauthorized frequency range.
- 4) The radio wave is public property and it should be used in accordance with appropriate regulations. Do not transmit with too much power or when unnecessary it will interfere with other's communication.
- 5) The cabinet is also used as a part of a heat sink, so it will become warm after a long transmission. Allow for enough air circulation around the unit and never put anything on top of the cabinet.
- 6) Large amount of electric current are required for voice transmission by SSB radiotelephone. If the battery becomes discharged then the radiotelephone can't transmit in enough power. Keep the battery fully charged.
- 7) The antenna and its ground are important. If these are not in good condition, you can't expect optimum performance from the unit then more you will damage your equipment than you can't have a good communication.
- 8) Each time you begin transmission, your radio is tuned automatically to the antenna by the antenna coupler. However it can not tune when the antenna is broken or its CPU control circuit does not function properly. If you hear "beeps" at the beginning of each transmission, there may be something wrong with the antenna or the control circuit. In this case select 2182kHz, open the cover of the Coupler and turn the [MANUAL TUNE] switch to the "MANUAL 2182kHz" position. Tell your radio is in trouble while it is not during silent time (0 to 3, 15 to 18, 30 to 33, 45 to 48 minutes of every hour). But never use the two-tone alarm.

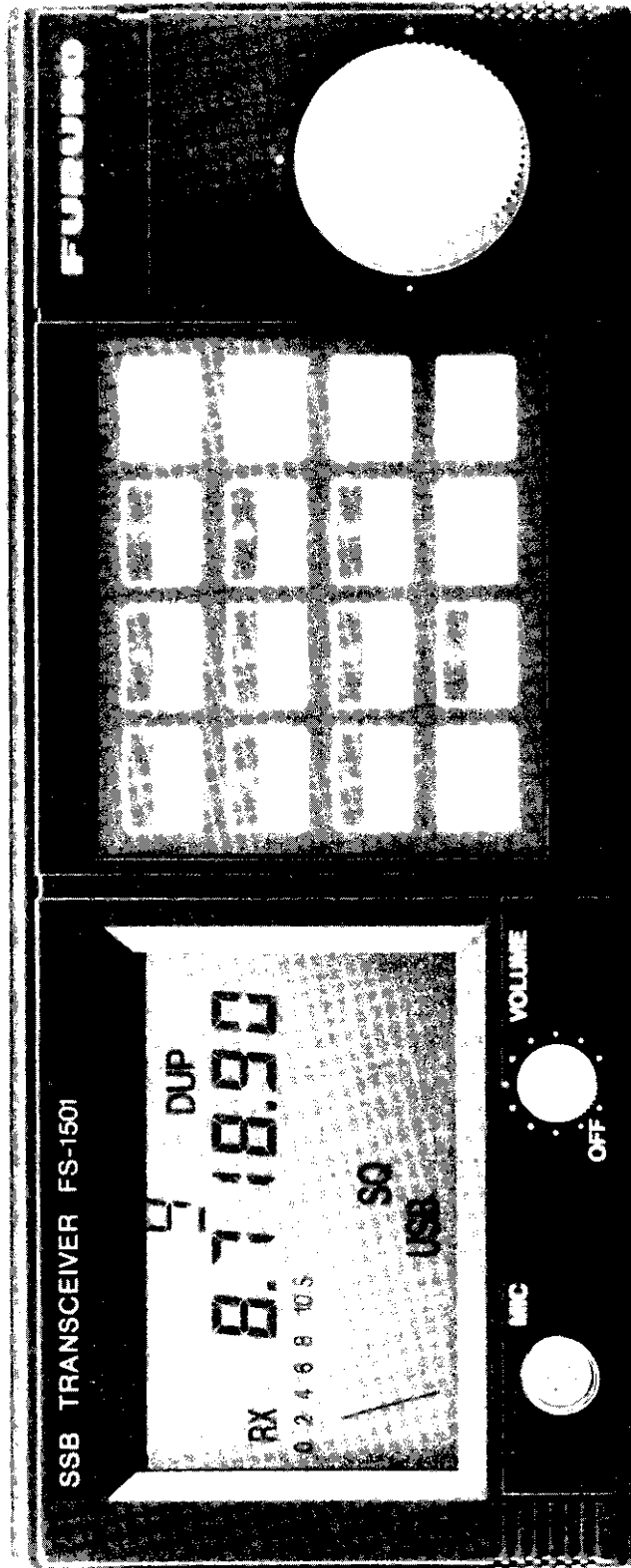

CHAPTER 1 OPERATION

1.1 DESCRIPTION OF FRONT PANEL CONTROLS

All the operations of this radiotelephone can be done from the front panel. The RF GAIN control, AGC ON/OFF switch and SQUELCH threshold control are eliminated from the front panel to ease the operation.

The touchpad keys with numerals on them are also used to enter channel number, frequency or scan group number. To enter numeric data, press [#] key before pressing the numeric key, and then press [ENT] key after all the numbers are entered.

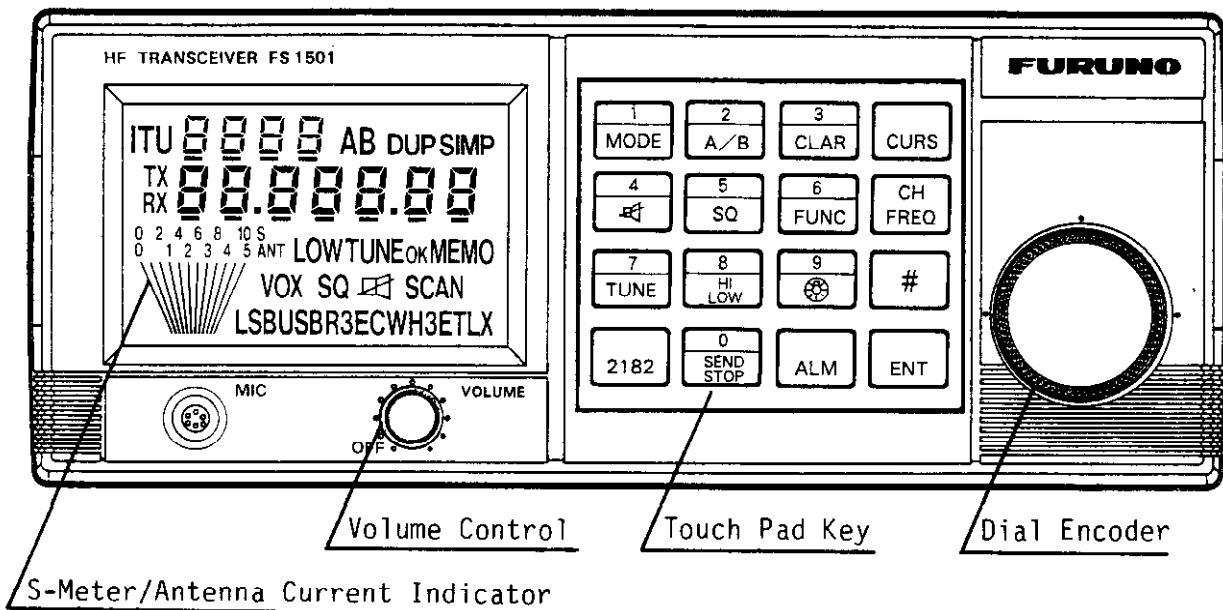
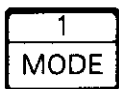

Fig. 1-1 FS-1501 Front Panel



Adjusts audio level from speaker (handset). Also turns the transceiver on or off.



Selects an class of emission. Each time the key is pressed the class of emission changes as shown below.

LSB — USB — R3E — CW — H3E — TLX

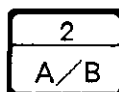

Selects memory-A or -B frequency on simplex channel.

On semi-duplex channel, pressing the key enables watch on your transmission frequency (receiving frequency is stored in memory-A and transmission frequency is in memory-B.)

* This function is effective only on the "User Channel Mode" and "ITU Channel Mode."
Selects simplex or duplex on MEMORY Mode.

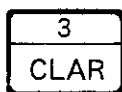

Together with this speech clarifier touch pad and the dial, the receiver is capable of reducing the frequency error to 5Hz. The frequency range is $\pm 150\text{Hz}$ in 10Hz steps.

* This function is ineffective on "Frequency Mode."

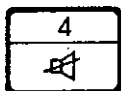

Turns internal and/or external speaker on or off.

 appears on the screen when the speaker is off.

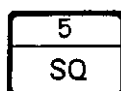

Turns the squelch function on or off.

SQ appears on the screen when the squelch is on.

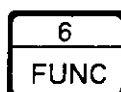

Turns the scanning function on or off.

SCAN is indicated when scanning reception is selected.

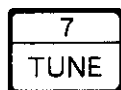

Tunes up the automatic antenna coupler.

TUNE is displayed during tuning process.
TUNEOK is displayed when tuning is completed and 2 sec. later it disappears.

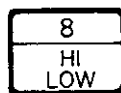

Changes output power high or low.

LOW is indicated on-screen when output power is reduced and disappears while operating in full power.



Controls illumination of LCD (Liquid Crystal Display) and the backlight for the touchpad key panel in four steps.

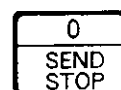

When pressed simultaneously with the [ALM] key, this key activates transmission of two-tone signal.



Permits the test of the two-tone alarm signal required by SOLAS. If [SEND/STOP] key is pressed simultaneously (within 1 sec), the alarm signal is transmitted in air.

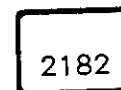

Emergency key to select "2182kHz J3E" by single action.



Moves cursor to change "ITU Channel number" or "Frequency"



Selects desired frequency selection mode among "Frequency," "User Channel" and "ITU Channel (international marine channel)" modes.

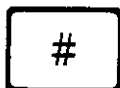

Activates function of numeral keys for "Memory", "Recall" and "Change" of channel and frequency.



Terminates data entry. Also may be pressed to clear incorrectly entered data.

OTHERS

BUZZER

The transceiver contains a buzzer which sounds in the following cases.

- 1) When a key input sequence is completed successfully, a short beep is generated.
- 2) When the operator attempts to enter incorrect (illegal) data, three beeps will be generated. The input data is rejected and the previous data will be restored.
- 3) When the Antenna Coupler fails in antenna tuning, five beeps are generated without displaying the "TUNE ok" sign.

1.2 TURNING ON/OFF THE POWER

Turning the [VOLUME] control clockwise supplies power to the transceiver and the set is ready to receive a signal on the last used frequency.

When the supply voltage is higher than 17VDC the protector trips and the transceiver will be turned off automatically. If this happens, first switch off the set and check whether the battery charger is operating or not, then check transceiver input voltage. If the voltage is 12 to 15V, the unit may be turned on again.

To turn off the power, turn the [VOLUME] fully counterclockwise till you feel a "click". All front panel settings and TX/RX frequencies at power off will be preserved in the back-up memory.

1.3 ADJUSTING THE DIMMER



Backlight for the LCD and the touchpad key panel may be adjusted by the [] touchpad.

Each pressing of [] will change it in four steps successively.

→ bright → dim → dark → lights off]

1.4 TURNING ON/OFF THE LOUDSPEAKER

In case that you are using a handset and no need of the internal or external speaker then you can turn the loudspeaker off.

Press [] to turn the speaker off, and  is displayed on the LCD.

1.5 SELECTION OF FREQUENCY

There are three ways to select a frequency.

Press [CH/FREQ] to select a desired mode.

Table 1-1 Types of Frequency Set

Mode	Procedure	Ref. to
Frequency Mode	Direct frequency input by the numeric touchpad.	Fig. 1-2
User Channel Mode	Recalling a pre-programmed frequency by specifying the channel number.	Fig. 1-3
ITU Channel Mode	Recalling ITU channel (Factory programmed 192 international marine SSB channels) by specifying the channel number.	Fig. 1-4

Frequency Mode

In this mode, any frequency between 1.6MHz and 23MHz can be set in 10Hz (0.01kHz) steps and can be received/transmitted freely.

Note 1) 100kHz to 1.6MHz and 23 to 30MHz are also available for reception, but the sensitivity is low.

- 2) It is not unlawful to divulge what is overhead by radio or wire. Furthermore each of the marine frequencies is authorized for a specific type of communication. For these reasons, it is recommended to use this mode only for programming of "User Channel Mode".

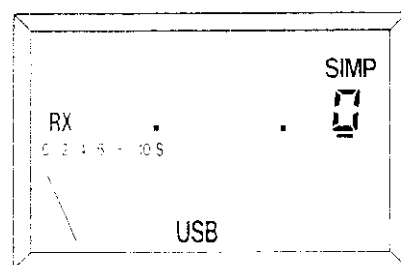

Fig. 1-2 Initial Display of Frequency Mode

Frequency Entry

Press [#] [1] [2] [3] [4] [5] [6] [ENT] for 12,345.60 kHz.

- Note 1) The numeral entered just before pressing the [ENT] key becomes the number in the 100Hz (= 0.1 kHz) place.
- 2) If the set frequency is entered out of the range between 100kHz and 30MHz, three beeps are emitted, informing you unacceptable data entry. Then the set frequency is rejected and the previous frequency is restored.
- 3) This mode can not be used on semi-duplex communication.

Tuning by Dial Encoder

The lower three digits of the frequency number (x0.01kHz, x0.1kHz and x1kHz) may be changed by turning the dial encoder. To increase the frequency number, rotate the dial encoder clockwise and to decrease it, turn the dial counterclockwise.

To change the frequency faster, press [CURS] key to locate the "cursor" at "x1kHz" or "x0.1kHz" digit. (The frequency can be changed in the step where the cursor is located.)

If changing the frequency by this method is inconvenient, enter a new frequency with the touchpad key.

User Channel Mode

Channel number and frequency are displayed with cursor located at channel number.

To use this mode, you should write in a frequency into the memory and assign a number(1 to 64). The number will be the channel number and you can recall the frequency with this number. Refer to section 1-13 CHANNEL PROGRAMMING to write in a frequency in each channel.

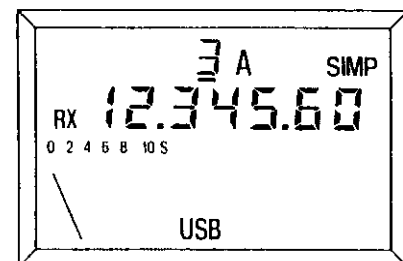

Fig. 1-3 Initial Display for User Channel Mode

Recall by Dial Encoder

Turn the dial encoder to recall the channel number. If the "cursor" is not located at the channel number side, press [CURS] key.

Recall by key

Press [#] [3] [ENT] for channel 3.

Note 1) If a channel having no frequency assigned to it is specified, the set will reject the input and restore the previous channel.

[Simplex and Semi-duplex]

Each time you press [A/B] key, the display changes to (a) or (b) alternately.

Table 1-2 Frequency Change by [A/B]

Selected Channel	No.	Selected Frequency	LCD Display
Simplex Channel	(a)	Memory-A	A SIMP
	(b)	Memory-B	B SIMP
Semi-duplex Channel	(a)	Memory-A for Reception Memory-B for Transmission	DUP
	(b)	Memory-B for Reception *	B SIMP

* Enables watch on your transmission frequency

ITU Channel Mode

ITU channel number and frequency are displayed. Right two numbers show the "channel number" and the rest shows the "band".

Selection by key

Press [#] [4] [0] [1] [ENT] for international channel 401.
Each time you press [A/B] key, then the display changes to (a) or (b) alternately.

Band Number Channel Number Cursor

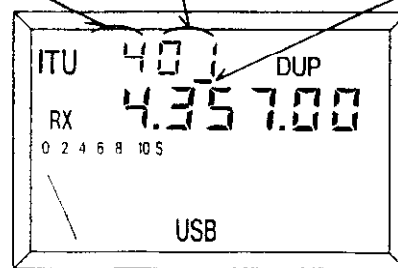

Fig. 1-4 Initial Display for ITU Channel Mode

Table 1-3 Frequency Change by [A/B] Key

Selected Channel	No.	Selected Frequency	LCD Display
Semi-duplex Channel	(a)	Memory-A for Reception Memory-B for Transmission	DUP
	(b)	Memory-B for Reception *	B SIMP

* Enables watch on your transmission frequency

Recall by Dial Encoder

- 1) The cursor is located at the channel side.
To change the "band", press [CURS] to move the cursor to band number side. Select a desired band number by turning the dial encoder.
- 2) Press [CURS] key to move cursor to the channel number side.
Select a desired channel number by turning the dial encoder.

1.6 SELECTING THE CLASS OF EMISSION

Press [MODE] key until the desired mode appears on the LCD.
Each pressing changes the emission mode successively.

— LSB - USB - R3E - CW - H3E - TLX —



Table 1-4 Emission Mode

Emission Mode	Meaning	Main use	Power
LSB	SSB, Lower Side Band	Land Mobile	150W
USB	SSB, Upper Side Band	Marine Mobile, General	150W
R3E	SSB(USB) with pilot carrier	Special Purpose	150W
CW	Morse Code Wave	Telegraph	75W
H3E	SSB with full carrier	Communication on 2182kHz	37.5W
TLX	Frequency Shift Keying	Radioteletype (RTTY)	75W

Note 1) Select "USB" for voice communication on marine mobile operation.

- 2) When emergency transmission is made by depressing [2182] key, emission mode J3E is automatically selected. If communication on H3E (AM compatible) is required, press [MODE] key until "H3E" is displayed on the LCD.

1.7 ADJUSTING THE VOLUME

Adjust the [VOLUME] control for the sound level desired. If  is present on the display, hit [] key to activate the speaker.

1.8 COMMENCING COMMUNICATION

Watch on the Desired Frequency

Commence transmission after confirming that the desired channel (frequency) is not busy.

In semi-duplex channel operation, verify that both the coast station and the other ship station are not "in" by switching from channel A, then to B. If neither one is "in", return to channel A ("DUP" is displayed on the LCD) and begin your transmission.

Antenna Tuning

Press [TUNE] for tuning by the Automatic Antenna Coupler.
During the tuning (2 to 15 sec.), "TUNE" is displayed on the LCD, and when tuning is completed "TUNE ok" is displayed. Tuning is also initiated by the first press of press-to-talk switch or the first keying of the telegraph key after the frequency is changed.

- Note 1) The Antenna Coupler has a self-memorizing capability, that is, the optimum tuning point is memorized by the back-up memory for about one week. The tuning time within the same frequency band is fast, 0.2 to 1.5 sec. However, it is a good habit to wait for a short period after pressing the press-to-talk switch at the beginning of communication.
- 2) If an antenna untunable by the antenna coupler is used, i.e. length is not within the tuneable range of the coupler, it might take long to complete the tuning. When good tuning is not available, the unit beeps and "TUNE ok" won't be displayed on LCD. In this case, the coupler is not matching with the antenna. Though it can transmit with reduced performance, there is a possibility of damaging the equipment if it is transmitted for a long period of time. Ensure the proper length antenna is used.

Communication Using MICROPHONE

- 1) Confirm that "TUNE ok" is displayed.
- 2) Press the press-to-talk switch on the microphone.
- 3) Keep a distance of about 5cm between the microphone and your mouth.
- 4) Speak into the microphone in a normal voice. There is no need to shout.
- 5) Release the press-to-talk switch for reception.

Communication Using TELEGRAPH key

- 1) Confirm that the CW mode is selected.
- 2) Begin your transmitting by manipulating the telegraph key.

Making TELEX COMMUNICATION (Optional TELEX/REMOTE KIT is needed)

- 1) Confirm that proper frequency and the "TLX" mode is selected.
The frequency displayed on the LCD is the "carrier frequency".
- 2) Operate the telex terminal.

Note: If you need fine tuning to receive clear telex signal, clarify the signal by referring to section 1-9.

Using VOX (Optional VOX KIT is needed)

- 1) Press [ENT] and [SEND/STOP] together.
"VOX" is displayed on the LCD and the VOX operation is enabled.
- 2) Press [ENT] and [SENT/STOP] together to escape from VOX operation.

Monitoring Transmission

During transmission, the pointer of the needlegraph indicates antenna current. The deflection of the pointer changes with respect to the frequency, antenna length and grounding condition.

LSB,
USB,
R3E

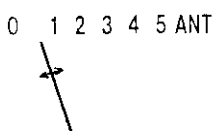

After the press-to-talk switch is pressed, the pointer deflects rightward according to the loudness of your voice.

CW

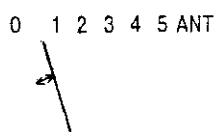

The pointer moves according to key operation

H3E



It deflects slightly when the PTT is pressed, and defects rightward according to voice level.

TLX

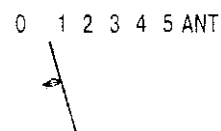

When sending a message, the pointer positions stably. It returns to the left between intervals in the message.

Monitoring Receiving Signal Strength

During reception, the needlegraph indicates the relative signal strength of the incoming signal. The pointer deflects rightward as the signal get stronger.

1.9 CLARIFYING THE RECEIVED SIGNAL

During "User Channel Mode" and "ITU Channel Mode" clarifying of the voice may be necessary. In such a case press [CLAR] key. Before pressing the key, the cursor is located at the channel number, but after pressing it will move to the frequency number side. Then you can change the frequency (0.01kHz order only) by the dial encoder. To move the cursor back to the channel number, press [CLAR] key again. In "Frequency Mode," adjust the frequency by the dial encoder.

1.10 TRANSMISSION OF TWO-TONE ALARM

In case of distress or an emergency, call for a help on 2182kHz. Before transmitting the call, transmit the two-tone alarm. This will call a 2182kHz Watch Receiver's attention, since this frequency is watched 24 hours a day.

Note 1) Transmit 2182kHz only in an emergency.

2) Refer to "DISTRESS CALLING PROCEDURE" on the last page of this manual for the procedure to make a distress call

Transmission

1) Press [2182] to set the frequency to 2182kHz.

Testing

1) Alarm-tone can be monitored by pressing [ALM] key alone.
2) To cease testing press [SEND/STOP] key.

1.11 REDUCTION OF TRANSMISSION POWER

When using the transceiver in a harbor or near the shore you can normally transmit in low power, since you are close enough to a receiving station etc. to make a call. The transmission power may be lowered as follows.

1) Press [HI/LOW] to reduce the power.
"LOW" is displayed on the LCD. The output of the SSB signal (150W) is reduced to 60W or less.
2) To return to high power output, press [HI/LOW] key again.

1.12 TURNING ON/OFF THE SQUELCH

When the noise is too jarring during stand-by condition, then press [SQ] to activate the squelch function. "SQ" is displayed on the LCD.

It mutes the audio output in the absence of incoming signal, but note that when the level of the receiving signal is too low then it may extinguish both noise and the signal.

1.13 CHANNEL PROGRAMMING

This radio contains groups of memories to memorize frequencies and emission mode. The contents of the memory may be read out by specifying the memory number, i.e., channel number.

Writing a Frequency into Memory

1) Hold down [#] key and turn on the power.
2) Confirm that "MEMO" is displayed on LCD, then release the [#] key.
If not, turn off the transceiver and try again.
3) Select desired channel number and memory (ex. 1A, 1B) by the dial encoder.
4) Press [#] and enter frequency number then press [ENT] key.
5) Press [MODE] to choose emission mode.
6) Press [A/B] key to select either Simplex or Duplex.
7) Repeat procedures through steps 3 to 6 for further channel memory.

*Obsolete frequencies may be written over.

*To erase a frequency, recall the frequency that you don't need then enter "0" by pressing [#] [0] [ENT].

*If you do not desire to erase the frequency after entering "0", then press [A/B] key immediately. Then the memory won't be erased.

Escaping from the Memory-write Mode

1) Turn off the transceiver.

EXAMPLES

[EXAMPLE 1] Assign 12,345.60kHz, USB, simplex, to channel 40, memory-A.

- 1) Hold down [#] key, turn on the power. Release [#] key when "MEMO" is displayed on the LCD.
- 2) Select "channel 40 A" by dial encoder.
- 3) Press [#][1][2][3][4][5][6][0][ENT] for 12,345.60kHz.
- 4) Press [MODE] key until "USB" is displayed.
- 5) Confirm "A SIMP" is displayed. If not press [A/B] key.

[EXAMPLE 2] Assume that you are making User Channel Programming with the following stations.

Table 1-5 Coastal Station and the Call Sign

Name of Station	Call Sign	Mode
Seattle Marine Radio	KLB	Simplex
Bermuda Radio	VRT	Simplex
Dixon California	KMI	Duplex
Habama Radio	CLA	Duplex
Ocean Gate, New Jersey Radio	WOO	Duplex
Pennsuko, Florida Radio	WOM	Duplex
Portishead Radio	GKA	Simplex

When writing in a frequency, "group number" should always be kept in mind since scanning reception is done by "Group Number".
In this example the group is made according to the coast station.

Simplex Channel

To assign the simplex channel as KLB, VRT and GKA, for example, operation is the same as example 1.

Duplex Channel

For example, assign KMI, Dixon, California Radio (USB 4357.4kHz & 4063kHz Duplex) to Channel 9.

- 1) Hold down [#] key and turn on the power. Release hold of [#] key when "MEMO" is displayed.
- 2) Select "channel 9 A" by dial encoder.

- 3) Press [#][4][3][5][7][4][0][ENT] for 4357.4kHz.
- 4) Press [MODE] key until "USB" is displayed.
- 5) Confirm "DUP" is displayed. If not press [A/B] key.
- 6) Turn the dial encoder one click and choose "channel 9 B".
- 7) On the display "USB" and "DUP" should be displayed. If not then go back to "channel 9 A" and retry items (4) and (5).
- 8) Press [#][4][0][6][3][0][0][ENT] for 4063kHz.

Table 1-6a USER CHANNEL LIST (MEMORY CHANNEL LIST) Frequency in kHz

GROUP No. (for SCAN)	CH No.	MEMORY A T/R for SIMP RX for DUP	MEMORY B T/R for SIMP TX for DUP	S	PURPOSE / REMARKS
1	1	6411.	4277.0	*	A: KLB, B: VRT,
	2	8582.	6487.5	*	Seattle Bermuda
	3	12907.5	8449.	*	
	4	17007.2	12709.2	*	
	5	.	16947.5	*	
	6	.	.		
	7	.	.		
	8	.	.		
	9	4357.4	4063.		KMI, Dixon, California
2	10	8728.2	8204.3		
	11	8784.	8260.1		
	12	13100.8	12330.		
	13	13187.6	12416.8		
	14	17236.	16463.1		
	15	.	.		
	16	.	.		
	17	4403.9	4109.5		KMI, Dixon, California
3	18	8743.7	8219.8		
	19	13103.9	12333.1		
	20	13107.	12336.2		
	21	17239.1	16466.2		
	22	22636.3	22040.3		
	23	.	.		
	24	.	.		
	25	4357.4	4063.		CLA, Habana
4	26	4410.1	4115.7		
	27	8743.7	8219.8		
	28	8759.2	8235.3		
	29	13150.4	12379.6		
	30	13184.5	12413.7		
	31	17310.4	16537.5		
	32	17316.6	16543.7		
	33	4422.5	4128.1		W00, Ocean Gate, New Jersey
5	34	4403.9	4109.5		
	35	4388.4	4094.		
	36	4385.3	4090.9		
	37	8796.4	8272.5		
	38	8762.3	8238.4		
	39	8749.9	8226.		
	40	8740.6	8316.7		

Table 1-6a USER CHANNEL LIST (MEMORY CHANNEL LIST) Frequency in kHz

GROUP No. (for SCAN)	CH No.	MEMORY A T/R for SIMP RX for DUP	MEMORY B T/R for SIMP TX for DUP	S	PURPOSE / REMARKS
6	41	13184.5	12413.7		W00, Ocean Gate, New Jersey
	42	13131.8	12361.		
	43	17325.9	16553.		
	44	17310.4	16537.5		
	45	17245.3	16472.4		
	46	17291.8	16518.9		
	47	22596.	22000.		
	48	22608.4	22012.4		
7	49	4363.6	4069.2		W0M, Pennsuco, Florida
	50	8722.	8198.1		
	51	13116.3	12345.5		
	52	17232.9	16460.		
	53	22639.4	22043.4		
	54	.	.		
	55	.	.		
	56	.	.		
8	57	.	4286.	*	A: B: GKA,
	58	.	6368.9	*	Portishead
	59	.	8545.9	*	
	60	.	12822.	*	
	61	.	17098.4	*	
	62	.	22467.	*	
	63	.	.		
	64	.	.		

S : This column is for denoting when the channel is used for Simplex.

Using the example table above, if you wish to hear KLB, Seattle Marine Radio then you can scan Scan Group "1" memory "A". Frequencies 6411, 8582, 12907.5, 17007.2 (kHz) are received every 2 seconds. The VRT, Bermuda Radio will be Scan Group "1" memory "B", frequencies 4277.0, 6487.5, 8449.0, 12709.2 and 16947.5 (kHz) are received if "B" is selected by depressing [A/B] key before starting scanning.

1.14 SCANNING RECEPTION

This function receives one by one the frequencies (maximum 8 frequencies at a time) which are memorized in the memory for 2 seconds each. Even if a signal is detected, the receiver does not lock on that channel. To stop scanning, press [ENT] key or the press-to-talk switch on the microphone.

Note 1) This operation is activated only in the User Channel Mode.

2) The scanning is made in the group that the channel number just before pressing [FUNC] key belongs to.

Setting the Dwell Time

- 1) Press [CH/FREQ] key to select "User Channel Mode".
- 2) Press [#] [9] [0] [ENT] to recall Ch.90.
- 3) Turn the dial to set the desired dwell time among 1 to 9 sec.
Default value is 5 sec of dwell time.
- 4) Press [SEND/STOP] to escape from this function.

Setting the Threshold Level

- 1) Press [CH/FREQ] key to select "User Channel Mode".
- 2) Press [#] [9] [1] [ENT] to recall Ch.91.
- 3) Turn the dial to set the desired level of Sensitivity meter among level 1 to 9. Default value is 3.
- 7) Press [SEND/STOP] to escape from this function.

Starting Scanning Reception

- 1) Turn the dial to select the channel number which corresponds to the scan group that you desire.

Scan group number and corresponding channel number are as follows.

Table 1-7

Scan Group Number	Channel Number and Scanning Range
1	1 to 8
2	9 to 16
3	17 to 24
4	25 to 32
5	33 to 40
6	41 to 48
7	49 to 56
8	57 to 64

- 2) Then select memory-A frequencies or memory-B frequencies by pressing [A/B] key.
- 3) Press [FUNC] key to commence scanning.
- 4) To stop scanning, press [ENT] key or press-to-talk switch on the microphone.

1.15 IN THE EVENT OF COUPLER FAILURE

The AT-1500 Antenna Coupler starts automatic antenna tuning the moment the PTT switch on the microphone is pressed or the [TUNE] key on the transceiver is pressed. After pressing the switch, tuning will be completed in 2 to 15 sec. for a newly used frequency or in 0.5 sec. for a previously used frequency. A built-in memory stores capacitor and coil settings. This is why it can tune a previously used frequency so quickly.

When the control circuit in the Antenna Coupler does not function properly, you can not transmit effectively. In this case, should an emergency arise, you can

transmit 2182kHz by switching the Coupler to "manual operation". But for this operation, "preset" should be done beforehand (see page 5-17 "MANUAL 2182kHz SETTING" for this preset.) The following shows the way to switch over to "manual operation."

- 1) Open the cover of the Antenna Coupler.
- 2) Set the toggle switch S3 to "MANUAL 2182kHz" position.
- 3) Close the cover.
- 4) Turn on the power and select 2182kHz from the transceiver unit.
(Coupler can be tuned to 2182kHz only.)
- 5) Call the coastal station.

Note : See "CHAPTER 4 PARTS LOCATION" for locations of each parts.

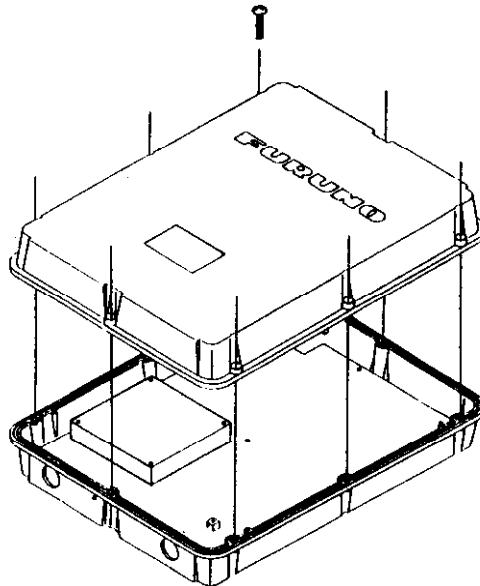

CAUTION

When closing the cover, fit the gasket properly and tighten each bolt to the same amount of torque. If the bolt is not tightened properly, water may leak inside the coupler.

CHAPTER 2 MAINTENANCE

2.1 GENERAL

This radio is designed and constructed to provide years of trouble-free operations. However, no radio equipment can perform its intended functions without periodic checks and inspections. The following table shows the items to be checked from time to time. (It is ideal to have a licensed radio technician check the transceiver annually.)

Table 2-1 Recommended Periodic Checks

Check Item	Check Points/Methods	Remedy/Remarks
Antenna	<ol style="list-style-type: none"> 1. Check that there is no physical damage, corrosion nor water leakage. (Whip antenna) 2. Check that the antenna is spanned properly, keeping sufficient distance from other metallic structure on boat. (Wire antenna) 	<ol style="list-style-type: none"> 1. If damaged, replace it. 2. If necessary, re-span the antenna wire.
Insulators	<ol style="list-style-type: none"> 1. Check that there are no cracks nor salt water accumulation on the insulators. 2. Check that the connection at lead-in insulator is tight and rust-free. 	<ol style="list-style-type: none"> 1. If crack is found, replace the damaged one. Use fresh water to remove salt water accumulation. 2. Remove rust on wire and terminal, and tighten bolt and lock nut. Cover metallic part with sealing compound.
Antenna Coupler	<ol style="list-style-type: none"> 1. Check the contact conditions at the following points. <ul style="list-style-type: none"> * Antenna terminal connection * Grounding wire connection * Coaxial cable connections * Composite cable connection (Terminal board) 2. Check that the coupler lid and cable glands are secured firmly. 3. Check that there is no physical damage, corrosion or salt water deposit on the Antenna Coupler. 	<ol style="list-style-type: none"> 1. If loosened, fasten firmly. If corroded, clean the contacts. 2. Fasten coupler lid firmly and evenly to avoid water leakage. 3. If damaged, replace it.

-Continued-

Check Item	Check Points/Methods	Remedy/Remarks
Transceiver	<ol style="list-style-type: none"> 1. Check the contact conditions at the following points. <ul style="list-style-type: none"> * Antenna coaxial plug connection. * Grounding wire connection. * Composite cable connection. * Power cable connection. 2. Check that there are no obstacle on top of the cabinet. 	<ol style="list-style-type: none"> 1. If loosened, fasten firmly. If corroded, clean. 2. Remove any objects from the top of the unit.
Power supply Power Cable Battery	<ol style="list-style-type: none"> 1. Check that the supply voltage is within the rated range. 2. Check that there is no loose or corroded connection at power terminals. 3. Check that the battery is fully charged. 	<ol style="list-style-type: none"> 1. If the voltage is out of rated range, consult an electrician or call for service. Low voltage may cause erratic operation of the equipment. 2. If the battery is discharged, recharge the battery.
Feeder (coax. cable), control cable	<ol style="list-style-type: none"> 1. Check that there is no damage to the cables, which may cause water to leak into them. 	<ol style="list-style-type: none"> 1. If damaged, replace it.
P.C. Board connection	<ol style="list-style-type: none"> 1. Check that jumper cables between boards are connected firmly. 	<ol style="list-style-type: none"> 1. Reinstate loose connector.
Air Vents	<ol style="list-style-type: none"> 1. Ensure that air vents are not obstructed. 	<ol style="list-style-type: none"> 1. Remove any objects inhibiting air circulation.
Microphone	<ol style="list-style-type: none"> 1. Check that microphone connector is fastened tightly. 	<ol style="list-style-type: none"> 1. Move plug connector in and out to check for good contact.

2.2 FUSE REPLACEMENT

To protect the transceiver from serious damage, two 30A fuses are provided in the snap-in fuse holders on the power cable. The fuse protects against over voltage/reverse polarity of the ship's mains or internal fault of the equipment. If the fuse has blown, first find out the cause of the problem before replacing it.

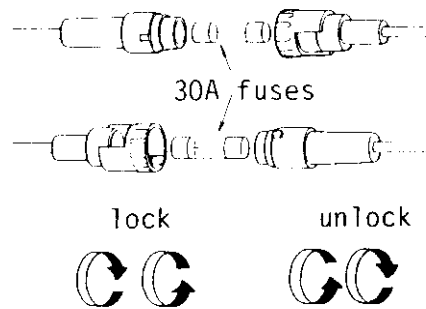

Fig. 2-1 Fuse Replacement

Do not use a fuse rated more than 30A, since it may cause more serious damage to the equipment.

2.3 CLEANING

The units must be kept clean and dry all the time. Wipe off dirt, dust and moisture with a soft dry cloth. For persistent dirt, use diluted detergent on a soft cloth. **DO NOT USE PLASTIC SOLVENT FOR CLEANING.** If the transceiver unit is not used for a long period, cover it with a dust cover.

CHAPTER 3. MINOR TROUBLESHOOTING

3.1 TROUBLE FINDING LIST

Various protection facilities are incorporated in this unit to minimize malfunctioning. However, if any unusual symptom is encountered during operation of the equipment, first check the connections of connectors and terminal boards. Find the symptom on the following list and perform the specified remedy. In some cases, the problem will be alleviated by rechecking operating method, for example, data entry sequence, etc. Do not attempt further check inside the unit. This is best left to a qualified technician. Careless handling or adjustment may cause serious damage to the equipment.

Table 3-1 Trouble Finding List

Symptom	Possible Cause	Remedy
Unit does not work at all. (No frequency display nor light.)	<ol style="list-style-type: none"> 1. Switch at mains switch board is turned off. 2. Battery is flat or poor contact at terminals. 3. Rectifier (if installed) is faulty. 	<ol style="list-style-type: none"> 1. Turn on the mains switch. 2. Recharge battery and tighten terminal connections. 3. Check fuse on the rectifier.
Frequency displayed but no lamp lights.	<ol style="list-style-type: none"> 1. DIMMER switch is in OFF state. 	<ol style="list-style-type: none"> 1. Press [] key.
Power is on but no sound.	<ol style="list-style-type: none"> 1. SP OFF switch is activated. 2. VOLUME control is set too low. 3. SQ is on. 	<ol style="list-style-type: none"> 1. Press the SP OFF switch. 2. Turn VOLUME control clockwise. 3. Press [SQ] if "SQ" is displayed.
Can't clarify SSB signal.	<ol style="list-style-type: none"> 1. Wrong emission mode is used. (ex. receiving USB signal in H3E mode.) 2. Frequency is detuned. 	<ol style="list-style-type: none"> 1. Select the same emission mode as incoming signal. 2. If it is User/ITU Channel Receive mode, adjust frequency by dial after pressing [CLAR] key. In Free Frequency Receiving Mode, adjust by dial.

-Continued-

Symptom	Possible Cause	Remedy
Can't store frequency into channel memory.	1. Attempting to store into wrong channel number.	1. Store it into the proper channel number.
Can't send or receive telex	1. Wrong emission mode is used. 2. Frequency setting is inaccurate.	1. Select TLX mode. 2. Fine tune the frequency.
Telex won't Synchronize.	1. Sent message while the coupler is being tuned.	1. Press [TUNE] key and wait for the completion of coupler tuning before sending message.
Ant. Coupler won't tune to antenna.	1. Antenna is disconnected or shorted to ground. 2. Antenna is out of tunable length. 3. Coupler ground is insufficient. 4. Toggle switch (S1) in the coupler is set to "MANUAL 2182kHz" position. 5. Breaker has tripped. 6. Cable is loose or disconnected.	1. Check the antenna connections. 2. Antenna should be 7 to 15 meter long. 3. Check the coupler ground connections. 4. Set the switch to "AUTO" position. 5. Check main voltage and polarity, then replace breaker to the normal position. 6. Secure cable connection.
Two-tone alarm generator does not work.	1. Only [SEND/STOP] key is pressed.	1. Press [ALM] key and [SEND/STOP] key simultaneously.

3.2 SELF-TEST

CHECK OF RELAY

The function of the relays which select capacitor and coil are checked with the procedure below.

- 1) Open the shield cover inside the coupler. There you see a DIP switch S2.
- 2) Set No.2 of S2 to "ON" position.
- 3) Press "TUNE" switch S1 right below.
- 4) Then the 20 LEDs (CR33 to CR52) will light one by one for 1 sec. each if the relay is energized, and then they blink all at once when the test is over.

LED and corresponding relay are as follows.

CR 33 - K 3	CR 38 - K 8	CR 43 - K 14	CR 48 - K 19
CR 34 - K 4	CR 39 - K 9	CR 44 - K 15	CR 49 - K 20
CR 35 - K 5	CR 40 - K 10	CR 45 - K 16	CR 50 - K 21
CR 36 - K 6	CR 41 - K 11	CR 46 - K 17	CR 51 - K 13
CR 37 - K 7	CR 42 - K 12	CR 47 - K 18	CR 52 - K 22

Note : See "CHAPTER 4 PARTS LOCATION" for locations of each parts.

- 5) Now the Tuner is set to the status before Self-test.
- 6) Never fail to re-set No.2 of DIP switch S2 to "OFF" position or you will be unable to transmit.
- 7) Ensure that all switches of DIP switch S2 are set to "OFF" position before you close the cover.

CHAPTER 4 PARTS LOCATION

4.1 TRANSCEIVER UNIT

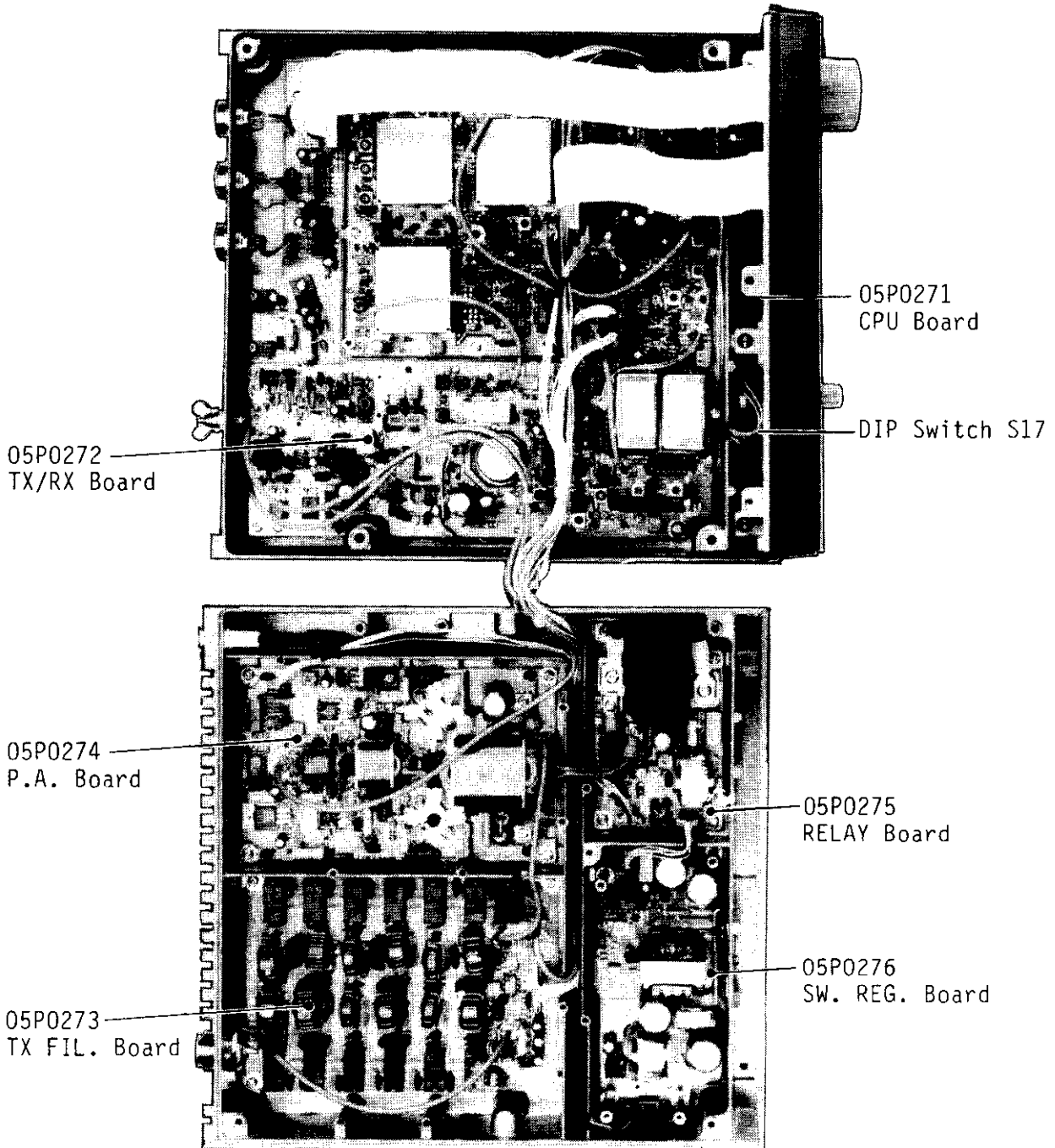

Fig. 4-1 Inside View of Transceiver Unit

4.2 ANTENNA COUPLER UNIT

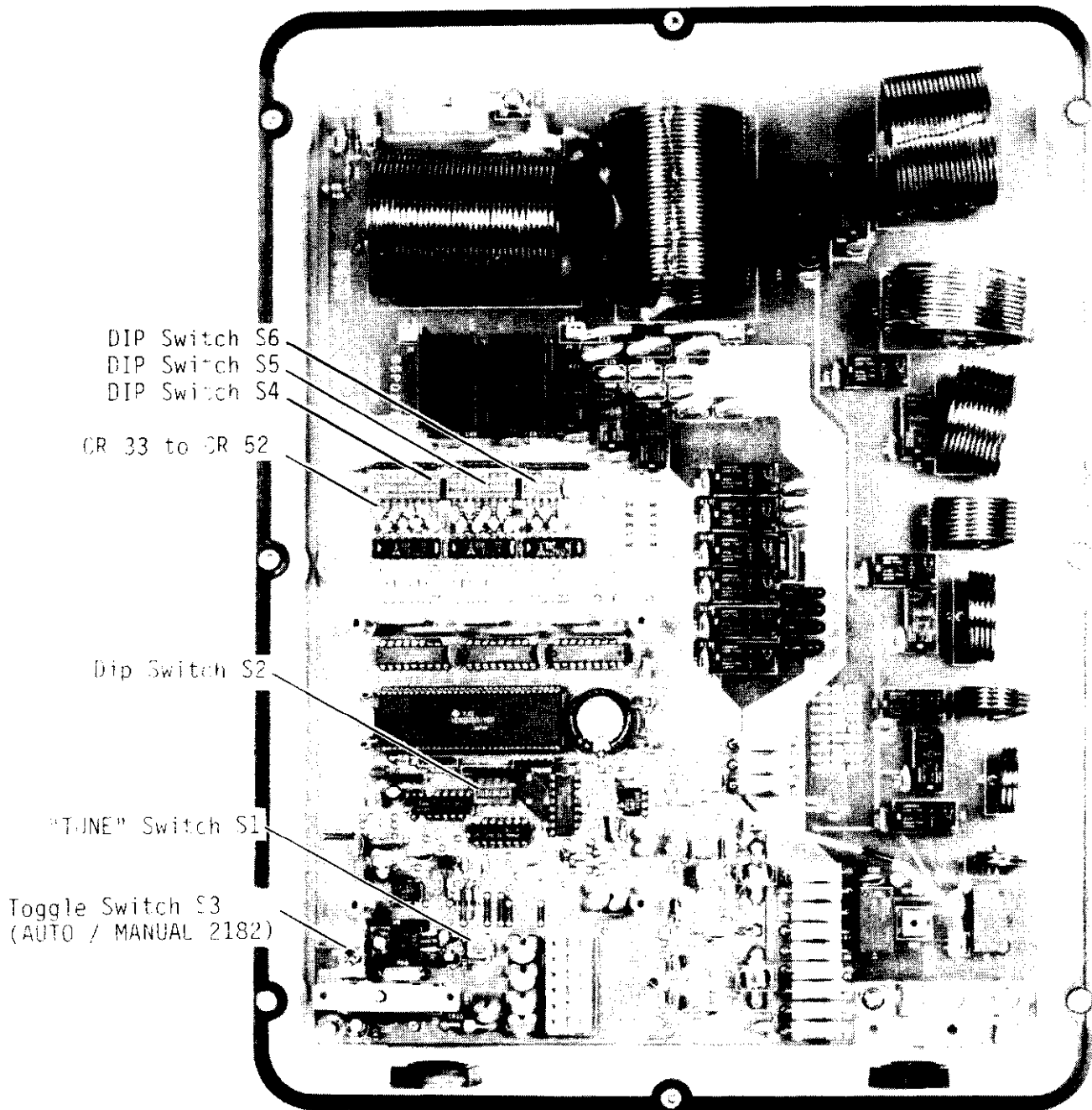

Fig. 4-2 Inside View of Antenna Coupler

CHAPTER 5 INSTALLATION

5.1 GENERAL NOTES ON INSTALLATION

No machine can perform to the utmost of its ability unless it is installed properly. Before beginning installation, note the following precautions.

AVOID WATER SPRAY

If the radiotelephone is to be installed on a boat, the transceiver unit should be located on the bridge, in the cabin or the other suitable place where they are readily accessible and reasonably protected from water spray. Though the transceiver unit is splash-proof, it is not designed to be used outside the cabin, directly exposed to the environment. The Antenna Coupler can be installed outside the cabin, however, select a place where it will not be exposed to salt water spray. Salt water on the antenna insulator may cause unstable operation of the Coupler and may result in transmission loss.

CAUTION : Furuno will assume no responsibility for the damage caused by exposure to salt water spray.

AVOID SHOCK OR VIBRATION

This equipment is designed to withstand possible shocks and vibrations normally experienced onboard the vessel or on the vehicle. However, excessive and continued shock and vibration can shorten the life of equipment. Where necessary, appropriate shock absorption measures should be taken.

AVOID HOT ENVIRONMENT

It is recommended to keep the transceiver unit out of direct sunlight or at least shaded because of the heat that can build up inside the unit. It is also important to provide ventilation space behind and above the transceiver unit for sufficient air circulation.

AVOID ONBOARD NOISE

Though this radio is well shielded from onboard noise by its aluminium die-cast cabinet, it is recommended to install the transceiver unit away from pulse generating equipment, computer-controlled equipment or motor operated equipment, such as radar, echo sounder, gyrocompass, loran, sat-nav, other navigation equipment, etc.

REQUIREMENT FOR POWER SUPPLY AND CABLE

Use the proper size of power conductor. This equipment requires ample current (Peak 30A at the envelope of voice) to deliver full power the antenna. Use a battery having a capacity of 130AH or more. A small amount of corrosion at the connection to the power cable can markedly reduce transmission power. Use heavy gauge wire (see table below) and keep the length as short as possible.

Table 5.1 Required Extension Power Cable

Cable length to 12VDC power supply	Conductor area (mm ²)	AWG #	British S.W. Gauge
10m	8mm ²	#8	#10
15m	12mm ²	#6	#8
20m	16mm ²	#5	#6

5-2 THE ANTENNA

The antenna plays a very important role in radio communication. Several points should be considered when selecting an antenna.

Requirement for Antenna

The antenna coupler will automatically tune on any frequency in the range from 1.6 to 23MHz to a wire and/or a whip antenna having a total length of 6 to 15 meters. Though a longer antenna is preferable when the radio is operated only on low frequencies, it is recommended to use this size of antenna to ensure stable automatic tuning on all bands.

The antenna should be erected as high as possible, well in the clear, away from any object which may affect its performance, such as back stays, metallic masts, or derricks, etc.

Insulators should be of the highest quality and able to withstand leakage even when wet. Stays, metallic masts, etc. should be either effectively grounded or insulated.

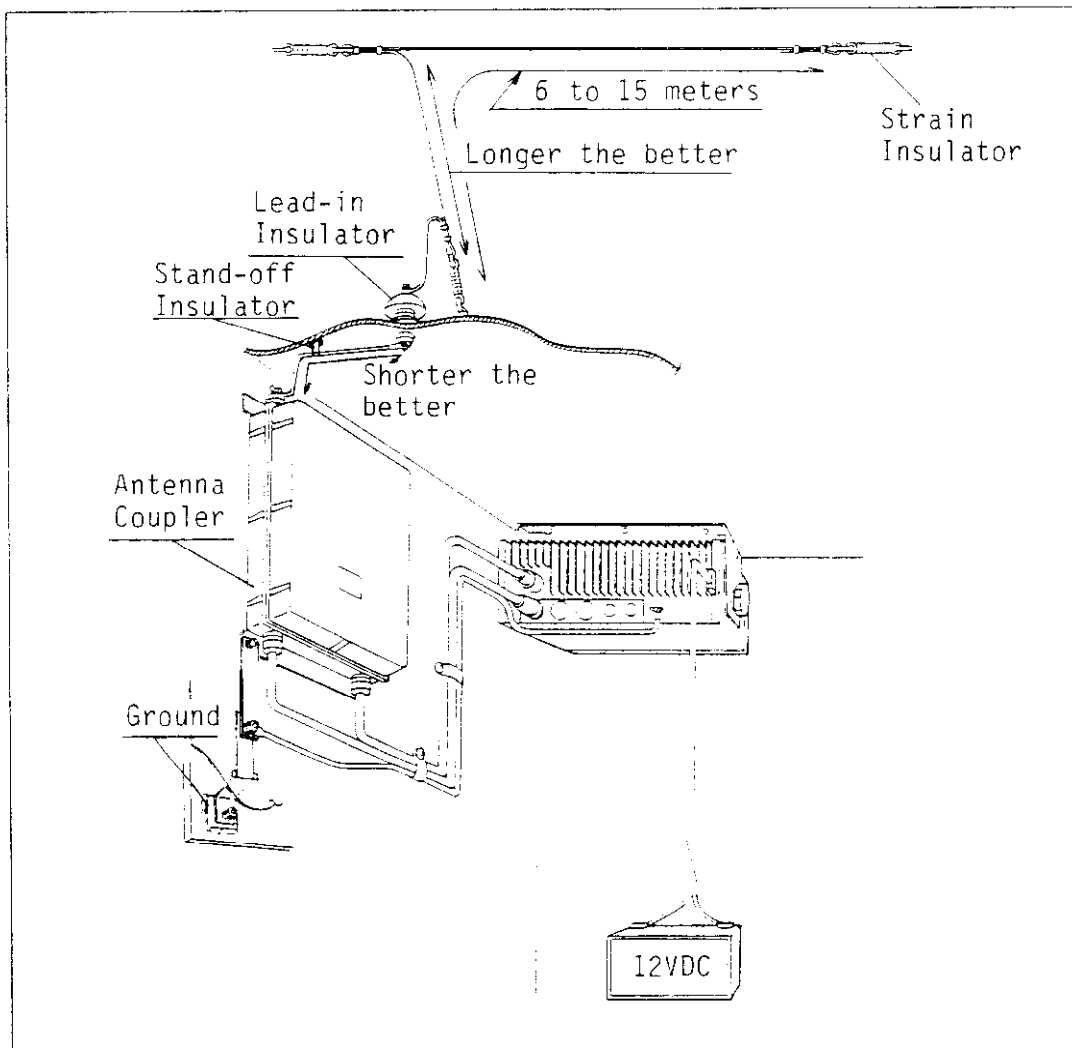
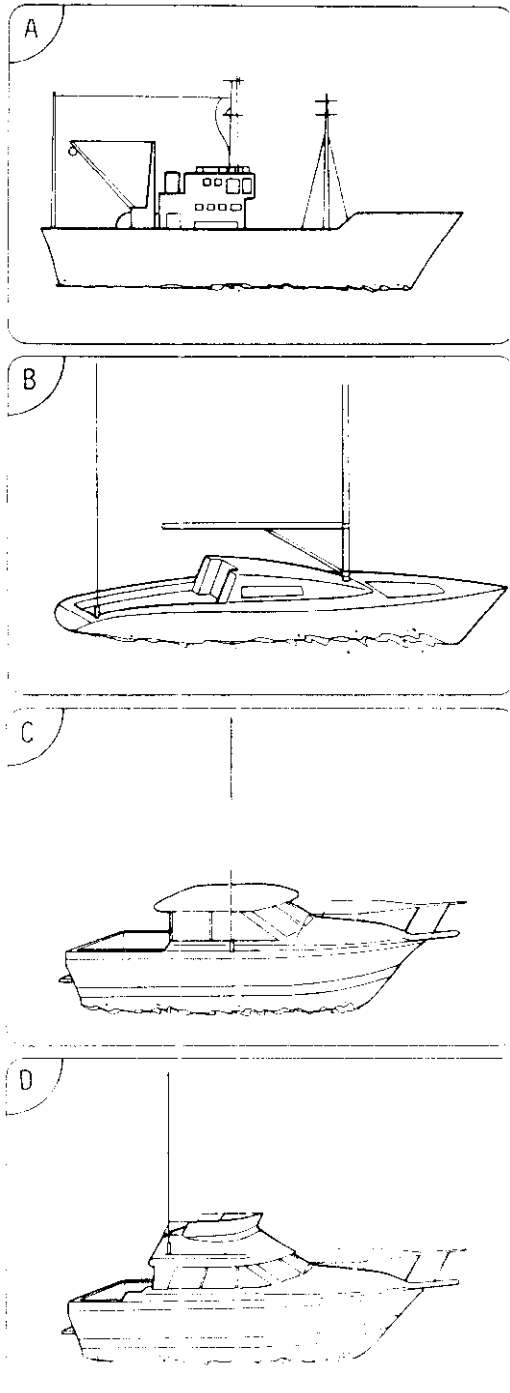

Fig. 5-1 Typical Installation of FS-1500

General Idea for Selecting Antenna



[SHIP STATION]

Fig. 5-1(A) shows the installation on a ship station, using a horizontal long wire antenna. The length of the horizontal wire should be between 7 and 15 meters. And the length of the vertical wire should no less than 5m, the longer the better for more effective transmission.

For sailboats and power boats, a whip antenna is preferable since it does not require much space.

For installation on a sailboat, the mounting location must be chosen carefully so as not to disturb deck fixtures. Keep the antenna clear of the spinnaker, jib, and of course the boom. Stay especially clear of the back stay. The taffrail is a good location in the event of dismasting, since the antenna won't be carried away. The best location, however, is atop the mast, the higher the better for effective communication. It is always a good idea to keep spare wire or an emergency antenna onboard in the event of dismasting.

On power boats, since there is no mast or deck fixture to worry about, selection of a mounting location is much easier. A whip antenna can be installed almost anywhere, again the higher the better. If your boat has a flybridge, install it there. And if it does not, install it atop the cabin.

Fig. 5-2

[FIXED STATION AND VEHICLES]

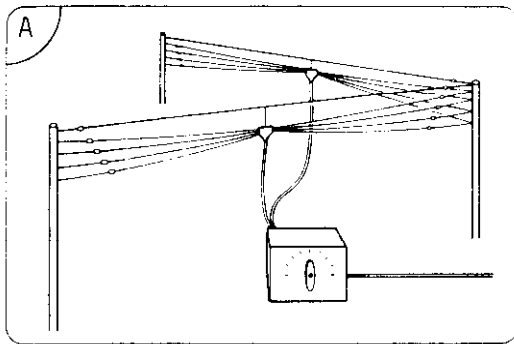

If the unit is to be operated as a fixed station, and if you do not need many frequencies, then you can use a doublet antenna. (In this case, the antenna coupler is not necessary.) This antenna is simple to extend and very effective, but note that the number of antennas must be equal to the number of working frequencies used. For this reason the use of doublet antennas is not practical if you are going to set up for multi-frequency operation, since many antennas will be required and switching among the antennas may be troublesome when a frequency is changed.

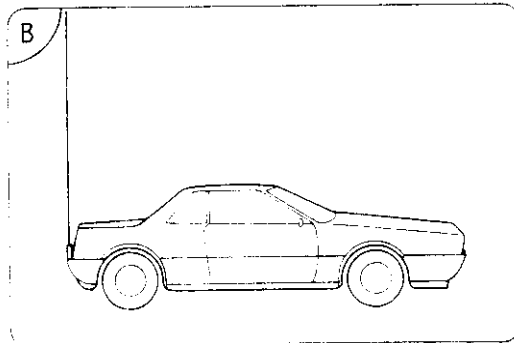

For vehicles, the antenna should be a 2.5 to 3m plain whip antenna (prepared locally). It may be installed on the bumper or an support arm bolted or welded to the chassis. The AT-1500 Automatic Antenna Coupler should be installed as near as possible to the base of the whip antenna.

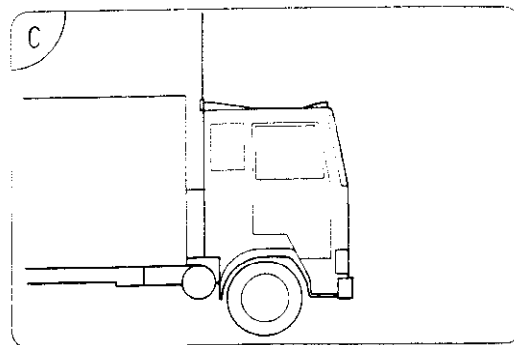

Ensure the mounting place is strong enough to support the antenna under conditions of continued vehicle movement. Do not install the antenna near the engine because of ignition noise. If the engine is computer controlled, ensure that the transmitting wave does not interfere with the control system of the engine control.

Fig.5-3

5.3 THE GROUND

The RF ground is an important factor for satisfactory operation of the radio. The overall efficiency of the radio can be related almost directly on a one-to-one basis to the efficiency of the grounding system. It is of the utmost importance to ground the antenna coupler unit. Keep in mind that without a good ground an SSB radio cannot work satisfactorily.

For the AT-1500, use a copper strap (5 to 10cm) and connect it between the ground terminal on the AT-1500 and a grounding bolt or a copper plate on the ship.

For Metallic Hulled Boats

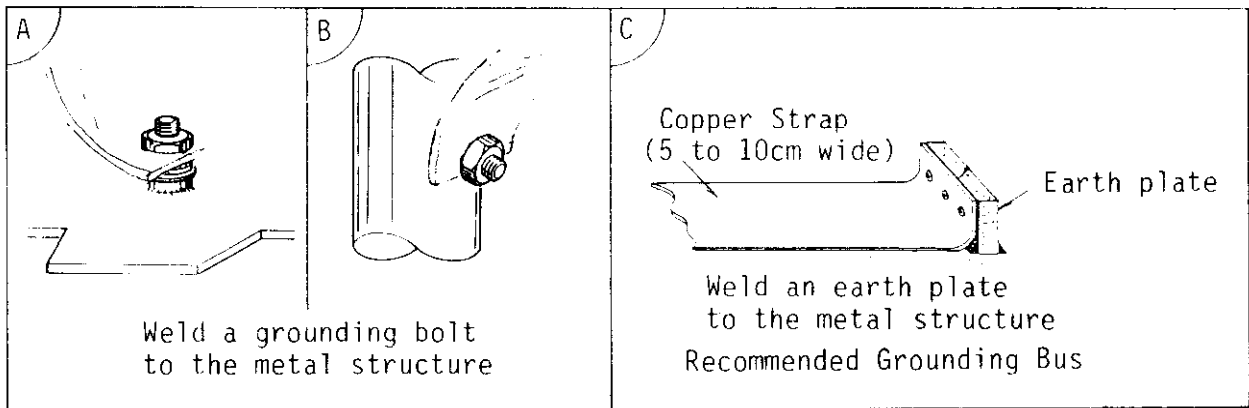

Fig. 5-4 Recommended Ground for Steel-hulled Boat

For Non-metallic Hulled Boats

When good RF ground is not provided, It is recommended to run more than 20cm wide copper plate from the outside of the boat to the ground terminal of the antenna coupler. See Fig. 5-5A.

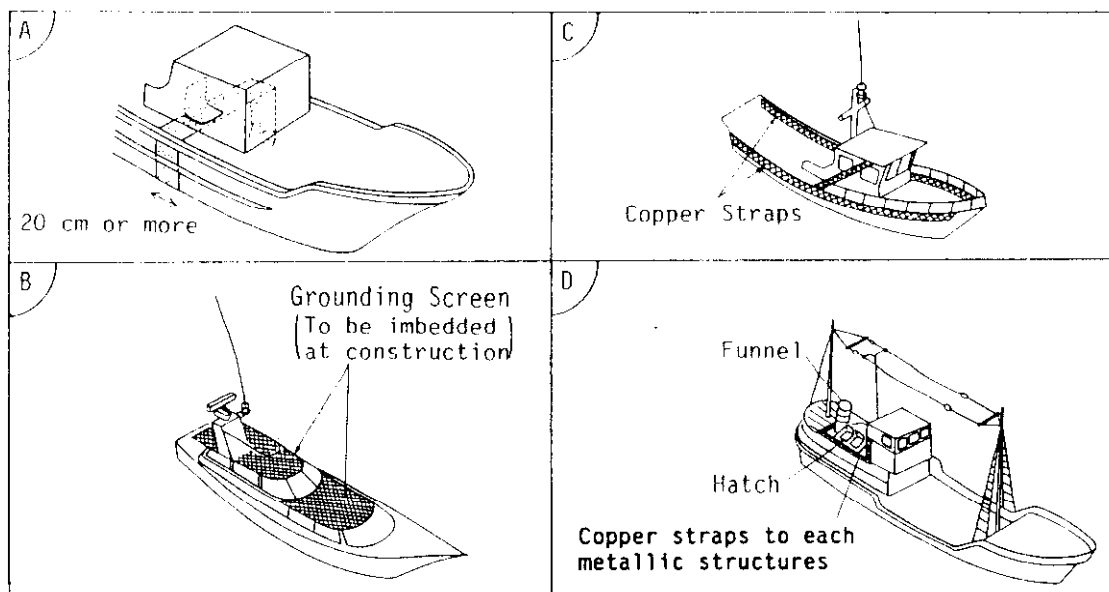

Fig. 5-5 Recommended Ground for Non-metallic-Hulled Boat

If there is no copper ground plate from the outside, then secure more than 3 square meters of copper foil or copper mesh, or connect metal structures with a 5cm wide copper strap. Copper strap will work quite well but never use ordinary wire; good ground can not be ensured. The structures listed below, when connected radially by copper straps, create an effective ground below the waterline.

- Lead keel
- Metal fuel tank
- Metal water tank
- Hydraulic steering system
- Engine block
- Rigging
- Hand rails
- Metal oil-catch tank

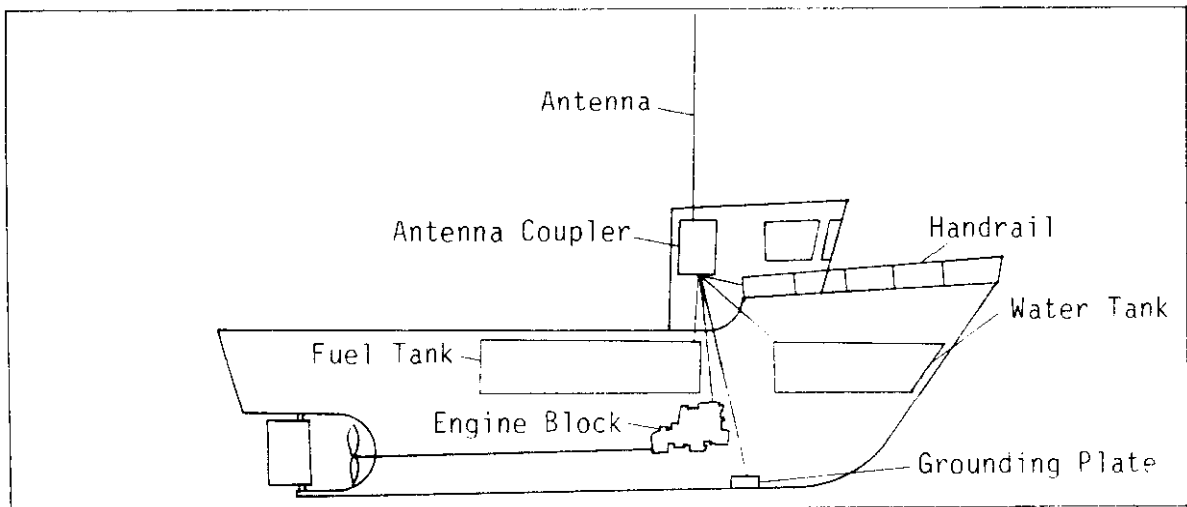
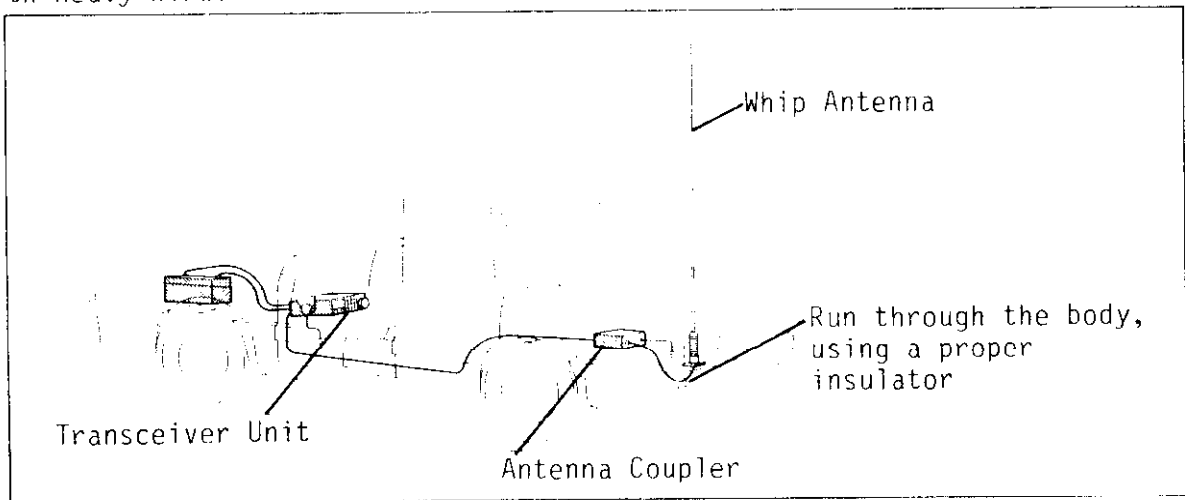

Fig. 5-6 Radial Grounding Using Copper Straps

For Land Vehicles

For Land Vehicles ground the antenna coupler and the transceiver unit to the chassis. Scratch the surface of grounding points to take off paint on it. Securely connect the ground terminals of the coupler to the grounding point with heavy wire.



NOTE: The power lines for this radio are isolated from the ground terminal and chassis.

Fig. 5-7 Ground for Land Vehicles

5.4 ANTENNA COUPLER INSTALLATION

The waterproof construction of the AT-1500 Antenna Coupler permits indoor or outdoor installation. It should be installed within 50 meters from the transceiver unit, as near as possible to the electrical ground. The Antenna Coupler is fixed horizontally or vertically with eight bolts(M6) and nuts, woodscrews, or U-bolts(option). When deciding the mounting place, the following points should be taken into account.

- 1) Select a place close to the antenna base.
- 2) Select a place where the efficient ground is easily taken.
- 3) Select a place where the antenna terminal is away from metallic structures or stays.
- 4) Select a place where water will not penetrate inside the coupler.
- 5) Select a place where the coupler is not exposed to direct water spray.
- 6) Select a place where it is easy to maintain, but avoid the place where it may interfere with crew or passengers.

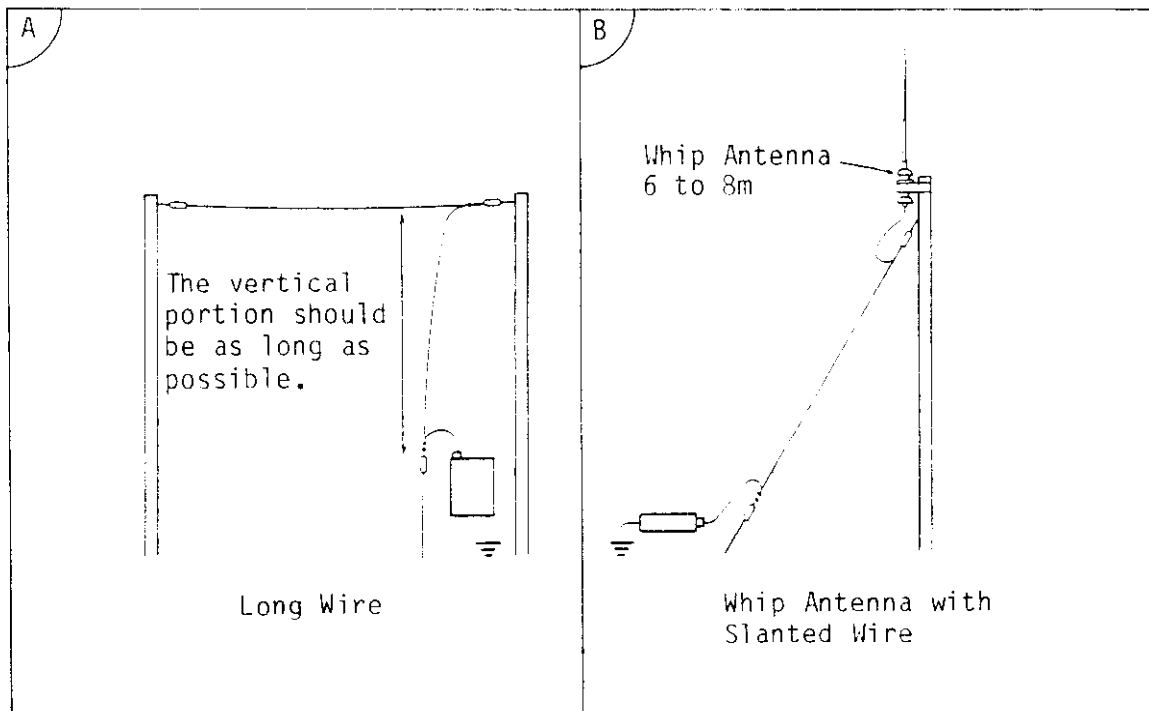

Fig. 5-8 Typical Installation of Antenna and Antenna Coupler

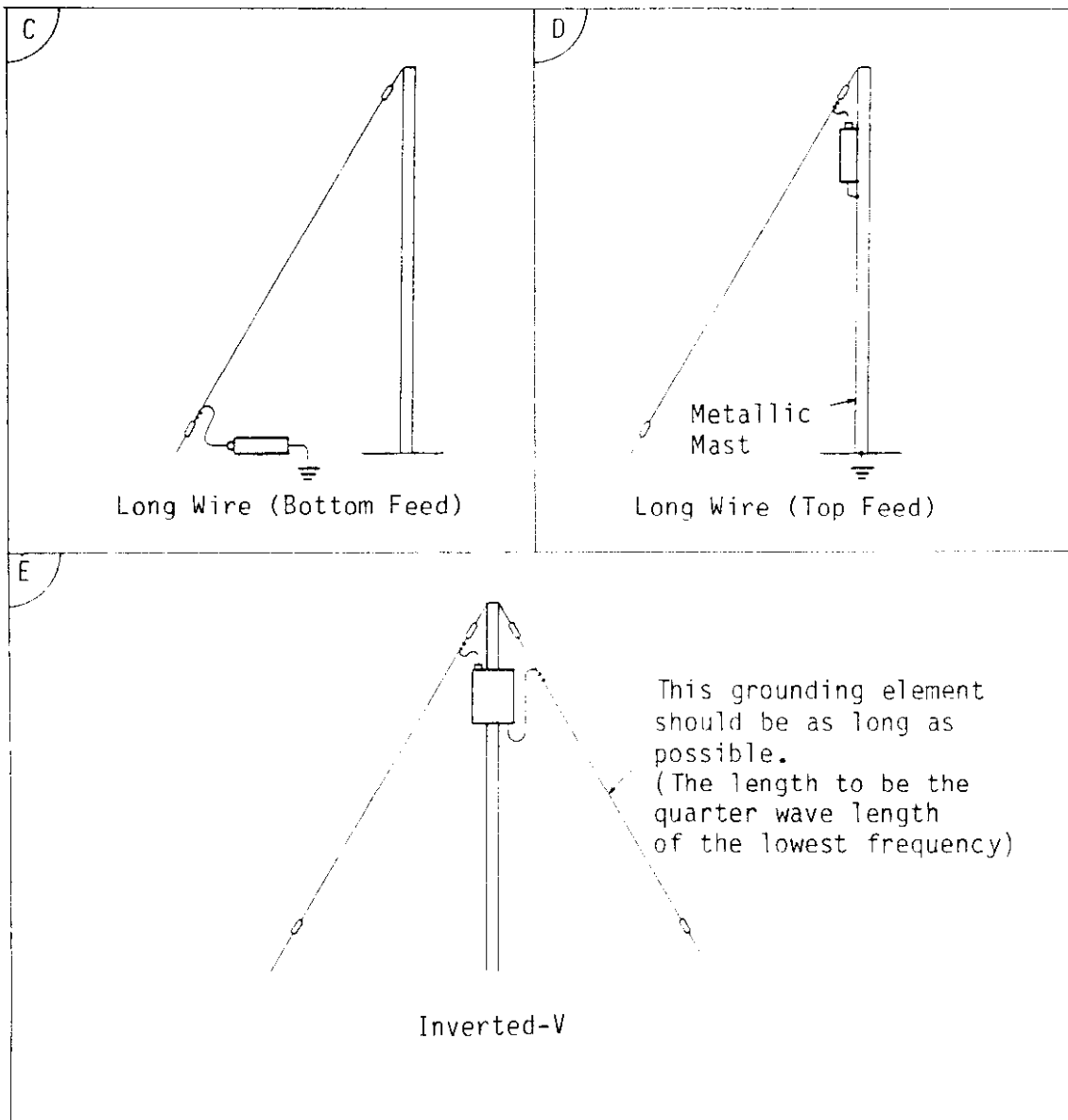

Fig. 5-9 Typical Installation of Antenna and Antenna Coupler

Mounting the Antenna Coupler

This coupler can be installed either on the floor, on the bulkhead, on the ceiling or to the mast. See Figs. 5-10 and 5-11.

It can be fixed with tapping screws to thick boards or walls, with bolts and nuts to the thin boards and with U-bolts, supplied as option, to masts. But never install the coupler where you can not easily open the top cover for service.

You have to preset the coupler for 2182kHz after all the antenna, ground, and other cables are installed. When closing the cover, fit the gasket properly and tighten each bolt to the same amount of torque. If the bolt is not tightened properly, water may leak inside the coupler.

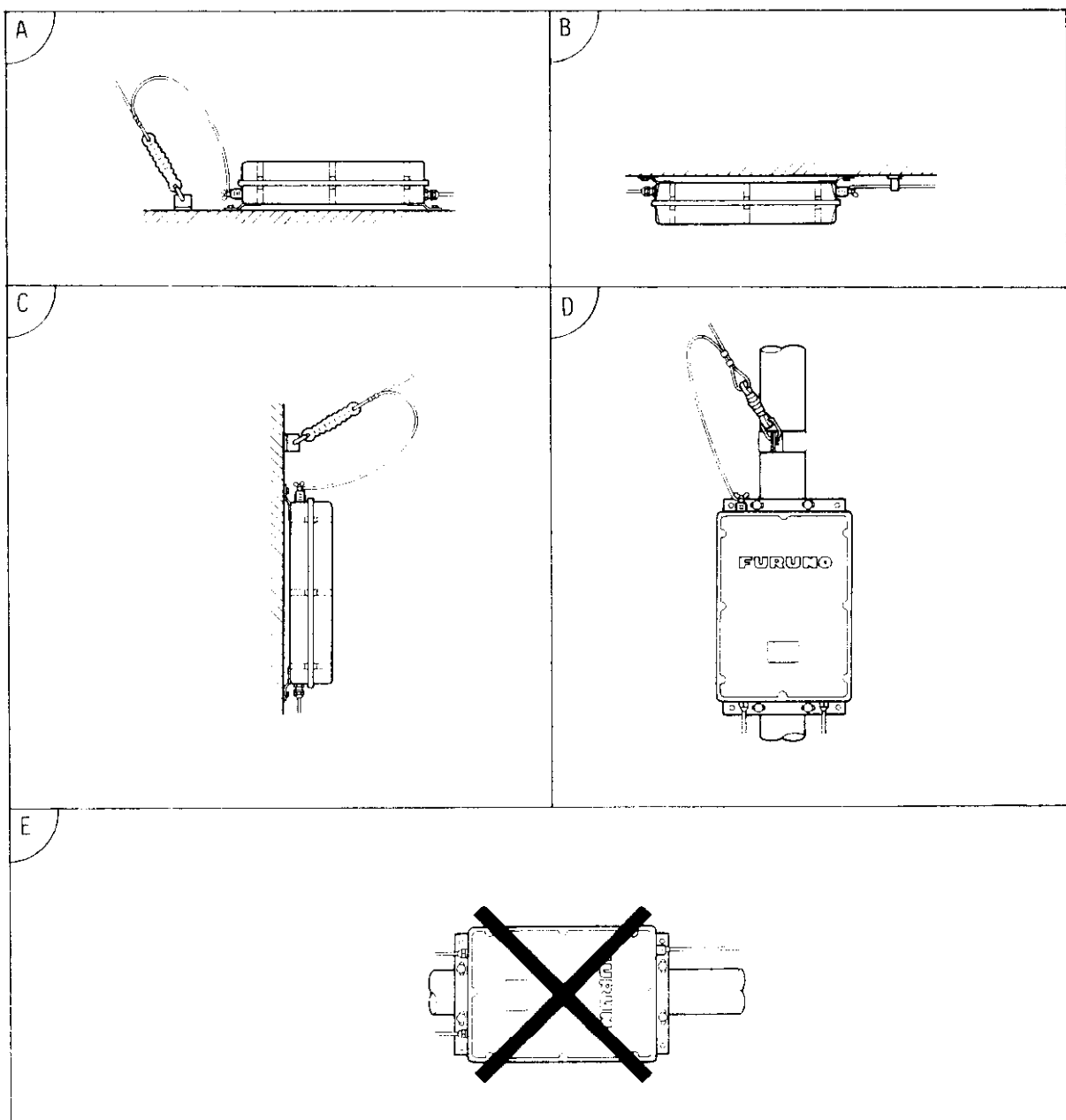

Fig. 5-10 Mounting the Antenna Coupler

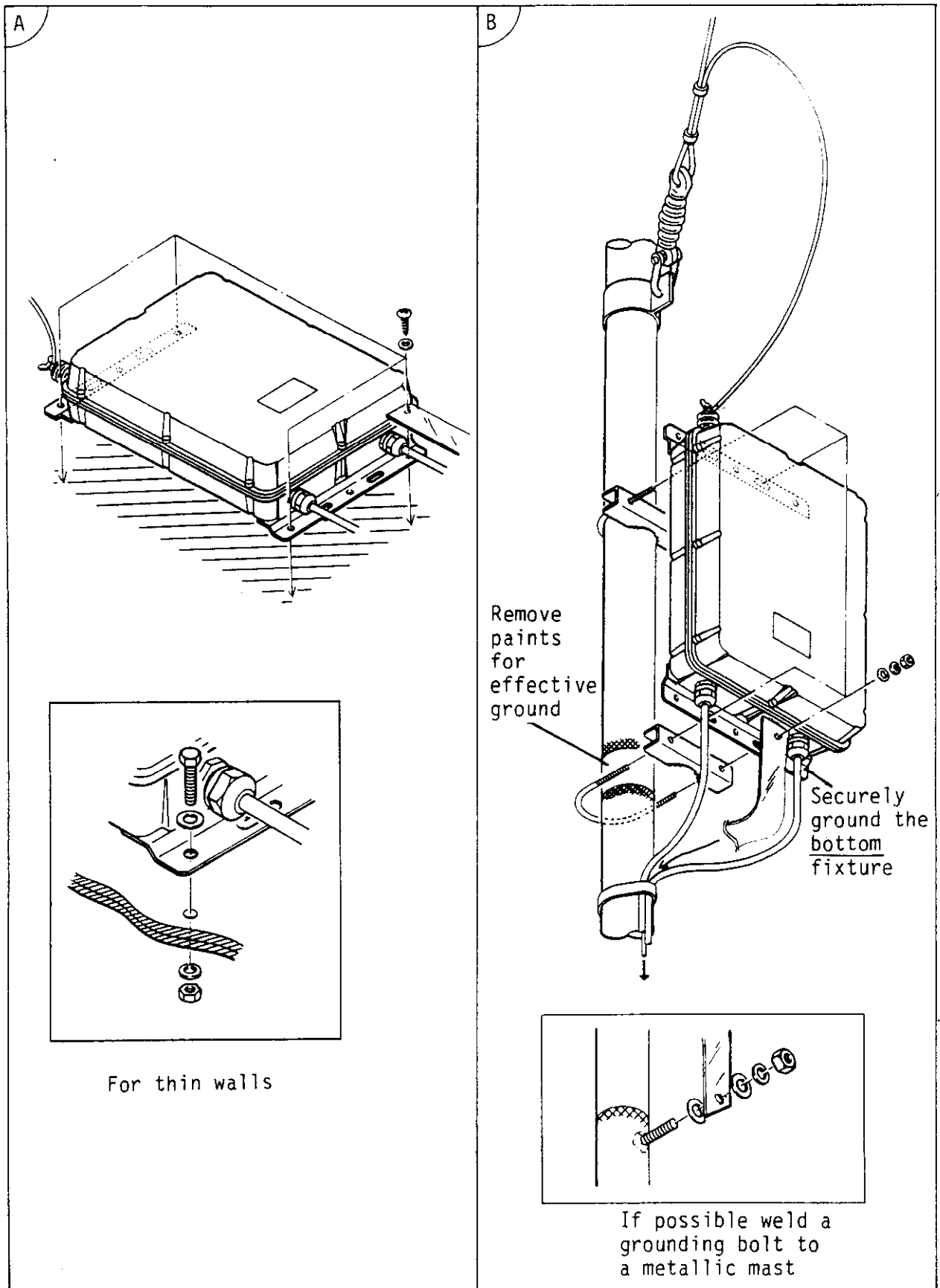

Fig. 5-11 Installing the Antenna Coupler

Anti-moisture Measure

When the coupler is installed outdoors, ventilation must be provided to allow trapped moisture to escape. Two drain holes are provided, one at the rear and one at the bottom, and one should be opened according to coupler installation method. If the coupler is installed horizontally, remove screw A and if installed vertically, remove screw B. This should be done before fixing the unit.

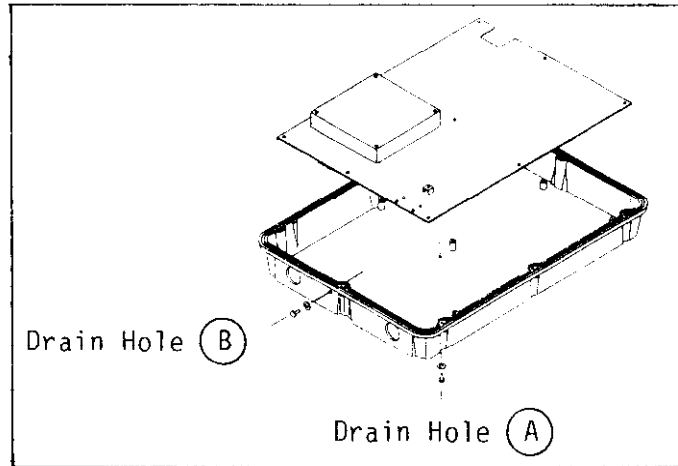

Fig. 5-12 Drain Hole

Connection of Antenna Wire to the Coupler

The antenna is connected to the antenna terminal of the Antenna Coupler. The insulator must be relieved from mechanical stress by using a short flexible wire between the insulator and a support. See Fig. 5-13.

When the Antenna Coupler is installed in the cabin on the boat, keep the length of the feeder as short as possible. A lead-in insulator should be used to pass the bulkhead, and it should be able to withstand high voltage. See Fig. 5-14.

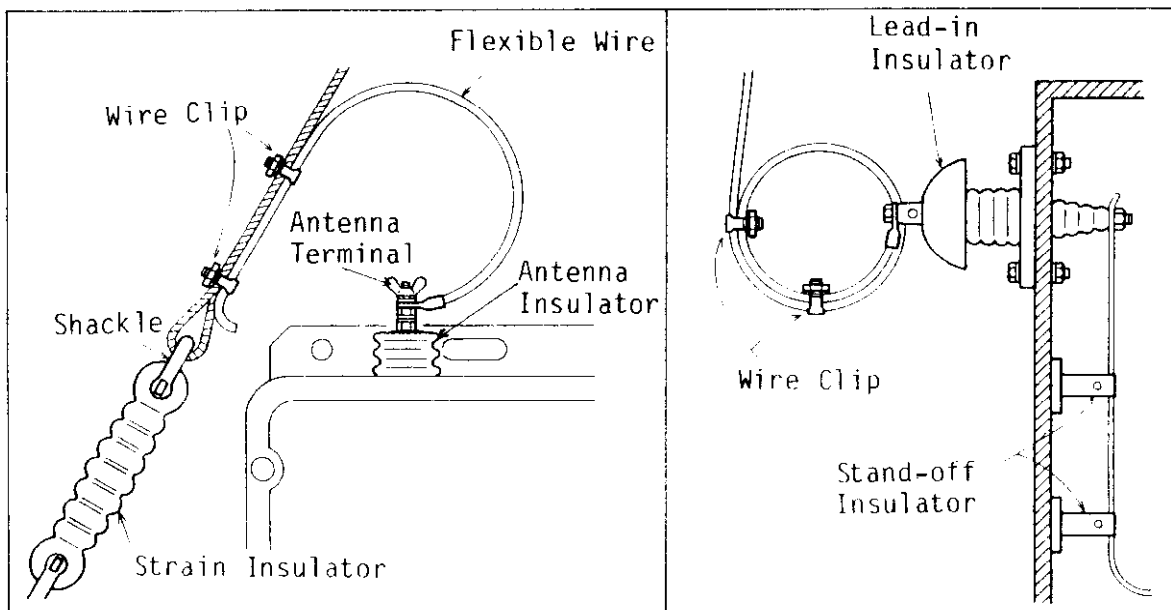

Fig. 5-13 Connection of Antenna Terminal

Fig. 5-14 Antenna Feed-thru Using A Lead-in Insulator

5.5 MOUNTING TRANSCEIVER

The hanger bracket supplied with the FS-1501 allows mounting overhead, on a tabletop, or on the bulkhead. Make sure the selected location is strong enough to support the unit under the conditions of continued vibration and shock normally encountered on the vehicle or boat. Where necessary, reinforce the mounting location by lining block or doubling plate.

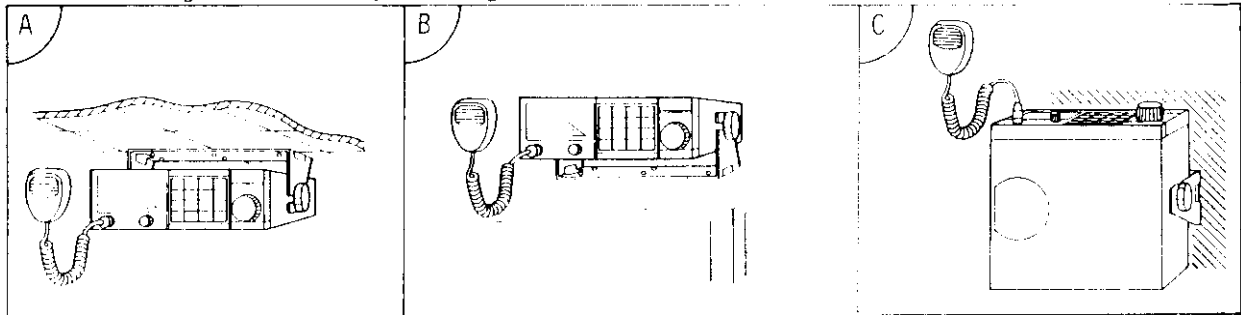

Fig. 5-15 Mounting Transceiver

Mounting Procedure

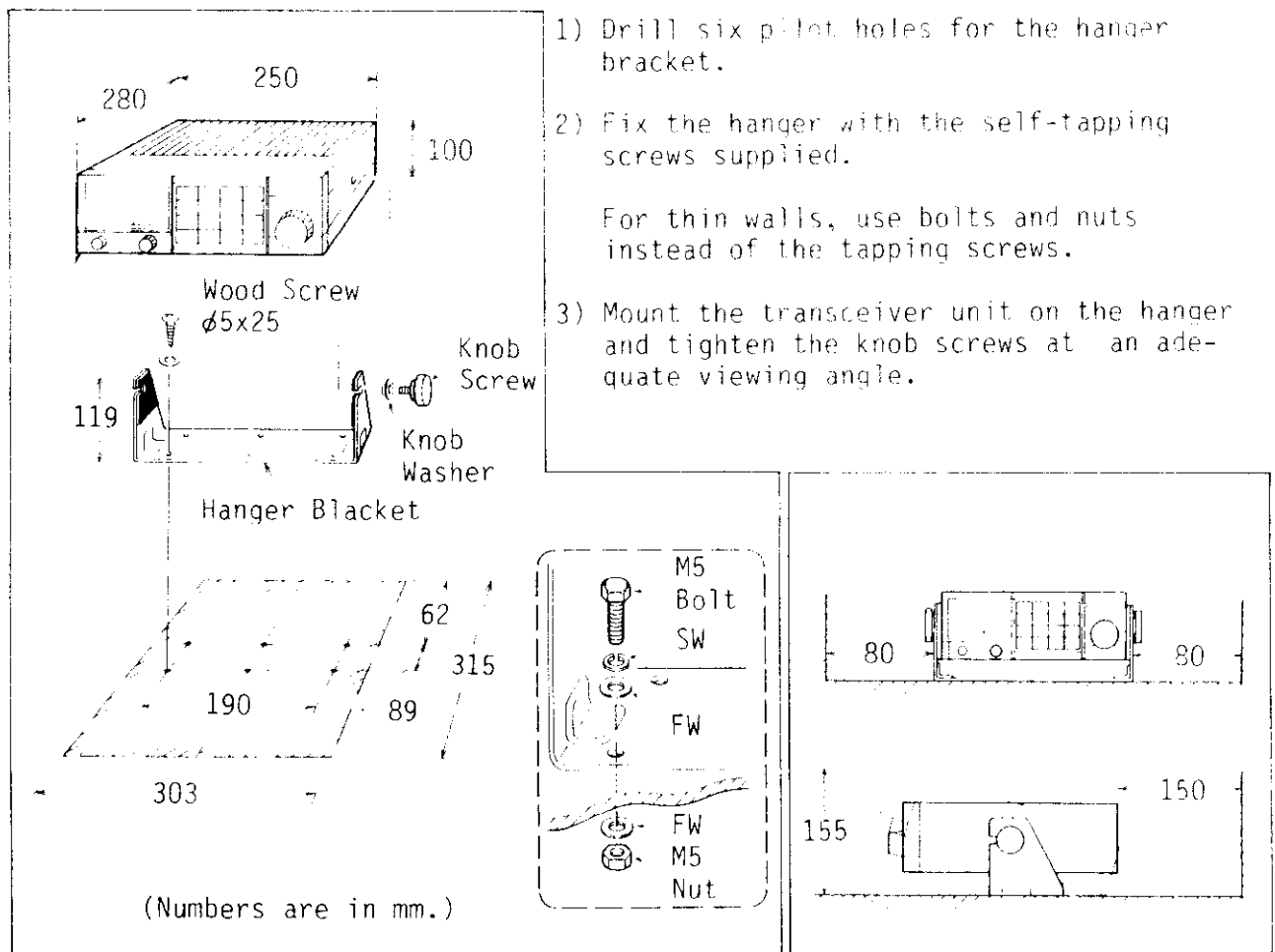

Fig. 5-16 Installing Transceiver

Fig. 5-17 Service Clearance

5.6 CABLE CONNECTION

Refer to the page 5-15 and wiring diagram on page S-1.

Description of Connectors

On the front panel of the transceiver, you can see a connector jack at the left lower side. This is for microphone connection. Each pin acts as follows. The numbers are read from the solder side of the connector plug.

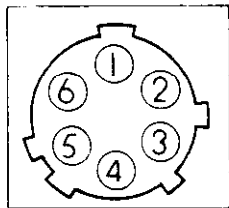

- | | | |
|----|--------|--|
| 1. | 0V | Connected to the ground. |
| 2. | PTT | Gets the transceiver ready to transmit. |
| 3. | MIC(+) | A path for microphone |
| 4. | MIC(-) | Connected to the ground. |
| 5. | PHONE | Received audio frequency output for handset. |
| 6. | +15V | Not used |

Fig.5-18 Pin Layout of the Microphone Connector Plug

Fig. 5-19 is the rear view of the transceiver. You can see eight terminals (connectors). The roles of each terminal are as follows. The pin numbers shown here are also read from the solder side of the connector plug.

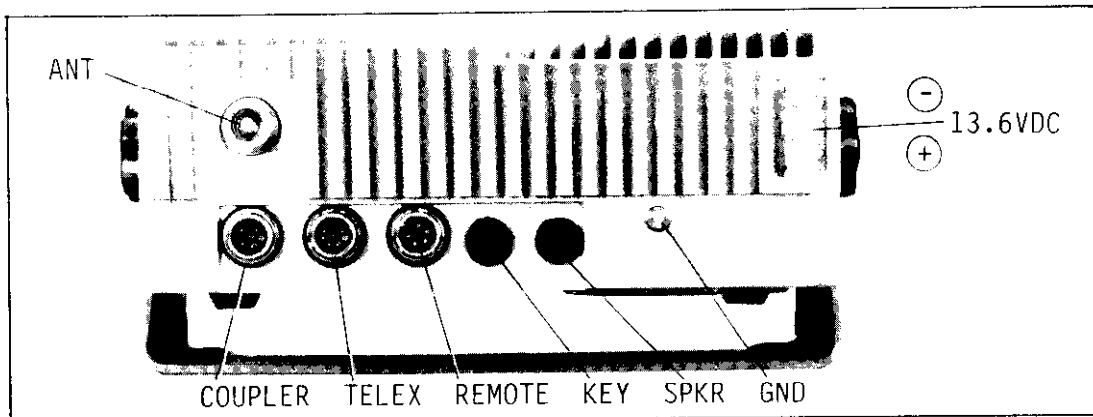
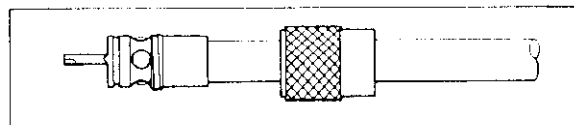

Fig. 5-19 Rear View of FS-1501

ANT is for antenna cable.



Coaxial Cable
Fig. 5-20

13.6VDC is for power supply

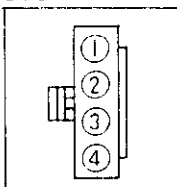

- | | |
|----|---------|
| 1. | RED (+) |
| 2. | RED (+) |
| 3. | BLK (-) |
| 4. | BLK (-) |

Fig. 5-21

GND is for grounding.

SPKR is for external speaker

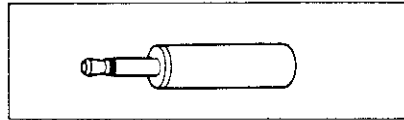

Pin Jack

Fig. 5-22

KEY is for telegraph key

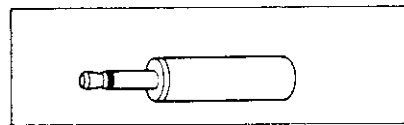

Pin jack

Fig. 5-23

REMOTE is for telex terminal (Thrane & Thrane Model 1600)

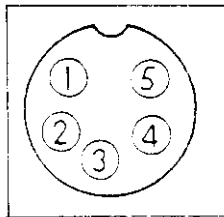

- | | | |
|----|-----|-----------------|
| 1. | TXD | Transmit Data |
| 2. | RTS | Request to Send |
| 3. | RXD | Receive Data |
| 4. | CTS | Clear to Send |
| 5. | OV | Common |

Fig.5-24

TELEX is for telex terminal.

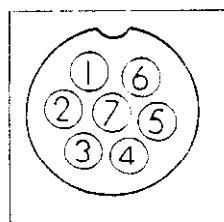

- | | | |
|----|-------------|---|
| 1. | OV | Connected to the ground. |
| 2. | SCAN STOP | Not used. |
| 3. | TLX BK | Gets the transceiver ready to transmit. |
| 4. | LINE OUT(+) | 0dBm/600 ohms audio output. |
| 5. | LINE OUT(-) | |
| 6. | LINE IN (+) | |
| 7. | LINE IN (-) | 0dBm/600 ohms audio input. |

Fig. 5-25

COUPLER is for antenna coupler.

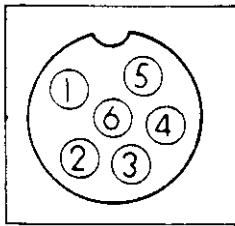

Fig. 5-26

- | | |
|-------------|---|
| 1. RED +15V | +15V is supply for Antenna Coupler. |
| 2. BLK 0V | Return line of +15V. |
| 3. ORG TUNE | Signal to start tuning. |
| 4. YEL BUSY | Signal to tell it is in tuning sequence. |
| 5. GRN IANT | Transfers antenna current to transceiver. |
| 6. BLU THRU | Signal to shortcut the coupler for reception. ("Shortcut" can be selected only on 1.6 to 3.9MHz.) |

NOTE : While using a resonant antenna like doublet antenna, and Antenna coupler is no use, then turn DIP S17 No.6 (on the CPU Board, see page 4-1) to OFF position.

5.7 WIRING

A control cable and 50 ohm coax. cable are used to connect the transceiver unit with the antenna coupler unit. 10m control cables are supplied as standard, however longer cables are optionally supplied. Not only the supplied cable but any other cable that satisfy the specifications (See page APA-1) may be used.

NOTE

- 1) To reduce the possibility of picking up noise, locate the cable as far as possible away from the following cables.
 - a) Separate 450mm or more from the cables of pulse generating equipment, i.e., radar, echo sounder, SCR controlled equipment.
 - b) Separate 50mm or more from other general power cables, e.g., cables of electric lights.
- 2) The length of the cable should be determined considering future maintenance ease.
- 3) Connection of wire to the clipper terminal in the antenna coupler should be using the tool provided inside the antenna coupler.

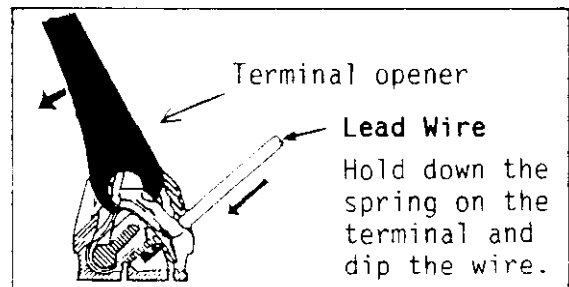
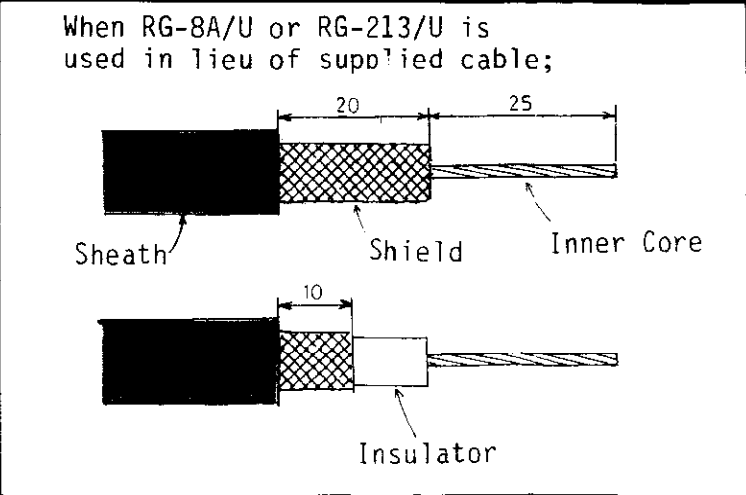
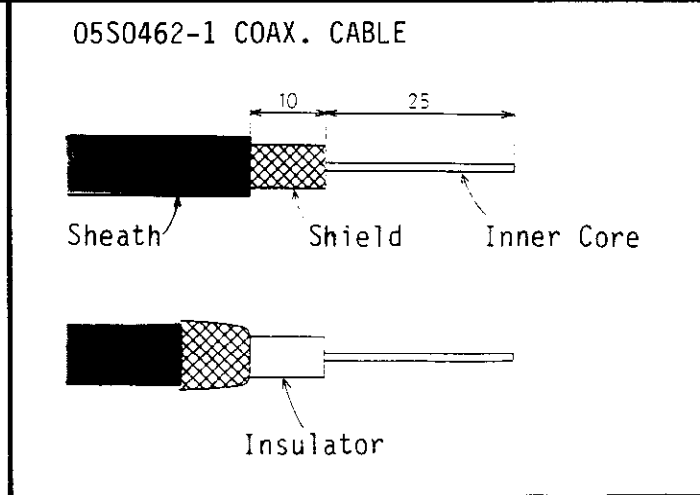
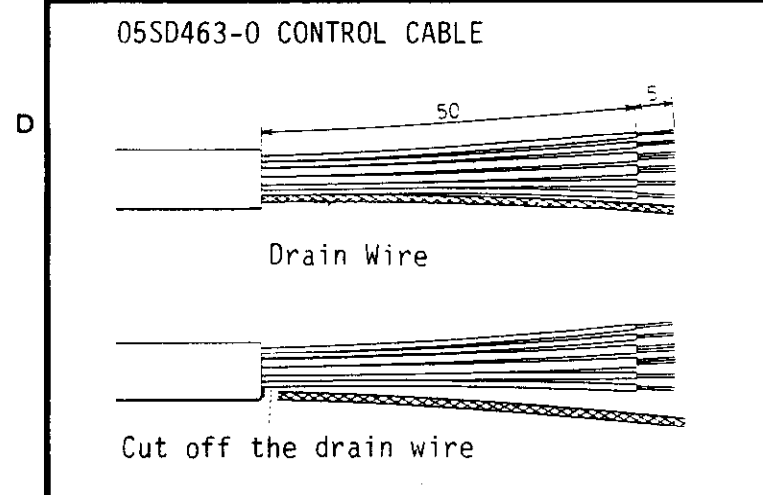
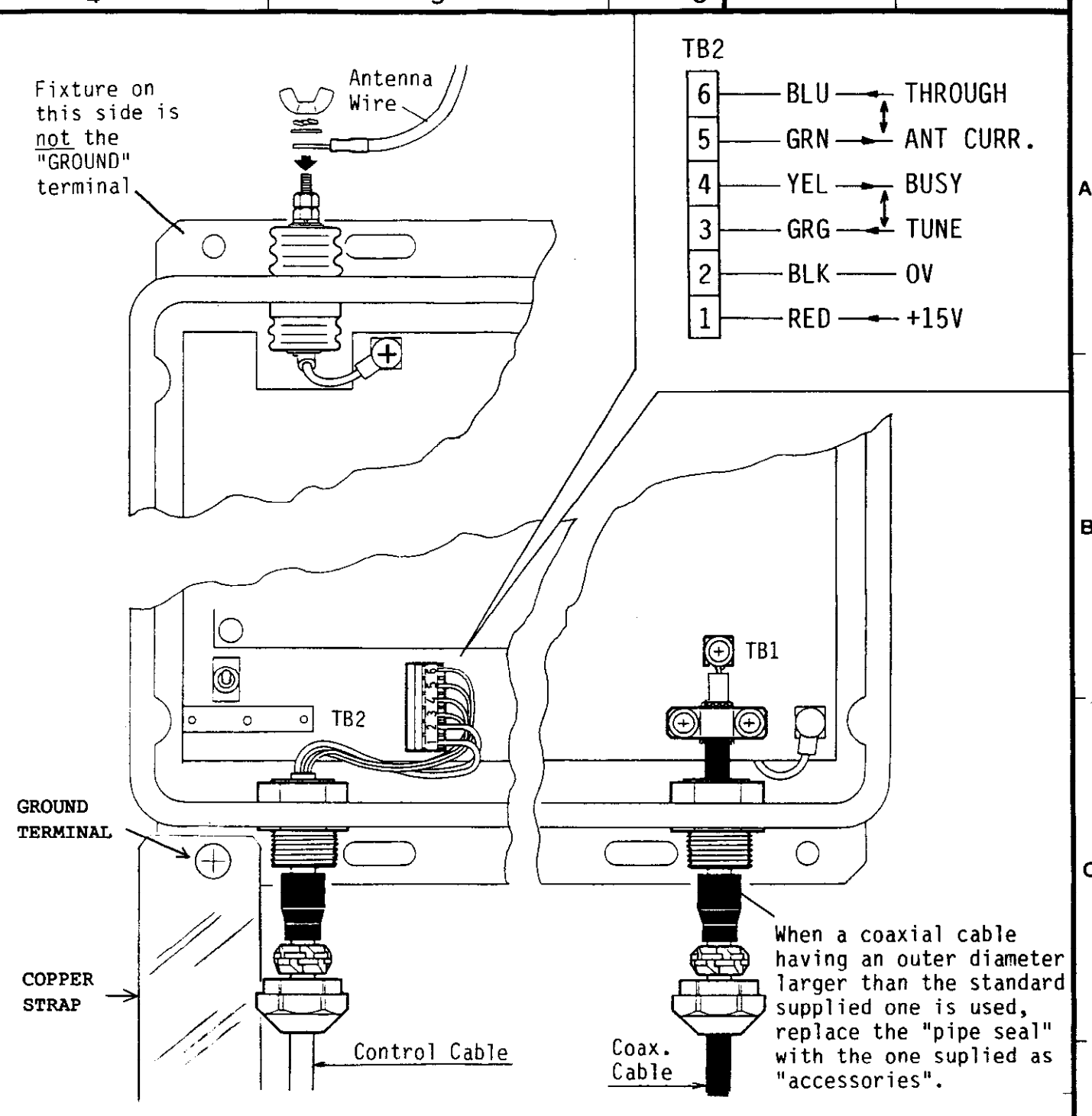
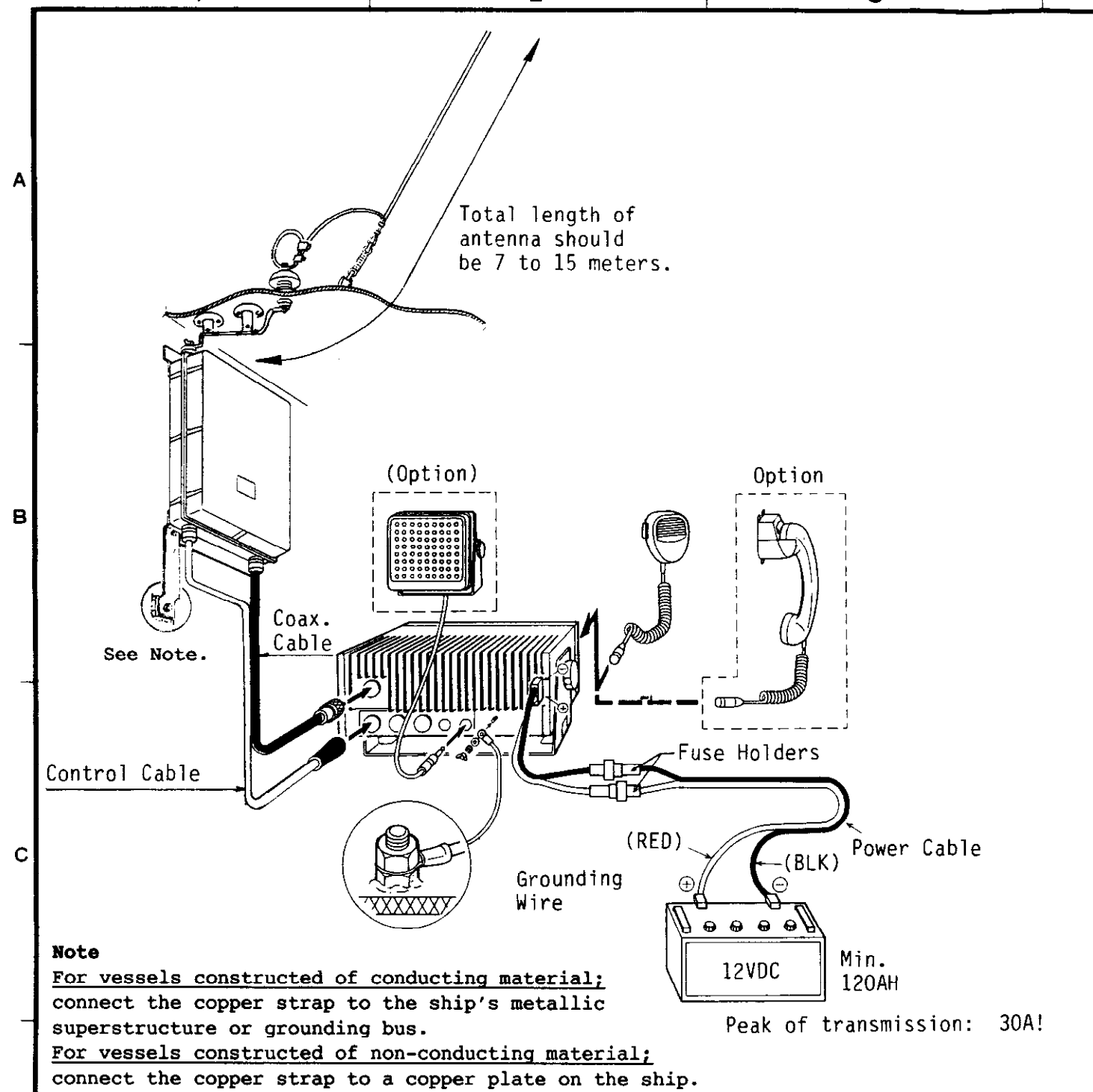

Fig. 5-24 Opening the Terminal



WIRING GUIDE FOR FS-1500 SERIES RADIOTELEPHONE

5.8 POST INSTALLATION CHECK

After wiring is completed, proceed (in order) to the following checks. These checks will ascertain whether the equipment was installed correctly or not and will prevent unexpected accidents. This includes the checks for Antenna Coupler.

Visual Check

Before turning on the radiotelephone, visually check the unit as follows.

Antenna

- 1) Are fixing bolts, wire clips, shackles securely tighten?
- 2) Are the antenna and/or coax. lead-in waterproofed ?
- 3) Is antenna wire surely connected to coupler?
- 4) Be sure that mechanical stress from the antenna is not applied to the terminal of antenna coupler.

Antenna Coupler Unit

- 1) Is the unit perfectly grounded using a copper strap?
- 2) Is the grounding strap short enough(within 2m)?
- 3) Is the drain hole open?
- 4) Are all wirings made correctly?

Transceiver Unit

- 1) Is the unit grounded with 3.5sq grounding wire?
- 2) Is the ground connection short enough?
- 3) Are all wirings made correctly?

Rectifier

- 1) Are the voltages written on the rectifier unit and ship's mains the same?

Supply Voltage Check

Make sure the power switch of the control unit is off and check that the voltage of the transceiver unit is within 13.6VDC \pm 15%.

Performance Check

If no problem was found in the checks above, then turn on the transceiver unit and check performance.

NOTE: Antenna tuning may be difficult if the antenna length is too long or too short. Adjust the length, if necessary.

a) Check by self-test

Check the antenna coupler unit by the self-test described in 3.2 SELF-TEST "CHECK OF RELAY"

b) Receiver check

Set the transceiver as follows and check that all the bands are received clearly.

Speaker-----	ON
Squelch-----	OFF

If the receiving signal is too low or there is too much noise then return to "Visual Check" and recheck. Double check the antenna and ground. If there is no trouble proceed to the next step.

c) Transmitter check

Check if "TUNE ok" mark is displayed and automatic tuning is executed when the [TUNE] key or the press-to-talk switch is pressed on each band.

It is designed not to take more than 15 sec. for automatic tuning. So if you find a frequency which takes more than 15 sec. then check the length of the antenna. It might be too long or too short. "Good length" may be found if the antenna is shortened or lengthened by about 2 meters.

5-9 MANUAL 2182kHz SETTING

Regulation require that 2182kHz be tunable either automatically or manually. The setup to enable manual tuning in the event the antenna tuner system fails is made with DIP switches in the antenna coupler. (See "Chapter 4 PARTS LOCATION" for the location of components.)

- 1) Turn on the power of the transceiver unit.
- 2) Open the cover of the Antenna Coupler Unit.
- 3) Set toggle switch S3 to "AUTO" position.
- 4) Tune the coupler by hitting the [2182] key on the transceiver unit.

The relays should chatter for a short period and then become silent.

- 5) Record the on/off status of the light emitting diodes (LEDs) CR33 thru CR52.
- 6) Set toggle switch S3 to "MANUAL(2182)" position.
- 7) Set the DIP switches S4, S5 and S6 so that the LEDs are lit or extinguished in the same pattern as recorded in step 5) above.

DIP Switch S4	DIP Switch S5	DIP Switch S6
No.1 - CR 33	No.1 - CR 41	No.1 - CR 49
No.2 - CR 34	No.2 - CR 42	No.2 - CR 50
No.3 - CR 35	No.3 - CR 43	No.3 - CR 51
No.4 - CR 36	No.4 - CR 44	No.4 - CR 52
No.5 - CR 37	No.5 - CR 45	
No.6 - CR 38	No.6 - CR 46	
No.7 - CR 39	No.7 - CR 47	
No.8 - CR 40	No.8 - CR 48	

- 8) After setting the DIP switches toggle S3 between "AUTO" and "MANUAL (2182)" several times to make sure the status of the LEDs do not change. If they change, try 7) again.
- 9) Set S3 to "AUTO" position, and then replace the cover of the Antenna Coupler Unit.

5.10 Installation of VOX IC (Optional Supply)

Vox is "Voice Operating Control" and by using this you can transmit without pressing a PTT switch on the microphone. It will automatically transmit when you talk into the microphone.

How to Install the VOX

(Refer to page 4-1 for location of U16)

- 1) Find the IC installing place (U16) on the TX/RX Board (05P0272) and solder the IC into it.
- 2) Select "User Channel Mode" and recall Ch.92.
- 3) Press [ENT] key and confirm that "1" is displayed on LCD. IF not press [ENT] key again. Now the VOX operation is enabled.
- 4) Press [SEND/STOP] key to go back to normal operation.

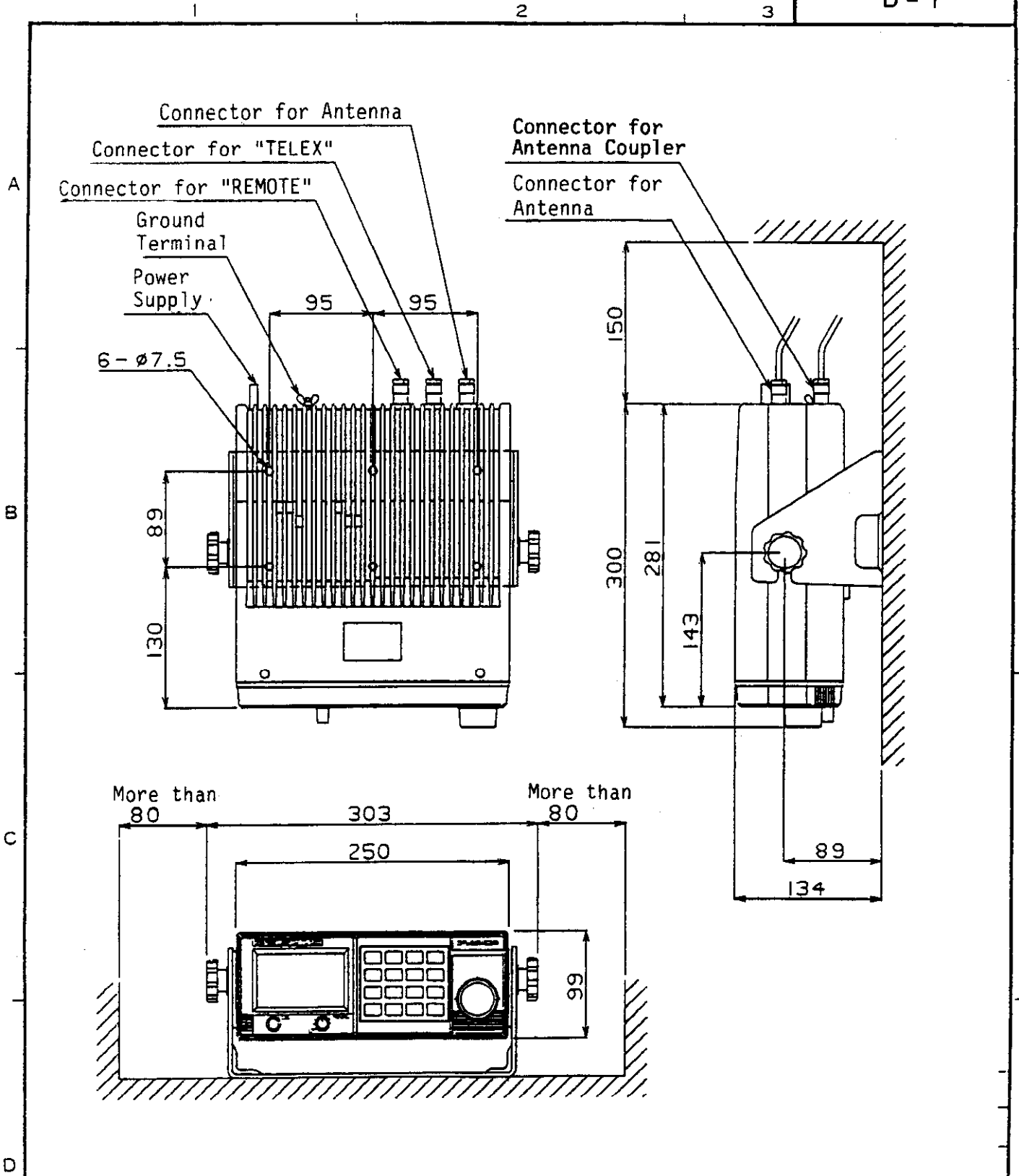

品番 ITEM	品名 NAME	材質 MATERIAL	数量 Q'TY	圖番 DWG.NO.	摘要 REMARKS
承認 APPROVED	三角法 THIRD ANGLE PROJECTION		名稱 TITLE FS-1500 SERIES		
檢閱 CHECKED	尺 SCALE	1/5	TRANSCEIVER UNIT OUTLINE		
製圖 DRAWN	重 WEIGHT	5.8 kg	圖番 DWG.NO. E5485-009-B		

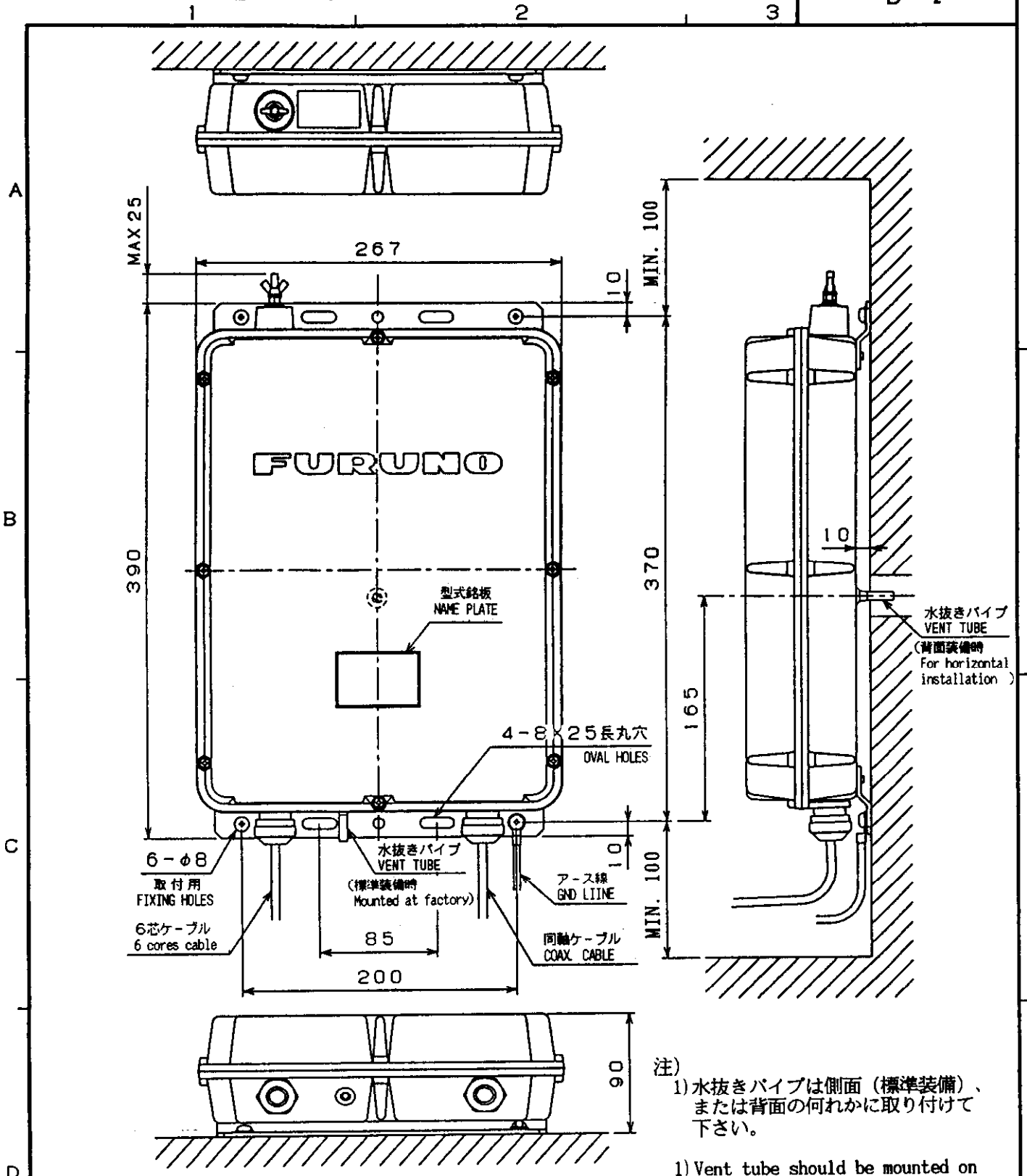

- 注)
 1) 水抜きパイプは側面 (標準装備)、または背面の何れかに取り付けて下さい。
 1) Vent tube should be mounted on either bottom (factory mount) or rear of the coupler, depending on installation methods.

品番 ITEM	品名 NAME	材質 MATERIAL	数量 Q'TY	図番 DWG.NO.	摘要 REMARKS
承認 APPROVED	NOV. 22 '91 T. NAKANO	三角法 THIRD ANGLE PROJECTION		名称 TITLE アンテナカップラ外寸図 AT-1500/AT-1502	
検 CHECKED	NOV 20 '91 M. IKEDA	尺 SCALE	1 / 4	ANTENNA COUPLER	
製 DRAWN	NOV. 20 '91 Y. HAMADA	重 WEIGHT	2.9 kg	図 DWG.NO.	C5485-010-E

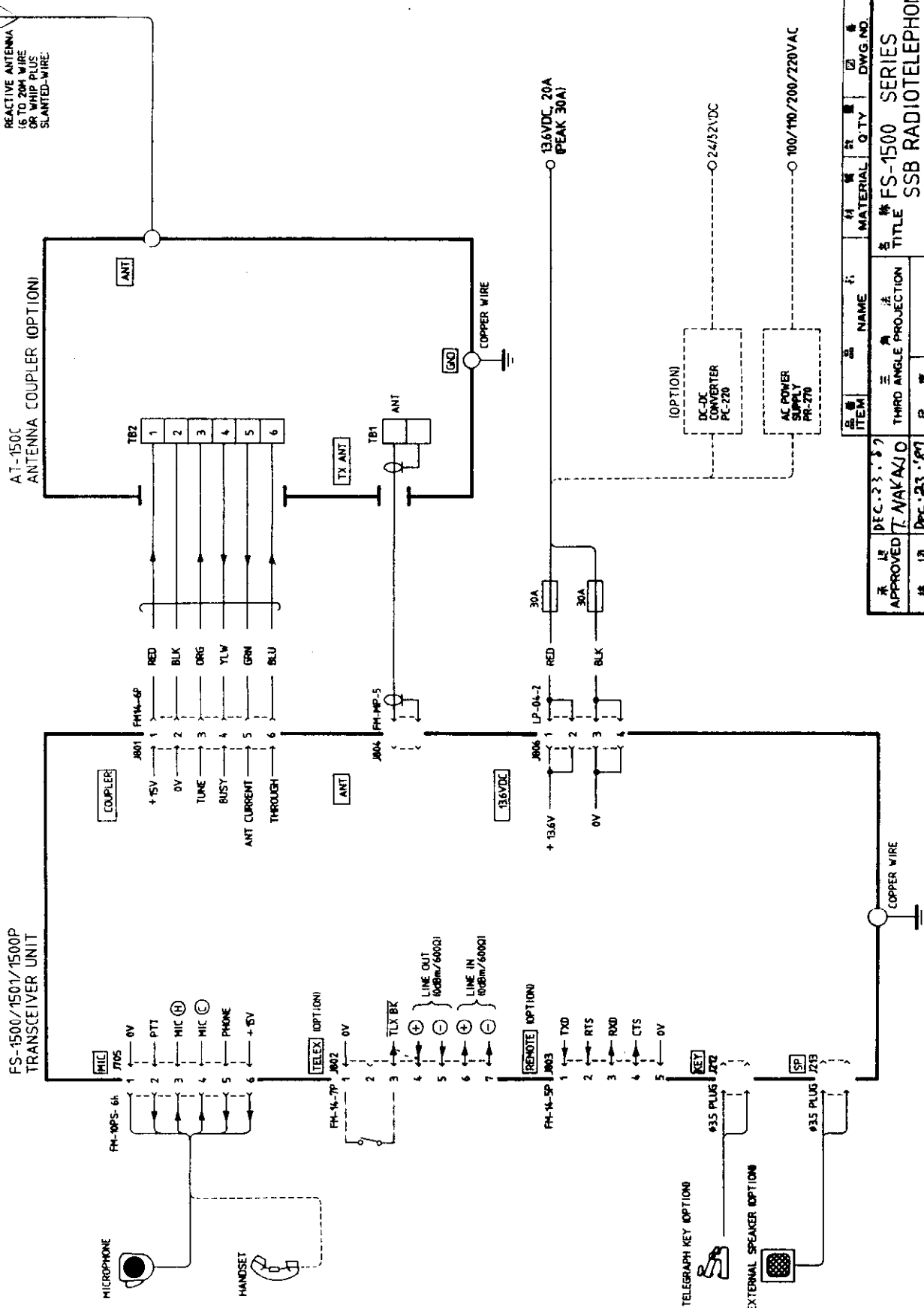

ITEM	NAME	MATERIAL	QTY	DWG. NO.	REMARKS
DEC-23-87	APPROVED	T. NAKAJI			
DEC-23-87	CHECKED	M. IKEDA			
DEC-23-87	DRAWN	S. NISHI			

FS-1500 SERIES
SSB RADIOTELEPHONE
INTERCONNECTION DIAGRAM

DWG. NO. E 5 4 8 5 - 0 1 1 - C

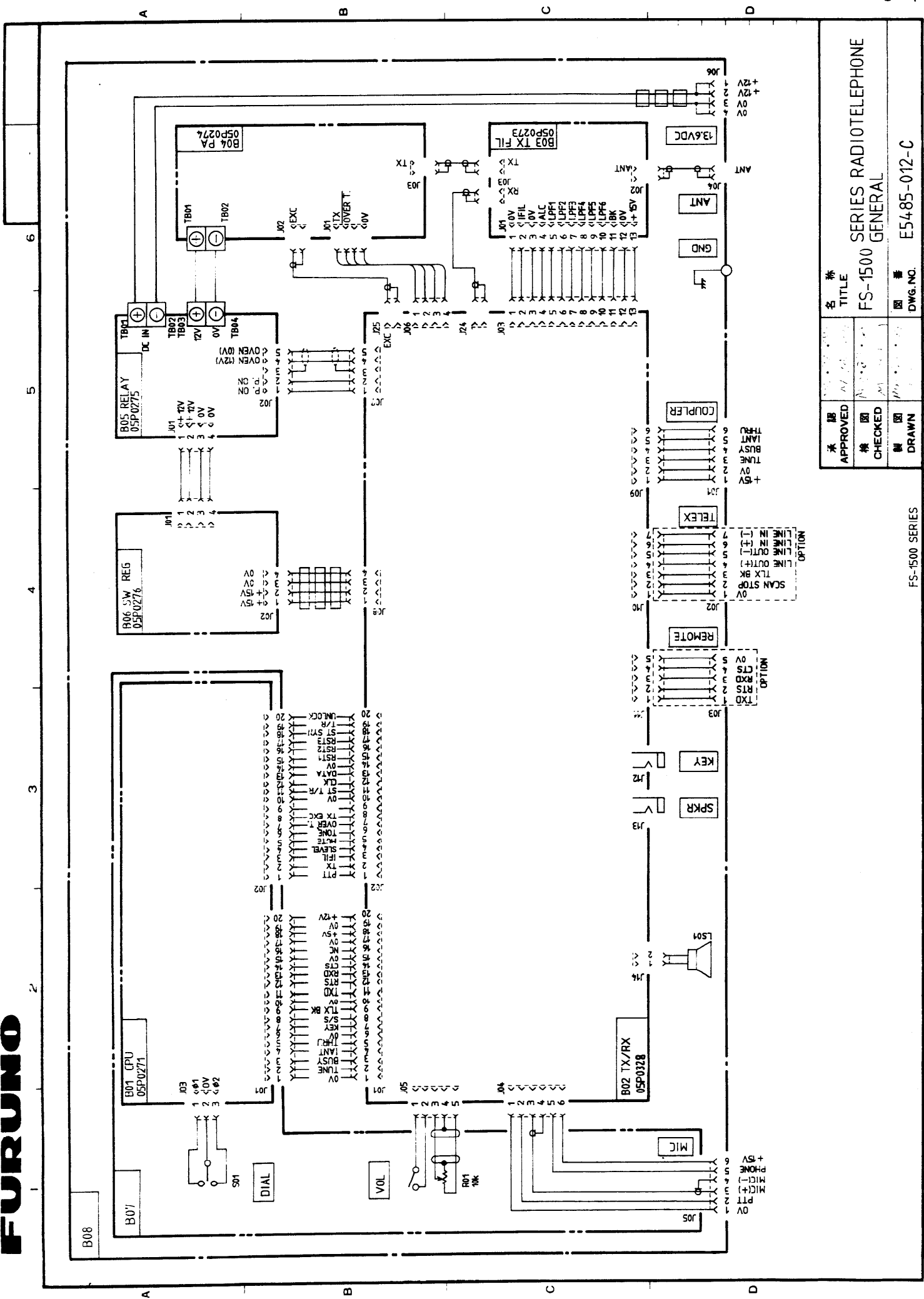

承認	名 稱
検 査	TITLE
製 図	FS-1500 GENERAL
製 図 番 号	FS-1500 SERIES
DRAWN	DWG. NO. E5485-012-C

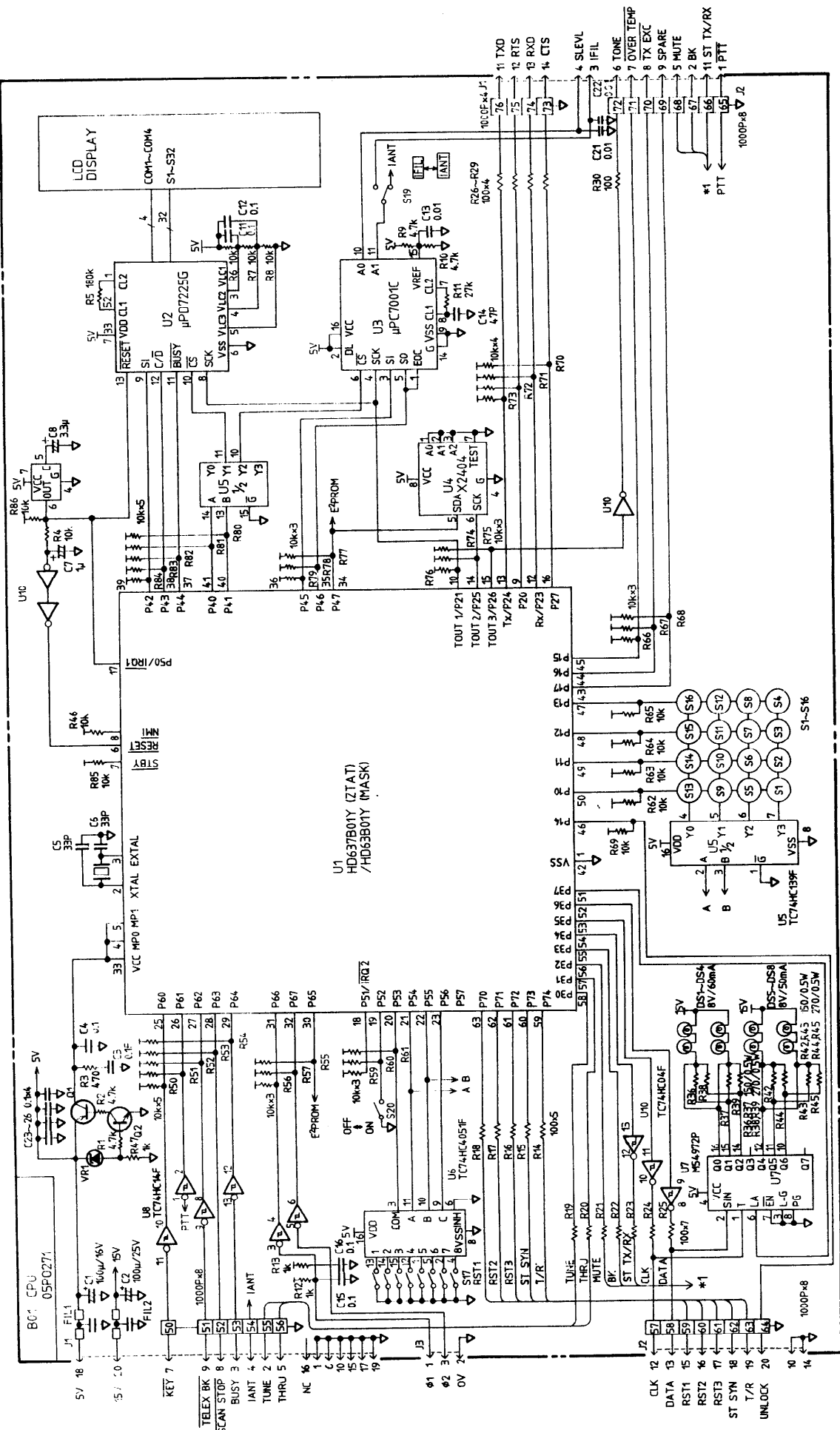

承認 APPROVED	名称 TITLE
検閲 CHECKED	B01 05P0271 CPU
製図 DRAWN	国番 DWG. NO.
	E5485-013-C

FS-1500 SERIES

FURUNO ELECTRIC CO., LTD.

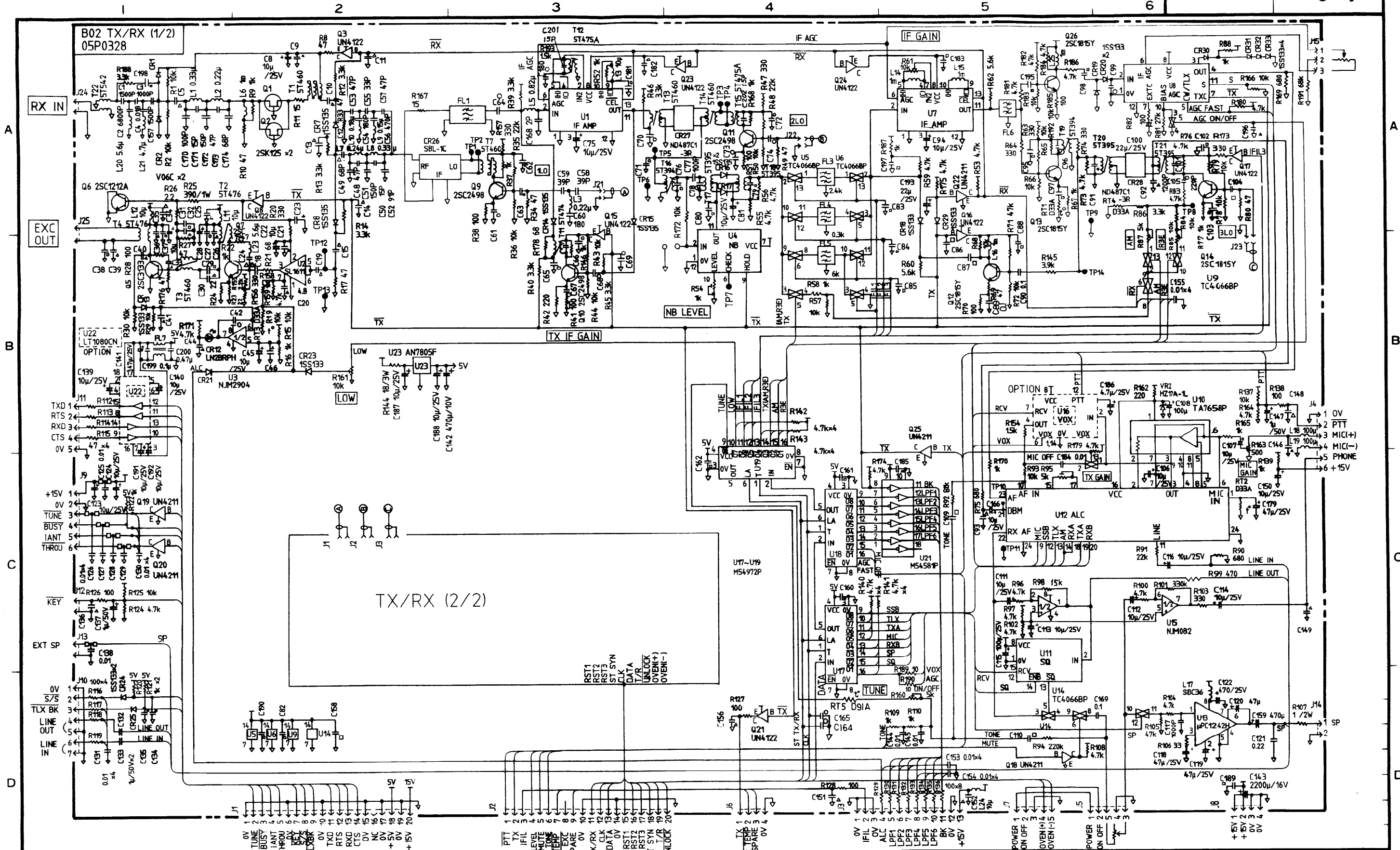

NOTE (1) RESISTORS ARE IN Ω (1/6W), CAPACITORS ARE IN F. INDUCTORS ARE IN H, UNLESS OTHERWISE NOTED.
 (2) MARKS ○ ARE 1000PF/50WV CAPACITORS, △ ARE 0.01μF/50WV AND □ ARE 0.1μF/25WV CAPACITORS.

PCB NO.	R189	R190	CONNECTION TO J15	AGC	VOX	USED FOR;
05P0328A	×	○	RF GAIN POT.	ON/OFF	×	FS-1550
05P0328B	○	×	JUMPER LINK (#1 ↔ #3)	ALWAYS ON	ON IF VOX IC IS MOUNTED	FS-1500 FS-1501

承認 APPROVED	名称 TITLE B02 05P0328 TX/RX (1/2) 図番 DWG. NO. E5510-003-G
検印 CHECKED	
製印 DRAWN	

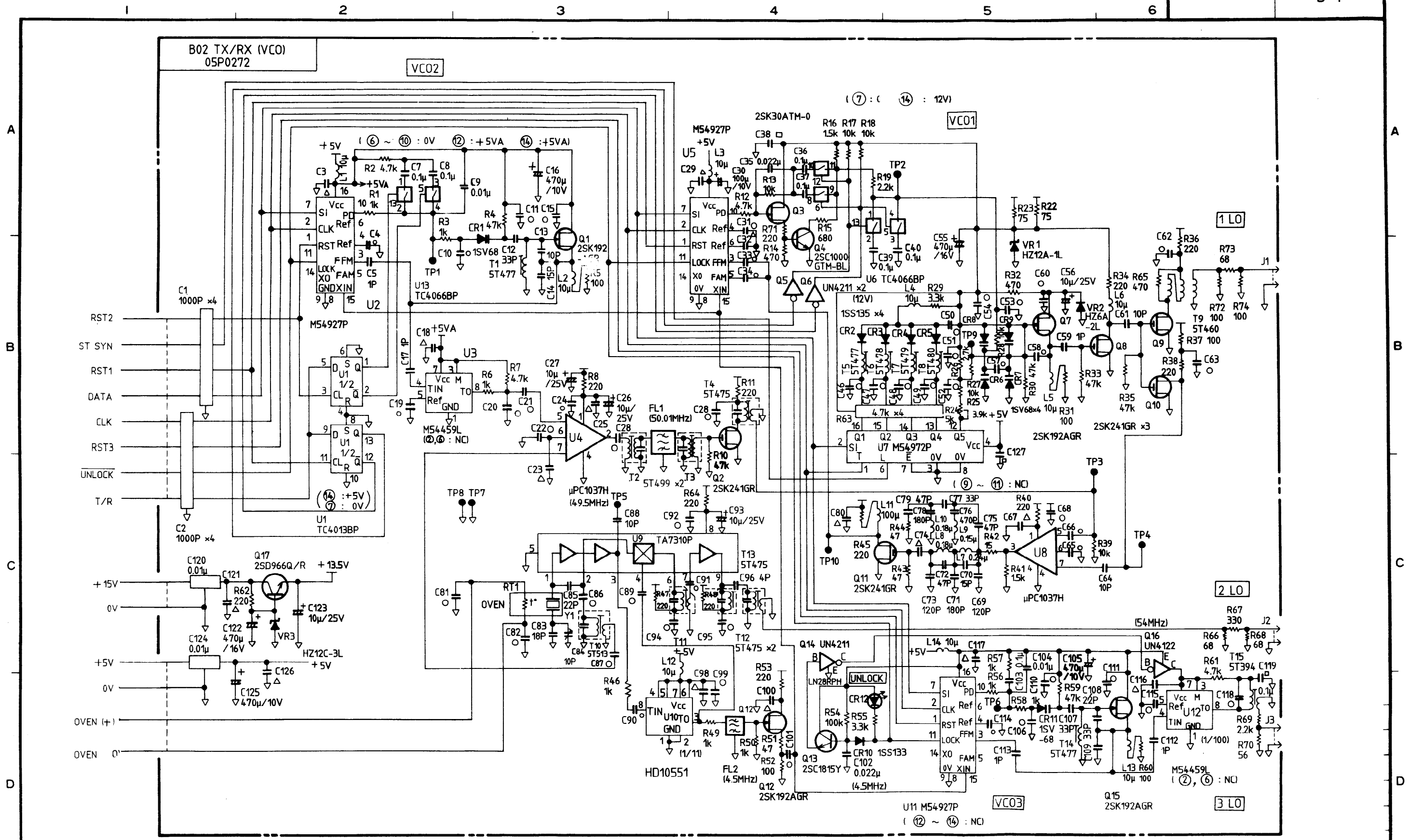

NOTE : (1) RESISTORS ARE IN Ω(1/6W), CAPACITORS ARE IN F.
 INDUCTORS ARE IN H, UNLESS OTHERWISE NOTED.
 (2) MARKS ○ ARE 1000PF/50WV CAPACITORS.
 △ ARE 0.01μF/50WV CAPACITORS AND
 □ ARE 0.1μF/25WV CAPACITORS.

承認 APPROVED	44Y.31.88 M. TABUCHI	名称 TITLE	
検 CHECKED	May. 27. '80 M. IKEDA	B02	05P0272 TX/RX (VCO)
製 DRAWN	May. 27. '88 S. N. G.	図番 DWG. NO.	E5485-015-C

FS-1500 SERIES

FURUNO ELECTRIC CO., LTD.

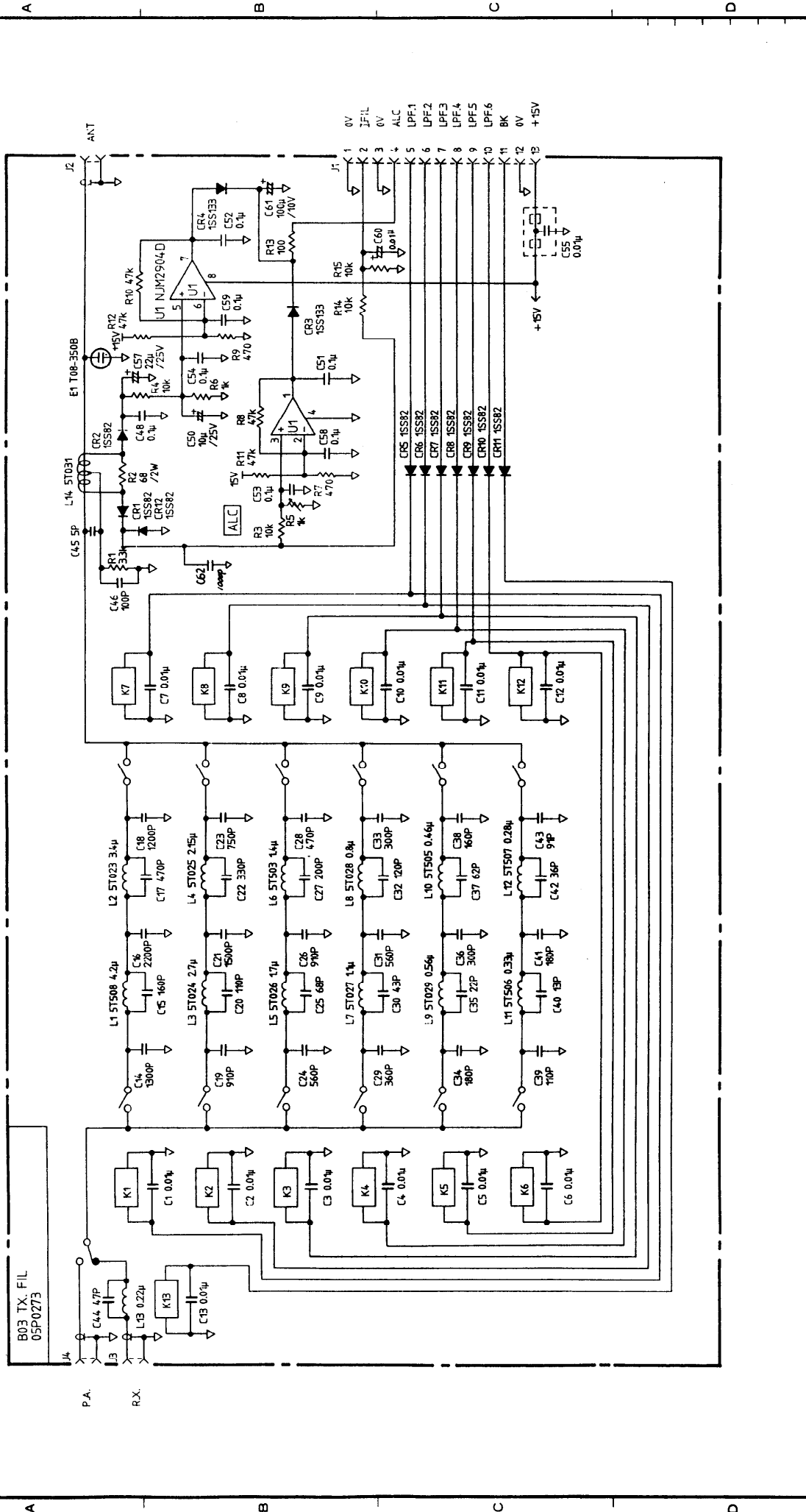

承認 APPROVED	名 称 TITLE	B03	05P0273 TX.FIL
検 査 CHECKED	製 図 DRAWN	製 図 DWG. NO.	E5485-016-D

FS-1500 SERIES

FURUNO ELECTRIC CO., LTD.

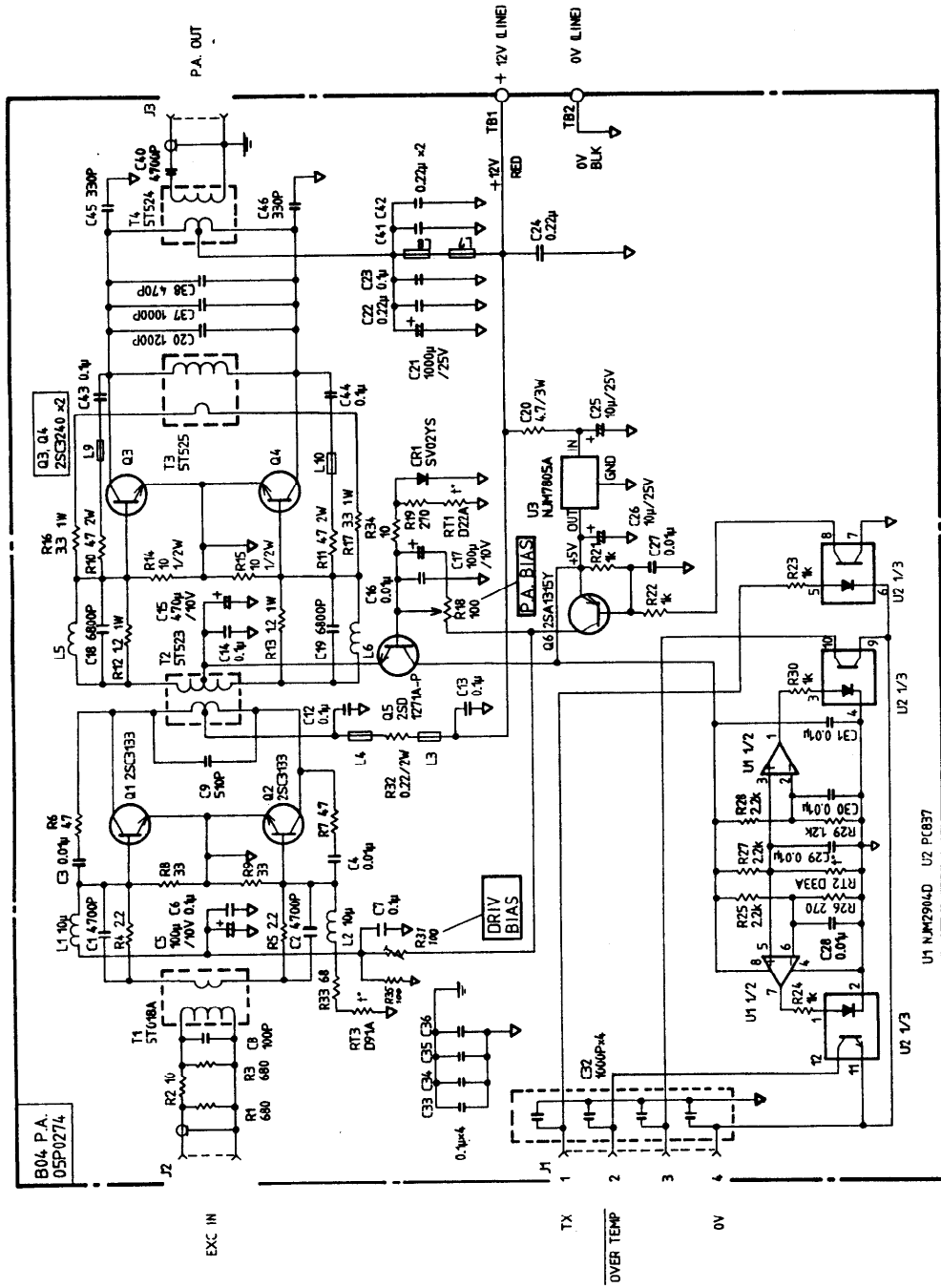

承認 MAY 31 '88	名称 TITLE	B04 05P0274 P.A.
検閲 MAY 27 '88	検閲 M.I.F.C.P.A.	
製図 MAY 27 '88	製図 S.K.S.H.L.	E5485-017-D
DRAWN	DWG. NO.	

FS-1500 SERIES

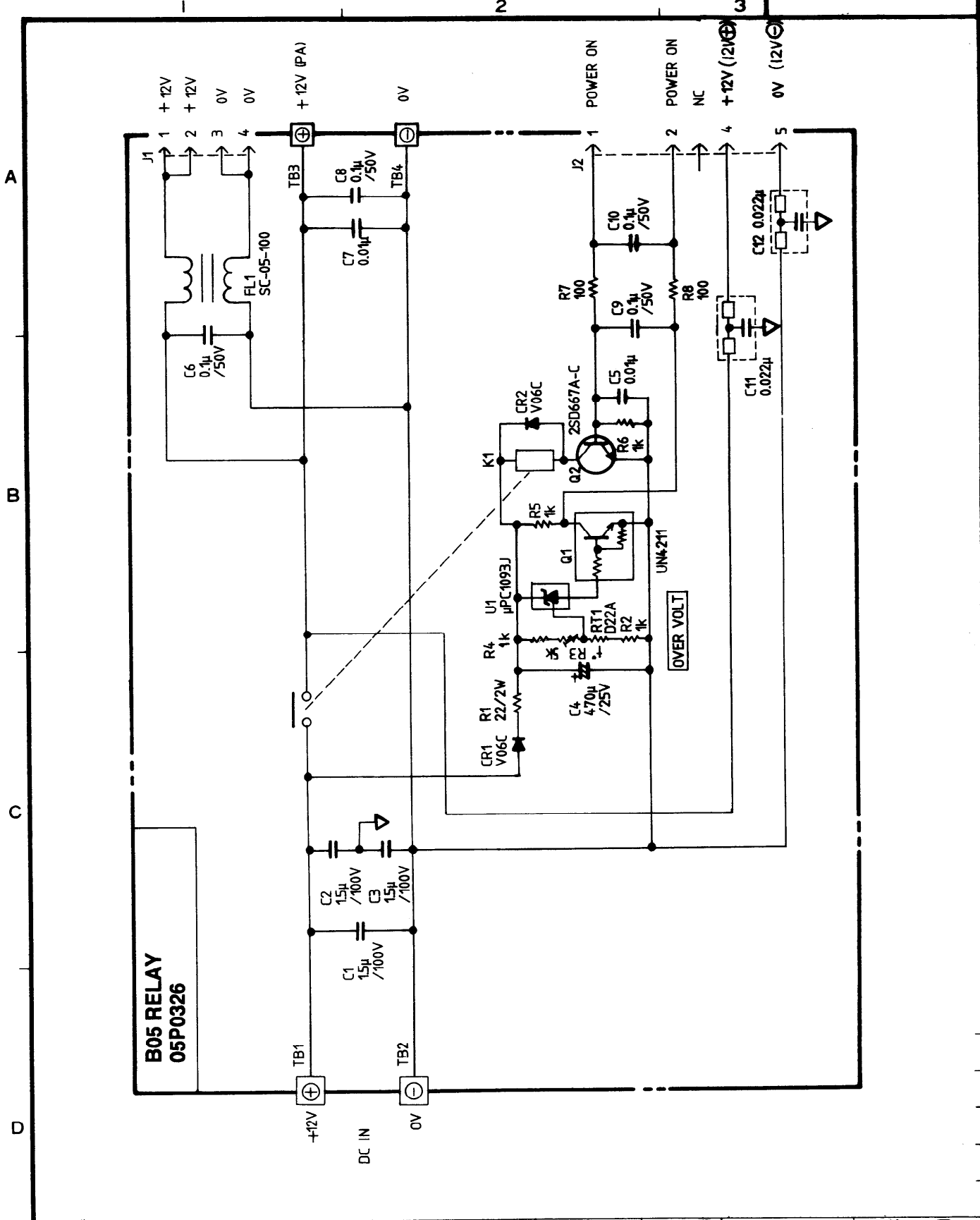

FS-1500 SERIES		品番 ITEM	品名 NAME	材質 MATERIAL	數量 Q'TY	図番 DWG. NO.	摘要 REMARKS
承認 APPROVED	MAY 31 88		三角法 THIRD ANGLE PROJECTION	名稱 TITLE			
檢圖 CHECKED	MAY 27 88		尺度 SCALE	B05 05P0326 RELAY			
製圖 DRAWN	MAY 27 88		重量 WEIGHT	kg	圖番 DWG. NO. E5485-018-D		

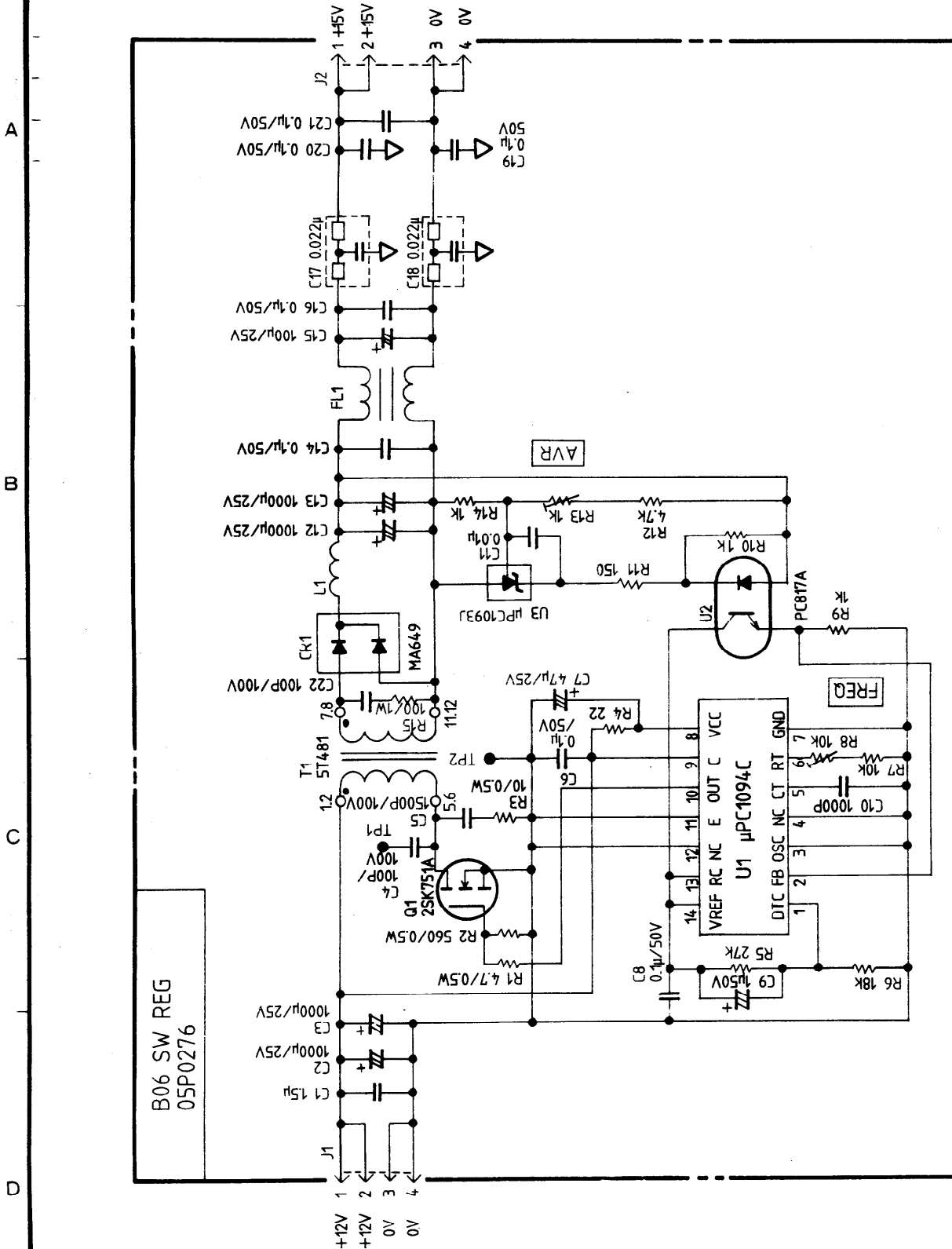

FS-1500 SERIES

品番 ITEM	品名 NAME	材質 MATERIAL	数量 Q'TY	図番 DWG.NO.	摘要 REMARKS
------------	------------	----------------	------------	---------------	---------------

承認 APPROVED	MA(31.88 M.TABUCHI)	三角法 THIRD ANGLE PROJECTION	名称 TITLE		
検 CHECKED	Map 27.88 M. IKEDA	尺 SCALE	B06 05P0276 SW. REG		
製 DRAWN	Map 27.88 M. IKEDA	重 WEIGHT	kg	図番 DWG.NO.	E5485-019-B

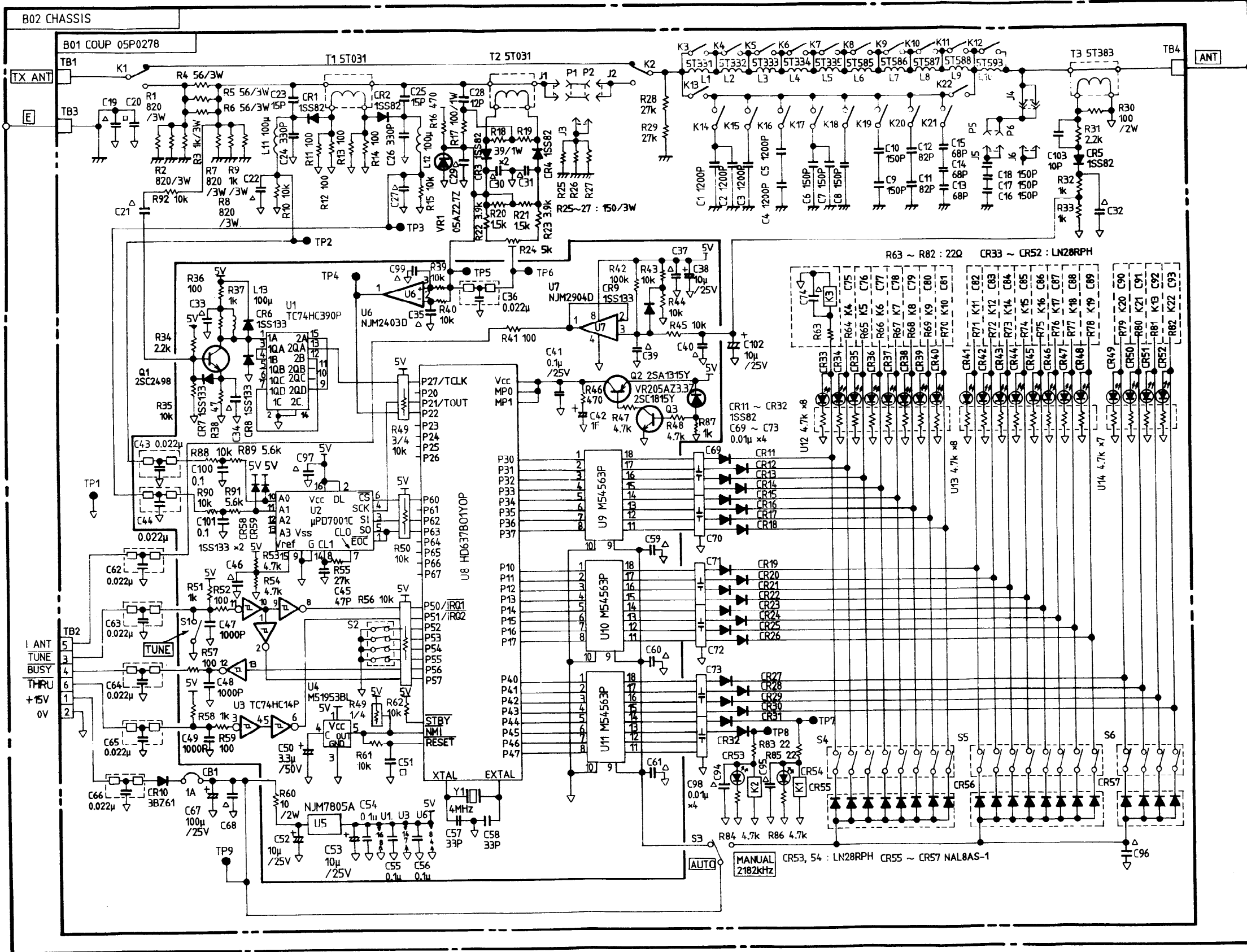

承認 APPROVED	MAY 31 1988 M. TABUCHI	名称 TITLE	AT-1500 ANTENNA COUPLER
検図 CHECKED	MAY 27 1988 M. HIGASHI	製番 DWG. NO.	E5485-020-C
製図 DRAWN	MAY 25 1988 M. HIGASHI		

FS-1500 SERIES

FURUNO ELECTRIC CO., LTD.

SPECIFICATION OF CONTROL CABLE

		2 Pairs	2 Cores
A. Conductor	Nominal Sect. Area (mm)	0.18	0.5
	Construction	7/0.18	20/0.18
	Outer Dia. (mm)	0.54	1.0
B. Insulator	Thickness (mm)	0.25	0.5
	Outer Dia (mm)	1.05	2.0
	Material	PVC	PVC
	Color	See color table below.	
C. Twist	Direction	CCW (pair)	-
	Pitch	25	60
	Outer Dia (mm)	2.1	4.85
D. Shield	Construction	Aluminum laminated tape plus drain wire (7/0.18)	
E. Sheath	Thickness	0.7	
	Finish Dia (mm)	6.5	
	Material	PVC	
	Color	White-gray	

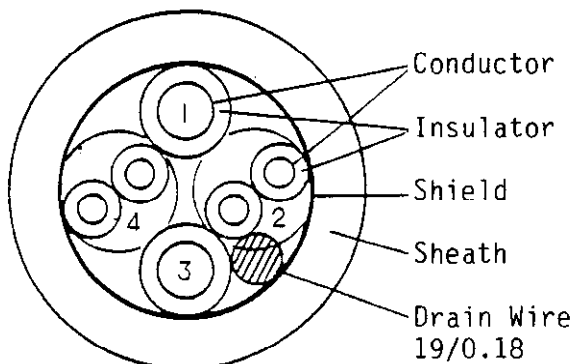

No.	Color		Size
1	RED		0.5
2	ORG	YEL	0.18
3	BLK		0.5
4	GRN	BLU	0.18

USER CHANNEL LIST (MEMORY CHANNEL LIST)

(Frequency in kHz)

GROUP No. (for SCAN)	CH No.	MEMORY A T/R for SIMP RX for DUP	MEMORY B T/R for SIMP TX for DUP	S	PURPOSE / REMARKS
1	1	.	.		
	2	.	.		
	3	.	.		
	4	.	.		
	5	.	.		
	6	.	.		
	7	.	.		
	8	.	.		
2	9	.	.		
	10	.	.		
	11	.	.		
	12	.	.		
	13	.	.		
	14	.	.		
	15	.	.		
	16	.	.		
3	17	.	.		
	18	.	.		
	19	.	.		
	20	.	.		
	21	.	.		
	22	.	.		
	23	.	.		
	24	.	.		
4	25	.	.		
	26	.	.		
	27	.	.		
	28	.	.		
	29	.	.		
	30	.	.		
	31	.	.		
	32	.	.		

S : This column is for denoting when the channel is used for Simplex.

USER CHANNEL LIST (MEMORY CHANNEL LIST)

(Frequency in kHz)

GROUP No. (for SCAN)	CH No.	MEMORY A T/R for SIMP RX for DUP	MEMORY B T/R for SIMP TX for DUP	S	PURPOSE / REMARKS
5	33	.	.		
	34	.	.		
	35	.	.		
	36	.	.		
	37	.	.		
	38	.	.		
	39	.	.		
	40	.	.		
6	41	.	.		
	42	.	.		
	43	.	.		
	44	.	.		
	45	.	.		
	46	.	.		
	47	.	.		
	48	.	.		
7	49	.	.		
	50	.	.		
	51	.	.		
	52	.	.		
	53	.	.		
	54	.	.		
	55	.	.		
	56	.	.		
8	57	.	.		
	58	.	.		
	59	.	.		
	60	.	.		
	61	.	.		
	62	.	.		
	63	.	.		
	64	.	.		

S : This column is for denoting when the channel is used for Simplex.

CONNECTION OF TELEX TERMINAL

1. GENERAL

When automatic telex communication is required, it is recommended to use Furuno Model DP-5 NBDP Terminal or Thrane-Thrane Model 1600 system comprising Radiotelex Modem TT-1585, Keyboardprocessor TT-1601A, Video Monitor TT-1602A. The maximum communication distance on the ARQ mode is about 7500km.

2. Modification of FS-1500 series Transceiver Unit

Prepare the "Telex Connection Kit(Code No.005-923-670)" for modification.

Table 1. Contents of Telex Connection Kit

No.	NAME	TYPE	CODE No.	Q'ty	REMARKS
1	5-pin Jack	FM214-5SM	000-113-464	1	
2	5-pin Plug Assy.	05S4487-0	000-113-471	1	
3	7-pin Jack	FM214-7SM	000-113-463	1	
4	7-pin Plug Assy.	05S4488-0	000-113-472	1	
5	Connector Cover	05S4426-0	000-113-346	2	
6	7-pin Plug	FM14-7P	000-113-345	1	
7	5-pin Plug	FM14-5P	000-111-537	1	
8	IC	LT1080CN	000-111-479	1	
9	Gasket	05-029-0122-2	100-087-842	2	

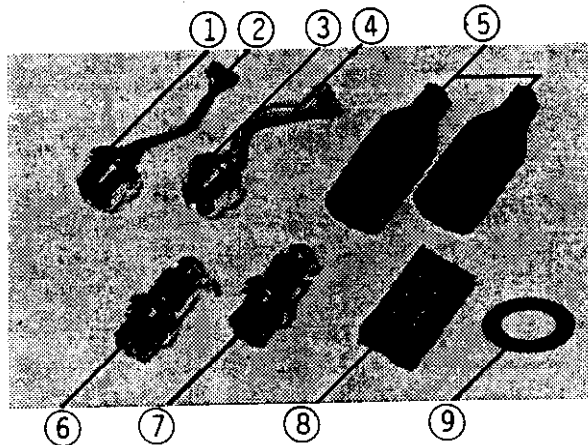

Fig 1. Telex Connection Kit

Installing the connector jacks

- 1) Peel off the seal on the back side of the transceiver.
- 2) Solder 5-pin Plug Assy. (2) to 5-pin Jack (1) and solder 7-pin Plug Assy. (4) to 7-pin Jack (3). Refer to page APC-2 or APC-3.
- 3) Fix 5-pin and 7-pin connector jacks to the chassis.
- 4) Connect the connector of the lead wire to the respective connector on the printed circuit board.

Replacement of MPU on the CPU Board

When FS-1500 series transceiver unit having S/No.5586-2840 and before(May.1991) is connected to DP-5, replacement of MPU(U1 on the CPU board) with a new one having program No.0550120110(Code No.005-937-200) is required.

3. Connection with Furuno NBDP Terminal DP-5

Connection

CONNECTOR	No.	COLOR	SIGNAL	FUNCTION
TELEX (1B08J0002)	1.	BRN	OV	Connected to ground.
	2.	RED	SCAN STOP	Not used.
	3.	ORG	TLX BK	Gets the transceiver ready to transmit.
	4.	YEL	LINE OUT(+)	0dBm/600 ohms audio output.
	5.	GRN	LINE OUT(-)	
	6.	BLU	LINE IN (+)	0dBm/600 ohms audio input.
	7.	PPL	LINE IN (-)	
REMOTE (1B08J0003)	1.	BRN	TXD	Transmit Data
	2.	RED	RTS	Request to Send
	3.	ORG	RXD	Receive Data (Cont. Sig.)
	4.	YEL	CTS	Clear to Send
	5.	GRN	OV	Common

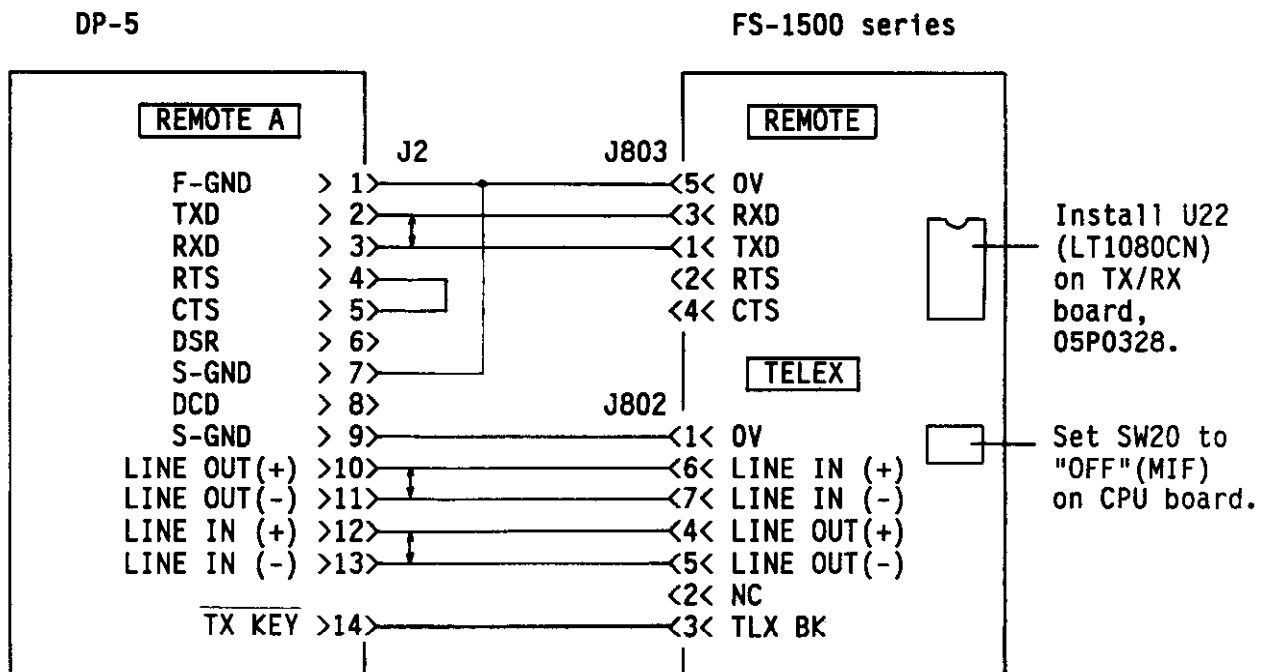

Setting of Communication Parameter on DP-5

BK Timing PreTone = 50ms
 BK Timing PostTone = 10ms
 Slave Delay = 50ms

4. Connection with T&T Model 1600

Connection

CONNECTOR	No.	COLOR	SIGNAL	FUNCTION
TELEX (1B08J0002)	1.	BRN	OV	Connected to ground.
	2.	RED	SCAN STOP	Not used.
	3.	ORG	TLX BK	Gets the transceiver ready to transmit.
	4.	YEL	LINE OUT(+)	0dBm/600 ohms audio output.
	5.	GRN	LINE OUT(-)	
	6.	BLU	LINE IN (+)	
	7.	PPL	LINE IN (-)	0dBm/600 ohms audio input.
REMOTE (1B08J0003)	1.	BRN	TXD	Transmit Data (Not used)
	2.	RED	RTS	Request to Send (Not used)
	3.	ORG	RXD	Receive Data (Cont. Sig.)
	4.	YEL	CTS	Clear to Send (Not used)
	5.	GRN	OV	Common

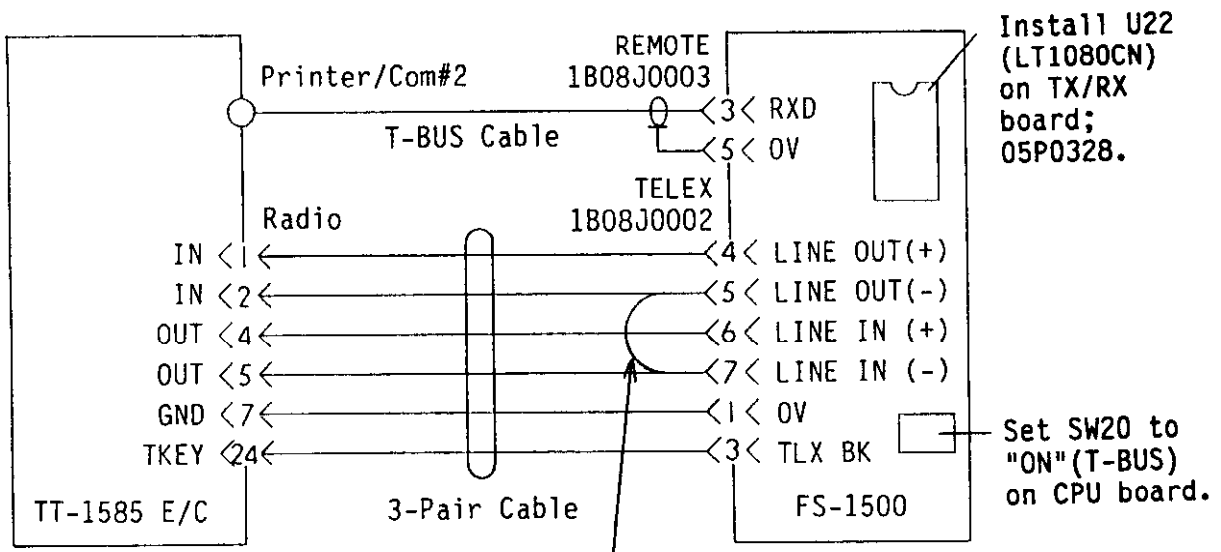

Connect a jumper wire here.
(This jumper wire is not needed for
Serial No. 5586-0426 and after.)

Setting of Communication Parameter on TT-1600

Transmitter Pre-Key = $45 \times 1.25\text{ms}$
 Transmitter Post-Key = $5 \times 1.25\text{ms}$
 Slave Delay = $45 \times 1.25\text{ms}$

5. Modification for CW operation

To operate in CW, connect telegraph key to "CW" jack on the rear side of the FS-1500 after detaching the rubber cover on the connector jack. If the plug of telegraph key dose not mate the jack, connect plug supplied as installation material, to the telegraph key.

DISTRESS CALLING PROCEDURE

Introductions : Fill in the blanks and post near your radiotelephone.

1. Turn on the power switch and press [2182] key.
2. Press [ALM] and [SEND] together.
3. Wait for about 45 sec. until transmission of two-tone alarm signal ceases.
4. Press PTT switch and send the distress message.

Speak SLOWLY CLEARLY CALMLY

- a) Say: "MAYDAY--MAYDAY--MAYDAY"
- b) Say: "This is _____, _____, _____,
your boat's name your boat's name your boat's name
_____,"
your call letter
- c) Say: "MAYDAY _____,"
your boat's name
- d) TELL WHERE YOU ARE (What navigational aids or land marks are near?)
- e) STATE THE NATURE OF YOUR DISTRESS.
- f) GIVE NUMBER OF ADULTS AND CHILDREN ABOARD, AND CONDITIONS OF ANY INJURED.
- g) ESTIMATE PRESENT SEAWORTHINESS OF YOUR BOAT.
- h) BRIEFLY DESCRIBE YOUR BOAT:

_____ ; _____ FEET; _____ FEET;
State Registration No. Length Draft

_____ ; _____ HULL; _____ TRIM; _____ MASTS; _____ POWER
Type Color Color Number Horse Power

Construction Material

Anything else you think will help rescuers to find you.

- i) Say: "I WILL BE LISTENING ON 2182kHz"
- j) End message by saying: "THIS IS _____ .OVER"
Your boat name and call sign
- k) Release PTT switch and listen: Someone should answer.
Follow his directions afterwards.
IF THEY DO NOT, REPEAT CALL, BEGINNING AT ITEM 4.

NOTES FOR FLASH MOUNT INSTALLATION OF FS-1501

1. Select a place where the LCD can be easily viewed, keeping in mind that the LCD viewing angle is as illustrated. Where required the unit may be tilted a maximum of 8°.
2. Ensure the mounting location is strong enough to support the weight of the unit (6kg approx.). If necessary fix the unit to a suitable reinforcement plate.
3. Right and left mounting brackets are supplied for flush mounting. Be careful not to interchange them when mounting.
4. Screws for bulkhead mounting (M4 bolts and nuts or $\phi 4$ screws : 8 pieces) and a reinforcement plate (where required) must be supplied locally.

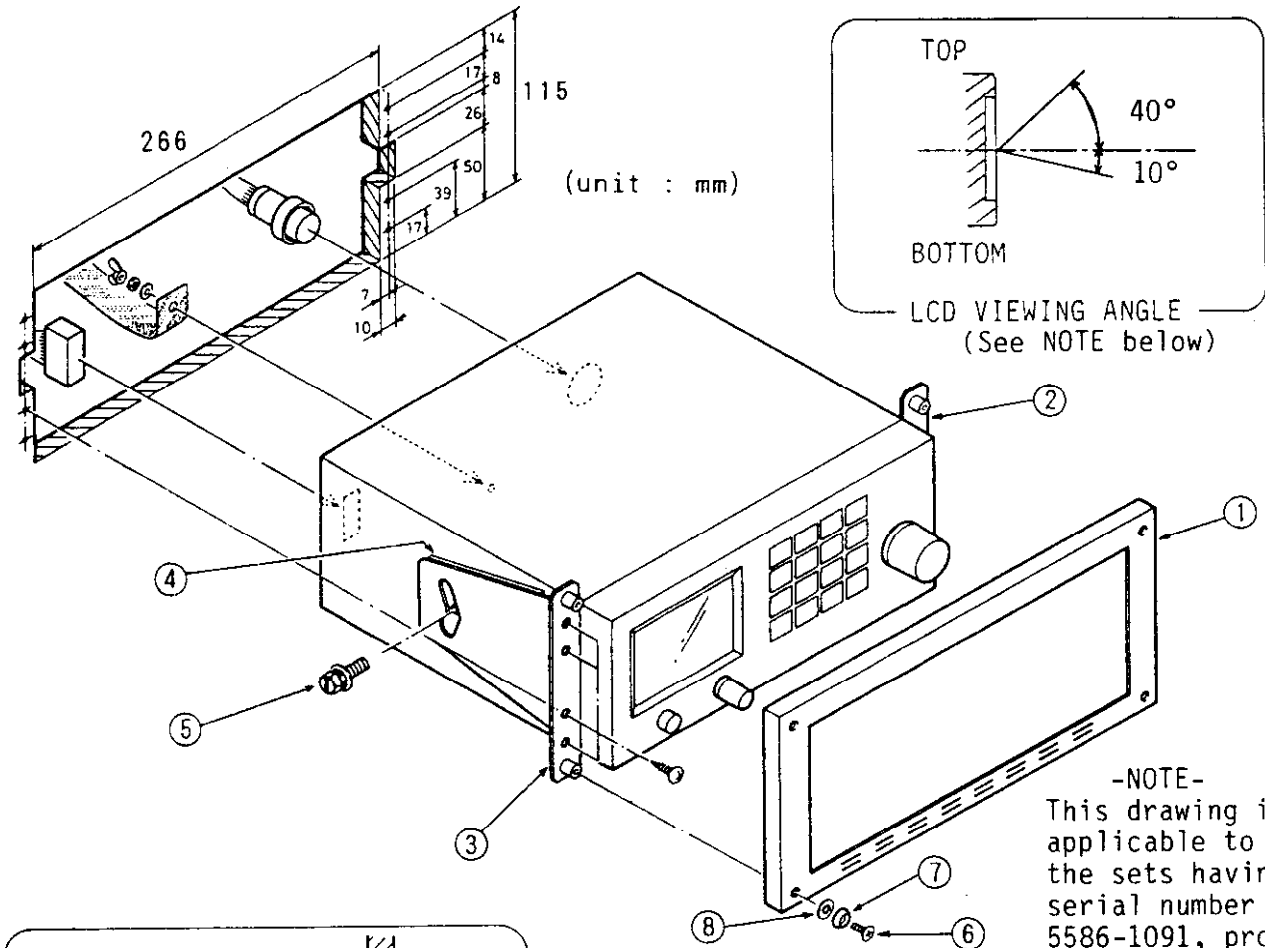

-NOTE-
This drawing is applicable to the sets having serial number 5586-1091, produced in April 1989, and after.

Parts supplied

No.	NAME	TYPE	CODE No.	QUANTITY
1	FLUSH MOUNT PANEL		100-105-470	1
2	RIGHT MOUNTING BRACKET		100-105-480	1
3	LEFT MOUNTING BRACKET		100-105-490	1
4	FLUSH MOUNT LINER		100-105-500	2
5	HEX. WASHERHEAD SCREW	M8X16	000-882-160	2
6	PANHEAD SCREW	M3X8	000-861-495	4
7	ROSETTE WASHER	M3	000-864-900	4
8	NYLON WASHER	2.8X7X0.5	000-800-728	4

Free Manuals Download Website

<http://myh66.com>

<http://usermanuals.us>

<http://www.somanuals.com>

<http://www.4manuals.cc>

<http://www.manual-lib.com>

<http://www.404manual.com>

<http://www.luxmanual.com>

<http://aubethermostatmanual.com>

Golf course search by state

<http://golfingnear.com>

Email search by domain

<http://emailbydomain.com>

Auto manuals search

<http://auto.somanuals.com>

TV manuals search

<http://tv.somanuals.com>