

FUSION®

USER MANUAL D-CLASS AMPLIFIER

CA-DA12250 CA-DA41400 CA-DA51600

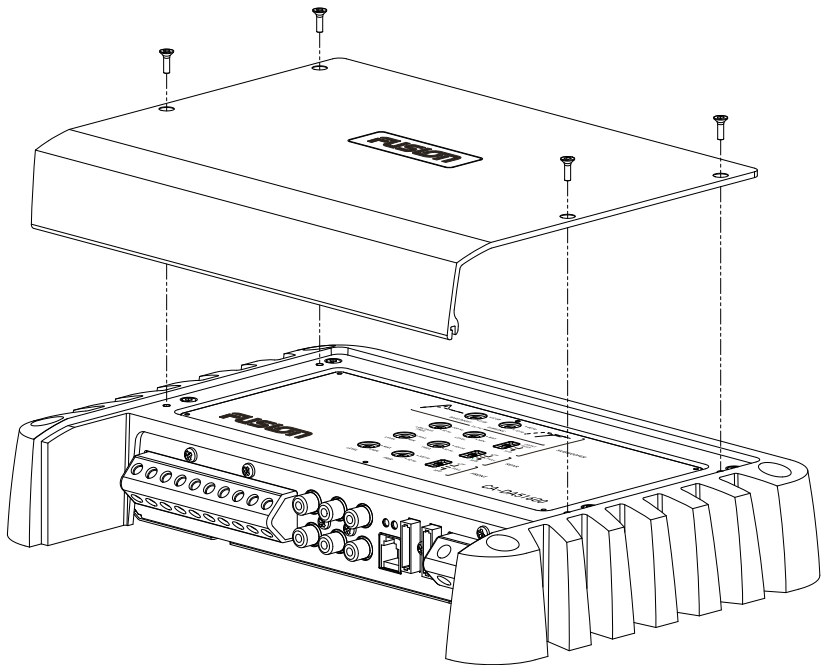

Specifications and design are subject to change without notice

AMPLIFIER SPECIFICATIONS

	CA-DA12250	CA-DA41400	CA-DA51600
Peak Power (Watts)	2250	1400	1600
Frequency Response	10Hz - 250Hz	10Hz - 65kHz	10Hz - 50kHz
Dimensions (mm)	300(l) x 210(w) x 50(h) 11-13/16 x 8-1/4 x 2"	300(l) x 210(w) x 50(h) 11-13/16 x 8-1/4 x 2"	300(l) x 210(w) x 50(h) 11-13/16 x 8-1/4 x 2"
Power Ratings	500W RMS x 1 @ 4Ω 1% THD+N	150W RMS x 4 @ 4Ω 1% THD+N	80W RMS x 4 + 250W RMS x 1 @ 4Ω 1% THD+N
	850W RMS x 1 @ 2Ω 1% THD+N	220W RMS x 4 @ 2Ω 1% THD+N	130W RMS x 4 + 330W RMS x 1 @ 2Ω 1% THD+N
	1100W RMS x 1 @ 1Ω 1% THD+N	440W RMS x 2 @ 4Ω Bridged 1% THD+N	250W RMS x 2 @ 4Ω Bridged 1% THD+N + 250W RMS x 1 @ 4Ω 1% THD+N

INSTALLATION GUIDELINES

1. Ensure the +12V lead is disconnected from the battery before you connect any new equipment.
2. Ensure the mounting location will not interfere with the gas tank, brake lines or electrical wiring.
3. Ensure the Amplifier is securely fastened to the vehicle to prevent injury in the event of an accident.
4. Ensure all wiring is protected to avoid pinching or crushing which could result in damage to the audio system.
5. Ensure the mounting location has sufficient air flow around the amplifier. If the amplifier is mounted in an enclosed space a 3" fan with ducting should be used to aid in air flow.
6. Do not mount any amplifier on a subwoofer enclosure as extended exposure to vibration may cause malfunction of the amplifier.
7. Ensure you use the recommended gauge wire/cable for all amplifier connections.

POWER

FUSION amplifiers should be connected directly to the +12V battery terminal with an inline fuse or circuit breaker as close to the battery as possible.

GROUND

When grounding/earthing your amplifier ensure that the location is a good source of ground (preferably the floor pan). Make sure the metal is clean of paint etc as a poor earth could damage your audio system.

REMOTE TURN ON

This connection turns the amplifier on & should be connected to the remote turn on wire from the Head Unit. If one is not available a switched 12v source must be used. Either a power antenna wire or ACC +12V.

LOW LEVEL INPUTS

Choose the correct length RCA cable & run them to the RCA outputs of the source/head unit, avoiding running beside other looms & or power cable.

WIRING

1. Ensure the audio system is turned off before making any connections to the amplifier, speakers or source unit, failure to do so could result in permanent damage to the audio system.
2. When wiring the FUSION amplifier ensure that the cable is protected from sharp objects and always use rubber grommets when wiring through metal panels.
3. Ensure all terminals and connections are protected from the vehicle chassis and from each other as failure to do so could result in permanent damage to the audio system.

For specific wiring information please refer to www.fusionelectronics.com

LEVEL CONTROL

This control is used to match the input level of the amplifier to the output level of your head unit. We recommend the following method. **NOTE:** Remove screws and the top cover of amplifier to access controls.

1. Turn the amplifier level to zero
2. Turn the volume of the head unit to $\frac{3}{4}$ and the bass and treble to zero
3. Adjust the level control until the desired maximum volume is achieved without distortion.
4. Failure to follow these steps may cause permanent damage to the audio system.

CROSSOVER TABLE

Model	Channels	Crossover Type	Crossover Frequency	Bass Boost
CA-DA51600	Front	Selectable - LPF, HPF, or FULL	LPF or HPF Tunable - 32Hz - 320Hz	
	Rear	Selectable - LPF, HPF, or FULL	LPF or HPF Tunable - 32Hz - 320Hz	
	Sub	Fixed LPF and Fixed HPF (Subsonic)	LPF Tunable - 32Hz - 320Hz HPF Tunable - 10Hz - 80Hz	Tunable - 0dB - 12dB
CA-DA41400	Front	Selectable - LPF, HPF, or FULL	LPF or HPF Tunable - 32Hz - 320Hz	
	Rear	Selectable - LPF, HPF, or FULL	LPF or HPF Tunable - 32Hz - 320Hz	Tunable - 0dB - 12dB
CA-DA12250	All	Fixed LPF and Fixed HPF (Subsonic)	LPF Tunable - 32Hz - 320Hz HPF Tunable - 10Hz - 80Hz	Tunable - 0dB - 12dB

TROUBLE SHOOTING

Problem	Possible Reason	Solution
Amplifier not switching on. Power LED not 'on'.	No +12v to power wire No power to remote wire Fuse broken Fuse on amplifier blown	Check fuses and connections to battery Check remote on connections to head unit Replace fuse with correct type and amperage Replace fuse with correct type and amperage
Amplifier not working, but Power LED is 'on'	Amplifier too hot Speaker wires shorted	Move amplifier to vented area Turn head unit down Check that there are no speaker wires shorted to another wire or to the vehicle chassis
No Sound	No RCA Signal Gain control not set up Head Unit off or low vol Amplifier Speakers	Check RCA connection to head unit Ensure you have set up the amplifier gain level control Check head unit volume level Check all power, remote on and ground connections Check speakers for wire shorts

AMPLIFIER DIMENSIONS

CA-DA12250, CA-DA41400, CA-DA51600

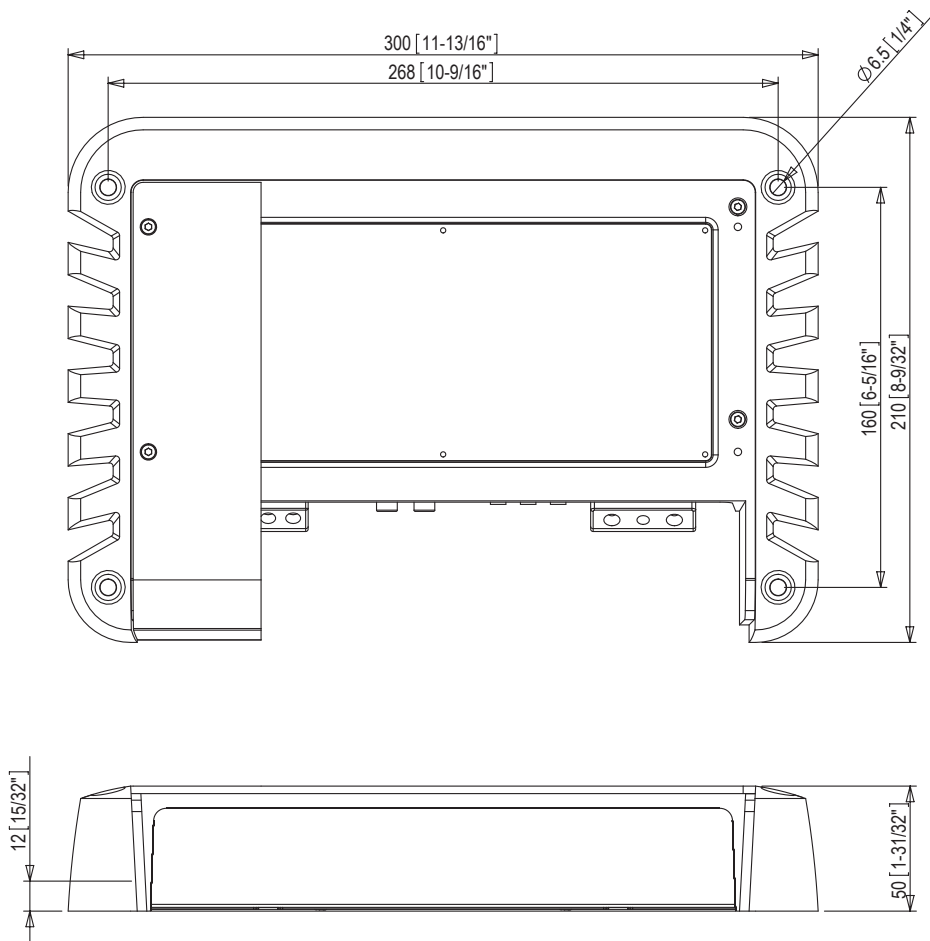

All dimensions provided are in millimeters (mm) unless indicated

Download from [Www.Somanuals.com](http://www.Somanuals.com). All Manuals Search And Download.

CA-DA12250 - CONTROL DESCRIPTIONS

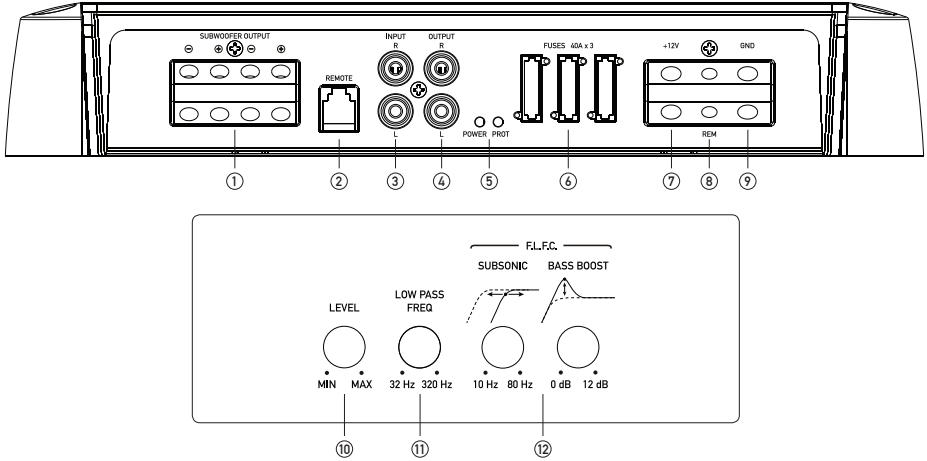

1. SPEAKER OUTPUT:

Connect your subwoofer(s) to these terminals.

NOTE: The positive (+) and negative (-) are internally linked.

2. REMOTE LEVEL CONTROL CONNECTION:

Connect the optional (supplied) Remote Level Controller to this socket.

3. RCA INPUT:

Connect these RCA connectors to a head unit with a low level output connection.

4. RCA OUTPUT:

Use these RCA connectors to connect to a secondary amplifier. This output is a pass-thru connection derived from the RCA input connectors so that the signal level and frequency response is the same as the original input signal.

5. POWER AND STATUS LED'S:

This displays "green" if the amplifier has been correctly powered up & "red" if any faults are present.

6. FUSES:

Please ensure the correct type of fuse is fitted. For CA-DA12250 3 x 40A fuses.

7. +12V CONNECTION:

Connect directly to the vehicle battery positive (+) terminal via a 4 gauge power cable, with an inline fuse or circuit breaker at the battery end. **NOTE:** This is the last wire to connect up during installation. Damage could result if this is not done.

8. REMOTE TURN-ON CONNECTION:

This terminal is for turning the amplifier on and off. The remote input requires a switched positive (+12V) to power 'ON' the amplifier. This can usually be found on the rear of the head unit in the form of a remote output. If not available you can wire to the ACC position on the ignition key.

9. GROUND CONNECTION:

Connect directly to the vehicle's chassis via a 4 gauge power cable. **NOTE:** This is the first wire to connect up during the installation.

10. LEVEL CONTROL:

This allows level adjustment of the input signal. Use this control to directly match the head unit to the amplifier. To set this control correctly, turn the amplifier level to MIN and the head unit to 3/4 volume, with the bass and treble on zero, then slowly turn up the level control towards the MAX end of the control. **NOTE:** If the sound becomes distorted, turn this control down.

11. SUBWOOFER LP FILTER FREQUENCY:

This sets the crossover frequency point for the subwoofer channels' low pass filter between 32Hz and 320Hz.

12. FUSION LOW FREQUENCY CONTROL:

The FUSION Low Frequency Control (F.L.F.C.) is a dual stage control interface. The combination of a Subsonic filter and a Bass Boost control allows precise shaping of the audio signal for your subwoofer(s). The Subsonic filter is essentially a high-pass crossover which blocks the frequency signal from 10Hz - 80Hz. This signal often contains no music and its removal will improve subwoofer control. The Bass Boost is a variable control to increase the level at 45Hz from 0 - +12dB of gain. Adjust these controls with extreme care.

CA-DA41400 - CONTROL DESCRIPTIONS

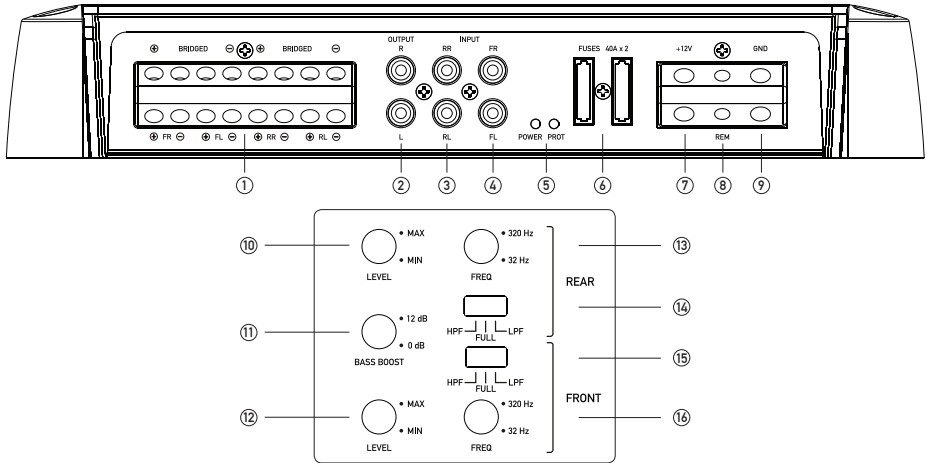

1. SPEAKER OUTPUT:

Connect your speakers to these terminals.

2. RCA OUTPUT:

Use these RCA connectors to connect to a secondary amplifier. This output is a pass-thru connection derived from the RCA input connectors so that the signal level and frequency response is the same as the original input signal.

3. REAR RCA INPUT:

Connect these RCA connectors to a head unit with a rear low level output connection.

4. FRONT RCA INPUT:

Connect these RCA connectors to a head unit with a front low level output connection.

5. POWER AND STATUS LED'S:

This displays "green" if the amplifier has been correctly powered up & "red" if any faults are present.

6. FUSES:

Please ensure the correct type of fuse is fitted. For CA-DA41400 2 x 40A fuses.

7. +12V CONNECTION:

Connect directly to the vehicle battery positive (+) terminal via a 4 gauge power cable, with an inline fuse or circuit breaker at the battery end. **NOTE:** This is the last wire to connect up during installation. Damage could result if this is not done.

8. REMOTE TURN-ON CONNECTION:

This terminal is for turning the amplifier on and off. The remote input requires a switched positive (+12V) to power 'ON' the amplifier. This can usually be found on the rear of the head unit in the form of a remote output. If not available you can wire to the ACC position on the ignition key.

9. GROUND CONNECTION:

Connect directly to the vehicle's chassis via a 4 gauge power cable. **NOTE:** This is the first wire to connect up during the installation.

10. REAR LEVEL:

This allows level adjustment of the front input signal. Use this control to directly match the head unit to the amplifier. To set this control correctly, turn the amplifier level to MIN and the head unit to 3/4 volume, with the bass and treble on zero, then slowly turn up the level control towards the MAX end of the control. **NOTE:** If the sound becomes distorted, turn this control down.

11. BASS BOOST:

The Bass Boost is a variable control to increase the level at 45Hz from 0 - +12dB of gain. Adjust this control with extreme care.

12. FRONT LEVEL:

This allows level adjustment of the rear input signal. Use this control to directly match the head unit to the amplifier. To set this control correctly, turn the amplifier level to MIN and the head unit to 3/4 volume, with the bass and treble on zero, then slowly turn up the level control towards the MAX end of the control. **NOTE:** If the sound becomes distorted, turn this control down.

13. REAR FILTER FREQUENCY:

This sets the crossover frequency point for the rear filter between 32Hz and 320Hz. **NOTE:** Failure to correctly set could result in speaker damage.

14. REAR FILTER SELECTION:

This switch selects the type of filter used for the rear audio signal. Either Low Pass, High Pass or Full Range can be selected. The Low Pass filter is designed to filter out all mid to high frequencies that only full range speakers should produce. The High Pass filter is designed to filter out all low frequencies that only subwoofers should produce. Full Range allows all frequencies.

15. FRONT FILTER SELECTION:

This switch selects the type of filter used for the front audio signal. Either Low Pass, High Pass or Full Range can be selected. The Low Pass filter is designed to filter out all mid to high frequencies that only full range speakers should produce. The High Pass filter is designed to filter out all low frequencies that only subwoofers should produce. Full Range allows all frequencies.

16. FRONT FILTER FREQUENCY:

This sets the crossover frequency point for the front filter between 32Hz and 320Hz. **NOTE:** Failure to correctly set could result in speaker damage.

CA-DA51600 - CONTROL DESCRIPTIONS

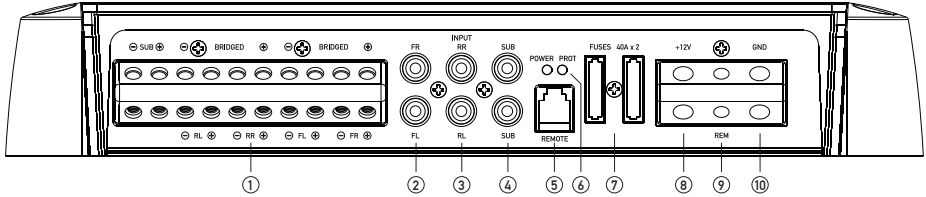

1. SPEAKER OUTPUT:

Connect your speakers to these terminals.

2. FRONT RCA INPUT:

Connect these RCA connectors to a head unit with a front low level output connection.

3. REAR RCA INPUT:

Connect these RCA connectors to a head unit with a rear low level output connection.

4. SUBWOOFER RCA INPUT:

Connect these RCA connectors to a head unit with a subwoofer low level output connection.

5. REMOTE LEVEL CONTROL CONNECTION:

Connect the optional (supplied) Remote Level Controller to this socket.

6. POWER AND STATUS LED'S:

This displays "green" if the amplifier has been correctly powered up and "red" if any faults are present.

7. FUSES:

Please ensure the correct type of fuse is fitted. For CA-DA51600 2 x 40A fuses.

8. +12V CONNECTION:

Connect directly to the vehicle battery positive (+) terminal via a 4 gauge power cable, with an inline fuse or circuit breaker at the battery end. **NOTE:** This is the last wire to connect up during installation. Damage could result if this is not done.

9. REMOTE TURN-ON CONNECTION:

This terminal is for turning the amplifier on & off. The remote input requires a switched positive (+12V) to power "ON" the amplifier. This can usually be found on the rear of the head unit in the form of a remote output. If not available you can wire to the ACC position on the ignition key.

10. GROUND CONNECTION:

Connect directly to the vehicle's chassis via a 4 gauge power cable. **NOTE:** This is the first wire to connect up during the installation.

11. SUBWOOFER LP FILTER FREQUENCY:

This sets the crossover frequency point for the subwoofer channels' low pass filter between 32Hz and 320Hz.

12. REAR LEVEL:

This allows level adjustment of the rear input signal. Use this control to directly match the head unit to the amplifier. To set this control correctly, turn the amplifier level to MIN and the head unit to 3/4 volume, with the bass and treble on zero, then slowly turn up the level control towards the MAX end of the control. **NOTE:** If the sound becomes distorted, turn this control down.

13. FRONT LEVEL:

This allows level adjustment of the front input signal. Use this control to directly match the head unit to the amplifier. To set this control correctly, turn the amplifier level to MIN and the head unit to 3/4 volume, with the bass and treble on zero, then slowly turn up the level control towards the MAX end of the control. **NOTE:** If the sound becomes distorted, turn this control down.

14. FUSION LOW FREQUENCY CONTROL:

The FUSION Low Frequency Control (F.L.F.C.) is a dual stage control interface. The combination of a Subsonic filter & a

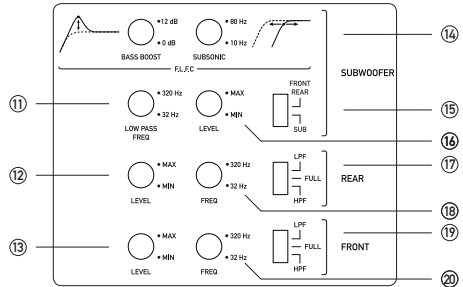

Bass Boost control allows precise shaping of the audio signal for your subwoofer(s). The Subsonic filter is essentially a high-pass crossover which blocks the frequency signal from 10Hz - 80Hz. This signal often contains no music & its removal will improve subwoofer control. The Bass Boost is a variable control to increase the level at 45Hz from 0 - +12dB of gain. Adjust these controls with extreme care.

15. SUBWOOFER AUDIO SOURCE:

This switch selects the audio source for the subwoofer channel. Audio can be sourced from the SUB input RCA connectors or from the FRONT & REAR input RCA connectors.

16. SUBWOOFER LEVEL:

This allows level adjustment of the subwoofer input signal. Use this control to directly match the head unit to the amplifier. To set this control correctly, turn the amplifier level to MIN & the head unit to 3/4 volume, with the bass and treble on zero, then slowly turn up the level control towards the MAX end of the control. **NOTE:** If the sound becomes distorted, turn this control down.

17. REAR FILTER FREQUENCY:

This sets the crossover frequency point for the rear filter between 32Hz and 320Hz. **NOTE:** Failure to correctly set could result in speaker damage.

18. REAR FILTER SELECTION:

This switch selects the type of filter used for the rear audio signal. Either Low Pass, High Pass or Full Range can be selected. The Low Pass filter is designed to filter out all mid to high frequencies that only full range speakers should produce. The High Pass filter is designed to filter out all low frequencies that only subwoofers should produce. Full Range allows all frequencies.

19. FRONT FILTER SELECTION:

This switch selects the type of filter used for the rear audio signal. Either Low Pass, High Pass or Full Range can be selected. The Low Pass filter is designed to filter out all mid to high frequencies that only full range speakers should produce. The High Pass filter is designed to filter out all low frequencies that only subwoofers should produce. Full Range allows all frequencies.

20. FRONT FILTER FREQUENCY:

This sets the crossover frequency point for the rear filter between 32Hz and 320Hz. **NOTE:** Failure to correctly set could result in speaker damage.

RECORD YOUR PURCHASE DETAILS HERE:

SERIAL NUMBER

DATE OF PURCHASE

AFFIX RECEIPT HERE

FUSION[®]

www.fusionelectronics.com

FUSION Electronics New Zealand

Ph: +64 9 369 2900

FUSION Electronics Australia

Ph: +61 1300 736 012

FUSION Electronics Europe

Ph: +44 845 299 7586

FUSION Electronics USA

Ph: +1 623 580 9000

For further product and installation information, please visit www.fusionelectronics.com

Pour plus d'informations sur les produits et l'installation, rendez-vous sur www.fusionelectronics.com

Para obtener más información acerca de los productos y de su instalación, visite el sitio web www.fusionelectronics.com

Bezoek www.fusionelectronics.com voor meer product- en installatie-informatie.

Weitere Produkt- und Installationsinformationen finden Sie unter www.fusionelectronics.com

Per ulteriori informazioni sui prodotti e la loro installazione, potete visitare www.fusionelectronics.com

Для получения дополнительной информации о продуктах и установке зайдите, пожалуйста, на: www.fusionelectronics.com

WARNING: Audio Systems can produce sound levels over 135dB. Continuous exposure to sound pressure levels over 100dB may cause permanent hearing loss! Please watch for emergency vehicles as warning signals may not be heard. USE COMMON SENSE!



PUBLISHED BY FUSION ELECTRONICS LIMITED. © Copyright 2010 by FUSION Electronics Limited. All rights reserved. Specifications and design are subject to change without notice.
YOU CAN HELP PROTECT THE ENVIRONMENT! Please remember to respect the local regulations: Hand in the non-working electrical equipment to an appropriate waste disposal center.

Free Manuals Download Website

<http://myh66.com>

<http://usermanuals.us>

<http://www.somanuals.com>

<http://www.4manuals.cc>

<http://www.manual-lib.com>

<http://www.404manual.com>

<http://www.luxmanual.com>

<http://aubethermostatmanual.com>

Golf course search by state

<http://golfingnear.com>

Email search by domain

<http://emailbydomain.com>

Auto manuals search

<http://auto.somanuals.com>

TV manuals search

<http://tv.somanuals.com>