

Fishfinder 250/250C

*high-resolution sonar
owner's manual*



(Fishfinder 250C shown)

© Copyright 2004 Garmin Ltd. or its subsidiaries

Garmin International, Inc.

1200 East 151st Street, Olathe, KS 66062, U.S.A.

Tel. 913/397.8200 or 800/800.1020 Fax 913/397.8282

Garmin (Europe) Ltd.

Unit 5, The Quadrangle, Abbey Park Industrial Estate, Romsey SO51 9DL, U.K.

Tel. 44/1794.519944 Fax 44/1794.519222

Garmin Corporation

No. 68, Jangshu 2nd Road, Shijr, Taipei County, Taiwan

Tel. 886/2.2642.9199 Fax 886/2.2642.9099

All Rights Reserved. Except as expressly provided herein, no part of this manual may be reproduced, copied, transmitted, disseminated, downloaded or stored in any storage medium, for any purpose without prior written consent of Garmin. Garmin hereby grants permission to download a single copy of this manual and of any revision of this manual onto a hard drive or other electronic storage medium to be viewed and to print one copy of this manual or any revision hereto, provided that such electronic or printed copy of this manual or revision must contain the complete text of this copyright notice and provided further that any unauthorized commercial distribution of this manual or any revision hereto is strictly prohibited.

Information in this manual is subject to change without notice. Garmin reserves the right to change or improve its products and to make changes in the content without obligation to notify any person or organization of such changes. Visit the Garmin web site (www.garmin.com) for current updates and supplemental information concerning the use and operation of this and other Garmin products.

GARMIN®, See-Thru® and DCG (Depth Control Gain)® are registered trademarks of Garmin Ltd. or its subsidiaries and may not be used without the express permission of Garmin.

February 2004

Part Number 190-00328-00 Rev. A

Printed in Taiwan

Preface

Thank you for choosing the Garmin Fishfinder 250/250C. This product is designed for easy operation and to provide years of reliable service.

Operations for the Fishfinder 250 and Fishfinder 250C are the same unless otherwise noted. To ensure that you get the most from the Fishfinder 250/250C, please take the time to read this Owner's Manual and learn the operation of your new unit. This manual is broken down into three sections. Section One covers the installation and testing for the Fishfinder 250/250C. Section Two provides detailed references to the features and operations of the Fishfinder 250/250C. Section Three gives a basic overview of how sonar works and provides information on interpreting the sonar graph.

Product Support

If you encounter a problem or just have a question, our Product Support Department can be reached Monday-Friday 8am to 5pm Central Time.

By phone at— 1-800-800-1020 or (913)397-8200

Online at— <http://www.garmin.com/contactUs/techSupport.jsp>

Check the Garmin Web Site (www.garmin.com) for links to Product Support and Product FAQ's

Enjoy your new Fishfinder 250/250C and once again thank you for choosing Garmin.

Product Registration

Help us better support you by completing our on-line registration today! Connect to our web site (www.garmin.com) and look for the Product Registration link on the Home page. Your unit's serial number is located on the back of the unit.



NOTE: If you have previously registered a Garmin product purchase, we invite you to re-register using our on-line system. Many services provided by our product registration system are now automated and re-registering your purchase ensures you the best possible support from Garmin.

Introduction

Warranty and Serial Number

Serial Number

Use this area to record the serial number (8-digit number located on the back of the unit) in case it is lost, stolen, or needs service. Be sure to keep your original sales receipt in a safe place or attach a photocopy inside the manual.

Serial Number:

* *



The Fishfinder 250/250C is fastened shut with screws. Any attempt to open the case to change or modify the unit in any way will void your warranty and may result in permanent damage to the equipment.

LIMITED WARRANTY

This Garmin product is warranted to be free from defects in materials or workmanship for one year from the date of purchase. Within this period, Garmin will at its sole option, repair or replace any components that fail in normal use. Such repairs or replacement will be made at no charge to the customer for parts or labor, provided that the customer shall be responsible for any transportation cost. This warranty does not cover failures due to abuse, misuse, accident or unauthorized alteration or repairs.

THE WARRANTIES AND REMEDIES CONTAINED HEREIN ARE EXCLUSIVE AND IN LIEU OF ALL OTHER WARRANTIES EXPRESS OR IMPLIED OR STATUTORY, INCLUDING ANY LIABILITY ARISING UNDER ANY WARRANTY OF MERCHANTABILITY OR FITNESS FOR A PARTICULAR PURPOSE, STATUTORY OR OTHERWISE. THIS WARRANTY GIVES YOU SPECIFIC LEGAL RIGHTS, WHICH MAY VARY FROM STATE TO STATE.

IN NO EVENT SHALL GARMIN BE LIABLE FOR ANY INCIDENTAL, SPECIAL, INDIRECT OR CONSEQUENTIAL DAMAGES, WHETHER RESULTING FROM THE USE, MISUSE, OR INABILITY TO USE THIS PRODUCT OR FROM DEFECTS IN THE PRODUCT. Some states do not allow the exclusion of incidental or consequential damages, so the above limitations may not apply to you.

Garmin retains the exclusive right to repair or replace the unit or software or offer a full refund of the purchase price at its sole discretion. SUCH REMEDY SHALL BE YOUR SOLE AND EXCLUSIVE REMEDY FOR ANY BREACH OF WARRANTY.

To obtain warranty service, contact your local Garmin authorized dealer. Or call Garmin Customer Service at one of the numbers shown below, for shipping instructions and an RMA tracking number. The unit should be securely packed with the tracking number clearly written on the outside of the package. The unit should then be sent, freight charges prepaid, to any Garmin warranty service station. A copy of the original sales receipt is required as the proof of purchase for warranty repairs.

Products sold through online auctions are not eligible for rebates or other special offers from Garmin. Online auction confirmations are not accepted for warranty verification. To obtain warranty service, an original or copy of the sales receipt from the original retailer is required. Garmin will not replace missing components from any package purchased through an online auction.

Garmin International, Inc.
1200 East 151st Street
Olathe, Kansas 66062, U.S.A.
Phone: 913/397.8200
FAX: 913/397.0836

Garmin (Europe) Ltd.
Unit 4, The Quadrangle, Abbey Park Industrial Estate
Romsey, SO51 9DL, U.K.
Phone: 44/1794.519944
FAX: 44/1794.519222

Software License Agreement

BY USING THE FISHFINDER 250/250C, YOU AGREE TO BE BOUND BY THE TERMS AND CONDITIONS OF THE FOLLOWING SOFTWARE LICENSE AGREEMENT. PLEASE READ THIS AGREEMENT CAREFULLY.

Garmin grants you a limited license to use the software embedded in this device (the “Software”) in binary executable form in the normal operation of the product. Title, ownership rights and intellectual property rights in and to the Software remain in Garmin.

You acknowledge that the Software is the property of Garmin and is protected under the United States of America copyright laws and international copyright treaties. You further acknowledge that the structure, organization and code of the Software are valuable trade secrets of Garmin and that the Software in source code form remains a valuable trade secret of Garmin. You agree not to decompile, disassemble, modify, reverse assemble, reverse engineer or reduce to human readable form the Software or any part thereof, or to create any derivative works based on the Software. You agree not to export or re-export the Software to any country in violation of the export control laws of the United States of America.



WARNING: This product, its packaging, and its components contain chemicals known to the State of California to cause cancer, birth defects, or reproductive harm. This Notice is being provided in accordance with California’s Proposition 65. If you have any questions or would like additional information, please refer to our web site at <http://www.garmin.com/prop65>.

Software License Agreement

Packing List



For the most recent list of available accessories for your unit, current user manuals and software updates, visit our web site at www.garmin.com.

Before installing and getting started with your unit, please check to see that your package includes the following items. The package part number can be found on the outside of the box. **If any parts are missing, please contact your Garmin dealer immediately.**

Fishfinder 250 Standard Package (010-00343-00 w/o transducer):

- Fishfinder 250 Unit • Swivel Mount Bracket and Knobs • Power/Data Cable • Owner's Manual
- Self-Adhesive Quick Reference Guide • Protective Cover • Flush-Mount Hardware Kit

Fishfinder 250 Optional Package (010-00343-01) includes Standard Package, plus:

- Dual Frequency (200/50kHz, 10/40°) Plastic Transom Mount Transducer with Depth and Temp

Fishfinder 250 Optional Package (010-00343-02) includes Standard Package, plus:

- Single Frequency (200kHz, 14°) Plastic Transom Mount Transducer with Depth and Temp

Fishfinder 250C Standard Package (010-00341-00 w/o transducer):

- Fishfinder 250C Unit • Swivel Mount Bracket and Knobs • Power/Data Cable • Owner's Manual
- Self-Adhesive Quick Reference Guide • Protective Cover • Flush-Mount Hardware Kit

Fishfinder 250C Optional Package (010-00341-01) includes Standard Package, plus:

- Dual Frequency (200/50kHz, 10/40°) Plastic Transom Mount Transducer with Depth and Temp
- Separate Speed Sensor

Fishfinder 250C Optional Package (010-00341-02) includes Standard Package, plus:

- Single Frequency (200kHz, 14°) Plastic Transom Mount Transducer with Depth and Temp
- Separate Speed Sensor

Optional Accessories:

- Quick-Release Flush Mount Bracket; US A/C PC Adapter; EURO A/C PC Adapter; Cigarette Lighter Adapter; 2nd Mounting Station; 10 ft. Transducer Extension cable; 20 ft. Transducer Extension cable; Temperature probe; Speed sensor; Plastic, thru-hull mount, Temp & Speed sensor only.

Transducers

The transducer acts as the eyes and ears of your sonar, transmitting sound waves toward the bottom in a cone shape. Proper transducer selection and installation are important to the operation of your unit. It is best to select a transducer that suits the depth of the water that you are on.

A wide cone angle transducer works best in shallower water, providing a large coverage or viewing area, but at a decreased bottom resolution. In deep water this can result in a large area where fish cannot be seen.

A narrow cone angle transducer is better suited to deep water installations, providing a smaller coverage or viewing area than a wide cone transducer, but with improved bottom resolution and a smaller dead zone.

Optional Transducers:

Included in the *Optional Packages* (p. iv) are transom mount transducers and separate speed sensors. These transducers provide good all-around performance. In addition, a variety of optional transducers are available from your local dealer or direct from Garmin.

- 200/50kHz, 12/45°, plastic, transom mount, depth, temp
- 200/50kHz, 12/45°, plastic, transom mount, depth, temp, speed
- 200/50kHz, 12/45°, bronze, thru-hull mount, depth
- 200/50kHz, 12/45°, bronze, thru-hull mount, depth, temp, speed
- 200/50kHz, 12/45°, bronze, thru-hull mount/long stem, depth, temp, speed
- 200/50kHz, 12/45°, plastic, thru-hull mount, depth
- 200/50kHz, 12/45°, plastic, adjustable, in-hull mount
- 200kHz, 14°, plastic, transom mount, depth
- 200kHz, 14°, plastic, transom mount, depth, temp
- 200kHz, 14°, plastic, transom mount, depth, temp, speed
- 200kHz, 8°, plastic, transom mount, depth, temp
- 200kHz, 8°, plastic, transom mount, depth, temp, speed
- 200kHz, 12°, bronze, thru-hull mount, depth
- 200kHz, 12°, bronze, thru-hull mount, depth, temp
- 200kHz, 9°, bronze, thru-hull mount, depth, temp, speed
- 200kHz, 12°, plastic, thru-hull mount, depth
- 200kHz, 12°, plastic, thru-hull mount, depth, temp
- 200kHz, 14°, plastic, in-hull mount, depth
- 200kHz, 14°, plastic, trolling motor mount, depth, temp

Download from Www.Somanuals.com. All Manuals Search And Download.

Selecting a Transducer

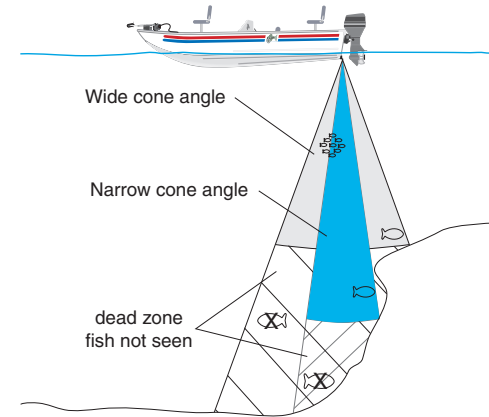

Introduction

Table of Contents

Introduction	i-vi
Preface and Registration	i
Warranty	ii
Software License Agreement	iii
Packing List	iv
Selecting a Transducer	v
Table of Contents	vi
Section One: Installation	1-9
Unit Installation	1
Wiring and Interfacing	5
Mounting the Transducer	7
Testing the Installation	9
Section Two: Unit Operation	10-22
Keypad Usage	10
Sonar Page	11
Using the Adjustment Menu	12
Adjustment Menu Options	12
Range	12
Zoom	12
View/Span	13
Gain	13
Target Level	13
Whiteline	14
Frequency	14

Depth Line	14	Simulator	20
Noise Reject	14	NMEA Input/Output	20
Scroll	14	Factory Settings	20
Size Split	14	Software Version	20
Pausing the Sonar Page	15	Reset Odometer	20
Main Menu	16	Units Tab	20
Graph Tab	16	Depth	20
Fish Symbols	16	Temperature	20
Scale	16	Distance and Speed	20
Custom Range	16	Position Format	20
Background Color	17	Heading	21
Number Size	17	Sonar Tab	21
Temperature and Water Speed	17	Water Type	21
Tools Tab	17	Depth Number	21
Flasher	17	Automatic Scroll Speed Limit	21
Color Bar	17	Keel Offset	21
Temperature Graph	17	Transducer Type	21
Advanced Data Fields	17	Calibrate Water Speed	21
Temp Tab	18	Time Tab	22
Log and Graph Scale	18	Time Format	22
Reset (Scale)	18	Time Zone	22
Log Duration	18	Daylight Saving Time	22
Alarms Tab	19	Current Time and Date	22
Fish Alarm	19	Section Three: On the Water	23-26
Shallow/Deep Water Alarms	19	Understanding Sonar	23
Drift Alarm	19	Transducer Coverage	24
Water Temperature Alarm	19	Understanding the Graph	25
Battery Alarm	19	Whiteline and Thermoclines	26
Timer Alarm	19	Appendices	27-30
System Tab	20	Appendix A: Specifications and Cleaning	27
Beeper	20	Appendix B: Messages and Alarms	28
Display Mode	20	Appendix C: Index	29
Language	20		

Installing the Fishfinder 250/250C

The Fishfinder 250/250C must be properly installed according to the following instructions to get the best possible performance. To complete the installation, you'll need the appropriate fasteners and tools. Verify that all cables can reach the unit mounting location and also take time to read through these instructions prior to installation. Be sure to always wear safety goggles and a dust mask when drilling, cutting or sanding. **When in doubt, seek professional assistance.**

Selecting a Proper Location

Choose a location that provides optimal viewing while operating the vessel and allows easy access to the unit's keypad. Select a mounting surface strong enough to support the weight of the unit and protect it from excessive vibration and shock. DO NOT mount the bracket in a location where the unit is exposed to extreme temperature conditions. When installing the mounting bracket, be sure to allow room for the connection/routing of the power and transducer cables.

Swivel Mounting the Fishfinder 250/250C Unit

The Fishfinder 250/250C's compact, waterproof case is suitable for mounting in exposed locations or at the nav station. The unit comes with a swivel-mount bracket that can be used for console or overhead mounting. When choosing a location for the display unit, make sure you consider the following conditions:

- There should be at least a 3" (8 cm) clearance behind the case to allow connection of the transducer and power/data cables.
- The mounting surface should be sturdy enough to support the unit and protect it from excessive vibration and shock.



NOTE: *The temperature range for the Fishfinder 250/250C is 5°F to 130°F (-15°C to 55°C). Extended exposure to temperatures exceeding this range (in storage or operating conditions) may cause failure of the LCD screen. This type of failure and related consequences are NOT covered by the manufacturer's limited warranty.*

Installation

Unit Installation



The swivel base is designed to be secured using a pan head screw or machine bolt. If you use a screw with a countersunk head, you risk damaging the Mounting Bracket.

To swivel mount the Fishfinder 250/250C display:

Tools (not included) — Drill, Screwdriver (Phillips or Standard), three #8 (4mm) pan head machine bolts with matching nuts and washers and a 5/32" (5mm) drill bit, OR three #8 pan head self-tapping screws and an appropriately-sized drill bit for drilling starter holes.

1. Using the swivel base as a template, mark the location of the three holes that are used to secure the bracket to the mounting surface.
2. If securing the base with machine bolts, drill three 5/32" (5mm) holes at the locations you marked. OR, if securing the base with self-tapping screws, drill starter holes at the locations you marked. Starter holes should generally be no deeper than half the screw length.
3. Secure the swivel base with three bolts or screws. **DO NOT OVERTIGHTEN.**
4. Place the rest of the mount over the swivel base and secure with the short knob.

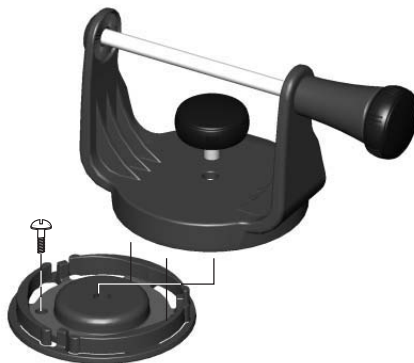

Secure the base and attach the mount

Installing the Unit on the Mounting Bracket

1. Align the slot on the back of the unit with the long mounting knob and slide in place. It may be necessary to adjust the long mounting knob to spread the bracket arms apart. (Turn counter-clockwise to widen the bracket arms, clockwise to tighten.)
2. Adjust the unit angle and tighten the long mounting knob until snug.
3. To tilt the unit, loosen the long mounting knob on the right side of the bracket assembly.
4. To rotate the entire bracket, twist it left or right. The bracket clicks as you turn it.
5. Tighten all knobs once the desired viewing angle is obtained.



Slide the unit onto the bracket



Adjust for optimal viewing

Installation

Unit Installation

Installation

Unit Installation

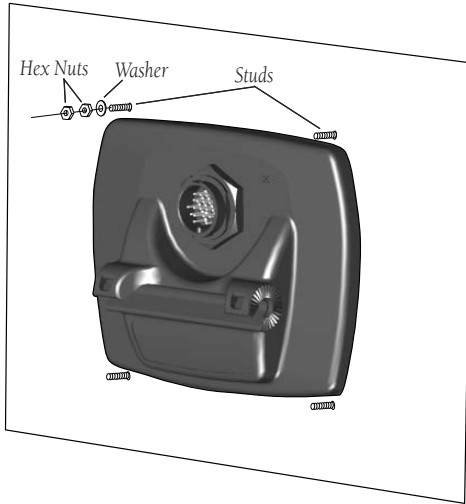

Flush Mounting the Fishfinder 250/250C Unit

The Fishfinder 250/250C can be flush mounted on a flat panel. When flush mounting the Fishfinder 250/250C, be sure to choose an appropriately sized location for the unit. Check that all cables reach the unit mounting location before beginning installation. Use the Flush Mount Template provided in the box to determine a location. Always wear safety goggles and a dust mask when drilling, cutting or sanding.

To flush mount the Fishfinder 250/250C:

Included Mounting Hardware — 4 - 3mm Studs, 4 - Flat Washers, 8 - 3mm Hex Nuts.

Tools (not included) — Center Punch, Drill, 1/8" (3mm) Drill Bit, 3/8" (6mm) Drill Bit, Jig Saw, 1/16" (2mm) Allen Wrench, 9/35" (7mm) Wrench.

1. Trim the Flush Mount Template and tape in the desired location.
2. Using a Center Punch, indent the center of each Mounting Hole location.
3. Using a 1/8" (3mm) drill bit, drill the four Mounting Holes.
4. Using a 3/8" (6mm) drill bit, drill a hole for a location to begin cutting the mounting surface.
5. Using the Jig Saw, cut the mounting surface along the inside of the dashed line indicated on the template. **Be very careful when cutting this hole, there is only a small amount of clearance between the unit and the Mounting Holes.** It may be prudent to cut slightly inside the indicated line and then sand or file the panel as needed to obtain the best fit.
6. Install the four Mounting Studs into the unit by screwing the shorter section into the back of the unit. Use a 1/16" (2mm) Allen Wrench to tighten the Mounting Studs until the stops contact the case. Be careful not to overtighten as this may damage the Mounting Stud. The studs have a reusable thread-locking patch pre-applied from the factory.
7. Place the unit in position inside the cutout area of the mounting surface.
8. Place washers over the Mounting Studs, then thread on one Hex Nut per Mounting Stud. Tighten all four Hex Nuts until the unit is snug against the mounting surface. Install and tighten the second Hex Nut on all four Mounting Studs to lock the first Hex Nut in place.

Connecting the Power/Data Cable

The power/data cable connects the Fishfinder 250/250C to a 10-35 volt DC system and provides interface capabilities for connecting external devices. The color code in the diagram (pg. 6) indicates the appropriate harness connections. If it is necessary to extend the power/data wires, use a wire of comparable size and keep your extension as short as possible.

The unit can be wired directly to your boat's battery or to an unused holder on your boat's fuse block. When connecting the unit directly to the battery, make sure the 2-Amp in-line fuse supplied with the unit is installed. If needed, use an ACG/3AG - 2 Amp replacement fuse. If you decide to use the fuse block, remove the in-line fuse holder supplied with the unit.

Installing the Wiring Harness (Basic):

1. Determine the polarity of the fuse holder using a Test Light or Volt Meter.
2. Install the Red (+) wire on the Positive Fuse Holder Terminal.
3. Install the Black (-) wire on the Negative Fuse Holder Terminal.
4. Install a 2 amp fuse in the Fuse Holder.

The Fishfinder 250/250C can be connected to another piece of NMEA compatible electronic equipment, such as a Garmin GPS (Global Positioning System). If equipped with a capable transducer, the Fishfinder 250/250C can send depth, temperature, and speed information to the NMEA device. It can also mark a location (pg. 15) that could be displayed on another device and can accept GPS navigational data (pg. 17), such as position, time, course, distance, etc. Refer to the wiring diagram on the following page for interfacing the Fishfinder 250/250C with other devices.

Installing the Wiring Harness to a GPS or other NMEA device:

1. Follow steps 1-4 of the above wiring harness installation. For Garmin units, the Ground (black) wires from both devices must be attached together or on the same fuse terminal for data ground. Refer to the wiring diagram of your GPS unit for wire identification.
2. Connect the Blue (Data Out) wire from the Fishfinder to the Data IN wire on the GPS/NMEA harness.
3. Connect the Brown (Data In) wire from the Fishfinder to the Data OUT wire on the GPS/NMEA harness.
4. Set the Fishfinder 250/250C NMEA Input/Output to 'On' (pg. 20). For Garmin GPS units, set the communications interface to NMEA/NMEA, NMEA In/NMEA Out or NMEA.

Wiring and Interfacing

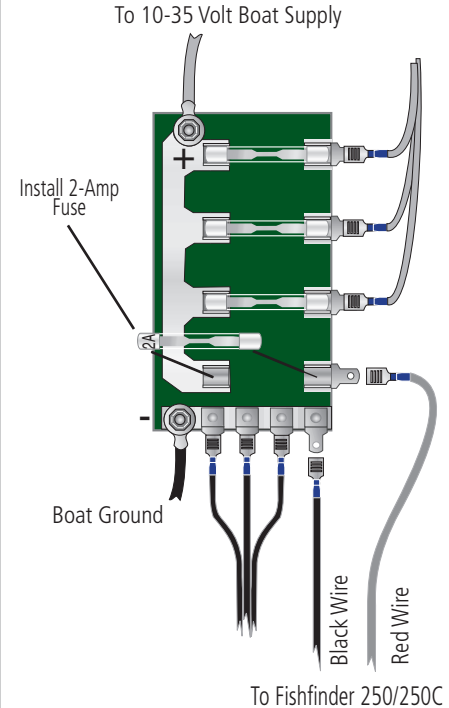

Installation

Wiring and Interfacing

You can download a copy of Garmin's proprietary communication protocol document from the Support section of our web site at www.garmin.com.

Complete information concerning National Marine Electronics Association (NMEA) format and sentences is available for purchase from NMEA at:

NMEA
Seven Riggs Avenue
Severna Park, MD 21146
U.S.A.
410-975-9425
410-975-9450 FAX
www.nmea.org

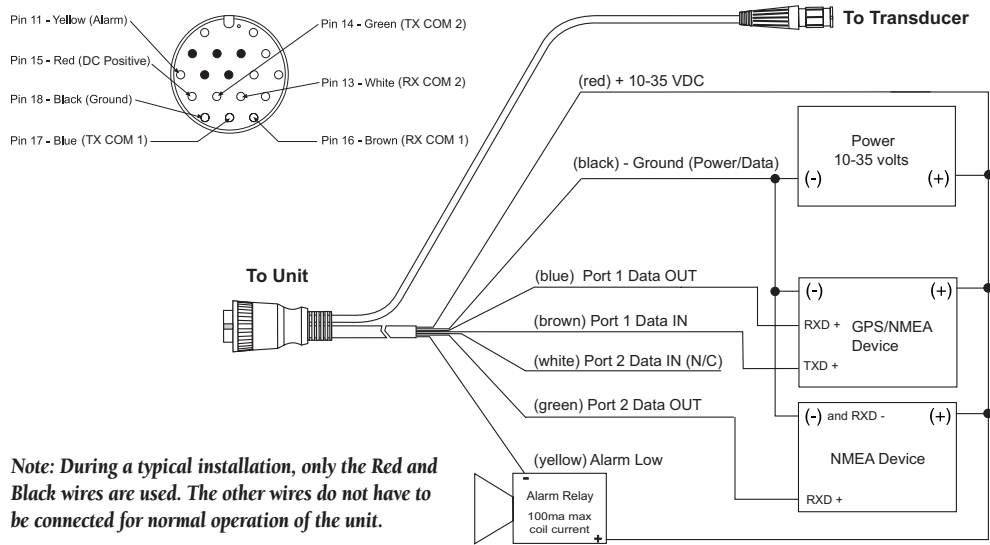

Note: During a typical installation, only the Red and Black wires are used. The other wires do not have to be connected for normal operation of the unit.

Interfacing

The Fishfinder 250/250C allows for NMEA 0183, Version 2.3 input/output with a compatible GPS or navigation device. NMEA Input/Output must be set to 'On' to send/receive data (see pg. 20). For additional information on using your Fishfinder 250/250C with NMEA devices, see pages 5, 15, and 20.

The following are the sentences for NMEA 0183, version 2.3:

Input — GPBOD, GPBWC (only used if RMB not present), GPGGA, GPGLL (only used if GGA not present), GPRMB, GPRMC, GPXTE (only used if RMB not present)

Output — SDDBT, SDDPT, SDMTW, SDVHW, SDWPL* (only if a waypoint is "marked" in Pointer Mode)

*Garmin GPS units will accept the SDWPL (WPL) NMEA sentence and create a waypoint (saved location) at that position (see pg. 15). For compatibility with other brands of GPS or NMEA capable navigation devices, check with that manufacturer to see if their unit accepts/stores NMEA 0183 SDWPL sentences/waypoints. The Fishfinder 250/250C does not store the actual waypoint. Only the receiving device, if capable, will store the waypoint.

Installing the Transducer

Proper transducer installation is key to getting the best performance from your new unit. If the transducer lead is too short, extension cables are available from your Garmin dealer. Coil and secure any excess cable. **DO NOT** cut the transducer lead or any part of the transducer cable, as this will void your warranty. The cable cannot be spliced and connected to any existing (Garmin or non-Garmin) transducer cables.

Following are some tips and basic installation instructions for some popular transducers. **Detailed installation instructions are provided in the transducer kits.** Some transducers may need to be installed by a professional marine installer.

Transom Mount Installation

Transom Mount Transducer
(depth/temp)

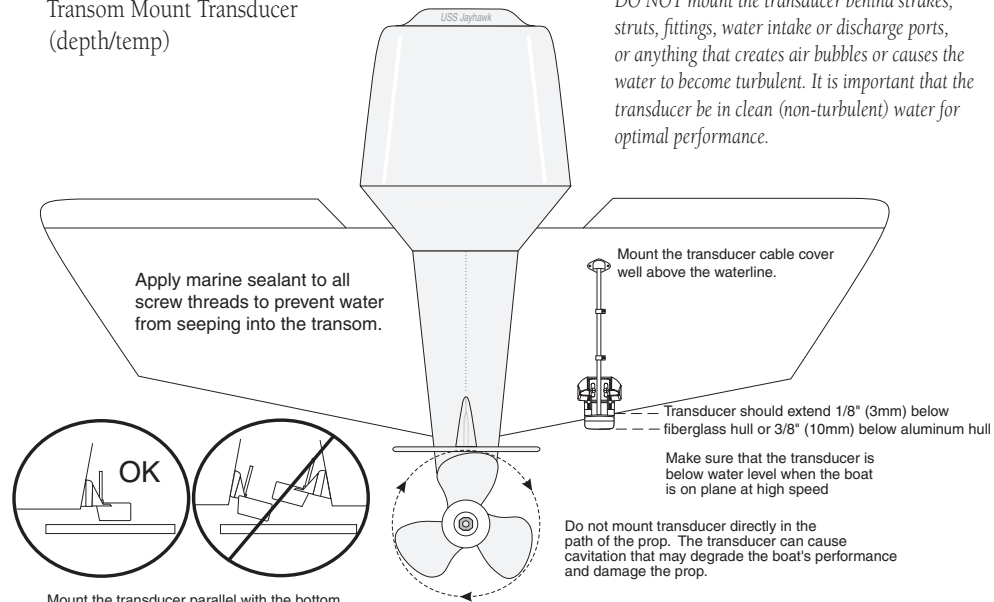

Installation

Mounting the Transducer

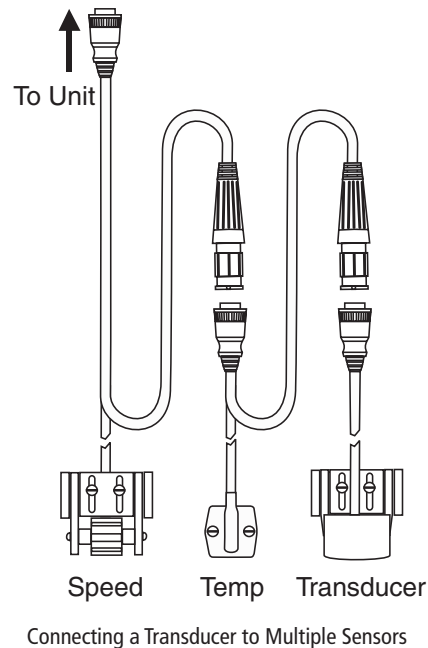

Mounting the Transducer

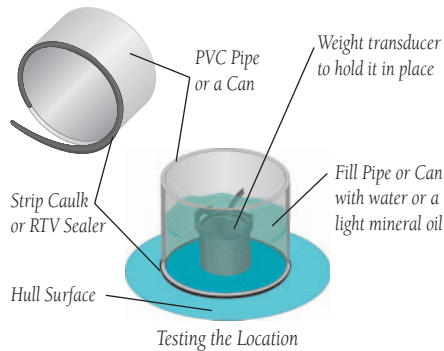

Shoot-Thru-Hull Installation

To avoid drilling a hole to mount a thru-hull transducer, a transducer may be secured with epoxy inside a boat (“shoot-thru-hull” installation). This type of installation can provide better noise reduction and allow you to use a higher gain setting. For a transducer to be mounted inside the hull (shoot-thru, not thru-hull), the boat must be fiberglass, with no core. Contact your boat manufacturer if you are unsure. Professional installation may be necessary. Be sure to always wear a dust mask and safety goggles when installing.

Some transducers are specifically designed to be mounted inside a fiberglass hull. The standard plastic transom mount transducer can also be mounted in this fashion using the following method. If using a temperature sensing transducer, the temperature displayed reflects the hull temperature.

Selecting a location:

1. The location has to be solid fiberglass, devoid of any air bubbles, laminates, fillers or dead air space. The location needs to be in an area of clean water at all speeds. Do not place the transducer over any strakes or behind any obstruction on the hull that would create turbulence at speed.



NOTE: Many modern hulls have a prelocated pocket for shoot-thru-hull transducer installation. If you are unsure if your hull is equipped with a pre-located pocket, contact your hull manufacturer.

Testing the location:

1. Fabricate a test device from a section of PVC pipe or a can, as shown in the side bar.
2. Temporarily seal the test device to the hull with caulking or RTV sealer, and fill with water or light mineral oil.
3. Place the transducer in the water, pointed directly at the bottom. Weight it down. Set unit for optimum performance. If the sonar performance is significantly degraded, find and test another location.

Permanently installing the transducer:

1. Lightly sand the surface of the hull and face of the transducer with 400 grit wet or dry sandpaper.
2. Build a dam using strip caulk about 1/4” (6mm) tall. Pour about 1/8” (3mm) of two part, slow cure epoxy in the dam.
3. Place the transducer in the epoxy, turning the transducer to work out any air bubbles.
4. Weight the transducer in place and allow to cure for 24 hours.

Testing the Installation

While it is possible to perform some checks with the boat trailered, the boat should be in the water to properly test the sonar portion of the installation.

Press the **POWER/BACKLIGHT** key (see pg. 10) and the Fishfinder 250/250C should power on. If the unit fails to power on, verify that the wiring adapter is seated properly in the back of the unit, the Red and Black wires are connected to the correct polarity, and that the 2-Amp fuse is installed and not blown. If the unit is connected to a power supply that exceeds 35 volts DC, a "Battery Voltage High" warning is displayed and the unit turns off. If the unit does not detect a transducer, it automatically enters Simulator Mode.

When the unit detects a transducer on initial power up, a "Please set up transducer" message is displayed. Press the **ENTER** key (see pg. 10) to select the transducer type. Highlight your transducer type with the **ARROW** keys and press **ENTER**. Press **ADJ/MENU** to return to the Sonar display.

Since water is necessary to carry the sounder's sonar signal, the transducer must be in the water to work properly. It is not possible to get a depth/distance reading when out of the water. As the unit powers on, it should immediately start showing the bottom. Verify that the unit is not in the simulator mode. If the unit is in the simulator mode, make sure that the transducer is connected properly to the unit. When you place your boat in the water CHECK FOR LEAKS around any screw holes that have been added below the water line. DO NOT leave your boat in the water for an extended period of time without checking for leaks.

Begin testing the installation at a slow speed. If the sonar appears to be working properly, gradually increase the boat's speed while observing the sonar's operation. If the sonar signal suddenly is lost or the bottom return is severely degraded, note the speed at which this occurs. Return the boat to the speed the signal was lost. Make moderate turns in both directions and see if the signal improves. If the signal strength improves while turning, adjust the transducer so that it extends another 1/8" (3mm) below the transom of the boat. It may take several adjustments to eliminate the degradation. If the signal does not improve, it may be necessary to move the transducer to a different location.



NOTE: When adjusting the depth of the transducer, make the adjustments in small increments. Placing the transducer too deep can adversely affect the boat's performance and put the transducer at greater risk of striking underwater objects.

Installation

Testing the Installation

Using the Keypad

The keypad contains the following keys:

Keypad Usage

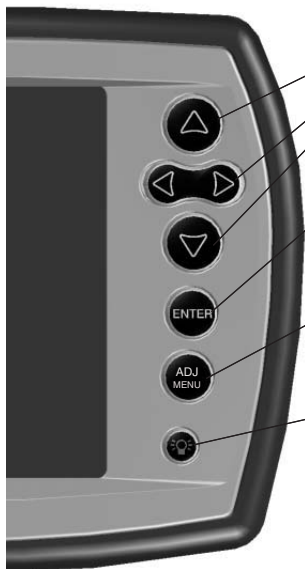

NOTE: Always press and release a key to perform its primary function. Pressing and holding a key will activate its secondary function (if available).

ARROW Keys— used to select (highlight) menu options and enter data. Also control movement of the cursor when paused in Pointer mode. Allow direct control of Sonar Page Adjustments.

ENTER Key— selects a highlighted menu option. When entering data, allows you to initiate entry and then accept the selected value(s). When paused in Pointer mode, press to create a waypoint at the Pointer position (if interfaced with compatible NMEA GPS).

ADJ/MENU Key— from the sonar screen, press and release to display the Adjustment Menu. Press and hold to access the Main Menu for unit configuration. From either menu, press and release to return to the sonar page.

POWER/BACKLIGHT Key— press and hold to turn the unit on and off. While the unit is on, press and release to display the light/contrast adjustment window.

To change the backlight/contrast settings:

1. Press and release **POWER/BACKLIGHT** to display the light/contrast adjustment window. The adjustment window automatically disappears when idle for 20 seconds.
2. Press the UP or DOWN **ARROW** keys to change the backlight setting. Press and release **POWER/BACKLIGHT** to toggle the backlight setting between maximum, user-set, and minimum brightness levels.
3. Press the LEFT or RIGHT **ARROW** keys to change the contrast setting.
4. Press **ENTER** to return to the Sonar Page.

Sonar Page

The Sonar Page is where your Fishfinder 250/250C becomes a powerful fishfinder/flasher. If the unit does not detect a transducer, a “Sonar Turned Off” message is displayed on the Sonar Page. If in Simulator mode, a “Running Simulator” message is displayed.

The currently selected Adjustment option (see pg. 12) is displayed in the top left of the screen. Directly below the Adjustment option, the screen displays numeric data such as Depth, Water Temperature and Water Speed (see pg. 17-18). The middle of the page contains a right-to-left moving sonar image of the water beneath your boat. (**NOTE:** Items appear as they pass under your transducer. Items on the right side of the screen are closer to you than those on the left.) Along the right side of the screen is a scale which reflects the depth of the area being displayed.

The display may also be set to show a split screen view of a zoomed portion of the sonar, bottom lock (display scaled from the bottom up), or a combination of these options (see pg. 13). For example, you may choose to show dual frequency at a 2X zoom (Dual 2X) on one half of the screen, with normal range dual frequency (Dual) on the other half. The current display mode is shown at the bottom of each sonar display.

The Fishfinder 250 displays sonar returns as shades of gray; stronger returns are darker, and weaker returns are lighter. On the Fishfinder 250C, sonar returns are displayed as red (strongest), then orange (strong), yellow (medium), green (weaker) and blue (weakest).

The ‘Fish Symbols’ option (see page 16) allows you to find fish by viewing the actual sonar data, a fish symbol or a combination of both. ‘Fish Symbols’ appear as black on the Fishfinder 250 and green on the Fishfinder 250C. When the unit is set to ‘Dual’ frequency mode (see page 14), the appearance of the fish symbols (and simulated fish returns) will change. Fish symbols from the narrower beam (200kHz) will be solid (narrow returns), but the returns from the wider beam (50kHz) will be hollow (wide returns). Simulated fish icons are displayed in three different sizes based on the size of the return. Actual fish returns may not always appear as perfect arches, due to the speed, fish orientation, and/or other conditions.

For more information on understanding the sonar, see pages 23-25.

Unit Operation

Understanding the Display

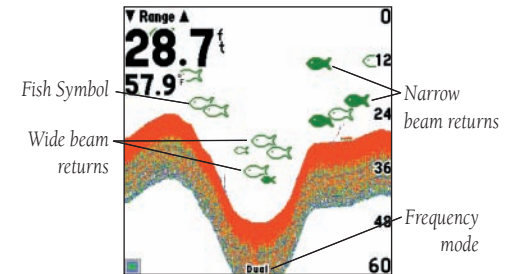
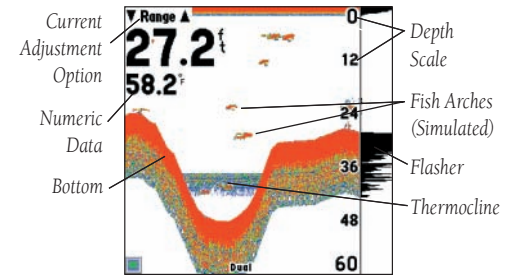

Adjustment Menu Options

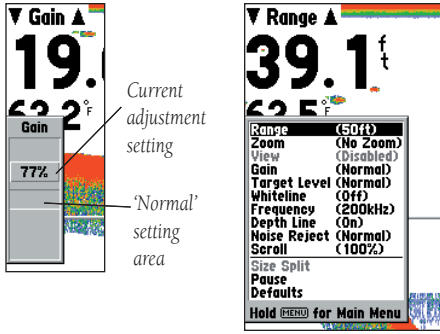

Adjustment Menu options

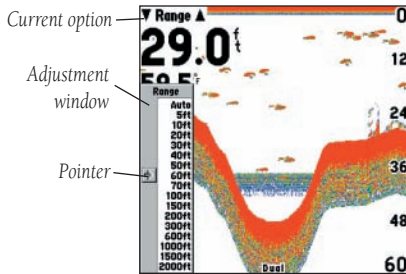

Using the Adjustment Menu

The Adjustment Menu allows direct access to the settings and features most commonly used on the Sonar Page. There are 10 main adjustment options available: Range, Zoom, View, Gain, Target Level, Whiteline, Frequency, Depth Line, Noise Reject, and Scroll. All adjustments may be made by using the **ARROW** keys and **ENTER** key. The currently selected option will appear in the upper left of the display with an up and down arrow on each side of the name.

To change an Adjustment Menu setting:

1. Press **ADJ/MENU** to display a list of all options and their current settings. The adjustment window automatically disappears when idle for 20 seconds or you may press **ADJ/MENU** to exit.
2. Press the UP or DOWN **ARROW** keys to highlight the desired option and press **ENTER** to display the Adjustment window.
3. Press the UP or DOWN **ARROW** keys to move the setting bar (or pointer) to the desired percentage (Off, 1-100%), setting or range. When changing most adjustments, an open space is displayed on the scale to indicate the 'Normal' or default setting. Once set to 'Normal', the setting bar is replaced by the word 'Normal'.
4. Press **ENTER** to accept the new setting and return to the Sonar Page.

The current adjustment option is displayed in the upper left corner of the screen. For fast adjustment from the Sonar Page, press the LEFT or RIGHT **ARROW** keys to scroll through the options, then press the UP or DOWN **ARROW** keys to immediately change the current option or press the **ENTER** key to review the current setting before making changes.

Adjustment Options

The Adjustment Menu allows direct access to the settings and features most commonly used. These available adjustments are:

- **Range** — sets the display depth range used for viewing. The unit can be set to automatically track the bottom or set to a user-specified depth range (see "Custom Range" pg. 16).
- **Zoom** — used to quickly select a display zoom scale or to split the display. When a scale other than 'No Zoom' is selected, the 'View' or 'Span' options are activated in the Adjustment Menu.

The Zoom function has seven settings:

No Zoom — Displays the sonar picture with no zoom.

2x Split — Shows two reduced-size sonar pictures at the same time. The right half of the display screen shows the complete sonar picture at its original scale. The left half shows a portion of the original picture at 1/2 depth scale.

2x Zoom — Displays the 2x zoomed picture on the full screen and does not show the original scale picture.

4x Split — Shows two reduced pictures, the right at the original depth scale and the left at 1/4 the original depth scale.

4x Zoom — Displays only the 4x zoomed picture on the full screen.

Btm (Bottom) Split — Shows two reduced pictures, the right at the original depth scale and the left showing only sonar returns close to the bottom. The bottom is displayed as a flat line across the bottom of the screen, and returns are shown at their distance from the bottom up. You can adjust the scale of the Bottom Split display by changing the Span setting (see below).

Btm (Bottom) Lock — Displays the Bottom Lock (returns close to the bottom, shown at their distance from the bottom up) picture on the full screen. You can adjust the scale of the Bottom Lock display by changing the Span setting (see below).

- **View/Span** — available when a Zoom scale other than 'No Zoom' is selected. The 'View' or 'Span' setting is used to change the viewing range of a zoomed display. The 'View' option is enabled when the display is set to 2x Split, 2x Zoom, 4x Split, or 4x Zoom. If the display is 2x or 4x split, only the zoomed portion on the left side of the display is affected by the change. If the display is Bottom Split or Bottom Lock, the 'Span' option is enabled to adjust how far off the bottom the unit displays data.

- **Gain** — controls the sensitivity of the unit's receiver. This provides some flexibility in what is seen on the display. To see more detail, increase the receiver sensitivity by selecting a higher gain percentage. If there is too much detail or if the screen is cluttered, lowering the sensitivity may increase the clarity of the display.

- **Target Level** — adjusts which colors (Fishfinder 250C) or shades of gray (Fishfinder 250) are used to display sonar information. A Color Bar (see pg. 17) is displayed on the right side of the screen as you adjust this setting. A higher percentage results in more strong-signaled colors or shades (see pg. 11) displayed on the Sonar Page. A lower percentage results in more weaker-signaled colors or shades (see pg. 11) displayed on the Sonar Page. This setting does not increase/decrease the unit Gain.

Adjustment Menu Options

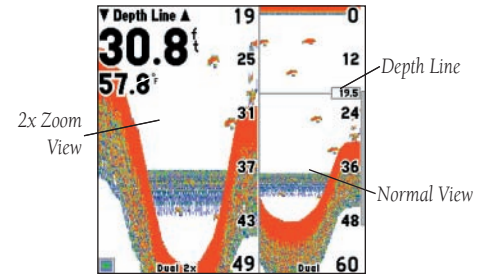

Sonar 2x Split Screen
(shown with Depth Line)

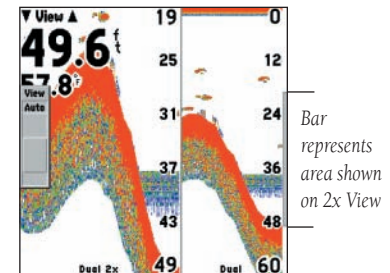

Sonar View Adjustment

Unit Operation

Adjustment Menu Options

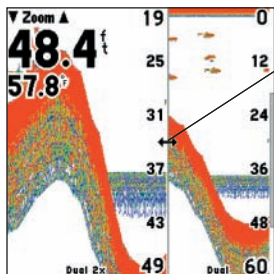

Resizing the Sonar Split

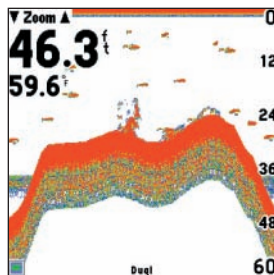

The current frequency setting will display at the bottom of the screen.

• **Whiteline** — controls how the unit displays information about the bottom type (hard or soft). With the Whiteline ‘Off’, all high-intensity bottom returns are displayed as red on the Fishfinder 250C and black on the Fishfinder 250. With Whiteline set at ‘Normal’ or 1-100%, this option can be used to better determine bottom hardness. See page 26 for more information on this feature.

• **Frequency** — allows you to choose a sonar operation frequency. Frequency refers to the “pitch” of the sound that the transducer sends and receives. You may choose ‘200kHz’, ‘50kHz’ or ‘Dual’ frequency (when using a dual frequency transducer).

• **Depth Line** — adds a horizontal depth line across the display to measure the depth of underwater objects. The depth of the line is displayed in a box on the right side of the line. When the Depth Line adjustment window is visible, press the UP or DOWN **ARROW** keys to control the position of the line on the graph.

• **Noise Reject** — helps filter unwanted noise from the graph. The ‘Noise Reject’ tool can be turned ‘Off’, set to ‘Normal’ (automatically adjusts for optimum viewing) or to a fixed 1-100% setting. **NOTE:** the HIGHER the noise rejection setting, the more likely the unit is to NOT show fish or structure.

• **Scroll** — adjusts the rate that the graph scrolls from right to left. If you are sitting still or the graph is moving too fast, slowing the scroll rate or pausing it can be beneficial. ‘Auto’ automatically adjusts the scroll rate according to the boat’s speed. (See also ‘Automatic Scroll Speed Limit’ on page 21.)

• **Size Split** — enables width adjustment of the Sonar Page split screen. This option is only available when a split zoom is selected. You may adjust the size of the split window anywhere from 1/4 to 3/4 width from the right half of the Sonar Page.

To resize the Sonar Page split screen:

1. From the Sonar Page split screen, press **ADJ/MENU**.
2. Using the **ARROW** keys, highlight the ‘Size Split’ option and press **ENTER**. A small double-arrow is displayed in the middle of the split line on the screen.
3. Press the LEFT or RIGHT **ARROW** keys to move the split line to the desired position, then press **ENTER**.

• **Defaults** — restores Adjustment Options back to original factory settings.

Pausing the Sonar Page

You may pause the Sonar Page to stop it from scrolling. The paused screen allows you to take a better look at sonar returns. When in this mode, the word “Paused” is displayed at the bottom of the screen and a Pointer cursor is activated. You may move the Pointer around on the paused sonar graph in order to reference sonar items and mark waypoints for that location (if attached to a Garmin GPS or compatible NMEA navigation device. See pg. 5.) A data field is displayed at the top of the graph with the Pointer’s depth, surface temperature for that position, and GPS coordinates (if available). This makes it easier to find and use objects such as stumps, rocks, or brush piles for future fishing locations. The depth continues to update while the display is paused, but the unit will not show any new sonar data until the Sonar display is unpaused (resumed). You may see a discontinuity from where the sonar information stops to where it starts again.

To pause and unpause the Sonar display:

1. From the Sonar Page, press **ADJ/MENU**.
2. Using the **ARROW** keys, highlight the ‘Pause’ option and press **ENTER**. The Sonar display is paused. The Pointer cursor is activated, and data fields for the Pointer are displayed at the top of the screen.
3. To unpause the Sonar display, press **ADJ/MENU**, highlight the ‘Resume’ option and press **ENTER**.

To mark an underwater waypoint:

1. With the Sonar display paused, use the **ARROW** keys to move the cursor onto the target (underwater drop off, stump, etc.) you want to mark. A data field is displayed with the cursor’s depth, surface temperature for that position and GPS coordinates.
2. Press **ENTER**. The New Waypoint window is displayed with a default three-digit name and pointer’s coordinates automatically filled in.
3. To change the name, highlight the name field and press **ENTER**. Make your changes using the **ARROW** keys and press **ENTER** when done.
4. When finished, move the field highlight back to the ‘OK’ prompt and press **ENTER**. The unit sends a NMEA WPL sentence to an attached GPS unit or NMEA navigational device (see pgs. 5-6).

Unit Operation

Pausing the Sonar Page

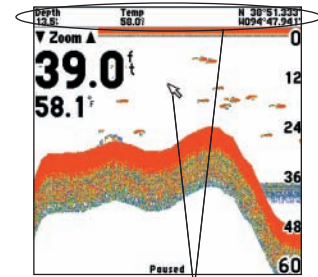

As you move the Pointer, the Depth, Temp and Position (if available) is displayed at the top of the screen.

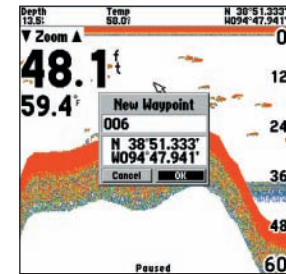

You may send an underwater waypoint to a GPS unit.

Unit Operation

Main Menu Options

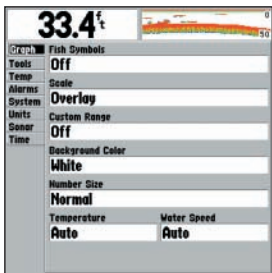

Main Menu - Graph Tab

Off

Fish Symbols Off— All available information is displayed.



Suspended targets are displayed as fish symbols. Background information is displayed.



Same as above with the target depth attached.



Suspended targets are displayed as fish symbols. No background information is displayed.



Same as above with target depth attached.

Main Menu

The Main Menu contains the unit settings that usually do not require frequent change. The Main Menu is divided into eight tabs: Graph, Tools, Temp, Alarms, System, Units, Sonar and Time. Each tab is described in more detail in this section.

To enter the Main Menu, press and hold the **ADJ/MENU** key. The first time you enter the Main Menu, the 'Graph' tab is highlighted in black. Press the UP or DOWN **ARROW** keys to highlight different tab selections. Press the RIGHT **ARROW** key to access the selection fields. Each time the Main Menu is accessed, the unit returns to the last edited selection field. Press the LEFT **ARROW** key to get back to the tabs.

To change a setting on a Main Menu tab:

1. Using the **ARROW** keys, highlight the desired field and press **ENTER**.
2. Highlight the desired setting and press **ENTER**.
3. Press **ADJ/MENU** to return to the Sonar display or to cancel data entry.

Graph Tab

The Graph Tab allows you to determine the appearance of the scrolling graph display and contains the unit settings that usually do not require frequent change.

The following settings are available:

- **Fish Symbols** — allows you to determine how the graph shows underwater targets and background information. If Fish Symbols are set to 'Off', the unit displays all of the available information about the underwater environment. If a fish symbol is selected, the graph displays only the information related to that symbol. Actual fish returns may not always appear as perfect arches (like in simulator mode), due to the speed, fish orientation and/or other conditions.
- **Scale** — controls the presentation of the depth 'Scale' displayed vertically along the right side of the graph. The depth 'Scale' can be configured to display four different ways: 'Overlay', 'Corners', 'Basic' or 'No Scale'.
- **Custom Range** — allows you to specify a custom viewing range/scale. Once enabled, this range is displayed as 'Custom' in the 'Range' adjustment control. The left value is the top of the scale and the right value is the bottom of the scale.

- **Background Color (Fishfinder 250C only)** — allows you to change the background color of the sonar display. Choices are Black, Blue or White.
- **Number Size** — allows you to choose between a Normal or Large sized Basic depth/temp/speed display. This does not change the Advanced data field number sizes.
- **Temperature and Water Speed** — hides or displays temperature and water speed on the Sonar Page. When set to 'Auto', the unit automatically displays this information only if it is received from the transducer.

Tools Tab

Controls the display of useful sonar tools. The following settings are available:

- **Flasher** — this option activates a graphic Flasher representation, displayed on the right side of the graph. The graphic Flasher displays structure and bottom returns much the same as a true Flasher. You may find this feature particularly useful when using 'Fish Symbols' (see pages 11 and 16).
- **Color Bar** — shows a gradient scale of the current Target Level setting (see page 13).
- **Temperature Graph** — toggles On or Off the display of a temperature graph on the Sonar Page.
- **Advanced Data Fields** — toggles On or Off the Advanced data fields on the Sonar Page
- **Configure Advanced Data Fields** — activates the Advanced Data Field Setup screen

Configuring Advanced Data Fields

The top left of the screen contains configurable data fields for the sonar display. By default, the Basic display shows the depth, water temperature and speed (depending on the Graph Tab settings and type of transducer/sensors attached). The 'Configure Advanced Data Fields' option in the Tools Tab allows you to customize the data fields that are displayed. The Advanced display shows a larger, configurable data field with a white background. The Data Field Setup screen allows you to specify the type of data displayed and either a Narrow (Small) or Wide (Larger) size format for each data field.

The following selections require the proper NMEA data (see pgs. 5-6) in order to display information in a data field: Bearing, Compass, Course, Distance to Next, Off Course, Pointer, Position, Speed, Time Of Day, Track, Turn, and VMG. NMEA Input/Output must also be enabled to receive this data (see pg. 20).

Main Menu Options

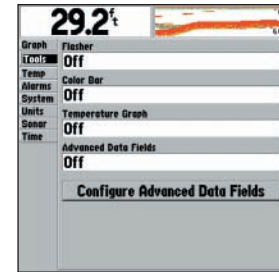

Main Menu - Tools Tab

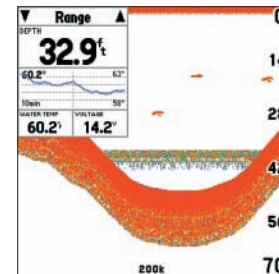

Sonar Page With
Advanced Data Fields

Unit Operation

Main Menu Options

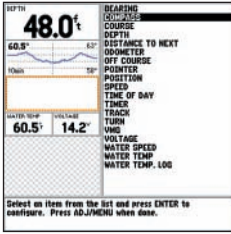

Data Field Setup screen



Modifying a Data Field



Main Menu - Temp Tab

To toggle the data field display:

1. Use the **ARROW** keys to highlight the 'Advanced Data Fields' field and press **ENTER**.
2. Select 'On' or 'Off' and press **ENTER**.

To access the Advanced data setup:

1. Use the **ARROW** keys to highlight 'Configure Advanced Data Fields' and press **ENTER**.

You may either directly edit an existing field on the left or add a new data field from the list on the right. Highlighted items on the right are displayed with a black background and the associated field on the left is outlined with a moving dotted line.

To modify or add a data field:

1. Using the **ARROW** keys, press LEFT to modify an existing field or RIGHT to add a new one, then UP or DOWN to highlight the desired item. Press **ENTER** and the available options will appear on the right.
2. Select an option from the list on the right and press **ENTER**. You may choose to display a 'Wide' or 'Narrow' sized format (some data fields are only available in 'Wide' format and this option will be grayed out), arrange the display order with 'Move Up' or 'Move Down' (Narrow data fields always arrange below Wide data fields), 'Remove' or 'Replace' the data field. For 'Replace', choose a replacement item from the list and press **ENTER**.
3. Highlight 'OK' and press **ENTER** to save changes.

Temp (Temperature) Tab

Displays the water temperature log (if equipped with a temperature transducer/sensor). The graph reads from right to left, so that the most recent temperature measured is displayed on the far right side of the graph. The dotted lines within the graph indicate intervals in the temperature scale and the duration of time. The following settings are available:

- **Log and Graph Scale** — sets the temperature range (in degrees) for displaying the log. Select 'Auto' to have the unit determine the best range, or select a span of 2, 4, 6, 8 or 10 degrees.
- **Reset (Scale)** — resets the scale range for the temperature graph. Useful when the scale spans a large range due to extreme temperature changes. Only shows if Log and Graph Scale is set to 'Auto'.
- **Log Duration** — sets how fast or slow the temperature log scrolls; the shorter the time duration, the faster the temperature log scroll. Select a duration from 1 minute to 2.5 hours.

Alarms Tab

Contains settings for the unit's alarms. (For a list of alarms and unit messages, see page 28.) The Alarms Tab is divided into two submenu tabs: Sonar alarms and System alarms.

Sonar alarms:

- **Fish** — sets alarm/icon to sound/display when unit detects a fish of the specified symbol size.
- **Shallow Water/Deep Water** — set alarms to sound when you enter an area of specified depth that is too shallow and/or too deep.
- **Drift** — sets an alarm to sound when you've exceeded a specified drift depth range. For example, if the value is set to 5 ft. and the current depth is 20 ft., the alarm will sound if the unit detects a depth greater than 25 ft. or shallower than 15 ft.
- **Water Temperature** — sets an alarm to sound when the transducer reports a temperature either above, below, inside or outside the specified values.

System alarms:

- **Battery** — sets an alarm to sound when the battery is reaching a critical state of discharge.
- **Timer** — allows you to choose between a Count Dn (Down) or Count Up timer. You may specify a duration for the Count Dn (Down), Stop, or Reset the timer.

To set an alarm:

1. Use the **ARROW** keys to highlight desired submenu tab of the Alarms Tab.
2. Highlight the field below the alarm name you wish to activate and press **ENTER**.
3. Change the mode to the desired setting and press **ENTER**.
4. Highlight the next field to the right and press **ENTER**, then enter the desired settings and press **ENTER** to finish.
5. If you want the alarm to display and beep until acknowledged, highlight the 'Persist' box and press **ENTER** to place a check mark in the box.

Unit Operation

Main Menu Options

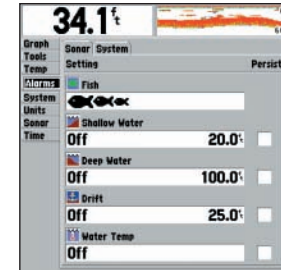

Main Menu -
Alarms/Sonar Tab



Main Menu -
Alarms/System Tab

Unit Operation

Main Menu Options



Main Menu - System Tab

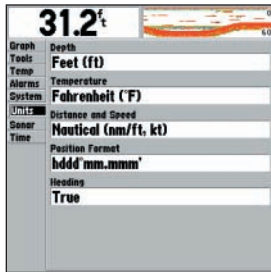

Main Menu - Units Tab

System Tab

Controls various system and interface settings. The following settings are available:

- **Beeper** — controls audible beep. Select from 'Off', 'Alarms Only' (sounds for alarms/messages), or 'Key and Alarm' (sounds for key presses and alarms/messages).
- **Display Mode** — select 'Fishfinder' to display the scrolling sonar image on the Sonar Page, or select 'Depth Sounder' to show only numeric data for Depth, Water Temp, and Water Speed.
- **Language** — select from various languages for the unit's on-screen display.
- **Simulator** — lets you simulate unit operation using a Depth Only, Depth/Temp, Depth/Speed, or Depth/Temp/Speed transducer. If prompted, choose 'No' to the retail demonstration mode for normal consumer simulator use. If the unit does not detect a transducer, it will automatically enter Simulator Mode. While in Simulator mode, a 'Running Simulator' message appears after 2 minutes of inactivity.
- **NMEA Input/Output** — controls the input/output of NMEA 0183 version 2.3 data to/from the unit. This setting must be 'On' in order to receive GPS navigational data and send Sonar NMEA data. See pages 5-6 for details on available NMEA sentences.
- **Factory Settings** — restores all settings to the original factory default values for the entire unit.
- **Software Version** — displays the unit's software version and electronic serial number.
- **Reset Odometer** — *this will only appear if you are using a speed-capable transducer/sensor*: Resets the odometer field back to zero. See "Configuring Advanced Data Fields" on p. 17 for more information.

Units Tab

Defines units of measure. The following settings are available:

- **Depth** — select units of measure for depth in Feet (ft), Fathoms (fa), or Meters (m).
- **Temperature** — select units of measure for temperature in Fahrenheit (°F) or Celsius (°C).
- **Distance and Speed** — select units of measure for distance and speed readouts in 'Nautical' (nm/ft, kt), 'Nautical' (nm/m, kt), 'Statute' (mi, mh) or 'Metric' (km, kh) terms.
- **Position Format** — changes the coordinate system in which a position reading is displayed. The default format is latitude and longitude in degrees, minutes, and thousandths of a minute (hddd°mm.mmm'). The following additional formats are available: Latitude/longitude in decimal degrees (hddd dddd°) and Latitude/longitude in degrees, minutes, and seconds (hddd°mm'ss.s").

- **Heading** — select the reference used in calculating heading information for the the following Advanced data fields: Bearing, Compass, Course, and Track (see pg. 17-18). 'True' will display data with reference to True North. 'Magnetic' will display data with reference to Magnetic North using the magnetic variation value received in the RMC NMEA sentence (see pgs. 5-6).

Sonar Tab

Allows you to set up initial settings and calibrations. The following settings are available:

- **Water Type** — since sound waves travel through 'Fresh' and 'Salt' water at different rates, it is necessary to select the 'Water Type' to ensure accurate readings on the unit.
- **Depth Number** — controls the efficiency of the digital depth update rate. 'Fast Sonar Update' updates quicker and is recommended for low-noise, deeper water (>50 ft.). 'Auto' is best for shallow water or high noise areas, has a slower screen update, and is best used if you travel a wide variety of depths. If the unit is unable to track the bottom for any reason, the digits in the depth window flash on and off to alert you.
- **Automatic Scroll Speed Limit** — automatically adjusts the Scroll rate (see pg. 14) to the speed of your vessel (if equipped with a speed sensor or receiving GPS NMEA input). Entering your maximum cruising speed will produce a 100% scroll rate when you reach that speed. One half of that speed will produce a 50% scroll rate, etc.
- **Keel Offset** — allows you to offset the surface reading for the depth of a keel in order to measure depth from the bottom of your keel instead of from the transducer's location. Enter a positive number to offset for a keel. It is also possible to enter a negative number to compensate for a large vessel that may draw several feet of water. The 'Keel Offset' will be reflected in the depth reading.
- **Transducer Type** — does not appear in Simulator Mode. Allows you to specify what type of transducer you are using. 'User Defined' is reserved for future use. Do not use unless instructed.
- **Calibrate Water Speed** — this will only appear if you are using a speed-capable transducer/sensor. Calibration is required to ensure that the Water Speed displayed on your unit is accurate. The unit automatically uses GPS ground speed (if available via NMEA input) for comparison on the calibration. If a GPS ground speed is not available, use either your boat's speedometer reading (not always

Main Menu Options

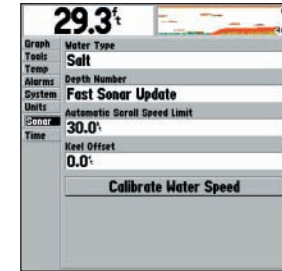

Main Menu - Sonar Tab

Transducer at Surface

Enter (+) positive Keel Offset number to show depth from bottom of keel

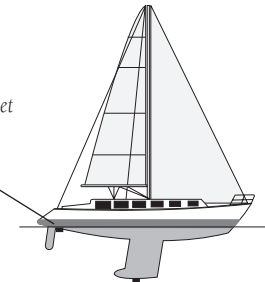

Transducer at Bottom of Keel

Enter (-) negative Keel Offset number to show depth from surface

Unit Operation

Main Menu Options

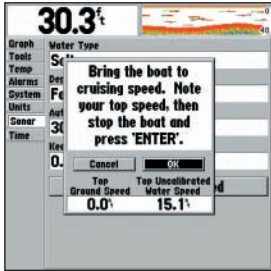

Calibrating the Speed Sensor



Main Menu - Time Tab

accurate) or a stopwatch to determine your speed over a certain distance (distance / time = speed). It is recommended that the calibration take place in water having little or no current.

To calibrate the water speed:

1. Use the **ARROW** keys to highlight 'Calibrate Water Speed' and press **ENTER**.
2. Bring the boat to a cruising speed. Both the top GPS ground speed and uncalibrated water speed will be shown at the bottom of the calibration window. Note your top speed, then stop the boat and press **ENTER**.
3. By default, the top speed will automatically show in the 'What was your top water speed?' field. If a ground speed is not available, the top uncalibrated water speed is used instead. If the new speed is correct, highlight 'OK' and press **ENTER**. To manually enter a calibration, press **ENTER** on the speed field, enter a new speed and press **ENTER**.



If the boat is not moving fast enough or the speed sensor is not registering a speed, a "Boat Is Not Moving Fast Enough To Calibrate" message is displayed at the bottom of the screen. Check that the speed sensor wheel is moving or safely increase boat speed. If there is a problem with the speed sensor/unit or if a speed sensor is not installed, a "Water Speed Sensor Is Not Working" message is displayed at the bottom of the display. Check connections of speed sensor cables.

Time Tab

Displays the current time and date, allows you to adjust the 12 or 24 hour time format, select a time zone and adjust for daylight saving to show correct local time. The time will only display if you are receiving valid NMEA input from a GPS unit (see pgs. 5-6) or in simulator mode. The following settings are available:

- **Time Format** — choose from 12 or 24 hour (military) time format.
- **Time Zone** — choose your correct time zone to show correct local time or enter a UTC (also called Greenwich Time) Offset. The UTC offset is how many hours you are ahead or behind the time line.
- **Daylight Saving Time** — choose from 'Auto', 'On', or 'Off' to adjust for daylight saving.
- **Current Time** and **Current Date** — display current time and date. Fields will be blank if not receiving a time from an attached GPS. It is not possible to edit these fields.

Understanding Sonar

If you are unfamiliar with basic sonar, or need help determining what is displayed on the graph, this section may be for you. This section is intended to help the novice user gain some understanding of how the Fishfinder 250/250C operates and how it can help improve their fishing productivity.

To understand what the unit is displaying, it is important to have a general knowledge of how the unit works and how it determines what to display. Basically, the unit operates by transmitting sound waves toward the bottom of a lake, stream, or seabed in a cone-shaped pattern. When a transmitted soundwave strikes an underwater object such as the bottom, a piece of structure, or a fish, sound is reflected back to the transducer. The transducer collects the reflected sound waves and sends the data to the unit to be processed and displayed on the graph. The underwater data is displayed on the graph in the order that it is returned: first returned—first on the graph. The diagram below demonstrates this by showing an underwater scene as it would be displayed on the graph. Generally speaking, if the only thing between the transducer and the bottom is water, the first strong return will come from the bottom directly below the transducer. The first strong return sets the bottom level. Weaker secondary returns provide the detailed data. The Fishfinder 250 displays sonar returns as shades of gray; stronger returns are darker, and weaker returns are lighter. On the Fishfinder 250C, sonar returns are displayed as red (strongest), then orange (strong), yellow (medium), green (weaker) and blue (weakest).

The following pages will show how this data can help you to improve your fishing.

This fish is currently in a dead zone and is not detected by the sonar. The fish is in the coverage area of the transducer, but remember— the first strong return sets the bottom level. The fish will eventually be detected when the first strong return sets the bottom level below the fish.

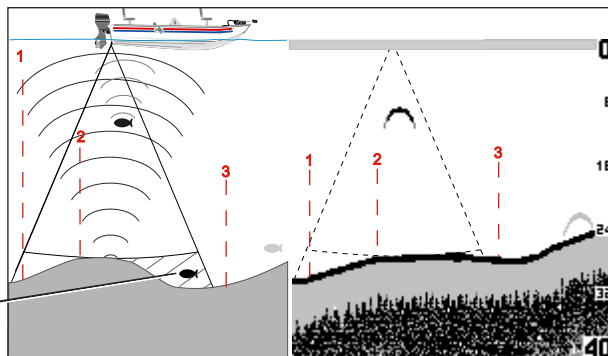

Understanding Sonar

Transducer Coverage

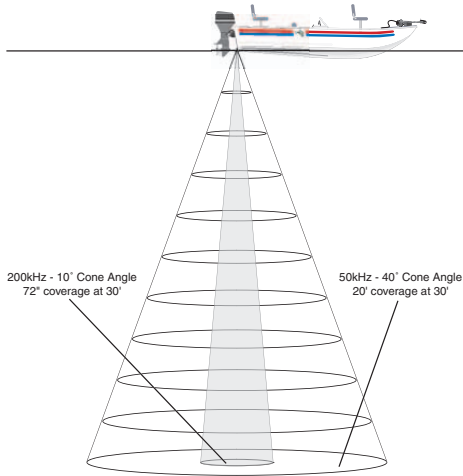

Transducer Coverage

The area covered by the transmitted sound waves is determined by the cone angle of the transducer and the water depth. Cone angles may vary between different types of transducers. For example, a 50kHz frequency may provide a “wide” 40° cone angle, with a coverage width that is approximately 2/3 of the water depth. As shown in the diagram on the left, the 40° cone angle (50kHz frequency) approximately covers the area of a 20 foot diameter circle at a 30 foot depth. A 200kHz frequency may provide a “narrow” 10° cone angle, with a coverage width that is approximately 2/10 of the water depth. As shown, the 10° cone angle (200kHz frequency) approximately covers the area of a 6 foot diameter circle at a 30 foot depth.

When using the Fishfinder 250/250C in ‘Dual’ frequency mode, the unit alternately transmits 50kHz and 200kHz signals and combines the information. The ‘Dual’ frequency capability of the Fishfinder 250/250C allows the user to have a large coverage area and still retain good bottom resolution. When in ‘Dual’ frequency mode the unit uses the narrow cone angle (200kHz) to display detailed bottom information, keeping “Dead Zones” to a minimum, and the wide cone angle (50kHz) for the large coverage area.

Fish returns from the wide and narrow beams appear differently on the display. The wide beam tends to show longer fish returns than the narrow beam, as shown in the diagram below.



Understanding the Graph

It is important to understand that the unit does not display a 3-D representation of the underwater environment. The unit can display multiple items at the same time, but cannot determine where each return originated – only when it was received.

Examples 1 and 2 provide a look at the underwater world from a top view, and illustrate how these views would be displayed on the graph. On both graphs it appears the fish and tree are side by side as shown in Example 1. However, when we look at Example 2, we see that the fish can be several feet from the tree. It is important to remember that the Fishfinder cannot determine where in the coverage area the tree or fish are, only that the returns were received at the indicated depths in the same time frame.

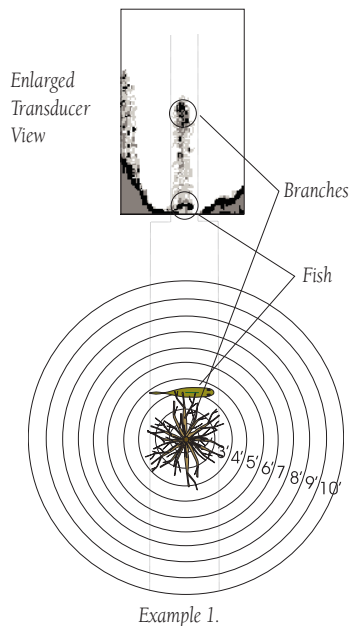

Example 1.

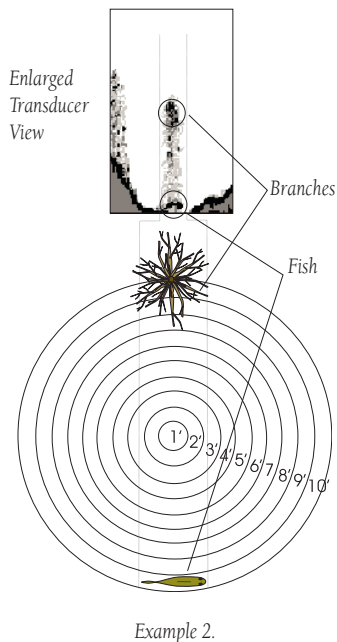

Example 2.

Understanding the Graph



Remember that the Fishfinder displays a 2-D picture of the underwater environment. The fish and tree could be located anywhere in the coverage area at that time.

Whiteline and Thermoclines



Whiteline can also help you to determine the type of bottom structure that is displayed on the graph. By determining the hardness of the structure, you can make a better informed decision on the type of structure.

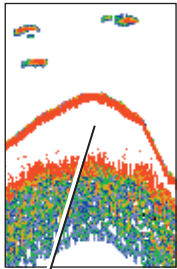

Structure is hard—
probably a rock or stump

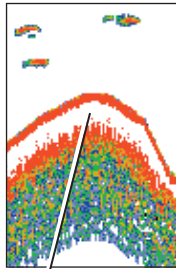

Structure is soft—
probably a mud pile

Whiteline

The Fishfinder 250/250C can help you to determine if the bottom is hard or soft. When the sonar soundwaves are reflected back by the bottom, a hard bottom returns a stronger signal than a soft bottom. A thin whiteline indicates a softer bottom while a thick whiteline indicates a harder bottom. Normally, the Fishfinder 250 uses a black line and the Fishfinder 250C uses a red line to show the point where water meets the bottom. This line follows the bottom contour, along with any significant objects lying on the bottom. The unit uses the whiteline function to make this bottom layer information easier to distinguish.

With the Fishfinder 250/250C, whiteline helps accentuate where strong signals are located, which make bottom type determination easier. The example to the right shows the bottom return with and without the whiteline activated. See page 14 for more information.

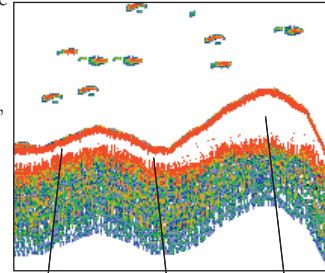

Whiteline Soft Bottom Hard Bottom

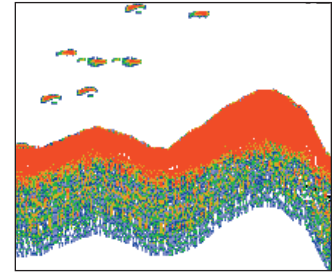

Whiteline Turned Off

Thermoclines

One of the unique features offered by Garmin is See-Thru® technology. See-Thru® technology allows the Fishfinder 250/250C to “see” through thermoclines and helps locate fish where they live -- and fish love thermoclines. A rough definition of a thermocline is a break in water where the water temperature changes faster than in the water above it. Thermoclines give weak returns and are shown as the weakest colors/shades (see pg. 11).

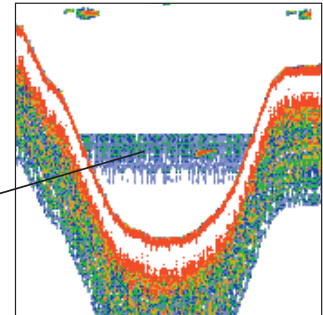

Thermocline

Specifications, Cleaning and Storage

Physical Specifications

Size:	6.1" W x 4.9" H x 2.9" D (15.5 cm x 12.5 cm x 7.4 cm)
Weight:	1.1 lbs. (0.5 kg)
Display:	(Fishfinder 250) 4.5" diagonal (11.4 cm), 3.2" W x 3.2" H (8.1 cm x 8.1 cm) high-contrast 10-level grayscale FSTN display with adjustable brightness (320 x 320 pixels) (Fishfinder 250C) 4.5" diagonal (11.4 cm), 3.2" W x 3.2" H (8.1 cm x 8.1 cm) high-contrast, 16-color CSTN display with adjustable brightness (320 x 320 pixels)
Case:	Fully gasketed, high-impact plastic alloy, waterproof to IEC 60529 IPX7 standards
Temp. Range:	5°F to 130°F (-15°C to 55°C)

Power

Source:	10-35 volts DC
Usage:	17 watts max. at 10 volts DC; 15 watts at 13.8 volts DC nominal
Fuse:	AGC/3AG - 2.0 Amp

Sonar

Power:	Dual frequency: 500 watts (RMS); 4000 watts (peak to peak) Single frequency: 400 watts (RMS); 3200 watts (peak to peak)
Frequency:	50/200 kHz
Depth:	1500 foot max depth (Depth capacity is dependent on water salinity, bottom type and other water conditions.)

Cleaning and Storage

The Fishfinder 250/250C is constructed of high quality materials and does not require user maintenance other than cleaning. Clean the unit using a cloth dampened with a mild detergent solution and then wipe dry. Avoid chemical cleaners and solvents that may damage plastic components.

Do not store the Fishfinder 250/250C where prolonged exposure to temperature extremes may occur (such as in the trunk of a car) as permanent damage may result. Unit settings will be retained in the unit's memory without the need for external power.

Messages and Alarms

The Fishfinder 250/250C uses an on-screen pop-up message system to alert you to unit operating characteristics. Press the **ENTER** key to acknowledge the message.

Battery Alarm — Battery voltage has fallen below the value entered in the Battery Alarm setup.

Battery Voltage High— Input voltage too high, unit will shut off. You must lower input voltage.

Boat is not Moving Fast Enough to Calibrate — Boat is not moving fast enough for the speed wheel to provide a valid speed.

Can't Send Waypoint — Unit was unable to transmit the waypoint via the NMEA WPL sentence. Check wiring.

Can't Read Voltages That High Limited To Top Of Range — Voltage value in the Battery Alarm setup is higher than the unit can read.

Can't Read Voltages That Low Limited To Bottom Of Range — Voltage value in the Battery Alarm setup is lower than the voltage where the unit automatically turns off.

Deep Water Alarm — Deep Water Alarm depth has been reached.

Drift Alarm — Depth has changed by the amount entered in the Drift Alarm setup.

Fish Alarm — Displays icon and sounds beep (if enabled) when a fish is detected. (This alarm does not display a message banner.)

Running Simulator — Unit is in Simulator Mode. This message will reappear after 2 minutes of inactivity. (If the unit does not detect a transducer attached, it will automatically enter Simulator Mode.)

Shallow Water Alarm — Shallow Water Alarm depth has been reached.

Sonar Failed Unit Needs Repair — Internal problem with unit. Contact your dealer or Garmin Product Support to have the unit serviced.

Timer Alarm — Timer Alarm value has counted down to 00:00:00.

Transducer Disconnected Sonar Turned Off — No transducer attached, bad cable/transducer or transducer cable was disconnected. If the transducer cable is removed while the unit is on, reconnect and cycle power.

Water Speed Sensor is not Working — Speed sensor is not detected. Check Connections.

Water Temperature Alarm — Water Temperature Alarm setting has reached value above, below, inside, or outside of specified value(s).

Index

A

Accessories iv-v
 ADJ/MENU Key 10
 Adjustment Menu 12
 Adjustment Menu Options 12
 Advanced Data Fields 17
 Advanced Display 17
 Alarms 19, 28
 Alarms Tab 19
 ARROW Keys 10
 Automatic Scroll Speed 21

B

Background Color 17
 Backlight 10
 Basic display 17
 Battery Alarm 19
 Beeper 20
 Bottom Lock 13
 Bottom Split 13

C

Calibrate Water Speed 21-22
 Cleaning 27
 Color, Background 17
 Color Bar 13, 17
 Contrast 10
 Custom Range 16

D

Data Fields 11, 17

Date 22
 Daylight Savings Time 22
 Deep Water Alarm 19
 Defaults 14, 20
 Depth 11-12, 15-17, 20
 Depth Line 14
 Depth Number 17, 21
 Depth Units 20
 Display Mode 20
 Distance Units 20
 Drift Alarm 19

E

ENTER Key 10

F

Factory Settings 20
 Fish Alarm 19
 Fish Symbols 11, 16
 Flasher 11, 17
 Frequency 14
 Fuse 5, 27

G

Gain 13
 Graph 25
 Graph Tab 16

H

Heading 21

I

Installation 1-9
 Interfacing 5-6

K

Keel Offset 21
 Keypad Usage 10

L

Language Selection 20
 Log and Graph Scale 18
 Log Duration 18

M

Main Menu 16-22
 Messages 28

N

NMEA 5-6, 15, 20-22
 NMEA Setup 20
 Noise Reject 14
 Number Size 17

Index

P

Packing List iv
Pointer 10, 12, 15
Position Format 20
POWER/BACKLIGHT key 9-10
Power Up 9
Preface i

R

Range 12
Registration i
Reset Odometer 20
Reset Scale 18

S

Scale 16
Scroll 14-15
Scroll Speed 21
Serial Number ii
Setting an Alarm 19
Shallow Water Alarm 19
Simulator 20

30

Size Split 14
Software License Agreement iii
Software Version 20
Sonar, Understanding 23-26
Sonar Page 11
Span 13
Specifications 27
Speed Units 20
Split Screen 13-14
Storage 27
System Tab 20

T

Table of Contents vi
Target Level 13
Temperature 17-18
Temperature Graph 17
Temperature Tab 18
Temperature Units 20
Testing the Installation 9
Thermoclines 26
Time 22
Timer 19
Time Duration 18
Time Format 22
Time Tab 22
Time Zone 22
Tools Tab 17
Transducer v, 7-9, 14, 23-24
Transducer Type 21

U

Understanding Sonar 23-26
Understanding the Graph 25
Underwater Waypoints 15
Units Tab 20

V

View 13

W

Warranty ii
Water Speed 17, 21
Water Temperature 17, 26
Water Temperature Alarm 19
Water Type 21
Waypoints 15
Whiteline 14, 26
Wiring 5, 6

Z

Zoom 11-13

For the latest free software updates (excluding map data) throughout the life of your Garmin products, visit the Garmin web site at www.garmin.com.



© Copyright 2004 Garmin Ltd. or its subsidiaries

Garmin International, Inc.
1200 East 151st Street, Olathe, Kansas 66062, U.S.A.

Garmin (Europe) Ltd.
Unit 5, The Quadrangle, Abbey Park Industrial Estate, Romsey, SO51 9DL, U.K.

Garmin Corporation
No. 68, Jangshu 2nd Road, Shijr, Taipei County, Taiwan

www.garmin.com

Part Number 190-00328-00 Rev. A

Free Manuals Download Website

<http://myh66.com>

<http://usermanuals.us>

<http://www.somanuals.com>

<http://www.4manuals.cc>

<http://www.manual-lib.com>

<http://www.404manual.com>

<http://www.luxmanual.com>

<http://aubethermostatmanual.com>

Golf course search by state

<http://golfingnear.com>

Email search by domain

<http://emailbydomain.com>

Auto manuals search

<http://auto.somanuals.com>

TV manuals search

<http://tv.somanuals.com>