

EVA

EVA Series User Manual

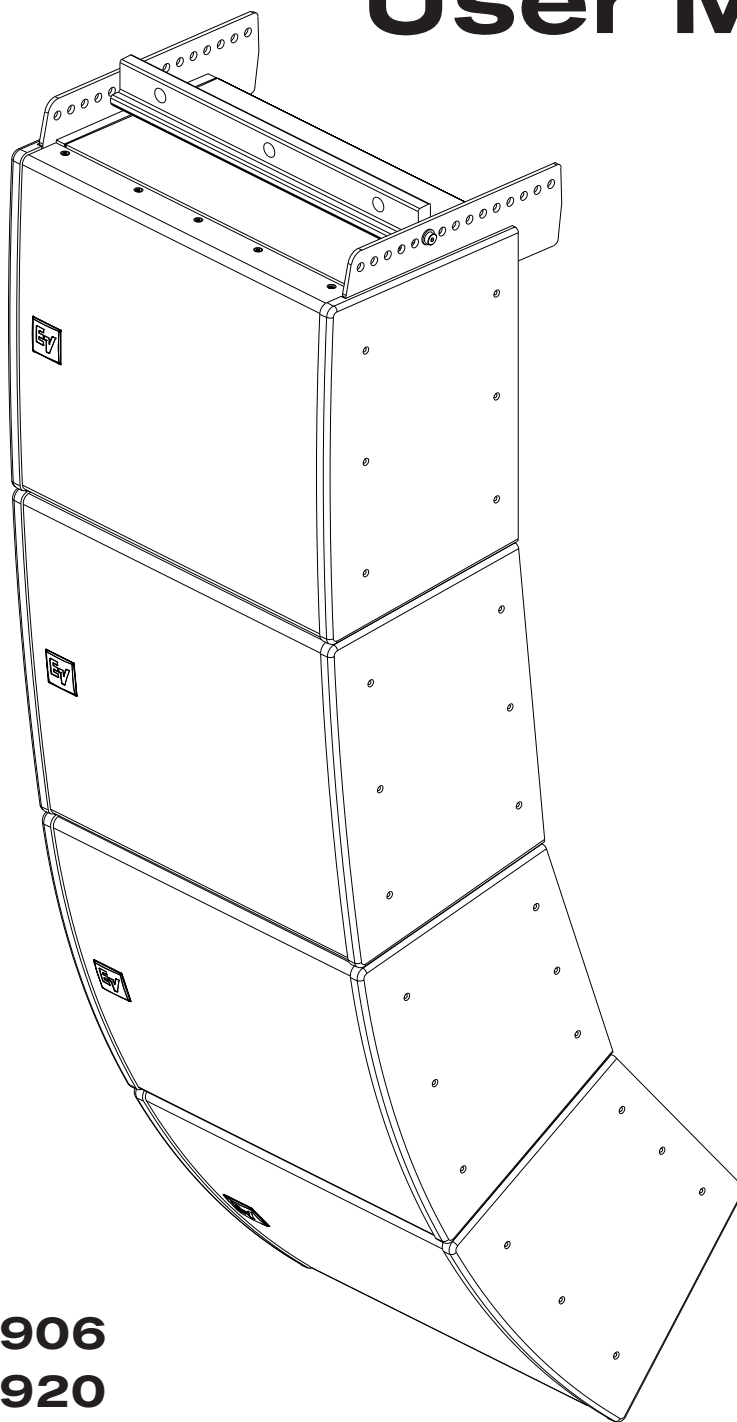

EVA-2082S/906
EVA-2082S/920
EVA-2082S/126
EVA-2082S/1220

Live For Sound
www.electrovoice.com





Table of Contents

Rigging-Safety Warning.....	3
1.0 Introduction.....	4
2.0 Tool List	7
3.0 Designing an EVA Array	7
3.1 Applications for which EVA Arrays are Most Appropriate	7
3.2 Typical Number of Arrays.....	7
3.3 Determining EVA Array Configuration with EVADA™ (EVA Design Assistant) Software.....	8
3.4 Other Design Examples	14
3.41 Dealing with the Relatively High Low-Frequency Variation of Short Arrays.....	14
3.42 A Five-Module Array Example.....	15
3.43 An Eight-Module Array Example	16
4.0 Preparing EVA Modules for Installation.....	17
4.1 Recommended Preflight Procedures	17
4.2 Module Configuration.....	17
5.0 EVA Rigging System.....	20
5.1 Overview of the EVA Flying System.....	20
5.2 Deciding which Grid Configuration to Use with an EVA Array.....	21
5.21 Standard Grid with or without Second Spreader Bar	21
5.22 Extended Grid with or without Second Spreader Bar	22
5.23 Use of Two Standard Grids.....	23
5.3 Assembling and Flying an EVA Array.....	24
6.0 Rigging-Strength Ratings and Safety Factors.....	25
6.1 Working-Load Limit and Safety Factor Definitions.....	25
6.2 Structural-Rating Overview.....	26
6.3 Simplified Structural-Rating Guidelines.....	27
6.4 Electro-Voice Structural-Analysis Procedures	30
7.0 Rigging Inspection and Precautions	31
8.0 References.....	32
8.1 Rigging (Printed)	32
8.2 Mechanical Engineering (Printed)	32
8.3 Rigging (Websites).....	33
Notes	34



Rigging-Safety Warning

This document details general rigging practices appropriate to the entertainment industry, as they would apply to the rigging of Electro-Voice EVA loudspeaker systems. It is intended to familiarize the reader with standard rigging hardware and techniques for suspending EVA loudspeaker systems overhead. Only persons with the knowledge of proper hardware and safe rigging techniques should attempt to suspend any sound systems overhead. Prior to suspending any Electro-Voice EVA loudspeaker systems overhead, it is essential that the user be familiar with the strength ratings, rigging techniques and special safety considerations outlined in this manual. The rigging techniques and practices recommended in this manual are, of necessity, in general terms to accommodate the many variations in loudspeaker arrays and rigging configurations. **As such, the user is expressly responsible for the safety of all specific EVA loudspeaker array designs and rigging configurations as implemented in practice.**

All the general rigging material contained in this manual is based on the best available engineering information concerning materials and practices, as commonly recognized in the United States, and is believed to be accurate at the time of original printing. As such, the information may not be directly applicable in other countries. Furthermore, the regulations and requirements governing rigging hardware and practices may be superseded by local regulations. It is the responsibility of the user to ensure that any Electro-Voice loudspeaker system is suspended overhead in accordance with all current federal, state and local regulations.

All specific material concerning the strength ratings, rigging techniques and safety considerations for the EVA loudspeaker systems is based on the best available engineering information concerning the use and limitations of the products. Electro-Voice continually engages in testing, research and development of its loudspeaker products. As a result, the specifications are subject to change without notice. It is the responsibility of the user to ensure that any Electro-Voice loudspeaker system is suspended overhead in accordance with the strength ratings, rigging techniques and safety considerations given in this document and any manual update notices. All non-Electro-Voice associated hardware items necessary to rig a complete EVA loudspeaker array (chain hoists, building or tower supports and miscellaneous mechanical components) are the responsibility of others.

Electro-Voice
December 2008

1.0 Introduction

The Electro-Voice® EVA (Expandable Vertical Array) loudspeaker systems or line-array modules represent an important step in line-array technology for small- and medium-scale fixed-installation sound reinforcement. The four models are designed to significantly simplify the physical assembly of a line array. Also, arrays of EVA modules are designed to be powered from one amplifier channel, the necessary crossover and EQ functions accomplished with sophisticated passive networks. The individual loudspeaker drivers, Hydra™ plane-wave generators, acoustic waveguides, enclosures and rigging hardware were all designed specifically for the EVA product line to not only achieve the highest acoustic output with the highest fidelity but also produce a precise wavefront from each element to achieve state-of-the-art line-array performance. A brief description of the product line is included below. The EVA modules are shown in Figure 1 with key dimensions and features.

Although the EVA modules shown in Figure 1 are not physically symmetrical, their acoustic polar responses are substantially symmetrical. Thus, stereo left and right arrays or left-center-right arrays may be constructed with the modules in their normal right-side-up orientation as shown in Figure 1. However, should the user desire, the module attachment points are such that mirror-image left-right arrays can be made by constructing one array with its modules turned upside down with respect to the views of Figure 1.

Each EVA module contains two separate, vertically stacked line-array elements.

EVA-2082S/906: two-way, LF/HF line-array module with a 90° horizontal x 6° vertical coverage pattern (for long throws) and passive crossover/HF-shading/EQ network. The enclosure is trapezoidal in the vertical plane with a 6° total included angle. The two line-array elements contained in the module are vertically splayed by 3°.

EVA-2082S/920: two-way, LF/HF line-array module with a 90° horizontal x 20° vertical coverage pattern (for short throws) and passive crossover/HF-shading/EQ network. The enclosure is trapezoidal in the vertical plane with a 20° total included angle. The two line-array elements contained in the module are vertically splayed by 10°.

EVA-2082S/126: two-way, LF/HF line-array module with a 120° horizontal x 6° vertical coverage pattern (for long throws) and passive crossover/HF-shading/EQ network. The enclosure is trapezoidal in the vertical plane with a 6° total included angle. The two line-array elements contained in the module are vertically splayed by 3°.

EVA-2082S/1220: two-way, LF/HF line-array module with a 120° horizontal x 20° vertical coverage pattern (for short throws) and passive crossover/HF-shading/EQ network. The enclosure is trapezoidal in the vertical plane with a 20° total included angle. The two line-array elements contained in the module are vertically splayed by 10°.

EVA-AM: this optional attenuation module mounts on the inside of an EVA input panel, and attenuates the entire module by 3, 6 or 9 dB. The nominal impedance of an EVA module is 16 ohms. Up to six paralleled EVA modules can be driven from a single amplifier channel capable of driving a 2.7-ohm nominal impedance (16 ohms ÷ 6 modules = 2.7 ohms).



1.0 Introduction (cont')

Up to eight paralleled modules can be driven from a single amplifier channel capable of driving a 2.3-ohm nominal impedance if at least two of the modules have the optional EVA-AM attenuation modules installed.

All EVA modules contain two vertically stacked EVS2008 8-inch (203 mm) LF drivers and two pairs of DH2005 1.25-inch-diaphragm (32 mm) HF drivers. Each driver pair is mounted on a Hydra™ plane-wave generator, the two of which are vertically stacked. The internal shading network can attenuate either the upper or lower HF driver pair by 3 dB.

The standard EVA indoor versions are finished in tough EVCoat™. In addition, all EVA modules are available in two levels of weather resistance. The FG versions, e.g., EVA-2082/906-FGB, are designed for full weather exposure and feature a fiberglass-finished enclosure, stainless-steel hydrophobic grille and the CDG dual-gland-nut input-panel cover. The PI versions, e.g., EVA-2082S/906-PI, are rated for indirect outdoor exposure only in protected areas, such as under a roof overhang, and feature a stainless-steel hydrophobic grille and CDG dual-gland-nut input-panel cover on an enclosure finished in standard EVCoat. External fasteners on all EVA systems are stainless steel.

All EVA modules are available in black or white and are supplied with the hardware necessary to fasten one module to another and two cosmetic end caps, which give the finished array a smooth and uncluttered appearance. (The end caps on FG fiberglass versions are also finished in fiberglass.) Black is indicated by BLK or B at the very end of the complete model number and white is indicated by WHT or W at the very end of the complete model number, e.g., EVA-2082S/906-BLK and EVA-2082S/906-PIB.

EVA-SG-BLK and EVA-SG-WHT: standard grids for typical down angles with small arrays, or top and bottom suspension for extreme down angles in large arrays.

EVA-EG-BLK and EVA-EG-WHT: extended grids for extreme down angles in small to medium arrays and typical down angles in large arrays.

The two different grid options (EVA-SG and EVA-EG) are sold separately. **Consult EVADA software for proper grid selection.**

EVA-GXB-BLK and EVA-GXB-WHT: optional second spreader bars for the standard and extended grids, to be used when two-point front-to-back hangs are desired. Note: the need to maintain sufficient pressure on the forward rigging point will limit the amount of down angle available with the standard EVA-GRID in this configuration.

CDG: optional dual-gland-nut input-panel cover to protect the input connections from water. Note that this cover is supplied with the weather-resistant versions of EVA modules.

CSG: optional single-gland-nut input-panel cover to protect the input connections from water.

CDNL4: optional input-panel cover equipped with dual Neutrik Speakon® NL4M connectors, providing a quick-disconnect alternative to the standard Phoenix screw-terminal input connectors.

1.0 Introduction (cont')

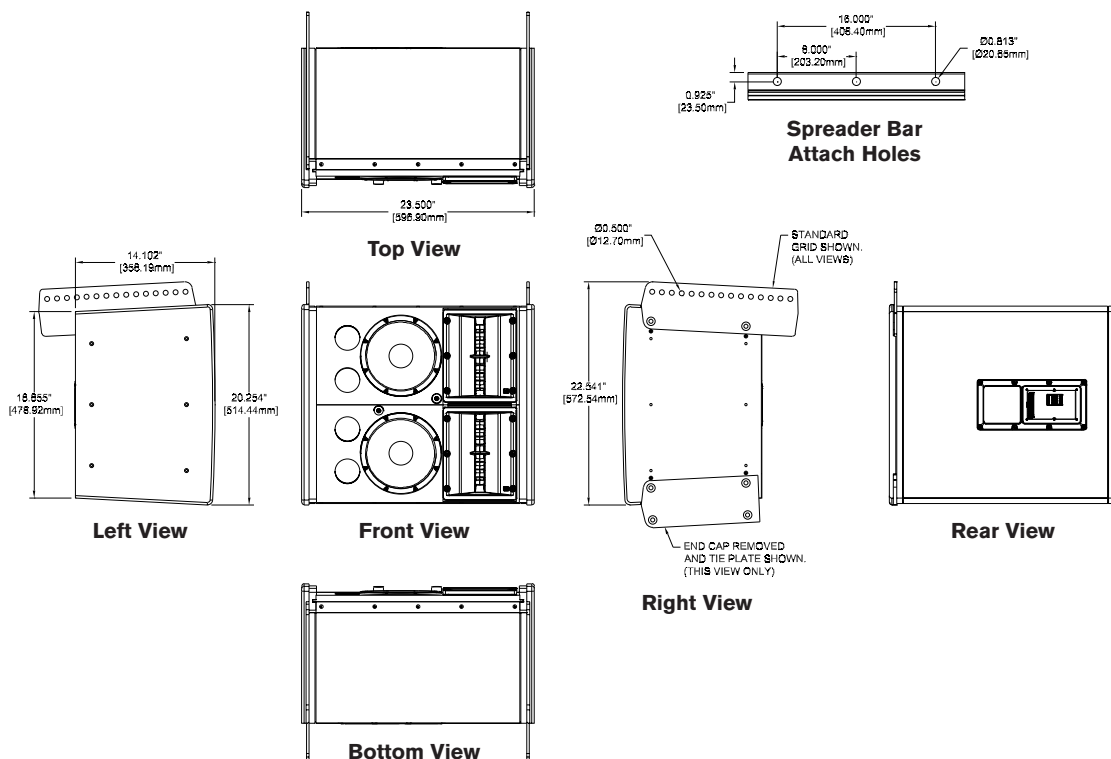

Figure 1a:
EVA-2082S/906 or EVA-2082S/126 dimensioned views

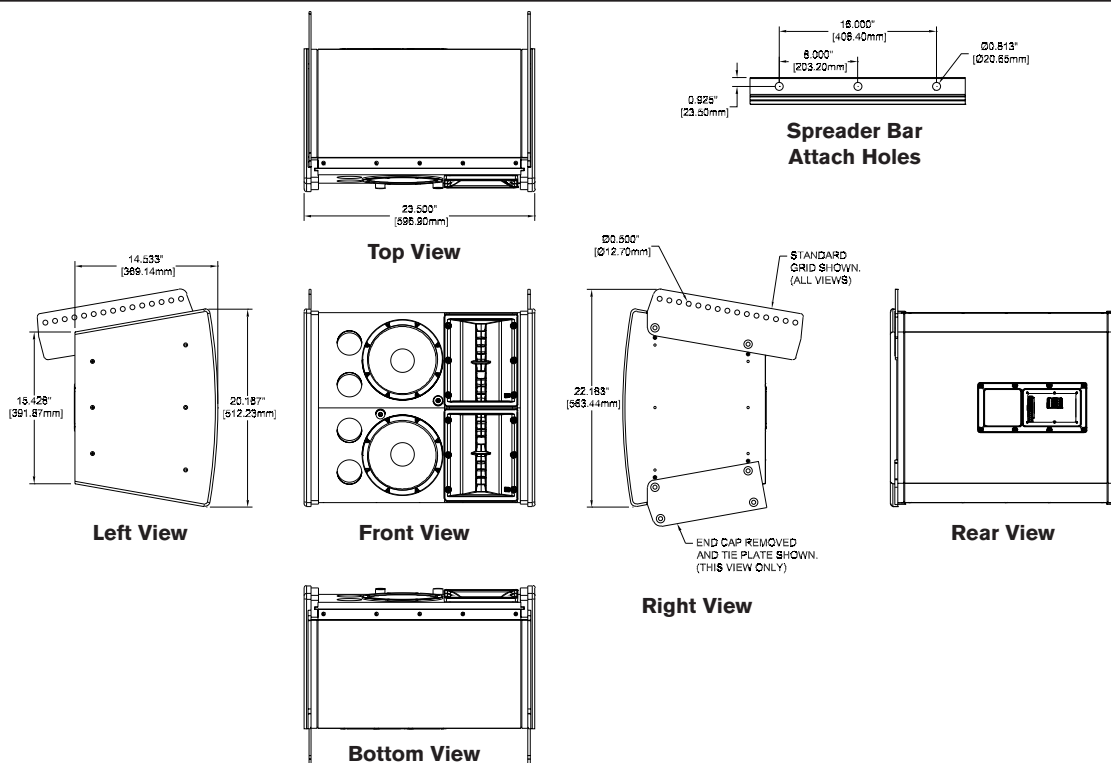

Figure 1b:
EVA-2082S/920 or EVA-2082S/1220 dimensioned views

2.0 Tool List

Listed below are the tools required to assemble an EVA array:

1. Phillips #2 screwdriver (for attaching cosmetic end panels).
2. 6-mm Allen (hex) wrench (for attaching tie plates and assembling grids).
3. 3/16-inch flat-blade screwdriver (for attaching signal wires to input-panel connectors).

3.0 Designing an EVA Array

3.1 Applications for Which EVA Arrays Are Most Appropriate

The total included vertical angles of the EVA modules in side view (6° for long throw and 20° for short throw) were determined after making many array simulations with the EVA Design Assistant (EVADA™) software (described in some detail below). Optimum maximum throw distance for uniform front-to-back coverage is 100 ft \pm 25 ft.

In side view, a quick rule of thumb for aiming a three- or four-box array in a venue with a flat floor is to have a line running through the intersection of the top two modules intersect the head of the person in the last row. This situation is shown in Figure 2.

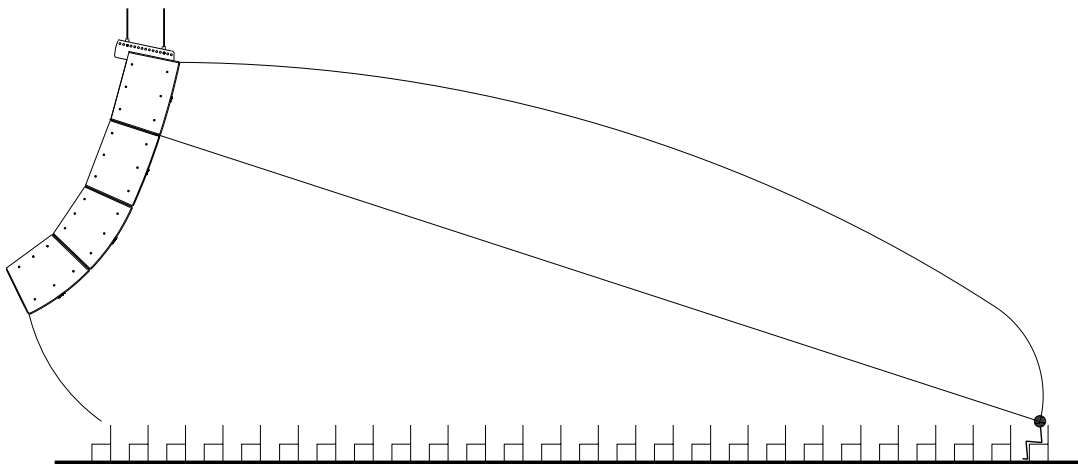

Figure 2:
Rule-of-thumb for aiming three- and four-module EVA arrays

3.2 Typical Number of Arrays

Line-array systems usually consist of vertical columns of multiple independent line-array elements. The most common implementation is probably a stereo sound reinforcement system with two columns (left and right). Additional columns are sometimes added to cover different seating sections of a venue, e.g., seating areas that wrap around the side or back of a stage. An additional column is also used in left-center-right configurations, with the center channel for speech. In some venues, where stereo is not desired, good coverage can be obtained with a single array. A variation of such a monaural system is the exploded array, where two or more widely spaced (on the order of 10 ft or more) arrays are used to provide the horizontal coverage required. Also, a large number of arrays may be used in distributed systems, such as in an arena.

3.0 Designing an EVA Array (cont')

3.3 Determining EVA Array Configuration with EVADA™ (EVA Design Assistant) Software

EVADA™ is Excel-spreadsheet-based software for determining optimum array configurations for a given venue and trim heights. The latest version of EVADA is downloadable from the Electro-Voice Web site (www.electrovoice.com).

Briefly, one models the room along the horizontal aiming axis of the array, then builds the array of long-and/or short-throw modules that produces the most even coverage front to back. (As described above, EVA modules come in two horizontal coverage angles, 90° and 120°. Following industry convention, these angles are defined where output is 6 dB down from the maximum [usually on axis] output. Chose the horizontal angle that provides good coverage of the audience in plan view but minimizes energy directed on reflective wall surfaces, which energizes the room and lowers the intelligibility of the sound system.)

EVADA displays coverage in three frequency bands. The default bandwidth is one-third octave. The default frequencies are 500 Hz, 3,000 Hz and 8,000 Hz. 3,000 Hz is very important for voice intelligibility. 8,000 Hz is important for “sparkle.” 500 Hz (and below) is important for maintaining a good spectral balance throughout the venue. Longer arrays provide low-frequency uniformity closer to the mid- and high-frequency performance of the array. These effects can be easily seen in EVADA. In addition, the frequencies and bandwidths can be modified by the designer.

EVADA includes an extensive help file but the following overview will provide a good introduction.

Figure 3 shows the Venue tab of the EVADA spreadsheet, where the room information is entered, including dimensions, head height, stage specs (optional) and the so-called “acoustic reference point.” This is the point in the venue where EVADA makes its sound-pressure level (SPL) calculations. The acoustic-reference point is typically the mixing position. If uncertain, enter a position in the middle of the main coverage area.

VENUE		MEASUREMENTS	
BALCONIES	LOCATION	UNITS	MODE
NONE	INDOORS	English	STAGE
ONE	OUTDOORS		RUN & RISE
TWO			FLOOR

POINTS	Run, Feet	Rise, Feet	Stage Specs, Feet	
A	10.0	0.0	Depth	Height
B	50.0	0.0	0.0	0.0
C	80.0	0.0	Head Height, Feet	
			4.0	
			Acoustic Ref Pt, Feet	
			Downstage	Height
			70.0	4.5

MAH FLOOR	FIRST BALCONY	SECOND BALCONY	VENUE REFERENCE POINT
<input type="radio"/> First floor seat <input type="radio"/> Last floor seat <input type="radio"/> Last seat on riser			<input type="radio"/> Venue measurements from here

Figure 3:
EVADA™ Venue tab, where room information is entered

3.0 Designing an EVA Array (cont')

Figure 4 shows the EVADA Main tab, where the array is built and its performance evaluated in the three frequency bands mentioned above. This tab is full of information and things to enter:

1. In the top middle of the view is where the number of suspension points (one or two, front to back), array trim height and distance downstage from front of rig are chosen. Regarding trim height, be sure to allow for the height of the lifting mechanism(s) and attachment points.
2. At the top right of the view is where the three frequency bands and their bandwidths are shown. The default bandwidth is 0.33 octave and the default frequencies are 3,000 Hz, 500 Hz and 8,000 Hz. These can be changed by the user.
3. The Loudspeaker Stack column and table at the upper left allows the user to (1) pick the standard or extended grid (click on the default grid cell to access a selection menu), (2) adjust the grid tilt angle, and (3) pick any of the four EVA modules up to eight in number. The HF Attenuator column contains cells which show the effect of the internal 3-dB high-frequency attenuator (high-frequency shading): no attenuation or attenuation of either the upper or lower high-frequency driver pair. The Optional Attenuator column contains cells which show the effect of the optional EVA-AM attenuator module: 0 dB (not installed), or 3 dB, 6 dB or 9 dB (installed).
4. Once the elements of items 1 and 3 are complete, clicking on the yellow Update Prediction button will calculate array performance. This button appears in the Main Cluster geometry view (one is shown in Figure 9). The module vertical aiming angles are also displayed, with a different colored, slightly splayed line pair for each module (as noted in Section 1.0, there are two line-array elements in each EVA module, vertically splayed by 3° or 10°, depending on model). If the Show Polars box is checked under Options, the vertical polar responses of the array are also shown in this area, in the three frequency bands and bandwidths chosen. The acoustic reference point described earlier is the small plus sign shown near the rear of the seating area (approximately on the lower yellow module-aiming line).
5. The most important predicted information is shown in the Main Cluster SPL graph below the Main Cluster Geometry view. This shows the predicted coverage uniformity front (left) to back (right) in dB, where 0 dB is the value shown in the upper right-hand corner of the Main Cluster SPL view. (In Figure 4, this value is 112 dB SPL.) Note that SPL prediction is a complex function of the array maximum output versus frequency, the spectral distribution and peak-to-average ratio of the program material, the dynamic peak capability of the power amplifiers, and room acoustics. However, the EVADA calculated SPL value has been found to be close to the peak indications, e.g., peak pointer readings, on a sound level meter with C or F (flat) weighting in its fast averaging mode under the following conditions: (1) typical broadband contemporary music program, (2) two arrays operating in a reverberant environment and (3) using the power amplifiers recommended in the engineering data sheets (available at www.electrovoice.com). (A one-array design would reduce the predicted SPL by 3 dB.)

3.0 Designing an EVA Array (cont')

Producing the most uniform front-to-back coverage is an iterative process. In general, it will be found that:

1. The top-most module will be aimed above the last-row heads. This may appear to aim array output at the back wall, which if reflective could produce audible delayed signals in the front of the room. However, reference to the 3,000- and 8,000-Hz vertical polar responses shows that maximum array output is aimed at the rear-most heads, not at the rear wall.
2. The lower modules will be attenuated. This is required because the lower modules are so much closer to the seats they cover than are the upper modules.

Coverage uniformity of ± 3 dB front to back is a good goal for mid and high frequencies. At 500 Hz and below, such uniformity may not be attainable, particularly for short arrays (see additional comments in Section 3.41).

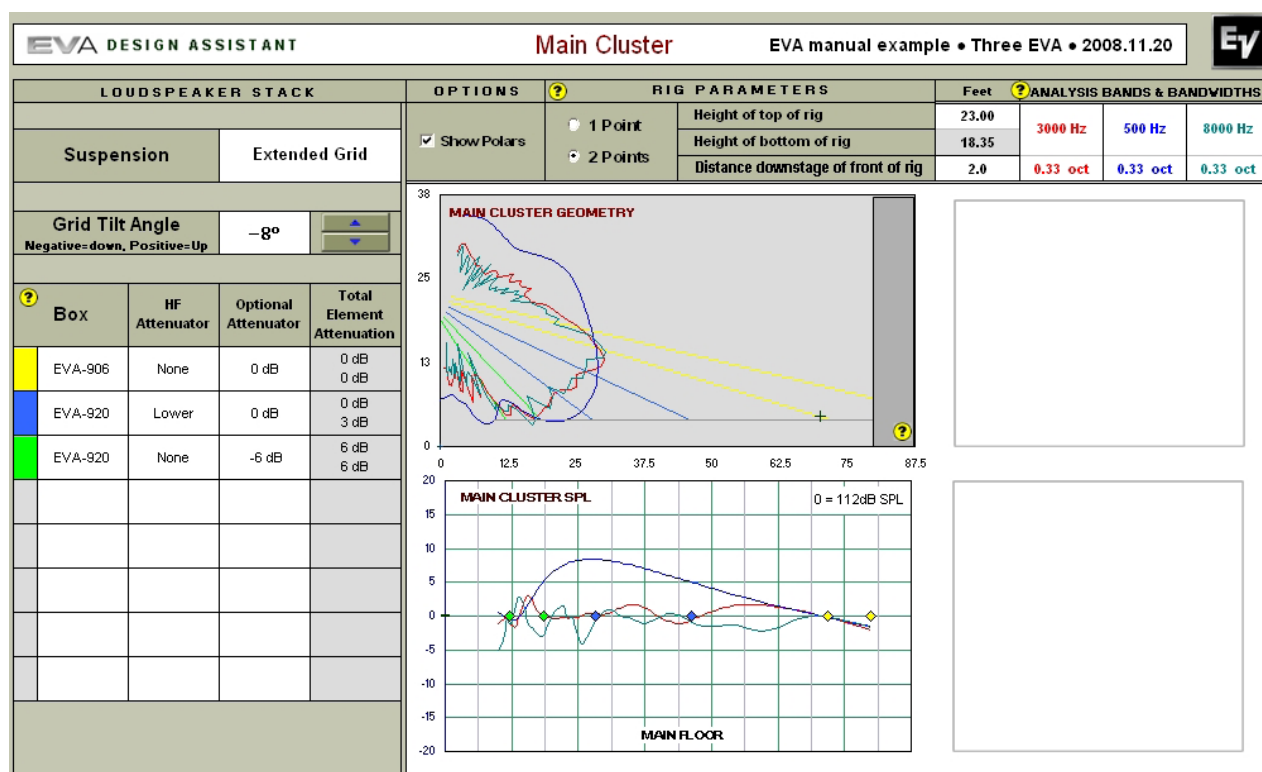

Figure 4:

EVADA™ Main tab, where the array is built and performance is displayed in three frequency bands

3.0 Designing an EVA Array (cont')

Figure 5 shows the Picture tab of the EVADA spreadsheet, with a side view of the array and its suspension. The array is drawn to scale, in feet or meters as selected in the Units tab on the Venue page (English or metric, respectively). The grid tilt angle may be adjusted in this tab. One- or two-point rigging can be selected. Diagnostic messages will appear in the Messages cell, as needed.

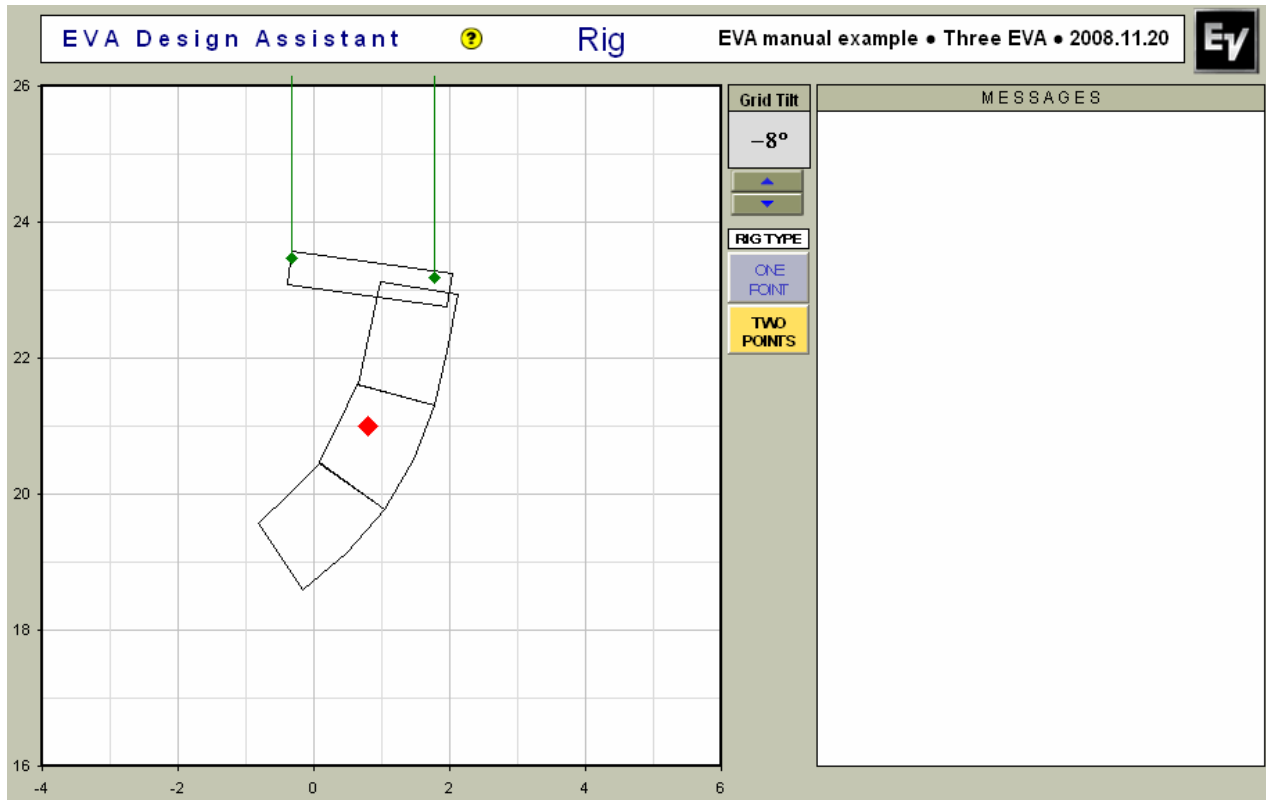

Figure 5:
EVADA™ Picture tab

3.0 Designing an EVA Array (cont')

Figure 6 shows the Report tab of the EVADA spreadsheet, showing such details as hang points (in this example, pinholes 18 and 0 on the extended grid), type of hang point (main or pullback), load (lb), modules in the array and their vertical aiming angles (note that the module inclination angle is the rear panel of the module).

EVA DESIGN ASSISTANT				EVA	
Rigging Specification					
VENUE	EVA manual example			REV	1
JOB	Three EVA			DATE	2008.11.20
DESIGNER	Jim Long				

RIGGING					
Fly Points				Two point hang	
Point No.	Type	Distance Upstage, ft	Load, lb	Pinhole	Note
1	Main point	0.37	128	18	
2	Main point	-1.74	131	0	
			260		

Grid Tilt: 8.0 degrees down
 Elevations above Floor: Rig top: 23.33 ft, bottom: 18.35 ft
 Height of rig: 4.98 ft
 Frontmost point of rig: 2.09 ft downstage
 Rearmost point of rig: 0.86 ft upstage

Loudspeakers					
Element No	Model	Box Inclination Angle (+ = up)	HF Attenuator	Optional Attenuator	Note
1	EVA-906	-12.5°	None	0 dB	
2	EVA-920	-25.5°	Lower	0 dB	
3	EVA-920	-45.5°	None	-6 dB	

Note: Box inclination angle is angle of EVA rear panel.

Figure 6:
 EVADA™ Report tab, with many physical array details

The Subwoofers tab allows the user to assemble subwoofer arrays and assess the inevitable multiple-source interference that occurs when two or more arrays are displaced horizontally. This is done by showing the horizontal polar response of subwoofer arrays at three frequencies. The default frequencies are 90, 60 and 40 Hz but can be changed. The option of changing the polarity of each subwoofer and inserting up to 9.9 ms of delay in any one group of subwoofers is available. These options may be found to smooth the interference patterns.

The Preferences tab allows the user to change the colors associated with each array element or module. Refer to the Preferences help file for details.

3.0 Designing an EVA Array (cont')

The Cable Loss tab allows the user to enter the combined impedance of an EVA array and the length and gauge (AWG) of the wire feeding it, in order to calculate the level lost (dB) in the cable feeding the array. See Figure 7.

EVA DESIGN ASSISTANT

Cable Loss Calculator ? EVA manual example • Three EVA • 2008.11.20

PARAMETERS (enter numbers here)

Loudspeaker Impedance	5.3	Ohms <small>(see note 1)</small>
Cable length	150.0	Feet
Cable gauge	8	(AWG) <small>(see note 2)</small>

RESULTS

Net power loss due to cable	0.6	dB
Effective damping factor	13.4	

Note 1: The impedance of an individual EVA loudspeaker box is 16 ohms. When multiple EVA boxes are wired in parallel, the impedance of the set is equal to 16 *divided by* the number of boxes. So 2 boxes = 8 ohms, 3 boxes = 5.3 ohms, 4 boxes = 4 ohms, and so on. Here is a diagram of three EVA boxes wired in parallel:

Note 2: The input terminals on EVA loudspeaker boxes will accept wire up to 10 AWG in size. To use loudspeaker cables with gauge larger than this, solder short 10 AWG adapters to the ends of the larger cable. Because the adapters are short, they will not introduce appreciable extra resistance.

Figure 7:
EVADA™ Cable Loss tab, calculates the dB level lost in speaker wiring as a function of the wire gauge (AWG) and length

The Notes tab is a place to enter comments on the particular design.

The Supported Products tab shows both the EVA main array products but also Electro-Voice subwoofers which are suitable for use with EVA arrays. These vary in maximum acoustic output ability and low-frequency cut-off frequency. The Electro-Voice Web site (www.electrovoice.com) has detailed information on the subwoofers listed.

3.0 Designing an EVA Array (cont')

3.4 Other Design Examples

3.41 Dealing with the Relatively High Low-Frequency Variation of Short Arrays

The example of Figure 4 is a three-module array addressing a flat floor from a trim height of 23 ft, with the first row 10 ft away from the array and the last row 80 ft away. This design opts for very uniform mid- and high-frequency coverage that hovers around the 0-dB line, with a variation that is well within the optimum ± 3 dB at 3,000 Hz (important for vocal intelligibility) and nearly as uniform (± 3.5 dB) at 8,000 Hz (the “sparkle” range). At 500 Hz, however, the uniformity is a non-optimum ± 4.5 dB. Instead of hovering around the 0-dB line, coverage has a distinct bias, rising from about 0 dB at the front to a high of +8 dB about 25% of the way back, then falling slowly back to 0 dB at the rear. This is a function of the relatively short, 4.7-ft three-module array. The variation at 100 Hz (not shown) is even greater (± 6 dB), and drops continuously from front to back. This means that if the sound is well balanced up front, it will be “thin” at the rear (although intelligibility and clarity will be fine).

Figure 8 shows the same array with a modification that provides more uniform “tracking” of the three frequencies. In general, this is achieved by attenuating the upper modules. For most of the venue, all three frequencies are within ± 3 dB of each other. While levels fall at the rear of the room, the falloff is very uniform with frequency. This provides a more uniform spectral balance front to back, which may be preferred to the performance shown in Figure 4.

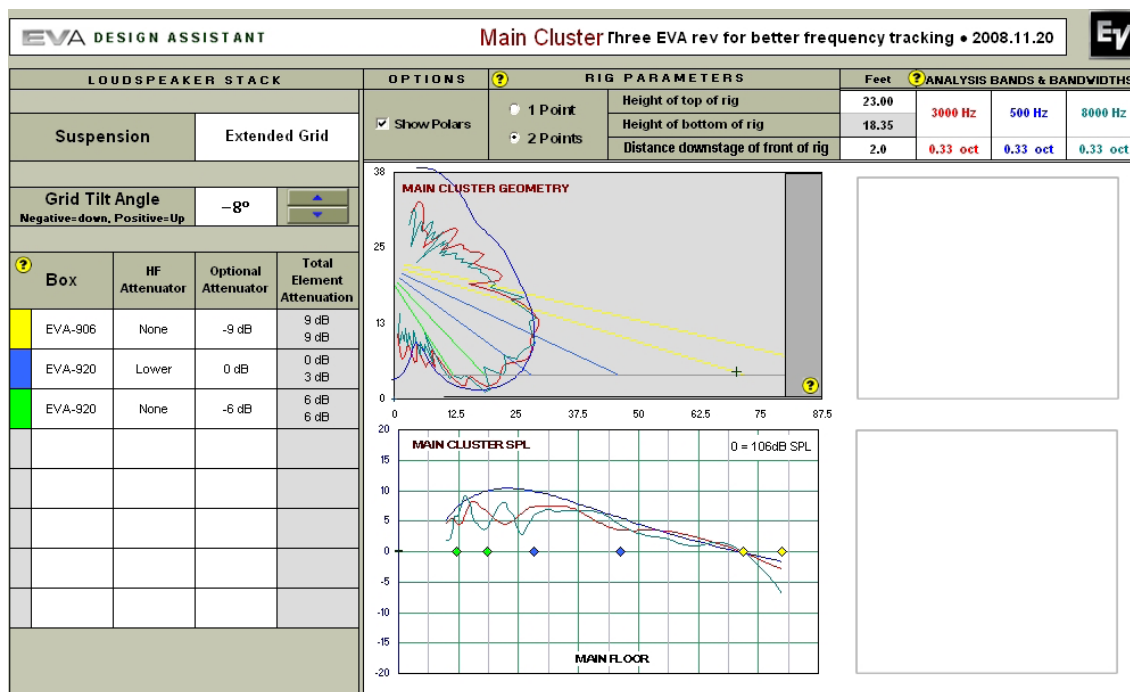

Figure 8:

A three-module EVA example of Figure 4, modified to improve the front-to-back “tracking” of all three predicted frequencies

3.0 Designing an EVA Array (cont')

3.42 A Five-Module Array Example

Figure 9 shows another, five-module array in an 80-ft-deep venue with the front row five ft from the array and whose floor begins to rise about halfway back. The three frequencies not only track very well but nearly all of the venue is within ± 3 dB front to back. This desirable situation is helped by not only the 3-dB attenuation of the top module but also by the array being longer than the three-module examples above (4.4 ft versus 7.3 ft).

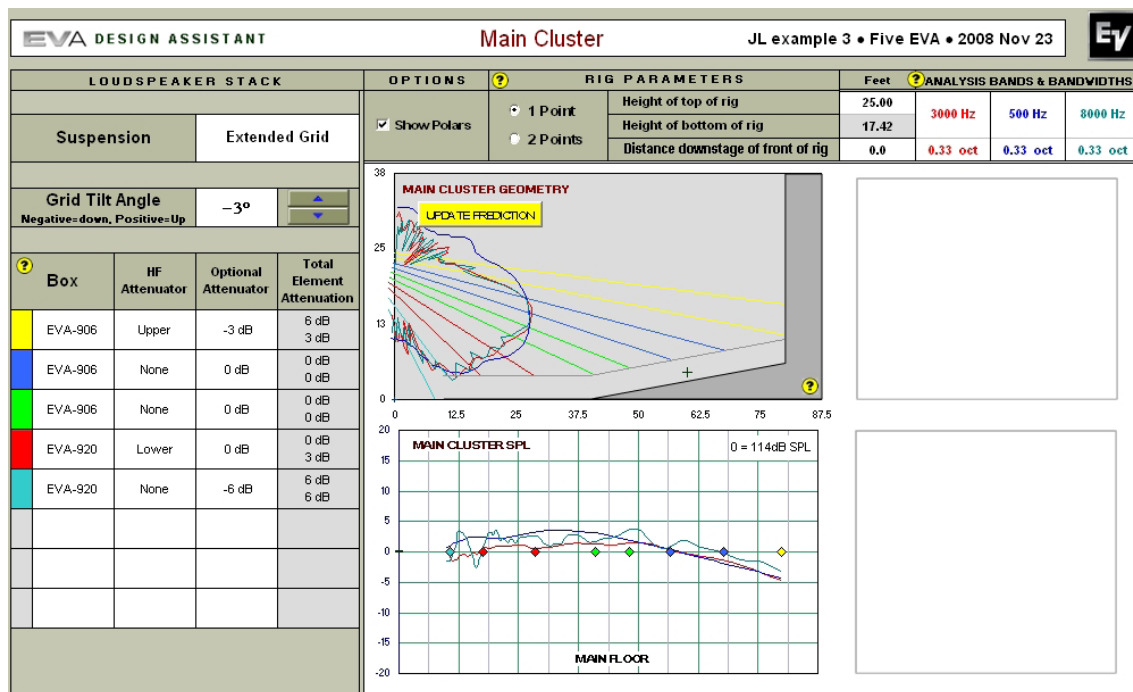

Figure 9:

A five-module EVA example whose three predicted frequencies not only track well front-to-back, but also fall mostly within the desired ± 3 dB

3.0 Designing an EVA Array (cont')

3.43 An Eight-Module Example

Figure 10 shows an eight-module array in a large theater with two balconies. Note that this array cannot be driven from one amplifier channel because only one of the modules uses the optional EVA-AM attenuation module. (An eight-module EVA array can be driven from an amplifier capable of driving a 2.3-ohm nominal impedance if two of the modules have attenuation modules installed. A solution is to use two amplifier channels, one for the top four modules and one for the bottom four. In order to preserve the predicted array coverage, be certain that the voltage gains of both channels are the same.)

Nearly all of the 100-ft-deep main floor is covered within the optimum ± 3 dB at all three predicted frequencies. The same uniformity applies to the first balcony (108 ft at the rear wall) although the average level drops by about 3 dB. The upper balcony (also 108 ft at its rear wall) shows a bit wider variation and less uniform tracking of the three predicted frequencies. However, the total variation in the upper balcony is still an acceptable ± 4 dB.

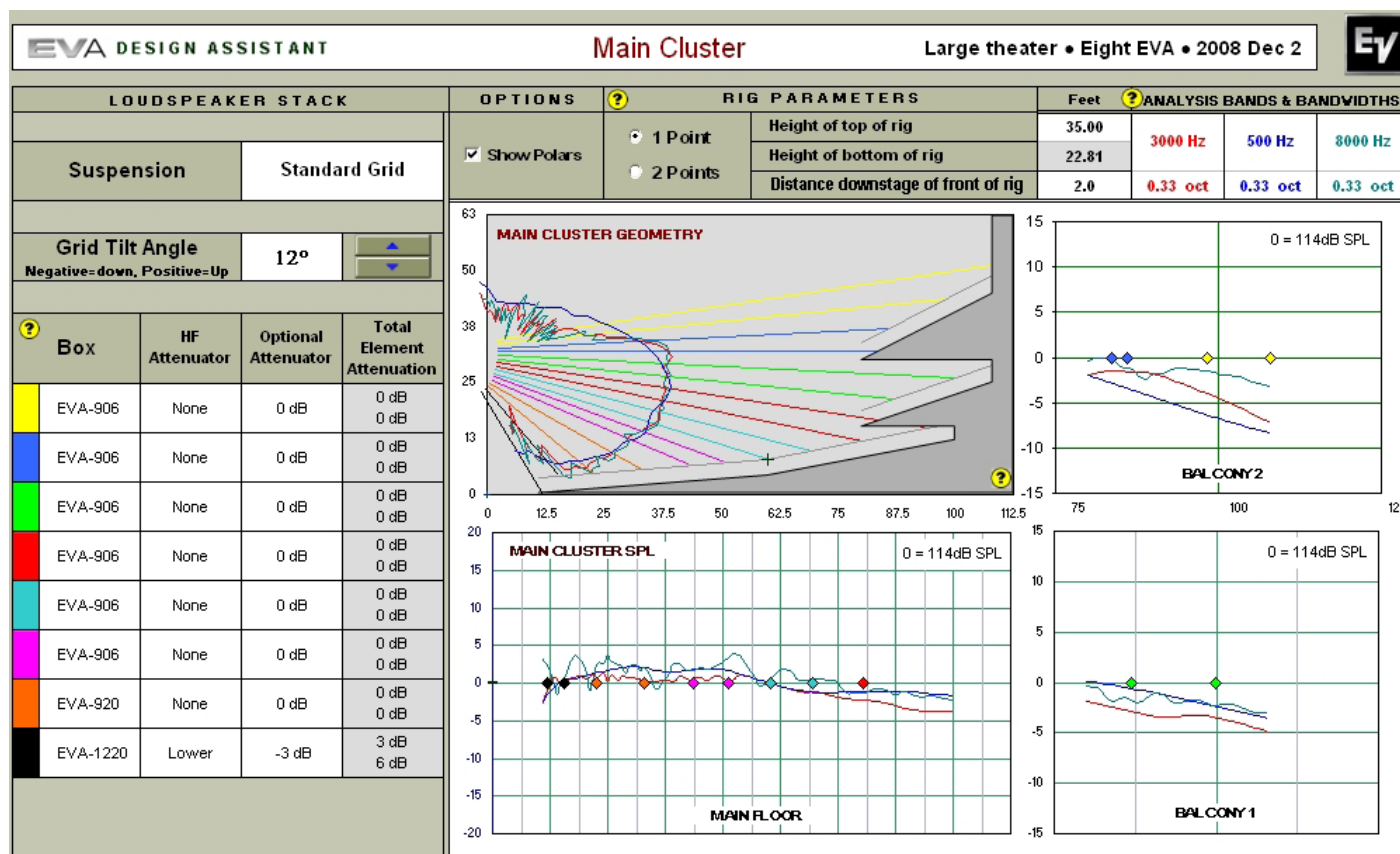

Figure 10:
A eight-module EVA example in a large theater with two balconies
(see text above for more details)

4.0 Preparing EVA Modules for Installation

4.1 Recommended Preflight Procedures

For any installed sound system, certain checks made at the installer's place of business can prevent expensive on-site delays. A short-list follows, and sets the stage for proper array performance:

1. Unpack all loudspeakers in the shop.
2. Check for proper model numbers.
3. Check the overall condition of the loudspeakers.
4. Check for continuity at the loudspeaker inputs.

It is a good idea, once on site and the loudspeakers are connected, to check again for continuity at the power-amplifier end.

4.2 Module Configuration

After the EVADA software has been used to design an appropriate array, the high-frequency (HF) shading or use of the optional attenuation modules should be noted. In this way, these settings and options can be configured on the systems as they are rigged together and suspended. (The shading adjustments and installation of attenuation modules can be completed at the installer's shop but then care must be taken to see that the EVA modules are properly identified to avoid misassembly of the array in the field.)

Figure 11 shows an EVA HF shading switch card. This card comes pre-inserted in the "Center = Both @ 0 dB" position, indicating no shading of either HF element.



Figure 11a:
EVA input panel as supplied,
with the high-frequency (HF)
shading switch card in its
central, 0 dB position



Figure 11b:
EVA input panel, with the
switch card inserted to shade
the lower HF element 3 dB



Figure 11c:
EVA input panel, with the
switch card inserted to shade
the upper HF element 3 dB

4.0 Preparing EVA Modules for Installation (cont')

To attenuate the top HF element, remove the switch card by drawing it toward you using the central finger hole. (The switch can also be removed with the end of a flat-blade screwdriver, by placing the blade end in the switch hole and using the adjacent edge of the input panel as a fulcrum. To facilitate this operation, there is a small recess in the edge of the input panel adjacent to the hole in switch card.) Reinsert the switch card one step higher to shade the upper HF element by 3 dB. Reinsert the switch card one step lower to shade the lower HF element.

Some array designs will also use one or more of the optional EVA-AM attenuation modules. These attach to the inside of the input-panel assembly using the following steps:

1. Remove the input-panel assembly by removing its eight holding screws with a Phillips #2 screwdriver. The cable assembly that connects the input-panel's green PC board to the crossover/equalizer network inside the EVA module is long enough to allow the input-panel assembly to rest on a flat surface close to the EVA module. If necessary, the crossover/equalizer cable can be temporarily disconnected. The removed input-panel assembly is shown in Figure 12.
2. Unplug and discard the 7-pin jumper-wire connector. The attenuation module's cable connector will replace this connector.
3. With the mounting straps on top, place the attenuation module into the pocket between the four bosses adjacent to the PC board and secure with the four screws (provided).
4. Plug the attenuation module's cable into the 7-position header on the PC board as shown in Figure 13.
5. Apply the supplied label to the input panel around the input connectors as shown on the EVA-AM Instruction Sheet.
6. Reinstall the input-panel assembly.
7. Connect a short piece of wire (supplied) from the "SELECT" terminal to the terminal marked -3, -6 or -9 dB, as determined by EVADA.

4.0 Preparing EVA Modules for Installation (cont')

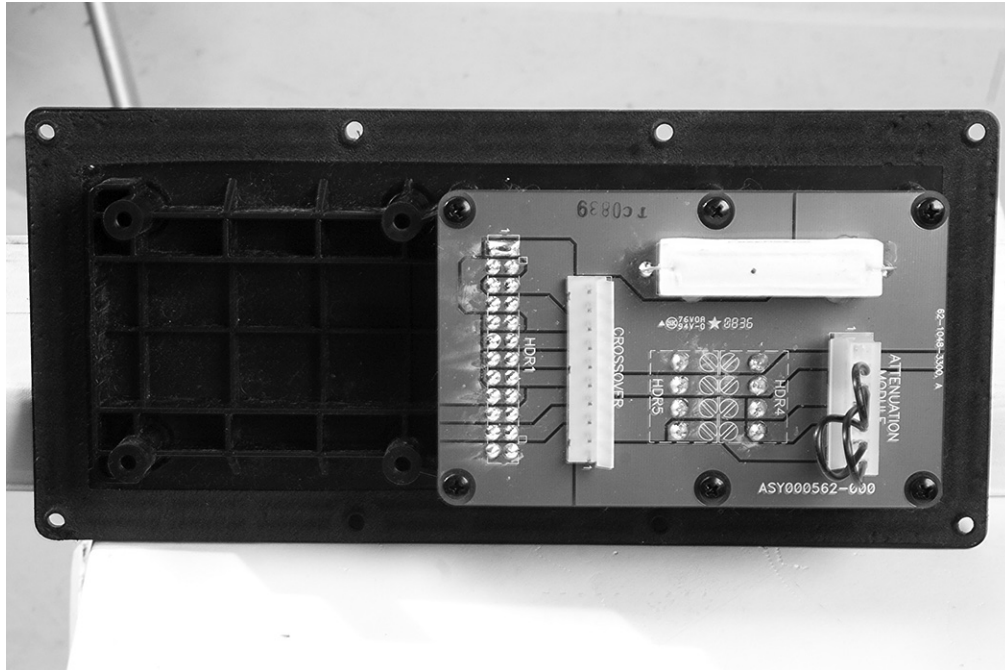

Figure 12:

EVA input panel removed, showing green PC board and the four bosses to which the optional EVA-AM attenuation module will be attached



Figure 13:

EVA input panel with EVA-AM installed showing connector plug-in

5.0 EVA Rigging System

5.1 Overview of the EVA Flying System

The external rigging parts supplied with each EVA line-array module attach to metal parts internal to each module, so that a finished array places no stress on the wooden enclosure parts. The rigging simplification inherent in the EVA modules is based on the final array being assembled in a fixed manner. The EVA enclosures are vertically trapezoidal—taller at the front than at the back. One module is fastened to another with the bottom of one in contact with the top of another. The vertical aiming angle between the two modules is fixed by their vertical draft angles. The draft angle is 3° for the EVA-2082S/906 and EVA-2082S/126 long-throw modules and 10° for the EVA-2082S/920 and EVA-2082S/1220 short-throw modules, producing 6°, 13° or 20° between any two modules, depending on which modules are attached together. (The specific selection of long- and short-throw modules and their arrangement is dependant on room geometry and trim height. These choices are facilitated by Electro-Voice’s EVA Design Assistant [EVADA™], software available on the EV Web site, www.electrovoice.com. See section 3.0 Designing an EVA Array above.) Each EVA module is attached to the module below it by the supplied pair of side-mounted tie plates. After the array is assembled, cosmetic end caps, one for each side of each module, are attached to the enclosure, hiding the structural tie plates and giving a smooth, attractive array appearance.

A basic array is shown in Figure 14, which illustrates the basic components that make up the EVA flying system.

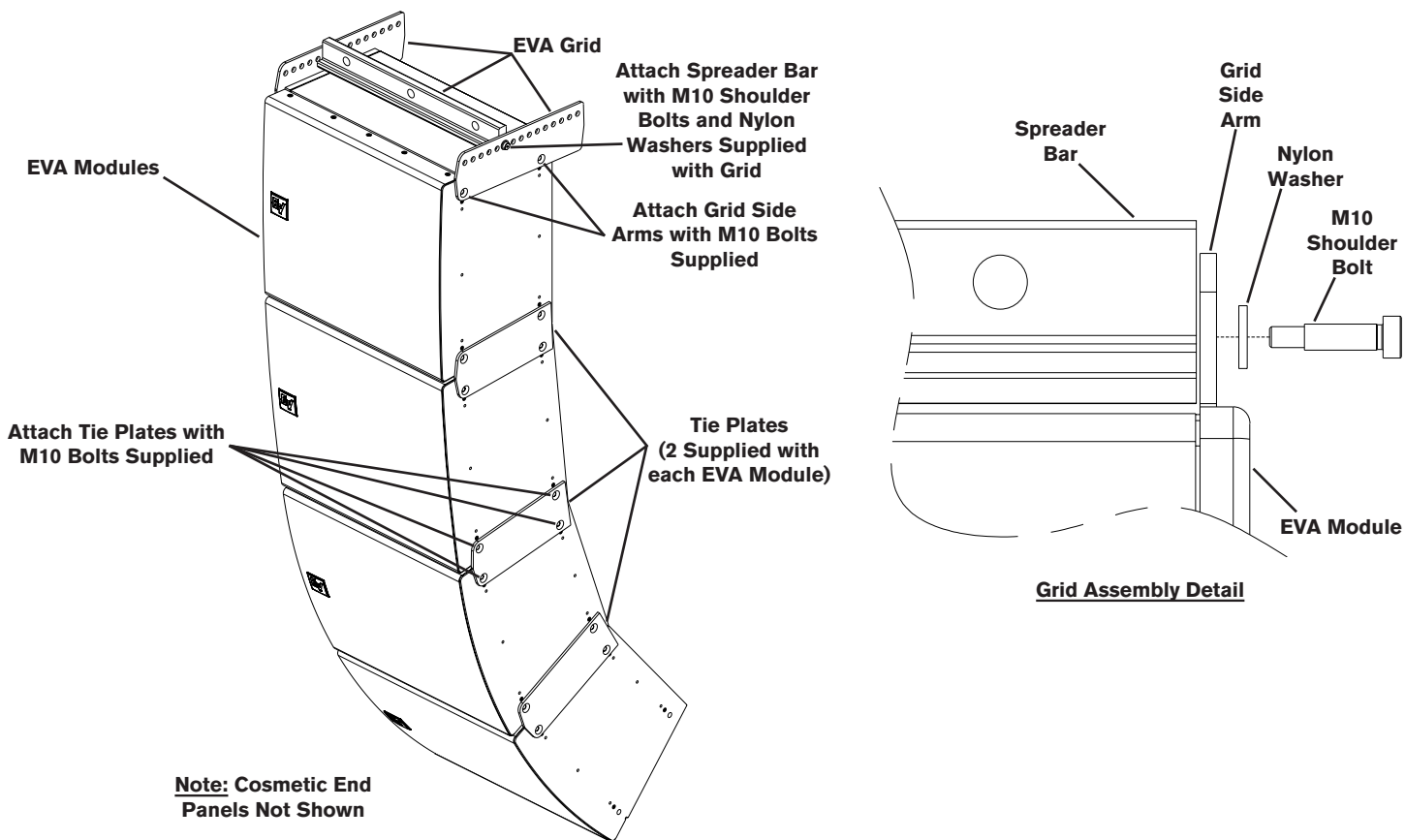

Figure 14:
Typical EVA flying system

5.0 EVA Rigging System (cont')

While 80-90% of EVA applications will be accommodated with arrays of three or four modules. Up to eight EVA modules may be suspended together up to a combined maximum loudspeaker column weight of 720 lbs.

5.2 Deciding Which Grid Configuration to Use with an EVA Array

5.2.1 Standard Grid with or without Second Spreader Bar

The EVA-SG standard grid is shown in Figure 15. This grid is appropriate for those 80-to-90% of applications covered by a three- to four-module array. It comes with one spreader bar and two side arms, plus the two shoulder bolts and nylon washers required to assemble the three parts into a grid. The spreader bar has three 0.813-inch (20.6 mm) holes through it, one near each end and one in the center, to which the chain hoist(s) or other device(s) used to lift the array into position can be attached. Using the two end points provides horizontal stability for the array. Using the center point will probably require a tie-off to stabilize the horizontal position of the array.

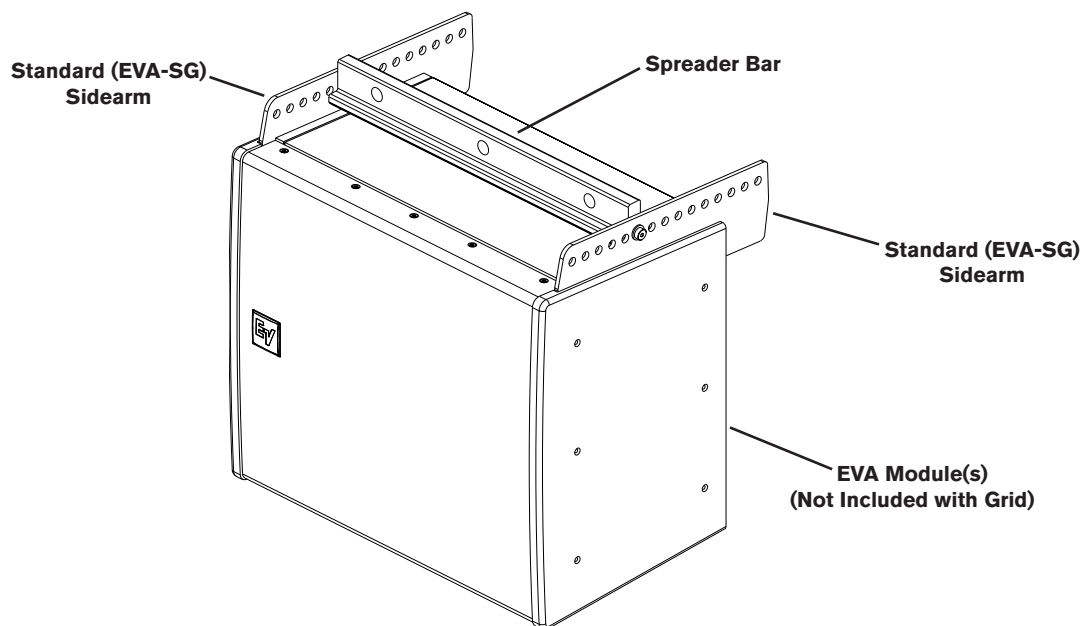

Figure 15:
EVA-SG grid (down angle of the array is determined by the front-to-back position of the spreader bar)

When the standard grid with its single spreader bar is used, the down angle of the array is determined by the front-to-back attachment position of the spreader bar. This information is provided by Electro-Voice's EVA Design Assistant (EVADA™), a function of the array makeup and desired vertical aiming. See section 3.0 Designing an EVA Array, above.

For arrays (1) larger than four EVA modules or (2) three- to-four-box arrays with extreme down angles, the extended grid is usually required. See section 5.2.2 Extended Grid with or without Second Spreader Bar, below.

5.0 EVA Rigging System (cont')

A second spreader bar, EVA-GXB, is available. The second spreader bar is used when two front-to-back pickup points are desired/required. Figure 16 shows an EVA-SG grid with a second spreader bar. When two spreader bars are used, one is attached to the extreme front hole positions in the side arms and the other is attached to the extreme rear position. This gives the most control over the vertical aiming of the array. Note that the need to maintain sufficient load on the front spreader bar to maintain rigging tension will diminish the amount of down angle available with a standard grid. For this reason the EVA-EG extended grid is probably a better choice when using front-to-back pickup points.

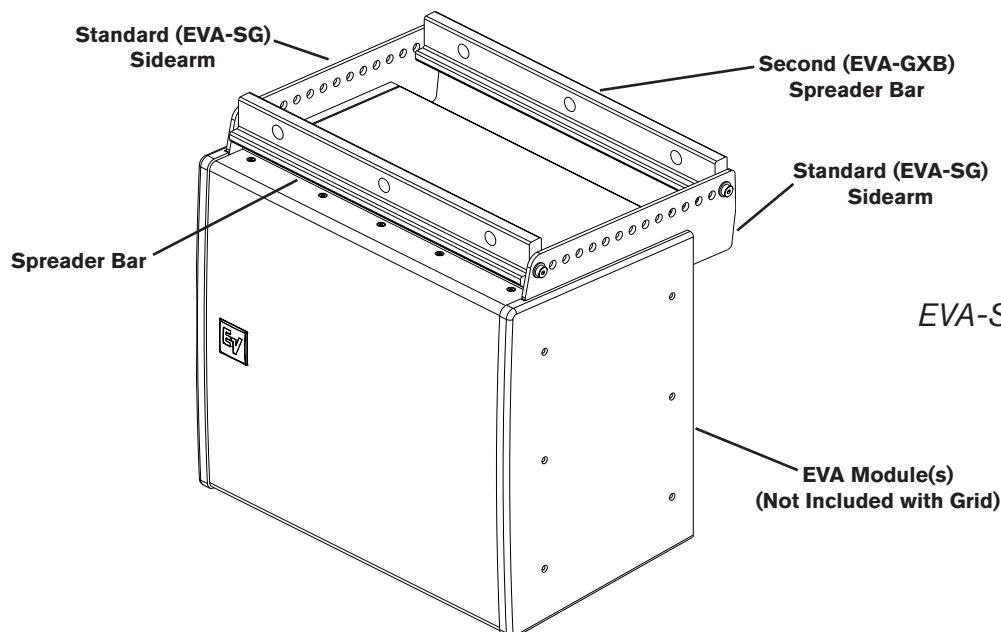

Figure 16:
*EVA-SG standard grid with optional
EVA-GXB spreader bar*

5.2.2 Extended Grid with or without Second Spreader Bar

The EVA-EG extended grid is also available. Arrays taller than four modules will probably require the extended grid, whose side arms are 12 inches longer to the rear. Three- to four-module arrays that have extreme down angles will also require the extended grid. Figure 17 shows the extended grid.

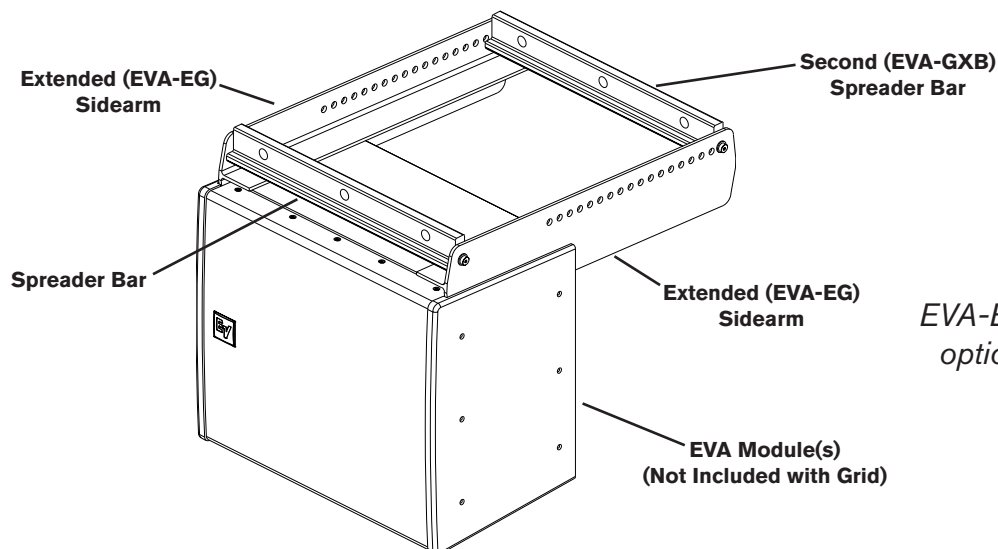

Figure 17:
*EVA-EG extended grid (shown with
optional EVA-GXB spreader bar)*

5.0 EVA Rigging System (cont')

5.23 Use of Two Standard Grids

Two EVA-SG standard grids may also be used with an EVA array, one attached to the upper module and the other attached to the lower module, acting as a pull-up grid. This is a way to achieve extreme down angles, such as might be encountered in a distributed arena system. Figure 18 shows this configuration. When using two grids in this fashion, the angle between the suspension lines must never be allowed to exceed 60°. **Do not use EVA-EG extended grids in this application.** For overall down angles of approx. 45° or greater, use the second-to-last hole of each grid. For overall down angles of less than approx. 45°, use the second-to-last hole on the bottom grid and any hole forward of second-to-last on the top grid.

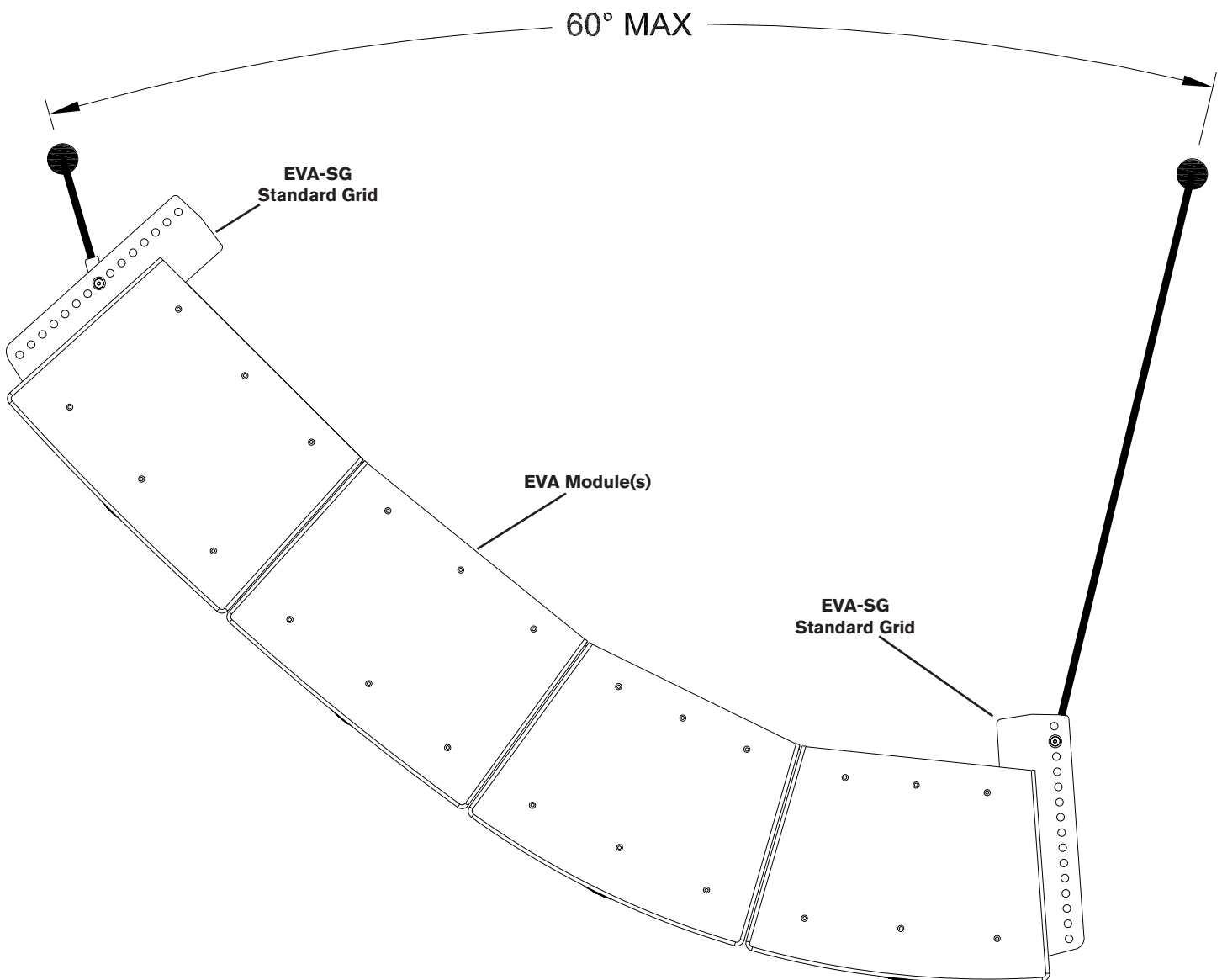

Figure 18:

The use of two EVA-SG standard grids to achieve extreme down angles

5.0 EVA Rigging System (cont')

5.3 Assembling and Flying an EVA Array

On each end of an EVA module are a pair of upper and lower connection points that accept the supplied M10 flathead bolts to either (1) attach the side arms of an EVA-SG standard grid or an EVA-EG extended grid to the top of the upper array module (or bottom of the lower array module as well) or (2) attach the tie plates supplied with each module so that the modules can be attached to each other. Figure 14 identifies these parts.

The first step in assembling an array is to attach the two side arms of the grid to the upper array module. Attach the side arms with the M10 bolts supplied and tighten securely. A single spreader bar is then attached to the side-arm holes shown in EVADA that provide the desired array aiming angle. See section 3.0 Designing an EVA Array, above. When two spreader bars are used they should be attached to the extreme front and back positions on the side arms, for maximum control over the array's vertical aiming angle.

Attach a chain hoist(s) or other lifting device(s) to the assembled grid and the upper EVA module. Then take the following steps:

1. Lift the assembly to the point where the second EVA module can just be slipped under the suspended partial array.
2. Using four M10 flathead screws (provided) attach a tie plate (flat end to the rear) to each end of the suspended module but do not fully tighten screws.
3. Move the second module into place under the suspended module between the tie plates.
4. Align the holes in the tie plates with the corresponding holes in the lower module and assemble to the one above with four M10 flathead screws (provided).
5. Fully tighten all eight M10 screws.
6. Connect the input terminals of the lowest module in parallel with the EVA modules above it.

Repeat the five steps above for attachment of additional EVA modules.

After the last module is attached, even though a tie plate will not be attached to its bottom end panels, install a pair of M10 screws per end panel where the tie plate would have attached in order to prevent audible air leaks.

Complete the array by attaching the cosmetic end panels, using the six M5 screws supplied for each panel. Tighten the screws by hand or use a power drill with a moderate torque setting. Over tightening will drive the screws through the wood of the end panels!

An array will typically be fed from the top down and it is recommended that as each module is added to the array it should be wired to the one above and the shading selector position set and verified per EVADA. Attenuation modules (if needed) may also be installed at this time. Note that shading and/or attenuation in the wrong place will seriously detract from the performance of the completed array!

The completed array may now be hoisted into position and secured in the final way intended.

6.0 Rigging-Strength Ratings and Safety Factors

6.1 Working-Load Limit and Safety Factor Definitions

The structural ratings for all of the EVA rigging components and complete loudspeaker systems are based on test results in which parts were stressed to failure. Manufacturers typically present the structural-strength ratings of mechanical components or systems as either the working-load limit (WLL) or the ultimate-break strength. Electro-Voice chooses to present the structural-load ratings of the EVA loudspeaker systems as the working-load limit. The working-load-limit rating represents the maximum load that should ever be applied to a mechanical component or system.



THE USER SHOULD NEVER APPLY A LOAD THAT EXCEEDS THE WORKING-LOAD LIMITS OF ANY OF THE RIGGING COMPONENTS OR COMPLETE LOUDSPEAKER SYSTEMS DESCRIBED IN THIS MANUAL.

The working-load limits for the EVA rigging components and complete loudspeaker systems described in this manual are based on a minimum 8:1 safety factor. The safety factor is defined as the ratio of the ultimate-break strength divided by the working-load limit, where the ultimate-break strength represents the force at which a part will structurally fail. For example, if a part has a working-load limit of 1,000 lb (454 kg), it would not structurally fail until a force of at least 8,000 lb (3,629 kg) was applied, based on an 8:1 safety factor. However, the user should never apply a load to that part that exceeds 1,000 lb (454 kg). The safety factor provides a margin of safety above the working-load limit to accommodate normal dynamic loading and normal wear.

CAUTIONS for Working-Load Limits and Safety Factors

The working-load limits defined by the manufacturer of any rigging component should never be exceeded. Electro-Voice bases the working-load limits of its EVA products on a minimum of an 8:1 safety factor. Other manufacturers of rigging components may base their working-load limits on safety factors other than 8:1. For example, 5:1 safety factors are fairly common amongst rigging manufacturers because many regulatory agencies call for a minimum safety factor of 5:1.

When an EVA loudspeaker system is installed where local regulations only require a safety factor of 5:1, Electro-Voice insists that the working-load limits of the EVA rigging never be exceeded and that an 8:1 safety factor be maintained for the EVA loudspeakers.

The user is cautioned that some local regulations may require safety factors higher than 8:1. In that circumstance, Electro-Voice insists that the user maintain the higher safety factor as required by the local regulations throughout the entire EVA installation. It is the responsibility of the user to make sure that any EVA installation meets all applicable local, state or federal safety regulations.

6.0 Rigging-Strength Ratings and Safety Factors (cont')

6.2 Structural Rating Overview

Designing a safe structural array is ordinarily a very complex process best left to experienced professionals. To make EVA systems both safe and easy to use, Electro-Voice engineers have chosen to treat EVA arrays as a single unified structure rather than individual components. All the complex factors listed below have been taken into account to design a rigging system strong enough to maintain a minimum 8:1 safety factor up to a maximum suspended column weight of **720 lb (327 kg)** at any elevation (tilt) angle available on either of the two EVA grids. The following is a short synopsis of the considerations involved:

There are two independent strength ratings that, together, give a complete description of the overall structural capabilities of any loudspeaker system; which are:

1. The strength of each individual enclosure rigging point; which is the combined strength of the internal rigging straps, external tie plates, bolts and enclosure.
2. The total strength of the overall array; which is a function of the combined forces from all of the rigging points acting on the rigging components and the array as a whole.

For grids, there are also two independent strength ratings that, together, give a complete description of the overall structural capabilities of the grid; which are:

1. The strength of each individual grid rigging point; which is the combined strength of the bolts, grid side arms and spreader bars.
2. The total strength of the overall grid; which is a function of the combined forces from all of the rigging points acting on the rigging components and the grid as a whole.

In any system, the forces acting on each loudspeaker (on each individual rigging point and on the overall enclosure) and the forces acting on each rigging accessory (grids and spreader bars) will vary with each array configuration. Determining those forces throughout an array requires complex mathematical calculations. Electro-Voice engineers have therefore defined a set of simplified structural-rating guidelines for EVA systems that eliminate the need for complex calculations. The interaction of the complex forces throughout EVA arrays was analyzed using a combination of destructive testing and computer modeling to develop this set of conservative guidelines, presented below, to enable a rigger to immediately determine on site whether or not an array is safe without having to make weight-distribution calculations.

6.0 Rigging-Strength Ratings and Safety Factors (cont')

6.3 Simplified Structural-Rating Guidelines

The simplified structural-rating guidelines for EVA loudspeakers are shown in Figure 19. These guidelines were determined based on the:

1. Vertical elevation possible with EVA-SG and EVA-EG grids.
2. Total weight of all enclosures in the array plus accessories, cabling and rigging.
3. Angled forces acting on rigging components and enclosures.

The resulting analysis has shown that any combination of EVA 6° vertical modules (EVA-2082S/906 and EVA-2082S/126) and EVA 20° vertical modules (EVA-2082S/920 and EVA-2082S/1220) may be rigged together at any vertical angle available from either a single EVA-SG or EVA-EG grid at the top of the array using one or two spreader bars or an EVA-SG grid and spreader bar at both the top and bottom of the array as long as the total column weight of suspended loudspeakers, accessories and cabling does not exceed **720 lb (327 kg)** and the angles of the suspension components are within the limits defined in Figures 20 through 22.

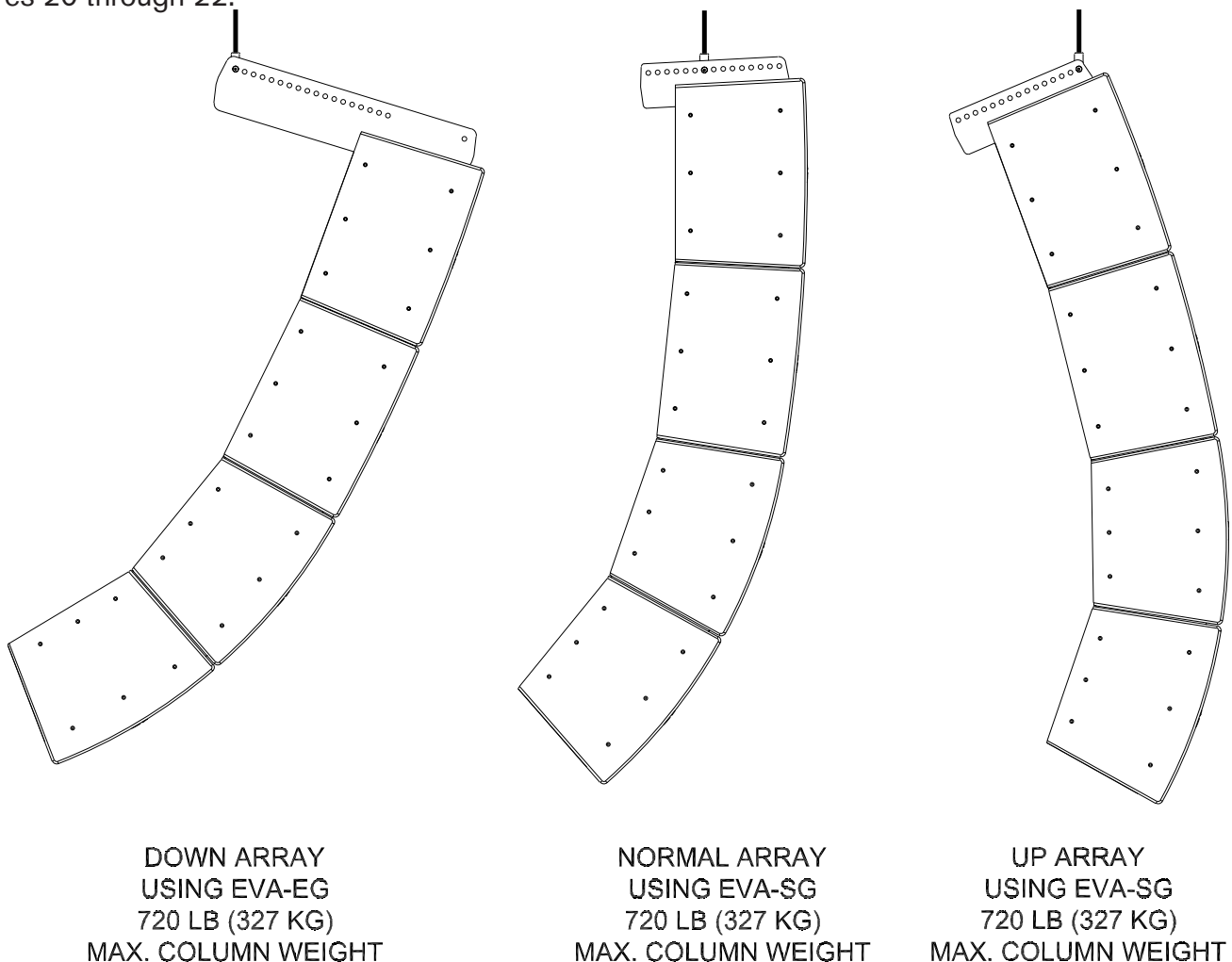

Figure 19:

Simplified structural-rating guidelines for EVA arrays

6.0 Rigging-Strength Ratings and Safety Factors (cont')



WHEN APPLYING THE STRUCTURAL RATING GUIDELINES TO ANY EVA LOUDSPEAKER SYSTEM SUSPENDED OVERHEAD, THE USER MUST OBEY THE FOLLOWING RULES:

1. Never exceed **720 lb (327 kg)** total column weight of suspended loudspeakers, accessories and cabling. (Typically 8 EVA 2082S modules)
2. If a second grid is used at the bottom of the array, the angle between the suspension lines must never be allowed to exceed 60° as shown in Figure 18. **Do not use EVA-EG grids in this application!**
3. The suspended column must be perpendicular (plumb) to within +/- 5 degrees as shown in Figure 20.
4. If a spreader bar is suspended from two points, the angle between those two suspension lines must not exceed 60 degrees (Maximum 30 degrees from plumb each) as shown in Figures 21 and 22.
5. **Never attempt to suspend EVA systems overhead by any other method than the use of EVA-SG or EVA-EG grids and spreader bars as outlined in this manual.**

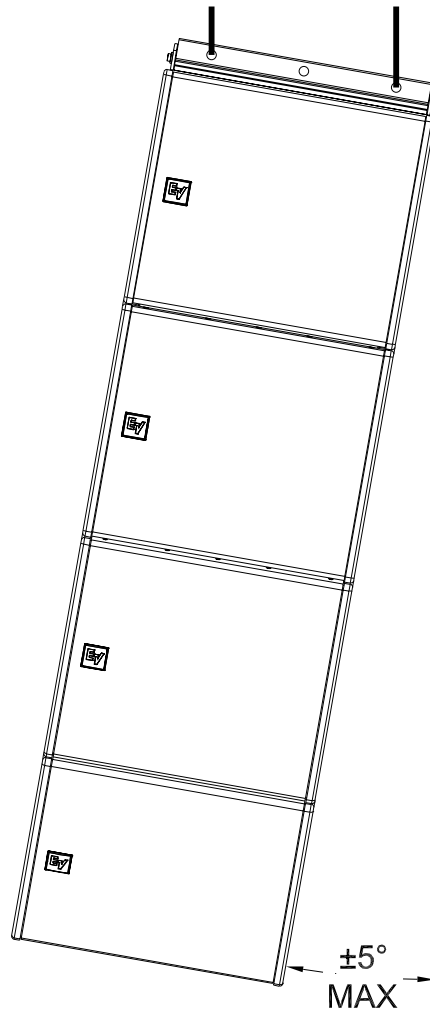

Figure 20:

Side-to-side simplified structural-rating guidelines for EVA arrays (angle shown exaggerated for illustration purposes)

6.0 Rigging-Strength Ratings and Safety Factors (cont')

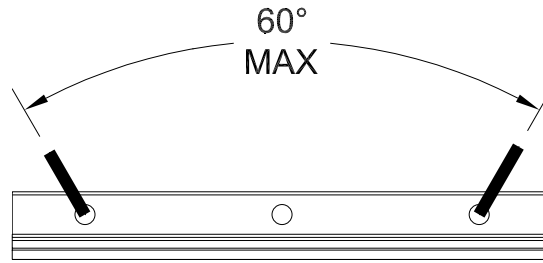

Figure 21:
Side-to-side angular pull structural-rating guidelines for EVA spreader bars

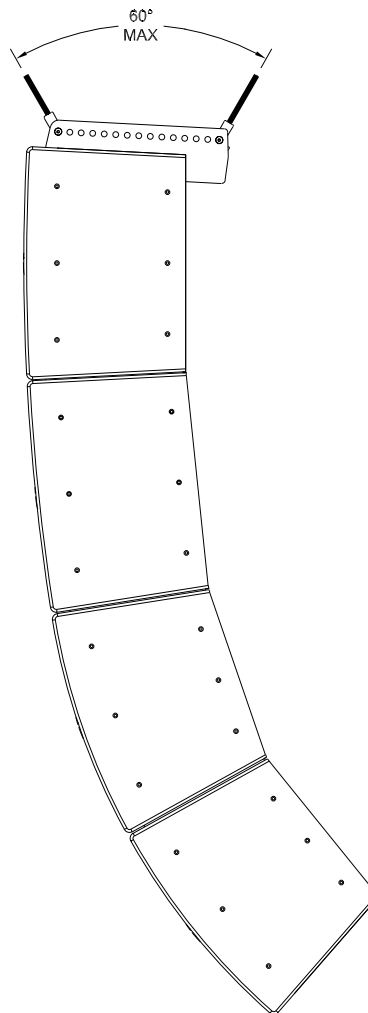

Figure 22:
Front-to-back angular pull structural-rating guidelines for EVA spreader bars

6.0 Rigging-Strength Ratings and Safety Factors (cont')

6.4 Electro-Voice Structural-Analysis Procedures

Electro-Voice maintains a structural pull-test facility in Burnsville, Minnesota USA which includes load cells with digital-electronic display and recording. The load cells are calibrated annually by an independent laboratory to a standard traceable to the United States National Bureau of Standards. This pull-test facility is capable of pulling to destruction both individual rigging components and complete loudspeaker systems.

Electro-Voice utilizes state-of-the-art computer-modeling programs for structural analysis throughout the development of loudspeaker systems. The computer modeling enables the complex forces in the rigging components and enclosures to be analyzed for loudspeakers assembled into arrays in both static and dynamic conditions.

Structural testing and computer modeling were used throughout the engineering development of all EVA individual rigging components and complete loudspeaker systems described in this manual. Testing and modeling involving both anticipated use and anticipated misuse were performed as part of the analysis. Engineering prototypes were stressed to failure and designs were revised based on those test results. Production systems and components were stressed to failure for verification of the final designs.



7.0 Rigging Inspections and Precautions

Electro-Voice EVA Loudspeaker Systems: Prior to each use, inspect the enclosures for any cracks, deformations or missing or damaged components that could reduce enclosure strength. Inspect the tie plates between enclosures for cracks, corrosion or other deformations that could reduce their strength and integrity. Check to be sure there are no missing screws and that all M10 rigging bolts are securely tightened. Hardware that is bent or showing signs of more than cosmetic surface corrosion should be replaced immediately.

Electro-Voice EVA Grids: Prior to each use, inspect the grid side bars and spreader bars for any cracks, corrosion, missing or damaged parts or any other deformation that could reduce their strength and integrity. Make sure there are no missing bolts and be sure all M10 rigging bolts are tightened securely. Hardware that is bent or showing signs of more than cosmetic surface corrosion should be replaced immediately.

Lifting Hoists: Prior to each use, inspect the lifting hoist(s) and associated hardware (including motor(s), if applicable) for any cracks, deformation, broken welds, corrosion, missing or damaged components that could reduce the hoist strength. Replace any damaged hoists. Never exceed the limitations or maximum recommended load specified by the hoist manufacturer. Always follow manufacturers' recommendations for operation, inspection, and certification. Always raise and lower the load slowly and evenly, avoiding any rapid changes in speed or shifting loads that could result in a sudden jolt to the suspended system or the structure from which it is suspended.

Building, Tower or Scaffold Supports: Prior to each use, the strength and load-bearing capabilities of the building, tower or scaffold structural supports should be evaluated and certified by a professional engineer as being adequate for supporting the intended rigging system (including the loudspeakers, grids, chain hoists and all associated hardware). Prior to each use, inspect the building, tower or scaffold structural supports for any cracks, deformation, broken welds, corrosion, missing or damaged components that could reduce the structural strength. Damaged structural supports should be replaced or repaired and recertified by a professional engineer. Never exceed the limitations or maximum recommended load for the supports.

Miscellaneous Mechanical Components: Prior to each use, inspect all mechanical components (chain, wire ropes, slings, shackles, hooks, fittings, ratchet straps, etc.) for any cracks, deformation, broken welds, slipping crimps, fraying, abrasion, knots, corrosion, chemical damage, loose screws, missing or damaged components that could reduce the maximum strength specified by the component manufacturer. Replace any damaged mechanical components immediately. Never exceed the limitations or maximum recommended load for the mechanical components.

8.1 Rigging (printed)

- [1] W.E. Rossnagel, L.R. Higgins & J.A. MacDonald, Handbook of Rigging for Construction and Industrial Operations, McGraw-Hill Book Company, New York, NY, USA (1988).
- [2] H. Donovan, Entertainment Rigging, <http://www.riggingbooksandprograms.com>, Rigging Seminars, Seattle, WA, USA (2002)
- [3] J.O. Glerum, Stage Rigging Handbook, Southern Illinois University Press, Carbondale, IL, USA (1987).
- [4] P. Carter, Backstage Handbook, Broadway Press, New York, NY, USA (1988).
- [5] ATM Fly-Ware™, Riggermeister Production Rigging Guide, ATM Fly-Ware™, Carson, CA, USA (1995).
- [6] Wire Rope Technical Board, Wire Rope Users Manual, American Iron and Steel Institute, Stevensville, MD, USA (1985).
- [7] Broderick & Bascom Rope Company, Rigger's Handbook, Sedalia, MO, USA (1993).
- [8] MacWhite Wire Rope Company, Catalog of Tables, Data and Helpful Information, Kenosha, WI, USA (1991).
- [9] Acco Chain & Lifting Division, Chain Sling User's Manual, Acco Corporation, York, PA, USA (1992).
- [10] Newberry, W.G., Handbook for Riggers, Newberry Investments Company, Calgary, Alberta, Canada (1989).

8.2 Mechanical Engineering (printed)

- [1] R.C. Hibbeler, Engineering Mechanics Statics & Dynamics, Pearson Prentice Hall, Upper Saddle River, NJ, USA (2005)
- [2] R.C. Hibbeler, Mechanics of Materials, Pearson Prentice Hall, Upper Saddle River, NJ, USA (2005)
- [3] J.L. Meriam & L.G. Kraige, Engineering Mechanics, Volume One - Statics, John Wiley & Sons, Inc., New York, NY, USA (1992).
- [4] J.L. Meriam & L.G. Kraige, Engineering Mechanics, Volume Two - Dynamics, John Wiley & Sons, Inc., New York, NY, USA (1992).
- [5] J.E. Shigley & C.R. Mischke, Mechanical Engineering Design, McGraw-Hill Book Company, New York, NY, USA (1989).

8.0 References (cont')

8.3 Rigging (Web sites)

[1] <http://www.rigging.net>

[2] <http://www.cmworks.com/>

[3] <http://catalog.thecrosbygroup.com/maininterface.htm>



Notes

Electro-Voice®

12000 Portland Avenue South, Burnsville, MN 55337
Phone: 952/884-4051, Fax: 952/884-0043

www.electrovoice.com

© Bosch Communications Systems

12/2008

Part Number LIT000350 Rev 1

U.S.A. and Canada only. For customer orders, contact Customer Service at:
800/392-3497 Fax: 800/955-6831

Europe, Africa, and Middle East only. For customer orders, contact Customer Service at:
+ 49 9421-706 0 Fax: + 49 9421-706 265

Other International locations. For customer orders, Contact Customer Service at:
+ 1 952 884-4051 Fax: + 1 952 887-9212

For warranty repair or service information, contact the Service Repair department at:
800/685-2606

For technical assistance, contact Technical Support at: **866/78AUDIO**

Specifications subject to change without notice.

Free Manuals Download Website

<http://myh66.com>

<http://usermanuals.us>

<http://www.somanuals.com>

<http://www.4manuals.cc>

<http://www.manual-lib.com>

<http://www.404manual.com>

<http://www.luxmanual.com>

<http://aubethermostatmanual.com>

Golf course search by state

<http://golfingnear.com>

Email search by domain

<http://emailbydomain.com>

Auto manuals search

<http://auto.somanuals.com>

TV manuals search

<http://tv.somanuals.com>