

# GMA 240

# Installation Manual



---

© Copyright 2008  
Garmin Ltd. or its subsidiaries  
All Rights Reserved

Except as expressly provided herein, no part of this manual may be reproduced, copied, transmitted, disseminated, downloaded or stored in any storage medium, for any purpose without the express prior written consent of Garmin. Garmin hereby grants permission to download a single copy of this manual and of any revision to this manual onto a hard drive or other electronic storage medium to be viewed and to print one copy of this manual or of any revision hereto, provided that such electronic or printed copy of this manual or revision must contain the complete text of this copyright notice and provided further that any unauthorized commercial distribution of this manual or any revision hereto is strictly prohibited.

Garmin International, Inc.  
1200 E. 151st Street  
Olathe, KS 66062 USA  
Telephone: 913.397.8200  
Aviation Panel-Mount Technical Support Line (Toll Free) 1.888.606.5482  
[www.garmin.com](http://www.garmin.com)

Garmin (Europe) Ltd.  
Liberty House, Bulls Copse Road  
Hounslow Business Park  
Southampton, SO40 9RB U.K.  
+44/ (0) 870.8501241

Garmin AT, Inc.  
2345 Turner Rd., SE  
Salem, OR 97302 USA  
Telephone: 503.581.8101

### **RECORD OF REVISIONS**

<b>Revision</b>	<b>Revision Date</b>	<b>Description</b>
A	06/09/08	Initial Release

---

## **INFORMATION SUBJECT TO EXPORT CONTROL LAWS**

This document may contain information which is subject to the Export Administration Regulations ("EAR") issued by the United States Department of Commerce (15 CFR, Chapter VII, Subchapter C) and which may not be exported, released, or disclosed to foreign nationals inside or outside of the United States without first obtaining an export license. The preceding statement is required to be included on any and all reproductions in whole or in part of this manual.

<b>WARNING</b>
----------------

This product, its packaging, and its components contain chemicals known to the State of California to cause cancer, birth defects, or reproductive harm. This Notice is being provided in accordance with California's Proposition 65. If you have any questions or would like additional information, please refer to our web site at [www.garmin.com/prop65](http://www.garmin.com/prop65).

### **DOCUMENT PAGINATION**

<b>Section</b>	<b>Page Range</b>
Table of Contents	i – vi
Section 1	1-1 – 1-6
Section 2	2-1 – 2-6
Section 3	3-1 – 3-4
Section 4	4-1 – 4-8
Appendix A	A-1 – A-6
Appendix B	B-1 – B-8
Appendix C	C-1 – C-2

---

This page intentionally left blank

---

## TABLE OF CONTENTS

PARAGRAPH	PAGE
1 GENERAL DESCRIPTION .....	1-1
1.1 Introduction.....	1-1
1.2 Equipment Description .....	1-1
1.3 Technical Specifications .....	1-2
1.4 Reference Documents .....	1-4
1.5 Limited Warranty.....	1-5
2 INSTALLATION OVERVIEW .....	2-1
2.1 Introduction.....	2-1
2.2 Installation Materials .....	2-1
2.3 GMA 240 Wiring, Configuration, and Adjustment Options .....	2-1
2.4 Noise .....	2-5
2.5 GMA 240 Mounting .....	2-6
3 INSTALLATION PROCEDURE.....	3-1
3.1 Unpacking Unit.....	3-1
3.2 Electrical Connections .....	3-1
3.3 Audio Shield Termination .....	3-2
3.4 GMA 240 Installation .....	3-2
3.5 Post Installation Checkout .....	3-3
3.6 Configuration Adjustments.....	3-4
3.7 Continued Airworthiness .....	3-4
4 SYSTEM INTERCONNECTS.....	4-1
4.1 Connector Description .....	4-1
4.2 Pin List.....	4-1
4.3 Aircraft Power and Lighting .....	4-4
4.4 Configuration Pins .....	4-5
4.5 Audio Inputs/Outputs and Mic Keys .....	4-6

---

PARAGRAPH	PAGE
APPENDIX A OUTLINE AND INSTALLATION DRAWINGS.....	A-1
APPENDIX B INTERCONNECT DRAWINGS .....	B-1
APPENDIX C CONFIGURATION JUMPER DRAWINGS.....	C-1

---

## LIST OF ILLUSTRATIONS

FIGURE	PAGE
1-1 GMA 240 Unit View .....	1-1
2-1 GMA 240 Unit Rack (115-00262-00) .....	2-4
3-1 Audio Shield Termination .....	3-2
3-2 Access Hole Location (Top View) .....	3-5
4-1 Backshell Rear Connector Plate.....	4-1
4-2 Rear Connectors J2401 & J2402, Viewed from Back of Unit.....	4-1
A-1 GMA 240 Outline Drawing .....	A-1
A-2 GMA 240 Connector/Rack Assembly Drawing .....	A-3
A-3 GMA 240 Recommended Panel Cutout Dimensions .....	A-5
B-1 GMA 240 Interconnect Drawing (page 1 of 3).....	B-1
B-1 GMA 240 Interconnect Drawing (page 2 of 3).....	B-3
B-1 GMA 240 Interconnect Drawing (page 3 of 3).....	B-5
B-2 GMA 240, J2401 & J2402 Connector Layout Drawing.....	B-7
C-1 GMA 240 Internal Configuration Jumper Layout Drawing .....	C-1

## LIST OF TABLES

TABLE	PAGE
3-1 Recommended Crimp Tools .....	3-1
4-1 J2401 Pin Assignments .....	4-2
4-2 J2402 Pin Assignments .....	4-3

---

### **GMA 240 HARDWARE MOD LEVEL HISTORY**

The following table identifies hardware modification (Mod) Levels for the GMA 240 Audio Panel. Mod Levels are listed with the associated service bulletin number, service bulletin date, and the purpose of the modification. The table is current at the time of publication of this manual (see date on front cover) and is subject to change without notice. Authorized Garmin Sales and Service Centers are encouraged to access the most up-to-date bulletin and advisory information on the Garmin Dealer Resource web site at [www.garmin.com](http://www.garmin.com) using their Garmin-provided user name and password.

<b>MOD LEVEL</b>	<b>SERVICE BULLETIN NUMBER</b>	<b>SERVICE BULLETIN DATE</b>	<b>PURPOSE OF MODIFICATION</b>



# 1 GENERAL DESCRIPTION

## 1.1 Introduction

This manual provides the installation instructions for the Garmin GMA 240 Audio Panel. Reference to GMA 240 throughout this manual refers to all versions of the unit. Information pertaining to the maintenance of the unit can be found in the GMA 240 Maintenance Manual, P/N 190-00917-02. Information pertaining to the operation of the unit can be found in the GMA 240 Pilot's Guide, P/N 190-00917-00.

## 1.2 Equipment Description

The Garmin GMA 240 Audio Panel is not a TSO-certified product and has received no FAA approval or endorsement.

The GMA 240 meets the needs of aircraft owners and operators who require reliability and versatility in the essential audio switching function. LED-illuminated push-button simplicity and intuitive panel layout allow audio selection of both NAV and COM audio. Large, single-button activation of the COM microphone and audio for two COM transceivers simplifies cockpit workload. Photocell dimming circuitry automatically adjusts the brightness of the annunciators to a level appropriate for ambient cockpit light. A fail-safe circuit connects the pilot's headset and microphone directly to COM1 and a fail-safe warning audio input in the event that power is interrupted or the unit is turned off.

Additionally, the GMA 240 includes a four-position intercom (ICS) with electronic cabin noise de-emphasis, two stereo music inputs, and independent pilot and copilot/passenger volume controls. To further simplify the cockpit workload, the intercom provides for pilot isolation. One hundred percent solid state circuitry and extensive use of surface mount technology are employed.



Figure 1-1. GMA 240 Unit View

---

## 1.2.1 Features Summary

- User-friendly, intuitive front panel layout
- LEDs indicate selected function
- Four position intercom: pilot, copilot, two passengers
- Two stereo headset amplifiers: one for pilot, one for copilot/passengers
- Two differential stereo music source inputs
- Front panel music volume control, source selection, and master music on/off switch
- Front panel controls for music muting by intercom and selected radios
- Two selectable intercom operational modes
- Selectable aural pushbutton annunciation (beep)
- Independent pilot, copilot/passenger intercom volume and squelch controls
- Individual VOX circuits for each of four (4) mic inputs
- Automatic selection of COM audio source when corresponding mic is selected
- Memory of explicitly selected COM audio source(s) when changing COM mic selection
- MASQ™ Processing with configurable mute threshold
- COM swap function
- PTT indication
- Power-off fail-safe to connect Pilot PTT, mic, and Headset to COM 1 if unit is turned off
- Power-off fail-safe warning audio input
- Full duplex Telephone interface
- Front Panel Mini-Jack (MP3 player, cellular phone, etc.)

## 1.3 Technical Specifications

### 1.3.1 Physical Characteristics

Characteristic	Specification
Bezel Height	1.30 inches (33 mm)
Bezel Width	6.29 inches (159.77 mm)
Rack Height (Dimple to Dimple)	1.33 inches (34 mm)
Rack Width	6.30 inches (160.02 mm)
Depth Behind Panel with Connectors (measured from face of aircraft panel to rear of connector backshells)	7.12 inches (181 mm)
GMA 240 Weight (Unit Only)	15.5 oz (440 g)
GMA 240 Weight (Installed with rack and connectors)	24 oz (680 g)

### 1.3.2 Electrical Characteristics

Characteristic	Specification
Temperature Range	-20°C to +55°C (operation) -55°C to +85°C (storage)
Altitude	55,000 Feet
Audio Panel Functions	Dedicated Transceiver inputs: 3 (including TEL) Dedicated Receiver inputs: 4 (all independently selectable) Alert (unswitched) inputs: 3 (each with configurable volume) Input impedance: 500 Ω Input isolation: 60 dB minimum Alert/Receiver/Transceiver bandwidth: 100 Hz to 6.5 kHz Special functions: Fail-safe operation MASQ™ processing (Master Avionics Squelch) Configurable button push aural annunciation
Intercom Functions	Positions: 4 (pilot, copilot, 2 passengers) Volume controls: 3 (pilot, copilot/passengers, music) VOX level controls: 2 (pilot, copilot/passengers) VOX circuits: 4 (one per mic input) Microphone input impedance: 450 Ω (compatible with 150 to 600 Ω mics) Microphone bias voltage: about 10 Vdc delivered through 450 Ω Microphone response: 9-pole characteristic cabin noise de-emphasis Intercom isolation modes: 2 – all, pilot (or configure for all, crew) Telephone interfaces: 1 full-duplex (use LRU pins or front jack)
Headphone Outputs	Output amplifiers: 2 stereo (pilot, copilot/passengers) Fidelity:    Load            Power            Distortion (typ.) 150 Ω            50 mW            <0.03% THD+N 150 Ω            100 mW           <0.07% THD+N 50 Ω             150 mW           <0.07% THD+N 50 Ω             300 mW           <0.10% THD+N  Compatible with higher headphone impedances, those shown are for worst-case distortion and bandwidth

Characteristic	Specification
Music Functions	<p>Music inputs (stereo): 2</p> <p>Music input impedance: 600 <math>\Omega</math> (differential)</p> <p>Music gain: -20dB @ min volume, +26dB @ max. volume (typ.)</p> <p>Music input level: &lt;200 mVrms for full power* output @ max music volume knob position (typ.) 3.5 Vrms max music input level</p> <p>Music bandwidth: 20 Hz to 20 kHz @ full power output</p> <p>Music distortion: &lt;0.1% THD+N (typ.) @ full power, full bandwidth</p> <p>Special Functions: Front panel selection and volume control Front panel control for muting by radios and ICS Muting by alerts configurable</p> <p>*Full power output refers to 300 mW into 50 <math>\Omega</math> (three 150 <math>\Omega</math> headsets in parallel each driven to 100 mW)</p>
Front Panel Mini-Jack Functions	<p>Input Impedance: 5.1 k<math>\Omega</math></p> <p>Music Input: Auto detection of music source will use jack as Music 1</p> <p>Telephone Input: Auto detection of TEL source will use jack for TEL Telephone ring signal is heard without TEL selected</p>

### 1.3.3 Power Requirements

Characteristic	Specification
Input Voltage Range	11 to 33 Vdc
Power Input	4.3 W normal operation (310mA @ 13.8 V) 7.5 W max. operation (540 mA @ 13.8 V)

## 1.4 Reference Documents

The following publications are sources of additional information for installing the GMA 240. Before installing the unit, the technician should read all referenced materials along with this manual.

Part Number	Document
190-00917-00	GMA 240 Pilot's Guide
190-00917-02	GMA 240 Maintenance Manual

---

## 1.5 Limited Warranty

This Garmin product is warranted to be free from defects in materials or workmanship for one year from the date of purchase. Within this period, Garmin will at its sole option, repair or replace any components that fail in normal use. Such repairs or replacement will be made at no charge to the customer for parts or labor, provided that the customer shall be responsible for any transportation cost. This warranty does not cover failures due to abuse, misuse, accident or unauthorized alteration or repairs.

THE WARRANTIES AND REMEDIES CONTAINED HEREIN ARE EXCLUSIVE AND IN LIEU OF ALL OTHER WARRANTIES EXPRESS OR IMPLIED OR STATUTORY, INCLUDING ANY LIABILITY ARISING UNDER ANY WARRANTY OF MERCHANTABILITY OR FITNESS FOR A PARTICULAR PURPOSE, STATUTORY OR OTHERWISE. THIS WARRANTY GIVES YOU SPECIFIC LEGAL RIGHTS, WHICH MAY VARY FROM STATE TO STATE.

IN NO EVENT SHALL GARMIN BE LIABLE FOR ANY INCIDENTAL, SPECIAL, INDIRECT OR CONSEQUENTIAL DAMAGES, WHETHER RESULTING FROM THE USE, MISUSE, OR INABILITY TO USE THIS PRODUCT OR FROM DEFECTS IN THE PRODUCT. Some states do not allow the exclusion of incidental or consequential damages, so the above limitations may not apply to you.

Garmin retains the exclusive right to repair or replace the unit or software or offer a full refund of the purchase price at its sole discretion. SUCH REMEDY SHALL BE YOUR SOLE AND EXCLUSIVE REMEDY FOR ANY BREACH OF WARRANTY.

To obtain warranty service, contact your local Garmin Authorized Service Center. For assistance in locating a Service Center near you, call Garmin Customer Service at one of the numbers shown below.

Products sold through online auctions are not eligible for rebates or other special offers from Garmin. Online auction confirmations are not accepted for warranty verification. To obtain warranty service, an original or copy of the sales receipt from the original retailer is required. Garmin will not replace missing components from any package purchased through an online auction.

Garmin International, Inc.  
1200 East 151st Street  
Olathe, Kansas 66062, U.S.A.  
Phone: 913/397.8200  
FAX: 913/397.8282

Garmin (Europe) Ltd.  
Liberty House, Bulls Copse Road  
Hounslow Business Park  
Southampton, SO40 9RB, U.K.  
Phone: +44/0870.851241  
FAX: +44/0870.851251

---

Blank Page

---

## 2 INSTALLATION OVERVIEW

### 2.1 Introduction

This section provides the necessary information for the installation and checkout of the GMA 240 Audio Panel. Installation of the GMA 240 will differ according to equipment location and other factors. Cabling will be fabricated by the installing agency to fit these various requirements. The appendices contain interconnect wiring diagrams, mounting dimensions, and information pertaining to installation.

### 2.2 Installation Materials

#### 2.2.1 Equipment Available

GMA 240 Audio Panel, Ship Level Assembly, P/N 010-00735-() includes the following, depending on part number:

Item	Garmin P/N
Connector Kit, GMA 340	011-00652-00
Rack Backplate, GMA 340	011-00678-00
Unit Assembly, GMA 240	011-01988-00
Audio Cables, 2.5 mm RA Stereo Plug	011-02079-00
Install Rack, GMA 340	115-00262-00

#### 2.2.2 Additional Equipment Required

- Cables: The installer will fabricate and supply all system cables. Interconnect wiring diagrams are detailed in Appendix B.
- Hardware: #6-32 100° flat head screw (6 ea.) and #6-32 self-locking nut (6 ea.). Hardware required to mount the installation rack is not provided.
- Stereo headphone jacks (up to 4), microphone jacks (up to 4), 3.5mm stereo jacks (up to 2). Insulating type jacks or insulating washers should be used for all jacks to isolate them from aircraft chassis.

### 2.3 GMA 240 Wiring, Configuration, and Adjustment Options

The GMA 240 has several configuration/adjustment options, consideration of these options should be discussed with the end user(s) of the aircraft before wiring begins. These configuration/adjustments are described in the following sections:

- Wiring options – Sections 2.3.1 and 4.4.1
- Internal configuration jumpers - Section 2.3.1
- Volume/Mute adjustments - Section 2.3.2

### 2.3.1 Internal Configuration Jumpers

The following internal configuration adjustments may be made by removing or replacing jumpers on the PCB. The jumper positions are designed to accept a 0 Ω resistor of 0603 size. Refer to Appendix C for component location.

This service should only be performed by a qualified technician. Garmin is not responsible for damage caused during adjustment of these internal configuration jumper settings. Refer to the GMA 240 Maintenance Manual for disassembly/reassembly instructions.



The GMA 240 contains static sensitive components. Observe proper anti-static procedures when performing any solder procedures on the unit.

Component	Name	Default	Description
R0303	Alert Mutes Music	Populated	If this jumper is removed, music will not be interrupted by alert audio. Default operation is recommended.
R0304	COM1 Internal Sidetone	Empty	If a jumper is supplied in these positions, internal sidetone will be heard during PTT to simulate received sidetone from a radio that does not provide one during transmission. This should only be used if a radio does not perform this function already.
R0305	COM2 Internal Sidetone	Empty	
R0308	TEL Internal Sidetone	Populated	If this jumper is removed, intercom audio and intercom sidetone will not be heard when the TEL button is selected. Many phones supply sidetone when a call is in session. This causes a noticeable change in intercom sound quality but it is usually not disruptive. Default operation is recommended unless the effect of sidetone from the telephone is disruptive to intercom operation.
R0315	TEL jack detect bypass	Empty	If a jumper is supplied in this position, when TEL is selected the audio panel will assume a telephone is in use in the front jack regardless of phone detection. This should be used only if the audio panel is not capable of properly detecting the telephone that will be used in the installation.



Component	Name	Default	Description
R0314	Only Primary COM mutes MUSIC	Empty	If a jumper is supplied in this position, the RADIO button will mute music only when the Primary COM (the COM selected for transmission) is receiving audio. Default RADIO mutes music operation occurs when any selected COM / NAV / AUX radio is receiving audio.
R0313	Enable KEYED ICS	Empty	If a jumper is supplied in this position, the intercom system (ICS) will only allow intercom MIC audio to be heard when the corresponding ICS KEY for the MIC position is pressed. When this configuration is used, the VOX knobs should be set fully CCW (live MIC). See section 4.5.2 for information on wiring intercom keys.
R0312	Reserved	Empty	Reserved
R0309	Reserved	Empty	Reserved
R0302	Reserved	Empty	Reserved
R0301	Reserved	Empty	Reserved
R0300	Reserved	Empty	Reserved

### 2.3.2 VOLUME/MUTE Configuration Adjustments

The following adjustments can be made through access holes in the top cover of the GMA 240:

1. Alert 1 Volume
2. Alert 2 Volume
3. Alert 3 Volume
4. Rear connector TEL input volume
5. Front panel jack TEL input volume
6. MASQ (Master Avionics Squelch) mute level

Refer to Figure 2-1 for the location of the access holes.

**CAUTION**

Exercise care when inserting adjustment tools through the top cover. Damage to the unit may occur if an adjustment tool is accidentally forced against unintended components or circuit board paths. Use a 2 mm (max blade width) flat-blade non-conductive screw driver or adjustment tool.

CW adjustment increases the levels for volume inputs and for the mute threshold for radio inputs.

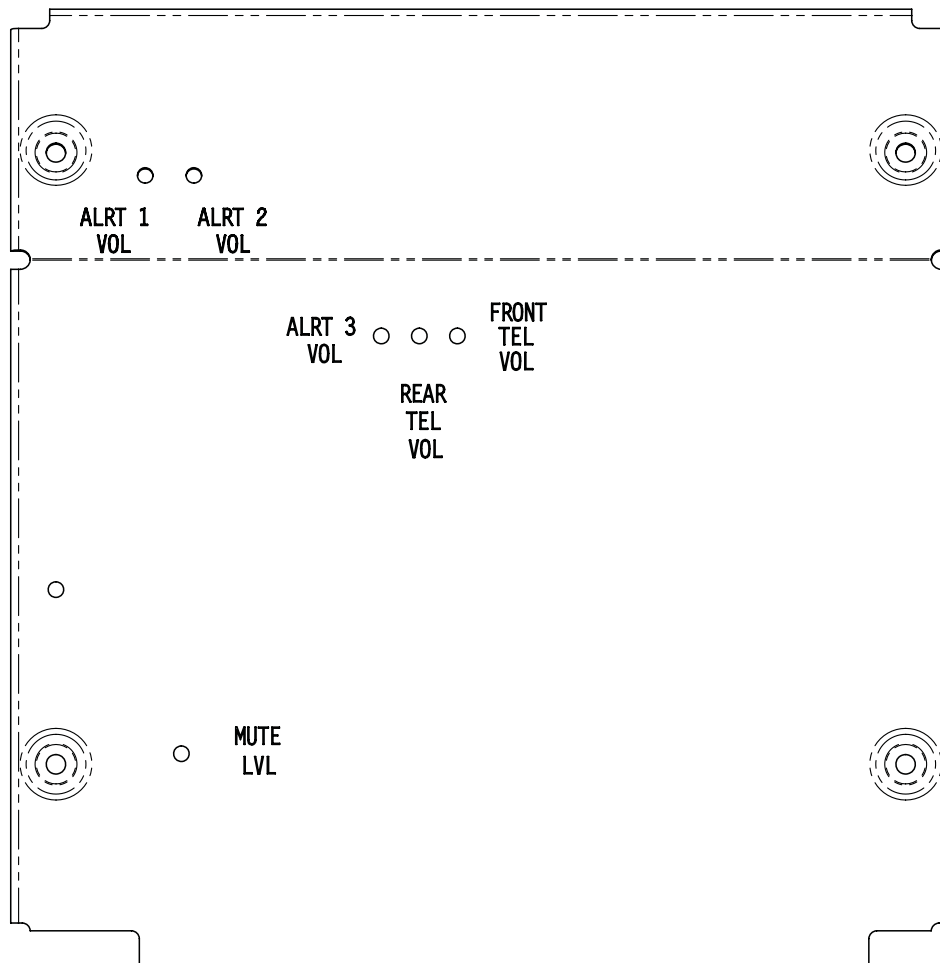

**Figure 2-1. Access Hole Location (Top View)**

### 2.3.3 Hardwire Configuration Option

The following configuration options are available by externally wiring pins to aircraft chassis. When change of operation is desired during flight, these can optionally be wired to chassis through a suitable switch mounted in reach of the operator. See Section 4.4.1 for connector and pin details for implementing these configuration options.

**MASQ™ INHIBIT:** The Master Avionics SQuelch inhibit configuration option allows selected avionics audio inputs (COM, NAV, AUX) and alerts to be heard even if they do not exceed the MASQ threshold. This increases background noise during otherwise quiet operation because noise from these inputs is not squelched. This option is most useful as a troubleshooting tool.

**CREW ISO:** This input configures the audio panel for crew intercom isolation in place of pilot isolation. When the PILOT ISO key is selected, the pilot and copilot will hear each other but will be isolated from the passengers. When the CREW ISO configuration is selected, the copilot's headphone jack must be wired in parallel with the pilot headset output. Microphones are wired as normal.

**PILOT ISO MUSIC:** This input configures music to be heard by the pilot during PILOT ISO mode (or by the pilot and copilot if crew isolate mode is configured). Normally, the isolated ICS positions do not hear music.

---

**BUTTON PRESS TONE ENABLE:** This input enables an audible tone to be heard when a button press is detected.

**MUTE ON COM TX:** This input configures the audio panel to mute all selected radios (COM, NAV, AUX) except the mic selected COM (COM selected for transmission) when a PTT key is activated for COM transmit.

## **2.4 Noise**

Because the audio panel is a point in the aircraft where signals from many pieces of equipment are brought together, care must be taken to minimize effects from coupled interference and ground loops.

Coupled interference can sneak into audio system interconnecting cables when they are routed near large AC electric fields, AC voltage sources, and pulse equipment (strokes, spark plugs, magnetos, EL displays, CRTs, etc). Interference can also couple into audio system interconnecting cables by magnetic induction when they are routed near large AC current-carrying conductors or switched DC equipment (heaters, solenoids, fans, autopilot servos, etc).

Ground loops are created when there is more than one path in which return currents can flow, or when signal returns share the same path as large currents from other equipment. These large currents create differences in ground potential between the various equipment operating in the aircraft. These differences in potential can produce an additive effect at an audio panel signal input.

The audio panel may “see” the desired input signal plus an unwanted component injected by ground differentials, a common cause of alternator-related noise. This is the main reason why all audio jacks should be isolated from ground. Terminating audio shields just at one end eliminates another potential ground loop injection point.

Single-point grounding cannot be overstressed for the various avionics producing and processing audio signals. Single-point, in this context, means that the various pieces of equipment share a single common ground connection back to the airframe. Good aircraft electrical/charging system ground bonding is also important.

The wiring diagrams and accompanying notes in this manual should be followed closely to minimize noise effects.

---

## 2.5 GMA 240 Mounting

The GMA 240 mounting surface must be capable of providing structural support and electrical bond to the aircraft to minimize radiated EMI and provide protection from High-Intensity Radiation Fields (HIRF).

The GMA 240 is mounted using a GMA 340 unit rack. Figure 2-2 shows the GMA 340 unit rack. See Section 3.4 for installation instructions.

**NOTE**

Rear support is recommended to ensure a sturdy mount.

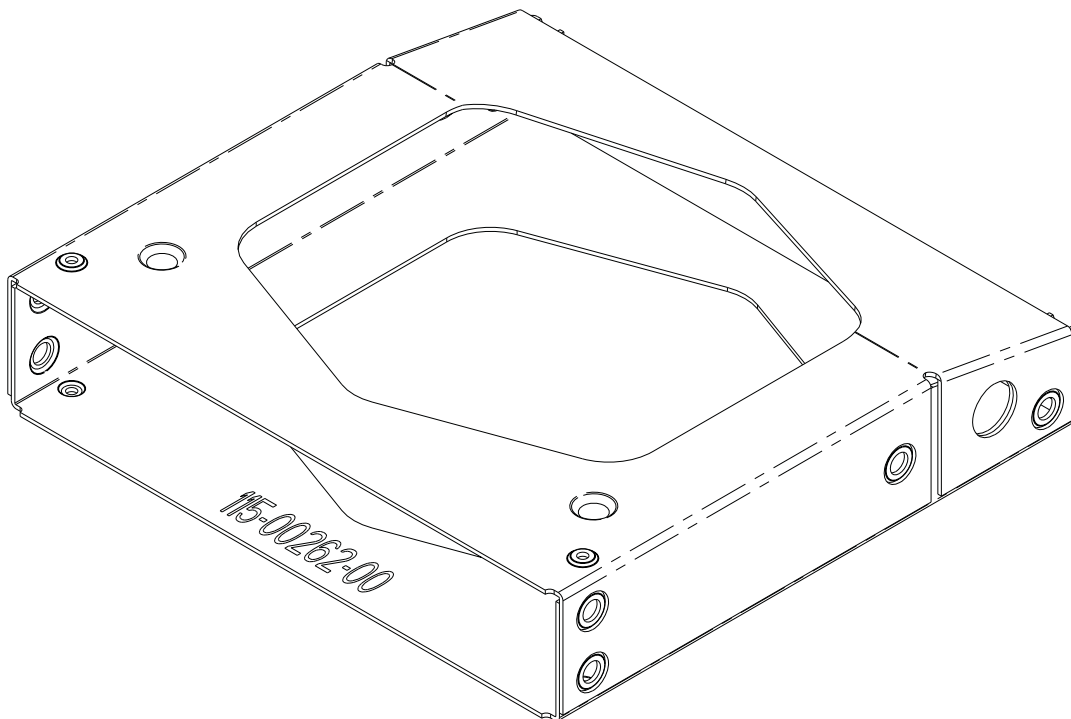

**Figure 2-2. GMA 340 Unit Rack (115-00262-00)**

## 3 INSTALLATION PROCEDURE

### 3.1 Unpacking Unit

Carefully unpack the equipment and make a visual inspection of the unit for evidence of damage incurred during shipment. If the unit is damaged, notify the carrier and file a claim. To justify a claim, save the original shipping container and all packing materials. Do not return the unit to Garmin until the carrier has authorized the claim.

Retain the original shipping containers for storage. If the original containers are not available, a separate cardboard container should be prepared that is large enough to accommodate sufficient packing material to prevent movement.

### 3.2 Electrical Connections

All electrical connections to the GMA 240 are made through two 44-pin D-subminiature connectors (see Figure 3-1). Section 4 defines the electrical characteristics of all input and output signals. Required connector and associated hardware are supplied in the connector kit (P/N 011-00652-00). See Appendix B for interconnect wiring diagrams.

Check wiring connections for errors before inserting the GMA 240 into the rack. Incorrect wiring could cause internal component damage.

**Table 3-1. Pin Contact Part Numbers**

Manufacturer	22-28 AWG
Garmin P/N	336-00021-00
Military P/N	M39029/58-360
AMP	204370-2
Positronic	MC8522D
ITT Cannon	030-2042-000

**Table 3-2. Recommended Crimp Tools**

Manufacturer	Hand Crimping Tool	High Density 20-28 AWG	
		Positioner	Insertion/Extraction Tool
Military P/N	M22520/2-01	M22520/2-09	M81969/1-04
Positronic	9507	9502-3	M81969/1-04
ITT Cannon	995-0001-584	995-0001-739	N/A
AMP	601966-1	601966-6	91067-1
Daniels	AFM8	K42	M81969/1-04
Astro	615717	615725	M81969/1-04

**NOTE**

1. Non-Garmin part numbers shown are not maintained by Garmin and consequently are subject to change without notice.
2. Extracting the #16, #18 and #20 contact requires that the expanded wire barrel be cut off from the contact. It may also be necessary to push the pin out from the face of the connector when using an extractor due to the absence of the wire. A new contact must be used when reassembling the connector.
3. For applications using 16 AWG wire, contact Garmin for information regarding connector crimp positioner tooling.

### 3.3 Audio Shield Termination

The audio shield wires should be terminated at the rear of the unit to the screws between J2401 and J2402 as shown in Figure 3-1.

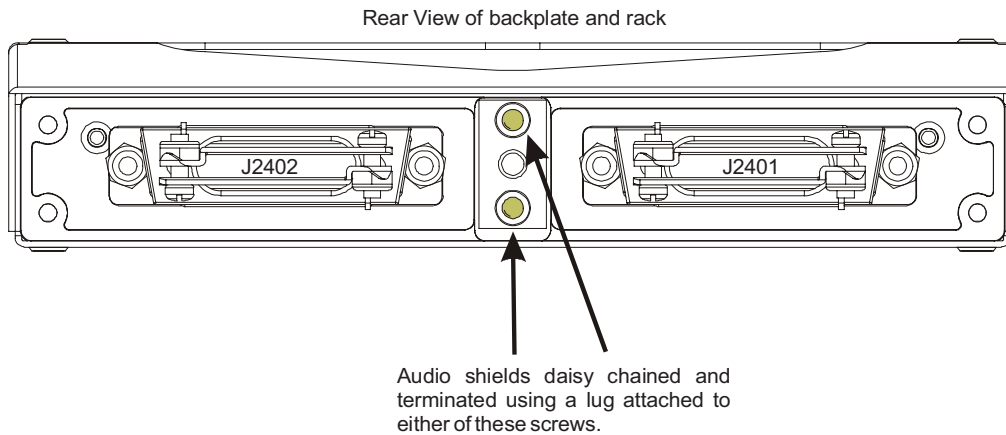

**Figure 3-1. Audio Shield Termination**

### 3.4 GMA 240 Installation

**NOTE**

Avoid installing the unit near heat sources. If this is not possible, ensure that additional cooling is provided. Allow adequate space for installation of cables and connectors. The installer will supply and fabricate all of the cables.

1. Assemble the connector/rack kit according to Tables 4-1, 4-2; and Figures B-1 and B-2. Install the rack assembly according to the dimensions given in Figures A-1 and A-3. Mounting brackets are not supplied due to the wide range of mounting configurations available. Suitable mounting brackets may be fabricated from sheet metal or angle stock. To ensure a sturdy mount, rear support for the unit should be provided.
2. Slide the unit into the rack until the jackscrew makes contact with the receptacle located in the back plate.
3. Insert a 3/32" Allen wrench into the jackscrew access hole on the faceplate.
4. Turn the Allen wrench clockwise until the unit is secured in the rack. Continue turning until tight, but do not over-tighten.

**CAUTION**

Do not use excessive force when inserting the GMA 240 into the rack. This may damage the connectors, unit, and/or unit rack. If heavy resistance is felt during installation, stop, and remove the GMA 240 and identify the source of resistance.

5. To remove the unit from the rack, turn the Allen wrench counterclockwise until it disengages from the rack.

---

## 3.5 Post Installation Checkout

### CAUTION

Check wiring connections for errors before inserting the GMA 240 into the rack. Incorrect wiring could cause internal component damage.

An in-aircraft checkout may be performed in the aircraft on the ramp with known good microphone, headset, and avionics receivers.

### 3.5.1 Lamp Test

1. Apply power to the unit by rotating the pilot intercom knob clockwise.
2. Verify that all annunciators on the front panel are illuminated during initial power up.

### 3.5.2 Failsafe Operation Check

1. Turn the unit off by rotating the pilot intercom knob fully counter clockwise.
2. Check the failsafe operation by exercising the COM 1 microphone, microphone key, and monitoring received COM 1 audio over the pilot headphone's left earpiece.
3. If installed, check that the failsafe warning is heard in the pilot headphone's left earpiece.
4. Turn the unit back on to continue testing.

### 3.5.3 Transceiver Operational Check

1. Perform a ramp test radio check by exercising the installed transceivers, microphone, microphone key, and audio over the headphone.
2. Verify that communications are loud and clear and PTT operation is correct.

### 3.5.4 Intercom System (ICS) Check

#### NOTE

Stereo headsets are recommended if stereo jacks are installed. Alternatively, the installation should employ stereo jacks with a mono/stereo switch that disconnects the audio panel's right channel output from the jack's ring contact when in mono mode. If a monaural headset is used in a stereo jack, the audio panel's right channel output is shorted to ground by the mono headset's plug. This causes excess power supply current to be drawn. While this does not damage the unit's output circuitry, prolonged periods (especially at high volume) may cause the internal power input fuse to open. This is because the unit is optimized for low-power operation in systems with limited power budgets. In the case of copilot/passenger positions wired in parallel, any stereo listener will lose right channel audio when another passenger plugs in a mono headset.

1. Set the intercom to the ALL mode [Pilot ISO LED off.]

- 
2. Plug in headsets at each ICS position.

**NOTE**

For helicopter operation using a two-stage Intercom/PTT switch, prior to using the keyed-intercom mode, the VOX level should be set by adjusting the VOX knob while the first detent is actuated and held.

3. Check Pilot and Copilot ICS positions for isolation and proper operation of volume and squelch controls.

### **3.5.5 Aircraft Receivers Check**

1. Select the audio source corresponding to each installed avionics unit and check for audio over the headsets.

### **3.5.6 Music System Check**

1. Set the intercom to the ALL mode [Pilot ISO LED off.]
2. Connect a stereo audio source to MUSIC 1 (ensure the front panel jack is empty and the music volume knob is not set to minimum). Verify that stereo audio is heard over all headset positions when MUSIC 1 is selected as the music source and MUSIC LED is on. Pull out on the right side small knob and verify that music volume adjustment is working properly.
3. Select an audio source to COM 1 and verify that the sound is muted by active COM 1 audio when RADIO music mute is selected and by intercom audio when ICS music mute is selected.
4. Connect a stereo music source to MUSIC 2. Verify that stereo audio is heard when MUSIC 2 is selected as the music source and MUSIC LED is on.
5. Connect a stereo audio source to the front panel jack. Verify that stereo audio is heard when MUSIC 1 is selected as the music source and MUSIC LED is on.

**CAUTION**

Be sure to check all aircraft control movements before flight is attempted to ensure that the wiring harness does not touch any moving part.

This completes the in-aircraft post installation checkout. Perform a flight test after installing the unit to ensure satisfactory performance of the audio functions.

## **3.6 CONFIGURATION ADJUSTMENTS**

Adjustment to the Volume and Squelch settings can be made to the GMA 240 through access holes in the unit's top cover. Refer to Section 2.3 for details.

## **3.7 CONTINUED AIRWORTHINESS**

Maintenance of the GMA 240 is "on condition" only. Refer to the GMA 240 Maintenance Manual (Garmin P/N 190-00917-02) as needed. Periodic maintenance of the GMA 240 is not required. Instructions for Continued Airworthiness (ICA) are not required for this product under 14 CFR Part 21 since the GMA 240 has received no FAA approval or endorsement.



## 4 SYSTEM INTERCONNECTS

### 4.1 Connector Description

The GMA 240 has two 44-pin connectors located at the rear of the unit designated J2401 and J2402 which are oriented as shown in Figure 4-1.

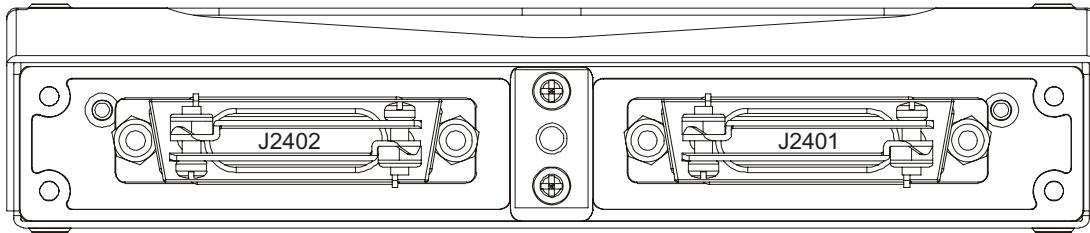

Figure 4-1. Rear View of Backplate and Rack

### 4.2 Pin List

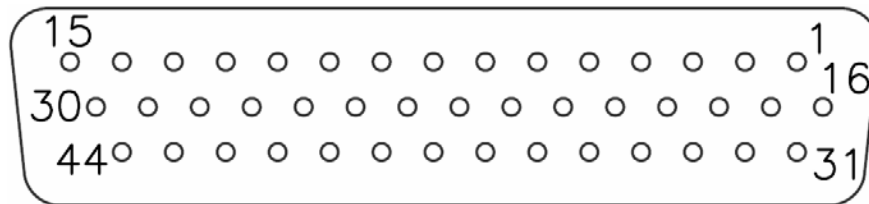

Figure 4-2. Rear Connectors J2401 & J2402, Viewed from Back of Unit

J2401 and J2402 pins are configured as shown in Figure 4-2. J2401 and J2402 pin assignments are given in Tables 4-1, 4-2, and Appendix B.

Following the pin assignment tables (Tables 4-1 & 4-2), additional tables group pin connections by function.

An asterisk (\*) following a signal name denotes that the signal is active low logic. Active low inputs are connected to ground to activate. Active low outputs sink current to ground when active.

## 4.2.1 P2401 Connector

**Table 4-1. J2401 Pin Assignments**

Pin	Pin Name	I/O
1	RESERVED	--
2	RESERVED	--
3	TEL AUDIO IN HI	IN
4	TEL AUDIO LO	--
5	TEL MIC AUDIO OUT HI	OUT
6	RESERVED	--
7	AUX2 AUDIO IN HI	IN
8	AUX2 AUDIO IN LO	--
9	COM 1 AUDIO IN HI	IN
10	COM 1 AUDIO LO	--
11	COM 1 MIC AUDIO OUT HI	OUT
12	COM 1 MIC KEY* OUT	OUT
13	COM 2 AUDIO IN HI	IN
14	COM 2 AUDIO LO	--
15	COM 2 MIC AUDIO OUT HI	OUT
16	MASQ INHIBIT* IN	IN
17	NAV 1 AUDIO IN HI	IN
18	NAV 1 AUDIO IN LO	--
19	NAV 2 AUDIO IN HI	IN
20	NAV 2 AUDIO IN LO	--
21	AUX1 AUDIO IN HI	IN
22	AUX1 AUDIO IN LO	--
23	RESERVED	--
24	RESERVED	--
25	RESERVED	--
26	RESERVED	--
27	RESERVED	--
28	RESERVED	--
29	CREW ISO* IN	IN
30	COM 2 MIC KEY* OUT	OUT
31	ALERT 1 AUDIO IN HI	IN
32	ALERT 1 AUDIO IN LO	--
33	PILOT MIC AUDIO IN HI	IN
34	PILOT MIC KEY* IN	IN
35	PILOT MIC AUDIO IN LO	--
36	RESERVED	--
37	RESERVED	--
38	RESERVED	--
39	RESERVED	--
40	PASS HEADSET AUDIO OUT LEFT	OUT
41	PASS HEADSET AUDIO OUT RIGHT	OUT
42	PASS HEADSET AUDIO OUT LO	--
43	ALERT 2,3 AUDIO IN LO	--
44	ALERT 2 AUDIO IN HI	IN

\* Denotes Active Low (Inputs: ground to activate; Outputs: grounded when active)

## 4.2.2 J2402 Connector

**Table 4-2. J2402 Pin Assignments**

Pin	Pin Name	I/O
1	PILOT HEADSET AUDIO OUT LO	--
2	COPILOT HEADSET AUDIO OUT LO	--
3	COPILOT HEADSET AUDIO OUT LEFT	OUT
4	COPILOT HEADSET AUDIO OUT RIGHT	OUT
5	LIGHTING BUS 14V LO/28V LO	--
6	LIGHTING BUS 14V HI/28V LO	IN
7	LIGHTING BUS 14V HI/28V HI	IN
8	AIRCRAFT POWER	IN
9	AIRCRAFT POWER	IN
10	AIRCRAFT GROUND	--
11	AIRCRAFT GROUND	--
12	RESERVED	--
13	PILOT ISO MUSIC* IN	IN
14	PILOT ISO MUSIC* RETURN	--
15	ALERT 3 AUDIO IN HI	IN
16	PILOT HEADSET AUDIO OUT LEFT	OUT
17	RESERVED	--
18	RESERVED	--
19	BUTTON PRESS TONE ENABLE* IN	IN
20	COM SWAP* IN	IN
21	COM SWAP* IN RETURN	--
22	RESERVED	--
23	MUSIC 1 IN LEFT	IN
24	MUSIC 1 IN RIGHT	IN
25	MUSIC 1 IN LO	--
26	MUSIC 2 IN LEFT	IN
27	MUSIC 2 IN RIGHT	IN
28	MUSIC 2 IN LO	--
29	FAILSAFE WARN AUDIO IN HI	IN
30	MUTE ON COM TX* IN	IN
31	PILOT HEADSET AUDIO OUT RIGHT	OUT
32	COPILOT MIC AUDIO IN HI	IN
33	COPILOT MIC KEY* IN	IN
34	COPILOT MIC AUDIO IN LO	--
35	PASS 1 MIC AUDIO IN HI	IN
36	PASS 1 MIC AUDIO IN LO	--
37	PASS 2 MIC AUDIO IN HI	IN
38	PASS 2 MIC AUDIO IN LO	--
39	RESERVED	--
40	RESERVED	--
41	RESERVED	--
42	RESERVED	--
43	RESERVED	--
44	RESERVED	--

\* Denotes Active Low (Inputs: ground to activate; Outputs: grounded when active)

### 4.2.3 P2403 Connector (front panel 2.5 mm mini-jack)



Figure 4-2. 2.5 mm plug used with P2403

Pin	Pin Name	I/O
TIP	MUSIC 1 LEFT IN/TEL MIC OUT HI	IN/OUT
RING	MUSIC 1 RIGHT IN/TEL AUDIO IN HI	IN
SLEEVE	MUSIC 1 LO IN/TEL AUDIO LO	--

## 4.3 Aircraft Power and Lighting

### 4.3.1 Aircraft Power

The GMA 240 has four inputs for aircraft power bus inputs of 14/28Vdc.

Pin	Connector	Pin Name	I/O
8	P2402	AIRCRAFT POWER	IN
9	P2402	AIRCRAFT POWER	IN
10	P2402	POWER GROUND	--
11	P2402	POWER GROUND	--

### 4.3.2 Lighting Bus

The GMA 240 can be configured to track a 14 or 28 Vdc lighting bus using these inputs. Refer to Figure B-1 for lighting interconnections.

Pin	Connector	Pin Name	I/O
5	P2402	LIGHTING BUS 14V LO/28V LO	--
6	P2402	LIGHTING BUS 14V HI/28V LO	IN
7	P2402	LIGHTING BUS 14V HI/28V HI	IN

## 4.4 Configuration Pins

### 4.4.1 External Configuration Pins

The following pins may be used to change the configuration of the installation as described.

Pin	Connector	Pin Name	Description
16	P2401	MASQ INHIBIT* IN	Ground to disable Master Avionics Squelch circuitry. This will cause alerts and selected radios to be heard at all times without needing to exceed the mute threshold. This causes an increase in background noise from the inputs during quiet output.
29	P2401	CREW ISO* IN	Ground to configure the unit for CREW ICS isolation. In this configuration, the copilot headset jack should be wired in parallel with the pilot headset output. The mics are wired as normal. In this mode, when the PILOT ISO button is selected, the pilot and copilot will hear each other, but will be intercom isolated from the passengers.
13	P2402	PILOT ISO MUSIC* IN	Ground to allow Music audio to be heard by the pilot during pilot isolate mode.
19	P2402	BUTTON PRESS TONE ENABLE* IN	Ground to enable beep tone annunciation of button presses
30	P2402	MUTE ON COM TX* IN	Ground to enable muting of other selected radios during mic selected COM transmission (mic-selected COM is still heard, but not other selected radios)

\* Denotes Active Low (Ground to activate)

## 4.5 Audio Inputs/Outputs and Mic Keys

### 4.5.1 Mic Audio Inputs and Mic Keys

Pin	Connector	Pin Name	Description	I/O
34	P2401	PILOT MIC KEY* IN	Enables respective MIC audio into the selected transceiver unit	IN
33	P2402	COPILOT MIC KEY* IN		IN
33	P2401	PILOT MIC AUDIO IN HI	Pilot Mic audio input and ground reference	IN
35	P2401	PILOT MIC IN LO		--
32	P2402	COPILOT MIC AUDIO IN HI	Copilot Mic audio input and ground reference	IN
34	P2402	COPILOT MIC IN LO		--
35	P2402	PASS 1 MIC AUDIO IN HI	Passenger 1 Mic audio and ground reference	IN
36	P2402	PASS 1 MIC AUDIO IN LO		--
37	P2402	PASS 2 MIC AUDIO IN HI	Passenger 2 Mic audio and ground reference	IN
38	P2402	PASS 2 MIC AUDIO IN LO		--

\*Denotes Active Low (Ground to activate)

### 4.5.2 Intercom Key Inputs (if configured)

These inputs only perform the described ICS KEY function if the audio panel has been configured for KEYED ICS by configuration jumper settings (see Section 2.3.1). For this configuration, intercom squelch levels should be set fully CCW (live MIC) because the MIC signal must also break the VOX threshold to be heard.

Pin	Connector	Pin Name	Description
17	P2402	PILOT ICS KEY* IN	Enables respective mic audio to be heard in the intercom
36	P2401	COPILOT ICS KEY* IN	
37	P2401	PASSENGER ICS KEY* IN	

\*Denotes Active Low (Ground to activate)

### 4.5.3 COM Audio and Mic Keys

Pin	Connector	Pin Name	Description	I/O
12	P2401	COM 1 MIC KEY* OUT	Enables transmission on the respective transceiver unit	OUT
30	P2401	COM 2 MIC KEY* OUT		OUT
9	P2401	COM 1 AUDIO IN HI	COM 1 Audio Input	IN
11	P2401	COM 1 MIC AUDIO OUT HI	COM 1 Audio Output	OUT
10	P2401	COM 1 AUDIO LO	Ground Reference for COM 1	--
13	P2401	COM 2 AUDIO IN HI	COM 2 Audio Input	IN
15	P2401	COM 2 MIC AUDIO OUT HI	COM 2 Audio Output	OUT
14	P2401	COM 2 AUDIO LO	Ground Reference for COM 2	--

\* Denotes Active Low (Sinks current to ground when active)

#### 4.5.4 Alert Audio I/O

Pin	Connector	Pin Name	Description	I/O
31	P2401	ALERT 1 AUDIO IN HI	Alert 1 Audio Input	IN
32	P2401	ALERT 1 AUDIO IN LO	Ground Reference for Alert 1	--
44	P2401	ALERT 2 AUDIO IN HI	Alert 2 Audio Input	IN
15	P2402	ALERT 3 AUDIO IN HI	Alert 3 Audio Input	IN
43	P2401	ALERT 2,3 AUDIO IN LO	Ground Reference for Alert 2 & 3	--

#### 4.5.5 AUX and NAV Audio Inputs

Pin	Connector	Pin Name	Description	I/O
21	P2401	AUX1 AUDIO IN HI	AUX1 Audio Input	IN
22	P2401	AUX1 AUDIO IN LO	Ground Reference for AUX1 Input	--
7	P2401	AUX2 AUDIO IN HI	AUX2 Audio Input	IN
8	P2401	AUX2 AUDIO IN LO	Ground Reference for AUX2 Input	--
17	P2401	NAV 1 AUDIO IN HI	NAV 1 Audio Input	IN
18	P2401	NAV 1 AUDIO IN LO	NAV 1 Ground Reference	--
19	P2401	NAV 2 AUDIO IN HI	NAV 2 Audio Input	IN
20	P2401	NAV 2 AUDIO IN LO	NAV 2 Ground Reference	--

#### 4.5.6 Failsafe Warning Audio

Pin	Connector	Pin Name	Description	I/O
29	P2402	FAILSAFE WARN AUDIO IN HI	Failsafe Warning Audio Input	IN

#### 4.5.7 Music Inputs

Pin	Connector	Pin Name	Description	I/O
23	P2402	MUSIC 1 IN LEFT	Music 1 Input	IN
24	P2402	MUSIC 1 IN RIGHT		IN
25	P2402	MUSIC 1 IN LO	Ground Reference for Music 1	--
26	P2402	MUSIC 2 IN LEFT	Music 2 Input	IN
27	P2402	MUSIC 2 IN RIGHT		IN
28	P2402	MUSIC 2 IN LO	Ground Reference for Music 2	--

#### 4.5.8 Tel Audio I/O

Pin	Connector	Pin Name	Description	I/O
3	P2401	TEL AUDIO IN HI	Telephone Audio Input	IN
4	P2401	TEL AUDIO LO	Ground Reference for Telephone	--
5	P2401	TEL MIC AUDIO OUT HI	TEL MIC Audio Output	OUT

#### 4.5.9 Headset Outputs

Pin	Connector	Pin Name	Description	I/O
16	P2402	PILOT HEADSET AUDIO OUT LEFT	Pilot Headset Audio Output	OUT
31	P2402	PILOT HEADSET AUDIO OUT RIGHT		OUT
1	P2402	PILOT HEADSET AUDIO OUT LO		--
3	P2402	COPILOT HEADSET AUDIO OUT LEFT	Copilot Headset Audio Output	OUT
4	P2402	COPILOT HEADSET AUDIO OUT RIGHT		OUT
2	P2402	COPILOT HEADSET AUDIO OUT LO		--
40	P2401	PASS HEADSET AUDIO OUT LEFT	Passenger Headset Audio Output	OUT
41	P2401	PASS HEADSET AUDIO OUT RIGHT		OUT
42	P2401	PASS HEADSET AUDIO OUT LO		--

**NOTE**

Copilot and Passenger headset outputs are internally the same connection. Separate Passenger headset output pins are provided for wiring convenience and GMA 340 pin compatibility.

**NOTE**

For CREW ISO configuration, the copilot's headphone jack should be wired in parallel with the pilot jack to the Pilot headset output pins. Passengers may be connected to either the copilot or passenger pins.

#### 4.5.10 COM Swap

Pin	Connector	Pin Name	Description	I/O
20	P2402	COM SWAP* IN	Ground Through a Momentary PB Switch to Swap Active COM (COM 1 or COM 2)	IN
21	P2402	COM SWAP RETURN	Return Path for PB Switch	--



APPENDIX A OUTLINE AND INSTALLATION DRAWINGS

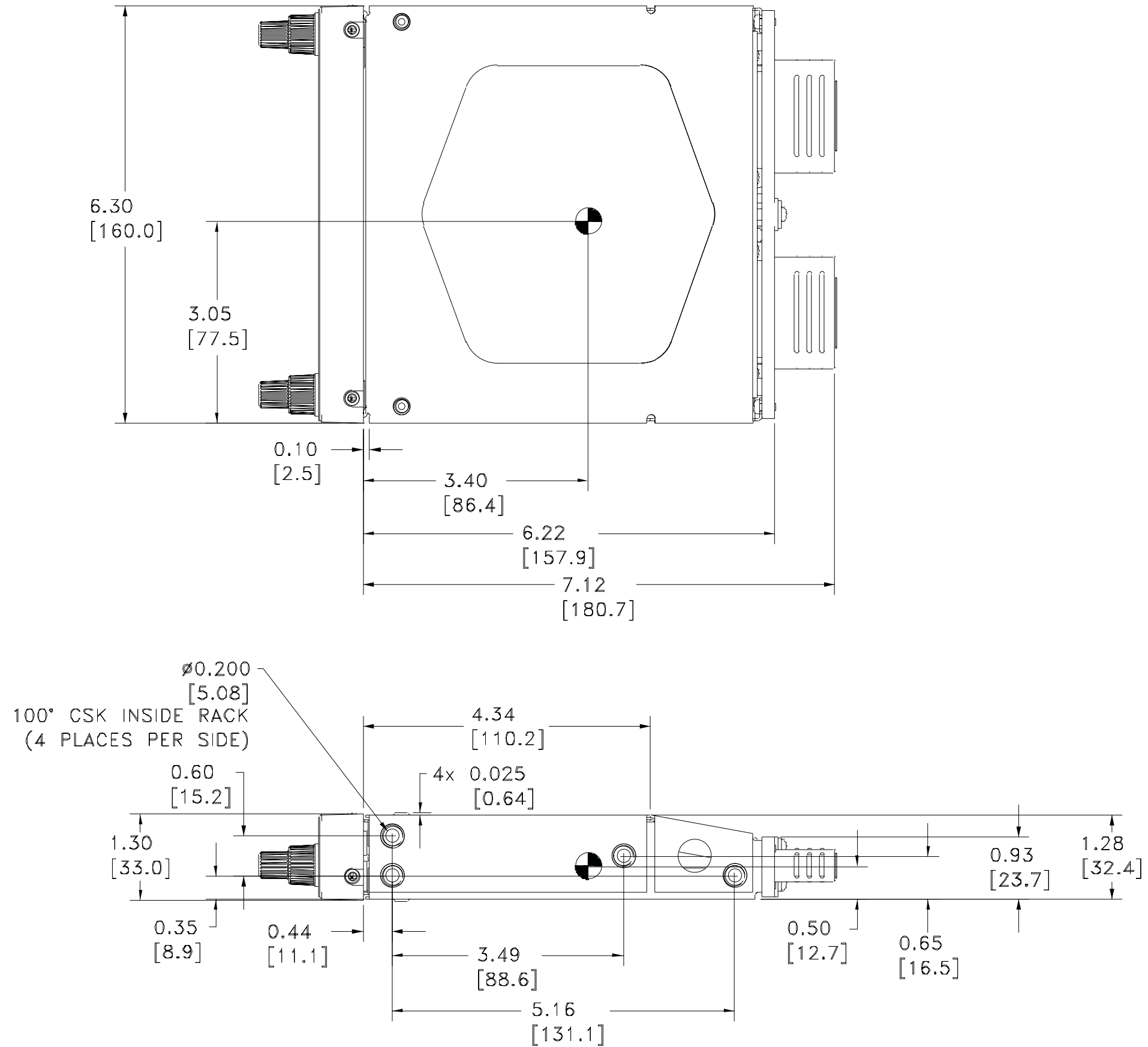
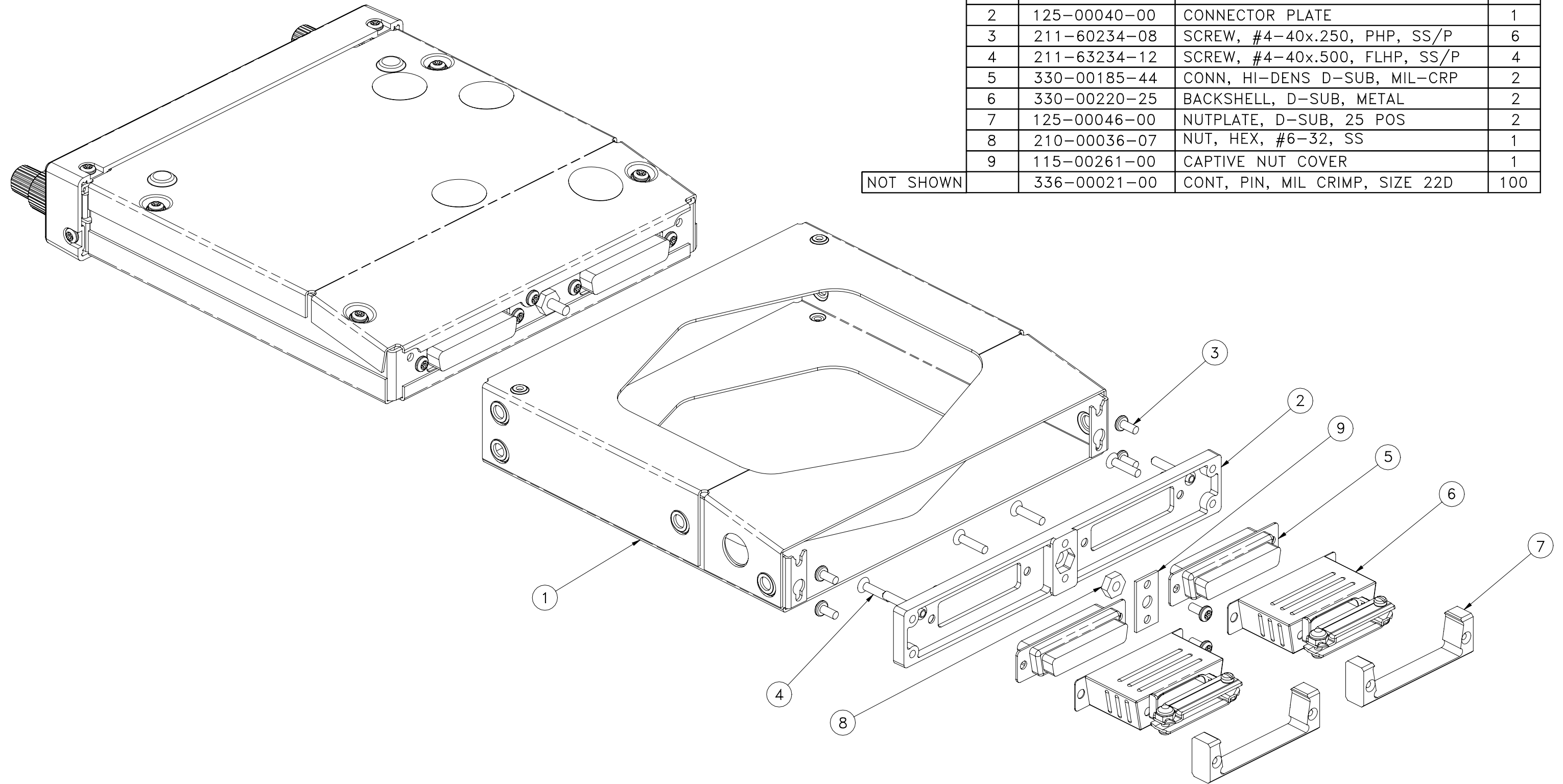

Figure A-1. GMA 240 Outline Drawing

**APPENDIX A OUTLINE AND INSTALLATION DRAWINGS**

011-00403-00 CONNECTOR/RACK KIT			
ITEM	PART NUMBER	DESCRIPTION	QTY
1	115-00262-00	INSTALL RACK	1
2	125-00040-00	CONNECTOR PLATE	1
3	211-60234-08	SCREW, #4-40x.250, PHP, SS/P	6
4	211-63234-12	SCREW, #4-40x.500, FLHP, SS/P	4
5	330-00185-44	CONN, HI-DENS D-SUB, MIL-CRP	2
6	330-00220-25	BACKSHELL, D-SUB, METAL	2
7	125-00046-00	NUTPLATE, D-SUB, 25 POS	2
8	210-00036-07	NUT, HEX, #6-32, SS	1
9	115-00261-00	CAPTIVE NUT COVER	1
NOT SHOWN	336-00021-00	CONT, PIN, MIL CRIMP, SIZE 22D	100

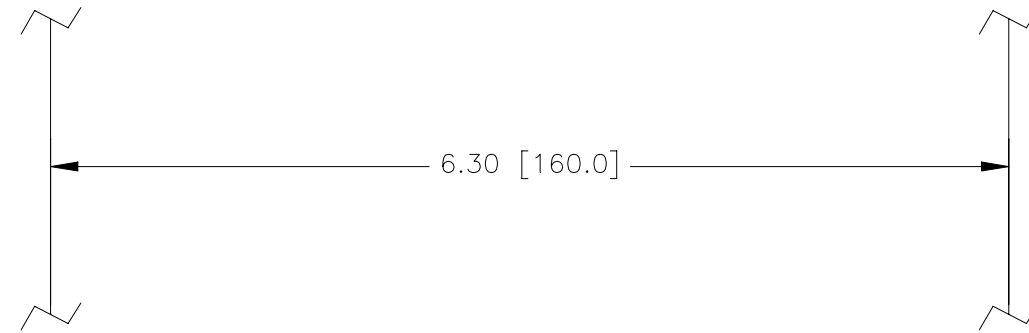

**Figure A-2. GMA 240 Connector/Rack Assembly Drawing**

**APPENDIX A OUTLINE AND INSTALLATION DRAWINGS**

OPTION 1:

STACK CUTOUT (RACK INSTALLED FROM FRONT OF AIRCRAFT PANEL)



OPTION 2:

RADIO CUTOUT (RACK INSTALLED FROM FRONT OF AIRCRAFT PANEL)



OPTION 3:

RADIO CUTOUT (RACK INSTALLED FROM BACK OF AIRCRAFT PANEL ONLY)  
MAXIMUM AIRCRAFT PANEL THICKNESS IS .125 INCH [3.2 mm]



NOTES:

1. DIMENSIONS: INCH [mm].
2. IF THE FRONT LIP OF THE MOUNTING RACK IS BEHIND THE SURFACE OF THE AIRCRAFT PANEL, THE UNIT CONNECTORS MAY NOT FULLY ENGAGE.

**Figure A-3. GMA 240 Recommended Panel Cutout Dimensions**

APPENDIX B INTERCONNECT DRAWINGS

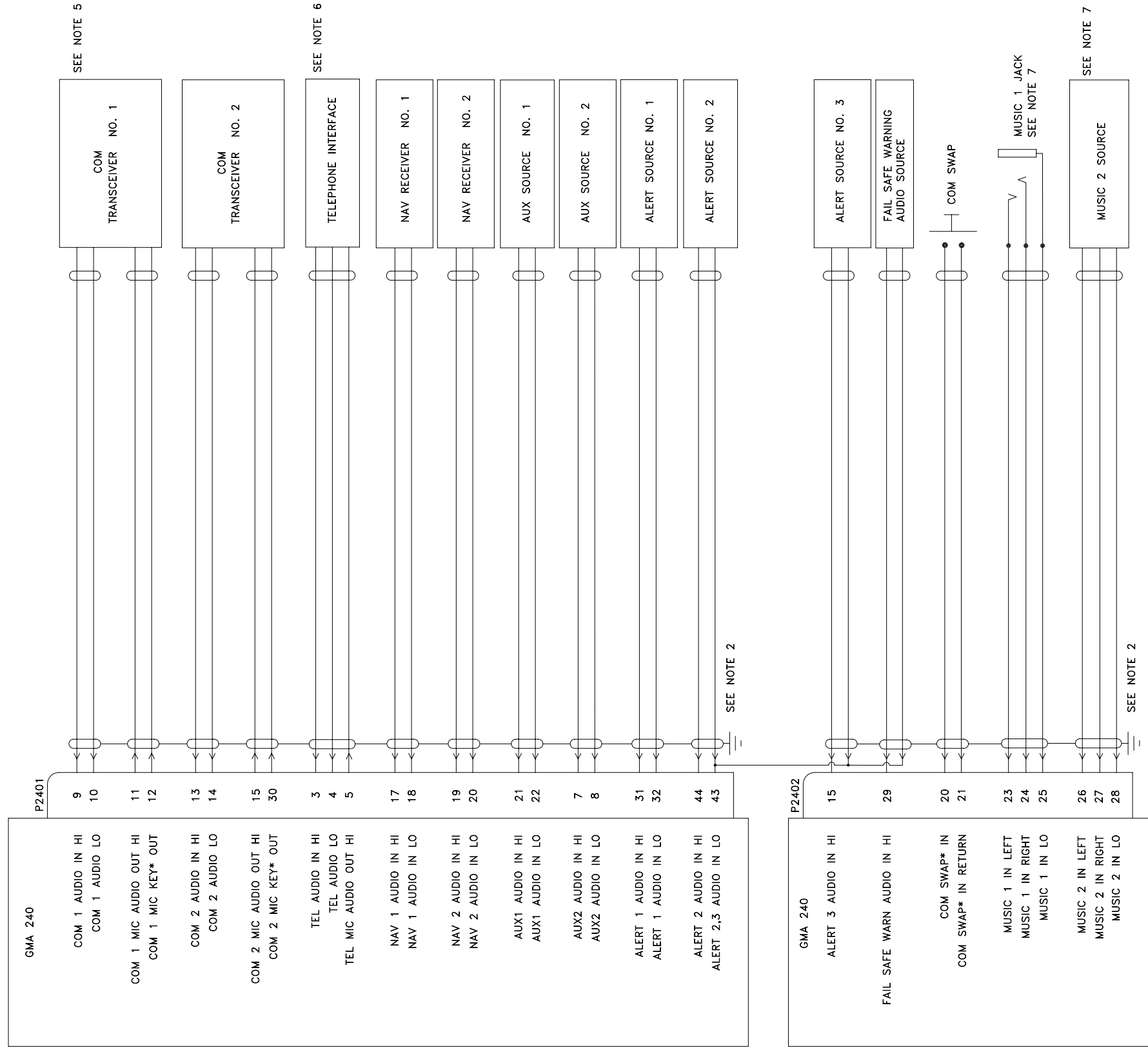

- NOTES:
- ALL WIRE SHOULD BE 24 AWG OR LARGER TEFLON INSULATED.
  - UNLESS OTHERWISE INDICATED, ALL SHIELDS MUST BE TERMINATED AT THE GMA 240 END ONLY. DAISY CHAIN SHIELDS TO A SUITABLE RING TERMINAL AND ATTACH TO CENTER GROUNDING LUGS IN BACK OF CONNECTOR BACKPLATE.
  - ALL AUDIO JACKS USED IN THE INSTALLATION MUST BE ELECTRICALLY ISOLATED FROM CHASSIS TO AVOID GROUND LOOPS. THIS MAY REQUIRE THE USE OF INSULATION WASHERS WHEN MOUNTING JACKS. USE OF ISOLATED TYPE JACKS IS HIGHLY RECOMMENDED TO SIMPLIFY INSTALLATION.
  - SYMBOL DESIGNATIONS
    - TWISTED SHIELDED PAIR SHIELD TERMINATED TO GROUND
    - TWISTED SHIELDED 3 CONDUCTOR SHIELD TERMINATED TO GROUND
    - WIRE SPLICE CONNECTION
    - PUSH BUTTON SWITCH, SINGLE POLE
    - TWISTED SHIELDED PAIR SHIELD FLOATS
    - TWISTED SHIELDED 3 CONDUCTOR SHIELD FLOATS
    - UNIT GROUND
  - TRANSCIVER INTERFACES CAN ALSO BE WIRED THROUGH SUITABLE JACKS AND CABLES TO HANDHELD COMS THAT HAVE HEADSET INTERFACE CAPABILITY. THE HANDHELD'S HEADSET OUTPUT (LEFT CHANNEL ONLY IF STEREO) CONNECTS TO THE GMA'S COM AUDIO IN HI AND COM AUDIO LO PINS, THE HANDHELD'S MIC INPUT CONNECTS TO GMA'S COM MIC AUDIO OUT HI AND COM AUDIO LO PINS, AND THE HANDHELD'S PTT KEY CONNECTS TO GMA'S COM MIC KEY\* OUT. SEE THE TRANSCIVER'S INSTRUCTION MANUAL.
  - THE TELEPHONE INTERFACE MAY BE WIRED TO A FIXED MOUNTED TELEPHONE SOURCE (SHOWN) OR TO A SUITABLE JACK FOR A PORTABLE TELEPHONE.
  - BOTH MUSIC INPUTS MAY BE WIRED TO EITHER AN EXTERNAL JACK (AS SHOWN FOR MUSIC 1) OR A FIXED MOUNTED MUSIC SOURCE (AS SHOWN FOR MUSIC 2).

Figure B-1. GMA 240 Interconnect Drawing (page 1 of 3)

APPENDIX B INTERCONNECT DRAWINGS

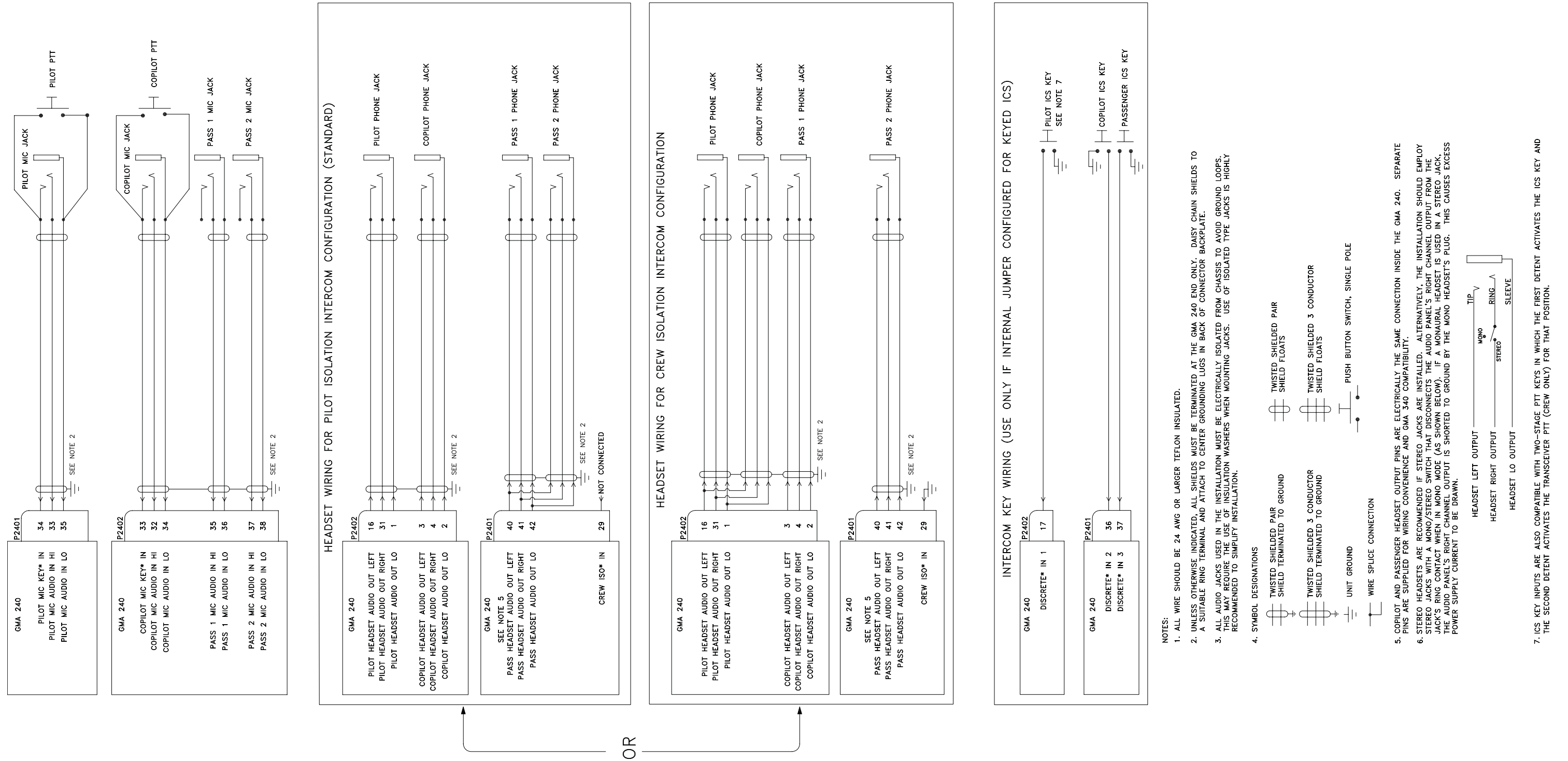
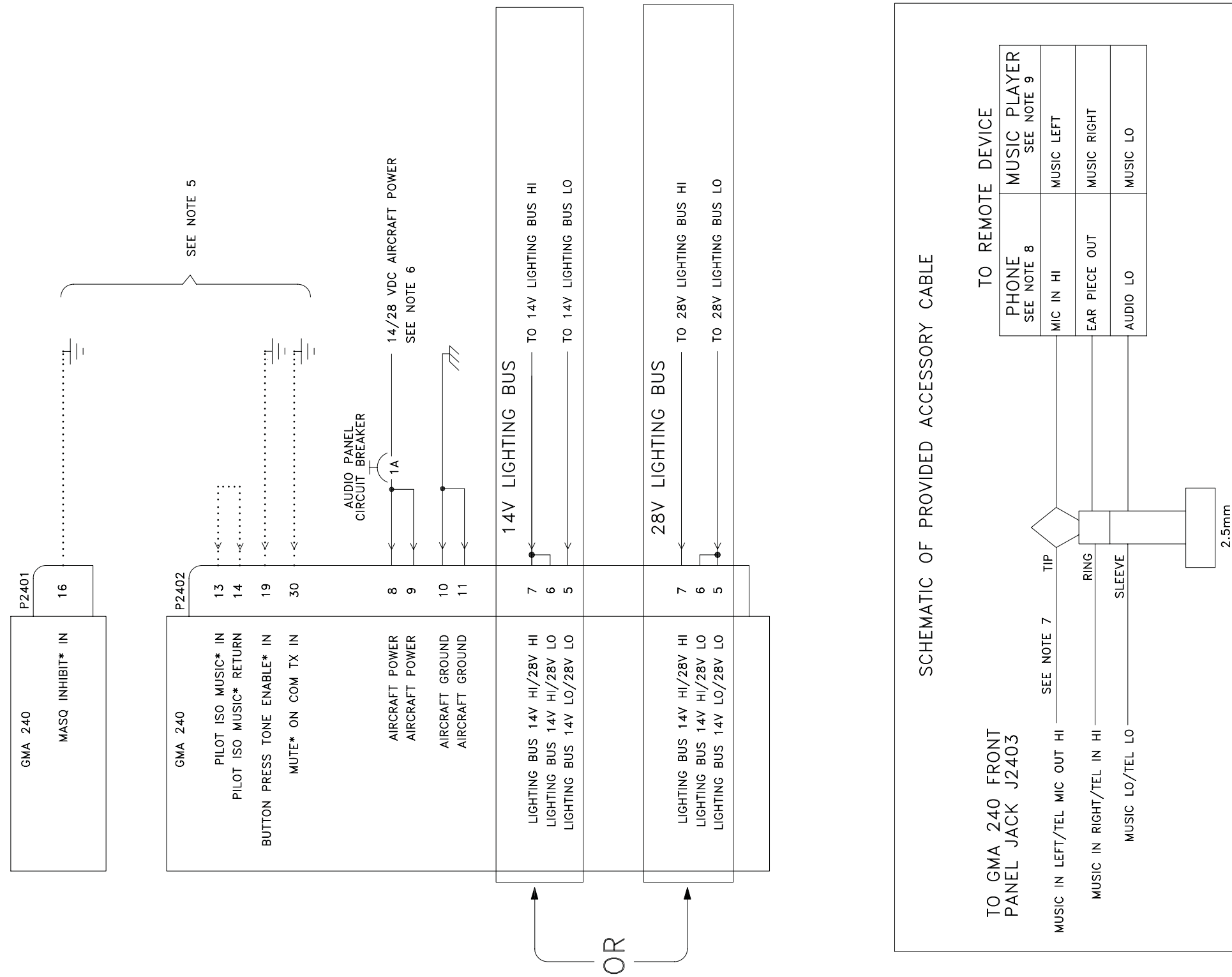

Figure B-1. GMA 240 Interconnect Drawing (page 2 of 3)



NOTES:





1. ALL WIRE SHOULD BE 24 AWG OR LARGER TEFLON INSULATED.
2. UNLESS OTHERWISE INDICATED, ALL SHIELDS MUST BE TERMINATED AT THE GMA 240 END ONLY. DAISY CHAIN SHIELDS TO A SUITABLE RING TERMINAL AND ATTACH TO CENTER GROUNDING LUGS IN BACK OF CONNECTOR BACKPLATE.
3. ALL AUDIO JACKS USED IN THE INSTALLATION MUST BE ELECTRICALLY ISOLATED FROM CHASSIS TO AVOID GROUND LOOPS. THIS MAY REQUIRE THE USE OF INSULATION WASHERS WHEN MOUNTING JACKS. USE OF ISOLATED TYPE JACKS IS HIGHLY RECOMMENDED TO SIMPLIFY INSTALLATION.
4. SYMBOL DESIGNATIONS  
 WIRE SPLICE CONNECTION  
 CIRCUIT BREAKER  
 AIRFRAME GROUND  
 UNIT GROUND  
 ..... CONFIGURATION WIRING CONNECTION
5. CONFIGURATION PINS ARE GROUNDED TO INITIATE THE LABELED FUNCTION. OPTIONALLY, THEY MAY BE CONNECTED THROUGH A SWITCH TO GROUND IF TOGGING IS DESIRED. SEE INSTALLATION MANUAL TEXT FOR DETAILS.
6. IF A DEDICATED CIRCUIT BREAKER IS DESIRED, 1 A RATING IS RECOMMENDED. AIRCRAFT GROUND SHOULD BE CONNECTED DIRECTLY TO THE AIRFRAME USING MINIMAL WIRE LENGTH.
7. THE PROVIDED FRONT PANEL JACK AUDIO CABLES ARE COMPATIBLE WITH MANY PHONES AND PORTABLE AUDIO PLAYERS. SOME DEVICES HAVE OTHER CONNECTOR STYLES.
8. IF THE PHONE HAS A 2.5 MM JACK, THE PROVIDED 2.5 MM CABLE IS THE MOST COMMON CONFIGURATION. SOME PHONES WITH 2.5 MM JACKS USE CROSSOVER CABLES THAT SWAP THE MIC AND EARPIECE CONNECTION. IF THIS CONVERSION IS NECESSARY, OR IF A DIFFERENT STYLE CONNECTOR IS NEEDED TO INTERFACE TO THE PHONE, USE THE ABOVE CONNECTION DIAGRAM AS A GUIDE FOR HOW THE PROVIDED CABLE SHOULD BE MODIFIED. ALSO CONSIDER CHECKING WITH THE PHONE MANUFACTURER OR ACCESSORY PROVIDER TO SEE IF A SUITABLE ADAPTOR CABLE IS COMMERCIALY AVAILABLE.
9. FOR AUDIO PLAYERS, THE PROVIDED CABLES ARE STANDARD FOR DEVICES THAT USE STEREO AUDIO JACKS. SOME DEVICES USE SPECIAL CONNECTOR STYLES. IF A DIFFERENT STYLE CONNECTOR IS NEEDED TO INTERFACE TO THE AUDIO PLAYER, USE THE ABOVE CONNECTION DIAGRAM AS A GUIDE FOR HOW THE PROVIDED CABLE SHOULD BE MODIFIED. ALSO CONSIDER CHECKING WITH THE DEVICE MANUFACTURER OR ACCESSORY PROVIDER TO SEE IF A SUITABLE ADAPTOR CABLE IS COMMERCIALY AVAILABLE.

Figure B-1. GMA 240 Interconnect Drawing (page 3 of 3)

### GMA240 J2401

15 COM 2 MIC AUDIO OUT HI	14 COM 2 AUDIO LO	13 COM 2 AUDIO IN HI	12 COM 1 MIC KEY* OUT	11 COM 1 MIC AUDIO OUT HI	10 COM 1 AUDIO LO	9 COM 1 AUDIO IN HI	8 AUX2 AUDIO IN LO	7 AUX2 AUDIO IN HI	6 RESERVED	5 TEL MIC AUDIO OUT HI	4 TEL AUDIO LO	3 TEL AUDIO IN HI	2 RESERVED	1 RESERVED
30 COM 2 MIC KEY* OUT	29 CREW ISO* IN	28 RESERVED	27 RESERVED	26 RESERVED	25 RESERVED	24 RESERVED	23 RESERVED	22 AUX1 AUDIO IN LO	21 AUX1 AUDIO IN HI	20 NAV 2 AUDIO IN LO	19 NAV 2 AUDIO IN HI	18 NAV 1 AUDIO IN LO	17 NAV 1 AUDIO IN HI	16 MASQ INHIBIT* IN
44 ALERT 2 AUDIO IN HI	43 ALERT 2,3 AUDIO IN LO	42 PASS HEADSET AUDIO OUT LO	41 PASS HEADSET AUDIO OUT RIGHT	40 PASS HEADSET AUDIO OUT LEFT	39 RESERVED	38 RESERVED	37 RESERVED	36 RESERVED	35 PILOT MIC AUDIO IN LO	34 PILOT MIC KEY* IN	33 PILOT MIC AUDIO IN HI	32 ALERT 1 AUDIO IN LO	31 ALERT 1 AUDIO IN HI	

### GMA240 J2402

15 ALERT 3 AUDIO IN HI	14 PILOT ISO MUSIC* RETURN	13 PILOT ISO MUSIC* IN	12 RESERVED	11 AIRCRAFT GROUND	10 AIRCRAFT GROUND	9 AIRCRAFT POWER	8 AIRCRAFT POWER	7 LIGHTING BUS 14V HI/28V HI	6 LIGHTING BUS 14V HI/28V LO	5 LIGHTING BUS 14V LO/28V LO	4 COPILOT HEADSET AUDIO OUT RIGHT	3 COPILOT HEADSET AUDIO OUT LEFT	2 COPILOT HEADSET AUDIO OUT LO	1 PILOT HEADSET AUDIO OUT LO
30 MUTE* ON COM TX IN	29 FAILSAFE WARN AUDIO IN HI	28 MUSIC 2 IN LO	27 MUSIC 2 IN RIGHT	26 MUSIC 2 IN LEFT	25 MUSIC 1 IN LO	24 MUSIC 1 IN RIGHT	23 MUSIC 1 IN LEFT	22 RESERVED	21 COM SWAP* IN RETURN	20 COM SWAP* IN	19 BUTTON PRESS TONE ENABLE* IN	18 RESERVED	17 RESERVED	16 PILOT HEADSET AUDIO OUT LEFT
44 RESERVED	43 RESERVED	42 RESERVED	41 RESERVED	40 RESERVED	39 RESERVED	38 PASS 2 MIC AUDIO IN LO	37 PASS 2 MIC AUDIO IN HI	36 PASS 1 MIC AUDIO IN LO	35 PASS 1 MIC AUDIO IN HI	34 COPILOT MIC AUDIO IN LO	33 COPILOT MIC KEY* IN	32 COPILOT MIC AUDIO IN HI	31 PILOT HEADSET AUDIO OUT RIGHT	

Figure B-2. GMA 240, J2401 & J2402 Connector Layout Drawing

### Top of Main Board

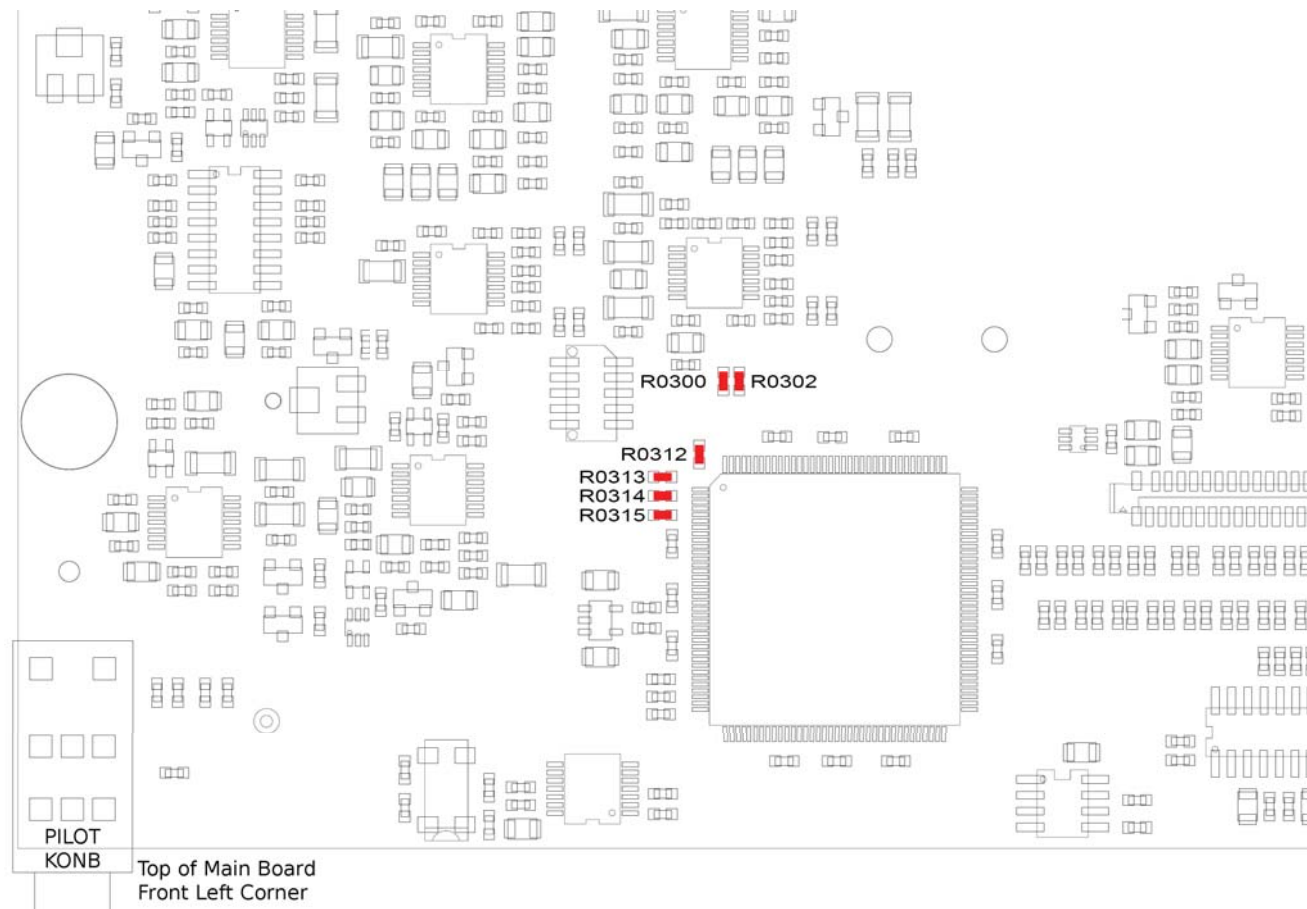

### Bottom of Main Board

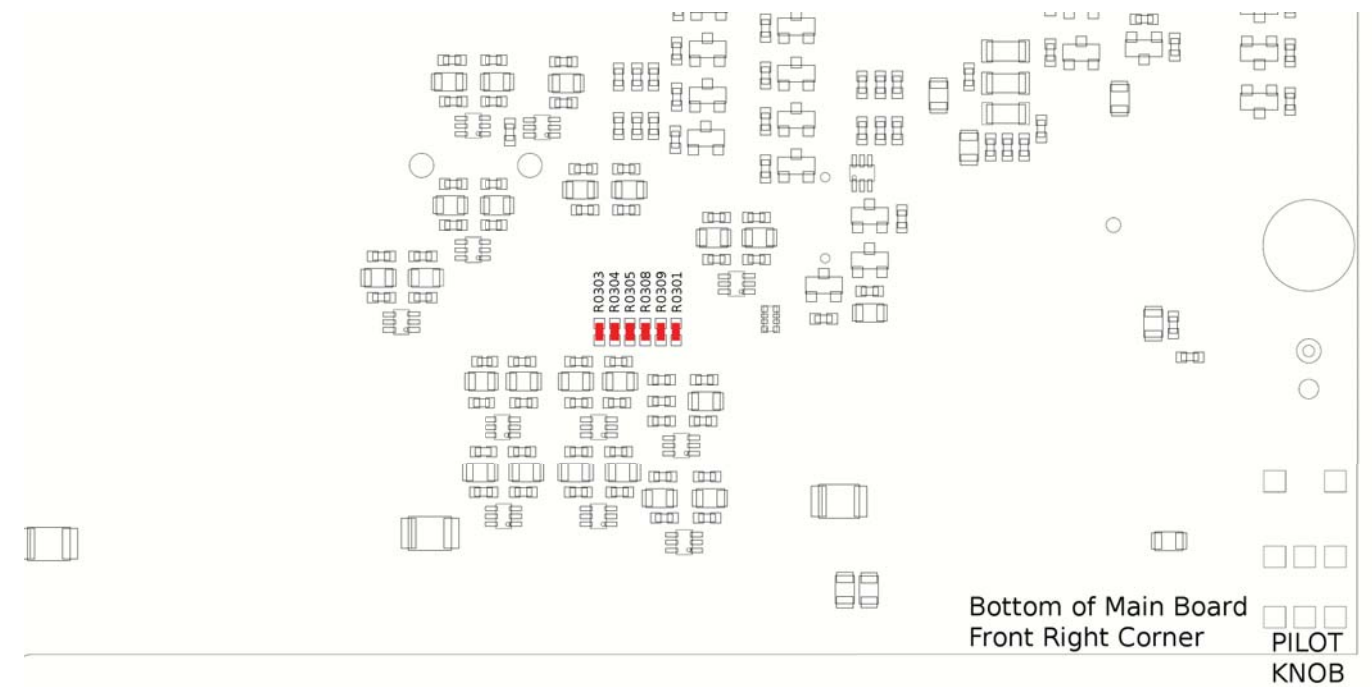

Figure C-1. GMA 240, Internal Configuration Jumper Layout Drawing



## Free Manuals Download Website

<http://myh66.com>

<http://usermanuals.us>

<http://www.somanuals.com>

<http://www.4manuals.cc>

<http://www.manual-lib.com>

<http://www.404manual.com>

<http://www.luxmanual.com>

<http://aubethermostatmanual.com>

Golf course search by state

<http://golfingnear.com>

Email search by domain

<http://emailbydomain.com>

Auto manuals search

<http://auto.somanuals.com>

TV manuals search

<http://tv.somanuals.com>