

## Corporate Headquarters

### **GarrettCom, Inc.**

47823 Westinghouse Drive

Fremont, CA 94539

**Phone (510) 438-9071**

Fax (510) 438-9072

Website: <http://www.GarrettCom.com>

**email [support@garrettcom.com](mailto:support@garrettcom.com)**



# Magnum 6K32 Managed Switch



## Hardware

## Installation and User Guide

# Magnum™ 6K32

## Managed Switch

### Hardware

## Installation and User Guide

Part #: 84-00138 (Rev. A)

#### Trademarks

Ethernet is a trademark of Xerox Corporation

NEBS is a trademark of Telcordia Technologies

UL is a registered trademark of Underwriters Laboratories

**GarrettCom, Magnum, Personal Switch, S-Ring, Link-Loss-Learn, Converter Switch and Convenient Switch** are trademarks and **Personal Hub** is a registered trademark of GarrettCom, Inc.

GarrettCom, Inc. reserves the right to change specifications, performance characteristics and/or model offerings without notice.

**Important:** The Magnum 6K32 Managed Switch contains no user serviceable parts. Attempted service by unauthorized personnel shall render all warranties null and void. If problems are experienced with Magnum 6K32 Switch products, consult Section 6, Troubleshooting, of this User Guide.

Copyright © 2005 GarrettCom, Inc. All rights reserved. No part of this publication may be reproduced without prior written permission from

GarrettCom, Inc.

Printed in the United States of America.

**Contacting GarrettCom, Inc**

Please use the mailing address, phone and fax numbers and email address listed below:

GarrettCom, Inc.

213 Hammond Ave.

Fremont, CA 94539

**Phone (510) 438-9071**

*Fax (510) 438-9072*

Website: <http://www.GarrettCom.com>

***email support@garrettcom.com***

**Federal Communications Commission****Radio Frequency Interference Statement**

*This equipment generates, uses and can radiate frequency energy and if not installed and used properly, that is in strict accordance with the manufacturer's instructions, may cause interference to radio communication. It has been tested and found to comply with the limits for a Class A computing device in accordance with the specifications in Subpart J of Part 15 of FCC rules, which are designed to provide reasonable protection against such interference when operated in a commercial environment. Operation of this equipment in a residential area is likely to cause interference, in which case the user at his own expense will be required to take whatever measures may be required to correct the interference.*

**Canadian Emission**

***This Class A digital apparatus meets all requirements of the Canadian Interference-Causing Equipment Regulations.***

*Cet appareil respecte toutes les exigences du Règlement sur le matériel du Canada. Cet appareil est Classe A.*

TABLE OF CONTENTS.....	Page
1.0 SPECIFICATIONS.....	1

1.1	Technical Specifications.....	1
1.2	Ordering Information .....	4
<b>2.0</b>	<b>INTRODUCTION.....</b>	<b>6</b>
2.1	Inspecting the Package and Product.....	6
2.2	Product Description - Magnum 6K32 Managed Switch .....	7
2.2.1	Magnum 6K32 and 6K32R chassis .....	8
2.2.2	Eight-port SFF fiber modules 100Mb fiber.....	9
2.2.3	Eight-Port Copper Module, 6K8-RJ45.....	10
2.2.4	Six-Port “4 + 2” Combo Modules, .....	10
2.2.5	Four-Port 10 Mb mm Fiber ST Modules.....	11
2.2.6	Gigabit (1000Mbps) port modules.....	<b>Error! Bookmark not defined.</b>
2.2.7	Packet Prioritization, 802.1p QOS .....	12
2.2.8	Frame Buffering and Flow Control .....	13
2.2.9	Managed Network Software (MNS-6K) for Magnum 6K32 .....	14
2.3	Features and Benefits .....	15
2.4	Applications .....	16
<b>3.0</b>	<b>INSTALLATION .....</b>	<b>20</b>
3.1	Locating Magnum 6K32 Switches .....	20
3.2	Connecting Ethernet Media.....	20
3.2.1	Connecting Fiber Optic <u>ST</u> -type, “twist-lock” .....	21
3.2.2	Connecting Fiber Optic <u>SC</u> -type, “Snap-In” .....	21
3.2.3	Connecting <u>Single-Mode</u> Fiber Optic .....	22
3.2.4	Connecting Twisted Pair .....	22
3.2.5	Connecting Twisted Pair .....	22
3.3	Table-Top or Shelf Mounting.....	23
3.3.1	Rack-mounting regular Magnum 6K32s.....	23
3.3.2	Rack-mounting, <u>Reverse</u> version of the Magnum 6K32s .....	24
3.4	Powering the Magnum 6K32 Managed Switch.....	25
3.4.1	Alarm Contacts for monitoring internal power .....	25
3.5	6K32 Port Module (6KPM) Installation.....	26
3.5.1	Preparation for Installing and Removing 6KPMs .....	26
3.5.2	Installing 6KPM Cards in the Magnum 6K32.....	29
3.5.3	Removing 6KPM Cards .....	31
3.6	Connecting the Console Terminal to Magnum 6K32.....	33
3.6.1	RS-232 (DB-9) Console Com port .....	33
<b>4.0</b>	<b>OPERATION.....</b>	<b>34</b>
4.1	Switching Functionality .....	34
4.2	Status LEDs.....	35
4.3	Up-link Cross-over Switch on RJ-45 port modules .....	35
4.4	Auto-cross (MDIX), Auto-negotiation, for RJ-45 ports .....	35
4.5	Flow-control, IEEE 802.3x standard.....	37
4.6	Power Budget Calculations for Magnum 6K32 PM’s.....	38
<b>5.0</b>	<b>MAGNUM 6K32 MANAGED SWITCH PORT MODULES.....</b>	<b>39</b>

5.1	Inspecting the Package and Product.....	39
5.2	6KPM Module Description .....	40
5.2.1	6KP6-RJMST “twist lock” Combo Module.....	40
5.2.1a	6KP6-RJ10ST, “twist lock” Combo Module .....	41
5.2.1b	6KP4-F10ST, “twist lock” Module.....	41
5.2.1c	6KP4-FLSTFX, “twist lock” Module.....	42
5.2.2	6KP6-RJMSC “snap-in” Fiber connector .....	42
5.2.3	6KP6-RJSSC “snap-in” connector .....	43
5.2.4	6KP6-RJSSCL <u>single-mode</u> “snap-in” connector .....	43
5.2.4a	6KP6-RJ10ST FL-ST-type, “twist-lock” connector.....	44
5.2.5	6KP8-MTRJ, <u>MTRJ Small-Form-factor</u> .....	45
5.2.5a	6KP6-MT10ST, Multi-mode ST-Fiber port .....	45
5.2.6	6KP8-45MT, <u>MTRJ Small-Form-Factor</u> .....	46
5.2.7	6KP8-MLC, <u>Small Form Factor</u> .....	46
5.2.8	6KP8-45LC, Combo <u>factor</u> and RJ-45 Connector .....	47
5.2.9	6KP8-RJ45 (Twisted Pair), 10/100Mb 8-Port.....	47
5.2.10	6KP8-45-2MT, multi-mode FX , <u>MTRJ Small-Form-Factor</u> .....	48
5.2.10a	6KP8-45-2LC, <u>LC Small-Form-Factor</u> .....	48
5.2.11	GBIC-SXSC Gigabit fiber(1000Mb), mm SC Connector.....	49
5.2.11a	GBIC-LXSC Gigabit fiber (1000Mb), mm SC Connector.....	50
5.2.12	6KM-BLNK .....	50
<b>6.0</b>	<b>TROUBLESHOOTING.....</b>	<b>50</b>
6.1	Before Calling for Assistance.....	51
6.2	When Calling for Assistance.....	51
6.3	Return Material Authorization (RMA) Procedure.....	52
6.4	Shipping and Packaging Information .....	53
	<b>APPENDIX A: WARRANTY INFORMATION .....</b>	<b>53</b>
	<b>APPENDIX B : INTERNAL DC POWER SUPPLY OPTIONS.....</b>	<b>53</b>
	<b>APPENDIX C: INTERNAL DC DUAL-SOURCE POWER OPTION .....</b>	<b>57</b>

### Revisions

**Rev A 05/05** : Minor updates, Auto-Cross(MDIX)

**Rev A 02/05** : Minor updates and tweak on LC connector diagram

**Rev A 08/04** : This revision is the initial release of the 6K32 manual.

## The Magnum Line

### ETHERNET CONNECTIVITY PRODUCTS

"DESIGNED AND MANUFACTURED IN THE USA"

#### OVERVIEW

GarrettCom, Inc. offers the premium-quality Magnum™ line of Ethernet LAN connectivity products with industry-standard functionality and built-in fiber configurability. Magnum products are designed for use in demanding Carrier Class, Industrial Grade and OEM applications where reliability is a primary consideration.

**6K Managed Switches**, Gigabit, 100 and 10 Mbps, fiber and copper ports, mix-and match. Features a family of modules for user configurability.

**Magnum MNS software**. Versions for 6K Switches and for mP62's.

**4K-Series Switches**, 100 and 10 Mbps, copper ports with optional fiber port, with auto-negotiating full switching performance.

**Quad-Series Fiber Switches**, 100 and 10Mbps, fiber and copper ports, mixed-speed and mixed-media types, full switching performance.

**"Outdoor" Ethernet Switches**, for temperature uncontrolled locations  
6 10/100 and 2 100Mb fiber ports, can be connected in strings and rings

**Mixed-Media Fiber Hub, 16-port Stackable**, 10/100 auto-sensing

**Dual Speed 8-port and 16-port Stackable**, 10/100 auto-sensing

**Stackable Hubs, SNMP Optional**

10Mb series and 100Mb series, both w/ optional port modules

**Personal Switches, 10/100Mb**

8 port dual speed, Auto-negotiable with fiber option

**Personal Hubs, 100Mb or 10/100Mb**

8-port, with two switched ports (1 fiber built in)

**Personal Hubs, 10Mb series**

8-port + AUI, stackable to 5 high, + optional BNC or fiber port

8 or 9-port and 4 or 5-Port Personal Hubs, w/ man. up-link sw.

**Converter Switches and Media Converters, 10Mb and 100Mb series**

All media combinations, incl. fiber ST, SC, mm., single mode

**The "X-line" of configurable MiXed Media products:**

**Stackable Concentrators, SNMP optional, 13-Ports**

**Repeaters, 2-Ports**

**Repeater Port Modules (RPMs)**, 6 types for Ethernet media

**Transceivers, 10Mb series Mini-Transceivers and Coax Models**

May, 05

**1.0 SPECIFICATIONS****1.1 Technical Specifications****Performance**

Filtering / Forwarding Rate:

Ethernet: 14,880 pps

Fast Ethernet: 148,800 pps

Gigabit Ethernet: 1,488,000 pps

Switching Processing Type: Store and Forward with IEEE 802.3x full-duplex flow -control, non-blocking

Data Rate: 10Mbps, 100Mbps and 1000Mbps

Address Table Capacity: 4K node, self-learning with address aging

Packet buffer size : 240KB for 10/100 and 120KB for 1000Mb

Latency: 5  $\mu$ s + packet time (100 to 100Mbps)

15  $\mu$ s + packet time (10 to 10 Mbps, and 10 to 100Mbps)

**Network Standards and Compliance**

Ethernet V1.0/V2.0 IEEE 802.3: 10BASE-T,

IEEE 802.3u: 100Base-TX, 100BASE-FX

IEEE 802.3z: 1000BASE-X Ethernet(Auto-negotiation)

IEEE 802.3ab: 1000BASE-X Ethernet

IEEE 802.1p: Priority protocol

IEEE 802.1d: Spanning tree protocol

IEEE 802.1w: Rapid Spanning tree protocol

IEEE 802.1q: VLAN Tagging

IEEE 802.3x: Flow Control

IEEE 802.3ad: Link Aggregation (Trunking)

**Maximum 10 Mbps Ethernet Segment Lengths**

Unshielded twisted pair - 100 m (328 ft)

Shielded twisted pair - 150 m (492 ft)

10BASE-FL multi-mode fiber optic - 2 km (6,562 ft)

10BASE-FL single-mode fiber optic - 10 km (32,810 ft)

**Maximum Standard Fast Ethernet Segment Lengths:**

10BASE-T (CAT 3, 4, 5 UTP) - 100 m (328 ft)

100BASE-TX (CAT 5 UTP) - 100 m (328 ft)

Shielded twisted pair - 150 m (492 ft)

100BASE-FX, half-duplex, multi-mode - 412 m (1350 ft)

100BASE-FX, full-duplex, multi-mode - 2.0 km (6,562 ft)

100BASE-FX, half-duplex, single-mode - 412 m (1350 ft)

100BASE-FX, full-duplex, single-mode - 20.0 km (66K32 ft)

100BASE-FX, full-duplex, Long Reach - 40.0 km (122K ft)

**Maximum Standard Gigabit Ethernet Segment Lengths:**

1000BASE-T (CAT5E or higher is recommended) - 100 m

1000BASE-SX, full-duplex, multi-mode(62.5 $\mu$ m cable) - 220m

1000BASE-SX, full-duplex, multi-mode(50 $\mu$ m cable) - 550m

1000BASE-LX, full-duplex, single-mode(62.5 $\mu$ m cable) -5Km

**Fiber connector types supported:**

ST-type (twist-lock)  
SC-type (snap-in)  
MTRJ-type Small Form Factor (SFF)  
LC-type Small Form Factor (SFF)  
GBIC modules

**LEDs: Per Port**

**LK:** Steady ON when media link is operational

**ACT:** ON with receiver port activity

**FDX/HDX:** ON = Full-Duplex Mode  
OFF = Half-Duplex Mode

**100/10:** ON = 100Mbps speed  
OFF = 10 Mbps

**Operating Environment**

Ambient Temperature: 25° to 130° F (-5° to 55°C)

Storage Temperature: -40° to 185°F (-40° to 85°C)

Ambient Relative Humidity: 5% to 95% (non-condensing)

Altitude: -200 to 13,000 ft. (-60 to 4000m)

Conformal Coating option: Request quote

**Packaging**

Enclosure: Rugged High strength metal. Suitable for stand-alone or rack-mounting

Dimensions: 1.70in. H x 17.0in. W x 9.0in. D  
4.32cm H x 43.2cm W x 22.9cm D

Cooling method: Fan cooled, @ 3@ 7 cfm ea.

**Management Console connector**

DB-9 for RS-232 “ null-modem “ cable (sometimes called an X-modem cable)

**Power Supply (Internal)**

AC Power Connector: IEC-type, male recessed at rear of chassis, with adjacent manual ON-OFF switch (optional if no Alarms Cont.)

Input Voltage: 100 to 240 VAC (auto-ranging)

Input Frequency: 47 to 63 Hz (auto-ranging)

Power Consumption: 45 watts max (with fiber module)

30 watts for a fully-loaded copper only model

**DC Power Supply (Options)**

**-48VDC Power** Input Voltage : -36 to -70 VDC

**24VDC Power** Input Voltage : 20 to 40VDC

**125VDC Power and 100VDC** Input Voltage : 88 to 150VDC

Std. Terminal Block : “ -, GND, + ”

Power Consumption: same as for AC models, see above

For (**Optional**) DC internal power supplies at -48VDC, 24VDC and 125VDC, including Dual Source options (for continuity of operation when either of the DC input sources are interrupted), see Appendices B and C.



**Alarm Contact (Optional)**

Alarm Contact option is offered as a special order. The alarms can be configured through two normally closed Form-C contacts, one for loss of power and one software alarm through user selectable software traps.

**Manual switches for modular slot port module only**

The copper daughter board has an internal switch for selecting MDI-MDIX crossover on port # 1, located next to the port internally.

Note: Other port-specific user settings ( such as FDX or HDX,AUTO OFF, copper 10/100 speed) can be configured using software commands.

**Agency Approvals**

UL listed (UL1950), cUL, CE, Emissions meet FCC Part 15 Class A  
NEBS L3 and ETSI Compliant for Carrier Central Offices  
IEEE P1613 Environmental Standard for Electric Power Substations.  
IEC61850 EMC and Operating Conditions Class C for Power Substations

**Warranty:** Three years, return to factory

Made in USA

For a Configuration Guide, see the GarrettCom web site at

[http://www.garrettcom.com/techsupport/insertion\\_guides/6k32cg.pdf](http://www.garrettcom.com/techsupport/insertion_guides/6k32cg.pdf)

Email [mktg@GarrettCom.com](mailto:mktg@GarrettCom.com) for additional details.

**1.2 Ordering Information****Magnum Managed Switch****MODEL      DESCRIPTION**

**Magnum 6K32** Magnum 6K32 Managed Switch(32 total ports max.) base unit provides 24 10/100 RJ-45 ports and one optional port module slot, which may be configured with a selection of 10/100/1000Mb fiber and copper connector types, 8 ports max., Wire speed filtering and forwarding across all ports, 802.3x flow control, 802.1p priority packet processing, self-learning 4K-node address table, large 240KB packet buffers for 10/100 and 120KB for 1000Mb. Plug-and-play switching services, front-mounted LEDs, internal auto-ranging AC power supply, 19" rack-mounting brackets. For licensed managed networks software, see MNS-6K datasheets.

**Magnum 6K32R:** "Reverse" model, same as Model 6K32 except the user ports and the power input connectors are in the rear. Two sets of LEDs (both rear and front) provide duplicate status data for viewing from either side.

**Magnum 6K32-48VDC:** Same as 6K32 except the power input is -48VDC

**Magnum 6K32R-48VDC:** Same as 6K32R except the power input is -48VDC

**Magnum 6K32-24VDC:** Same as 6K32 except the power input is 24VDC

**Magnum 6K32R-24VDC:** Same as 6K32R except the power input is 24VDC

**Magnum 6K32-125VDC:** Same as 6K32 except the power input is 125VDC

**Magnum 6K32R-125VDC:** Same as 6K32R except the power input is 125VDC

**Configuration Options:**

Each Magnum 6K32 and 6K32R base unit has one port module slot to be configured with one of the port modules listed below:

**Magnum 6K32 Port Modules**

<b>6KP8-RJ45</b>	TP Module, w/eight 10/100Mbps auto-negotiating RJ-45 ports
<b>6KP4-F10ST</b>	"2+2" 10Mb Fiber module, w/ four 10Mb 2km FL ST connectors
<b>6KP4-FXSC</b>	"2+2" 100Mb Fiber module, w/ four 100Mb 2km FX SC connectors
<b>6KP4-FXST</b>	"2+2" ST Fiber module, w/ s, four 100Mb 2km FX ST connectors
<b>6KP4-FLSTFX</b>	"2+2" ST Fiber module, w/ two 100Mb and two 10Mb ports, 2km
<b>6KP6-RJMST</b>	"4+2" module, w/four RJ-45 ports and two 2km mm FX SC's
<b>6KP6-RJMSC</b>	"4+2" module, w/four RJ-45 ports and two 2km mm FX ST's
<b>6KP6-RJSSC</b>	"4+2" module, w/four RJ-45 ports and two 20km Sgl.m FX SC's
<b>6KP6-RJSSCL</b>	"4+2" module, w/four RJ-45 ports and two 40km Sgl.m FX SC's
<b>6KP8-MTRJ</b>	SFF Fiber module, w/eight 100Mb mm FX MT-RJ connectors
<b>6KP8-MLC</b>	SFF Fiber module, w/eight 100Mbps mm FX LC connectors
<b>6KP8-SLC</b>	SFF Fiber module, w/eight 100Mbps sgl-m FX LC connectors
<b>6KP8-45MT</b>	"4+4" module, w/four RJ-45 ports and four 2km mm FX MT-RJ's
<b>6KP8-45LC</b>	"4+4" module, w/four RJ-45 ports and four 2km mm LC connectors
<b>6KP6-MT10ST</b>	"4+2" module, w/four MTRJ ports and two 10Mb 2km FL ST's
<b>6KP6-RJ10ST</b>	"4+2" module, w/four RJ-45 ports and two 10Mb 2km FL ST's

**6KP8-45-2MT** “6+2” module, w/six RJ-45 ports and two 2km mm MTRJ connectors  
**6KP8-45-2SLC** “6+2” module, w/six RJ-45 ports and two 100Mb 15km sgl. mode FX LC connectors

#### Gigabit Transceiver options

**6KP5V-G4RJ** “G+2” module, with one GBIC transceiver and four 10/100 RJ-45 connectors  
**6KP3V-G2SC** “G+2” module, with one GBIC transceiver and two 100Mb 2km FX SC fiber ports connectors  
**GBPM-2OTX** Two port Gigabit module provides two GBIC open transceiver ports for a user-selectable GBIC transceiver module  
**GBPM-COTX** One slot Gigabit 6K module provides one GBIC open transceiver port for a user-selectable GBIC transceiver module  
**GBIC-SXSC** GBIC transceiver module for use in GBPM-xOTX. One 1000BASE-SX port with multimode SC fiber connector  
**GBIC-LXSC10** GBIC transceiver module for use in GBPM-xOTX. One 1000BASE-LX/LH port with 1310nm single mode SC(10km) fiber connector  
**GBIC-LXSC25** GBIC transceiver module for use in GBPM-xOTX. One 1000BASE-LX/LH port with 1310nm single mode SC(25km) fiber connector  
**GBIC-LXSC40** GBIC transceiver module for use in GBPM-xOTX. One 1000BASE-ZX port with 1550nm, single mode SC(40km) fiber connector  
**GBIC-LXSC70** GBIC transceiver module for use in GBPM-xOTX. One 1000BASE-ZX port with 1550nm, single. mode SC(70km) fiber connector.  
**GBIC-TP** GBIC transceiver module for use in GBPM-xOTX. One 802.3ab 1000BASE-T port with RJ-45 connector

**6KM-BLNK** Blank cover for one 6K32 module slot opening in a Magnum 6K32 or 6K32R chassis

**CONSOLE CBL** Industry standard serial cable, DB-9 connectors for RS-232 “ null-modem “ connection (sometimes called an Xmodem cable), used to connect a PC or a character terminal to the Management port.

**CONSOLE USB** Console attachment cable, serial to USB, cable with one DB9 for the managed Switch and a USB interface for the USB connector to a PC.

See also the “Configuration Guide” for the 6K32 on the GarrettCom web site at [http://www.garrettcom.com/techsupport/insertion\\_guides/6k32cg.pdf](http://www.garrettcom.com/techsupport/insertion_guides/6k32cg.pdf).

GarrettCom, Inc. reserves the right to change specifications, performance characteristics and/or model offerings without notice.

## **2.0 Introduction**

### **2.1 Inspecting the Package and Product**

Examine the shipping container for obvious damage prior to installing this product; notify the carrier of any damage that you believe occurred during shipment or delivery. Inspect the contents of this package for any signs of damage and ensure that the items listed below are included.

This package should contain:

- 1 Magnum 6K32 Managed Switch, base unit  
(configured with user-selected port module option in modular slot)
- 1 AC Power Cord (U.S. and other 115 VAC only)
- 1 Set of metal “Ears” for 19” rack mounting
- 1 Installation and User Guide (this manual)
- 1 Product Registration Card

Remove the items from the shipping container. Be sure to keep the shipping container should you need to re-ship the unit at a later date. To validate the product warranty, please complete and return the enclosed Product Registration Card to GarrettCom, Inc. as soon as possible.

In the event there are items missing or damaged, contact the party from whom you purchased the product. If the unit needs to be returned, please use the original shipping container if possible. Refer to Section 6, Troubleshooting, for specific return procedures.

## 2.2 Product Description - Magnum 6K32 Managed Switch

The Magnum 6K32 Managed Switch provides high port density, with up to 32 ports in a 1U rack-mount package. It is used to boost the performance of large Ethernet LANs, typically serving as a “backbone” switch in *carrier-class (Telco)* or *Industrial* applications. Being a member of Magnum 6K-family, the Magnum 6K32 has modularity via a selection of 20 different modules where any one may be configured in the A slot, and proven reliability for heavy duty applications. It has 24 ports of 10/100 RJ-45 ports, plus a mix of fiber and copper ports, 10 Mb or 100Mb or Gigabit, in the modular slot.

The Magnum 6K32 is equipped with MNS-6K Managed Network Software to handle industry-standard IEEE 802.1p QOS prioritization and non-blocking wire speed on all ports. It provides high performance switching services for both “smooth” streaming and “bursty” data traffic. For redundant LANs, it offers S-ring, Link-Loss-Learn, STP and RSTP. Security features include SNMPv3, SSL/SSH, 802.1X, Port Security, and Tagged VLANs. See MNS-6K materials for further details about software.

The Magnum 6K32’s port flexibility is achieved via a family of 6K port modules for copper and fiber-built-in (emphasizing Small Form Factor fiber for high fiber port density), 6-port modules for fiber and RJ-45 combinations, and 1Gb or 2Gb port module selections using GBICs. These modules can be factory configured in a base chassis unit (or may be changed in the field by trained technicians) to adapt the unit to the user’s application and Ethernet cabling requirements. Even evolving mixed-media requirements for 10Mb and 100Mb fiber and copper as well as Gigabit ports can be handled by the Magnum 6K32 product.

The packaging and power-input options target the Magnum 6K32 at heavy-duty applications. The chassis mounting rack style may be “regular” (with the ports and LEDs in the front and the power input and management console connector in the rear) or “Reverse” (with the ports and LEDs and the power-input and the management console connector all in the rear and a duplicate set of LEDs in the front). Rack widths accommodated include standard 19” RETMA, ETSI, and 23” Telco. Input power may be AC, or –48VDC for Telco environments, or 24VDC for Industrial applications.

Designed for use in network traffic centers, the Magnum 6K32 provides high performance plug-and-play hardware operation, 802.1p packet prioritization in hardware, and industry-standard managed networks software functionality, all in convenient 1U rack-mount packages.

### 2.2.1 Magnum 6K32 and 6K32R chassis

The Magnum 6K32 is a 19" rack-mountable Ethernet Switch with fixed 24 10/100 RJ-45 ports and a modular slot (8 ports max.) for configuration flexibility. The modular slot, shown on the right side below, may be configured with any of a large selection of fiber and copper port types and combinations of types, typically eight ports module max., but sometimes six (4+2) or four(2+2) or (4+4) ports or even one (G+4) or (G+2) or two Gb (GBPMV-2OTX) port module. The modular slot may be configured with a Gb module that accepts GBICs. The port types configurable using the modular slots allows the 6K32 to efficiently serve a large variety of applications, even those using some fiber media. The Magnum 6K32 port modules are normally factory installed, but may be changed or added in the field. (See Section 5) Status LEDs are part of each port module and are viewable when connecting the Ethernet media. A "regular" rack-



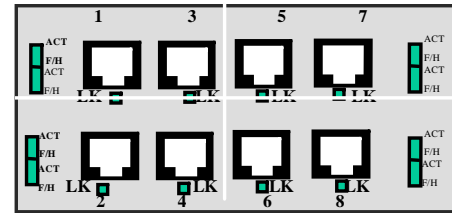
**Figure 2.2.1a: 6K32 front view, configured for 24 RJ-45 ports + 1 Modular slot with 6KP6-RJM5C**

mount 6K32 is shown in Figure 2.2.1a. On "Reverse" rack-mount models, all the ports and power supply are on the rear part of the box, whereas the 2<sup>nd</sup> set of the dual LEDs (front and back) for port status are in the front. Of course, with the web based management option or by the use of SNMPc 3<sup>rd</sup> party software, the port status data can also be seen through GUI software on remote computers and terminals.

Designed for use in Carrier Class and Industrial networks with some segments requiring Gigabit backbone interconnections among network centers, the managed Magnum 6K32 is easy to deploy, manage and maintain. Addresses of attached nodes are automatically learned and maintained, adapting the switching services to network changes and expansions to provide plug-n-play operation.

The modules that may be configured and used in Slot A are described here.

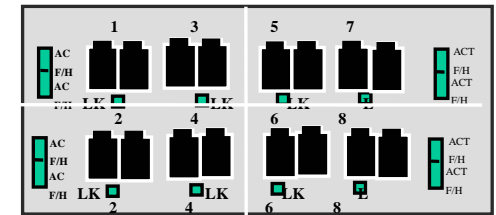
### 2.2.2 Eight-port SFF fiber modules (6K8-MTRJ, 6K8-MLC), 100Mb fiber



**Fig.2.2.2 :**  
**SFF Fiber Port Modules,**  
**6K8-MTRJ (to the left)**  
**and**  
**6K8-MLC or -SLC**  
**(below)**

In an eight-port SFF fiber port module, all of the fiber ports are of the same speed (100Mb), mode, and connector type. Models are available with Small Form Factor (SFF) are multi-mode MT-RJ or LC-type connectors, and single-mode LC-type connectors.

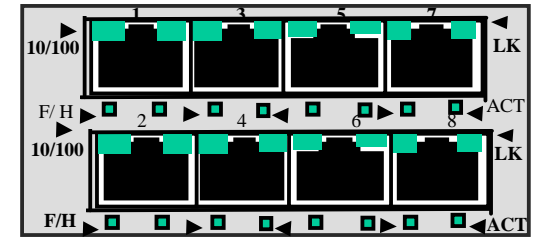
The 100Mb fiber eight-port modules for the Magnum 6K32's normally are set (factory default) to operate in full-duplex mode for best fiber distance and performance. Using the 6K32's MNS software, the user may select full- or half-duplex mode per-port through set-up of the software (See Magnum 6K32 MNS Software Manual) for the flexibility to adapt to any FDX or HDX type of Fast Ethernet devices).



There are three LED's per fiber port. The Link (LK) LED indicates "ready for operation" on that port when lit, the F/H LED indicates operation in full-duplex mode when ON (half-duplex when OFF), and the blinking ACT LED indicates receiving Activity on the port. A fiber cable must be connected into a SFF port and the Link (LK) indicator for that port must be ON (indicating there is a powered-up device at the other end of the cable) in order for a LK LED to provide valid indications of operating conditions on that port.

### 2.2.3 Eight-Port Copper Module, 6K8-RJ45

The 6K32's 8-port Copper port module, model 6K8-RJ45, provides eight 10/100Mb switched RJ-45 ports. The 10/100Mb switched ports



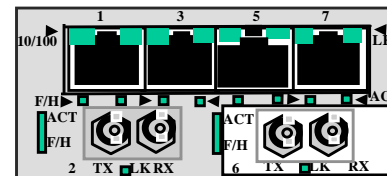
normally (as a default setting) are independently N-way auto-negotiating for operation at 10 or 100Mb speed in full- or half-duplex mode, i.e., each independently selects a mode and speed to match the device at the other end of the twisted pair cable. (See Section 4.3 for auto-negotiation details)

On the model 6K8-RJ45 module, there are four LEDs for each port, two in the connector and two separate. The LK (Link) LED indicates “ready for operation” on that port when lit. The blinking ACT (Activity) LED indicates receiving Activity on that port when lit. The 10/100 LED indicates operation at 100Mb speed when ON and at 10 Mb speed when OFF (when auto-negotiation is not disabled). The FDX/HDX LED is ON to indicate full-duplex operation and OFF to indicate half-duplex mode. A twisted pair cable must be connected into an RJ-45 port and the Link (LK) indicator for that port must be ON (indicating there is a powered-up device at the other end of the cable) in order for a LK LED to provide valid indications of operating conditions on that port.

Using the MNS-6K software, the user may disable auto-negotiation and fix the desired operation of each RJ-45 port. MNS-6K Software allow to select 10Mb or 100Mb speed and full- or half-duplex mode per-port as per user requirement. (See Magnum MNS-6K Software Manual for details info). See Section 4.3 for Up-Link switch.

### 2.2.4 Six-Port “4 + 2” Combo Modules, 4@ 10/100 RJ-45 and 2@ 100Mb fiber

The combo six-port modules are combinations of copper and fiber media, available as four 10/100 switched RJ-45 copper ports and two 100Mb switched multi-



4@ RJ-45 + 2@ 100Mb SC



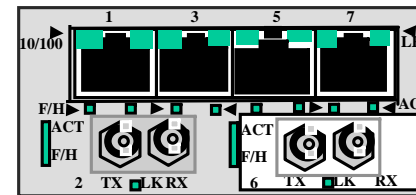
4@ RJ-45 + 2@ 100Mb ST



mode fiber ST, SC or single mode SC or Long Reach SC ports. For ports numbering, ports 1,3,5,7 are copper, ports 2 and 6 are fiber, ports 4 and 8 are not present.

The four RJ-45 ports operate just like the 8-port copper module, and the two fiber ports operate at 100Mbps full-duplex (default). User mode control per port through the MNS software is also the same. See Section 4.3 for Up-Link switch on port 1.

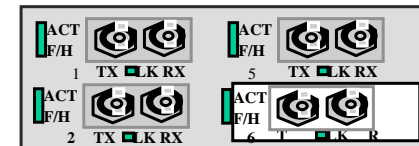
On Magnum “4+2” Combo modules, there are four LED’s for each RJ-45 port, which indicate status the same as described for the 6K8-RJ45 in Section 2.2.3 above. The fiber port’s LEDs indicate status the same way as described for the SFF fiber modules in Section 2.2.2 above. Color-coding on the panel of the module shows which LEDs belong to which port.



The Magnum Combo six-port modules are also available with 4@ MTRJ 100Mb mm SFF fiber and 2@10Mb fiber mm ST ports, and with 4@ RJ45 10/100 copper and 2@10Mb fiber mm ST

ports. The 4@ RJ-45 + 2@ 10 Mb ST operation of the SFF fiber and the RJ-45 half of the module is as described for those port types above. For detailed information about 10Mb mm ST fiber half of the module, please check section 2.2.5.

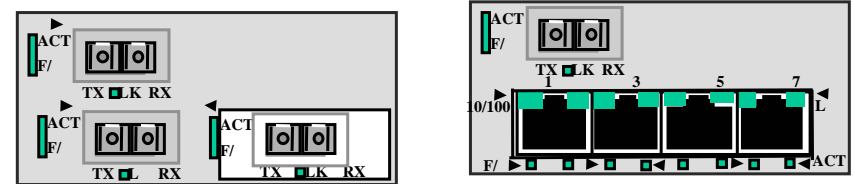
### 2.2.5 Four-Port 10 Mb mm Fiber ST Modules



The 4port @10Mb ST fiber modules behave the same as the 8@100Mb ST fiber modules except for the 10Mb speed. For ports numbering, ports 1, 2, 5, 6 are present, ports 3, 4, 7, 8 are not present. The default setup on the 10Mb fiber module is half-duplex, which allows the Magnum 6K32 Switch to connect to any 10Mb hub or media converter or almost any other device with a 10Mb fiber Ethernet port. User mode control per port through the MNS software is the same as the other 6K32 modules. The fiber ports support fiber cabling distances according to the 10BASE-FL standard, i.e., 2km distance for multi-mode fiber. (Single-mode for up to 10Km distance may be available as a special order configuration).

### 2.2.6 Gigabit (1000Mbps) port modules

The Magnum 6K32 offered a wide option Gigabit speed with multiple choice for the modular slot. While up to two Gigabit modules (maxm.) can be configured in the modular slot. The Gigabit port option for the modular slot comes in couple of different configuration. The two Giga port has been offered as GBPM-2OTX (fiber or RJ-45), whereas the single Gigabit module comes in flavor of G+4(10/100 RJ-45 ports) or G+2 (100Mb fiber ports) as shown below in the figure.



1 @ 1000Mb Fiber SC + 2 @ 100Mb SC

1 @ 1000Mb Fiber SC + 4 @ 10/ 100Mb

The 6K32 modules provide a GBIC opening for insertion of industry-standard GBICs to provide Gigabit (Gb) media flexibility. GBIC models are available for both multi-mode (550m) and single-mode (10, 25, 40, 70)km fiber options, and for Gigabit copper as well, with new models appearing often.

The 1000Mb Gigabit fiber-port modules on the Magnum 6K32 are normally set (factory default) to operate at AUTO mode for best fiber distance and performance. The 1000Mbps SC fiber-optic module on the Gigabit -SX and Gigabit-LX transceivers are compatible with the IEEE 802.3z Gigabit standards.

There are two LEDs mounted on each Gigabit port module. The Gigabit fiber port is by default configured at AUTO mode, and can be fix at 1000Mbps speed full-duplex mode at any times and has LEDs that indicate LK (Link status) and ACT (receiving activity) on that port when lit.

### 2.2.7 Packet Prioritization, 802.1p QOS

Quality of Service means providing consistent predictable data delivery to users from datagram paths that go all across a network. As a LAN device, the Magnum 6K32 can do its part to prevent any QOS degradation while it is handling Ethernet traffic through its ports and buffers.

The Magnum 6K32 switching hardware supports the IEEE 802.1p standard and

fulfills its role in support of QOS, giving packet processing priority to priority tagged packets according to the 802.1p standard. In addition to hardware support for QOS, the MNS software (R2) supports two priority queues that can be shared across the eight levels of defined packet priorities for application-specific priority control by the user through software configuration settings.

### 2.2.8 Frame Buffering and Flow Control

Magnum 6K32's are store-and-forward switches. Each frame (or packet) is loaded into the Switch's memory and inspected before forwarding can occur. This technique ensures that all forwarded frames are of a valid length and have the correct CRC, i.e., are good packets. This eliminates the propagation of bad packets, enabling all of the available bandwidth to be used for valid information.

While other switching technologies (such as "cut-through" or "express") impose minimal frame latency, they will also permit bad frames to propagate out to the Ethernet segments connected. The "cut-through" technique permits collision fragment frames (which are a result of late collisions) to be forwarded which add to the network traffic. Since there is no way to filter frames with a bad CRC (the entire frame must be present in order for CRC to be calculated), the result of indiscriminate cut-through forwarding is greater traffic congestion, especially at peak activity. Since collisions and bad packets are more likely when traffic is heavy, the result of store-and-forward operation is that more bandwidth is available for good packets when the traffic load is greatest.

When the Magnum 6K32 Switch detects that its free buffer queue space is low, the Switch sends industry standard (full-duplex only) PAUSE packets out to the devices sending packets to cause "flow control". This tells the sending devices to temporarily stop sending traffic, which allows a traffic catch-up to occur without dropping packets. Then, normal packet buffering and processing resumes.

Another feature implemented in Magnum 6K32 Switches is a collision-based flow-control mechanism (when operating half-duplex only). When the Switch detects that its free buffer queue space is low, the Switch prevents more frames from entering by forcing a collision signal on all receiving half-duplex ports to stop incoming traffic.

### **2.2.9 Managed Network Software (MNS-6K) for Magnum 6K32**

Magnum 6K32 Managed Switches are factory-loaded with licensed MNS-6K software. For additional information about MNS-6K, see the Magnum MNS-6K Software User guide in pdf format, a separate document normally accessed via the web-browser, <ftp://ftp.garrettcom.com/> or FTP client program by <ftp.GarrettCom.com> using

user : m6kuser

password : m6kuser

All the MNS-6K Software related information, *NEW* releases related to MNS Software can be accessed and download from Garrettcom's FTP site.

Or visit [www.GarrettCom.com/techsupport/index.htm#software](http://www.GarrettCom.com/techsupport/index.htm#software),

or email: [support@GarrettCom.com](mailto:support@GarrettCom.com) for further information.

## 2.3 Features and Benefits

### ■ Managed switching for high performance Ethernet LANs

Magnum 6K32 Switches provide non-blocking (all ports can run at full speed at once) performance with standard Managed Networks Software (MNS-6K) included. They are typically used in LAN traffic centers with 24 10/100Mb ports or one or 2 Gigabit ports for backbone connections, where managed network services are desired.

### ■ Switching services includes 802.1p QoS packet prioritization

The Magnum 6K32 switching hardware supports QoS, giving packet processing priority to priority tagged packets according to the IEEE 802.1p standard. For port- and application-specific priorities, the QoS software may be configured by the user.

### ■ Features Fiber-Built-In

Magnum 6K32 Managed Switches are designed at modular slot to naturally include fiber ports, and support mixes of multi-mode and single-mode; 10 Mb, 100Mb and 1000Mb speed; full-and half-duplex; classic Small Form Factor (SFF) and GBIC fiber connectors. RJ-45 10/100 ports can also be configured in the mix of port types.

### ■ Modular design for port flexibility, in a 1U space-saving rack-mount package

The 1U Magnum 6K32 chassis has 1 slot for port configurations. A family of 2, 4, 6 or 8 port modules allows the user to select the desired mix of port types and speeds. There are over 20 different modules in the family to choose from. The port modules are normally factory installed and tested, but may be changed in the field.

### ■ Rack-mounting may be standard or “reverse”, 19 inch or ETSI or 23” Telco

The standard rack mounting provides Ethernet ports and status LEDs in front, service connections (power input and management console) in the rear. “Reverse” rack mounting provides status LEDs in front and all cabling connections in the rear. Standard 19’ rack mount brackets are included, with ETSI and 23” Telco optional.

### ■ Standard AC power input, -48VDC or 24VDC or 125VDC input is optional

Standard AC power input is IEC plug, auto-ranging for worldwide use. For special applications, models with -48VDC or 24VDC or 125VDC are available. Dual Source DC input can also be selected and configured on the DC power input models.

### ■ Heavy-duty design for Telco (NEBS tested) and other industrial environments

Fiber ports take more power than copper ports, but the Magnum 6K32 design provides for this with heavy-duty components. The ambient temperature can be up to 55°C.

### ■ MNS-6K licensed Network Management Software included, S-Ring optional

Release 3.0 (summer '04) includes SNMP, Secure Web Management, RMON, CLI, Port Security; Port Mirroring; Port Settings Control; Telnet, TFTP, FTP support, Spanning Tree Protocol, RSTP, LLL, S-Ring Redundancy Mgr, (optional) multi-level QoS, Port- and Tag-based VLANs, GVRP, IGMP Snooping, SNMPc GUI support; Event Log; SNTP client for time-of-day; BootP and DHCP client for IP configuring, and password security. Supplied and updated via Internet and GCI FTP Server.

See MNS-6K product information and user manuals for software details.

## 2.4 Applications

Magnum 6K32 Fiber Switches offer high performance and a modular slot options to fulfill the choice of copper/Fiber, 10 or 100 or 1000Mb requirements. They offer the flexibility of 100Mbps fiber and copper ports as well as Gigabit ports in the modular slot, along with MNS-6K management software. Magnum 6K32 Switches are used in a variety of applications including Carrier-class (Telco), client/server computing, secure VLAN- performance upgrades to departmental networks, and LAN traffic centers that require Gb backbone services. The performance characteristic of the 6K32 Switches enables them to inter-connect a series of subnets (one subnet per 6K32 Switch port) in a LAN traffic center. The subnet connections may be via fiber or twisted pair cabling, 100Mbps or 10 Mbps speed, and full-or half-duplex mode.

The mixed-media capability in modular slot is ideal for upgrading existing Ethernet LAN networks where existing cabling must be accommodated. The fiber-built-in media capability provides future-proof fiber cabling for the LAN structure.

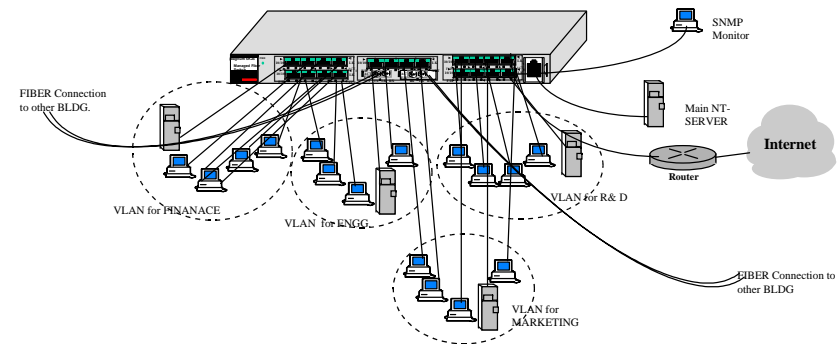
### Example 1 : Magnum 6K32 Switch for a VLAN application

Equipped with lots of advanced management features, the Magnum 6K32 Managed switch is able to handle a VLAN application and provide security and performance in an Ethernet network center. A secure VLAN-enabled network is simply an administratively-configured broadcast domain. The network administrator determines which ports and nodes are in which broadcast domains by setting membership profiles for each of them. The Magnum 6K32's VLAN capability can be configured in two types of virtual LANs; Port-based VLANs and Tag-based VLANs.

In an office environment where departments such as Finance, Engineering, R&D, and Marketing need to keep a secure LAN, the 6K32's VLAN feature will prevent traffic cross-over among traffic domains, and thus keep sensitive data and information controlled. The Managed Magnum 6K32 equipped with VLANs capability is ideal for any application where a secure VLAN to multiple departments is needed.

The modularity of the 6K32 Managed Switch makes it an attractive choice for use in applications with LAN connections to an organization's multiple site offices. The different offices can be easily connected together with the Fiber ports supported by the Magnum 6K32 Switch. A main NT-server in a secure area protected from earthquake or fire hazards can be connected to one or two full duplex Gigabit Fiber ports.

Full-duplex future proof fiber media can easily connect long distance subnets and provide a stable secure network to all applications. The SNMP management capability of the Magnum 6K32 Switch helps create a database of all the network subnets to easily manage the network. Secure web-based management is also included, with authentication and encryption to keep out even determined trouble-makers.

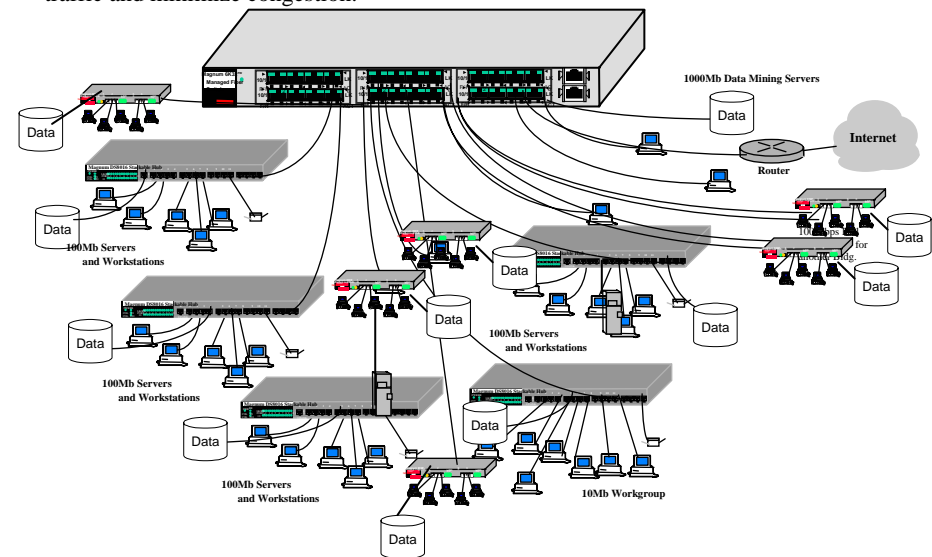


**Example 2.** In another Telecommunications storage data application, a secure managed switch is required to provide an Ethernet backbone for a diversified network with multiple subnets. The back bone consists of high speed LAN segments supported by 1000Mbps full-duplex future-proof fiber media to provide secure long distance LAN connections. The entire network is sharing a higher bandwidth Gigabit-enabled data-mining server for the vital database located in a separate secured building. The copper ports are required for multiple subnets inside the building. The entire spread network is managed to provide easy, detectable, uninterrupted support through a viewable SNMP monitor.

The Magnum 6K32 Managed Switch equipped with copper and optional dual Gigabit fiber ports on modular slot provides an economical and seamless solution to the requirements. The user-configurable Magnum 6K32 provides an extra boost to the network requirements by providing copper/fiber media along with the higher bandwidth support of 10/100 and 1000Mb. The user can utilize the SNMP feature equipped with VLAN, Port security, 802.1X, and other security features to provide a secure and stable network as per the requirement.

The 6K32 Managed Switch with NEBS Level 3 compliant and management flexibility allows the users more than one configuration alternative. The user has an

advantage by fulfilling the present requirements as well as benefiting from the multiple choices of modules to support future expansion as the network evolves. The dual Gigabit port option in modular slot boosts the bandwidth for high speed to support the peak traffic and minimize congestion.



### Example 3 Redundant Application

In a redundant application for high network availability where a rack-mountable managed switch with over 24 ports is required with dense port features, Magnum 6K32's equipped with redundant LAN features like S-Ring, RSTP, Link-Loss-Learn and various security features are easily qualified for the application. The -48VDC input power option with Dual Source is a useful option in telecom central offices.

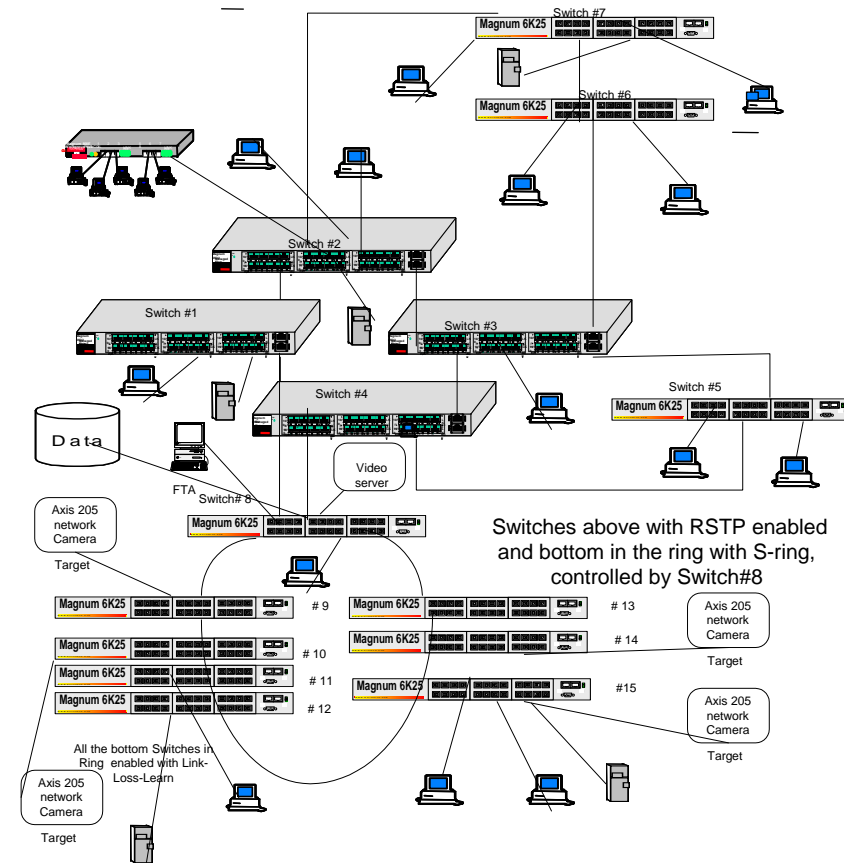
The Magnum 6K32 with two Gigabit ports in the modular slot allows it to connect into a Gb mesh structure with RSTP and S-Ring combo used in a no-single-point-of-failure self-healing LAN topology along with a ring of multiple 6K25s at the edge to efficiently recover from a fault in the network. The industry standard Rapid Spanning Tree Protocol 802.1d is used in top eight switches (see diagram below) to perform GB mesh fault recovery, whereas the bottom ring setup has been configured with S-Ring and Link-Loss-Learn for faster recovery in a big ring.

A redundant LAN setup not only provides a reliable recovery solution



from network faults, but also improves operating up-time to simplify maintenance and save money and valuable time. In a critical application where secure data has been stored in a data mining storage facility, a redundant network provide a more secure solution.

The figure below has Magnum 6K32's and 6K25's connected over the gigabit mesh structure for a high bandwidth secure redundant LAN setup.



**Fig: A redundant network with RSTP and S-Ring using Magnum 6K32's**

### 3.0 Installation

Before installing the equipment, it is necessary to take the following precautions:

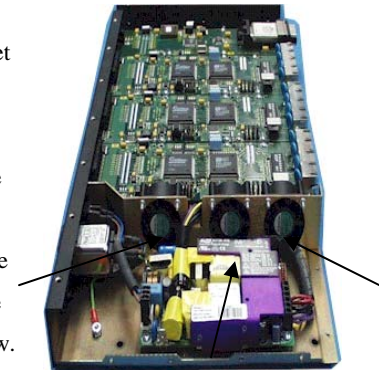
- 1.) If the equipment is mounted in an enclosed or multiple rack assembly, the environmental temperature around the equipment must be less than or equal to 50°C.
- 2.) If the equipment is mounted in an enclosed or multiple rack assembly, adequate air flow must be maintained for proper and safe operation.
- 3.) If the equipment is mounted in an enclosed or multiple rack system, placement of the equipment must not overload or load unevenly the rack system.
- 4.) If the equipment is mounted in an enclosed or multiple rack assembly, verify the equipment's power requirements to prevent overloading of the building's electrical circuits.
- 5.) If the equipment is mounted in an enclosed or multiple rack assembly verify that the equipment has a reliable and uncompromised earthing path.

This section describes installation of the Magnum 6K32 Switches, as well as connection of the various Ethernet media types.

### 3.1 Locating Magnum 6K32 Switches

The location of a Magnum 6K32 Switch is dependent on the physical layout of the network. Typically the Switch is placed in a central wiring location where groups of network devices need to be connected in order to communicate with each other. These Switches are typically rack mounted in a wiring closet (see Section 3.3.2 below), but because they have rubber feet they can also be installed on a shelf or table top unit. The compact size allows it to be easily placed in an office or lab area, and it can also be either shelf or wall-mounted (see Section 3.3.1 below).

Locate an AC receptacle that is within six feet (2 meters) of the intended Magnum 6K32 site. The rugged metal case of the Magnum 6K32 will normally protect it from accidental damage in a lab or workplace setting. Maintain an open view of the front to visually monitor the status LEDs. Keep an open area around the unit so that cooling can occur from the small fan on the left side, while the unit is in operation. See figure below.



**Figure 3.1: Location of the Magnum 6K32's cooling fans**

### 3.2 Connecting Ethernet Media

The Magnum 6K32 Switches are specifically designed to support all standard Ethernet media types within a single Switch unit. This is accomplished by using a family of different port Modules which can be

individually selected and configured per-port. See Section 2.4 for a description of the PMs.

The various media types supported along with the corresponding IEEE 802.3 and 802.3u standards and connector types are as follows:

<u>IEEE Standard</u>	<u>Media Type</u>	<u>Max. Distance</u>	<u>Port Module</u>
<b><u>Fiber:</u></b>			
1000BASE-FX	mm <sup>1</sup> Fiber	220m ( ft)	GBIC-SXSC
	sgl.m <sup>2</sup> Fiber	70km	GBIC-LXSC
100BASE-FX	mm <sup>1</sup> Fiber	2.0km (6,562 ft)	6K6-MS, -MST
	sgl.m <sup>2</sup> Fiber	18.0km (95K ft)	SSC, SSCL
small form factor	mm <sup>1</sup> Fiber	2.0km (6,562 ft)	6K8-MTRJ, -MLC
small form factor	sgl.m <sup>1</sup> Fiber	15 km	6KP8- SLC
<b><u>Copper:</u></b>			
10BASE-T and 100BASE-TX	twisted pair	100m (328 ft)	6K8-RJ45
	<sup>1</sup> mm = multi-mode	<sup>2</sup> sgl.m = single-mode	

### 3.2.1 Connecting Fiber Optic ST-type, "twist-lock"

The following procedure applies to installations using a PM with ST-type fiber connectors. This procedure applies to ports using a 6K32 module, MST-type port.

1. Before connecting the fiber optic cable, remove the protective dust caps from the tips of the connectors on the PM. Save these dust caps for future use.
2. Wipe clean the ends of the dual connectors with a soft cloth or lint-free lens tissue dampened in alcohol. Make certain the connectors are clean before connecting.
 

**Note:** One strand of the duplex fiber optic cable is coded using color bands at regular intervals; you must use the color-coded strand on the associated ports at each end of the fiber optic segment.
3. Connect the Transmit (TX) port (light colored post) on the Magnum PM to the Receive (RX) port of the remote device. Begin with the color-coded strand of the cable for this first TX-to-RX connection.
4. Connect the Receive (RX) port (dark colored post on the PM) to the Transmit (TX) port of the remote device. Use the non-color coded fiber strand for this.
5. The LINK LED on the front of the PM will illuminate when a proper connection has been established at both ends (and when power is ON in the unit). If LINK is not lit after cable connection, the normal cause is improper cable polarity. Swap the fiber cables at the PM connector to remedy this situation.

### 3.2.2 Connecting Fiber Optic SC-type, "Snap-In"

The following procedure applies to installations using a PM with SC-type fiber connectors, i.e., using 6K-MS, 6K-SSC single-mode.

When connecting fiber media to SC connectors, simply snap on the two square male connectors into the SC female jacks of the 6KPM until it clicks and secures.

### 3.2.3 Connecting Single-Mode Fiber Optic

When using single-mode fiber cable, be sure to use single-mode fiber port connectors. Single-mode fiber cable has a smaller diameter than multi-mode fiber cable (9/125 microns for single-mode, 50/125 or 62.5/125 microns for multi-mode where xx/xx are the diameters of the core and the core plus the cladding respectively). Single-mode fiber allows full bandwidth at longer distances, and may be used to connect 10 Mb nodes up to 10 Km apart, or 18Km with the 6K-SSC.

The same procedures as for multi-mode fiber applies to single-mode fiber connectors. Follow the steps listed in Section 3.2.2 above.

### 3.2.4 Connecting Twisted Pair (RJ-45, CAT3, CAT5, Unshielded or Shielded)

The RJ-45 ports of the Magnum 6K32 can be connected to the following two media types: 100BASE-TX and 10BASE-T. CAT 5 cables should be used when making 100BASE-TX connections. When the ports are used as 10BASE-T ports, CAT 3 may be used. In either case, the maximum distance for unshielded twisted pair cabling is 100 meters (328 ft).

<u>Media</u>	<u>IEEE Standard</u>	<u>Connector</u>
Twisted Pair (CAT 3, 4, 5)	10BASE-T	RJ-45
Twisted Pair (CAT 5)	100BASE-TX	RJ-45

**NOTE :** *It is recommended that high quality CAT. 5 cables (which work for both 10 Mb and 100Mb) be used whenever possible in order to provide flexibility in a mixed-speed network, since dual-speed ports are auto-sensing for either 10 and 100Mb/s.*

The following procedure describes how to connect a 10BASE-T or 100BASE-TX twisted pair segment to the RJ-45 port. The procedure is the same for both unshielded and shielded twisted pair cables.

1. Using standard twisted pair media, insert either end of the cable with an RJ-45 plug into the RJ-45 connector of the port. Note that, even though the connector is shielded, either unshielded or shielded cables and wiring may be used.
2. Connect the other end of the cable to the corresponding device
3. Use the LINK LED to ensure proper connectivity by noting that the LED will be illuminated when the unit is powered and proper connection is established

### 3.2.5 Connecting Twisted Pair (CAT5E or better, Unshielded or Shielded)

The RJ-45 Gigabit ports of the Magnum 6K32 can be connected to the media types, 1000BASE-T or CAT 5E or better 100-ohm UTP or shielded twisted pair (STP) balanced cable. The CAT 5E or better 100-ohm UTP or shielded twisted pair (STP) balanced cable is recommended to use when making 1000BASE-TX connections. In either case, the maximum distance for unshielded twisted pair cabling is 100 meters (328 ft). See Section 4.3 for manual Up-Link switch on port 1 of copper port modules.

<u>Media</u>	<u>IEEE Standard</u>	<u>Connector</u>
Twisted Pair (CAT 5E)	1000BASE-T	RJ-45

**NOTE :** *It is recommended that high quality CAT. 5E cables (which work for both 100 Mb and 1000Mb) be used whenever possible in order to provide flexibility in a mixed-speed network.*

The following procedure describes how to connect a 1000BASE-T twisted pair segment to the RJ-45 port. The procedure is the same for both unshielded and shielded twisted pair cables.

1. 1000Base-T connections require that all four pairs or wires be connected. Insert either end of the cable with an RJ-45 plug into the RJ-45 connector of the port. Note that, even though the connector is shielded, either unshielded or shielded cables and wiring may be used.
2. Connect the other end of the cable to the corresponding device
3. Use the LINK LED to ensure proper connectivity by noting that the LED will be illuminated when the unit is powered and proper connection is established

### 3.3 Table-Top or Shelf Mounting

The Magnum 6K32 Manageable Switches can be easily mounted on a table-top or any suitable horizontal surface, and has four rubber feet to provide stability without scratching finished surfaces.

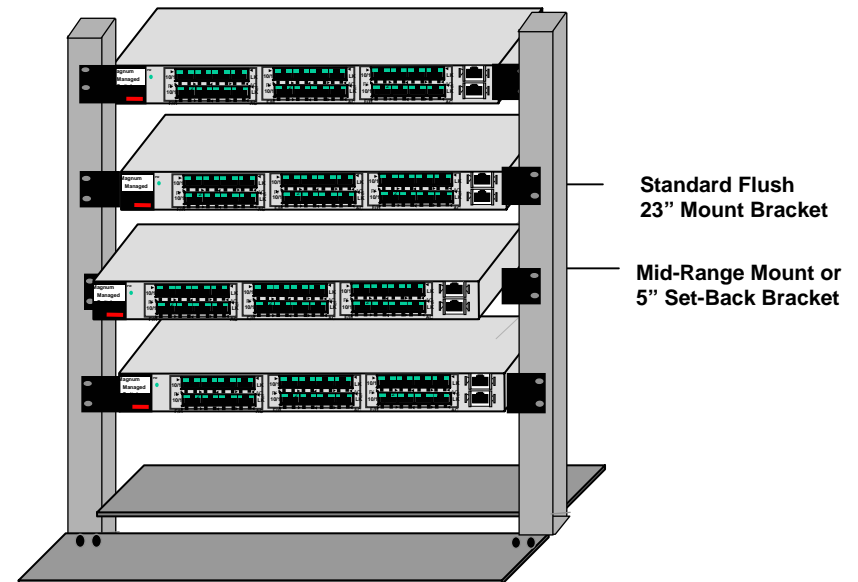
#### 3.3.1 Rack-mounting (for 19" RETMA racks), regular Magnum 6K32s

Installation of a Magnum 6K32 Fiber Switch in a 19" rack is a simple procedure. The units are 1U (1.70") high. When properly installed, the front-mounted LED status indicators should be in plain view and easy to read.

Rack-mount installation requires special 19" rack-mounted brackets and screws (included with each Magnum 6K32 unit). These brackets attach to the front sides of the Switch (regular package, i.e., not the Reverse version), which is then typically fastened into a standard 19" RETMA rack as shown here.



The 23" brackets and the ETSI (European metric, approx. 21") brackets are also available (optional) for rack-mounting of Magnum 6K32 Switches. These brackets are popular in the Telco industry where they are a standard for Central Office rack-mounting purposes. The 23" and the ETSI brackets are mainly used for larger equipment



**Fig 3.3.1 Mountings for Magnum 6K32 units rack-mounted in a frame**

assemblies in rack-mounting frames where the rack-mount equipment is typically accessed in operation from both sides.

The bracket mounting holes in the sides of the Magnum 6K32 permits it to be mounted in various ways. The same holes fit all three types (19", ETSI, 23") of brackets. The mounting for the 23" is illustrated in Figure 3.3.1 below. The brackets may be attached flush with the front, or attached in the center for a set-back mounting which may reduce cabling torque.

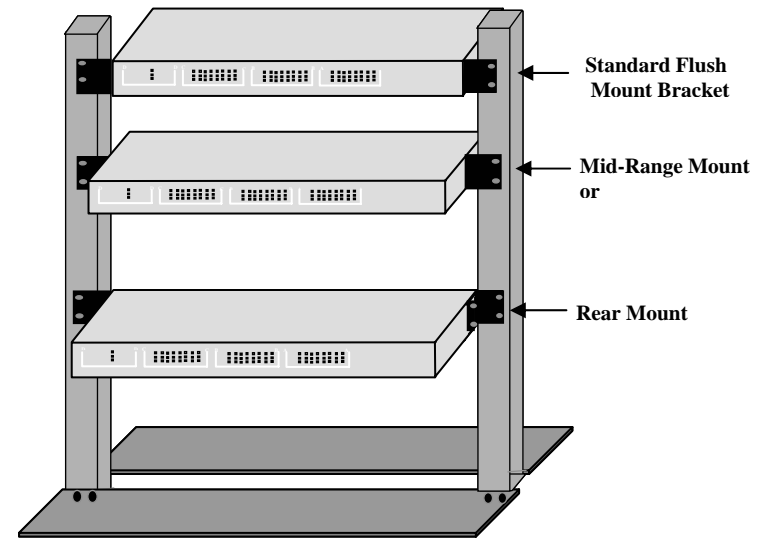
The optional 23" brackets and the ETSI (21") brackets each come as a pair in a package, along with the necessary screws for attaching the brackets to the sides of the Magnum Switch unit. They must be ordered as line items.

### 3.3.2 Rack-mounting, Reverse version of the Magnum 6K32s

The optional Reverse Magnum 6K32 Model has all of the cabling (Ethernet cabling, power cabling and console port cabling) connectors in the rear, and the status LEDs in the front. The status LEDs that are co-incident with the ports are still present there, and a second or dual set of LEDs are used for status visibility in the front of the unit, showing the same data.

There are three options of brackets available to mount in the standard 19" frame or the 23" frame or ETSI (21") frame. The 19" brackets are included with each unit, the other two may be purchased if desired.

With each bracket type, there are three different mounting options is shown in Fig. 3.3.2. The case of the Magnum 6K32 has mounting holes prepared for each of the mounting arrangements. Users may choose the mounting arrangement most suitable for their installation.



**Fig 3.3.2**  
**Reverse**  
**Magnum**  
**6K32 units,**  
**rack-**  
**mounted in**  
**a frame**

### 3.4 Powering the Magnum 6K32 Managed Switch

The Magnum 6K32 Switches incorporate an internal universal power supply and have a recessed male IEC connector for the AC power cord at the left-rear. A manual power ON-OFF switch is adjacent. A six-foot 115 VAC 60 Hz standard power cord is supplied with each unit shipped within the United States and Canada.

The auto-ranging power supply supports installation environments where the AC voltage is from 90 to 260 volts with a power input frequency between 47 and 63 Hz. The 32-port units will consume over 30 watts of power typically. When connecting the Ethernet cabling, there is no need to power down the unit. Individual segments can be connected or disconnected without concern for AC power-related problems or damage to the unit.

Power supply options are available to suit the 6K32 Switches to special high-availability communications and/or heavy industrial-grade applications, including:

- \* -48VDC, 24VDC and 125VDC with single DC input,
- \* -48VDC, 24VDC and 125VDC with dual-source DC input,

See the Appendices of this manual for more details. Use an RFQ for other variations.

#### 3.4.1 Alarm Contacts for monitoring internal power, and Software Traps

The Alarm Contacts feature, optional on Magnum 6K32's, provides two

Form C Normally Closed (NC) contacts to which the user can attach two sets of status monitoring wires at the green terminal block. When this option is present, the terminal block for Alarm Contacts is part of the Power Input panel in the Magnum 6K32 case. The AC or DC power input connection is in the same panel. A manual On-Off Switch for power to the unit is not available on 6K32 units with the Alarm Contacts option, as these two features occupy the same space in the case.

The first NC Alarm Contact (top position) is a “Software Alarm”, operated by user settings in the MNS-6K software. The user can disable the Software Alarm feature with a software configuration command if desired. When the Software Alarm is enabled, the Form C Normally Closed (NC) contact is held close during normal software operation. A user-defined software malfunction, such as an SNMP Trap or a Software Security violation or an S-Ring Fault, causes the contact to open and thus trigger an alarm in the user’s monitoring system

The second (bottom position) NC Alarm Contact is held close when there is power on the main board inside of the 6K32. This provides a “Hardware Alarm” because the NC contacts will open when internal power is lost, either from an external power down condition or by the failure of the power supply inside of the Magnum 6K32 Switch. Useful info. about Alarm contacts:

1. There is four terminal block (1,2,3,4) provided next to AC/DC power supply
2. The top two pins (1,2) are software operated
3. The bottom two pins (3,4) are hardware operated
4. By default it is NC (normally closed)
5. The software operation need to be enable and set to get the Alarm traps. For detail information about the Software Alarm and software control of SNMP alarm traps, please reference the Magnum MNS-6K Software User Manual. (Chapter 19th).

### 3.5 6K32 Port Module (6KPM) Installation

The Magnum 6K32 Switches are normally received from the factory with 24 ports fixed and one required 6KPM modules installed. There may be situations where 6KPM cards need to be added or replaced. In cases where a 6KPM module is desired to add in the modular slot, the faceplate for an available front-mounted slot must be removed. The following procedure describes this operation.

#### 3.5.1 Preparation for Installing and Removing 6KPMs

### **STOP!!!**

**Be sure the power cord is unplugged from the chassis before attempting to remove and/or replace any PM cards. Failure to do so may result in damage to the unit and will void the warranty.**



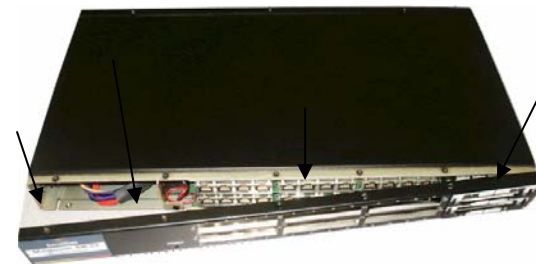
**Caution- Avoid Static Discharge: The port modules (like most electronic equipment) are sensitive to static discharge. Use proper ESD measures when handling port modules.**

**Step 1.** Make sure the 6KPM Card package has all necessary accessories to install it properly. Each 6KPM Card package, for field installation contains (Daughterboard (Bigger) and Granddaughter board (smaller), three 5/8 stand offs for Granddaughter board, six #4-40 Pan-Head screws along with Front panel face plate package. The Front panel faceplate package includes 3 retainer brackets and six #2-56 flat head screws.

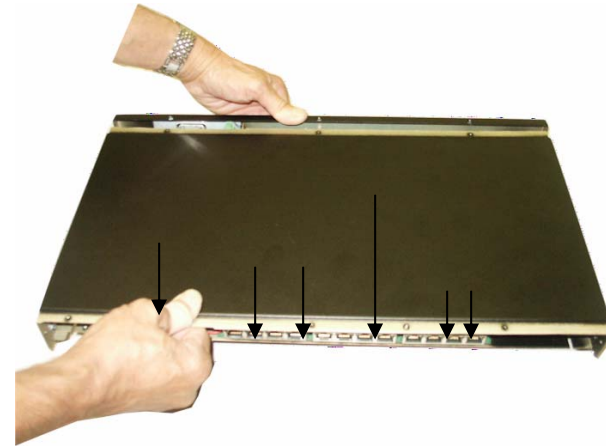
**NOTE:** *Every 6KPM Card package comes with their matching Daughter and Granddaughter board. The copper 6KPM card should not work properly if mixed with other Fiber combo 6KPM card packages. Always install the PM module separately one by one to avoid the mixing.*

**Step 2. Remove Chassis Cover**

The Magnum 6K32 chassis are combined with top, bottom and front panel parts and assembled together with the help of 17 Philips-head screws. There are 5 screws located on the front-bottom and 3 at rear-top of the unit and one each on the front and rear sides. First Remove the front panel screws (total 12) as shown in the fig 3.5.1a after the remove. Once these are removed, the front panel can be easily pulled out to the front. The top cover can be easily pulled off to the front from the chassis base, as shown in the Fig. 3.4.1b. When the chassis top cover has been removed, the interior of the unit is exposed.



**Figure 3.5.1a: Removing front panel after the screws being removed**



**Fig 3.5.1b: Pulling out the top cover from the chassis base**

**Caution: Be careful not to disturb the power supply.**

Looking down into the Magnum 6K32 unit, notice that there are individual PM installation spaces and female latch (white) connectors provided on the far right side of main board along with four stand-off's for 6KPM card position. (See Figure 3.5.1c).



**Figure 3.5.1c:  
Magnum 6K32's  
modular slot side  
(front-right side),  
without chassis  
cover**

### **Step 3. Remove front panel face plate retaining screws**

There are one PM slot located on the front-right side of the chassis cover. Looking into the vertical placed Chassis cover of the unit, there are one bracket with retaining screws

(#256 flat head ) which hold the PM Face plate card slot securely. These six screws shown in the picture below are used to secure a PM face plate in position, but unscrew only four of the screws as shown in Fig. below. These screws are also used to secure the individual 6KPM cards screen plate which can be subjected to significant forces from the attached cables. (See Figure 3.5.1d)

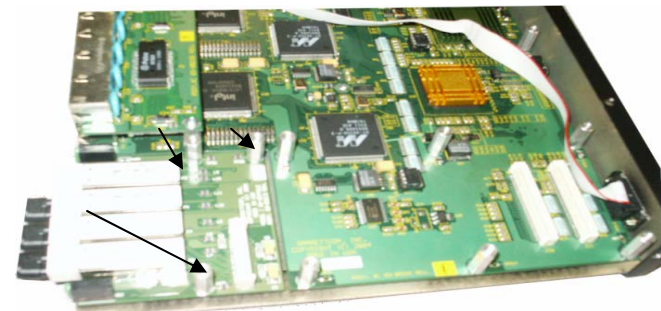


**Figure 3.5.1d: Top View – 6KPM retaining screws hold Face Plate**

### 3.5.2 Installing 6KPM Cards in the Magnum 6K32

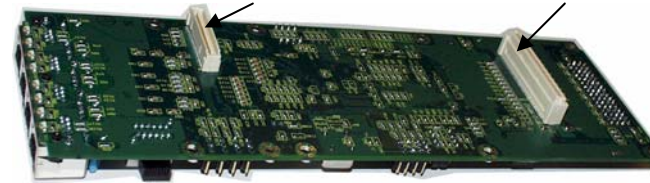
Up to four front-mounted 6KPM cards may be installed in one Magnum 6K32 Managed Switch unit. Follow these steps to install a 6KPM.

- Step 1.** Remove top chassis cover. See procedure in Section 3.5.1 above.
- Step 2.** Placed Granddaughter board (as shown in fig. 3.5.2a and 3.5.2b) on the chassis built in stand off (female) provided at the front of the 6K32 Main Board and screw down tightly with the three 5/16 stand-off (male) on the top of the Granddaughter board The 5/16 stand off has been used to place the daughter board on the top of the granddaughter board and latch it securely.

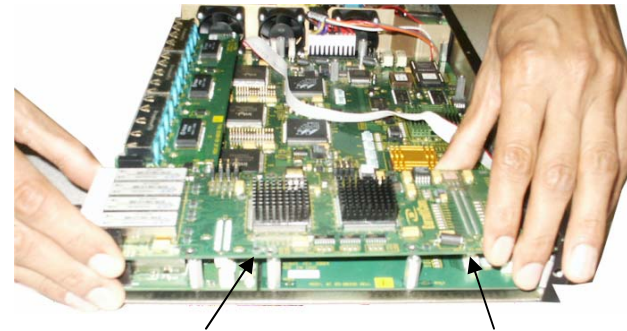


**Fig 3.5.2b Granddaughter Board placed in modular slot and secured with three 7/16 stand-off's as shown with arrow mark**

**Step 3.** The figure here illustrates the basic layout of an individual PM card. 6KPM card fits into the space provided on the main board over the grand-daughter Bd. and the male latched cream color connector( as shown in above fig. with arrow mark).



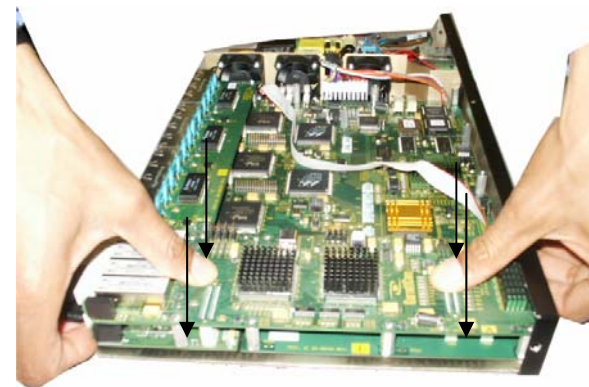
**Fig 3.5.2d: Daughter Board shown upside down with two male latch connectors**



**Fig 3.5.2e Daughter Bd. Being placed over the Grand daughter Bd. and the mating connector being matched to lockup properly**

**Step 4.** Hold the daughter board with both hands at the end and align the two cream color latching connectors (male) placed at the bottom of the daughter board with the other female connector placed on the Granddaughter and main board. As shown above in Fig. 3.5.2e

**Step 5.** Once the latching connectors are aligned properly and the mounting holes are aligned with stand offs then press slowly and firmly with two fingers (as shown



below in Fig. 3.5.2f) on the top of the latching connectors until the connectors latched up securely.

**Fig.3.5.2f:**

**Securely latching up 6KPM Cards into a Magnum 6K32**

**NOTE:.** *When leaving 6KPM slots empty, always use a face plate (Magnum 6K8-BLNK) to cover the slot opening in the front panel. This will maintain proper cooling air flow, safety, and operation as required by FCC, CE, and other regulations.*

**Step 6.** Now screw down the daughter board with 7 #440 screws except the last two at the end, so that it holds the daughter board securely. The figure below shows the top view of 6KPM card after successfully installing the 6KPM cards inside the Magnum 6K32.



**Fig. 3.5.2g Top View :  
6KPM Module installed  
inside a 6K32 Switch**

**Step 7.** Once the installation of granddaughter and daughter modules is done properly, the front panel screen plates (come along with the 6K-module) need to be properly placed on the front of the chassis cover to complete the installation process.

**Step 8.** Once the 6KPM cards have been installed, the chassis top cover should be replaced by matching at the two front corners properly and slide in until it reaches the rear end and fit properly to match the holes. Make sure the chassis cover is aligned properly before securing the enclosure. Place the front panel part at the end by sliding in to the front side and secure it with 12 screws as being mentioned earlier.

**NOTE (Reverse mount Model):** The Reverse model require a *LED Decal*, (for checking the speed, F/H, and activity status)

### 3.5.3 Removing 6KPM Cards

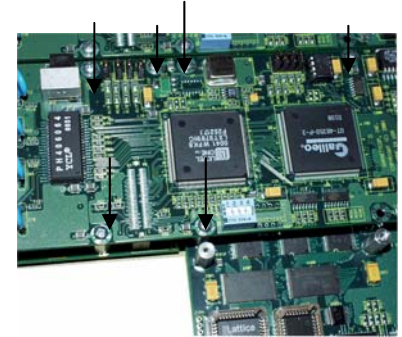
To properly remove a 6KPM card from the 6K32 Managed Switch, follow the 3 steps below.

**Step 1. Remove chassis cover** See procedures in Section 3.5.1 above.

**Caution: Be sure the power cord is unplugged.**

**Step 2. Remove retaining screws placed on top for the 6KPM and Face Plate**

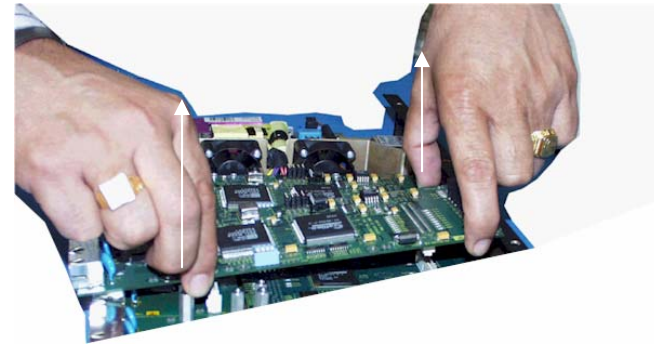
On the top of the daughter module there are six retaining screws for each 6KPM card. These screws are used to secure a 6KPM card in position (see Figure 3.5.3a). Remove the three standoff holding the Granddaughter board with the chassis. The screen faceplate screws out from the inside front of the chassis cover by loosening the 4 screws and bracket while holding it down firmly.

**Figure 3.5.3a: Top View**

- 6 retaining screws shown by arrows

**Step 3. Remove 6KPM Card**

Carefully and gently pull out the daughter board from the latching connectors, using both hands, gripping the board near the latch-up connectors as shown in Fig. 3.5.3b. If the now empty slot is to remain unused, be sure to install a 6KPM-BLNK face plate cover.

**Figure 3.5.3b:  
Removing a  
6KPM Card**

Follow the step 8 to complete the process successfully.

**NOTE:1.** *If the modular slot has not being used and moved to other unit, the empty slot must be covered with Blank cover, to maintain proper air-inflow inside the unit and keep off from dust and other unavoidable substance, otherwise can cause a failure in the Switch.*

**2.** *If the PM module in the modular slot is not being installed properly or loose in connection, the MNS-6K management software will not boot-up properly and a error will generate as -{ failed to read register device type (offset 0x1600) on slot "A or B or C or D"}}, whichever the slot has been used.*

**3.** *Always boot-up the Switch after any new module installation on modular slot to confirm the successful installation, before placing the chassis cover.*

### 3.6 Connecting the Console Terminal to Magnum 6K32 (Management)

Use a DB-9 “null modem” cable to connect the Magnum6K32 Console Port (the RS-232 port on the 6K32 Switch) to the your PC, so that your PC becomes the 6K32’s Console Terminal.

**Note: The DB-9 cable does not include with the 6K32 unit package.**

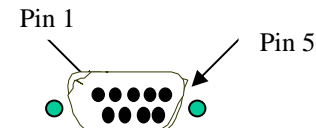
#### Console (DB-9) Port



Rear View of Magnum 6K32, (Typical Console Port is on the Rear of Reverse 6K32 Models)

*Note: For detail description of Managed Network Software (MNS-6K) and Magnum 6K32 Switch configuration for Network Management, please refer to [Magnum 6K32 Software Manual](#) available on GarrettCom’s FTP site. Detail info. about the MNS is available on 2.2.9 ( see page no. 13) of this manual.*

#### 3.6.1 RS-232 (DB-9) Console Com port (Serial port) pin assignments.



DB-9 (Console port connector)

Pin	Signal	Description
1	CD	Carrier detect (not used)
2	RXD	Receive Data (input)
3	TXD	Transmit Data (output)
4	open	not used
5	GND	Signal Ground
6-9	open	not used

The above provided information enables a managed station( a PC or Console terminal) to connect directly to the switch using a straight through cable.

**Note:** For using Console port to configure the managed switch, a serial (Null-modem) female to female cable is required to communicate properly. The Null-Modem (DB-9) cable is optional and can be order from the factory, along with the unit as-

CONSOLE CBL for serial port

CONSOLE USB for USB port

## 4.0 OPERATION

This chapter describes the functions and operation of the Magnum 6K32 Switch.

### 4.1 Switching Functionality

A Magnum 6K32 provides switched connectivity at Ethernet wire-speed among all of its ports. The Magnum 6K32 supports 10/100Mbps for copper media and 10 or 100Mb separate traffic domains for fiber ports to maximize bandwidth utilization and network performance. All ports can communicate to all other ports in a Magnum 6K32, but local traffic on a port will not consume any of the bandwidth on any other port.

Magnum 6K32 units are plug-and-play devices. There is no software configuring necessary to be done for basic operation at installation or for maintenance. The only hardware configuration settings are user options for an UP-LINK Switch (resides inside the unit) on the 6K8-RJ45 (modular port). Optional Half / Full duplex mode and 10 or 100Mbps selection for the switched ports must be configured through MNS-6K software per unit as per the requirement. The internal functions of both are described below.

#### Filtering and Forwarding

Each time a packet arrives on one of the switched ports, the decision is taken to either filter or to forward the packet. Packets whose source and destination addresses are on the same port segment will be filtered, constraining them to that one port and relieving the rest of the network from having to process them. A packet whose destination address is on another port segment will be forwarded to the appropriate port, and will not be sent to the other ports where it is not needed. Traffic needed for maintaining the operation of the network (such as occasional multi-cast packets) are being forwarded to all ports.

The Magnum 6K32 Switches operate in the store-and-forward switching mode, which eliminates bad packets and enables peak performance to be achieved when there is heavy traffic on the network.



### Address Learning

All Magnum 6K32 units have address table capacities of 4K node addresses suitable for use in larger networks. They are self-learning, so as nodes are added, removed or moved from one segment to another, the 6K32 Switch automatically keeps up with node locations.

An address-aging algorithm causes least-used addresses to fall out in favor of frequently-used addresses. To reset the address buffer, cycle power down-and-up.

## 4.2 Status LEDs

### For all Magnum 6K32 models :

- PWR** : Power LED, ON when external power is applied to the unit.
- LK** : Steady ON, Link status for 10 Mbps and 100Mbps operation.
- ACT** : ON with port activity for 10 Mbps and 100Mbps operation.
- F/H** : Full / Half duplex LED, ON when the port is running full duplex, OFF for half duplex.
- 100/10** : Speed LED, ON when the speed is 100Mbps , OFF when the speed is 10 Mbps

## 4.3 Up-link Cross-over Switch on RJ-45 port modules, for port#1 only

The modular slot provided on Magnum 6K32 managed switch can be filled with 6KP8-RJ45 port module among all the multiple choices of port modules. The upper part of the copper port module (6KP8-RJ45) has a manual Up-link switch, located on the inside of the unit on the port module board next to the RJ45 port # 1 which it controls. It enables the port's cable to be cascaded (X) to a 10/100Mb repeater or switching hub in the network. The manual Up-link switch position is configured as (=) position as default factory setting, where used for all-copper module or combo modules.

## 4.4 Auto-Cross (MDIX)Auto-negotiation, for 10/100Mbps RJ-45 ports

The 24 RJ-45 ports on Magnum 6K32 supports auto-cross (MDI or MDIX) in the auto-negotiation mode according to the IEEE 802.3u standard. No crossover cables are needed when connecting the 6K32's 10/100 copper ports to other unmanaged switches, legacy hubs, managed switches, media-converters etc. Please note that there can be conditions with managed switches where the switch manager fixes the port settings via software, and the result of the auto-negotiation is changed in the managed switch by the manager commands. In such cases, the 10/100 speed or the F/H mode may be affected, but auto-cross in the 6K32 Switches will still work. The auto-cross function can be disabled, if fixed the port at 10 or 100Mb through software..

The Managed Magnum 6K32 Fast Ethernet copper ports can be set for either fixed 100Mb speed or N-way auto-negotiation per the IEEE802.3u standard. The selection is made via 6K-MNS software. The factory default setting is for auto-negotiation. At 100Mb-fixed speed, the user may select half- or full-duplex mode by 6K-MNS Software for each RJ-45 port separately. For detail information see Section 8 (Optimizing Port usage) of Magnum 6K32 Software user guide (MNS-6K) . **See Section (2.2.9 at page no.14) of this manual to access the “MNS-6K Software user-guide”**

One frequently-used application for the Managed 6K32 Switch copper ports is to connect one of them using a fiber media converter to another Switch in the network backbone, or to some other remote 100Mb device. In this case, it is desirable to operate the fiber link at 100Mb speed, and at either half- or full duplex mode depending on the capabilities of the remote device. Standard commercially available Fast Ethernet media converters mostly do not support auto-negotiation properly, and require that the switched port to which they are connected be at 100Mb fixed speed. Attachment to 10/100 auto-negotiation ports typically will not work properly. The 6K32 Switch’s RJ-45 ports handle this situation by configuring the ports as per desire through MNS software port settings and can check the port status of each port after the change.

When Magnum 6K32 RJ-45 copper ports are set for auto-negotiation and are connected to another auto-negotiating device, there are 4 different speed and F/H modes possible depending on what the other device supports. These are: (1) 100Mb full-duplex, (2) 100Mb half-duplex, (3) 10 Mb full-duplex and (4) 10 Mb half-duplex.

General information -

**Auto-negotiation per-port for 802.3u-compliant switches occurs when:**

- the devices at both ends of the cable are capable of operation at either 10 Mb or 100Mb speed and/or in full- or half-duplex mode, and can send/receive auto-negotiation pulses, and . . .
- the second of the two connected devices is powered up\*, i.e., when LINK is established for a port, or
- the LINK is re-established on a port after being lost temporarily.

- **NOTE** – *Some NIC cards only auto-negotiate when the computer system*

*that they are in is powered up. These are exceptions to the “negotiate at LINK – enabled” rule above, but may be occasionally encountered.*

The auto-negotiation logic will attempt to operate in descending order and will normally arrive at the highest order mode that both devices can support at that time. (Since auto-negotiation is potentially an externally controlled process, the original “highest order mode” result can change at any time depending on network changes that may occur). If the device at the other end is not an auto-negotiating device, the 6K32’s RJ-45 ports will try to detect its idle signal to determine 10 or 100 speed, and will default to half-duplex at that speed per the IEEE standard.

When operating in 100Mb half-duplex mode, cable distances and hop-counts may be limited within that collision domain. The Path Delay Value (PDV) bit-times must account for all devices and cable lengths within that domain. For Magnum 6K32 Fast Ethernet switched ports operating at 100Mb half-duplex, the bit time delay is 50BT.

#### **4.5 Flow-control, IEEE 802.3x standard**

Magnum 6K32 Switches incorporate a flow-control mechanism for Full-Duplex mode. The purpose of flow-control is to reduce the risk of data loss if a long burst of activity causes the switch to save frames until its buffer memory is full. This is most likely to occur when data is moving from a 100Mb port to a 10 Mb port and the 10Mb port is unable to keep up. It can also occur when multiple 100Mb ports are attempting to transmit to one 100Mb port, and in other protracted heavy traffic situations.

Magnum 6K32 Switches implement the 802.3x flow control (non-blocking) on Full-Duplex ports, which provides for a “PAUSE” packet to be transmitted to the sender when the packet buffer is nearly filled and there is danger of lost packets. The transmitting device is commanded to stop transmitting into the 6K32 Switch port for sufficient time to let the Switch reduce the buffer space used. When the available free-buffer queue increases, the Switch will send a “RESUME” packet to tell the transmitter to start sending the packets. Of course, the transmitting device must also support the 802.3x flow control standard in order to communicate properly during normal operation. Note: When in Half-Duplex mode, the 6K32 Switch implements a back-pressure algorithm on 10/100 Mb ports for flow control. That is, the switch prevents frames from entering the device by forcing a collision indication on the half-duplex ports that are receiving. This temporary “collision” delay allows the available buffer space to improve as the switch catches up with the traffic flow.

#### 4.6 Power Budget Calculations for Magnum 6K32 PM's with Fiber Media

Receiver Sensitivity and Transmitter Power are the parameters necessary to compute the power budget. To calculate the power budget of different fiber media installations using Magnum products, the following equations should be used:

$$\text{OPB (Optical Power Budget)} = P_T(\text{min}) - P_R(\text{min})$$

where  $P_T$  = Transmitter Output Power, and  $P_R$  = Receiver Sensitivity

$$\text{Worst case OPB} = \text{OPB} - 1\text{dB}(\text{for LED aging}) - 1\text{dB}(\text{for insertion loss})$$

$$\text{Worst case distance} = \{ \text{Worst case OPB, in dB} \} / [\text{Cable Loss, in dB/Km}]$$

where the "Cable Loss" for 62.5/125 and 50/125 $\mu\text{m}$  (M.m) is 2.8 dB/km,

and the "Cable Loss" for 100/140 (Multi-mode) is 3.3 dB/km,

and the "Cable Loss" for 9/125 (Single-mode) is 0.5 dB/km

and the "Cable Loss" for 9/125 (Single-mode) is 0.4 dB/km (LXSC25)

and the "Cable Loss" for 9/125 (Single-mode) is 0.25 dB/km

(LXSC40)

and the "Cable Loss" for 9/125 (Single-mode) is 0.2 dB/km (LXSC70)

The following data has been collected from component manufacturer's (Agilent's and Lucent') web sites and catalogs to provide guidance to network designers and installers.

Fiber Port Module	Speed, Std.	Mode	Std. km fdx (hdx)	Wave - length nm	Cable Size $\mu\text{m}$	X'mitr Output $P_T$ , dB	R'cvr Sens. $P_R$ , dB	Worst OPB, dB	Worst* distance Km, fdx	typical OPB, dB	typical* distance Km, fdx
6KP4-F10ST	10Mb FL	Multi-Mode	2 (2)	850	62.5/125	-15.0	-31	14	5	17	6
					100/140	-9.5	-31	19.5	5.9	23.5	7
					50/125	-19.5	-31	19.5	3.4	13.5	4.8
6KPM-MST, MSC	100Mb FX	Multi-mode	2 (0.4)	1300	62.5/125	-20	-31	9.0	3.0	14	5
					50/125	-23.5	-31	5.5	2.0	12	4
6KPM-SSC	100Mb FX	Single-mode	18+ (0.4)	1300	9/125	-15	-31	14	28	17.5	35
6KPM-SSCL	100Mb FX	Single-mode	40 (0.4)	1300	9/125	-5	-34	29	58	32.5	65
6KPM-MTRJ	100Mb FX	Multi-mode	2 (0.4)	1300	62.5/125	-20	-31	9.0	3.0	15.8	5.5
					50/125	-23.5	-31	5.5	2.0	12.2	4.0
6KPM-MLC	100Mb FX	Multi-mode	2 (0.4)	1300	62.5/125	-19	-31	12	4	16	5.7
6KPM-SLC	100Mb FX	Single-Mode	15+ (0.4)	1310	9/125	-15	-28	11	22	-	-
GBIC-SXSC	1000Mb	Multi-mode	0.55	1300	62.5/125 50/125	-9.5	-17	5.5	2	12.5	4
GBIC-LXSC10	1000Mb	Single-mode	10	1300	9/125	-9.5	-20	8.5	17	10.5	21

GBIC-LXSC25	1000Mb	Single-mode	25	1550	9/125	-4.0	-21	15	37.5	17.5	43
GBIC-ZXSC40	1000Mb	Single-mode	40	1550	9/125	-4.0	-21	15	60	17.5	70
GBIC-ZXSC70	1000Mb	Single-mode	70	1550	9/125	-3.0	-23	18	90	20.5	102

\* **Note:** The use of either multi-mode or single-mode fiber to operate at 100Mbps speed over long distances (i.e., in excess of approx. 400 meters) can be achieved **only** if the following factors are both applied:

- The 100Mb fiber segment must operate in full-duplex (FDX) mode, i.e. the full-duplex (factory default) setting for 100Mbps fiber ports must be used, and
- The worst-case OPB of the fiber link must be greater than the fiber cable's passive Attenuation.

(Attenuation = Cable loss + LED aging loss + Insertion loss + safety factor)

## 5.0 Magnum 6K32 Managed Switch Port Modules

This chapter describes each Port Module (PM), including appearance, functionality, and status displays.

### 5.1 Inspecting the Package and Product

This section applies only to PMs shipped as separate items, i.e., 6K32 PMs not factory installed in a Magnum 6K32 modular slot.

Examine the shipping container for obvious damage prior to installing a 6K32 PM; notify the carrier of any damage you believe occurred during shipment or delivery. Inspect the contents of this package for any signs of damage and ensure that the items listed below are included.

This package should contain:

6K32 PMs

Installation instructions, with illustrations

Remove the 6K32 PM(s) from the shipping container. Be sure to keep the shipping container should you need to ship any of the PMs separately at a later date. In the event there are items missing or damaged, contact your supplier. If you need to return the unit, use the original shipping container if possible. Refer to Chapter 5 for specific return procedures.

## 5.2 6KPM Module Description

An important feature of the Magnum 6K32 is the use of one Port Modules for flexible mixed-media connectivity to RJ-45 and fiber media in the modular slot. Since the Magnum 6K32 Switches have dual-speed capability for copper ports, the 6 or 8-port interfaces are designed to support all standard Ethernet media types at 10 or 100Mbps speed. Each 6K32 PM can provide two, four, six or eight ports for connecting Ethernet segments with its individual connector type and media.

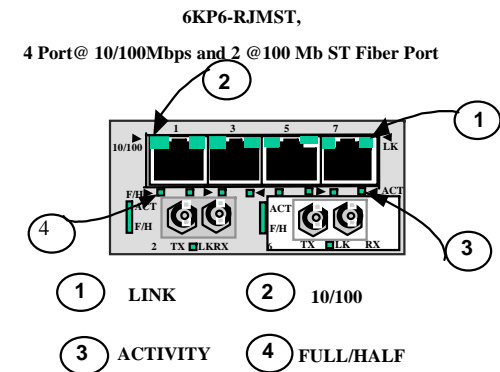
For a list of 6K32 Port Module types, refer to Section 1.2

Each 6K PM is individually described in the following sections.

**NOTE:** The port #1 on the RJ-45 ports on all the modules, either all RJ-45 ports or used for COMBO module is set as (=) as other ports.

### 5.2.1 6KP6-RJMST, 4@10/100Mbps RJ-45 and 2@100Mb multi-mode FX-ST “twist lock” Combo Module

The Magnum 6KP6-RJMST is a combo 6 port module of RJ-45's at 10/100Mbps and fiber optic ports at 100MB. The Combo module is equipped with dual-mode ST-type connectors and dual speed copper ports. The ST-connector functions as a fiber optic transceiver to support 100BASE-FX network segments. When installed in a Magnum 6K32 Managed Switch, the copper port supports the standard distance 100m on each port and the fiber port supports fiber optic cable distances up the IEEE-standard 100Mbps distance limits, i.e., typically 2km at full-duplex and 412m at half-duplex.



Each port has an Activity (ACT) LED indicating packets being received, a Link (LK) LED that indicates proper connectivity with the remote device when lit, and FDX/HDX LED to indicate full-duplex mode when lit (or half-duplex when off). The

10/100 LED indicates the speed, if the LED is ON 100Mbps if it is OFF 10Mbps.

### 5.2.1a 6KP6-RJ10ST, 4@10/100Mbps RJ-45 and 2@10Mb multi-mode FX-ST “twist lock” Combo Module

The 6KP6-RJ10ST is a six port combo module that looks similar to the 100Mb combo module with the exception of 10Mb speed at the ST fiber module. The ST-connector functions as a fiber optic transceiver to support 10BASE-FX network segments. When installed in a Magnum 6K32 Managed Switch, the copper port supports the standard distance 100m on each port and the fiber port supports fiber optic cable distances up the IEEE-standard 10Mbps distance limits, i.e., typically 2km at full-duplex and half-duplex.

Each port has an Activity (ACT) LED indicating packets being received, a Link (LK) LED that indicates proper connectivity with the remote device when lit, and FDX/HDX LED to indicate full-duplex mode when lit (or half-duplex when off). The 10/100 LED indicates the speed, if the LED is ON, 100Mbps if it is OFF, 10Mbps.

### 5.2.1b 6KP4-F10ST, 4@10Mb multi-mode FX-ST “twist lock” Module

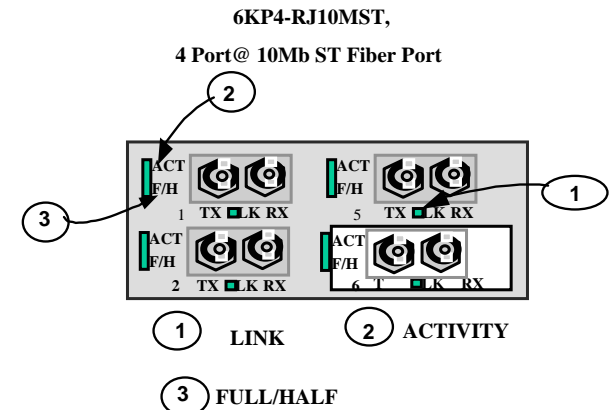
The Magnum 6KP4-F10ST

is a 10Mb multi-mode fiber module with 4 ST-Fiber ports. All four fiber ports are ST connectors and configured as 10Mb Half-duplex by default. The 10Mb ST-fiber ports allow the user to connect their legacy 10Mb network to the Magnum 6K32

switch. They also provide a convenient way for the half duplex

hub to connect to the switch through 10Mb fiber ports. It supports distances according to the 10Base-FL standard i.e, 2Km distance for multi-mode fiber. (Single-mode for 10Km distance may be available as a special order).

Each port has an Activity (ACT) LED indicating packets being received, a Link (LK) LED indicating proper connectivity with the remote device when lit, and FDX/HDX LED indicating full-duplex mode when lit (or half-duplex if off).

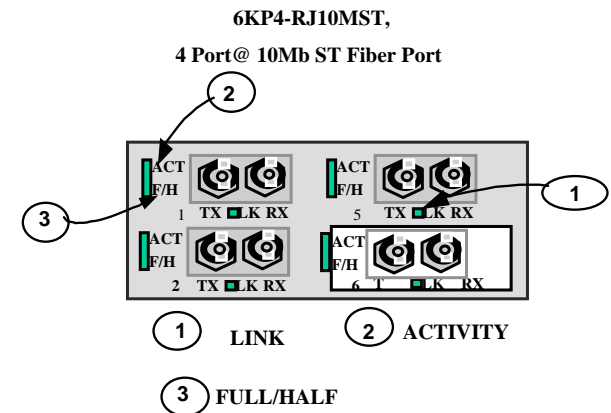


### 5.2.1c 6KP4-FLSTFX, 2@10Mb and 2@100Mb multi-mode FX-ST “twist lock” Module

The Magnum 6KP4-FLSTFX is a combo fiber module with two 10Mb + two 100Mb multi-mode fiber module and in combine 4 ST-Fiber ports. All four fiber ports are ST connectors and configured as 10Mb Half-duplex by default for 10Mb fiber and 100Mb Full duplex for the

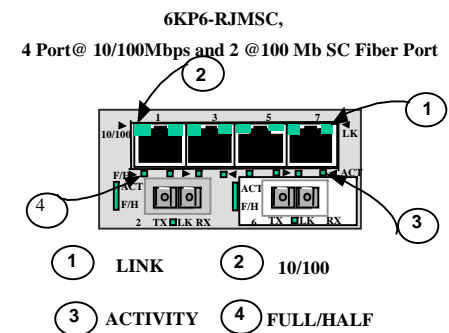
100Mb fiber. The 10Mb ST-fiber ports allow the user to connect their legacy 10Mb network to the Magnum 6K32 switch. They also provide a convenient way for the half duplex hub to connect to the switch through 10Mb fiber ports. Whereas the 100Mb ST module allow to connect the 100Mb demand of Switch devices. It supports distances according to the 10Base-FL standard i.e, 2Km distance for multi-mode fiber. (Single-mode for 10Km distance may be available as a special order).

Each port has an Activity (ACT) LED indicating packets being received, a Link (LK) LED indicating proper connectivity with the remote device when lit, and FDX/HDX LED indicating full-duplex mode when lit (or half-duplex if off).



### 5.2.2. 6KP6-RJMSC 4@10/100Mbps RJ-45 and 2@100Mb multi-mode FX-SC “snap-in” Fiber connector

The Magnum 6KP6-RJMSC is also a Combo 6 Port module equipped with 4 10/100Mb RJ-45 ports along with 2 multi-mode 100Mbps fiber optic transceivers all in one module. This is similar to the 6K6-RJMST. It has the same LEDs indicating port activity (ACT), Link (LK), and



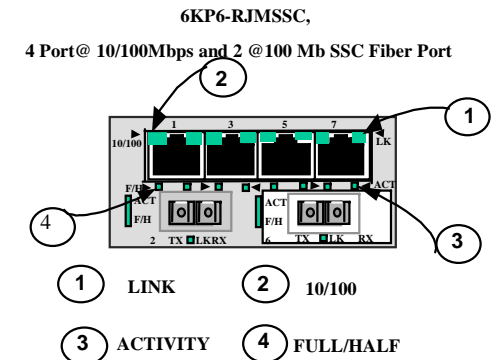


FDX / HDX and 10/100 operation, and the same face-plate lettering.

While the functionality of these two modules is essentially the same, the 6KP6-RJMSC is equipped with an SC-type "snap-in" connector instead of an ST-type.

### 5.2.3 6KP6-RJSSC 4@ 10/100Mbps RJ-45 Ports and 2@100Mbps single-mode FX-SC-type, "snap-in" connector

The Magnum 6KP6-RJSSC is also a Combo module equipped with 4 dual speed copper ports and 2 Single-mode SC-type connectors. It provides an advantage through combining copper and Fiber functions in one module of the 6K32 Switch supporting four Copper and two single-mode fiber network segments.



The 6KP6-RJSSC, when installed in a Magnum 6K32 Switch operates on copper at the 100m distance. The Fiber is single-mode and cable lengths can be as much as 25+ Km (see Power Budget, Section 4.5)

Each port has an Activity (ACT) LED indicating packets being received, a Link (LK) LED that indicates proper connectivity with the remote device when lit, and a FDX/HDX LED to indicate full-duplex mode when lit (or half-duplex when off). The 10/100 LED indicates 100Mbps speed when lit and 10Mbps speed when off. To distinguish the single-mode 6 K6-RJSSC from the multi-mode 6K6-RJMSC, the label "Sgl. M." is at the top of the faceplate of the 6K6-RJSSC.

### 5.2.4 6KP6-RJSSCL 4 @ 10/100 Mb copper port and 2@100Mbps single-mode FX-SC-type, "snap-in" connector

The Magnum 6KP6-RJSSC is also a Combo module equipped with 4 dual speed copper ports and 2 Single-mode (Long Reach) SC-type connectors. It provides a combination of copper and Fiber functions in one module to the 6K32 Switches, supporting four Copper and two single-mode (Long-Reach) fiber network segments.

The 6KP6-RJSSC, when installed in a Magnum 6K32 Switch has copper

supporting the 100m distance and Fiber supporting single-mode fiber cable lengths of as much as 40+ Km (see Power Budget, Section 4.5)

Each port has an Activity (ACT) LED indicating packets being received, a Link (LK) LED indicating proper connectivity with the remote device when lit, and a FDX/HDX LED indicating full-duplex mode when lit (or half-duplex when off). The 10/100 LED indicates the speed for the copper port, which is 100Mbps when the LED is ON and 10 Mb when the LED is OFF.

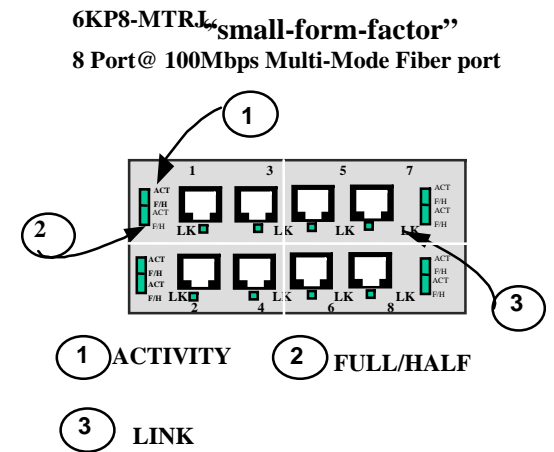
#### **5.2.4a 6KP6-RJ10ST 4 @ 10/100 Mb copper port and 2@10Mbps multi-mode FL-ST-type, “twist-lock” connector**

The Magnum 6KP6-RJ10ST is also a Combo module equipped with 4 dual speed copper ports and 2 multi-mode 10 Mb fiber ST-type connectors. It provides a combination of copper and Fiber functions in one module to the 6K32 Switches, supporting four Copper and two 10Mb of ST fiber network segments.

The 6KP6-RJ10ST, when installed in a Magnum 6K32 Switch has copper supporting the 100m distance and Fiber supporting multi-mode fiber cable allow to connect the legacy network of 10Mb requirement in the network. Each port has an Activity (ACT) LED indicating packets being received, a Link (LK) LED indicating proper connectivity with the remote device when lit, and a FDX/HDX LED indicating full-duplex mode when lit (or half-duplex when off). The 10/100 LED indicates the speed for the copper port, which is 10Mbps when the LED is ON and 10 Mb when the LED is OFF.

### 5.2.5 6KP8-MTRJ, 8 @100Mb multi-mode FX , MTRJ Small-Form-factor

Magnum 6KP8-MTRJ is a multi-mode fiber optic 8-port module equipped with a small-form-factor MTRJ-type connector. It looks almost like an RJ-45 port, but it is black in color. The MT-RJ's small size and ease of connection make it a good choice for 100Mbps "fiber-to-the-desktop" Ethernet connectivity. When installed in a Magnum 6K32 Switch, it supports fiber optic cable distances up to the IEEE-standard 100Mbps distance limits, i.e., typically 2km at full-duplex and 412m at half-duplex.



The functionality of this 100BASE-FX multi-mode 8 Port module is essentially the same as the ST and SC-types. It has the same LEDs per port indicating port activity (ACT), Link (LK), and FDX or HDX operation.

#### 5.2.5a 6KP6-MT10ST, 4 @100Mb multi-mode FX , MTRJ Small-Form-Factor and 2@ 10Mb Multi-mode ST-Fiber port

The 6KP6-RJ10ST is a combo module with two different kinds of fiber flavor with two different speeds. The top four ports of MTRJ Small form factor fiber support at 100Mb full-duplex, whereas the bottom two ports multi-mode ST-Fiber support 10Mb half-duplex. This combo module provides more flexibility to the user to connect their legacy 10Mb fiber as well as 100Mb to the Magnum 6K32 Switch.

When installed in a Magnum 6K32 Switch, the 100Mb MTRJ connector supports fiber optic cable distances up to the IEEE-standard 100Mbps distance limits, i.e., typically 2km at full-duplex and 412m at half-duplex. The 10Mb Multi-mode ST-Fiber connector supports the standard fiber optic distance limit of 2Km at Full and Half-duplex both.

The functionality of this 100BASE-FX multi-mode 4 port module is essentially the same as the ST and SC-types. It has the same LEDs per port

indicating port activity (ACT), Link (LK), and FDX or HDX operation

### 5.2.6 6KP8-45MT, 4@ 10/100Mbps RJ-45 and 4@ 100Mb multi-mode FX ,

#### MTRJ Small-Form-Factor

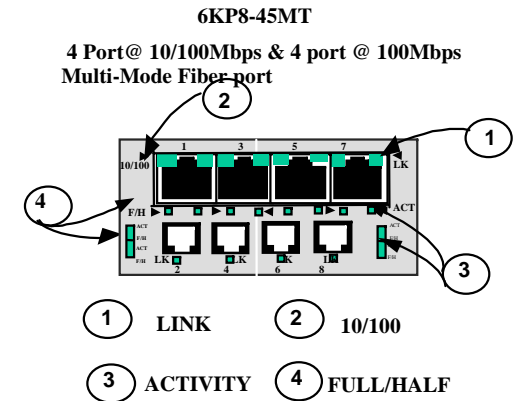
The Magnum 6KP8-45MT

Module is a combo module with copper and fiber (Small Form Factor) MTRJ type ports. The small size of MTRJ connectors give an advantage of placing more ports on one module. The 6KP8-45MT is equipped with 4 10/100 RJ-45 ports and 4 MTRJ fiber ports.

When installed in a Magnum 6K32

Switch, it supports the standard

distances as mentioned on 5.2.3. and the LEDs also act similarly.



### 5.2.7 6KP8-MLC, 8 ports @ 100Mbps multi-mode LC connector Small-Form Factor

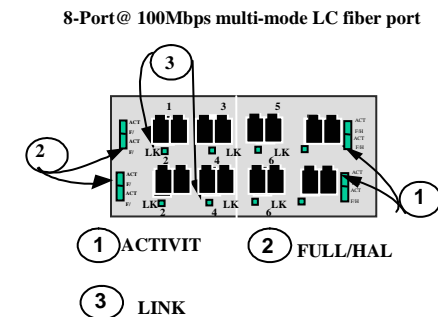
Magnum 6KP8-MLC is an eight-port multi-mode fiber LC connector “small-form-factor” used primarily in 100Mbps fiber-to-the-desktop links. When installed in a Magnum 6K32 Switch, it supports fiber optic cable distances up to the IEEE-standard 100Mbps distance limits, i.e., typically 2km at full-duplex and 412m at half-duplex.

The compact size of the LC

Connector reduces the size of wiring panels

in wiring closets while providing the advantage of “future-proof” fiber optic technology.

The cable end is a “plug-in” connector with both fiber strands terminated in one housing that cannot be improperly inserted. Each port has an Activity (ACT) LED indicating packets being received, a Link (LK) LED indicating proper connectivity with the remote device when lit, and a FDX/HDX LED indicating full-duplex mode when lit

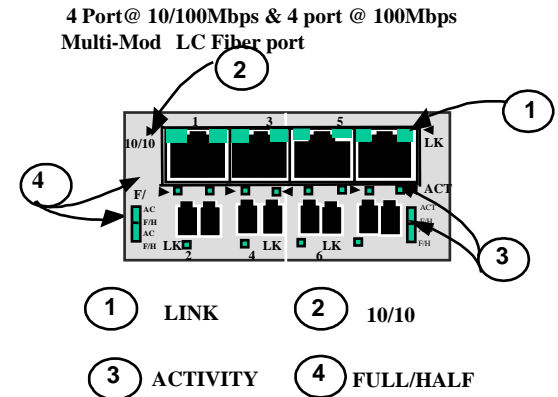


(or half-duplex when off).

### 5.2.8 6KP8-45LC, Combo 4@ 100Mbps multi-mode -LC small-form factor and 4@ 10/100 Mbps RJ-45 Connector

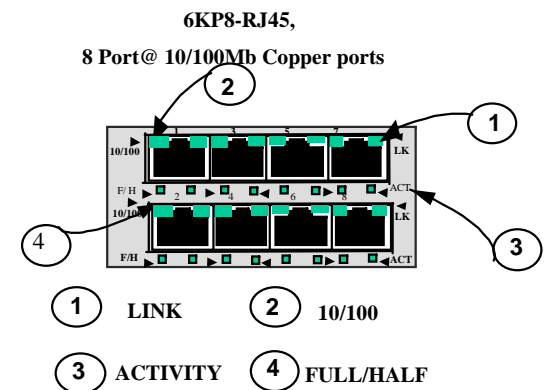
The Magnum 6KP8-45LC Module is a combo module with a combination of copper and Fiber (Small Form Factor) LC type ports. The small size of LC connectors allows an advantage of having more ports on one module. The 6KP8-45LC is equipped with 4 10/100 RJ-45 ports and 4 LC (Small form factor) multi-mode fiber ports.

When installed in a Magnum 6K32 Switch, it supports the standard distances as per mentioned on 5.2.8. and the LEDs also acts similarly as mentioned above.



### 5.2.9 6KP8-RJ45 (Twisted Pair), 10/100Mb 8-Port

The 6KP8-RJ45 module supports Ethernet twisted pair segments of any standard length. It is equipped with an eight-port RJ-45 connector, and offers 10/100 full / half-duplex auto-negotiating capability on each port. The RJ-45 connector is shielded to minimize emissions and will allow both unshielded twisted pair (UTP) and shielded twisted pair (STP) cable connections. The 6KP8-RJ45 module is equipped with a Media Dependent Interface-Crossover (MDI-X) switch, which controls port#1 for cascaded connection. This feature eliminates the need for a



special twisted pair crossover cable when connecting to a hub or another switch.

The switch is configured as (=) position by default settings from the factory, the left-most RJ-45 port is used for segments going to workstations and other user node device connections as other ports of the module. For cascaded and up-link connections (i.e.: a connection to another hub or switch typically), the uplink switch should be in the OUT (X) position.

Each port has an Activity (ACT) LED indicating packets being received, a Link (LK) LED that indicates proper connectivity with the remote device when lit, a FDX/HDX LED to indicate full-duplex mode when lit (or half-duplex when off), and a “10/100” LED indicating 100Mb when lit (or 10 Mbps when off).

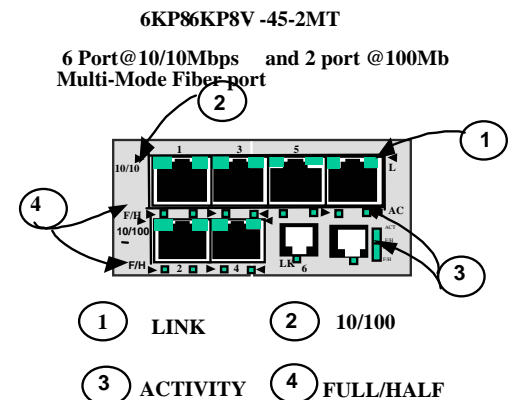
**Important Note:** For the 6KP8-RJ45 Crossover Switch-Inside is set for (=) by default from the factory for the Port # 1 and act similar as other user port. The location of cross-over switch can be seen in the fig 3.5.2.c (RJ-45 module) at page no 27.

The RJ-45 pins normally (TP crossover switch) are per the standard for hubs-to-users twisted pair wiring: 1 = receive+, 2 = receive-, 3 = transmit+, 6 = transmit-, other pins not used. When the TP crossover push-button is UP, the pins of the RJ-45 port are per the standard for up-links using twisted pair wiring, i.e., the transmit and the receive pairs are exchanged: 1 = transmit+, 2 = transmit-, 3 = receive+, 6 = receive-, other pins not used.

### 5.2.10 6KP8-45-2MT, 6@ 10/100Mbps RJ-45 and 2@100Mb multi-mode FX , MTRJ Small-Form-Factor

The Magnum 6KP8-45-2MT eight port Module is a combo module with copper and fiber (Small Form Factor)

MTRJ type ports. The small sizes of MTRJ connectors give an advantage of placing more fiber ports on one module. The 6KP8-45-2MT is equipped with six 10/100 RJ-45 ports and two 100Mb MTRJ fiber ports. When installed in a Magnum 6K32 Switch, it supports the standard distances as mentioned on 5.2.3. and the LEDs also act similarly.



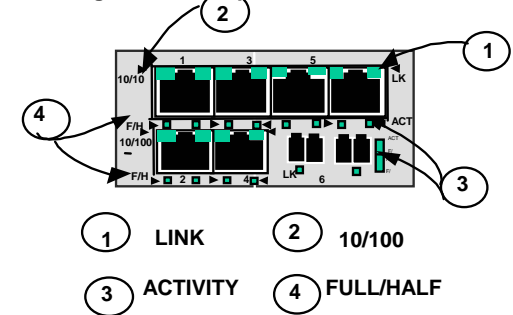
### 5.2.10a 6KP8-45-2LC, 6@ 10/100Mbps RJ-45 and 2@100Mb single-mode

**FX , LC Small-Form-Factor**

The Magnum 6KP8-45SLC eight port Module is a combo module with copper and fiber (Small Form Factor) LC type fiber ports.

The small size of LC connectors give an advantage of placing more ports on one module. The 6KP8-45-2SLC is equipped with 6 10/100 RJ-45 ports and 2 Single-mode fiber ports.

When installed in a Magnum 6K32 Switch, it supports the standard distances as mentioned on 5.2.4. and the LEDs also act similarly.

**6KP8-45-2SLC****6 Port @ 10/100Mbps & 2 port @ 100Mbps****Single Mode Fiber port****5.2.11 GBIC-SXSC Gigabit fiber(1000Mb), multi-mode SC Connector**

The Magnum GBIC-SXSC is a multi-mode Gigabit fiber connector equipped with SC type connectors and can be easily snapped in and out. The Gigabit fiber ports are most popular as server-to-switch and switch-to-switch applications. It supports cable distances up to the IEEE 802.3z standard 1000Mbps distance limits, i.e., 550m at full duplex.

**1 @ 1000Mb Fiber SC + 4 @ 10/ 100Mb**

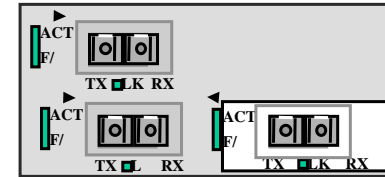
The GBIC transceiver has been offered in the modular slot with multiple options as per the user requirement. The two Giga port has been offered as GBPM-2OTX (fiber or RJ-45), whereas the single Gigabit module comes in flavor of G+2 (100Mb fiber ports) or G+4(10/100 RJ-45 ports) as shown in the above figure.

The GBIC transceiver is fastened using snap-in clips. Insert the transceiver (take care to insert it the right way up, arrows on top) until it clicks in space. While removing the transceiver, press the clips on either side of the transceiver at the same time and pull the transceiver out.

Each port has an Activity (ACT) LED indicating packets being received and a Link (LK) LED indicating proper connectivity with the remote device when lit.

### 5.2.11a GBIC-LXSC Gigabit fiber (1000Mb), multi-mode SC Connector

The Magnum GBIC-LXSC is a single-mode Gigabit fiber connector equipped with SC type connectors and can be easily snapped in and out. The Gigabit fiber ports are most popular as server-to-switch and switch-to-switch applications. It supports cable distances up to the IEEE 802.3z standard 1000Mbps distance limits, i.e., 10,25, 40 or 70Km at full duplex, and depend upon the Gigabit modules used.



1@ 1000Mb Fiber SC + 2@ 100Mb SC

The two Giga port has been offered as GBPM-2OTX (fiber or RJ-45), whereas the single Gigabit module comes in flavor of G+4(10/100 RJ-45 ports) or G+2 (100Mb fiber ports) as shown below in the above figure.

Each port has an Activity (ACT) LED indicating packets being received and a link (LK) LED indicating proper connectivity with the remote device when lit.

### 5.2.12 6KM-BLNK

The 6K8-BLNK is a blank face plate or cover plate that must be installed in any empty 6K32 PM slot to maintain proper cooling air flow, safety, etc.

Two screws underneath the front panel hold the 6KM-BLNK in place.



## 6.0 TROUBLESHOOTING

All Magnum Ethernet products are designed to provide reliability and consistently high performance in all network environments. The installation of a Magnum 6K32 Switch is a straightforward procedure (see INSTALLATION, Section 3.0); the operation is also straightforward and is discussed in Section 4.

Should problems develop during installation or operation, this section is intended to help locate, identify and correct these types of problems. Please follow the



suggestions listed below prior to contacting your supplier. However, if you are unsure of the procedures described in this section or if the Magnum 6K32 Switch is not performing as expected, do not attempt to repair the unit; instead contact your supplier for assistance or contact GarrettCom Customer Support.

### **6.1 Before Calling for Assistance**

1. If difficulty is encountered when installing or operating the unit, refer back to the Installation Section of the applicable chapter of this manual. Also check to make sure that the various components of the network are interoperable.
2. Check the cables and connectors to ensure that they have been properly connected and the cables/wires have not been crimped or in some way impaired during installation. (About 90% of network downtime can be attributed to wiring and connector problems.)
3. Make sure that an AC power cord is properly attached to each Magnum 6K32 Switch unit. Be certain that each AC power cord is plugged into a functioning electrical outlet. Use the PWR LEDs to verify each unit is receiving power.
4. If the problem is isolated to a network device other than the Magnum 6K32 Switch product, it is recommended that the problem device be replaced with a known good device. Verify whether or not the problem is corrected. If not, go to Step 5 below. If the problem is corrected, the Magnum 6K32 Switch and its associated cables are functioning properly.
5. Always check your Switch configuration, specially Auto-negotiation behavior with other connected device to have proper setup tested.
5. If the problem continues after completing Step 4 above, contact your supplier of the Magnum 6K32 Switch unit or if unknown, contact GarrettCom, Inc. by fax, phone or email ([support@garrettcom.com](mailto:support@garrettcom.com)) for assistance.

### **6.2 When Calling for Assistance**

Please be prepared to provide the following information.

1. A complete description of the problem, including the following points:
  - a. The nature and duration of the problem;
  - b. Situations when the problem occurs;
  - c. The components involved in the problem; (complete Network diagram

preferred)

- d. Any particular application, environment, power spike that, when used, appears to create the problem;
2. An accurate list of GarrettCom product model(s) involved, with serial number(s). Include the date(s) that you purchased the products from your supplier.
3. It is useful to include other network equipment models and related hardware, including personal computers, workstations, terminals and printers; plus, the various network media types being used.
4. A record of changes that have been made to your network configuration prior to the occurrence of the problem. Any changes to system administration procedures should all be noted in this record.

### 6.3 Return Material Authorization (RMA) Procedure

All returns for repair must be accompanied by a Return Material Authorization (RMA) number. To obtain an RMA number,

<http://www.garrettcom.com/techsupport/RMA/rma.htm>

Or call GarrettCom Customer Service at (510) 438-9071 during business hours in California or email to [support@garrettcom.com](mailto:support@garrettcom.com)). When calling, please have the following information readily available:

Name and phone number of your contact person.

Name of your company / institution

Your shipping address

Product name

Serial Number (or Invoice Number)

Packing List Number (or Sales Order Number)

Date of installation

Failure symptoms, including a full description of the problem.

GarrettCom will carefully test and evaluate all returned products, will repair products that are under warranty at no charge, and will return the warranty-repaired units to the sender with shipping charges prepaid (see Warranty Information, Appendix A, for complete details). However, if the problem or condition causing the return cannot be duplicated by GarrettCom, the unit will be returned as:

#### **No Problem Found.**

GarrettCom reserves the right to charge for the testing of non-defective units under warranty. Testing and repair of product that is not under warranty will

result in a customer (user) charge.

#### 6.4 Shipping and Packaging Information

Should you need to ship the unit back to GarrettCom, please follow these instructions:

1. Package the unit carefully. It is recommended that you use the original container if available. Units should be wrapped in a "bubble-wrap" plastic sheet or bag for shipping protection. ( You may retain all connectors and this Installation Guide.)

**CAUTION: Do not pack the unit in Styrofoam "popcorn" type packing material. This material may cause electro-static shock damage to the unit.**

2. Clearly mark the Return Material Authorization (RMA) number on the outside of the shipping container.
3. GarrettCom is not responsible for your return shipping charges.

4. Ship the package to:

**GarrettCom, Inc.**

**213 Hammond Ave.**

**Fremont, CA 94539**

**Attn.: Customer Service**

#### APPENDIX A: WARRANTY INFORMATION

GarrettCom, Inc. warrants its products to be free from defects in materials and workmanship for a period of three (3) years from the date of shipment by GarrettCom.

During this warranty period, GarrettCom will repair or, at its option, replace components in the products that prove to be defective at no charge other than shipping and handling, provided that the product is returned pre-paid to GarrettCom.

This warranty will not be effective if, in the opinion of GarrettCom, the product has been damaged by misuse, misapplication, or as a result of service or modification other than by GarrettCom.

GarrettCom reserves the right to make a charge for handling and inspecting any product returned for warranty repair which turns out not to be faulty.

Please complete the warranty card as this acts as a product registration, and mail it to GarrettCom within two weeks of your purchase.

#### **APPENDIX B : Internal DC Power Supply Options**

##### **B1.0 SPECIFICATIONS FOR MAGNUM 6K32 SWITCHES, DC POWER**

##### **Power Supply (Internal -48VDC Option)**

DC Power Connector: 3 terminals: “-“, “GND”, “+”

Input Voltage: 36 - 70 VDC

Power Consumption: Same as for AC models (see Section 1.1)

#### Power Supply (Internal 24 VDC Option) Industrial Applications

DC Power Connector: 3 terminals: “-“, “GND”, “+”

Input Voltage: 20 - 36 VDC

Power Consumption: Same as for AC models (see Section 1.1)

#### Power Supply (Internal 125 VDC Option) Industrial Applications

DC Power Connector: 3 terminals: “-“, “GND”, “+”

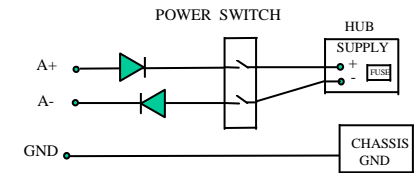
Input Voltage: 88 - 150 VDC

Power Consumption: Same as for AC models (see Section 1.1)

**With the exception of the power supply, all specifications and functions of Magnum 6K32 Switch -48VDC, 24VDC and 125VDC models are identical to those listed in the main manual.**

### B2.0 -48VDC, 24VDC and 125VDC POWER, THEORY OF OPERATION

The -48VDC, 24VDC and 125VDC power options are designed using diodes inside on each DC power input line behind the two external power connection terminals, so that the power from an external source can only flow into the hub. This allows the Switch to operate only whenever DC power is correctly applied to the two inputs.



It protects the Switch from incorrect DC input connections. An incorrect polarity connection, for example, will neither affect the Switch, its internal power supply, nor will it blow the fuse in the internal power supply.

The manual power “On-Off” Switch (optional) is used for powering the unit on and off when it is placed into or taken out of service.

### B3.0 APPLICATIONS FOR DC POWERED SWITCHES

Magnum 6K32 Fiber Switches are easily installed in a variety of applications where -48VDC, 24VDC and 125VDC power is used as the primary power source. The -48VDC, 24VDC and 125VDC power configuration provides an Ethernet networking solution utilizing a special power supply in a Managed Switch.

The -48VDC solution is particularly useful in the telecommunication industry, where it is common for facilities to operate on -48VDC power. Such companies include regular and wireless telephone service providers, Internet Service Providers (ISPs) and other communication companies. In addition, many high availability equipment services, such as broadcasters, publishers, newspaper operations, brokerage firms and other facilities often use a battery backup system to maintain operations in the event of a power

failure. It is also frequently used for computer system backup, management and operations monitoring equipment.

The 24VDC and 125VDC solution are particularly useful in the Industrial environment, where it is common facilities to operate on 24VDC or 125VDC power. The 125VDC solution is mainly used in power utilities, such as electrical substations, electrical generating plants, etc. The 24VDC applications are mainly in the Industrial environment, such as factory floor, HVAC equipment, military equipment, etc.

#### **B4.0 INSTALLATION**

This section describes the installation of the -48 VDC, 24VDC and 125VDC power source leads to the -48 VDC, 24VDC and 125VDC power terminal block on the Magnum 6K32s. (see figure at right).

In this picture, the -48VDC terminal block on the Magnum 6K32 is located on the rear of the unit and is equipped with three (3) screw-down lead posts. It is similar for 24VDC and 125VDC options on Magnum 6K32. The leads are identified as negative (-), positive (+), and chassis ground (GND).

##### **Figure B4.0: -48VDC Terminal Block on Magnum 6K32-48VDC**

The actual connection procedure is very straightforward. Simply connect the leads to the Magnum unit, beginning with ground. Ensure that each lead is securely tightened.

*Note: The GND should be hooked up first. The 6K32 unit has a floating ground, so the user may elect to Ground either + or = terminal to suit the customer's use.*

*Before connecting hot lines to the Terminal Block of -48VDC, 24VDC or 125VDC, always use a digital voltmeter to measure the output voltage of the power supply and determine the lead which is more "+ve potential". The more "+ve" voltage lead from 48V or -48V supply must be connected to the post labeled "+".*

An ON-OFF manual switch is optional for DC power. This can be used to cut off power connections and as a RESET for the Magnum 6K32 Switch.

#### **B4.1 UL Requirements for DC-powered units**

1. *Minimum 18AWG cable for connection to a Centralized DC power source.*
2. *Minimum 14AWG cable for connection to a earthing wiring.*
3. *Use only with Listed 10 A circuit breaker provided in building installation.*
4. *"Complies with FDA radiation performance standards, 21 CFR subchapter J." or equivalent.*
5. *Fastening torque of the lugs on the terminal block: 9 inch-pound max.*
6. *Centralized DC Power Source cable securement, use at least four cable ties to secure the cable to the rack at least 4 inches apart, with the first one located within 6 inches of the terminal block.*

#### **B5.0 OPERATION**

Operation of Magnum 6K32 Switches with the optional -48VDC, 24VDC and 125VDC power supply is identical to that of the standard AC-powered models.

#### **B6.0      ORDERING INFORMATION**

To order the optional -48VDC power supply factory installed, add a suffix of “-48VDC” after the product’s standard model # Example: **Magnum 6K32R-48VDC**.

Similarly to order the optional 24VDC or 125VDC industrial specific power supply factory installed, add a suffix of “24VDC” or “125VDC” after the product’s standard model #. Example: Magnum 6K32-24VDC, Magnum 6K32-125VDC.

#### **B7.0      TROUBLESHOOTING**

Please refer to Section 6.0 for troubleshooting

**APPENDIX C: Internal DC Dual-Source Power Option****C1.0 SPECIFICATIONS - FOR MAGNUM 6K32 FIBER SWITCH****Power Supply (Internal, -48VDC Dual-Source, model # Dual-Src-48V)**

DC Power Connector: First Source: "A+", "A-", 2nd Source "B-", "B+"

GND: Terminal for "earth" or ground wire connection to the hub chassis

Input: Two separate sources, each at 36 - 70 VDC

**Power Supply (Internal, 24VDC Dual-Source, model # Dual-Src-24V)**

DC Power Connector: First Source: "A+", "A-", 2nd Source "B-", "B+"

GND: Terminal for "earth" or ground wire connection to the hub chassis

Input: Two separate sources, each at 20 - 36 VDC

**Power Supply (Internal, 125VDC Dual-Source, model # Dual-Src-24V)**

DC Power Connector: First Source: "A+", "A-", 2nd Source "B-", "B+"

GND: Terminal for "earth" or ground wire connection to the hub chassis

Input: Two separate sources, each at 88 - 150 VDC

With the exception of the dual DC input power connections and the power supply, all specifications and configuration options for the Magnum 6K32 -48VDC, 24VDC and 125VDC models with this Dual-Source option are identical to those listed in the *Magnum 6K32 Fiber Switches Installation and User Guide*, including Appendix B "Internal DC Power Supply Option"

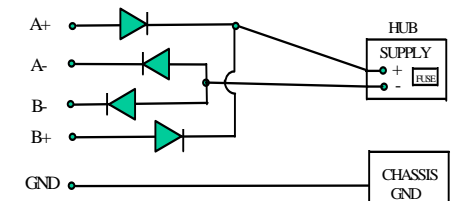
**C2.0 MAGNUM 6K32, with -48VDC, 24VDC and 125VDC Dual-Source option**

The 6K32-Switch models with the internal -48VDC, 24VDC and 125VDC Dual-Source power supply are designed for installations where a battery plant is the power source, and where two separate power sources are utilized in order to increase operational uptime and to simplify maintenance.

The functionality of the Magnum 6K32 Switch -48VDC, 24VDC and 125VDC Dual-Source Option units is identical to the standard AC-powered models. Refer to the main sections of this *Installation and User Guide* for a detailed description of the Magnum 6K32 Switches.

**C3.0 DUAL-SOURCE OPTION, THEORY OF OPERATION**

The Dual-Source DC power option is designed using diodes inside of the chassis on each DC power input line. A diode is placed in each of the four input lines (behind the four external power connection terminals) so that power from an external source can only flow into the unit. This allows the unit to operate whenever DC power is correctly applied to either or both of the two inputs



**C4.0 FEATURES AND BENEFITS OF THE DUAL-SOURCE DESIGN**

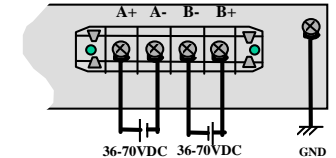
- The Switch unit can receive power from either input, "A" or "B". The hub will normally draw its power from the DC source with the highest voltage at a given time.
- The Switch unit will not allow power to flow from a higher voltage input to a lower voltage input, i.e. the two DC power sources are not mixed together by the hub.
- When one correct DC input is present, the Switch will receive power if the other DC input is absent, or even if it is connected with reverse polarity or shorted or grounded.
- Reverse polarity connections, if they should accidentally occur on either input, will not damage the Switch or power supply internally (nor will it blow the fuse in the internal power supply) because of the blocking action of the diodes. This is true even if one input connection is reversed while the Switch is operating from the other source.
- The Switch will not receive power (and will not work) when both inputs are simultaneously absent or are both incorrectly connected.

**C5.0 INSTALLATION**

This section describes the proper connection of the -48VDC, 24VDC and 125VDC dual source leads to the -48VDC, 24VDC 7 125VDC power terminal block on the Magnum 6Ks Switch (shown in Figure )

The -48VDC terminal block on the Magnum 6K32 Switch, as shown in Fig C5.0 is located on the right rear of the unit and

is equipped with five (5) screw-down lead posts. If it is the reverse model it is located on the left rear. The primary terminals are identified as positive (A+), negative (A-), and the secondary power terminals as negative (B-), positive(B+). The chassis "earth" or ground (GND) is a threaded post with a #6 nut. The Dual Source terminal block for the 24VDC, 24VDC and 125VDC are similar.



**Figure C5.0: -48VDC Dual-Source, wiring connections to the External Terminal Block on a Magnum 48VDC with Dual-Source option**

*Note: The GND should be hooked up first. The 6K32 unit has a floating ground, so the user may elect to Ground either + or - terminal to suit the customer's use.*

*Before connecting hot lines to the Terminal Block of -48VDC, 24VDC or 125VDC, always use a digital voltmeter to measure the output voltage of the power supply and determine the lead which is more "+ve potential". The more "+ve" voltage lead from 48V or -48V supply must be connected to the post labeled "+".*

The connection procedure is straightforward. Simply connect the DC leads to the Switch's power terminals, positive (+) and negative (-) screws. The use of Ground (GND) is optional; it connects to the Switch chassis. Ensure that each lead is securely tightened.

The 24VDC and 125VDC terminal block on Magnum 6K32's is similar to that described in the -48VDC information above.



**C5.1 UL Requirements**

The following must be adhered to in order to conform to UL requirements:

1. *Minimum 18 AWG cable for connection to a Centralized DC power source.*
2. *Minimum 14 AWG cable for connection to earthing wiring.*
3. *Use only with Listed 10 A circuit breaker provided in building installation.*
4. *“Complies with FDA radiation performance standards, 21 CFR subchapter J.” or equivalent.*
5. *Fastening torque of the lugs on the terminal block: 9 inch pound max.*
6. *Centralized DC Power Source cable securement, use at least four cable ties to secure the cable to the rack at least 4 inches apart with the first one located within 6 inches of the terminal block.*

**C6.0 ORDERING INFORMATION**

To order the optional Dual-Source -48VDC power supply factory installed, order “Dual-Src48V” as a separate line item following the product model.

Example: **Magnum 6K32R-48VDC**

**Dual-Src-48V** for the regular DS model with no ON-OFF switch  
or **Dual-Src48V-SWITCH** with the ON-OFF manual switch.

Similarly, order the “Dual –source 24VDC” or “Dual-source 125VDC” as a separate line item following the product model.

Example: **Magnum 6K32R-24VDC** or **Magnum 6K32R-125VDC**

**Dual-Src24V** for regular models with no ON-OFF switch

Or **Dual-Src125V-Switch** for models with the ON-OFF switch

**C7.0 OPERATION**

Operation of the Dual-Source Magnum 6Ks-48VDC, 24VDC and 125VDC Switch models are identical to that of the standard models.

## Free Manuals Download Website

<http://myh66.com>

<http://usermanuals.us>

<http://www.somanuals.com>

<http://www.4manuals.cc>

<http://www.manual-lib.com>

<http://www.404manual.com>

<http://www.luxmanual.com>

<http://aubethermostatmanual.com>

Golf course search by state

<http://golfingnear.com>

Email search by domain

<http://emailbydomain.com>

Auto manuals search

<http://auto.somanuals.com>

TV manuals search

<http://tv.somanuals.com>