



Magnum DS 880

10 / 100 Dual-Speed Stackable Hubs



Installation and User Guide

Magnum™ DS880 10/100 Dual-Speed Stackable Hubs

Installation and User Guide

Part #: 84-00058 Rev C (05/01)

Trademarks

Ethernet is a trademark of Xerox Corporation

NEBS is a trademark of Telcordia Technologies

UL is a registered trademark of Underwriters Laboratories

GarrettCom, **Magnum** and **Personal Switch** are trademarks and **Personal Hub** is a registered trademark of GarrettCom, Inc.

Important: The Magnum DS880 10/100 Dual Speed Stackable Hubs family contains no user serviceable parts. Attempted service by unauthorized personnel shall render all warranties null and void. If problems are experienced with Magnum DS880 10/100 Dual Speed Stackable Hubs products, consult Section 5, Troubleshooting, of this User Guide.

Copyright © 2001 GarrettCom, Inc. All rights reserved. No part of this publication may be reproduced without prior written permission from GarrettCom, Inc.

Printed in the United States of America.

Contacting GarrettCom, Inc

Please use the mailing address, phone and fax numbers and email address listed below:

GarrettCom, Inc.
47823 Westinghouse Dr.
Fremont, CA 9453-7437
Phone (510) 438-9071
Fax (510) 438-9072
Website: <http://www.GarrettCom.com>

email support@garrettcom.com

Federal Communications Commission**Radio Frequency Interference Statement**

This equipment generates, uses and can radiate frequency energy and if not installed and used properly, that is in strict accordance with the manufacturer's instructions, may cause interference to radio communication. It has been tested and found to comply with the limits for a Class A computing device in accordance with the specifications in Subpart J of Part 15 of FCC rules, which are designed to provide reasonable protection against such interference when operated in a commercial environment. Operation of this equipment in a residential area is likely to cause interference, in which case the user at his own expense will be required to take whatever measures may be required to correct the interference.

The Magnum Line

ETHERNET CONNECTIVITY PRODUCTS

"DESIGNED AND MANUFACTURED IN THE USA"

OVERVIEW

GarrettCom, Inc. offers the premium-quality Magnum™ line of Ethernet LAN connectivity products with industry-standard functionality and built-in fiber configurability. Magnum products are designed for use in demanding Carrier Class, Industrial Grade and OEM applications where reliability is a primary consideration.

4K-Series Switches, 100 & 10Mbps, copper ports with optional fiber port, with auto-negotiating full switching performance

Quad-Series Fiber Switches, 100 & 10Mbps, fiber and copper ports, mixed-speed and mixed-media types, full switching performance

“Outdoor” Ethernet Switch, for temperature uncontrolled locations

6 10/100 and 2 100Mb fiber ports, can be connected in strings

Mixed-Media Fiber Hub, 16-port Stackable, 10/100 auto-sensing

Dual Speed 8-port and 16-port Stackables, 10/100 auto-sensing

Stackable Hubs, SNMP Optional

10Mb series and 100Mb series, both w/ optional port modules

Personal Switches, 10/100Mb

8 port dual speed, Auto-negotiable with fiber option

Personal Hubs, 100Mb or 10/100Mb

8-port, with two switched ports (1 fiber built in)

Personal Hubs, 10Mb series

8-port + AUI, stackable to 5 high, + optional BNC or fiber port

8 or 9-port and 4 or 5-Port Personal Hubs, w/ man. up-link sw.

Media Converters, 10Mb and 100Mb series

All media combinations, incl. fiber ST, SC, mm., single mode

The “X-line” of configurable Mixed Media products:

Stackable Concentrators, SNMP optional, 13-Ports

Mini-Concentrators, 7 Ports, Repeaters, 2-Ports

Repeater Port Modules (RPMs), 6 types for Ethernet media

Bridge Port Modules (BPMs), 4 types, for segment isolation

Fan-Outs, 10Mb series

2, 4 and 8 Port Models

Transceivers, 10Mb and 100Mb series 10Mb Mini-Transceivers

and Coax Models, All Types - Apr, 01

| TABLE OF CONTENTS | PAGE |
|---|------|
| 1.0 SPECIFICATIONS | 1 |
| 1.1 Technical Specifications | 1 |
| 1.2 Ordering Information | 3 |
| 2.0 INTRODUCTION | 4 |
| 2.1 Inspecting the Package and Product | 4 |
| 2.2 Product Description | 5 |
| 2.2.1 Magnum DS880 Chassis | 7 |
| 2.2.2 10 / 100 Speed Auto-sensing | 7 |
| 2.3 Stacking Magnum DS880's | 8 |
| 2.4 Bridge Module between the 10Mb and 100Mb Domains | 9 |
| 2.5 Up-link Switch on Port # 8 for Cascading | 9 |
| 2.6 Features and Benefits | 10 |
| 2.7 Applications | 11 |
| 3.0 INSTALLATION | 13 |
| 3.1 Locating Magnum DS880 Dual-Speed Hubs | 13 |
| 3.1.1 Table-Top or Shelf Mounting | 13 |
| 3.1.2 Wall (or Vertical Surface) Mounting | 13 |
| 3.2 Connecting Ethernet Media | 14 |
| 3.2.1 Connecting Twisted Pair (CAT3, CAT5) | 14 |
| 3.2.2 Collision Domain Diameter, Cable Distances and PDV Calculations | 14 |
| 3.2.3 Connecting to NICs which support Auto-Negotiation | 17 |
| 3.3 Powering the Magnum DS880 | 18 |
| 4.0 OPERATION | 18 |
| 4.1 Dual-Speed Functionality | 18 |
| 4.1.1 Software Transparency | 20 |
| 4.2 Port Speed settings for 10,100 and 10/100Mbps Mode only | 20 |
| 4.3 Auto-negotiation and speed-sensing | 21 |
| 4.4 LEDs | 21 |
| 4.5 Up-link Switch | 21 |
| 5.0 TROUBLESHOOTING | 22 |
| 5.1 Before Calling for Assistance | 22 |
| 5.2 When Calling for Assistance | 23 |
| 5.3 Return Material Authorization (RMA) Procedure | 23 |
| 5.4 Shipping and Packaging Information | 24 |
| APPENDIX A: WARRANTY INFORMATION | 24 |
| APPENDIX B: OPTIONAL 48VDC POWER SUPPLY, ADDENDUM | 25 |

Revisions

Rev C 05/01 : Change the company name to GarrettCom, Inc. (Formerly it was Garrett Communications). There are no changes to the content of the material at this time

Rev B 02/99 : Added optional 48vdc power supply addendum; Port Speed settings for 10,100 and 10/100Mbps Mode only; Connecting to NICs which support Auto-Negotiation information; and Collision Domain Diameter, Cable Distances and PDV calculations.

Rev A 10/97 : This revision is the initial release of the DS880 Dual Speed Stackable Hubs user manual.

1.0 SPECIFICATIONS

1.1 Technical Specifications

100 or 10 Mb/s per port, auto-sensing for speed. DS880 hubs support two traffic domains, one at 100Mb/s and one at 10Mb/s, have eight RJ-45 ports, and are stackable up to 3 units high operating as one repeater.

Performance

When a port is operating at 100Mb/s:

Data Rate: 100 Mb/s

PDV (Path Delay Value) : 80BT, exceeds Class II

When a port is operating at 10Mb/s:

Data Rate: 10 Mb/s

Partitioning: Enforced after 63 consecutive collisions

Auto-reconnect: Occurs after one packet of error-free reception

Network Standards

100Mb: Ethernet IEEE 802.3u , 100BASE-TX

10Mb: Ethernet IEEE 802.3, 10BASE-T

Auto-sensing for speed: IEEE 802.3u

Packet-Processing Between Domains (internal 10/100 switch or bridge)

Filtering and Forwarding Rate from 100Mb ports: 148,800 pps max

Filtering and Forwarding Rate from 10Mb ports: 14,880 pps max.

Processing type : Store and Forward

Auto-learning : 8K address table, shared for both traffic domains

Packet buffers : 2MB,dynamically allocated & shared on both domains

Latency (not including packet time) : 100 to 10Mb : 5 μ s

10 to 100Mb : 5 μ s

CPU Type : State Machine

Maximum Ethernet Segment (or Domain) Lengths

10BASE-T (Unshielded twisted pair) - 100 m (328 ft)

100BASE-TX (CAT 5 UTP) - 100 m (328 ft)

Operating Environment

Ambient Temperature: 32°F to 122°F (0°C to 50°C)

Storage Temperature: -20°C to 60°C

Ambient Relative Humidity: 10% to 95% (non-condensing)

Power Supply (Internal)

AC Power connector : IEC-type, male recessed, rear of chassis

Power Input Voltage : 90 to 260 VAC (auto ranging)

Power Input Frequency : 47-63 Hz

Power Consumption : 20 watts max.

(1.1 Technical Specifications, continued)**48VDC Power Supply (Optional)**

Power Input Voltage : 36 to 72 VDC (auto ranging)

Terminal Block in rear: “-, GND, +”

Power Consumption: 20 watts max.

Network Cable Connectors - for the eight RJ-45 shielded female ports per hub

100Mb: Category 5 UTP/STP

10Mb: Category 3, 4, 5 UTP (Note: speed-sensing does not sense cable type)

Stacking Cable - stacking may be up to four DS880 hubs, or 32 ports

A stacking cable with 50-pin “SCSI” male connectors, shielded, 9 inches (23 cm) long, is included with each Magnum DS880-A Dual-Speed add-on unit.

Switch, Manual

UP-LINK : MDI-X thumb-operated slide switch, converts RJ-45 port #8 from a regular (=position) user segment port to a crossover (X position) up-link port for On/Off connection to a central hub or another cascaded hub. The up-link port #8 is auto-sensing for speed, and the up-link works the same at 10Mb or 100Mb.

Packaging

Enclosure: High strength metal. Metal mounting brackets included.

Suitable for wiring closet shelf, wall or desktop mounting.

Dimensions: 9.75 in D x 8.5 in. W x 1.4 in. H (25cm x 22cm x 3.5cm)

Weight: 2.5 lb. (1.15 Kg)

Cooling method: Fan cooled, internal @ 9 cfm

LED Indicators

PWR : Steady On when power applied

BR : Bridge Module Indicator, On when 10/100 bridge module is installed (Model DS880-B), Off when no bridge module is inside (DS880-A)

COL : Collision LEDs, one each for 100Mb and 10Mb speed domains

ACT : Common packet activity indicator, one for each traffic domain

100 (per port): Steady On when speed is 100Mbps , Off when speed is 10Mb, flashing when auto-negotiating or when not connected (no LINK)

LK (per port): Steady On when twisted-pair link is operational

RX (per port): Activity, flashing when port is receiving data

Agency Approvals

UL Listed (UL 1950), cUL, CE

Emissions: meets FCC Part 15, Class A

Optional: NEBS L3 Certified

Warranty

Three years, return to factory

Made in USA

1.2 Ordering Information

Magnum DS880 Dual-Speed Stackable Hubs

Magnum DS880-A: Dual-Speed 10/100 Stackable Hub with eight RJ-45 ports, each auto-sensing for 100Mb or 10Mb operation. Stackable up to three units high, with all ports in one stack operating as two separate traffic domains, one domain at 100Mb/s and one domain at 10Mb/s. Includes stacking cable, internal auto-ranging power-supply, cooling fan, and metal brackets for shelf or wall mounting.

Magnum DS880-B: Same as Magnum DS880-A but includes an internal switch module that bridges the two traffic domains, filtering and selectively forwarding packets between the 100Mb and the 10Mb domains. Stacks up to three DS880-A units. One DS880-B unit per stack supports all ports at 100Mb or 10Mb communicating with each other. The internal switch has 2Mb dynamic store-and-forward packet buffers and 8K node addresses.

GarrettCom reserves the right to change specifications, performance characteristics and/or model offerings without notice.

2.0 INTRODUCTION

2.1 Inspecting the Package and Product

Examine the shipping container for obvious damage prior to installing this product; notify the carrier of any damage which you believe occurred during shipment or delivery. Inspect the contents of this package for any signs of damage and ensure that the items listed below are included.

This package should contain:

- 1 Magnum DS880-A or DS880-B Dual-Speed Hub Unit
- 1 AC Power Cord (U.S. and other 115 vac locations only)
- 1 Stacking Cable, Model DS880-A add-on (no bridge inside) units only
- 1 Set of metal clips and screws for wall-mounting
- 1 Installation and User Guide
- 1 Product Registration Card

Remove the Magnum DS880 Dual-Speed Hub from the shipping container. Be sure to keep the shipping container should you need to ship the unit at a later date. To validate the product warranty please complete and return the enclosed Product Registration Card to GarrettCom, Inc. as soon as possible.

In the event there are items missing or damaged contact your supplier. If you need to return the unit use the original shipping container. Refer to Chapter 5, Troubleshooting, for specific return procedures.

2.2 Product Description - General

Magnum DS880 Dual-Speed hubs have eight RJ-45 ports, each 10/100Mb auto-sensing. Each port can independently identify (via IEEE 802.3u auto-sensing) and accept either 100Mb or 10Mb Ethernet signals, adapting to match the best speed of the connected device. There are two internal traffic domains in Magnum DS880 hubs, one for the 100Mb traffic and one for the 10Mb traffic. The 100Mb users share the 100Mb domain's bandwidth and the 10Mb users share the 10Mb domain's bandwidth.

Any DS880 port can connect into either the 100 or the 10Mb traffic domain, and can also change from one traffic domain to the other at any time without affecting the speed of other ports. The automatic per-port speed-sensing is continuous, allowing the connected devices to change speed at any time without impairing the operation of the other ports and connected devices.

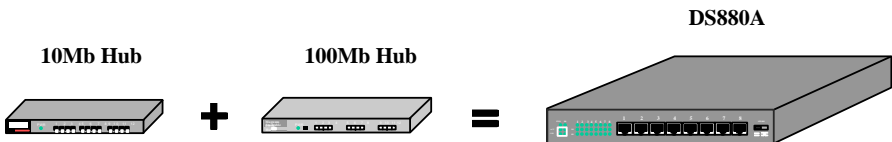

Figure 2.2.1 : Magnum DS880 is functionally both a 10Mb and a 100Mb hub in one

As Magnum DS880 Dual-Speed units are stacked, the two shared traffic domains automatically expand to support all of the ports in the stack. Any combination of 10Mb and 100Mb ports, up to the maximum of 32 ports (4 units) in one stack, can be in use at any time.

One DS880 Model, the Magnum DS880-B, includes an internal bridge or switch module which interconnects the 10 Mb and the 100Mb traffic domains. This enables all users on a DS880-B hub or a DS880 stack, whether 100Mb or 10Mb, to talk to each other. The internal switch of the DS880-B filters and selectively forwards packets between the 10Mb and the 100Mb domains, maintaining peak performance in each domain unaffected by local traffic in the other domain. The internal bridge is self-learning, with large address table capacity for up to 8K node addresses. As networked nodes are added or removed or move from one speed domain to the other, the DS880's internal switch automatically keeps track.

2.2 Product Description - General (continued)

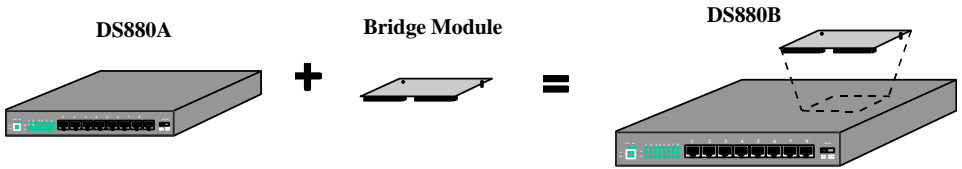

Figure 2.2.2 : DS880B is a DS880A with a bridge module built-in for 10 to 100 bridging

Only one DS880-B unit is needed to support a stack. Additional 8-port units of the DS880-A “add-on” hubs . . . units that do not have the bridge module inside, and which cost less accordingly . . . can be added to the stack, up to the 4-unit stack maximum. In a stack, the DS880-B unit (illustrated below as the bottom unit) can be in any stack position.

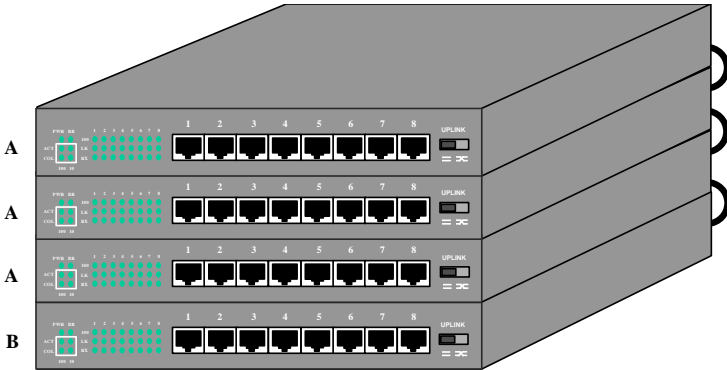

Figure 2.2.3 : Stack of DS880's, 3 @ DS880A's and 1 @ DS880-B

DS880-A units can also be used without a DS880-B, whereupon they will function as dual-speed stackable hubs. This could be desired if there is an external non-auto-sensing switch (such as the Magnum 300ES Two-Port Switch) available to interconnect the two speed domains, or if only 100Mb devices are connected and the 10Mb domain is unused (or vice-versa), or if dual-speed operation with two unconnected and uncoordinated domains is needed for the application.

Each DS880 has its own internal power supply, and is easily added to an existing 10 or 100Mb network. DS880s are suitable for wiring closet shelf, table-top or vertical mounting.

2.2.1 Magnum DS880 Chassis

The Magnum DS880 chassis houses one main PC board, a bridge module daughter-board in the Model DS880-B, and an internal power supply unit. The front side of the chassis has eight RJ-45 twisted-pair ports and one cascading (UP-LINK) switch for Port 8 on the right.

LEDs to indicate operating status are on the left front side. There are power (PWR) and bridge-inside (BR)

indicators for the unit.

There are activity (ACT)

and collision (COL)

indicators for each of the

10Mb and 100Mb domains,

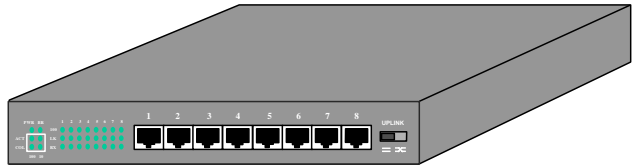

Magnum DS880 Dual-Speed Hub

set unto a “square” arrangement, for visual indication of the operating status of each domain.

And there are link (LK), receive (RX) and speed (100) indicators for each port. (See Section 1.1 “Specifications” for a technical description of the LEDs). The unit has a cooling fan on the bottom left corner which sends warm air out away from the unit to the rear. Stacking cables connect in the rear (see Section 2.3 for stacking information).

The AC power cord connector, a universal recessed-male IEC type, is in the left rear of the chassis. The internal power supply is auto-ranging for any AC power input of 115 - 230 vac, 50 - 60 Hz. (An internal DC power supply is optional).

2.2.2 10 / 100 Speed Auto-sensing

All eight RJ-45 twisted pair ports support auto-sensing for speed, independent of the other ports. Speed-sensing is performed by the DS880’s electronics in accordance with the standards of the IEEE 802.3u auto-negotiation standard. If the connected device or node indicates that it is capable of 100Mb speed, then operation on that port will be at 100Mb/s. If the connected device does not positively indicate that it is capable of 100Mb speed, then the operation on that DS880 port will be at 10Mb/s. Of course, the hubs’ auto-negotiation technique is only for 10 / 100 speed, and does not provide for any full-duplex operation.

When a port is connected and LINK is present, the speed on that port that has been sensed by the DS880 hub will be indicated by the ‘100’ LED for that port. The ‘100’ LED is ON when 100Mb speed is sensed, and is OFF when 10Mb speed is in use. When a port is not connected, the ‘100’ LED corresponding to that port will be blinking to indicate that it is trying to auto-negotiate. (See section 4.3 for operation of the LED’s).

2.3 Stacking Magnum DS880s

Up to four Magnum DS880s can be stacked to operate as one 10/100 dual-speed repeater with up to 32 dual-speed ports. Normally, one Magnum DS880-B hub per stack is needed to provide a

switched interconnection between the two separate 100Mb and 10Mb traffic domains in the stack.

Additional stacked units are normally Model DS880-A “add-on” units, which cost less.

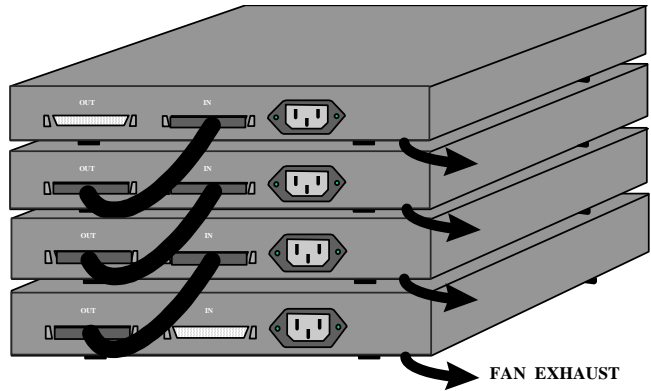

Figure 2.3 : Magnum DS880's stacked. Cables connect between “Out” and “In” Ports

The DS880-B models with the bridge module inside look the same as the DS880-A units (no bridge inside) from the outside. The “BR” LED on the front will light up when power is applied to indicate that a DS880 is a -B (bridge inside) model. (The “BR” LED will be off if the unit is a Model DS880-A). The DS880-B models cannot be stacked together, as their internal bridges would not be able to function properly when more than one is present. (Note that two DS880-B units may be cascaded to operate together, however). Use DS880-B models un-stacked, or with only 1 Model DS880-B in a DS880 stack. See Section 2.7, Example 3.

When stacking DS880's, please make sure to use only the shielded 9-inch long stacking cable provided with each DS880-A unit. The cable length is designed to provide proper operation of up to four DS880 units in a stack, and longer cables or unshielded cables are not permitted as they will not operate properly at 100Mb speeds.

The 9-inch length is enough to provide for side-by-side stacking. This can be convenient when locating the DS880s in a rack, for example, as two DS880s will fit side-by-side on a tray in a standard 19" rack space.

When connecting DS880s in a stack, use the stacking cable to connect the “Out” stacking port from one DS880 unit to the “In” stacking port of the other. Push in the cable connectors until they snap in firmly. Also, leave space in the left-rear area for the exhaust of the internal cooling fan in each DS880 unit. See Figure 2.3 above.

2.4 Bridge Module between the 10Mb and 100Mb Domains

Figure 2.4 : Internal view of DS880-B with bridge module installed

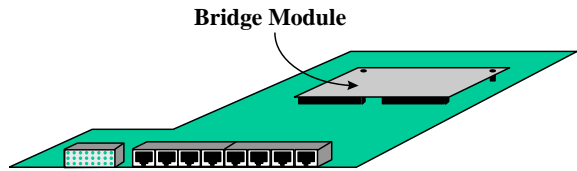

Magnum DS880-B's contain a factory-installed bridge module to interconnect the two traffic domains, filtering and selectively forwarding packets to allow only necessary packets to cross between the domains. This enables all of the users and nodes connected into either domain, whether 100Mb or 10Mb, to talk to each other, and it keeps local traffic on one domain from consuming any of the bandwidth of the other domain.

The bridge operates in the store-and-forward mode, which filters out bad packets and maintains optimum performance in both domains. Packet forwarding delay is only $5\mu\text{s}$ (plus packet time), much less than traditional store-and-forward bridge products, enabling the DS880s to maintain high network performance. The bridge has 8K node address capacity, suitable for use in large networks. Addresses are self-learning so that filtering / forwarding of 10Mb and of 100Mb packets is maintained correctly even when users move their connection, or change speed, or power down.

The DS880-B's bridge module is implemented as a daughter board. DS880 units have an LED on the front labeled 'BR' that will be 'ON' when the module is installed internally. Power any DS880 unit on and if the BR LED is ON, it is a Magnum DS880-B unit.

NOTE : Only one Magnum DS880-B (with a bridge module built-in) is allowed per repeater stack. Thus, if the DS880s in a stack have more than one BR (bridge) LED 'ON', it is an illegal configuration.

2.5 Up-link Switch on Port 8 for Cascading

The unit has an up-link switch for Port # 8, located on the right-front side of the hub. It enables the port's cable to either connect to a user station (= position) or to be cascaded to another hub (X position). (See Section 4.4 for more details about up-link). Like all DS880 ports, Port # 8 is a dual-speed port which will sense the speed of the connected device. The up-link switch operates the same, whether Port # 8 is connected to either 100Mb or 10Mb devices.

When the up-link port is used to cascade two DS880 hubs or stacks together, the auto-sensing feature will cause the connecting link to operate at 100Mb speed.

2.6 Features and Benefits

■ Supports 10 or 100Mb network connections on each of eight RJ-45 ports

Magnum DS880 Dual-Speed 10 / 100 hubs combine two logical hubs . . . one at 10Mb and one at 100Mb . . . in one physical box supporting two traffic domains. Each port can operate at either 10 or 100Mb, independently of the other ports.

■ Auto-sensing for speed, 10 or 100Mb on each port

All ports support 10/100 auto-negotiation for speed, operating separately on each port. Any mix of 10Mb and 100Mb users can be connected to the ports. Speed-sensing is continuous. Individual ports can change to 100Mb or 10Mb speed at any time, adapting automatically to any changes in the connected device's speed. Speed-sensing complies with IEEE 802.3u, providing interoperability with other products.

■ An internal switch connects the 10 and 100Mb domains on Model DS880-B

Model DS880-B has an internal switch for filtering / forwarding traffic between the 10 and 100Mb domains, allowing all connected devices to talk to each other. High performance switching provides full bandwidth in each domain, unaffected by local traffic on the other domain. One DS880-B per stack supports switching for all ports.

■ Stackable for flexible expansion

Magnum DS880s can be stacked up to four units high for 32 ports, each 10 / 100 dual speed. As additional units are added in a stack, the 10 and 100Mb traffic domains are expanded automatically to support the new ports at either 10 or 100Mb speed.

■ Installation is "Plug and Play", Operation is Transparent to Software

The Magnum DS880-B operates as a hardware switch, only forwarding those packets from each domain that are needed on the other domain. Internal address tables are self-learning, enabling users to change port connections or 10 / 100 domains without affecting operations. The switch in the DS880-B will not affect any standard software applications or SNMP network management platforms.

■ Small Enclosure Enables Use in Offices and Labs

The compact packaging of Magnum DS880s allows them to be installed in offices and labs, or virtually any location within reach of a standard AC wall outlet. They come in a durable metal enclosure for table-top or wall-mounting. They have an internal auto-ranging power supply for use worldwide. (Models with a 48vdc internal power supply are optionally available).

2.7 Applications

Example 1 : A Magnum DS880-B serves a small office with mixed speed requirements. Some users operate at 100Mb, and some users and utility devices (such as print servers) run at 10Mb. All share the same hub, and talk to each other via the bridge module inside. Any node can change speed at any time without affecting network operation or impacting other users.

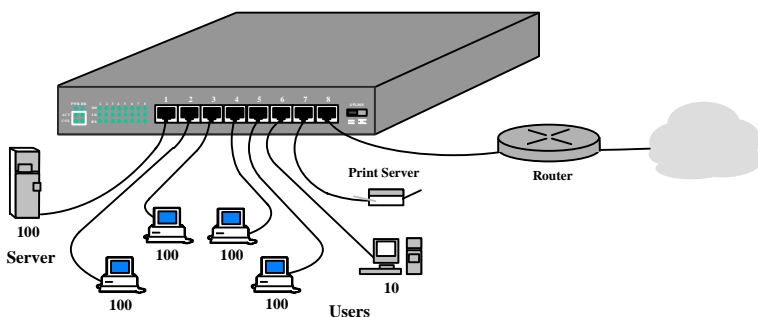
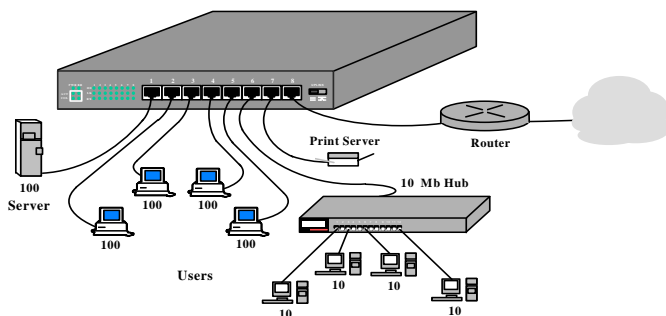

Figure 2.7.1 : DS880-B connects combinations of 10Mb and 100Mb network devices

Example 2 : Where there are existing 10Mb hubs and users, they can easily be cascaded into any port of the DS880-B. This allows simple plug-and-play addition of 100Mb ports to an existing 10Mb network without having to change it. Nodes that are capable of 100Mb speed can be moved to any DS880 dual-speed port, and will automatically operate at the higher speed. The dual-speed ports on the DS880-B can be used for adding 100Mb users or for accommodating existing high performance users. The 100Mb traffic does not use the bandwidth of the 10Mb domain, so overall performance of the network is improved.

Figure 2.7.2 :
DS880-B adds a new
100Mb domain to
existing 10Mb
network



Example 3 :

For additional expansion, DS880s can be expanded by stacking DS880-A “add-on” units. The additional stacked ports are all auto-sensing dual-speed, and can be used at either 10Mb or 100Mb on a per-port basis.

The stacking cables connect the DS880 units and carry the signals for both the 100Mb and the 10Mb domains. In a stack, all 10Mb ports are together in a 10Mb traffic domain while all 100Mb ports are similarly together on a separate 100Mb traffic domain. When one DS880-B unit with a bridge inside is present in a stack, its bridge will support all of the ports in the stack and enable network traffic to move between the two stacked domains.

A Magnum DS880 stack operates as one dual-speed repeater. A dual-speed repeater is both a 10Mb hub and a 100Mb hub at the same time. This means that the 10Mb traffic domain obeys all of the rules of 10Mb shared Ethernet networks (hop counts, cable types, cable distances, etc.) and can be treated as one 10Mb repeater accordingly. Separately, the 100Mb traffic domain obeys all of the rules of 100Mb Fast Ethernet shared networks (hop counts, PDVs, cable types, cable distances, etc.) and can be treated as one 100Mb repeater. Both traffic domains function within the same physical DS880 hub or stack of hubs.

Figure 2.7.3 :
Stack of Magnum
DS880's operate as
one 10/100 dual-speed
repeater

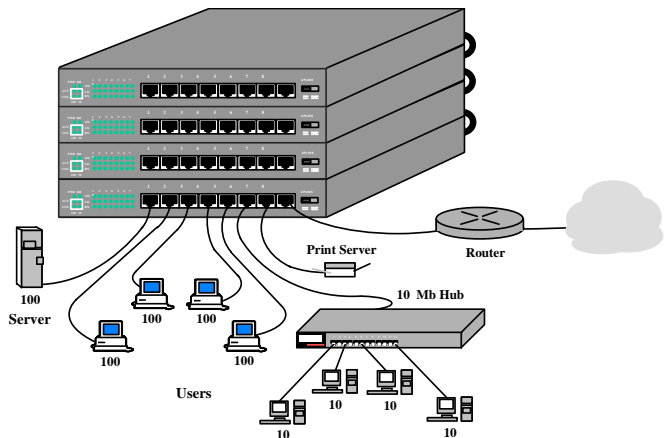

When expanding an Ethernet or Fast Ethernet installation, the Magnum DS880 Hubs are ideally suited for connecting servers and stations that have (or may have in the future !) mixed speeds. Each traffic domain or segment has its own local traffic with the Magnum DS880-B performing bridge-isolation of one domain from the other, filtering and selectively forwarding 10Mb and 100Mb packets between the two domains. This keeps the traffic between the domains to a minimum and provides peak performance on both domains.

3.0 Magnum DS880 Installation

Before installing the equipment, it is necessary to take the following precautions:

- 1.) If the equipment is mounted in an enclosed or multiple rack assembly, the environmental temperature around the equipment must be less than or equal to 50°C.
- 2.) If the equipment is mounted in an enclosed or multiple rack assembly, adequate air flow must be maintained for proper and safe operation.
- 3.) If the equipment is mounted in an enclosed or multiple rack system placement of the equipment must not overload or load unevenly the rack system.
- 4.) If the equipment is mounted in an enclosed or multiple rack assembly, verify the equipment's power requirements to prevent overloading of the building/s electrical circuits.
- 5.) If the equipment is mounted in an enclosed or multiple rack assembly verify that the equipment has a reliable and uncompromised earthing path.
- 6.) If the intra-building wiring (cabling) is involved with this product (NEBS), then it is recommended to have shielded cable and the shield is grounded at both ends.

This chapter provides instructions for installing the Magnum DS880 hubs

3.1 Locating Magnum DS880 Dual-Speed Hubs

The location of a Magnum DS880 Dual-Speed Hub is dependent on the physical layout of the network. Typically the hub is placed where combinations of 10Mb and 100Mb network devices need to be connected to communicate with each other. The compact size of the unit allows it to be conveniently placed in an office or lab area, and it can also be either shelf or wall-mounted (see instructions in 3.1.2 below). Wall-mounting brackets are included, usable for single units (but not for stacks). The width of two DS880 units will fit in a 19" rack when they are side-by-side.

Locate an AC receptacle that is within six feet (2 meters) of the intended Magnum DS880 site. The rugged metal case of the Magnum DS880 will normally protect it from accidental damage in a lab or workplace setting. Maintain an open view of the front to visually monitor the status LEDs. Keep an open area around the unit so that cooling can occur from the small fan in the bottom-rear while the unit is in operation.

3.1.1 Table-Top or Shelf Mounting

The Magnum DS880 Dual-Speed Hub can be easily mounted on a table-top or any suitable horizontal surface, and has four rubber feet to provide stability without scratching finished surfaces. When stacked, the rubber feet also provide separation between units for the exhaust of the rear cooling fan.

3.1.2 Wall (or Vertical Surface) Mounting

Each Magnum DS880 Dual-Speed Hub is shipped with two metal mounting brackets (and screws) to allow the unit to be mounted in nearly any desired orientation or position. The brackets are attached to the metal hub case using one of the metal screws for each bracket and attaching to the Magnum DS880 through the round hole of the bracket. A user-supplied screw attaches the bracket to the mounting surface. It is recommended that the brackets be attached to two opposite corners of the unit. When properly attached, the brackets will extend slightly below the base of the unit to allow clearance for the rubber feet and the cooling fan exhaust.

3.2 Connecting Ethernet Media

The Magnum DS880 Dual-Speed Stackable Hubs can be connected to the following two media types: 100BASE-TX and 10BASE-T. CAT 5 cables should be used when making 100BASE-TX connections. When the ports are used as 10BASE-T ports, CAT 3 may be used. In either case, the maximum distance for unshielded twisted pair cabling is 100 meters (328 ft).

| <u>Media</u> | <u>IEEE Standard</u> | <u>Connector</u> |
|----------------------|----------------------|------------------|
| Twisted Pair (CAT 3) | 10BASE-T | RJ-45 |
| Twisted Pair (CAT 5) | 100BASE-TX | RJ-45 |

NOTE : It is recommended that high quality CAT. 5 cables (which work for both 10Mb and 100Mb) be used whenever possible in order to provide flexibility in a mixed-speed network, since dual-speed ports are auto-sensing for either 10 and 100Mb/s.

3.2.1 Connecting Twisted Pair (RJ-45, CAT 3 or CAT 5, Unshielded or Shielded)

The following procedure describes how to connect a 10BASE-T or 100BASE-TX twisted pair segment to the RJ-45 port. The procedure is the same for both unshielded and shielded twisted pair cables.

1. Using standard twisted pair media, insert either end of the cable with an RJ-45 plug into the RJ-45 connector of the port. Note that, even though the connector is shielded, either unshielded or shielded cables and wiring may be used.
2. Connect the other end of the cable to the corresponding device.
3. Use the LINK LED to ensure proper connectivity by noting that the LED will be illuminated when the unit is powered and proper connection is established. For Port # 8, if the LINK LED is not illuminated, change the setting of the up-link switch. If this does not help, ensure that the cable is connected properly and that the device on the other end is powered and is not defective.

3.2.2 100Mbps Collision Domain Diameter, Cable Distances and PDV Calculations

The 100Mbps Collision Domain Diameter is the length of the longest path between any two devices in a single collision domain. A collision domain is defined as a cluster of network devices which are connected by means of a repeater or repeaters such that no bridging devices are present between any two devices in the cluster. In order to install an IEEE 802.3u compliant Fast Ethernet network, the collision domain . . . regardless of the actual network topology . . . must be less than 512 BT (Bit Times). Bit Times are related to media type as shown in Table 3.2.2a.

Table 3.2.2a: Worst case round-trip delay for Fast Ethernet media*

| Media Type | Round-trip delay in Bit Time per Meter (BT/m) |
|---------------------|---|
| Fiber Optic | 1.000 |
| Shielded TP cable | 1.112 |
| Category 5 Cable | 1.112 |
| Category 3, 4 Cable | 1.140 |

*Worst case delays taken from IEEE Std 802.3u-1995, actual delays may be less for a particular cable. Contact your cable supplier for exact cable specifications.

Each Fast Ethernet device component also has an associated BT delay which depends on the physical signaling system employed. Table 3.2.2b shows each Fast Ethernet device component and the associated BT delay. A “DTE” is an end node, such as a user station. Note that there is only one DTE pair associated with any device-to-device path.

Table 3.2.2b: Worst case round-trip delay for Fast Ethernet device components*

| Component | Round-trip delay in Bit Times (BT) |
|---|------------------------------------|
| 2 TX DTEs | 100 |
| 2 FX DTEs | 100 |
| 1 FX and 1 TX DTE | 100 |
| 1 T4 and 1 TX or FX DTE | 127 |
| Class I Repeater | 140 |
| Class II Repeater with any combination of TX and FX ports | 92 ** |

****Note, the delay is only 80 Bit Times for the DS880, front-port-to-front-port.**

*Worst case delays taken from IEEE Std 802.3u -1995.

To determine whether a prospective network topology adheres to the collision domain diameter specification, the following formula should be applied to the worst case path through the network. The worst case path is the path between the two Fast Ethernet devices (DTEs) which have the longest round-trip time.

$$\text{PDV} = (\text{sum of cabling delays}) + (\text{sum of repeater delays}) + (\text{DTE pair delay}) + (\text{safety margin})$$

PDV is the Path Delay Value of the worst case path. For the network to adhere to IEEE standard, this value must be less than 512 BT. The safety margin is specified in BT and may be a value between 0 and 5. This margin can be used to accommodate unexpected delays such as extra long patch cable. A safety margin of about 2 to 4 BT is recommended.

A typical example of a PDV calculation is shown below, and is illustrated in Figure 3.2.2a. Here, an integrator wishes to cascade the 100Mbps collision domains of two Magnum DS880 Hubs (each having a PDV of 80BT) for use with standard 100m Category 5 user cable segments (i.e. from computer to hub) and needs to know how long the inter-repeater Category 5 cable segment, used to cascade the hubs, can be. The variable "X" represents the unknown maximum cascade cable delay.

$$\begin{aligned} \text{PDV} &= X + ((111 + 111) + (80 + 80) + (100) + 2) \text{ BT} < 512 \text{ BT} \\ 512 &> (X + 486) \text{ BT} \\ X &< (512 - 486) \text{ BT}, X < 28 \text{ BT} \\ \text{Twisted Pair cable length, TL} &< (28 \text{ BT}) / (1.112 \text{ m/BT}) \\ \text{TL} &< 25 \text{ meters} \\ \Rightarrow & \text{ 25 m maximum total length for Category 5 inter-repeater segment,} \end{aligned}$$

where 111 is the BT delay for 100m of Category 5 cable (1.112 BT/m* 100m), 80 is the BT delay for each Magnum DS880, 100 is the BT delay for the TX DTE pair, and a safety margin of 2 was used.

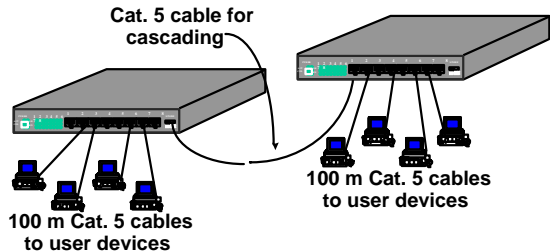

Figure 3.2.2a: Two cascaded Magnum DS880 hubs

The resulting value tells us that a Category 5 cable with a length of up to 30 meters may be used to cascade the Magnum DS880s. Note that this inter-repeater cable length may be increased by shortening the lengths of the 100m hub-to-user cable segments.

It is also possible to cascade a group of up to nine Magnum DS880s (serving up to 56 users with full-length 75m cables to each) by using short inter-repeater cable segments. The following is an example of how to calculate the maximum allowable cascade cable segment length. An illustration of this example is shown in Figure 3.2.2b, where the hub-to-user cable

lengths are up to 100 meters for Cat 5 twisted pair. The variable “X”, the maximum hub-to-hub cable delay, is calculated as follows:

$$PDV = X + ((100) + (80 + 80 + 80) + (83 + 83) + 2) \text{ BT} < 512 \text{ BT}$$

$$512 > (X + 508) \text{ BT}, \quad X < 4 \text{ BT}$$

$$\text{Twisted pair user cable length, TL} < (4 \text{ BT}) / (1.112 \text{ m/BT})$$

$$\text{TL} < 3.6 \text{ meters for two hub-to-hub cascading cables}$$

⇒ 2 meters (6 ft.) length max. for each of the cascade segments,

In the above example, 80 is the BT delay for 75m of Category 5 cable (1.112 BT/m), 80 is the bit time delay for each Magnum DS880 front-to-front ports, 100 is the BT delay for the TX DTE pair in the user stations, and 2 BT is the safety margin applied.

Figure 3.2.2b: Multiple cascaded Magnum DS880 hubs

Note that the cascading of multiple Magnum DS880 hubs is a capability beyond what industry standards normally permit, and is different from what competitive Class II hub products normally allow. This additional cascading level and cable length is

due to the relatively shorter bit time (80 BT actually measured, for front-port-to-port) delay of the 100Mbps domain of the Magnum DS880 vs. the industry standard delay of 92 BT for Class II repeaters. The installation flexibility and network growth potential is accordingly better with Magnum DS880s than with hubs that merely meet the standard.

Table 3.2.2c shows maximum cable lengths for common network configurations using industry standard repeater PDV numbers. Calculations such as above should be performed using measured PDV data supplied by the equipment manufacturer in important installations.

Table 3.2.2c: Maximum segment lengths for common network configurations

| Number of Hubs | Repeater Hop Count | Max. User Segment Lengths (m) | Max. Inter-Repeater (Cascade) Length (m) | Notes |
|----------------|--------------------|-------------------------------|--|--------------|
| 1 | 1 | 100.0 | n.a. | All ports TX |
| 2 | 2 | 100.0 | 5.0 | All ports TX |
| 2 | 2 | 92.0 | 20.0 | All ports TX |
| 3+ | 3 | 60.0 | 1.0 | All ports TX |

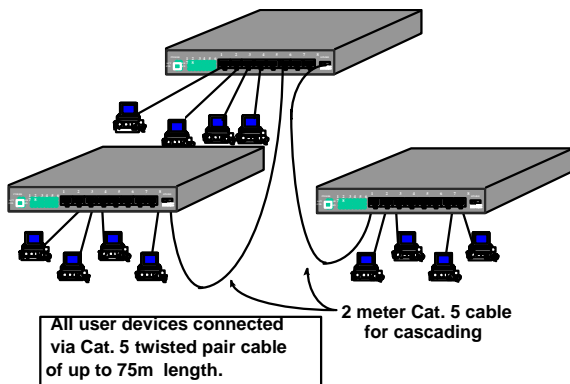

Instructions for connecting the Magnum DS880 Dual-Speed Hubs to the various Fast Ethernet media are given in the following sections.

3.2.3 Connections to NICs which support Auto-Negotiation

The Magnum DS880 Dual-Speed Hub will function properly with NICs (Network Interface Cards) which support Auto-Negotiation. The Magnum DS880 will establish link with any NIC which can send and receive the Fast Link Pulse (FLP) coding for the 100BASE-TX signaling system. When connecting a NIC to the DS880, it may be necessary to reload the NIC drivers on the user device if the NIC has been communicating with a protocol other than 100BASE-TX (such as 10BASE-T). When 100Mb operation is agreed and in use, the 100Mb LINK/ACT LED is illuminated, steady ON if no traffic or blinking when there is traffic.

3.3 Powering the Magnum DS880

Magnum DS880 Dual-Speed Hub incorporates an internal universal power supply, and has a recessed male IEC connector for the AC power cord in the rear. A six-foot 115 VAC 60Hz power cord is supplied with each unit shipped within the United States and Canada.

Each Magnum DS880's auto-ranging power supply supports installation environments where the AC voltage is from 90 to 260 volts with an input frequency between 47 and 63 Hz, and consumes a maximum of 20 watts. In order to power down the unit, simply unplug either end of the AC power cable.

4.0 OPERATION

This chapter describes the function and operation of the Magnum DS880 hubs.

4.1 Dual-Speed Functionality

The Magnum DS880-A handles the two different traffic domains separately (unless it is stacked with a DS880-B). The DS880-B provides switched (bridged) connectivity between the Ethernet (10Mb/s) and Fast Ethernet (100Mb/s) domains. It joins the two network domains for unified operation, and filters/ forwards packets in both directions to maximize bandwidth utilization and performance. Magnum DS880s are hardware plug-and-play devices. There is no software set-up to be done at installation or for maintenance. The functions of the DS880s are described in this manual.

Each time a packet is received on one domain of the bridge module, the decision is taken to either to filter or forward the packet. Errored packets are always filtered. For good packets, the filter and forward decisions are made based on the destination address contained in each packet. If the destination address is on the same domain from which the packet originated, then it is filtered and not forwarded to the other domain. If the destination address is not found to be a match in the address table for the originating domain, then it is forwarded to the other domain. If it is a new node address coming in which the switch did not previously know about, it “learns” the new address and puts it in the correct port address table. See “Address Learning” for more details.

This diagram below shows the filter / forward logic for both domains.

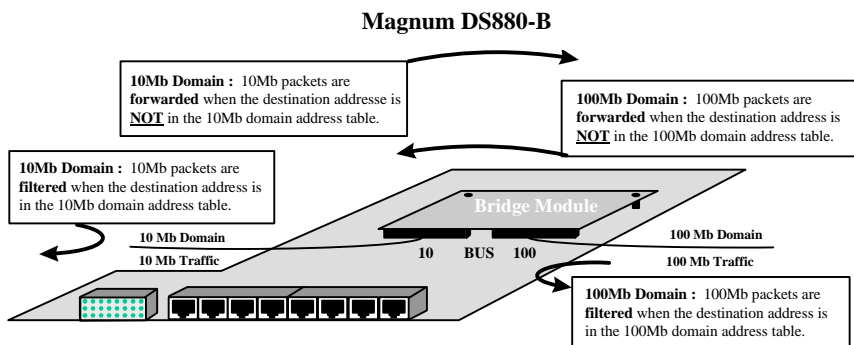

Figure 4.1 : Filtering vs. Forwarding in Dual Speed 880-B

| Packet Source | Source Address | Destination Address | Address Table Maintenance | Filter/Forward Action |
|----------------------|-----------------------|----------------------------|----------------------------------|------------------------------|
| 10 Mb | Not in table | Not in table | Add source to table | Forward |
| 10 Mb | Not in table | In table | Add source to table | Filter |
| 10 Mb | In table | Not in table | None | Forward |
| 10 Mb | In table | In table | None | Filter |
| 100 Mb | Not in table | Not in table | Add source to table | Forward |
| 100 Mb | Not in table | In table | Add source to table | Filter |
| 100 Mb | In table | Not in table | None | Forward |
| 100 Mb | In table | In table | None | Filter |

Table 4.1: DS880 Dual-Speed Hub Functionality

1. Address Learning (Address Table Maintenance)

The Magnum DS880-B bridge module is a state machine design which has a total address table capacity of 8K addresses. With a large address table, a Magnum DS880 can serve the needs of a medium-sized to large network. Table 4.1 shows what filter / forward action the Magnum DS880-B will take in each packet-processing situation, and when a new node address will be added to the internal Address Table. When a new node-address packet comes into a port for the first time, then the new source address is “learned” at the same time that the packet is forwarded. After learning, subsequent packets from the same node address are routinely processed. The address tables are flushed periodically to update the network status and to purge any inactive stations from the tables of both domains.

2. Throughput Increase

By selectively forwarding packets from each domain to the other domain based on its switching (bridging) logic, the Magnum DS880-B increases the available bandwidth for the users on both sides of the network. As shown in Figure 4.1, it keeps the local traffic on each side contained, preventing unnecessary packets and bad packets from traveling to the other domain and using up bandwidth needlessly over there. This results in more available network bandwidth on both sides and a throughput increase on for all users on both domains.

1.1 Software Transparency

4.1.1 The Magnum DS880-A and -B Dual-Speed Hubs need no software set-up and are transparent to system and application software, including network management software.

4.2 Port Speed Settings for 10,100Mbps Or 10/100Mbps Mode only

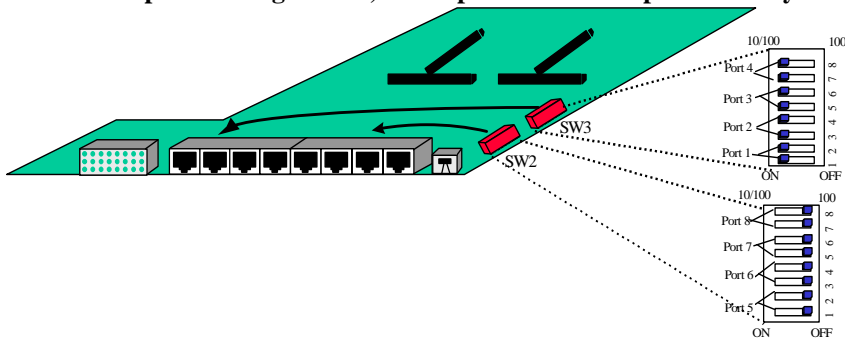

Figure 4.2: Switch Settings for 10/100Mbps and 100Mbps Speed

The latest Magnum DS880 unit is equipped with Switches for setting Port Speed. The SW2 and SW3 switches are located on the right side of the main board as shown in the figure 4.2 above. These switches allow the user to set the speed at 10, 100Mbps or 10/100Mbps auto-sense. The unit has been set at 10/100Mbps at the time of shipping.

The Switch SW3 represents port#1 to 4 and the switch SW2 port#5 to 8 as shown in the Fig 4.2 above. The switches has 8 Dip-switches each. Every two contiguous Dip-switches represent one single port. To fix the speed at 100Mbps, both DIP-switch position have to slide towards the 100 side. In the above Fig 4.2 the Switch SW3 has been fixed 10/100Mbps and Switch SW2 at 100Mbps. Setting the port at 10Mbps is little bit tricky. The user has to slide the odd number of Dip-switch to ON (or 10/100) position and even number to reverse

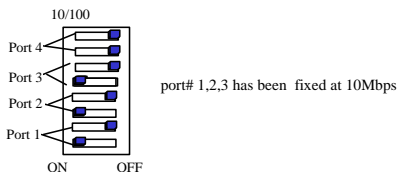

Figure 4.2a Speed settings at 10Mbps (OFF or 100) position as shown in the Fig 4.2a above.

4.3 Auto-negotiation and speed-sensing

All eight RJ-45 ports independently support auto-negotiation for shared 10BASE-T and 100BASE-TX modes. When the '100' LED is flashing, it means that the corresponding port is sending out auto-negotiation pluses out that port. When a connection is made, the other device should respond and both sides should agree to the speed being advertised. Depending upon the device connected, it will either advertise at 10Mb or 100Mb speeds. Silence means the port defaults to 10Mb.

When the '100' LED is steady ON, the port has auto-negotiated for 100Mb operation and is processing packets at 100Mb/s, When it is OFF, it is at 10Mb/s. If a DS880 port is connected to a non-negotiating device, it will default to 10Mb speed. Since Magnum DS880s are hubs, they always operate in the shared or half-duplex mode on all ports.

4.4 LED's

- PWR** : Illuminates GREEN to indicate AC power is applied to the unit.
- BR** : Bridge Module LED-
ON when a bridge module is present in the unit (model DS880-B)
OFF when no bridge module is present (model DS880-A)
- COL** : Two collision LED's, one for each traffic domain, 10 and 100Mb
Blinks intermittently when a collision occurs.
- ACT** : Activity (Send or Receive) for each traffic domain, 10 and 100Mb
- 100** : Speed LED, per port. Flashing when auto-negotiating (No LINK)
Steady ON when the port speed is 100Mbps, OFF for 10Mbps
- LK** : LINK LED, per port. Illuminates GREEN when a working connection is established between the port and the attached device.
- RX** : Activity LED, per port. Flashes GREEN to indicate that the port is receiving data from the attached device, i.e., there is activity on the port.

4.5 Up-link Switch

The Magnum DS880s have one up-link slide switch, used with port 8. This allows repeater-to-repeater connections without a special cross-over cable. It works the same for 10Mb or 100Mb connections.

UP-LINK



Set the slide switch to the “=” position for twisted pair cabling from the DS880 port to a user device, or to the “X” position for cross-over or up-link segment connections from the DS880 port to a repeater or hub. Verify proper switch position by noting the port's LINK LED status, which is illuminated when a proper link is made.

5.0 TROUBLESHOOTING

All Magnum Ethernet products are designed to provide reliability and consistently high performance in all network environments. The installation of the Magnum DS880 10/100 Dual Speed Stackable Hub is a straightforward procedure (see INSTALLATION, Section 2.6); the operation is also straightforward and is discussed in Section 4.

Should problems develop during installation or operation, this section is intended to help locate, identify and correct these types of problems. Please follow the suggestions listed below prior to contacting your supplier. However, if you are unsure of the procedures described in this section or if the Magnum DS880 10/100 Dual Speed Stackable Hub is not performing as expected, do not attempt to repair the unit; instead contact your supplier for assistance or contact GarrettCom Customer Support.

5.1 Before Calling for Assistance

1. If difficulty is encountered when installing or operating the unit, refer back to the Installation Section of the applicable chapter of this manual. Also check to make sure that the various components of the network are interoperable.
2. Check the cables and connectors to ensure that they have been properly connected and the cables/wires have not been crimped or in some way impaired during installation. (About 90% of network downtime can be attributed to wiring and connector problems.)
3. Make sure that an AC power cord is properly attached to each Magnum DS880 10/100 Dual Speed Stackable Hub unit. Be certain that each AC power cord is plugged into a functioning electrical outlet. Use the PWR LEDs to verify each unit is receiving power.
4. If the problem is isolated to a network device other than the Magnum DS880 10/100 Dual Speed Stackable Hub product, it is recommended that the problem device is replaced with a known good device. Verify whether or not the problem is corrected. If not, go to Step 5 below. If the problem is corrected, the Magnum DS880 10/100 Dual Speed Stackable Hub and its associated cables are functioning properly.
5. If the problem continues after completing Step 4 above, contact your supplier of the Magnum DS880 10/100 Dual Speed Stackable Hubs unit or if unknown, contact GarrettCom, Inc. by fax, phone or email (*support@garrettcom.com*) for assistance.

5.2 When Calling for Assistance

Please be prepared to provide the following information.

1. A complete description of the problem, including the following points:
 - a. The nature and duration of the problem;
 - b. Situations when the problem occurs;
 - c. The components involved in the problem;
 - d. Any particular application that, when used, appears to create the problem;
2. An accurate list of GarrettCom product model(s) involved, with serial number(s). Include the date(s) that you purchased the products from your supplier.
3. It is useful to include other network equipment models and related hardware, including personal computers, workstations, terminals and printers; plus, the various network media types being used.
4. A record of changes that have been made to your network configuration prior to the occurrence of the problem. Any changes to system administration procedures should all be noted in this record.

5.3 Return Material Authorization (RMA) Procedure

All returns for repair must be accompanied by a Return Material Authorization (RMA) number. To obtain an RMA number, please use this URL - https://rma.garrettcom.com/rma/rma_request_noaccount.php to fill out the form. Please have the following information readily available:

Name and phone number of your contact person.
Name of your company / institution
Your shipping address
Product name
Serial Number (or Invoice Number)
Packing List Number (or Sales Order Number)
Date of installation
Failure symptoms, including a full description of the problem.

GarrettCom will carefully test and evaluate all returned products, will repair products that are under warranty at no charge, and will return the warranty-repaired units to the sender with shipping charges prepaid (see Warranty Information, Appendix A, for complete details). However, if the problem or condition causing the return cannot be duplicated by GarrettCom, the unit will be returned as:

No Problem Found.

GarrettCom reserves the right to charge for the testing of non-defective units under warranty. Testing and repair of product that is not under warranty will result in a customer (user) charge.

5.4 Shipping and Packaging Information

Should you need to ship the unit back to GarrettCom, please follow these instructions:

1. Package the unit carefully. It is recommended that you use the original container if available. Units should be wrapped in a "bubble-wrap" plastic sheet or bag for shipping protection. (You may retain all connectors and this Installation Guide.)

CAUTION: Do not pack the unit in Styrofoam "popcorn" type packing material. This material may cause electro-static shock damage to the unit.

2. Clearly mark the Return Material Authorization (RMA) number on the outside of the shipping container.
3. GarrettCom is not responsible for your return shipping charges.
4. Ship the package to:

**GarrettCom, Inc.
47823 Westinghouse Dr.
Fremont, CA 94539-7437
Attn.: Customer Service**

APPENDIX A: WARRANTY INFORMATION

GarrettCom, Inc. warrants its products to be free from defects in materials and workmanship for a period of three (3) years from the date of shipment by GarrettCom.

During this warranty period, GarrettCom will repair or, at its option, replace components in the products that prove to be defective at no charge other than shipping and handling, provided that the product is returned pre-paid to GarrettCom.

This warranty will not be effective if, in the opinion of GarrettCom, the product has been damaged by misuse, misapplication, or as a result of service or modification other than by GarrettCom.

GarrettCom reserves the right to make a charge for handling and inspecting any product returned for warranty repair which turns out not to be faulty.

Please complete the warranty card as this acts as a product registration, and mail it to GarrettCom within two weeks of your purchase.

APPENDIX B : Optional 48V DC Power Supply, Addendum**B1.0 SPECIFICATIONS - FOR DUAL-SPEED DS880 HUBS****Power Supply (Internal 48 VDC Option)**

DC Power Connector: 3 terminals: “-“, “GND”, “+”

Input Voltage: 36 - 70 VDC (auto-ranging)

Power Consumption: Model DS880: 12 watt typical, 20 watts max.

With the exception of the power supply, all specifications and functions of Magnum DS880-48VDC models are identical to those listed in Section 1.

B2.0 48V DC SOURCE OPTION, THEORY OF OPERATION

The 48VDC power option is designed using diodes inside on each DC power input line behind the two external power connection terminals, so that the power from an external source can only flow into the hub. This allows the hub to operate only whenever DC power is correctly applied to the two inputs. It protects the hub from incorrect DC input connections. An incorrect

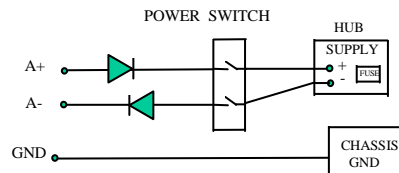

polarity connection, for example, will neither effect the hub, nor its power supply internally, nor will it blow the fuse in the internal power supply.

The power switch (included on premium-priced NEBS-certified units only) is used for powering the hub on and off when it is placed into or taken out of service.

B3.0 APPLICATIONS

Magnum DS880 Dual-Speed Hubs are easily installed in a variety of applications where 48 VDC power is used as the primary power source. The 48VDC power configuration provides an Ethernet networking solution utilizing a special power supply in hubs with a proven track record.

The solution is particularly useful in the telecommunication industry, where it is common for facilities to operate on 48VDC power. Such companies include regular and wireless telephone service providers, Internet Service Providers (ISPs) and other communication companies. In addition, many high availability equipment services, such as broadcasters, publishers, newspaper operations, brokerage firms and other facilities often use a battery backup system to maintain operations in the event of a power failure. It is also frequently used for computer system backup, management and operations monitoring equipment.

B4.0 INSTALLATION

This section describes the installation of the 48 VDC power source leads to the 48 VDC power terminal block on the Magnum DS880s. (see figure below).

Figure B4.1: 48 VDC Terminal Block on Magnum DS880-48VDC

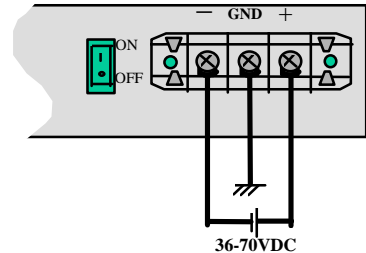

The 48 VDC terminal block on the Magnum DS880s is located on the rear of the unit and is equipped with three (3) screw-down lead posts. The leads are

identified as negative (-), positive (+), and chassis ground (GND). The actual connection procedure is very straightforward. **To avoid the confusion of -48V or +48V power supply, use a digital voltmeter to measure the output voltage and figure out the +VE Lead. The more +VE voltage terminal lead from the +48V or -48V power supply should be connected to the post leveled “+” and then the rest. Ensure that each lead is securely tightened.**

On the premium-priced NEBS-compliant Magnum DS880-48V models, an ON-OFF switch is included, located in the rear at the power input. This can be used in conjunction with power connections, and as a RESET for the hub’s electronics.

B4.1 UL Requirements

1. *Minimum 14 AWG cable for connection to a Centralized DC power source.*
2. *Fastening torque of the lugs on the terminal block: 9 inch pound max.*
3. *Centralized DC Power Source cable securement, use at least four cable ties to secure the cable to the rack at least 4 inches apart with the first one located within 6 inches of the terminal block.*

B5.0 OPERATION

Operation of the Magnum DS880s with the optional 48VDC power supply is identical to that of the standard AC-powered models.

B6.0 TROUBLESHOOTING

Please refer to Section 5.0 for troubleshooting

Free Manuals Download Website

<http://myh66.com>

<http://usermanuals.us>

<http://www.somanuals.com>

<http://www.4manuals.cc>

<http://www.manual-lib.com>

<http://www.404manual.com>

<http://www.luxmanual.com>

<http://aubethermostatmanual.com>

Golf course search by state

<http://golfingnear.com>

Email search by domain

<http://emailbydomain.com>

Auto manuals search

<http://auto.somanuals.com>

TV manuals search

<http://tv.somanuals.com>