

This service manual covers adjustment, disassembly, operation, preventative maintenance, troubleshooting procedures and contains an illustrated parts list for the GBC Shredmaster 5020S/5230S shredder. The GBC Shredmaster 5020S/5230S shredders are designed for centralized use in copier areas.

Innovative engineering has provided these shredders with the following operating and safety features:

- 1. Automatic Operation** - The unit begins to operate when paper enters the shredder throat area. The motor then will stop running when the paper has cleared the cutting head and after the shredder has timed out.
- 2. Overload Warning** - Whenever the capacity of the shredder is exceeded the unit will stop shredding and the "Reverse" icon will illuminate.
- 3. Bin Full** - When the shred bag becomes full, the motor automatically turns off and the "Bin full" icon will illuminate. The shredder will not operate until the shredded material is either compacted or emptied.
- 4. Door Ajar** - When the door of the shredder is not fully closed, the "Door Ajar" icon will illuminate. This is a safety feature that will only allow the shredder to operate when the cabinet door is in the closed position.

Before attempting any repairs on the 5020S/5230S shredder, review the operating instructions first to gain experience and familiarity with its operation. You will then be better prepared to use the remaining sections of this manual to troubleshoot and repair the shredder.

5020S

Required**Electrical****Service:** 115VAC +/- 10%, 60 Hz, 15 Amp**Electrical Rating:** 115V AC 4.6A, @ 60Hz**Duty Cycle:** Continuous**Weight with****Cabinet:** 99.5 lbs.**Shredding****Speed:** 30 FPM @ 1 sheet**Shred Size:** 1/4" (6mm)**ThroatWidth:** 15 (38.1cm)**Capacity:** 12-14 sheets of 20# Bond Paper

5230S

Required**Electrical****Service:** 115VAC +/- 10%, 60 Hz, 15 Amp**Electrical Rating:** 115V AC 4.6A, @ 60Hz**Duty Cycle:** Continuous**Weight with****Cabinet:** 99.0 lbs.**Shredding****Speed:** 45 FPM @ 1 sheet**Shred Size:** 3/16" (4mm)**ThroatWidth:** 15 (38.1cm)**Capacity:** 13-15 sheets of 20# Bond Paper

IMPORTANT SAFETY INSTRUCTIONS

Your safety as well as the safety of others is important to GBC. In this instruction manual and on the product are important safety messages. Read these messages carefully.

 The safety alert symbol precedes each safety message in this instruction manual and on the product. This symbol indicates a potential personal safety hazard that could hurt you or others, as well as cause product or property damage. Do not connect this unit to electrical power or attempt to operate it before you have read these operating instructions. Save these instructions for later use.

The following two warnings are found on the bottom of the product:





This safety message means that you could be seriously hurt or killed if you open the product and expose yourself to hazardous voltage.











This safety message means that you could be seriously hurt if you place your hands in the discharge shoot.

The following ISO and IEC symbols appear on this product, and their meanings are as follows:

-  Means Power ON
-  Means OFF
-  Means REVERSE

The symbols which become illuminated are:

-  Means Power ON
-  Means the shred bin is full.
-  Means the cabinet door is open.
-  Means an overload has occurred. Depress the R side of the rocker switch

-  This means you should be careful because long hair can become entangled in the cutting head. This could hurt you.
-  This means don't reach into the feed opening of the cutting head. This could hurt you.
-  This means be careful of ties and other loose clothing which could become entangled in the cutting head. This could hurt you.
-  This means you should be careful of loose jewelry which could become entangled in the cutting head. This could hurt you.

ELECTRICAL SAFEGUARDS

- Unplug your shredder before moving it, emptying the shred bag, or when it is not in use for an extended period of time.
- Do not operate with a damaged power supply cord or plug, after it malfunctions, or after it has been damaged in any manner.
- Do not overload electrical outlets beyond capacity as this can result in fire or electrical shock.
- The socket-outlet should be installed near the equipment and shall be easily accessible.
- Do not alter attachment plug. The plug is configured for the appropriate electrical supply.

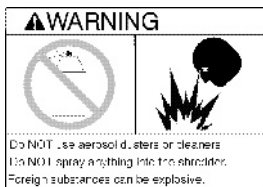

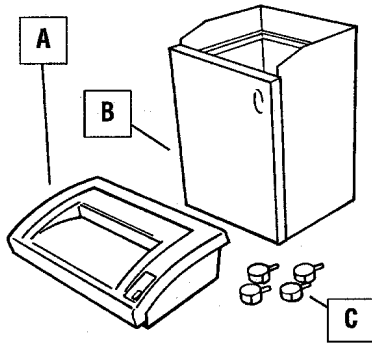

SET UP-FIGURE 2.A.

Caution! Shredders are heavy equipment (see "Shredder Head Weight" in the "Specifications" section of this Manual). To insure proper installation and avoid injury GBC recommends that two people set up this unit.

5200 Series Models Only:

To protect against damage your shredder has been shipped in two parts, the shredder head (A) and the cabinet (B).

3200-4200 Series Models Only:

To protect against damage your shredder has been shipped in three parts, the shredder head (A), the cabinet (B) and the casters (C).

FIGURE 1. Begin set up by lying the cabinet on its back and inserting the casters into the sockets at the four corners of the cabinet bottom. Once the casters are fully inserted turn the cabinet upright.

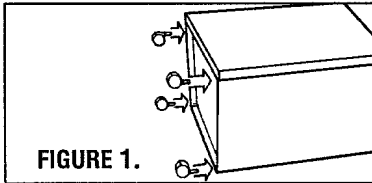

FIGURE 1.

All Models:

FIGURE 2.A.

Caution! Use care not to pinch your fingers between the shredder head and cabinet. Handle shredder head as illustrated.

FIGURE 2.B. Open the cabinet door fully, lift the shredder head by the outside front and back edges using two people on each side. Angle the shredder head slightly downwards from the front and lower onto the cabinet. Once properly installed, a uniform gap of approximately a 1.6mm will be visible from the front.

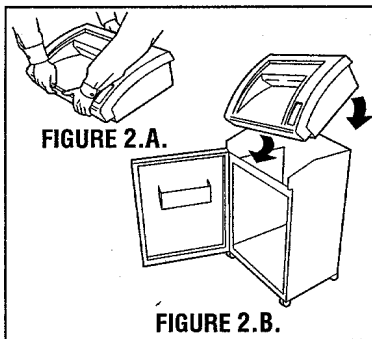

FIGURE 2.A.

FIGURE 2.B.

FIGURE 3. Remove the wire bag rim and place one of the starter bags onto the rim. Slide the rim with bag back into the cabinet. Close the cabinet door.

Your shredder is ready for use!

OPERATION-FIGURE 4.

Connect power cord to an appropriate power source. Press the rocker switch (A) to the on "I" position. When the shredder is properly set up with cabinet door fully closed the Power On light (B) will illuminate.

You are now ready to shred!

To shred simply insert paper into the throat of the unit. Once your document has activated the Automatic On switch the unit will start and then will stop once your document is shredded.

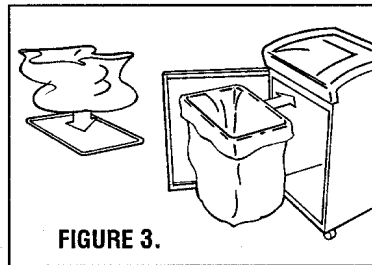

FIGURE 3.

BIN FULL 

In order to prevent shreds from backing up into the cutters and jamming your shredder this unit features an automatic bin full shut off. Once the shred bin is full the unit will shut off automatically and the Bin Full light (C) will illuminate. You can now either compact the shreds and continue shredding, or empty the shred bag.

NOTE: For safety reasons, whenever the cabinet door has been opened this unit will not operate until the door is closed and the unit is switched off and then back on.

DOOR AJAR 

Your shredder is equipped with a safety interlock which will not allow the unit to operate if the cabinet door is open. The Door Ajar light (D) will illuminate if your cabinet door is not fully closed.

OVERLOAD **R**

If too much paper is inserted into the throat of the unit the shredder will sense an overload and shut off automatically to avoid unnecessary motor heating and the Overload Light (E) will illuminate. To clear the overload, switch the unit to Reverse "R" mode until the paper is clear of the throat area. Switch your unit back into the Power On position, separate your pages into smaller sets and shred.

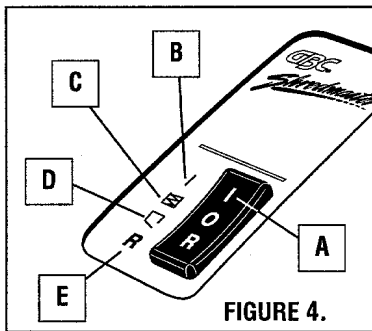

FIGURE 4.

Free Manuals Download Website

<http://myh66.com>

<http://usermanuals.us>

<http://www.somanuals.com>

<http://www.4manuals.cc>

<http://www.manual-lib.com>

<http://www.404manual.com>

<http://www.luxmanual.com>

<http://aubethermostatmanual.com>

Golf course search by state

<http://golfingnear.com>

Email search by domain

<http://emailbydomain.com>

Auto manuals search

<http://auto.somanuals.com>

TV manuals search

<http://tv.somanuals.com>