



Zoneline® Vertical Air Conditioners

Safety Instructions..... 2

Operating Instructions

Controls—Dip Switches 3-5

Controls—Terminal

Connections 6, 7

On/Off Switch 8

Ventilation Control 8

Care and Cleaning

Air Filters 9

Base Pan 9

Exhaust Coils..... 9

Installation Instructions

Electrical Supply.....11-13

Installing the Zoneline14-21

Preparation 10

Servicing..... 22

Troubleshooting Tips 23

Normal Operating Sounds 24

Consumer Support

Consumer Support..... Back Cover

Warranty 27

**Owner's Manual and
Installation Instructions**

Cool Only, Heat/Cool and
Heat Pump Models
8500 Series

Español

For a Spanish version of this manual, visit our Website at GEAppliances.com.

Para consultar una version en español de este manual de instrucciones, visite nuestro sitio de internet GEAppliances.com.

Française

For a French version of this manual, visit our Website at GEAppliances.com.

Pour une version française de ce manuel d'utilisation, veuillez visiter notre site web à l'adresse GEAppliances.com.

Write the model and serial numbers here:

Model # _____

Serial # _____

You can find them on a label on the front case panel.

IMPORTANT SAFETY INFORMATION. READ ALL INSTRUCTIONS BEFORE USING.

WARNING!

Risk of electric shock. Can cause injury or death. For your safety, the information in this manual must be followed to minimize the risk of fire, electric shock or personal injury.



SAFETY PRECAUTIONS

- This Zoneline must be properly installed in accordance with the Installation Instructions before it is used. See the Installation Instructions in the back of this manual.
 - Replace immediately all electric service cords that have become frayed or otherwise damaged. A damaged power supply cord must be replaced with a new power supply cord obtained from the manufacturer and not repaired. Do not use a cord that shows cracks or abrasion damage along its length or at either the plug or connector end.
 - Product must be operated with the electrical plug supplied with the product. Do not replace the electrical plug supplied with the product.
 - If the receptacle does not match the plug, the receptacle must be changed out by a qualified electrician.
 - Unplug or disconnect the Zoneline at the fuse box or circuit breaker before making any repairs.
- NOTE: We strongly recommend that any servicing be performed by a qualified individual.
- All air conditioners contain refrigerants, which under federal law must be removed prior to product disposal. If you are getting rid of an old product with refrigerants, check with the company handling disposal about what to do.
 - These R410A Air Conditioner Systems require contractors and technicians to use tools, equipment and safety standards approved for use with this refrigerant. DO NOT use equipment certified for R22 refrigerant only.



READ AND FOLLOW THIS SAFETY INFORMATION CAREFULLY.

SAVE THESE INSTRUCTIONS

Controls–Dip Switches

The dip switch controls are located behind the front case panel, through an opening on the front of the unit.

To access the dip switches, remove the front case panel by removing the filter, taking out the four front screws, the upper two screws from the top of the panel and the shipping screws on each side, if present. (Discard the four side shipping screws, if present).

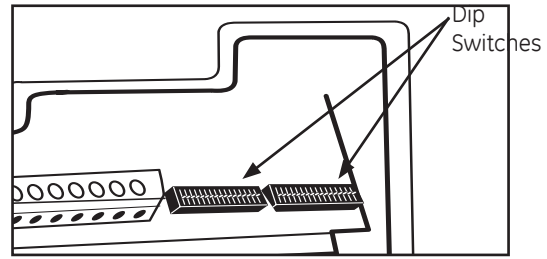

NOTE: The owner is responsible for setting the appropriate dip switches and connecting terminals.

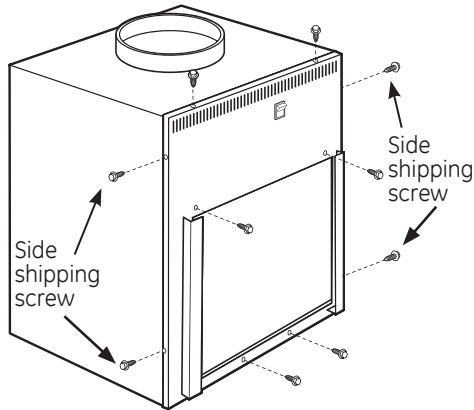

TL3 (C) (Temp. Limit 3–Cool)
 TL2 (C) (Temp. Limit 2–Cool)
 TL1 (C) (Temp. Limit 1–Cool)

TL1 (H) (Temp. Limit 1–Heat)
 TL2 (H) (Temp. Limit 2–Heat)
 TL3 (H) (Temp. Limit 3–Heat)

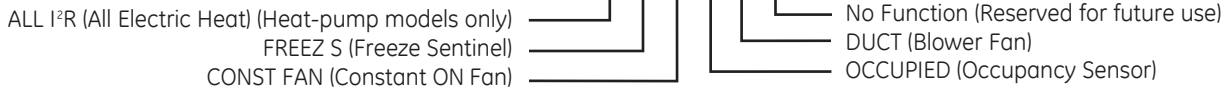

All Electric Heat (Heat pump models only)

When this switch is enabled (UP), heat pump operation is locked out, causing the unit to provide only electric resistance heat.

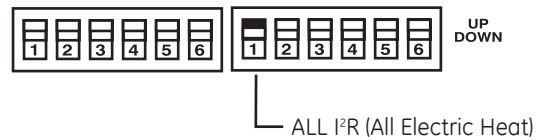

Controls—dip switches.

Freeze Sentinel (Requires room air sensor kit—RAVRMS)

When this switch is enabled (UP), it turns OFF the freeze sentinel protection feature. With the switch disabled (DOWN), the freeze sentinel is activated which automatically provides heat without user interface. This helps to prevent plumbing damage by turning the heater and fans ON at 41° F and OFF at 46° F.

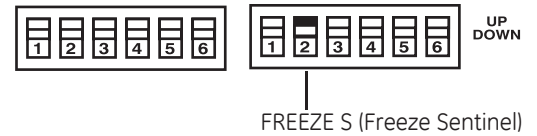

Constant ON Fan

When this switch is enabled (UP), it allows the fan to run continuously.

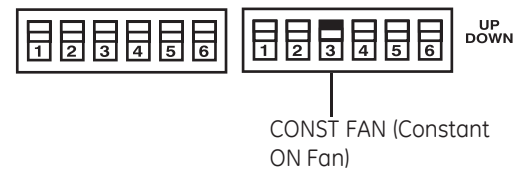

Occupancy Sensor (Field Supplied)

When this switch is enabled (UP), it allows the unit to utilize an infrared motion sensor and a door switch for occupancy detection. This feature combined with field devices automatically cycles the unit between normal operation and a preset energy management operation.

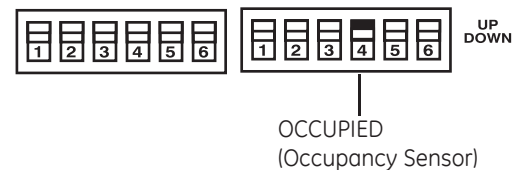

Duct

The duct select function allows the indoor fan to be operated at two variable fan speeds. When this switch is enabled (UP), the unit automatically selects either high or middle fan speed (for longer ductwork applications). When set in the down position, the unit is automatically operated in either the middle or low fan speed (for shorter ductwork applications).

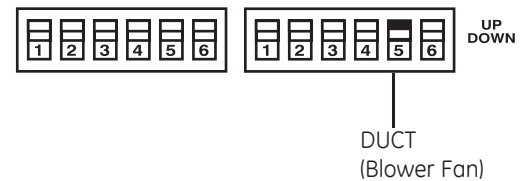

Temperature Limiting (Requires room air sensor kit-RAVRMS)

Temperature limiting can reduce energy costs by limiting the lowest temperature that can be set for cooling and the highest temperature that can be set for heating. Temperature limiting is controlled by switches 1–6 on the top block

of auxiliary controls. The first three switches are used to select the cooling limits. The next three switches are used to control the heating limits.

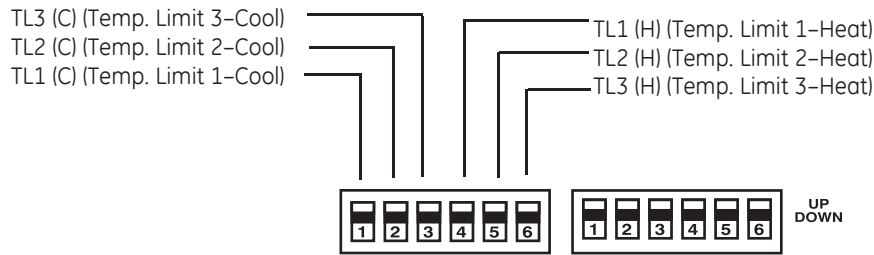

Temperature limiting during COOL mode (all temperatures shown in °F)			
UP	DOWN	Minimum	Maximum
NONE	1, 2, 3	60°	85°
1	2, 3	64°	85°
1, 2	3	66°	85°
2	1, 3	68°	85°
2,3	1	70°	85°
1, 2, 3	NONE	72°	85°
1, 3	2	74°	85°
3	1, 2	76°	85°

Temperature limiting during HEAT mode (all temperatures shown in °F)*			
UP	DOWN	Minimum	Maximum
NONE	4, 5, 6	60°	85°
4	5, 6	60°	80°
4, 5	6	60°	78°
5	4, 6	60°	76°
5,6	4	60°	74°
4, 5, 6	NONE	60°	72°
4, 6	5	60°	70°
6	4, 5	60°	65°

* Not applicable to Cool-Only models

Controls—terminal connections.

Controls—Terminal Connections

The terminal connections are located behind the front case panel through an opening on the front of the unit.

To access the terminal connections, remove the front panel by removing the filter, taking out the four front screws, the upper two screws from the top of the panel and the shipping screws on each side, if present. (Discard the four side shipping screws, if present.)

Insert the building hook-up wires into the bottom of the terminals and tighten screws securely to make the desired connections.

Route the wires from the terminal connections through the unit wire guides and out through the case wire guide.

NOTE: The owner is responsible for setting the appropriate dip switches and connecting terminals.

CAUTION:

Improper CDC wiring may damage the Zoneline electronics or cause erratic Zoneline operation. No common bussing is permitted. A separate wire pair must be run from each separate controlling switch to each individual Zoneline.

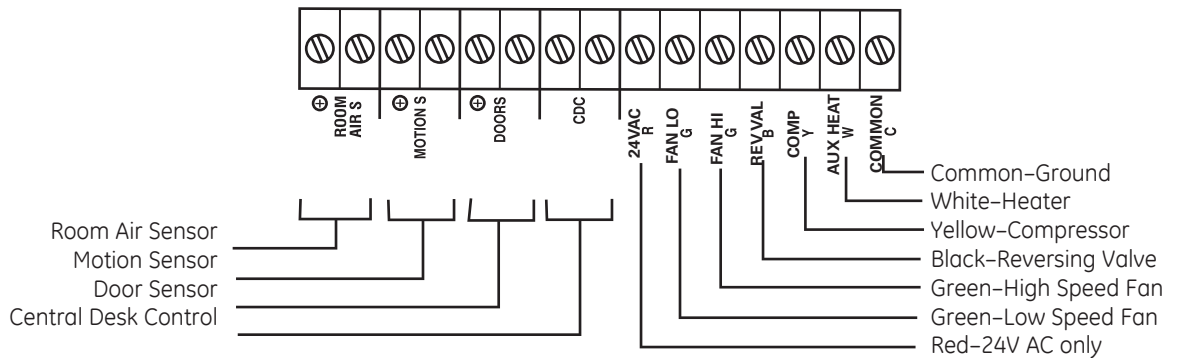
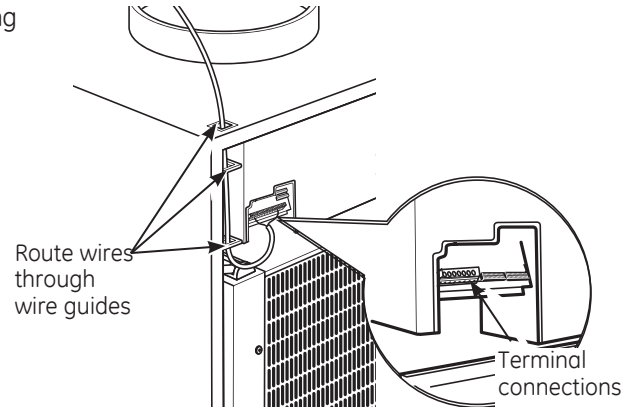

Room Air Sensor (Requires room air sensor kit – RAVRMS)

When connected, the room air sensor will allow utilization of the temperature limiting and freeze sentinel features.

NOTE: If GE thermostat RAK148D1, RAK148P1 or RAK164D1, RAK164P1 is used with the unit, the room sensor kit is not needed for temperature limiting since this feature is incorporated in the thermostats.

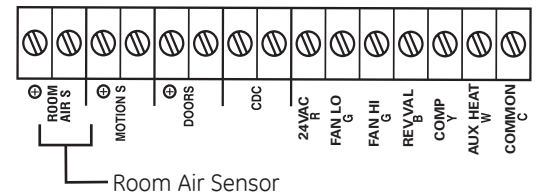

Hydronic Heating (Requires Hydronic Heating Kit – RAVHW1, RAVHW2 or RAVHW3)

Required connections for hydronic heating kit.

NOTE: R, W, C terminal connections will also be connected to the remote thermostat if applicable.

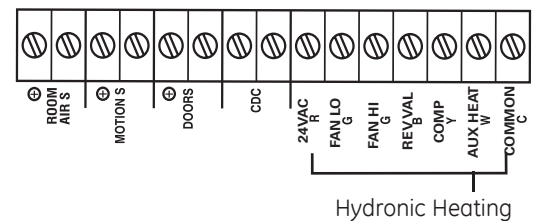

Motion Sensor (Obtained locally)

The Occupancy Sensor dip switch must be in the up position to use this feature.

When connected, the wall mounted motion sensor will detect motion in the room and automatically cycle the unit between normal operation and energy management operation.

The door and motion sensors work together to automatically cycle the unit between normal operation and energy management operation.

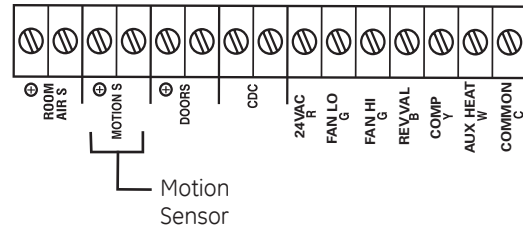

Door Sensor (Obtained locally)

The Occupancy Sensor dip switch must be in the up position to use this feature.

When connected, the door sensor will detect when the door in the room is opened or closed. This feature must be used in conjunction with the motion sensor.

The door and motion sensors work together to automatically cycle the unit between normal and energy management operations.

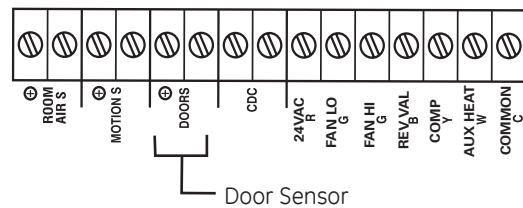

Central Desk Control

When connected, the unit lock-out is released and it can be turned ON or OFF with a switch located at the Central Desk Control. A separate wire pair must be run from each separate controlling switch to each individual Zoneline. A 24V AC circuit powers the CDC system. No external power is required.

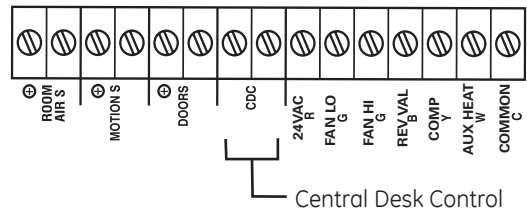

Remote Thermostat

The unit will be controlled by a remote thermostat.

IMPORTANT:

The Zoneline thermostat connections provide 24V AC only.

If using a digital/electronic wall thermostat, you must set it to the 24V AC setting. See the Installation Instructions for the wall thermostat.

NOTICE:

Damage to a wall thermostat or to the Zoneline electronics can result from improper connections. Exercise extra attention when connecting blue and black wires. No line voltage connections should be made to any circuit in the thermostat. Isolate all wires in building from line voltage.

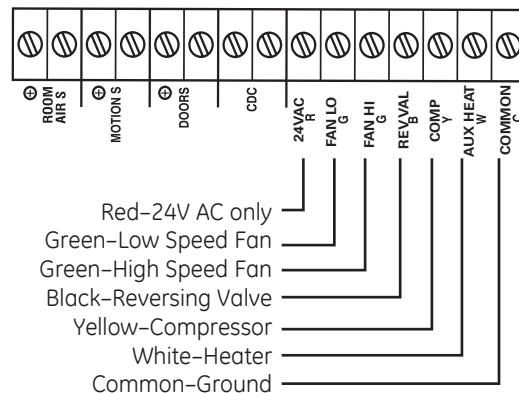

Other features of your Zoneline.

On/Off Switch

The unit on/off switch is located on the front of the Zoneline.

To turn on the unit, press the top of the switch in.

To turn off the unit, press the bottom of the switch in.

NOTE: The on/off switch does not remove power from the unit.

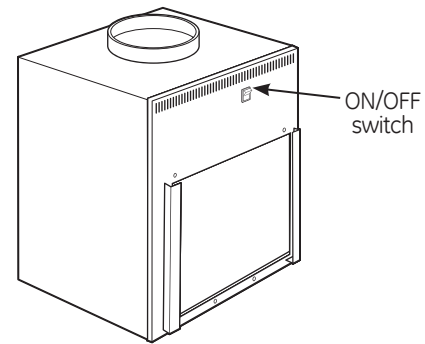

Ventilation Control

The ventilation control lever is located on the left side of the Zoneline unit, behind the front case panel.

To access the ventilation control lever, remove the front panel by removing the filter, taking out the four front screws, the upper two screws from the top of the panel and the shipping screws on each side, if present. (Discard the four side shipping screws, if present).

When the lever is in the **CLOSE** position, only the air inside the room is circulated and filtered.

When the lever is in the **OPEN** position, some outdoor air will be drawn into the room. This will reduce the heating or cooling efficiency.

To close the vent, push the vent lever handle down, pull it forward and lock it up in place.

To open the vent, push the vent lever handle down, push it back and lock it up in place.

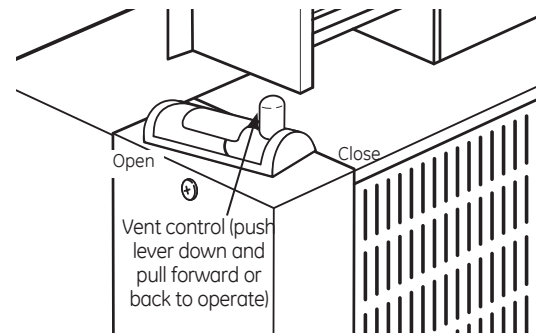

Energy Tip: Keep the vent control in the **CLOSE** position. The room air will be filtered and circulated.

NOTE: Ventilation openings are not intended to be the source of make-up air for building ventilation systems due to the additional heating and cooling loads generated.

About Heat Pumps (on some models)

Heat pumps can reduce operating costs by exchanging heat from the outside air—even when the outside temperature is below freezing—and releasing that heat indoors.

To get the best economic benefit from your heat pump, don't change the room thermostat setting very often. Raising the heat setting 2–3 degrees will cause the Zoneline to use its electric heating elements in order to reach the new temperature setting quickly.

There is a three minute minimum compressor run time at any setting to prevent short cycling.

The indoor fan motor starts before the compressor and stops after the compressor cycles off.

The electric heating elements use much more electricity than heat pumps and cost more to operate.

Do Not Operate the Air Conditioner (cool mode) in Freezing Outdoor Conditions

Air conditioners are not designed for use when freezing outdoor conditions exist. They must not be used in freezing outdoor conditions.

Turn off the Zonline and disconnect the power supply before cleaning.

Indoor/Outdoor Coils

The exhaust coils on the Zonline should be checked regularly. If they are clogged with dirt or soot, they may be professionally steam cleaned by your GE service center. You will need to remove the unit from the case to inspect the coils because the dirt build-up occurs on the exhaust side.

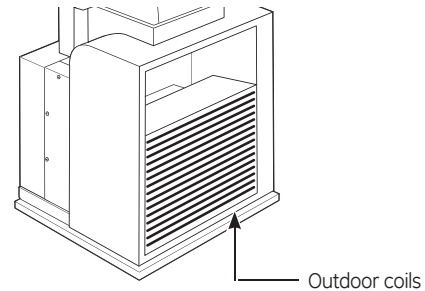

Have the coils cleaned regularly.

Drain

Clean the drain system regularly to prevent clogging.

Base Pan

In some installations, dirt or other debris may be blown into the unit from the outside and settle in the base pan (the bottom of the unit).

In some areas of the United States, a "gel-like" substance may be present in the base pan.

Check it periodically and clean, if necessary.

Air Filters

To maintain optimum performance, change the filter at least every 30 days.

The most important thing you can do to maintain the Zonline is to change the filter at least every 30 days. Dirty filters reduce cooling, heating and air flow.

Changing the filter will: Decrease cost of operation, save energy, prevent clogged heat exchanger coils and reduce the risk of premature component failure.

NOTICE: Do not operate the Zonline without the filter in place. If a filter becomes torn or damaged, it should be replaced immediately.

Operating without the filter in place or with a damaged filter will allow dirt and dust to reach the indoor coil and reduce the cooling, heating, airflow and efficiency of the unit.

Replacement filters should be purchased from your local retailer where air conditioner and furnace accessories are sold.

Filter size required is 20" x 20" x 1".

To remove and replace the filter:

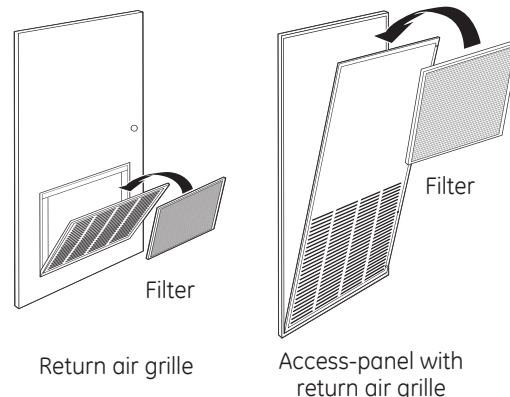
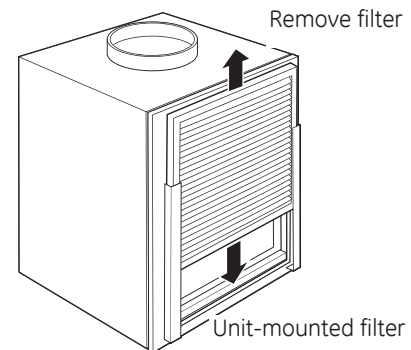

Installation Instructions

Zoneline Air Conditioners

Questions? Visit our Website at: GEAppliances.com or call 800.GE.CARES (800.432.2737).

BEFORE YOU BEGIN

Read these instructions completely and carefully.

- **IMPORTANT** — Save these instructions for local inspector's use.
- **IMPORTANT** — Observe all governing codes and ordinances.
- **Note to Installer** — Be sure to leave these instructions with the owner.
- **Note to Owner** — Keep these instructions for future reference.
- Proper installation is the responsibility of the installer.
- Product failure due to improper installation is not covered under the Warranty.
- You **MUST** use all supplied parts and use proper installation procedures as described in these instructions when installing this air conditioner.

TOOLS YOU WILL NEED



Phillips screwdriver



Adjustable wrench



Saw



Hammer

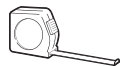

Tape measure

IMPORTANT ELECTRICAL SAFETY—READ CAREFULLY

⚠ WARNING: RISK OF ELECTRIC SHOCK.

- All electrical connections and wiring **MUST** be installed by a qualified electrician.
- Follow the National Electrical Code (NEC) and/or local codes and ordinances.
- For personal safety, this Zoneline unit and case must be properly grounded.
- Protective devices (fuses or circuit breakers) acceptable for Zoneline installations are specified on the nameplate of each unit.
- Do not use an extension cord with this unit.
- Aluminum building wiring may present special problems—consult a qualified electrician.
- When the unit is not running there is still voltage to the electrical controls.
- Disconnect the power to the unit before servicing by:
 1. Removing the power cord (if it has one) from the wall receptacle.OR
 2. Removing the branch circuit fuses or turning the circuit breakers off at the panel.

⚠ WARNING: RISK OF ELECTRIC SHOCK.

Can cause injury or death. This appliance must be properly grounded. Where a 2-prong wall outlet is encountered, it is your responsibility and obligation to have it replaced with a properly grounded 3-prong outlet.

Installation Instructions

ELECTRICAL REQUIREMENTS

- Use **ONLY** the wiring size recommended for single outlet branch circuit.
- Proper current protection is the responsibility of the owner.

Recommended branch circuit wire sizes*	
Nameplate maximum circuit breaker size	AWG Wire size**
15A	14
20A	12
30A	10

AWG – American Wire Gauge
 * Single circuit breaker from main box
 ** Based on copper wire, single insulated conductor at 60° C

NOTE: Use copper conductors only.

230/208 VOLT ELECTRICAL SUPPLY

A power supply kit must be used to supply power to the Zoneline unit. The appropriate kit is determined by the voltage, the means of electrical connection and the amperage of the branch circuit. See the POWER CONNECTION CHART on page 13 to select the appropriate kit.

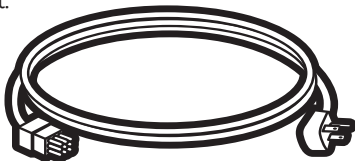

Power supply kit

All wiring, including installation of the receptacle, must be in accordance with the NEC and local codes, ordinances and regulations.



Tandem
15 Amp



Perpendicular
20 Amp



Large Tandem
30 Amp

230/208 volt receptacle configuration

FOR 230/208 VOLT CORD CONNECTIONS ONLY

1. Remove the front panel by taking out the four front screws, the upper two screws from the top of the panel and the shipping screws on each side, if present. (Discard the four side shipping screws, if present.)

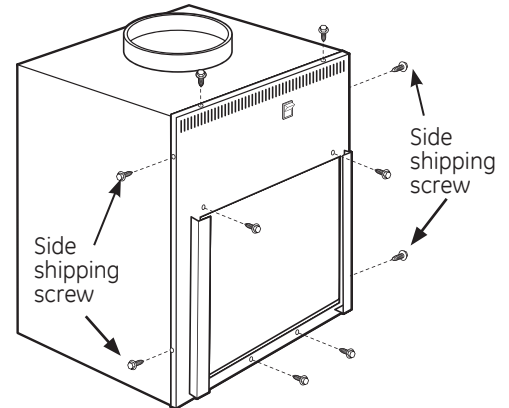

2. Remove the junction box cover and the junction box and discard.

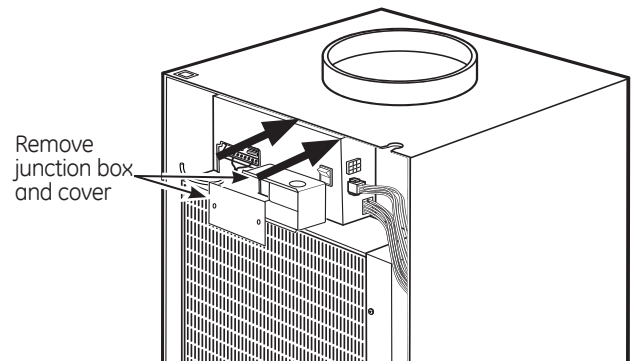

3. Connect the power cord, with a loop, through the strain relief.

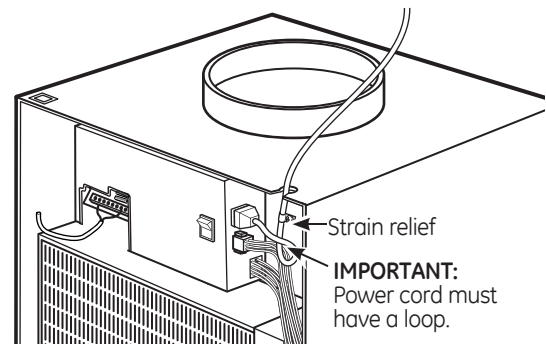

Installation Instructions

DIRECT CONNECT APPLICATIONS

FOR 230/208 VOLT DIRECT CONNECT APPLICATIONS ONLY

Direct connection to branch circuit wiring inside the provided junction box must be made by connecting as follows in steps 1–3 below.

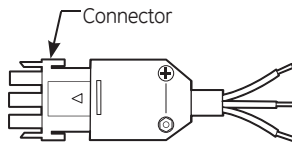

FOR 265 VOLT DIRECT CONNECT APPLICATIONS ONLY

IMPORTANT: Connection of a 265V AC product to a branch circuit **MUST** be done by direct connection in accordance with the National Electrical Code. Plugging this unit into a building mounted exposed receptacle is not permitted by code.

These models must be installed using the appropriate GE power supply kit for the branch circuit amperage and the electrical resistance heater wattage desired. See the POWER CONNECTION CHART on page 13 to select the appropriate kit.

It is the responsibility of the installer to ensure the connection of components is done in accordance with electrical codes.

Direct connection to branch circuit wiring inside the provided junction box must be made by connecting as follows in steps 1–3 below.

1 REMOVE JUNCTION BOX COVER

- Remove the junction box cover by taking out the front two screws.

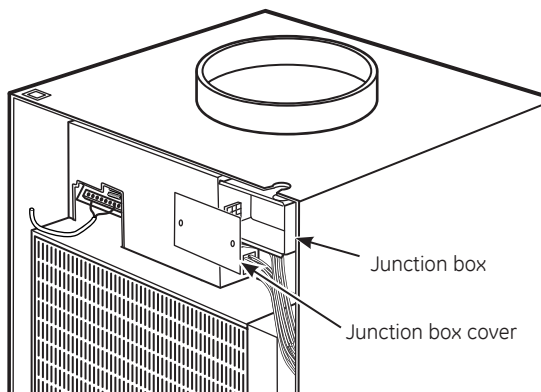

2 ATTACH CONDUIT

- Use the round knockout hole at the top of the junction box to install conduit coming from the branch circuit. Install and clamp the conduit through the conduit clamp and bring wire leads into the junction box. Leave 8" of wire free from the end of the conduit.

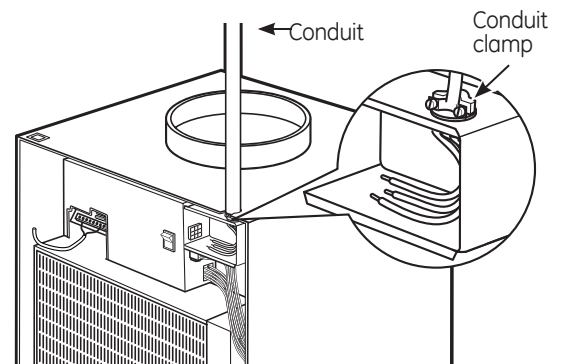

Installation Instructions

DIRECT CONNECT APPLICATIONS

3 MAKE WIRE LEAD CONNECTIONS INSIDE THE JUNCTION BOX

1. Make all wire connections by using appropriate UL-listed electrical connectors and techniques.
2. Select the applicable wiring situation and follow the instructions accordingly:
 - **1-Phase 220-240 VAC**
 When connecting the Zoneline to a single-phase circuit for 230V applications:
 Connect the white and black leads of the Zoneline power supply kit to the branch circuit L1 and L2 leads. (The white lead of the power supply kit should be identified by the installer using electrical tape with some color other than green or white.) Connect the green lead of the power supply kit to the power supply and branch circuit ground.
 - **3-Phase 208 VAC with "Crazy Leg"**
 When connecting the Zoneline to a three-phase circuit with "Crazy Leg" for 208V applications:
 Connect the white and black leads of the Zoneline power supply kit to the branch circuit Neutral and L1 leads. (The white lead of the power supply kit should be connected to neutral.) Connect the green lead of the power supply kit to the power supply and branch circuit ground.
 - **3-Phase 253-277 VAC**
 When connecting the Zoneline to a three-phase circuit for 265V applications:
 Connect the white and black leads of the Zoneline power supply kit to the branch circuit Neutral and L1 leads. (The white lead of the power supply kit should be connected to neutral.) Connect the green lead of the power supply kit to the power supply and branch circuit ground.
3. Be sure that all wire leads are inside the junction box and not pinched between the box and the unit. The green insulated ground wire from the Zoneline **MUST** be connected to the branch circuit ground wire.
4. Plug the 9-pin connector into the 9-pin receptacle in the junction box.
5. Replace the junction box cover by replacing the two screws removed earlier.

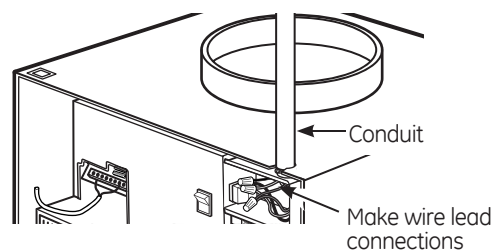

POWER CONNECTION CHART

Power Cord Connections

230/208 Volt Power Supply Kits	Wall Plug Configuration	Circuit Protective Device	Heater Wattage @ 230/208 Volts
RAK3152	Tandem Perpendicular Large Tandem	15-Amp Time-Delay Fuse or Breaker	2.55/2.09 KW
RAK3202		20-Amp Time-Delay Fuse or Breaker	3.45/2.82 KW
RAK3302		30-Amp Time-Delay Fuse or Breaker	5.00/4.10 KW

Direct Connections

230/208 Volt Power Supply Kits	Heater Wattage @ 230/208 Volts	Circuit Protective Device
RAK4157	2.55 KW/2.09 KW	15-Amp Time-Delay Fuse or Breaker
RAK4207	3.45 KW/2.82 KW	20-Amp Time-Delay Fuse or Breaker
RAK4307	5.00 KW/4.10 KW	30-Amp Time-Delay Fuse or Breaker

265 Volt Power Supply Kits	Heater Wattage @ 265 Volts	Circuit Protective Device
RAK5157	2.55 KW	15-Amp Time-Delay Fuse or Breaker
RAK5207	3.45 KW	20-Amp Time-Delay Fuse or Breaker
RAK5307	5.00 KW	30-Amp Time-Delay Fuse or Breaker

Installation Instructions

ZONELINE COMPONENTS

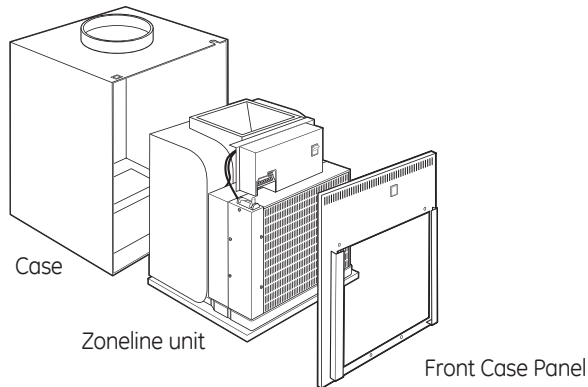

REQUIRED ACCESSORIES

(Check the "Essential Elements" label on the unit.)

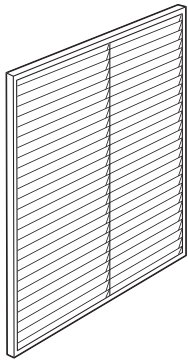

Architectural Louver
RAVAL1

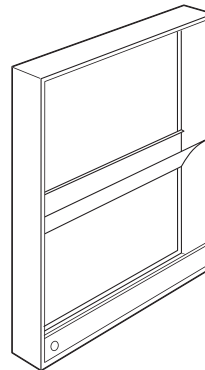

Cutout
Dimensions:
20" W x 32¼" H

Wall Plenum

- RAVWP6 - 6"D x 19¾"W x 32"H
- RAVWP8 - 8"D x 19¾"W x 32"H
- RAVWP12 - 12"D x 19¾"W x 32"H
- RAVWP15 - 15"D x 19¾"W x 32"H

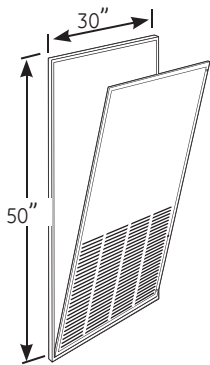

Cutout
Dimensions:
28"W x 48"H

Access Panel with
Return Air Grille
RAVRG1

OR

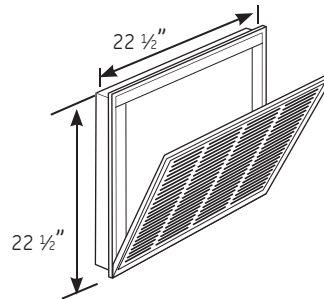

Cutout
Dimensions:
20⅝"W x 20⅝"H

Return Air Grille
RAVRG2

Wall Thermostat

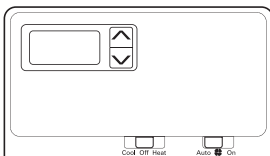

Model Type	Mechanical Thermostat	Electronic Thermostat
Heat/Cool Models	4-wire	5-wire
Heat Pump Models	6-wire	6-wire

Check the thermostat instructions for correct wiring and installation requirements.

Installation Instructions

TYPICAL UTILITY CLOSET AND DIMENSIONS (FOR REFERENCE ONLY)

UNIT INSTALLED THROUGH FRONT OF CASE

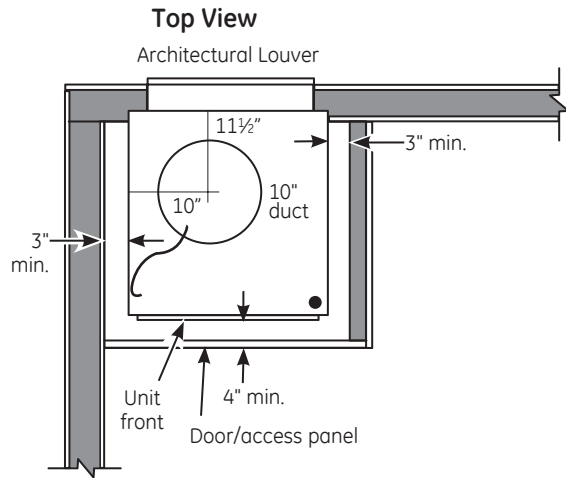

UNIT INSTALLED THROUGH SIDE OF CASE

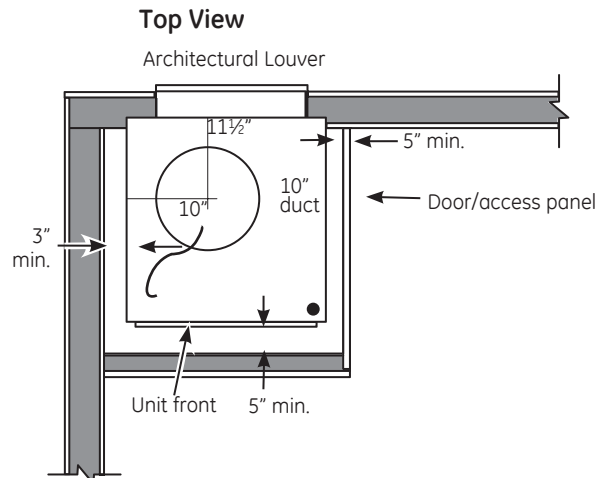

Side View

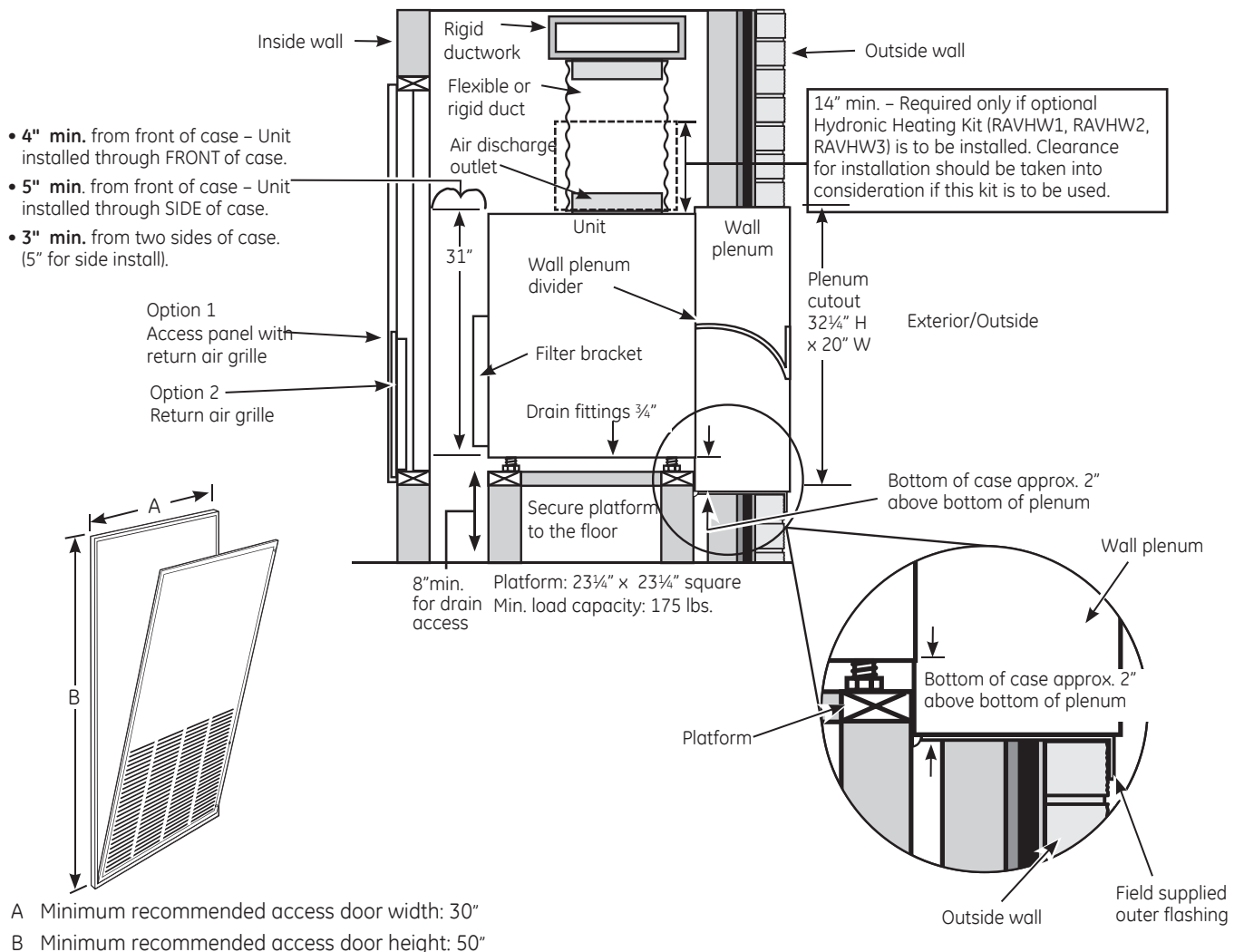

Installation Instructions

UTILITY CLOSET CONNECTION LOCATIONS

IMPORTANT: Plan and locate plenum, wall plug, drains and thermostat carefully to avoid interference. Hard-to-reach locations will make installation and service difficult!

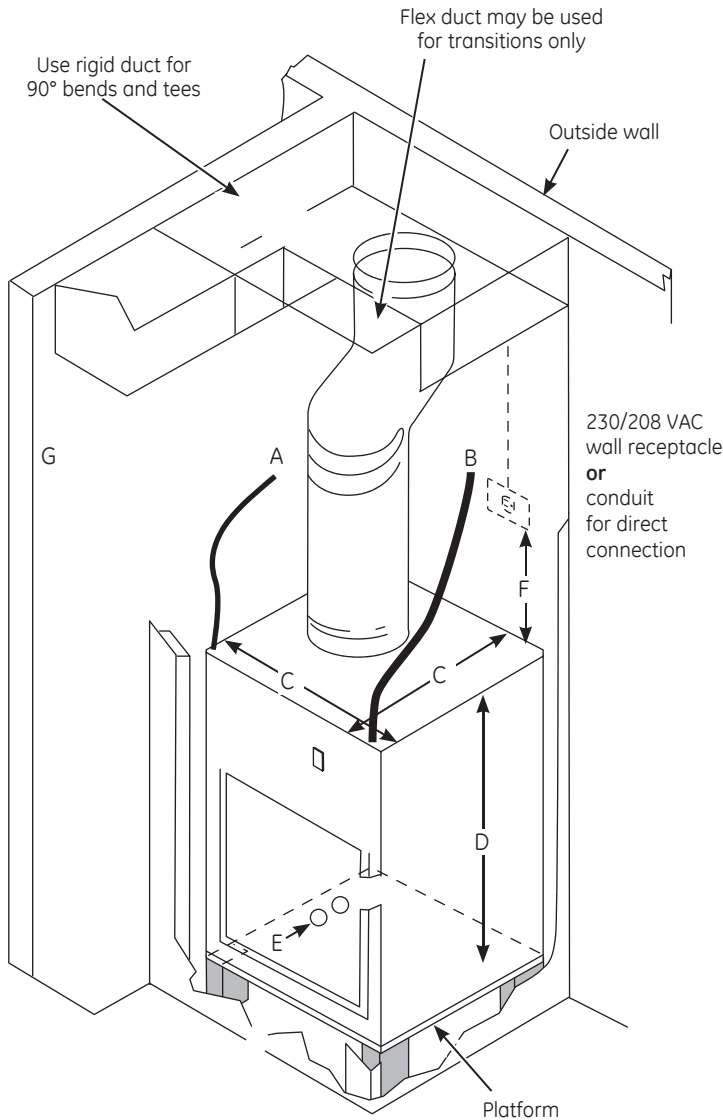

Reference Dimensions

- A Thermostat cable: 9½" long
- B Power cord: 60" long
- C Case width and depth: 23⅛"
- D Case height: 31"
- E Condensate drains: 3/4" connector
 - Primary Drain – Centerline of cutout is approximately 5¼" from left case wall and 8½" from back case wall.
 - Secondary Drain – Centerline of cutout is approximately 6½" from left case wall and 5¼" from back case wall.
- F Typical wall plug: 6"–12" above case
- G Room air sensor kit: 10' long

Installation Instructions

RETURN AIR GRILLE INSTALLATION OPTIONS

The room return air grille may be installed toward the front or either side of the unit. Improper return air arrangements will cause performance problems.

There are three indoor return air grille installation options. Choose the option that best suits your installation requirements. Follow the Installation Instructions provided with the return air grille accessory for installation details.

NOTE: Use only one filter in the installation. The filter may be installed on the unit or in the access panel/door.

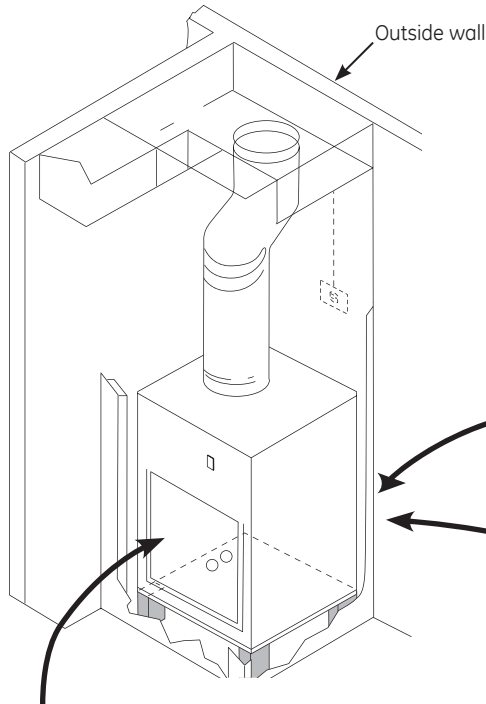

RAVRG1 – Access panel with return air grille

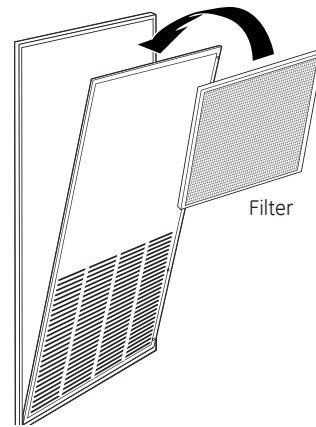

Option 1

Unit-mounted filter with a field-supplied return air grille and access door/panel

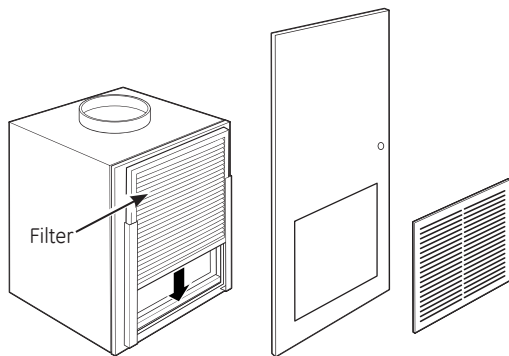

Option 3

RAVRG2 – Return air grille

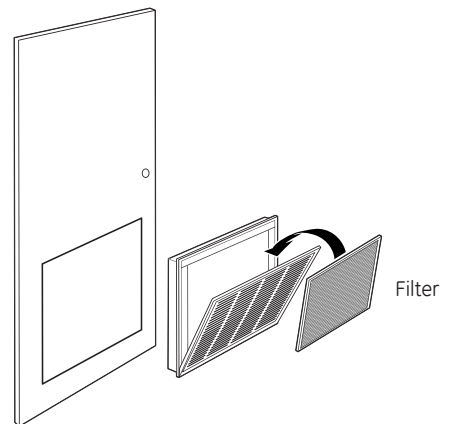

Option 2

Installation Instructions

WALL PLENUM AND ARCHITECTURAL LOUVER INSTALLATION

- Install the appropriate wall plenum through the exterior wall in accordance with the Installation Instructions provided with the plenum.

IMPORTANT: The wall plenum is not designed to carry structural loads. Proper wall header construction is required. The plenum requires proper flashing, shim and caulk for a weather resistant installation.

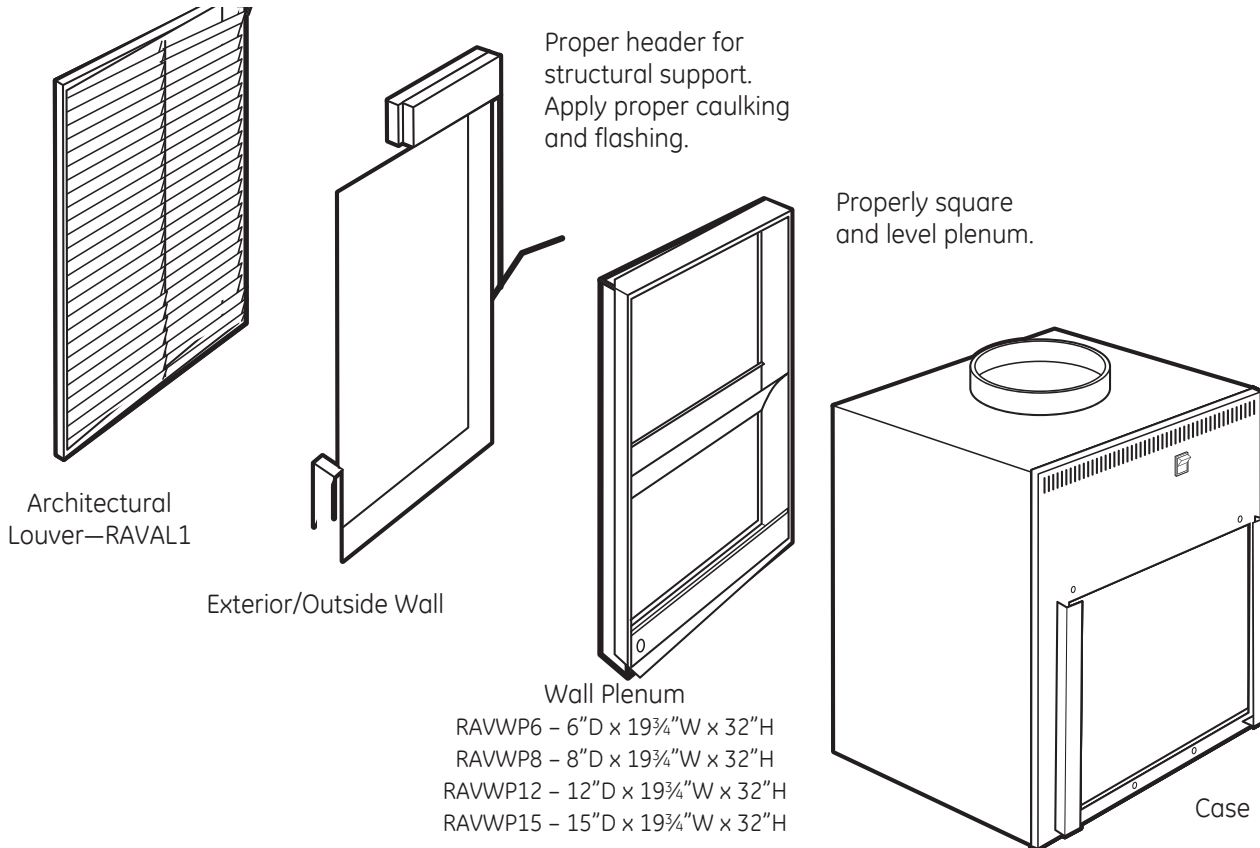

1 BUILD AND INSTALL THE ZONELINE BASE PLATFORM

1. Construct a 23 $\frac{3}{4}$ " min. x 23 $\frac{3}{4}$ " min. square platform with legs to raise the platform a minimum of 8".

NOTE: The platform must have a load-bearing capacity of 175 lbs. minimum.

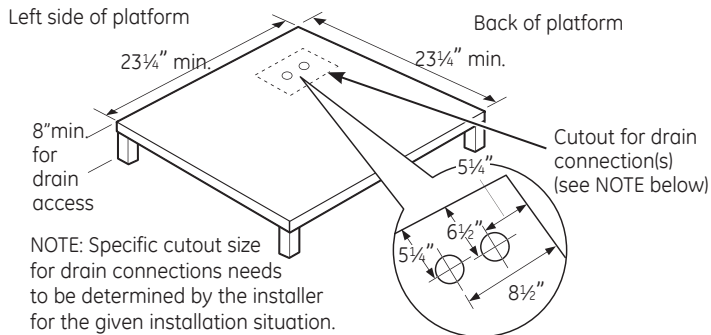

NOTE: Specific cutout size for drain connections needs to be determined by the installer for the given installation situation.

2. Make drain hole cutout(s):
 - Primary Drain – Centerline of drain is approximately 5 $\frac{1}{4}$ " from left platform edge and 8 $\frac{1}{2}$ " from back platform edge.
 - Secondary Drain – Centerline of drain is approximately 6 $\frac{1}{2}$ " from left platform edge and 5 $\frac{1}{4}$ " from back platform edge.
3. Place the platform in the utility closet with the following clearance between it and the interior surface of the walls/door/panel:
 - 4" min. from front of the case – Unit to be installed through **FRONT** of case
 - 5" min. from front of the case – Unit to be installed through **SIDE** of case
 - 3" min. from two sides of the case (5" for side installation).
4. Align the platform with the opening of the wall plenum and secure to the floor using appropriate brackets and bolts.

Installation Instructions

2 INSTALL THE DRAIN(S)

An external or an internal drain must be attached to the primary drain connector. A secondary drain is supplied if required by state and local codes. Refer to the local codes for proper installation of the drains. If the secondary drain is not used, seal its drain port with a 3/4" MNPT plug.

External Drain

Attach a 90° PVC elbow to the unit's female 3/4" NPT drain connector. Use the other end of the elbow to run a 3/4" Sch. 40 PVC pipe through the knockout holes of both the wall plenum and the architectural louver to the outside. Seal the gap between the plenum hole and PVC tube. See the Installation Instructions in the RAVAL1.

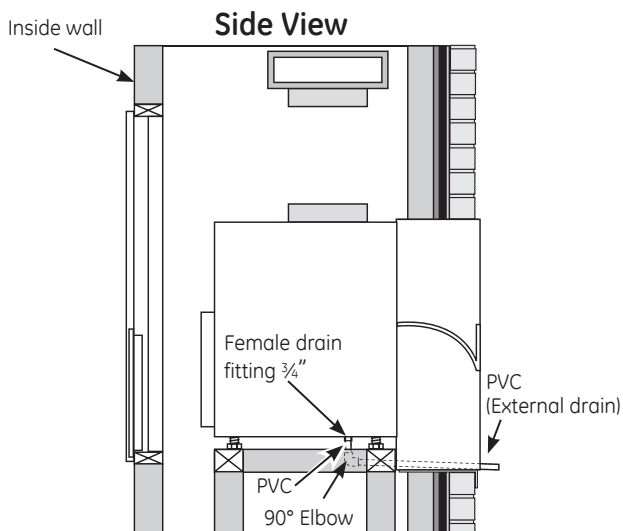

Internal Drain

Attach PVC to the unit's female 3/4" NPT drain connector. See the Installation Instructions in the RAVAL1. Local codes may apply.

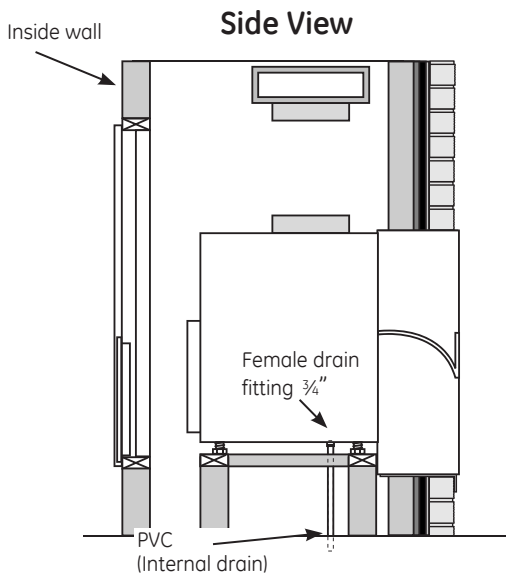

3 DUCTWORK

Prepare the closet ductwork for later connection to the case.

The total flow rate (CFM) and external static pressure (ESP) available can be estimated from the chart below. Use these charts to select your fan speed setting. The collar on top of the case accepts standard 10" duct.

Pull all duct tight. Extra duct slack can greatly increase static pressure.

NOTICE: Flex duct can collapse and cause airflow restrictions. Do not use flex duct for 90° bends or unsupported runs of 5 ft. or more.

Airflow - CFM @ 230 Volts and @ 265 Volts					
		Indoor Fan CFM			
		DUCT SELECT SWITCH			
		UP		DOWN	
	ESP (in. water)	High CFM	Medium CFM	Medium CFM	Low CFM
AZ85(H/E)09	0.0	520	460	460	360
	0.1	500	415	415	290
	0.2	480	370	370	220
	0.3	440	265	265	-
	0.4	400	160	160	-
AZ85(H/E)12	0.0	590	500	500	380
	0.1	570	465	465	325
	0.2	550	430	430	270
	0.3	480	345	345	-
	0.4	410	260	260	-
AZ85(H/E)18	0.0	600	520	520	400
	0.1	585	485	485	340
	0.2	570	450	450	280
	0.3	510	375	375	-
	0.4	450	300	300	-

To correct for 208 volts: 0.91

Your airflow should be balanced based on many factors, such as available ESP, room CFM, and ductwork. Consult an HVAC engineer for proper applications. External static pressure (ESP) can be measured with a manometer or pitot tube. Once this ESP is established, you can calculate the CFM using the above chart.

CFM Recommendations

9,000 BTU		12,000 BTU			18,000 BTU			
390	415	440	440	465	490	435	485	535
	•			•			•	

• = Recommended Mid Range

Higher CFMs tend to increase Sensible capacity, enhance room circulation and increase duct noise, while lower CFMs tend to increase Latent capacity and reduce noise.

Installation Instructions

4 INSTALL AND CONNECT THE CASE

1. Remove the front case panel and pull the unit out of the case. Place the empty case onto the platform in the closet with the outdoor side facing the wall plenum opening. Align the case with plenum opening and attach with six field-supplied sheet metal screws (corrosion-resistant screws recommended).
2. Adjust all four leveling legs until the case is level.

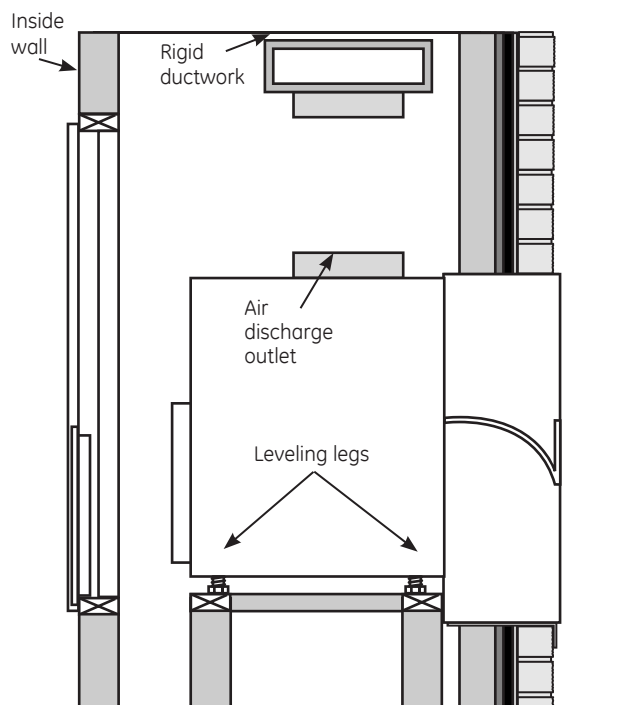

3. Using field-supplied screws, bolt the case to the platform.
4. Connect the internal or external drain(s) as necessary.

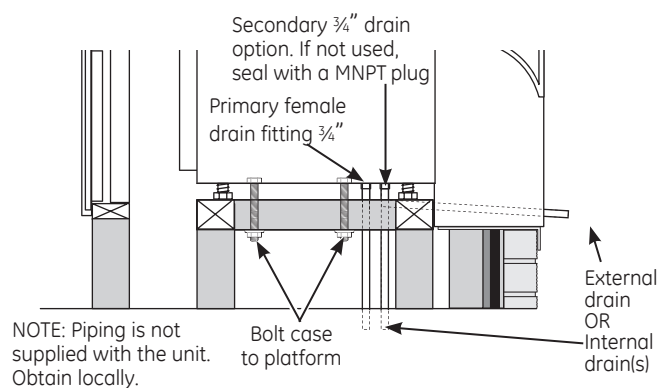

5a INSTALL AND GROUND THE UNIT TO THE CASE UNIT INSTALLED THROUGH FRONT OF CASE

1. Slide the back of the unit into the case. Push the unit all of the way into the case until it stops.

NOTE: Either of the case sides may be removed to enable the unit to be slid into the case.

2. Ground the unit to the case by installing the front case-to-unit hex-bolt and discard the two case-to-unit side screw.

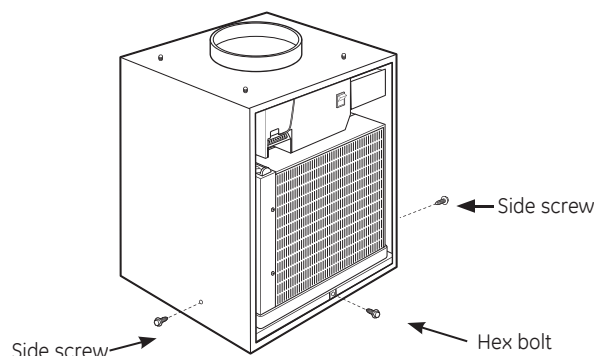

5b INSTALL AND GROUND THE UNIT TO THE CASE UNIT INSTALLED THROUGH SIDE OF CASE

1. Slide the side of the unit into the case. Push the unit all of the way into the case until it stops.

NOTE: Either of the case sides may be removed to enable the unit to be slid into the case.

2. Attach the case side panel to the main case.
3. Ground the unit to the case by installing the front unit-to-case hex-bolt and discard the two case-to-unit side screw.

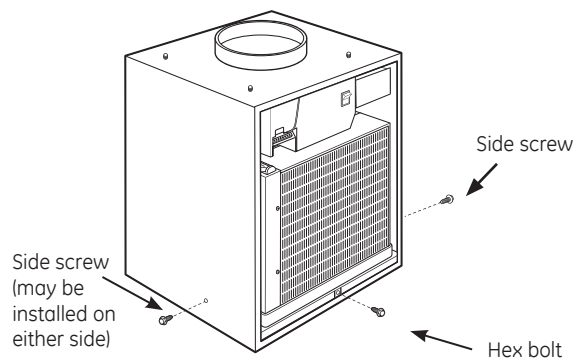

Installation Instructions

6 MAKE UNIT ELECTRICAL CONNECTIONS

1. Connect the thermostat wires to the unit and set the dip switches to the appropriate settings.

NOTE: See the *Controls-Terminal Connections* and *Controls-Dip Switches* sections of this manual and the manual with the separate thermostat for proper connections and settings.

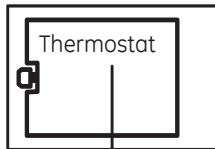

Maximum Wiring Length for Thermostat Connection to the Unit

66 ft. for AWG 18
60 ft. for AWG 20
40 ft. for AWG 24
AWG - American Wire Gauge

Unit Connections

2. Make power connections to the unit.
NOTE: See the *ELECTRICAL REQUIREMENTS* and *DIRECT CONNECT APPLICATIONS* sections, as appropriate, of this manual for proper connections.
3. Replace the case front panel by replacing the four front screws and the two top screws.

7 CONNECT THE TOP DUCT

1. Install the duct onto the air discharge outlet.

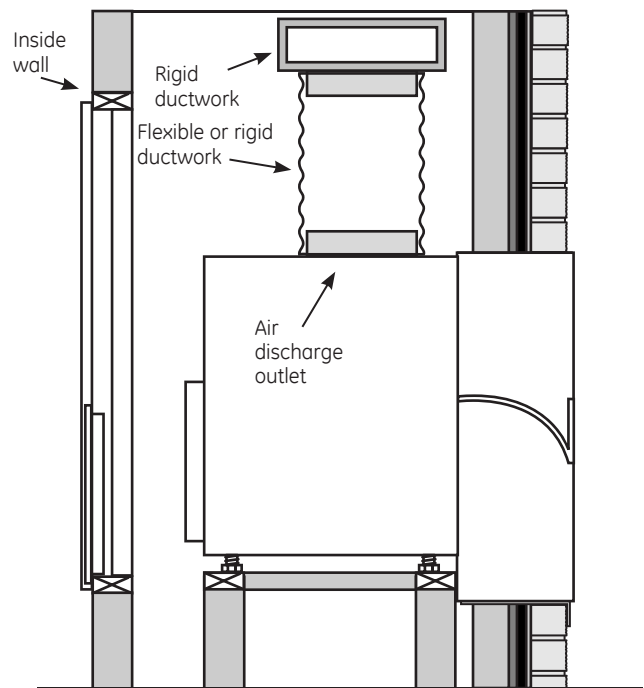

2. Secure the top duct to the unit by turning the four case top duct adjusting screws until they are tight. Use a field supplied clamp to lock the top duct to the case.

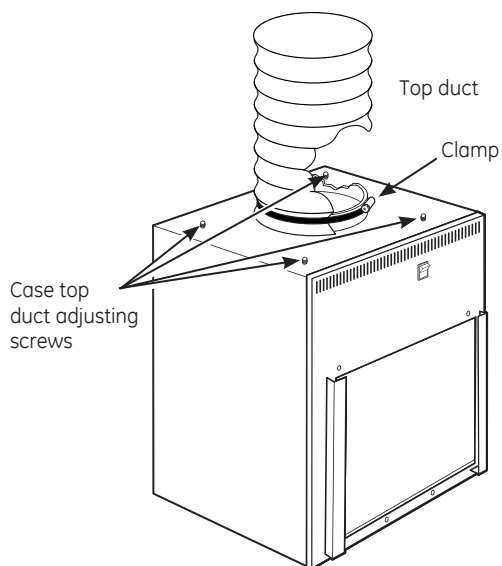

Installation Instructions

8 FINAL CHECK

Review this Checklist before restoring power.

- Correct line voltage?
- Single circuit only?
- HVACR type breaker/fuse?
- Ductwork connected?
- Case and unit level?
- Wall plenum caulked? Level? Flashing?
- Drain connected?
- Wall thermostat wired correctly?
- Unit wired correctly?
- Hydronic plumbing connections (if applicable)
- Hydronic wiring connections (if applicable)

9 CONNECT POWER

1. If all the above items are correct, turn the power on at the main service panel.
2. Turn the unit power switch, on the front of the unit, to ON by pressing the top of the switch in.

SERVICING

⚠ WARNING: Risk of Electric Shock, can cause injury or death. Before servicing, switch power off at the service panel and lock the area to prevent power from being switched on accidentally. When the area cannot be locked, securely fasten a prominent warning device, such as a tag, to the service panel.

NOTE: We strongly recommend that any servicing be performed by a qualified individual.

For ease of service, the unit can be removed from the case:

1. Remove the front case panel.
2. Unplug the power cord and disconnect the wall thermostat connections.
3. Raise the top duct by turning all four case top duct adjusting screws counterclockwise.
4. Remove the front and/or side case-to-unit grounding screw, if present.
5. Slide the unit out of the case.

Troubleshooting Tips

Problem	Possible Causes	What To Do
Zonline does not start	The unit is unplugged.	<ul style="list-style-type: none"> Make sure the Zonline plug is pushed completely into the outlet.
	The fuse is blown/circuit breaker is tripped.	<ul style="list-style-type: none"> Check the house fuse/circuit breaker box and replace the fuse or reset the breaker.
	The unit is waiting for the compressor overload protector to reset.	<ul style="list-style-type: none"> This is normal. The Zonline will start again after it resets.
	Power failure.	<ul style="list-style-type: none"> There is a protective time delay (up to 3 minutes) to prevent tripping of the compressor overload. For this reason, the unit may not start normal heating or cooling for 3 minutes after it is turned back on.
Zonline does not cool or heat as it should	Indoor airflow is restricted.	<ul style="list-style-type: none"> Make sure there are no curtains, blinds or furniture blocking the air discharge grille or the return air grille.
	Outdoor airflow is restricted or recirculated.	<ul style="list-style-type: none"> Make sure the architectural louver is not restricted. This can cause the unit to cycle off due to the compressor overload. Outdoor grille must have a minimum of 65% free area. Non-GE grilles may be too restrictive for proper performance. Consult your salesperson for assistance.
	The air filter is dirty.	<ul style="list-style-type: none"> Change the filter at least every 30 days. See the Care and Cleaning–Air Filters section.
	The room may have been hot or cold.	<ul style="list-style-type: none"> When the Zonline is first turned on you need to allow time for the room to cool down or warm up.
	Outdoor air is entering the room.	<ul style="list-style-type: none"> Set the vent control to the CLOSE position.
Burning odor at the start of heating operation	Dust is on the surface of the heating element.	<ul style="list-style-type: none"> This can cause a “burning” odor at the beginning of the heating operation. This odor should quickly fade.
The air is not always cool or hot during operation	The heat pump is not producing hot air.	<ul style="list-style-type: none"> This is normal. The heat pump will produce warm air but not as hot as air produced when the higher-cost electric heat is used.
	The fan switch may be set at continuous fan.	<ul style="list-style-type: none"> This causes the fan to blow room temperature air even when the compressor or heater cycles off. The continuous air movement provides better overall temperature control.
The air does not feel warm enough during heating operation	The heat pump alone produces air that feels cooler than desired.	<ul style="list-style-type: none"> Use the Electric Heat Option. This turns off the heat pump and warms with electric heat only. NOTE: Use of this option will result in increased energy consumption.

Safety Instructions

Operating Instructions

Care and Cleaning

Troubleshooting Tips

Consumer Support

Things that are normal.

Normal Operating Sounds

PING!

You may hear a pinging noise caused by water being picked up and thrown against the condenser on rainy days or when the humidity is high. This design feature helps remove moisture and improve efficiency.

“CLICK”

You may hear relays click when the controls cycle on and off or are adjusted to change the room temperature.

DRIP

Water will collect in the base pan during high humidity or on rainy days. The water may overflow and drip from the outdoor side of the unit.

WHIR!

The indoor fan runs continuously when the unit is operating in the cooling mode, unless the fan switch behind the case front panel is set at fan cycle (up). This will cause the fan to cycle on and off with the compressor. You may also hear a fan noise stop and start.

**3-Minute
Delay**



You may notice a few minutes delay in starting if you try to restart the Zoneline too soon after turning it off or if you adjust the thermostat right after the compressor has shut off. This is due to a built-in restart protector for the compressor that causes a 3-minute delay.

SILENCE

During the defrost cycle, both indoor and outdoor fans stop and the compressor will operate in the cooling mode to remove frost from the outdoor coil. After defrost, the unit will restart in electric heat to quickly warm the room to the desired comfort level.

**COMPRESSOR
PROTECTION**

To protect the compressor and prevent short cycling, the unit is designed to run for a minimum of 3 minutes after the compressor starts at any thermostat setting.

Safety Instructions
Operating Instructions
Care and Cleaning
Troubleshooting Tips
Consumer Support

Consumer Support	Troubleshooting Tips	Care and Cleaning	Operating Instructions	Safety Instructions
------------------	----------------------	-------------------	------------------------	---------------------

Notes.

Vertical Zoneline Warranty.

All warranty service provided by our Factory Service Centers, or an authorized Customer Care® technician. To schedule service, on-line, visit us at GEAppliances.com, or call 800.GE.CARES (800.432.2737). For service in Canada, contact Gordon Williams Corp. at 1.888.209.0999. Please have serial number and model number available when calling for service.

Staple your receipt here.
Proof of the original purchase date is needed to obtain service under the warranty.

For The Period Of:	GE Will Replace:
One Year From the date of the original purchase	Any part of the Zoneline which fails due to a defect in materials or workmanship. During this limited one-year warranty , GE will also provide, free of charge , all labor and related service to replace the defective part.
Five Years From the date of the original purchase	Any part of the sealed refrigerating system (the compressor, condenser, evaporator and all connecting tubing) which fails due to a defect in materials or workmanship. During this four-year limited additional warranty , GE will also provide, free of charge , all labor and related service to replace the defective part.
Five Years From the date of the original purchase	For the second through the fifth year from the date of original purchase, GE will replace certain parts that fail due to a defect in materials or workmanship. Parts covered are fan motors, switches, thermostats, electric resistance heater, electric resistance heater protectors, compressor overload, solenoids, circuit boards, auxiliary controls, thermistors, frost controls, ICR pump, capacitors, varistors and indoor blower bearing. During this four-year limited additional warranty , you will be responsible for any labor or on-site service costs.

What GE Will Not Cover:

- Service trips to your site to teach you how to use the product.
- Improper installation, delivery or maintenance.
If you have an installation problem, or if the air conditioner is of improper cooling or heating capacity for the intended use, contact your dealer or installer. You are responsible for providing adequate electrical connecting facilities.
- In commercial locations, labor necessary to move the unit to a location where it is accessible for service by an individual technician.
- Failure or damage resulting from corrosion due to installation in an environment containing corrosive chemicals.
- Replacement of fuses or resetting of circuit breakers.
- Filters.
- Failure of the product resulting from modifications to the product or due to unreasonable use including failure to provide reasonable and necessary maintenance.
- Failure or damage resulting from corrosion due to installation in a coastal environment, except for models treated with special factory-applied anti-corrosion protection as designated in the model number.
- Damage to product caused by improper power supply voltage, accident, fire, floods or acts of God.
- Incidental or consequential damage caused by possible defects with this air conditioner.
- Damage caused after delivery.
- Product not accessible to provide required service.

EXCLUSION OF IMPLIED WARRANTIES—Your sole and exclusive remedy is product repair as provided in this Limited Warranty. Any implied warranties, including the implied warranties of merchantability or fitness for a particular purpose, are limited to one year or the shortest period allowed by law.

This warranty is extended to the original purchaser and any succeeding owner for products purchased for use within the USA and Canada. If the product is located in an area where service by a GE Authorized Servicer is not available, you may be responsible for a trip charge or you may be required to bring the product to an Authorized GE Service location for service. In Alaska, the warranty excludes the cost of shipping or service calls to your site.

Some states or provinces do not allow the exclusion or limitation of incidental or consequential damages. This warranty gives you specific legal rights, and you may also have other rights which vary from state to state or province to province. To know what your legal rights are, consult your local, state or provincial consumer affairs office or your state's Attorney General.

Warrantor: General Electric Company, Louisville, KY 40225

Consumer Support.



GE Appliances Website

GEAppliances.com

Have a question or need assistance with your appliance? Try the GE Appliances Website 24 hours a day, any day of the year! For greater convenience and faster service, you can now download Owner's Manuals, order parts or even schedule service on-line.

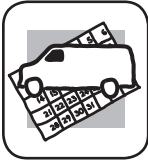

Schedule Service

GEAppliances.com

Expert GE repair service is only one step away from your door. Get on-line and schedule your service at your convenience any day of the year! Or call 800.GE.CARES (800.432.2737) during normal business hours. For service in Canada, contact Gordon Williams Corp. at 1.888.209.0999.



Real Life Design Studio

GEAppliances.com

GE supports the Universal Design concept—products, services and environments that can be used by people of all ages, sizes and capabilities. We recognize the need to design for a wide range of physical and mental abilities and impairments. For details of GE's Universal Design applications, including kitchen design ideas for people with disabilities, check out our Website today. For the hearing impaired, please call 800.TDD.GEAC (800.833.4322).

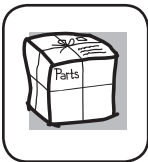

Parts and Accessories

GEAppliances.com

Individuals qualified to service their own appliances can have parts or accessories sent directly to their homes (VISA, MasterCard and Discover cards are accepted). Order on-line today, 24 hours every day or by phone at 800.626.2002 during normal business hours.

Instructions contained in this manual cover procedures to be performed by any user. Other servicing generally should be referred to qualified service personnel. Caution must be exercised, since improper servicing may cause unsafe operation.



Contact Us

GEAppliances.com

If you are not satisfied with the service you receive from GE, contact us on our Website with all the details including your phone number, or write to:

General Manager, Customer Relations
GE Appliances, Appliance Park
Louisville, KY 40225



Register Your Appliance

GEAppliances.com

Register your new appliance on-line—at your convenience! Timely product registration will allow for enhanced communication and prompt service under the terms of your warranty, should the need arise. You may also mail in the pre-printed registration card included in the packing material.

Free Manuals Download Website

<http://myh66.com>

<http://usermanuals.us>

<http://www.somanuals.com>

<http://www.4manuals.cc>

<http://www.manual-lib.com>

<http://www.404manual.com>

<http://www.luxmanual.com>

<http://aubethermostatmanual.com>

Golf course search by state

<http://golfingnear.com>

Email search by domain

<http://emailbydomain.com>

Auto manuals search

<http://auto.somanuals.com>

TV manuals search

<http://tv.somanuals.com>