

2-9827



Digital Answer-Phone™ User's Guide



To	Press
Play message	1
Repeat message	8
(during playback)	
Play previous message	7
(during playback)	
Stop	3
(during playback)	
Erase message	0
(during playback)	
Skip message	9
(during playback)	
Turn answer OFF	5
Turn answer ON	6
Record outgoing announcement	8
(Start recording after the beep)	
Leave a message	7
Play outgoing announcement	2
If unit answers on 10th ring:	
Answerer is off — Enter security code to automatically turn on answerer.	
- or -	
Memory is full — Enter security code; listen to messages; reset answerer.	

To	Press
Play message	1
Repeat message	8
(during playback)	
Play previous message	7
(during playback)	
Stop	3
(during playback)	
Erase message	0
(during playback)	
Skip message	9
(during playback)	
Turn answer OFF	5
Turn answer ON	6
Record outgoing announcement	8
(Start recording after the beep)	
Leave a message	7
Play outgoing announcement	2
If unit answers on 10th ring:	
Answerer is off — Enter security code to automatically turn on answerer.	
- or -	
Memory is full — Enter security code; listen to messages; reset answerer.	

To	Press
Play message	1
Repeat message	8
(during playback)	
Play previous message	7
(during playback)	
Stop	3
(during playback)	
Erase message	0
(during playback)	
Skip message	9
(during playback)	
Turn answer OFF	5
Turn answer ON	6
Record outgoing announcement	8
(Start recording after the beep)	
Leave a message	7
Play outgoing announcement	2
If unit answers on 10th ring:	
Answerer is off — Enter security code to automatically turn on answerer.	
- or -	
Memory is full — Enter security code; listen to messages; reset answerer.	

To	Press
Play message	1
Repeat message	8
(during playback)	
Play previous message	7
(during playback)	
Stop	3
(during playback)	
Erase message	0
(during playback)	
Skip message	9
(during playback)	
Turn answer OFF	5
Turn answer ON	6
Record outgoing announcement	8
(Start recording after the beep)	
Leave a message	7
Play outgoing announcement	2
If unit answers on 10th ring:	
Answerer is off — Enter security code to automatically turn on answerer.	
- or -	
Memory is full — Enter security code; listen to messages; reset answerer.	

FCC REGISTRATION INFORMATION

Your GE telephone equipment is registered with the Federal Communications Commission and is in compliance with parts 15 and 68, FCC Rules and Regulations.

1 Notification to the Local Telephone Company

On the bottom of this equipment is a label indicating, among other information, the FCC Registration number and Ringer Equivalence Number (REN) for the equipment. You must, upon request, provide this information to your telephone company.

The REN is useful in determining the number of devices you may connect to your telephone line and still have all of these devices ring when your telephone number is called. In most (but not all) areas, the sum of the RENs of all devices connected to one line should not exceed 5. To be certain of the number of devices you may connect to your line as determined by the REN, you should contact your local telephone company.

Notes

- This equipment may not be used on coin service provided by the telephone company.
- Party lines are subject to state tariffs, and therefore, you may not be able to use your own telephone equipment if you are on a party line. Check with your local telephone company.
- Notice must be given to the telephone company upon permanent disconnection of your telephone from your line.

2 Rights of the Telephone Company

Should your equipment cause trouble on your line which may harm the telephone network, the telephone company shall, where practicable, notify you that temporary discontinuance of service may be required. Where prior notice is not practicable and the circumstances warrant such action, the telephone company may temporarily discontinue service immediately. In case of such temporary discontinuance, the telephone company must: (1) promptly notify you of such temporary discontinuance; (2) afford you the opportunity to correct the situation; and (3) inform you of your right to bring a complaint to the Commission pursuant to procedures set forth in Subpart E of Part 68, FCC Rules and Regulations.

The telephone company may make changes in its communications facilities, equipment, operations of procedures where such action is required in the operation of its business and not inconsistent with FCC Rules and Regulations. If these changes are expected to affect the use or performance of your telephone equipment, the telephone company must give you adequate notice, in writing, to allow you to maintain uninterrupted service.

INTERFERENCE INFORMATION

This device complies with Part 15 of the FCC Rules. Operation is subject to the following two conditions: (1) This device may not cause harmful interference; and (2) This device must accept any interference received, including interference that may cause undesired operation.

This equipment has been tested and found to comply with the limits for a Class B digital device, pursuant to Part 15 of the FCC Rules. These limits are designed to provide reasonable protection against harmful interference in a residential installation.

This equipment generates, uses, and can radiate radio frequency energy and, if not installed and used in accordance with the instructions, may cause harmful interference to radio communications. However, there is no guarantee that interference will not occur in a particular installation.

If this equipment does cause harmful interference to radio or television reception, which can be determined by turning the equipment off and on, the user is encouraged to try to correct the interference by one or more of the following measures:

- Reorient or relocate the receiving antenna (that is, the antenna for radio or television that is "receiving" the interference).
- Reorient or relocate and increase the separation between the telecommunications equipment and receiving antenna.
- Connect the telecommunications equipment into an outlet on a circuit different from that to which the receiving antenna is connected.
- Consult the dealer or an experienced radio/TV technician for help.

If these measures do not eliminate the interference, please consult your dealer or an experienced radio/television technician for additional suggestions. Also, the Federal Communications Commission has prepared a helpful booklet, "How To Identify and Resolve Radio/TV Interference Problems." This booklet is available from the U.S. Government Printing Office, Washington, D.C. 20402. Please specify stock number 004-000-00345-4 when ordering copies.

HEARING AID COMPATIBILITY

This telephone system meets FCC standards for Hearing Aid Compatibility.

FCC NUMBER IS LOCATED ON THE CABINET BOTTOM REN NUMBER IS LOCATED ON THE CABINET BOTTOM
--



INTRODUCTION

Your GE Digital Answer-Phone™ is designed to give you flexibility in use, and high quality performance. To get the most from your new telephone, we suggest that you take a few minutes right now to read through this instruction manual. If you have any questions or problems, consult the Table of Contents, the Troubleshooting Guide, or the Index for the solution.

TABLE OF CONTENTS

INSTALLATION AND SETUP	2
BEFORE YOU BEGIN	2
BATTERY INSTALLATION	3
TABLETOP INSTALLATION	4
WALL MOUNT INSTALLATION	5
BATTERY LOW INDICATOR	7
ANSWERING MACHINE SETUP	7
RECORDING THE OUTGOING ANNOUNCEMENT	8
TELEPHONE OPERATION	9
FLASH BUTTON	9
REDIAL BUTTON	10
TEMPORARY TONE FEATURE	10
MEMORY DIALING	11
STORING A NUMBER IN MEMORY	11
DIALING A NUMBER FROM MEMORY	12
ANSWERING MACHINE OPERATION	13
MESSAGE PLAYBACK	13
ERASING MESSAGES DURING MESSAGE PLAYBACK	13
LEAVING A MEMO	14
CALL SCREENING/AUTO DISCONNECT	14
TOLL SAVER FEATURE	15
ACCESSING THE ANSWERER FROM ANOTHER LOCATION	15
TROUBLESHOOTING TIPS	16
CARE AND MAINTENANCE	18
SERVICE	18
INDEX	19
LIMITED WARRANTY	20

WARNING: TO PREVENT FIRE OR ELECTRICAL SHOCK HAZARD, DO NOT EXPOSE THIS PRODUCT TO RAIN OR MOISTURE.

 THE LIGHTNING FLASH AND ARROW-HEAD WITHIN THE TRIANGLE IS A WARNING SIGN ALERTING YOU OF "DANGEROUS VOLTAGE" INSIDE THE PRODUCT.	CAUTION RISK OF ELECTRIC SHOCK DO NOT OPEN CAUTION: TO REDUCE THE RISK OF ELECTRIC SHOCK, DO NOT REMOVE COVER (OR BACK). NO USER-SERVICEABLE PARTS INSIDE. REFER SERVICING TO QUALIFIED SERVICE PERSONNEL.	 THE EXCLAMATION POINT WITHIN THE TRIANGLE IS A WARNING SIGN ALERTING YOU OF IMPORTANT INSTRUCTIONS ACCOMPANYING THE PRODUCT.
SEE MARKING ON BOTTOM / BACK OF PRODUCT		

PARTS CHECKLIST

Your package should contain the following items:

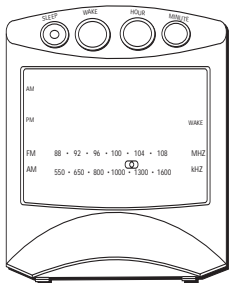

Base unit



Handset

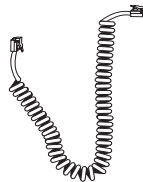

Long handset cord



Phone line cord

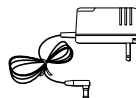

AC power adapter

INSTALLATION AND SETUP

Your GE Digital Answer-Phone™ can be mounted on the wall or placed on a counter top or table top. After you decide which type of installation you want, refer to the appropriate installation diagram.

BEFORE YOU BEGIN

MODULAR JACK REQUIREMENTS

You need a USOC: RJ11C type modular jack, similar to the one pictured here. If you don't have a modular jack, call your phone company to find out how to get one installed.

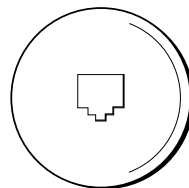

BATTERY INSTALLATION

In the event of a power loss, the 9-volt battery backup enables the answerer to retain messages stored in memory, the outgoing announcement, and time/day information.

1. Open the battery compartment door with a flat tool.
2. Insert a 9V battery (not included), as shown on the diagram inside the battery compartment.
3. Close the battery compartment door.

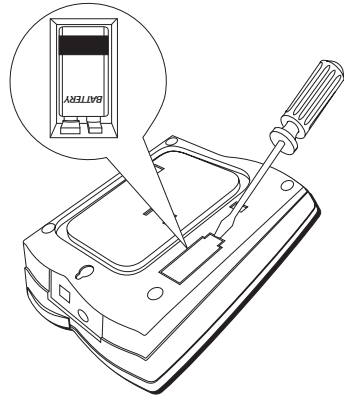

NOTE: When the battery needs to be replaced, the BATT. LOW indicator will flash.

BATTERY SAFETY PRECAUTIONS

For your safety, please follow these precautions:

- Do not recharge, disassemble, mutilate, wet, or dispose of batteries in fire.
- Keep batteries out of reach of children.
- Replace with 9V battery only (not included).
- When replacing batteries, be sure to unplug the phone line from the unit before inserting the batteries.

TABLETOP INSTALLATION

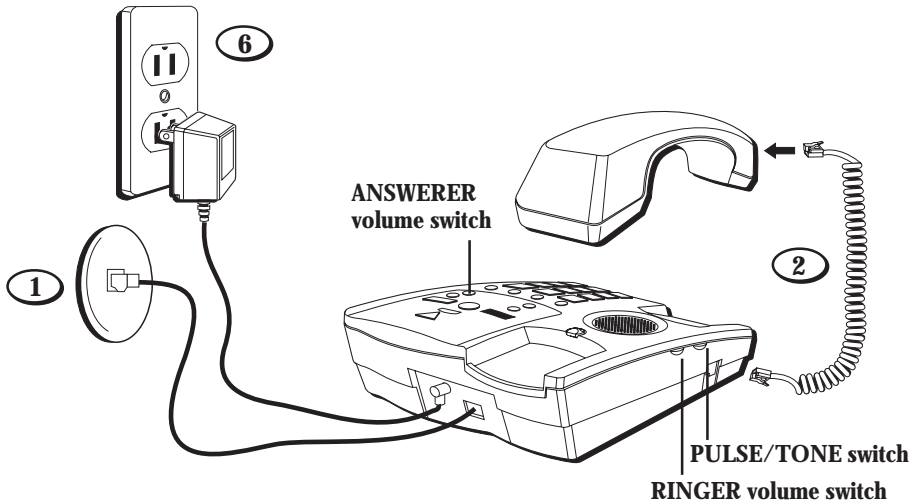

1. Plug the telephone line cord into PHONE LINE jack on the back of the unit and the other end into a modular jack RJ11C .
2. Plug the handset cord into the handset and into the telephone jack on the left side of the unit.
3. Set the PULSE/TONE switch on the left side of the phone to TONE if you use touch-tone service; set it to PULSE if you have rotary service.
4. Adjust the RINGER volume switch on the left side of the phone to the desired setting (the phone will only ring with the ringer set to LO or HI).
5. Adjust the ANSWERER volume switch on the right side of the phone to the desired setting.
6. Plug the AC power adapter into the phone and into an AC outlet.

NOTE: Only use the Thomson 5-2399 AC adapter that came with this unit. Using other adapters may damage the unit.

NOTE: Make sure that you have inserted the battery before installing the phone. If you have not, see p. 3 for battery installation information.

WALL MOUNT INSTALLATION

Your phone can be mounted on a wall phone plate (not included).

1. Rotate the handset hook one-half turn.
2. Plug one end of the telephone line cord into the jack marked PHONE LINE on the back of the unit. Wrap the excess cord around the plastic tabs. Plug the other end of the telephone line cord into a modular wall jack.
3. Attach the wall mount bracket by turning the T-shaped bracket upside down, as pictured. Then put the tabs at the bottom of the bracket into the matching slots near the bottom of the unit and snap the top tab into place.
4. Plug the AC adapter into the back of the phone and into an AC outlet.

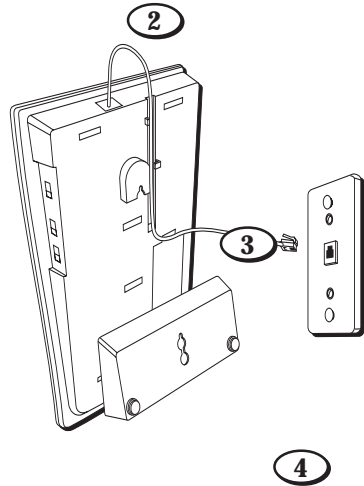
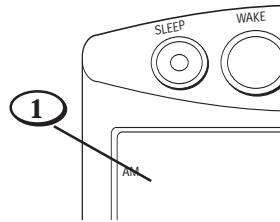

- Slip the mounting holes over the wall plate posts and slide the unit down firmly into place.

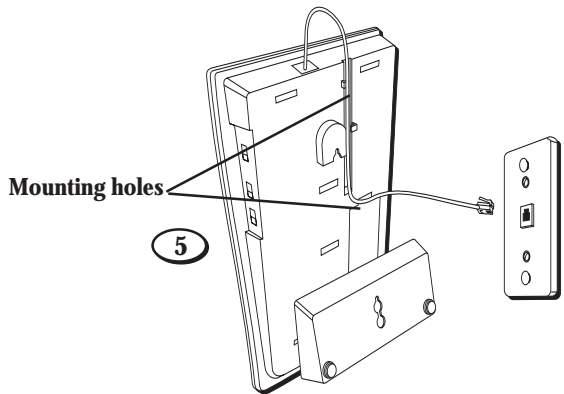

- Plug one end of the handset cord into the handset and the other end into the unit. Hang up the phone.

- Set the PULSE/TONE switch on the left side of the phone to TONE if you use touch-tone service; set it to PULSE if you have rotary service.

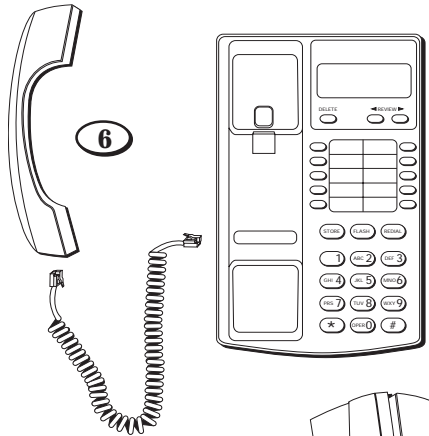

- Adjust the RINGER volume switch on the left side of the phone to the desired setting (the phone will only ring with the ringer set to LO or HI).

- Adjust the ANSWERER volume switch on the right side of the phone to the desired setting.

NOTE: Make sure that you have inserted the battery before installing the phone. If you have not, see p. 3 for battery installation information.

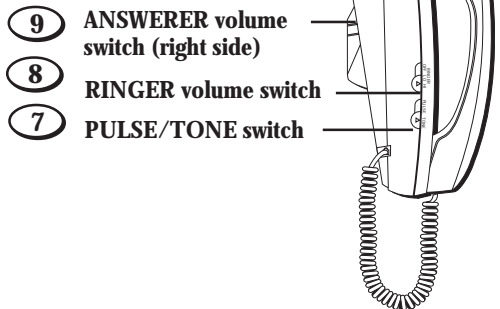

BATTERY LOW INDICATOR

When a battery has not been installed or needs to be replaced, the BATT. LOW indicator flashes rapidly.

ANSWERING MACHINE SETUP

This section shows you how to set up your answering machine to receive incoming calls. Before you begin the setup, you must be sure the answerer is on.

TURNING ON THE ANSWERING MACHINE

Press and hold the ANS.ON button to turn the answering machine on and off (the unit beeps twice and a voice prompts "functions on" or "functions off").

NOTE: The unit takes approximately 10 seconds to emit the voice prompts "functions on" or "functions off."

When the answerer is on, the MESSAGES/ANSWER ON indicator lights. When the day and time need to be set or the outgoing announcement needs to be recorded, the MESSAGES/ANSWER ON indicator light flashes rapidly.

SETTING THE VOICE TIME/DAY

- Press and hold the DAY button to set the day of the week.
- Press the HOUR button to set the hour (a.m. or p.m.).
- Press the MINUTE button to set the minute. When you hold the MINUTE button, it advances the time in 5-minute increments.
- Press and quickly release the DAY button to review the day/time setting.

**MESSAGES/ANSWER ON
indicator light**

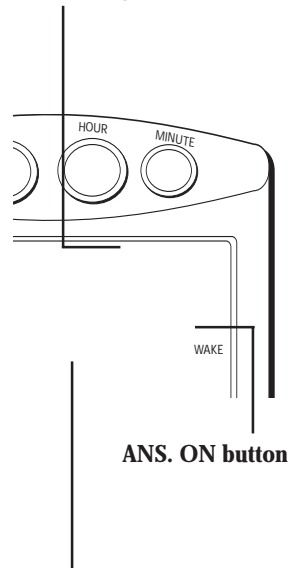

BATT. LOW indicator

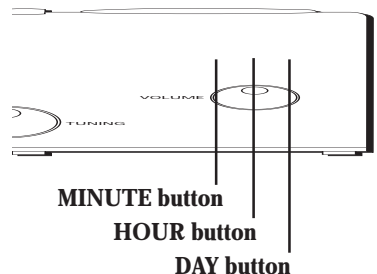

RECORDING THE OUTGOING ANNOUNCEMENT

When recording your outgoing announcement, you should be about 9 inches from the MIC, located on the front of the unit, and eliminate as much background noise as possible.

1. Press and hold the ANNOUNCE button.
2. Begin talking after you hear the tone.
3. Release the button when you finish your announcement.

SAMPLE OUTGOING ANNOUNCEMENT

Hi, this is (use your name here), I can't answer the phone right now, so please leave your name, number and a brief message after the tone, and I'll get back to you. Thanks.

REVIEWING THE OUTGOING ANNOUNCEMENT

You can review the outgoing announcement by pressing and quickly releasing the ANNOUNCEMENT button.

NOTE: You can stop the outgoing announcement by pressing STOP while the announcement is playing.

USING THE DEFAULT ANNOUNCEMENT

Your answering system is equipped with a default announcement that says *"Please leave your message after the tone."* This announcement serves as the default announcement each time the answering system loses power and is completely reset.

If you installed a battery, your answerer does not default to this announcement when the answerer loses power because your personalized outgoing announcement is retained in memory by the battery power. To set the default announcement manually; press the ANNOUNCEMENT button and release within one second after the unit beeps.

TELEPHONE OPERATION

MAKING A CALL

1. Pick up the handset to get a dial tone.
2. Dial the number.

RECEIVING A CALL

Make sure that the RINGER (on the side of the unit) is set to LO or HI.

1. Pick up the handset when the phone rings.
2. Put handset in cradle when finished with conversation.

FLASH BUTTON

To activate customer calling services such as call waiting or call transfer, press the FLASH button instead of using the hook switch. (Customer calling services are provided by your local phone company.)

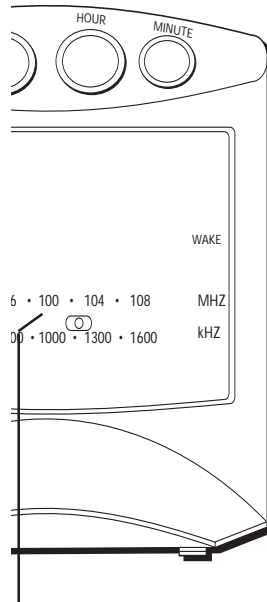

FLASH button

REDIAL BUTTON

Redial the last number you called by pressing the REDIAL button after you get a dial tone.

NOTE: Your phone's memory retains the last phone number you dialed (as many as 32 digits). If you pressed any numbers after dialing the phone number, (for example, when accessing a voice-menu system) those numbers are also redialed.

TEMPORARY TONE FEATURE

If you have Pulse (rotary) service, and want to access customer calling services that require touch-tone dialing, such as getting information from a local bank, you can use this feature.

1. Press the TONE button () after you have connected to the service in order to enable touch-tone dialing.
2. When you hang up, the phone automatically returns to pulse dialing mode.

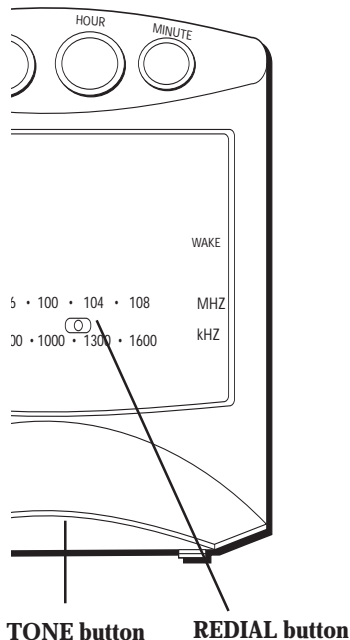

MEMORY DIALING

Store as many as 10 numbers in memory for easy dialing. Numbers can be stored in the numbered keys (0-9).

STORING A NUMBER IN MEMORY

1. Pick up the handset.
2. Press STORE.
3. Dial the number to be stored.
4. Press STORE followed by a Memory Location (0-9 on the keypad).
5. Write the phone number on the memory directory (located in the cradle area of the base, under the plastic cover).

ADDING A PAUSE TO THE DIALING SEQUENCE

Use the REDIAL button to insert a delay in the dialing sequence when storing a number (for example, when you must dial 9 to get an outside line). Press REDIAL at the point in the dialing sequence in which a pause is required:

1. Pick up the handset.
2. Press STORE.
3. Press REDIAL to add a pause, and then dial the number.
4. Press STORE followed by a Memory Location (0-9 on the keypad).

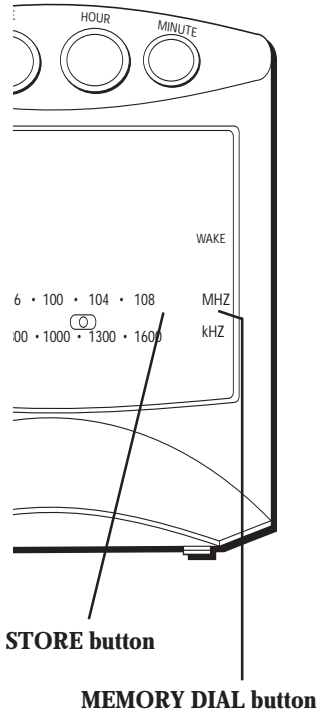

STORE button

MEMORY DIAL button

CHANGING A STORED NUMBER

Change a stored number by replacing it with a different number (see "Storing a Number in Memory"). Be sure to update your memory directory when you change numbers.

DIALING A NUMBER FROM MEMORY

You can dial numbers from memory when using the handset. When you get a dial tone, press the MEMORY DIAL button followed by the Memory Location (0-9) for the number you want to dial.

CAUTION: If you make test calls to emergency numbers, remain on the line and explain the reason for the call. Also, make these calls in off-peak hours, such as early morning or late evening.

ANSWERING MACHINE OPERATION

This section discusses the buttons and features on the answering machine.

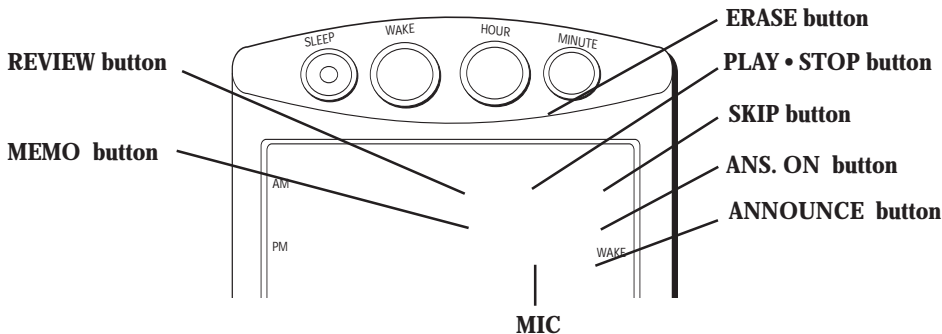

MESSAGE PLAYBACK

The MESSAGES/ANSWER ON indicator light lets you know when somebody has left a message. When you have new messages the light blinks. If you have old messages that have not been erased, the light stays on. To hear messages, press and release the PLAY•STOP button. Incoming messages are limited to 3 minutes each. Press and hold PLAY•STOP for 2 seconds to hear only new messages. (If no new messages, old messages will play).

While a message is playing, you can do the following:

- Press PLAY•STOP to stop message playback.
- Press and release REVIEW to restart the current message; continue to press and release REVIEW to go to previous messages.
- Press and hold REVIEW to review current message.
- Press and release SKIP to go to the next message.
- Press and hold SKIP to fast forward through current message.

ERASING MESSAGES DURING MESSAGE PLAYBACK

Press and release the ERASE button to erase the message currently playing.

NOTE: Messages erased during playback cannot be restored.

TOTAL MESSAGE ERASE

You can erase all the messages from memory by pressing and holding the ERASE button when the unit is not playing messages (the unit beeps to confirm the messages are erased). Note that total message erase cannot be completed if there are any unplayed messages.

NOTE: If you hear several high-pitched beeps, your answerer has not erased the messages because some of them or all of them have not been played.

You can restore messages erased this way by pressing the PLAY•STOP button—but only if you haven't activated any other answerer functions or received new messages after erasing the messages.

LEAVING A MEMO

Leaving a memo is just like recording an outgoing announcement, except you use the MEMO button instead of the ANNOUNCEMENT button.

1. Press and hold MEMO.
2. When you hear a beep, continue holding MEMO and leave your message.
3. Release MEMO when you finish your message.

The memo is included in the message count represented by the number of times the MESSAGES/ANSWER ON indicator light flashes.

CALL SCREENING/AUTO DISCONNECT

Because the answerer automatically stops recording when any extension phone is picked up (Auto Disconnect feature), you can screen incoming calls. Listen as the caller leaves a message and pick up the handset (or any extension phone) if you want to talk to that caller.

MEMORY FULL

When the memory is full, you must erase old messages so that there is room in the memory for new messages.

If the memory is full, the unit answers on the 10th ring and the MESSAGES/ANSWER ON light flashes rapidly. When using the remote access feature, you can enter your security code and then access your messages.

NOTE: The unit answers on the 10th ring when it is turned off or the memory is full. To access the answerer, enter the 3-digit security code after the beep. If memory is full, play messages and erase some of them to restore memory. If the answerer is off, press 6 to turn it on.

ACCESSING THE ANSWERER FROM ANOTHER LOCATION

You can access your answering machine from a touch-tone phone by entering the three-digit, security code after you hear the announcement. The security code is located on the underside of your telephone.

1. Dial the phone number for the answering machine.
2. Enter the 3-digit security code after you hear the tone.
3. Follow the voice menu instructions to perform the answerer functions.

The remote feature enables you to perform the following functions:

<i>To</i>	<i>Press this Button</i>
Play message	1
Repeat message	8 (while messages are playing)
Play previous message	7 (while messages are playing)
Stop message playback	3 (while messages are playing)
Erase message	0 (while messages are playing)
Skip message	9 (while messages are playing)
Turn answerer off	5
Turn answerer on	6
Record new announcement	8
Leave a message	7
Play outgoing announcement	2

TIP: You can bypass the outgoing announcement by pressing any numbered key on the keypad while the announcement is playing. Then, after the beep you can enter your security code to access the answering machine.

TOLL SAVER FEATURE

If you call to retrieve messages and there are no saved messages or new messages, the unit answers on the 5th ring. If there are saved messages or new messages, the unit answers on the 2nd ring. If you call from a remote location and you hear 3 rings, you can hang up knowing you have no new messages and avoid the toll charges.

TROUBLESHOOTING TIPS

TELEPHONE PROBLEM	SOLUTION/EXPLANATION
No dial tone Can't dial out	<ul style="list-style-type: none">• Check hook switch to make sure it pops up.• Make sure TONE/PULSE is set to correct position.• Unplug the phone, wait 30 seconds, and plug the phone back in.
Phone doesn't ring	<ul style="list-style-type: none">• Check RINGER VOLUME.• Could have too many phones on one line. (See FCC information regarding REN)
Light and tone feedback flutter when dialing in pulse mode.	<ul style="list-style-type: none">• This is normal as power is fluctuating with phone outpulsing.
Can't be heard by other party	<ul style="list-style-type: none">• Make sure phone cord is securely plugged in.
Memory dialing problems	<ul style="list-style-type: none">• Make sure you entered numbers correctly. (See "Memory Dialing.")

ANSWERING MACHINE PROBLEM**SOLUTION/EXPLANATION**

Can't hear messages

- Adjust answerer volume (p.4)
-

Time/Day Stamp
stuck at 1 a.m Monday

- Set the time/day clock (p. 7).
-

Answers on 10th ring

- Make sure answerer is turned on.
 - Memory is full. Play messages and erase them. (p. 14)
-

Incoming messages
are incomplete

- Was an extension phone picked up while the caller was leaving a message?
 - Memory is full.
 - You accidentally pressed the PLAY•STOP button during playback and stopped the message.
-

Won't respond to
commands when
you call machine from
another location

- Must use a tone-dial phone.
 - Must enter correct security code (p. 15)
 - Did the unit hang up? If you take no action for a period of time, it automatically hangs up.
-

Answer function
operates erroneously
or not at all.

- Unplug the power cord from the back of the unit and plug it back in to reset the answerer.
-

CARE AND MAINTENANCE

To keep your GE telephone working and looking good, follow these few simple guidelines:

- Avoid putting the phone near heating appliances and devices that generate electrical noise. (i.e., motors, fluorescent lamps.)
- Phone should not be exposed to direct sunlight or moisture.
- Avoid dropping the handset and other rough treatment.
- Clean telephone with a soft cloth. (Remember to first unplug the phone from the wall outlet.)
- Never use a strong cleaning agent or abrasive powder, as this will damage the finish.
- Retain the original packaging for future use.

SERVICE

The FCC requires this product be serviced only by the manufacturer or its authorized service agents. In accordance with FCC requirements, changes or modifications not expressly approved by Thomson Consumer Electronics could void the user's authority to operate this product. For instructions on how to obtain service, refer to the warranty included in this guide or call customer service's telephone number: 800-448-0329.

Attach your sales receipt to the booklet for future reference or jot down the date this product was purchased or received as a gift. This information will be valuable if service should be required during the warranty period.

Purchase date _____

Store Name _____

INDEX

A

- ANS. ON button 7
- Answering machine setup 7
- Accessing answering machine from another location 15

B

- Battery Installation 3
- Battery safety precautions 3
- BATT. LOW indicator 7

C

- Care and maintenance 18

E

- ERASE button 13
- Erasing messages 13, 14

F

- FLASH button 9

H

- Handset 2

M

- Memo 14
- Memory dialing
 - storing a number 11
 - dialing a stored number 12
- Message playback 13
- Modular jack 2

O

- Outgoing announcement 8
 - recording 8
 - reviewing 8

P

- Parts checklist 2
- Pulse (rotary) service 10
- PULSE/TONE switch 4, 7

R

- REDIAL button 10
- Remote access
 - from another location 15
- Review an outgoing announcement 8
- REVIEW button 13
- RINGER volume switch 4, 7

S

- Security code 15
- Service 18
- Setup 2-7
- SKIP button 13
- STOP button 13

T

- Tabletop installation 4
- Temporary tone feature 10
- Time/Day stamp setting up 7
- Troubleshooting tips 16

W

- Wall mount installation 5

LIMITED WARRANTY

What your warranty covers:

- Any defect in materials or workmanship.

For how long after your purchase:

- Two years.

(The warranty period for rental units begins with the first rental or 45 days from date of shipment to the rental firm, whichever comes first.)

What we will do:

- Provide you with a new, or at our option, a refurbished unit.
- The exchange unit is under warranty for the remainder of the original product's warranty period.

How to make a warranty claim:

- Properly pack your unit. Include any cables, etc., which were originally provided with the product. We recommend using the original carton and packing materials.
- Include in the package evidence of purchase date such as the bill of sale. Also print your name and address and a description of the defect. Send standard UPS or its equivalent to:

Thomson Consumer Electronics, Inc.

Product Exchange Center

32 Spur Drive

El Paso, Texas 79906

- Pay any charges billed to you by the Exchange Center for service not covered by the warranty.
- A new or refurbished unit will be shipped to you prepaid freight.

What your warranty *does not* cover:

- Customer instruction. (Your Owner's Manual provides information regarding operating instructions and user controls. For additional information, ask your dealer.)
- Installation and set-up service adjustments.
- Batteries.
- Damage from misuse or neglect.
- Products which have been modified or incorporated into other products.
- Products purchased or serviced outside the USA.
- Acts of God, such as but not limited to lightning damage.

Product Registration:

- Please complete and mail the Product Registration Card packed with your unit. It will make it easier to contact you should it ever be necessary. The return of the card is not required for warranty coverage.

How state law relates to this warranty:

- This warranty gives you specific legal rights, and you may have other rights which vary from state to state.

If you purchased your product outside the USA:

- This warranty does not apply. Contact your dealer for warranty information.

Model 2-9827A
347A8329-0001 (Rev. 1 E/S)
96-15
Printed in China

 **THOMSON CONSUMER ELECTRONICS**

P.O. Box 1976, Indianapolis, IN 46206
© 1996 Thomson Consumer Electronics, Inc.
Trademark(s) ® Registered
Marca(s) Registrada(s)

Free Manuals Download Website

<http://myh66.com>

<http://usermanuals.us>

<http://www.somanuals.com>

<http://www.4manuals.cc>

<http://www.manual-lib.com>

<http://www.404manual.com>

<http://www.luxmanual.com>

<http://aubethermostatmanual.com>

Golf course search by state

<http://golfingnear.com>

Email search by domain

<http://emailbydomain.com>

Auto manuals search

<http://auto.somanuals.com>

TV manuals search

<http://tv.somanuals.com>