



FOOD PROCESSOR

Model Number

169141 (US),

169142 (Canada)

UPC: 681131691413 (US),

681131691420 (Canada)



Thank you for purchasing a GE small appliance.

In keeping with the GE ecomagination initiative, please consider the option to recycle the packaging material and donate the appliance you are no longer using.

To read more about GE's ecomagination commitment visit:
ge.ecomagination.com

IMPORTANT SAFEGUARDS

When using electrical appliances, basic safety precautions should always be followed, including the following.:

- **READ ALL INSTRUCTIONS. KEEP THESE INSTRUCTIONS FOR FUTURE USE.**
- To protect against risk of electrical shock, do not put base, cord, or plug in water or other liquid.
- Close supervision is necessary when any appliance is used by or near children.
- Turn unit off and unplug from outlet when not in use, before putting on or taking off parts, and before cleaning. To disconnect, turn unit off, grasp plug, and pull out from wall outlet. Never yank on cord.
- Avoid contacting moving parts.
- Do not operate any appliance with a damaged cord or plug or after the appliance malfunctions, or has been damaged in any manner. Call our toll-free customer service number for information on examination, repair or adjustment.
- The use of attachments not recommended or sold by the appliance manufacturer may cause fire, electric shock, or injury.
- Do not use outdoors.
- Do not let cord hang over edge of table or counter or touch hot surfaces.
- Keep hands and utensils away from moving blades or Discs while processing food to prevent the possibility of severe personal injury or damage to the food processor. A scraper may be used but must be used only when the food processor is not running.
- Blades are sharp. Handle carefully.
- Do not touch the blades when inserting or removing the Chopping Blade and Slice/Shred Disc.
- To avoid injury, never place Chopping Blade or Slice/Shred Disc on Base without first putting Bowl properly in place. Make sure motor, Disc, and/or Chopping Blade have stopped completely before removing cover.
- Be certain cover is securely locked in place before operating appliance.
- Never feed food into chute by hand. Always use Food Pusher.
- Do not operate this appliance in the presence of explosive and/or flammable fumes.
- This appliance is intended for household use only, not for commercial or industrial use. Use for anything other than intended will void the warranty.
- Do not attempt to defeat the cover interlock mechanism.
- Do not leave the appliance unattended while it is running.
- Moving Parts. Keep fingers out of discharge opening.

SAVE THESE INSTRUCTIONS!

OTHER CONSUMER SAFETY INFORMATION

THIS APPLIANCE IS INTENDED FOR HOUSEHOLD USE ONLY.

Polarized Plug

This appliance has a polarized plug—one blade is wider than the other. As a safety feature, this plug will fit into a polarized outlet only one way. If the plug does not fit fully into the outlet, reverse it and try again. If it still does not fit, contact an electrician.

Do not attempt to defeat this safety feature.

Bottom Cover

To reduce the risk of fire or electric shock, do not attempt to remove the bottom cover. There are no user serviceable parts inside.

Before First Use

- When unpacking the product and removing packing material, handle the Chopping Blade, and Slice/Shred Disc carefully; they are very sharp.
- Wash all parts except the Base in hot, soapy water. Rinse them dry. These parts can also be placed in the dishwasher. Be sure to read this Use & Care Book to learn the correct methods for taking the unit apart and cleaning.

PARTS

1. Movable loop
2. Bowl Lid
3. Slice/Shred Disc
4. Disc Stem
5. Bowl
6. Center Post
7. Base
8. Control Panel
9. Food Chute Lid
10. Food Chute
11. Slide button
12. Chopping Blade
13. Food Pusher

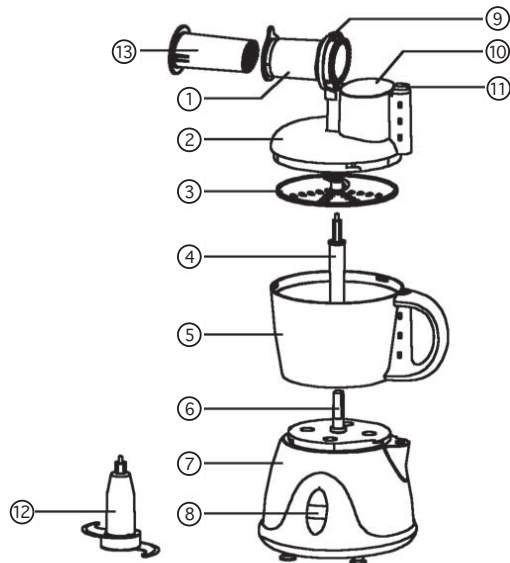

1. **pulse**—Pulse button must be pressed and held for unit to operate. When released, unit will stop. Use PULSE for short processing tasks, such as chopping nuts, raw meats, or vegetables. This lets you check processed results and control the consistency.
2. **on**— When this button is pressed, unit runs continuously until OFF button is pressed.
3. **off**— Processor should always be left in OFF position when not in use.

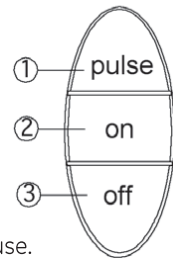

USING YOUR FOOD PROCESSOR

Note: Do not attempt to chop ice in this food processor; it will damage the bowl and dull the Chopping Blade. This unit will not whip cream, beat egg whites to a desirable volume, grind coffee beans, spices or other items with high oil content, or slice or shred hard-cooked eggs, marshmallows, or soft cheeses.

Important: For your protection, this unit has an interlock system. The processor will not operate unless the bowl is properly locked onto base and cover is properly locked onto the bowl. Do not attempt to operate the unit without the bowl lid, bowl and food chute lid correctly in place. Be sure base is on a flat, dry and clean surface before you begin processing.

How to assemble the Bowl

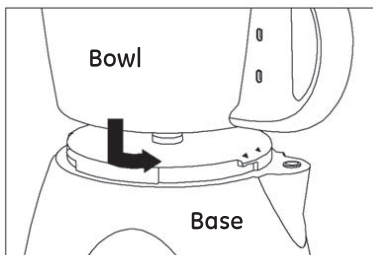



Fig. 1

Align the base and bowl as illustrated Fig. 1. Align the bowl handle with the  mark on the base. Turn the bowl counterclockwise until it clicks onto the base. The bowl handle should now align with the  mark on the base.

Note: There is only one position for the bowl to lock onto the base. The unit will not operate if the bowl does not lock onto the base.

How to lock the Cover

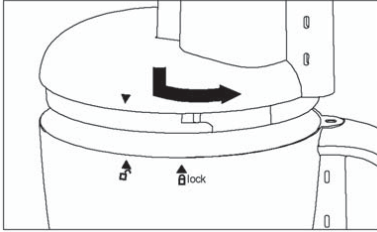

Fig. 2

Place the cover onto the bowl. Align the ▼ mark on the cover and the unlock mark on the bowl (as illustrated in Fig. 2).

Twist the cover counter-clockwise towards LOCK until it clicks onto the bowl.

The ▼ mark on the cover should now align with the lock mark on the bowl.

Note: When cover is locked into position, the safety mechanism on the cover and bowl will align. The unit will not operate if the cover is not locked onto bowl.

How to lock the Food Chute Lid

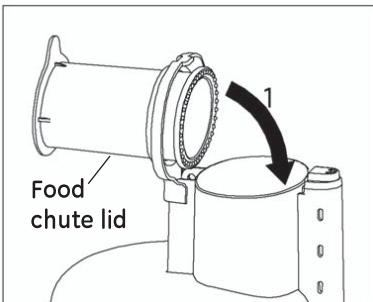

Fig. 3

The Food Chute lid hinges onto back of food chute.

As illustrated in Fig. 3.

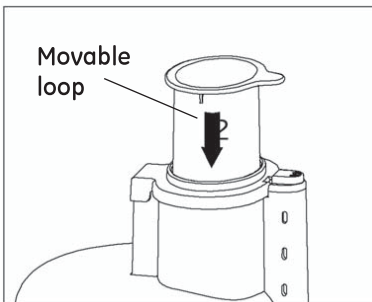
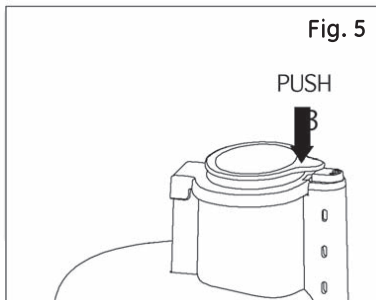

Fig. 4

Push down the Movable loop into the food chute.

As illustrated in the Fig. 4.



Push on the tab of Movable Loop to latch the Food Chute lid onto the food chute. As illustrated in Fig. 5.

Note: Unit will not operate if the food chute lid does not latch onto the food chute.

How to Open the Food Chute Lid

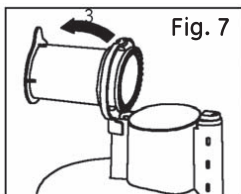
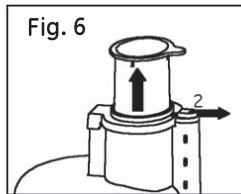

1. Pull up the Movable Loop
2. Pull slide release button out
3. Pull back the food chute lid and Movable loop

Note: Before opening food chute lid, turn the unit OFF and unplug the cord

How to Chop

Note: Make sure the unit is turned OFF and unplugged before use. Never use hand to push food into processor. Do not use the processor continuously for more than 3 minutes at a time.

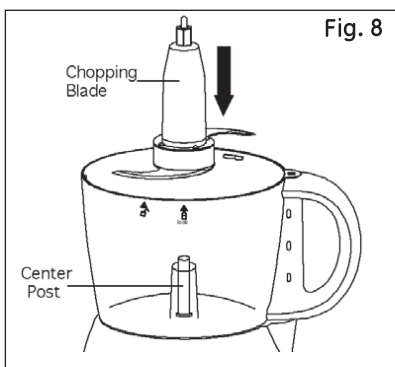

1. Lock the bowl onto base. (See "How to assemble the bowl")
2. Grasp the chopping blade by its base and slide it onto the center post. (Fig. 8)
3. Place food into bowl.
4. Lock cover onto bowl. (See "How to Lock the cover")
5. Lock the Food Chute Lid. (See "How to lock the food chute lid"). Insert food pusher into Movable loop.

6. Plug the cord into an electric outlet. Use the Food Guide to prepare food for chopping.
7. Press Pulse to run unit (or press ON for continuous processing). When pulsing, hold the Pulse position for about 2-3 seconds, check results, repeat if desired.
8. When finished processing, release the Pulse button, or if you were using continuous ON, press OFF, allow the chopping blade to stop rotating.
9. Take out the food pusher Twist the cover towards the unlock mark to remove.
10. Hold the Chopping Blade by its base and remove. Unlock the bowl by turning it clockwise towards the UNLOCK mark, and lift off. Empty the processed food.

Note: Chopping Blade is very sharp, use caution when handling.

How To Slice Or Shred

Note: Make sure the unit is turned OFF and unplugged before use.

Never use hand to push food into processor. The use of heavy pressure will not speed operation. Do not use the processor continuously for more than 3 minutes at a time .

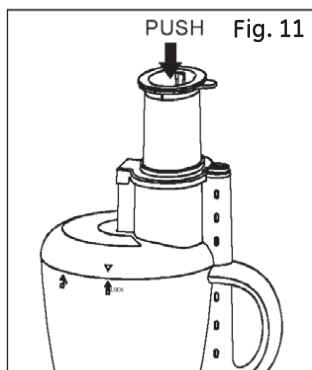
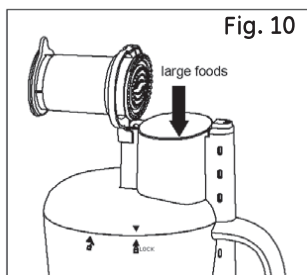
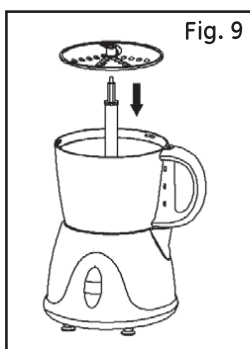

Process large food

1. Lock the bowl onto base, see "How to Assemble the bowl".
2. Slide the disc stem onto the center post of the base. With the desired side facing up (slicing or shredding), push the slice/shred disc onto the disc stem (Fig. 9). **Use caution when handling disc, blades are extremely sharp.**
3. Lock cover onto bowl, see "How to Lock the Cover".
4. Fill the food chute with large food such as chunk of cabbage, green pepper, whole tomato (Fig. 10). Lock the food chute lid. (See "How to lock the Food Chute Lid"). Use the Food Guide to help you prepare food for slice/shred processing.
5. Slide the food pusher into the Movable loop, plug the cord into an electric outlet.
6. Firmly press the ON button, then press down lightly but firmly on the food pusher. (Fig. 11)
7. When food chute is empty, press OFF, allow the disc to stop rotating. Twist the food chute/cover towards the UNLOCK mark to remove the cover.
8. Carefully remove the Shredding Disc. Unlock the bowl by turning it clockwise towards the UNLOCK mark, and lift off. Empty the processed food.

Note: Shredding Disc is very sharp, use caution when handling.

Fig. 12

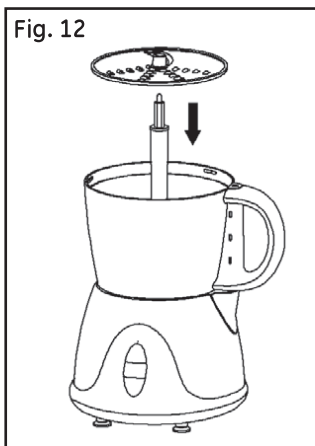

Process long and thin food

Note: Make sure the unit is turned OFF and unplugged before use.

Never use hand to push food into processor. Do not use the processor continuously for more than 3 minutes at a time.

1. Lock the bowl onto base, see "How to assemble the bowl".
2. Slide the disc stem onto the center post of the base. With the desired side facing up (slicing or shredding), push the slice/shred disc onto the disc stem (Fig. 12). **Use caution when handling disc, blades are extremely sharp.**
3. Lock cover onto bowl, see "How to Lock the Cover".
4. Lock the Food Chute Lid. (See "How to lock the food chute lid". Food chute lid can be locked before locking cover onto bowl.)
5. Fill the Movable loop with long and thin food such as potato, pepperoni, carrots, celery. Insert food pusher into Movable loop (Fig. 13).
6. Firmly press the ON speed button, then press down lightly but firmly on food pusher.
7. When finished processing, press OFF, allow the disc to stop rotating, Twist the food chute/cover towards the UNLOCK mark to remove the cover.
8. Carefully remove the Shredding Disc. Unlock the bowl by turning it clockwise towards the UNLOCK mark, and lift off. Empty the processed food.

Fig. 13

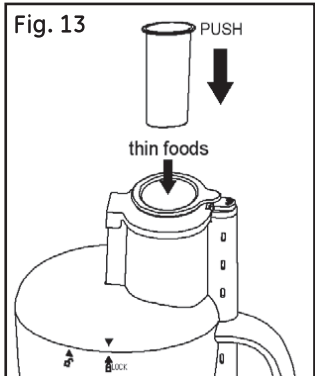

Note: Shredding Disc is very sharp, use caution when handling.

Food Processing Tips/Liquids

1. Hot liquids (less than 80°C) and hot foods can be processed in the bowl.
2. Be sure to process small amounts of liquids-2 cups or less at a time. Larger amounts may leak from the bowl.

Care & Cleaning

NOTE: Do not attempt to sharpen the cutting edges of the chopping blade or the reversible disc. They are permanently sharpened at the factory and will be ruined by attempted sharpening.

CLEANING

1. Before cleaning, be sure the unit is switched off and the cord is unplugged.
2. Whenever possible, rinse parts immediately after processing for easy cleanup.
3. Wipe the base, control knob, and feet with a damp cloth and dry thoroughly. Stubborn spots can be removed by rubbing with a damp cloth and a mild, non-abrasive cleaner. Do not immerse the base in liquid.
4. All removable parts can be washed by hand or in a dishwasher, top rack.
 - If washing by hand, wash in hot, sudsy water, rinse, and dry thoroughly. If necessary, use a small nylon bristle brush to thoroughly clean the bowl and food chute/cover, this type of brush will also help prevent cutting yourself on the chopping blade and slice/shred disc.
 - If washing in a dishwasher, place removable parts on the top rack only-not in or near the utensil basket.
5. Do not use rough scouring pads or cleansers on any plastic or metal parts.
6. Do not fill the bowl with boiling water or place any of the parts in boiling water. Some foods, such as carrots, may temporarily stain the bowl. To remove stains, make a paste of 2 tablespoons (30ml) baking soda and 1 tablespoon (15ml) warm water. Apply the paste to the stains and rub with a cloth. Rinse in sudsy water and dry.

CHOPPING GUIDE

Food	Amount	Directions
Baby Food	Up To 4 Cups (1000ml)	Add Up To 4 Cups(1000ml) Cooked Vegetables And/or Meat To Bowl, Along With 1/4 Cup(60ml) Liquid Per Cup Of Solid Food, Process Continuously To Desired Fineness.
Bread Crumbs	Up To 5 Slices	Cut Either Fresh Or Dry Bread Slices Into 1 1/2-2 Inch (3.75&5cm) Pieces. Add To Bowl And Process To Fine Crumbs.
Cookie/cracker Crumbs	Up To 5 Cups (1250ml)	Use For Crumbing Graham Crackers, Chocolate Or Vanilla Wafers. Break Larger Crackers Into 1 1/2-2 Inch (3.75&5cm) Pieces. Add To Bowl And Process Until Fine.
Cranberries, Minced	3 Cups (750ml)	Pulse To Chop To Desired Fineness. Can Also Add Sugar To Make Cranberry Relish.
Eggs, Chopped	Up To 12	Peel, Dry And Halve Hard-cooked Eggs. Add To Bowl. Pulse To Chop, Checking Fineness After 4-5 Pulses.

CHOPPING GUIDE (continued)

Food	Amount	Directions
Garlic, Minced	Up To 12	Be Sure Bowl Is Dry. Drop Clove(S) Down Food Chute While Unit Is Running.
Meat, chopped (Raw Or Cooked)	Up To 2.5 Cups (600ml)	Cut The Meat Into 1"(2.54cm) Cubes. Add To Bowl And Pulse To Chop.
Mushrooms, Chopped	Up To 12 Medium	Halve Large Ones And Add To Bowl. Pulse To Desired Fineness.
Nuts, Chopped	2 Cups (300ml)	Add To Bowl And Pulse To Chop.
Onions, Chopped	Up To 2 Large	Quarter, And Add To Bowl. Pulse 1 Or 2 Times To Coarsely Chop. For Green Onions, Up To 2 Cups (500ml) Cut Into 1" (2.54cm) Pieces.
Parmesan Or Romano Cheese, Grated	Up To 1-1/2 Cups(375ml)	Allow Cheese To Reach Room Temperature. Cut Into 1"(2.54cm) Cubes. Add To Bowl And Pulse To Coarse Chop; Process Continuously To Finely Grate.
Parsley, Chopped	Up To 2 Cups (500ml)	Add To Bowl And Pulse To Chop To Desired Fineness, Abort 10-15 Seconds Process Other Herbs In Same Manner (Basil, Cilantro, Mint).
Pepper, Green, Red, Yellow Chopped	Up To 1 Pepper	Cut Into 1"(2.54cm) Pieces. Add To Bowl And Pulse To Chop.
Soups, Pureed Or Creamed	2 Cups (500ml)	Add Up To 2 Cups Hot(Less Than 80_) Vegetable Soup For Pureeing And Creaming. Process To Desired Smoothness
Squash (Butternut), Pumpkin Or Sweet Potatoes Pureed	Up To 5 Cups (1250ml), 1"(2.54cm) Cubes	Add 1/4 Cup(60ml) Of Cooking Liquid Per Cup Of Food . Pulse To Finely Chop Then Process Continuously To Puree.
Strawberries, Pureed	2 Cups(500ml)	Hull And Halve Large Berries. Add To Bowl And Pulse To Chop. Process Continuously To Puree.
Tomatoes, Chopped	4 Medium	Quarter Tomatoes. Add Up To 4 And Pulse To Desired Size.

SHREDDING GUIDE

Food	Directions
Cabbage	Use Shredding Disc For Very Fine Cabbage Or Slaw. Cut Into Pieces To Fit Chute. Shred Using Light Pressure. Empty Bowl As Cabbage Reaches Disc.
Carrots	Position In Chute And Shred.
Cheese,cheddar	Cheese Must Be Well Chilled. Cut To Fit Chute.
Cheese, Mozzarella	Cut To Fit Chute. Cheese Must Be Chilled In Freezer For 30 Minutes Prior To Shredding. Use Light Pressure.
Potatoes	Cut To Fit Chute.
Zucchini	Cut To Fit Chute, Either Lengthwise Or Horizontally.

SLICING GUIDE

Food	Directions
Apple	Halve And Stack Horizontally In Chute. Use Firm Pressure.
Cabbage/lettuce	Halve Head, Cut To Fit Chute.
Carrots	Cut To Fit Chute.
Celery	Remove String. Pack Chute For Best Results.
Cucumber	Cut To Fit Chute If Necessary.
Mushrooms	Stack Chute With Mushrooms On Their Sides For Lengthwise Slices.
Onions	Halve And Fill Chute, Positioning Onions Upright For Coarsely Chopped Results.
Peaches/pears	Halve And Core. Position Upright In Chute And Slice Using Light Pressure.
Peppers, Green,red,yellow Etc.	Halve And Seed. Fit Pepper Up Bottom Of Chute, Squeezing Slightly To Fit If Necessary. Cut Large Ones Into Quarters Or Strips, Depending On Desired Results. Slice Using Moderate Pressure.
Pepperoni	Cut Into3"(8cm) Lengths. Remove Inedible Casing.
Potatoes	Peel If Desired. Position In Chute, Cutting Large Potatoes In Halves.
Strawberries	Hull. Arrange Berries On Their Sides For Lengthwise slices.
Tomatoes	Use Small Tomatoes For Whole Slices, Halve If Necessary. Use Gentle, But Firm Pressure.
Turnips	Peel. Cut Turnips To Fit Chute.
Zucchini	Slice Off Ends. Use Small Squash For Whole Slices; Halve Larger Ones To Fit Chute.

CUSTOMER ASSISTANCE

If you have a claim under this warranty, please call our Customer Assistance Number. For faster service, please have the model number and product name ready for the operator to assist you. This number can be found on the bottom of your appliance and on the front page of this manual.

Model Number: _____ **Product Name:** _____

Customer Assistance Number 1.877.207.0923 (US) or 1.877.556.0973 (Canada)

Keep these numbers for future reference!

For more information, please visit us at WWW.GEHOUSEWARES.COM

TWO-YEAR LIMITED WARRANTY

What does your warranty cover?

- Any defect in material or workmanship.

For how long after the original purchase?

- Two years.

What will we do?

- Provide you with a new one.
- For those items still under warranty but no longer available, WAL-MART reserves the right to replace with a similar GE branded product of equal or greater value.

How do you make a warranty claim?

- Save your receipt.
- Properly pack your unit. We recommend using the original carton and packing materials.
- Return the product to your nearest WAL-MART store or call Customer Assistance at 1-877-207-0923 (U.S.) or 1-877-556-0973 (Canada).

What does your warranty not cover?

- Parts subject to wear, including, without limitation, glass parts, glass containers, cutter/strainer, blades, seals, gaskets, clutches, motor brushes, and/or agitators, etc.
- Commercial use or any other use not found in printed directions.
- Damage from misuse, abuse, or neglect, including failure to clean product regularly in accordance with manufacturer's instructions.

How does state law relate to this warranty?

- This warranty gives you specific legal rights, and you may also have other rights which vary from state to state or province to province.
- This warranty is in lieu of any other warranty or condition, whether express or implied, written or oral, including, without limitation, any statutory warranty or condition of merchantability or fitness for a particular purpose.
- WAL-MART, GE and the product manufacturer expressly disclaim all responsibility for special, incidental and consequential damages or losses caused by use of this appliance. Any liability is expressly limited to an amount equal to the purchase price paid whether a claim, however instituted, is based on contract, indemnity, warranty, tort (including negligence), strict liability, or otherwise. Some states or provinces do not allow this exclusion or limitation of incidental or consequential losses so the foregoing disclaimer may not apply to you.

What if you encounter a problem with this product while using it outside the country of purchase?

- The warranty is valid only in the country of purchase and you follow the warranty claim procedure as noted.



is a trademark of General Electric Company and is used under the license by Wal-Mart Stores Inc., Bentonville, AR 72716

Marketed in Canada by:

Wal-Mart Canada Corp.
1940 Argenta Road, Mississauga, Ontario L5N1P9

Free Manuals Download Website

<http://myh66.com>

<http://usermanuals.us>

<http://www.somanuals.com>

<http://www.4manuals.cc>

<http://www.manual-lib.com>

<http://www.404manual.com>

<http://www.luxmanual.com>

<http://aubethermostatmanual.com>

Golf course search by state

<http://golfingnear.com>

Email search by domain

<http://emailbydomain.com>

Auto manuals search

<http://auto.somanuals.com>

TV manuals search

<http://tv.somanuals.com>