

OSMONICS TONKAFLO[®] PUMPS QSV SERIES



INSTALLATION, OPERATION, AND MAINTENANCE MANUAL

For QS1800V and QS2800V Series
Tonkaflo Centrifugal Pumps with
Quiet, Stainless Steel Vertically
Mounted, Flow-Cooled Motors

GE Infrastructure
Water & Process Technologies



OPERATION AND MAINTENANCE MANUAL

**FOR SERIES QS1800V AND QS2800V SERIES
TONKAFLO® PUMPS**

TABLE OF CONTENTS

	<u>Page</u>
1.0 INTRODUCTION.....	1
2.0 TONKAFLO SPECIFICATION	2
2.1 Pump Label Nomenclature	2
2.2 Performance Specifications.....	3
2.3 Material Specifications.....	4
3.0 PUMP INSTALLATION	5
3.1 Inspection	5
3.2 Pump Mounting and Location	5
3.3 Operation Safeguards.....	6
3.4 Inlet and Discharge.....	6
3.4.1 Inlet Piping.....	6
3.4.2 Discharge Piping.....	7
3.4.3 Piping Connections.....	7
3.4.4 Inlet Line Screen/Filter	7
3.4.5 Discharge Screen (Strainer)	8
3.5 Pump Priming	9
3.6 Motor Wiring.....	10
3.6.1 Single-Phase Motors.....	10
3.6.2 Three-Phase Motors.....	11
3.6.3 Three-Phase Power Imbalance	12
3.6.4 Wire Sizing.....	12
3.7 Electrical Grounding.....	13
3.8 Motor Protection.....	13
4.0 PUMP OPERATION.....	14
4.1 Priming	14
4.2 Operation	14
4.3 Restarts	14
5.0 GENERAL TROUBLESHOOTING.....	15

	<u>Page</u>
6.0	FIELD MAINTENANCE.....20
6.1	Flow-Cooled Motor and Liquid End - Tonkaflo Service Policy20
6.2	Liquid End Removal and Installation.....20
7.0	TONKAFLO RETURN GOODS AUTHORIZATION (RGA) PROCEDURE.....23
7.1	Motor Warranty.....23
7.2	In-Warranty Pump Failures23
7.3	Out-of-Warranty Pump Failures.....23
7.4	Shipping Charges.....23
	7.4.1 In-Warranty23
	7.4.2 Out-of-Warranty.....23
8.0	DIMENSIONAL DRAWING24
9.0	REPLACEMENT PARTS.....25
9.1	Parts Schematic.....25
9.2	Parts List, Standard Models26
9.3	Accessories and QS Series Tonkaflo Pumps.....26
9.4	Ordering Parts.....27
10.0	WARRANTY.....28

LIST OF FIGURES

<u>Figure</u>	<u>Description</u>	
2.1	Pump and Motor Labels.....	2
3.2	Right Angle Inlet and Vertical Position.....	5
3.3	Discharge Screen Installation.....	8
3.4	Priming Water Level.....	9
3.5	Two Sources of Power to the Single-Phase Controller.....	10
3.6	Changing Motor Rotation.....	11
3.7	“Rolling” the Leads to Balance Current Draw.....	12
6.8	Liquid End and Motor Module.....	20
6.9	Removing Liquid End.....	21
6.10	Liquid End Removed.....	21
6.11	Component Detail.....	22
6.12	Rejoining Liquid End to Motor Module.....	22
8.13	QS1800V and QS2800V Series.....	24
9.14	Parts Schematic.....	25

LIST OF TABLES

<u>Table</u>	<u>Description</u>	
2.1	Pump Performance Summary.....	3

1.0 INTRODUCTION

This manual contains information important to the installation, operation and maintenance of your Tonkaflo[®] multi-stage centrifugal pump. Your Tonkaflo pump has been designed for reliable service in many types of pumping applications. Proper installation and normal maintenance will help ensure extended pump life and prevent costly downtime.

Before installing and operating your Tonkaflo pump, please read these instructions carefully and keep this manual handy for future reference. This manual is intended for general maintenance only.

Further information may be obtained by contacting your nearest Tonkaflo distributor or GE. Contact GE at:

GE Infrastructure
Water & Process Technologies
5951 Clearwater Drive
Minnetonka, MN 55343-8995 USA
Phone: (952) 933-2277
Fax: (952) 933-0141
Toll Free: (800) 848-1750

This manual is not intended for repair or overhaul of the Tonkaflo pump liquid ends.

Only the factory and those certified by the Factory Service School are authorized to repair, service or overhaul Tonkaflo liquid ends.

Your new Tonkaflo multi-stage centrifugal pump is designed for quiet, efficient, vertical operation in environments where noise from a fan-cooled motor is acceptable. A modular design permits the liquid end to be separated from the motor module for greater serviceability, while at the same time ensuring precise shaft alignment. The materials and construction of Quiet Submersible Verticle (QSV) pumps make them suitable for many chemical and pure water applications.

The Tonkaflo pump's multi-stage design allows the user to choose a pump model that most closely matches the desired performance and, thereby, to achieve the highest pumping efficiency. Unlike many other pump manufacturers, Tonkaflo will produce pumps to fit your particular applications should a standard model not suit your requirements.

NOTE: This manual, along with all other manuals, is available at www.gewater.com.

2.0 TONKAFLO SPECIFICATIONS

2.1 Pump Label Nomenclature

All Tonkaflo pumps use the same model number nomenclature to describe the series name, nominal flow rate, staging and operation of the pump.

Model QS2825V - 50	
QS	= Quiet Submersible
28	= Series 2800
25	= Stages
V	= Vertical Operation Only
50	= 50 Hz Operation Only

The pump label, showing model number, serial number, construction and performance, is located immediately downstream from the electrical junction box on the top side of the liquid end shell. The motor label, showing horsepower, voltage, Hz, rated amp draw, service factor and service factor amps (S.F.A.), is located immediately upstream from the junction box on the top side of the motor module. Figure 2.1 (Pump Label and Motor Label) shows these locations.

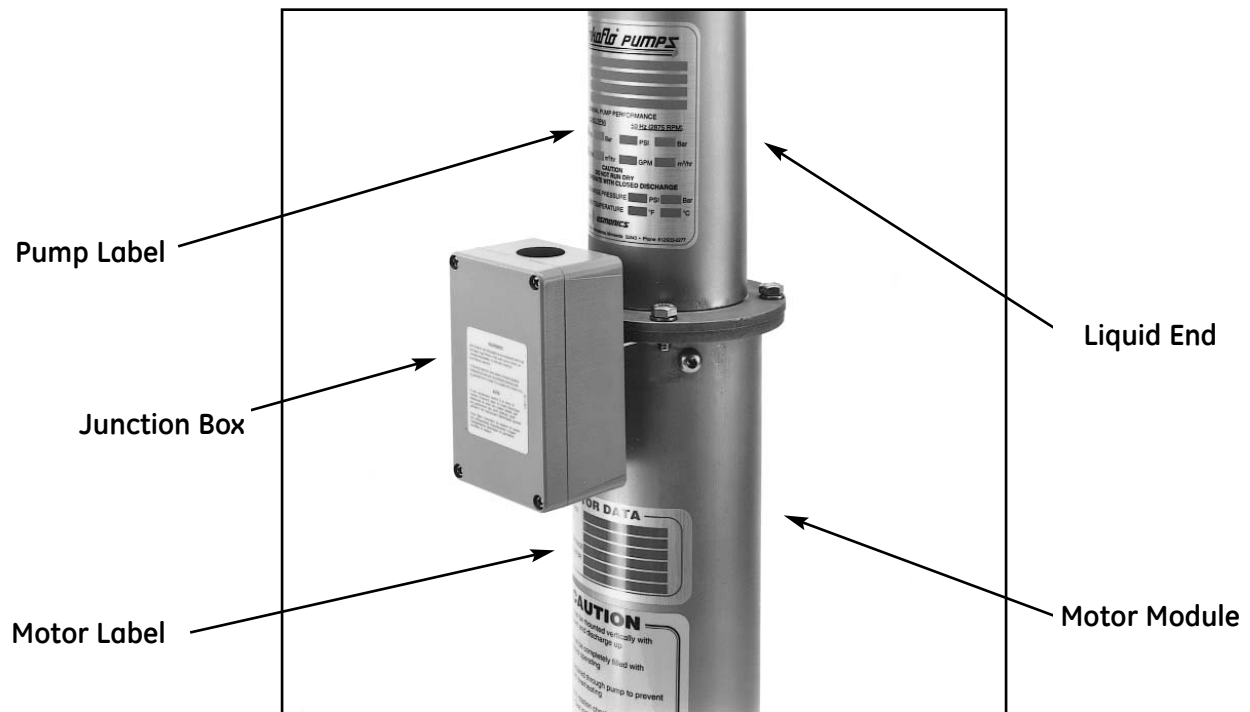

Figure 2.1
Pump and Motor Labels

2.2 Performance Specifications

2.2.1 Pump Performance

**Table 2.1
Pump Performance
Summary**

Series	60 Hz Operation (3450 rpm)			50 Hz Operation (2875 rpm)		
	Capacity gpm (m ³ /h)	Maximum Boost* psi (bar)	Max. Efficiency	Capacity gpm (m ³ /h)	Maximum Boost* psi (bar)	Max. Efficiency
QS1800V	5 - 21 (0.25 - 1.1)	420 (29.0)	56%	7 - 15 (1.6 - 3.4)	280 (19.3)	57%
QS2800V	10 - 40 (2.3 - 9.1)	350 (24.1)	64%	9 - 34 (2.0 - 7.7)	245 (16.9)	51%

* Standard model pumps shown. Higher pressures are available upon request.

2.2.2 All QSV Pumps - **IMPORTANT!**

There is no limit on pumping capacity when operating QSV pumps in parallel. The discharge pressure of your QSV pump may be increased by 100 psig (6.9 barg) by connecting another pump in series ahead of the QSV pump. Care must be taken, however, so that the inlet pressure to any QSV pump does not exceed the 100 psig (6.9 barg) maximum inlet pressure rating.

There must be adequate flow through the pump at all times to prevent excessive heat build-up.

2.3 Materials Specifications

Liquid End

Wetted Castings:	316 Stainless Steel
Pump Shell and Shaft:	316 Stainless Steel
Stages:	Noryl*
O-Ring Seals and Shaft Bearings:	Buna-N Rubber

Motor Module

Power Requirements	<u>1-Phase</u> 208, 230 V (60 Hz Operation) 220, 230, 240V (50 Hz Operation) <u>3-Phase</u> 208, 230, 460, 575V (60 Hz Operation) 220, 380, 400, 415V (50 Hz Operation)
--------------------	--

Motor Adapter and Inlet Flow Tube:	316 Stainless Steel
O-Ring Seals:	Buna-N Rubber
Motors:	Stainless steel shaft and stator shell, epoxy-encapsulated stator, electroless nickel-plated cast iron or Noryl plastic-covered carbon steel stator ends, bronze filter check valve, nitrile and neoprene rubber seals
Wire Insulation:	Neoprene, chloroprene, hypalon, and/or polyolefin epoxy-potted
Antifreeze:	20% Propylene glycol (non-toxic) 80% Water

WARNING: 90°F (32°C) MAXIMUM OPERATING TEMPERATURE

Special Liquids:

Tonkaflo pumps can handle a variety of liquids. For liquids other than water; aqueous solutions or corrosive solutes, consult your local Tonkaflo distributor or factory.

Special Materials of Construction:

Ethylene propylene dimonomer (EPDM) and Teflon* pump shaft bears are available for some models. Contact your distributor or the factory.

*Teflon is a trademark of E.I. DuPont de Nemours and Company, Inc.

3.0 PUMP INSTALLATION

3.1 Inspection

Your pump was inspected and tested at the factory prior to shipment to ensure it meets the requirements of your order. It is suggested the pump be checked upon receipt for possible damage due to shipping. Any damage should be immediately reported to the carrier.

3.2 Pump Mounting and Locations

The QSV Series pumps are intended for vertical mounting with the right angle inlet of the pump down. See Figure 2 for correct orientation. The weight of the pump and motor must be supported by setting the flat end of the outer housing on a rubber pad supported by a plate or angle. Attach the pump to the frame work of your system using **ALL** brackets included. Refer to Section 8.0 (Dimensional Drawing) for correct bracket placement.

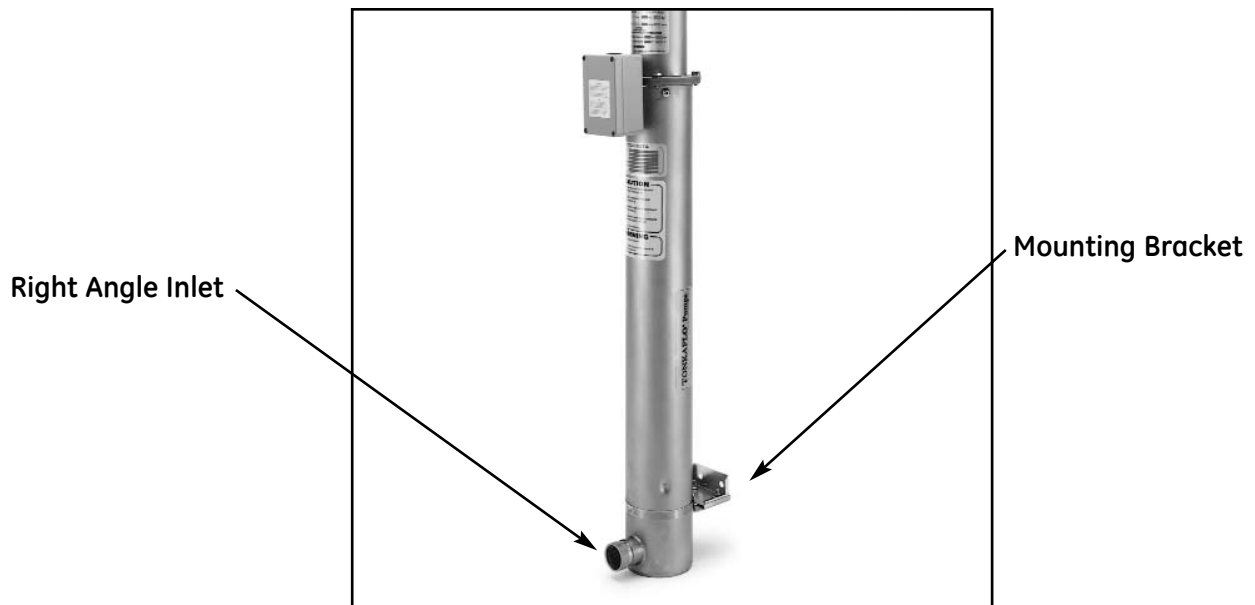

Figure 3.2
Right Angle Inlet and
Vertical Position
(QS2825V Shown)

3.3 Operation Safeguards

Quiet Submersible Vertical (QVS) Series pumps are equipped with NEMA standard flow-cooled motors, which are cooled by the process fluid. In general, flow-cooled motors have three requirements for long operational life. They are:

1. A suitable operating environment.
2. An adequate electrical supply.
3. An adequate flow of cooling water over the motor.

Quiet Submersible Vertical (QSV) Series pumps have been engineered to provide a suitable mechanical operating environment and to provide an adequate flow of cooling water over the motor, provided the pump is operated between the maximum and minimum flow rates specified for each pump series.

WARNING: CERTAIN SAFEGUARDS MUST BE IN PLACE TO PREVENT THE FOLLOWING OPERATING CONDITIONS:

- Flow rate below minimum specified flow rate
- Close discharge valve (deadheaded condition)
- Dry running
- Fluid temperature greater than 90°F (32°C)
- Low voltage
- Imbalanced three-phase power

Safeguards include low-pressure switches, low-flow shutdown, switches, temperature limit switches, quick-trip circuit breakers and properly-sized motor starter heaters. The three-phase electrical power must exhibit amperage readings in each leg within $\pm 5\%$ of the average for all three legs (Section 3.6.3, Three-Phase Power Imbalance). Consult the motor operation manual for additional information.

3.4 Inlet and Discharge - IMPORTANT!

3.4.1 Inlet Piping

- Positive feed pressure is required at all flow points.
- Avoid "high points" and other areas where air may accumulate ahead of the pump.
- The inlet piping should be at least as large as the inlet port; pipe size changes should be tapered.
- Sizing pipe to induce 3 psi (0.21 bar) pressure drop or less per 100 feet (30.5 m) is recommended.
- **NEVER** throttle the pump on the inlet side.
- The pump inlet line should be filled and tested with 20 - 100 psi (1.4 - 1.6 bar) pressure to detect any leaks prior to start-up.

3.4.2 Discharge Piping

- Select piping to handle the maximum flow and pressure developed by the pump.
- Sizing to induce 10 psi (0.70 bar) pressure drop or less per 100 feet (30.5 m) is recommended.

3.4.3 Piping Connections

The standard QSV Series pump inlet and discharge connections are grooved for Victaulic clamped-union couplings with gasket. The standard inlet and discharge connection is 1-1/4-inch Victaulic. Victaulic couplings are available worldwide. Contact the factory or your local industrial piping wholesaler.

3.4.4 Inlet Line Screen/Filter

This is a precision multi-stage pump with close tolerances to provide maximum efficiency. It is good practice to install a large area 30-mesh or finer screen, or a cartridge filter in the pump inlet line to collect any foreign objects or large particles. Size the screen or filter so as to induce a minimal pressure drop.

WARNING: THE PUMP MUST NOT BE OPERATED WITH RESTRICTED SUCTION LINE (INLET) FLOW.

Positive gauge pressure must be maintained at the pump inlet (down stream from the screen or filter). A clogged screen or filter will result in a greater pressure drop than a clean screen or filter. To prevent possible pump damage from low inlet pressure, a low-pressure alarm or shut-off switch should be located between the screen or filter and the pump. A low-flow shut-off switch should also be located in the same area.

3.4.5 Discharge Screen (Strainer)

A 30-mesh discharge screen (available as an accessory) located in the discharge piping will protect your process fluid should the pump be damaged. The installation of the screen is shown in Figure 3.3 (Discharge Screen Installation).

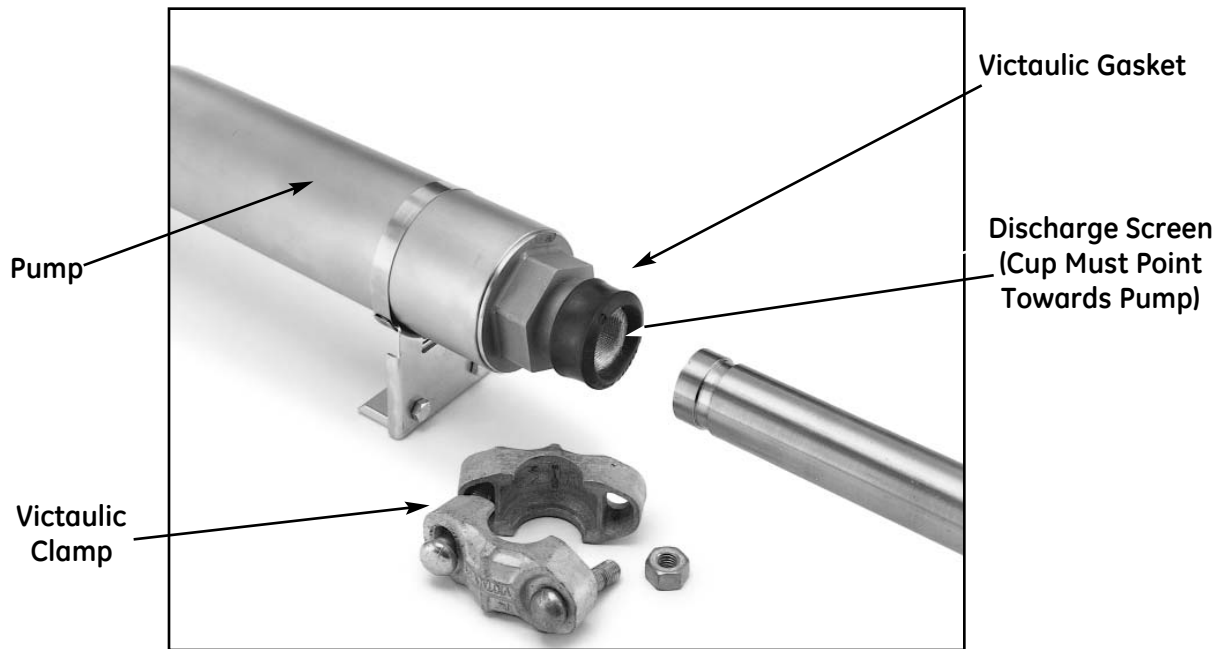

Figure 3.3
Discharge Screen
Installation

3.5 Pump Priming - IMPORTANT!

QSV pumps are not designed to be self-priming.

WARNING: THE INLET PIPING, MOTOR MODULE AND PUMP LIQUID END MUST BE COMPLETELY FILLED WITH LIQUID (PRIMED) BEFORE START-UP (Figure 3.4, Priming Pump Level).

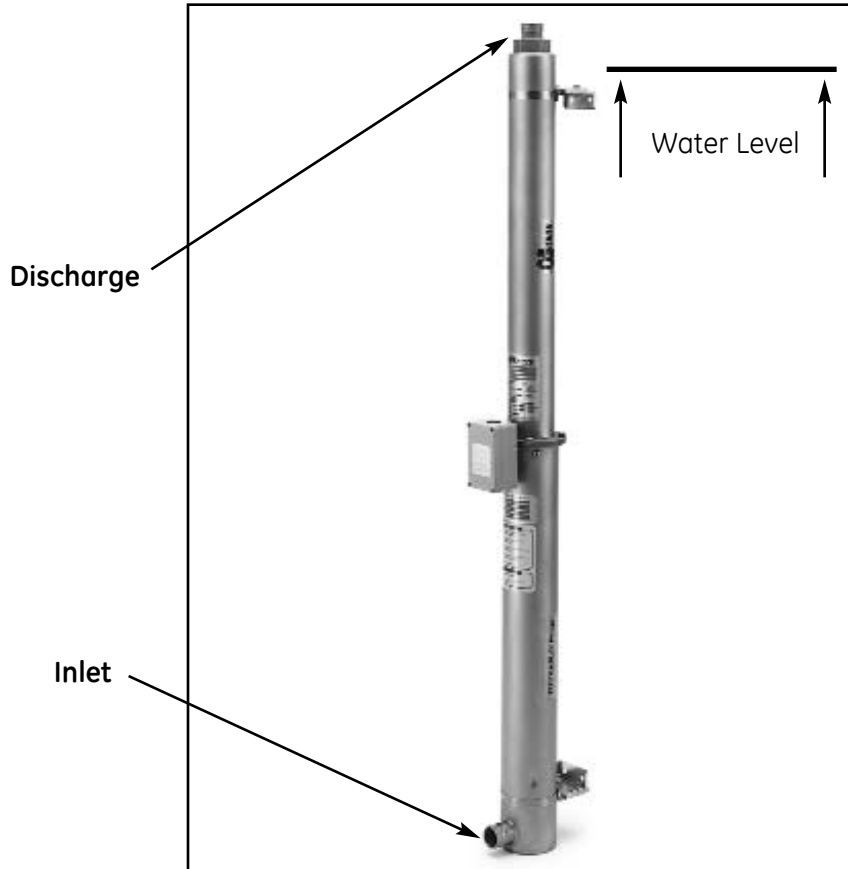

Figure 3.4
Priming Water Level

WARNING: THE PUMP MUST BE SHUT-OFF IMMEDIATELY IF PRIME IS LOST TO AVOID POSSIBLE DAMAGE TO THE INTERNAL PARTS OF THE MOTOR AND LIQUID END.

3.6 Motor Wiring

3.6.1 Single-Phase Motors - **IMPORTANT!**

Single phase three-wire motors require the use of a special controller included in a separate enclosure with each motor. The controller enclosure is not attached to the motor. Operation of motors without the controller or using the incorrect controller can result in failure of the motor and voids warranty.

The controller is mounted in a NEMA 4X enclosure and suitable for indoor or outdoor applications within temperatures of 14°F (-10°C) to 122°F (50°C).

The controller should never be mounted in direct sunlight or high-temperature locations as this will cause shortened capacitor life and unnecessary tripping of the overload protector.

The controller enclosure is designed for vertical upright mounting only. Mounting in other positions will affect its operation.

The controller must be electrically wired to the motor using minimum 8 AWG for 5 horsepower motors and 10 AWG for 3 horsepower motors.

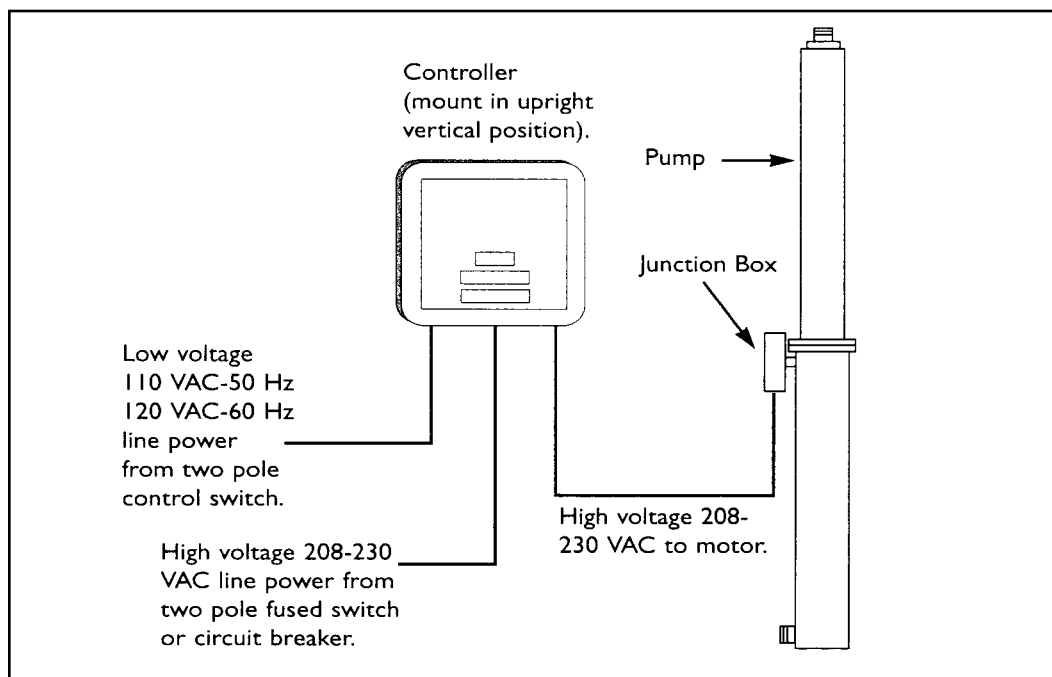

Figure 3.5
Two Sources of Power to
the Single-Phase Controller

The controller must be supplied with two sources of power. The control circuit (motor starter coil) must be electrically wired with 110 VAC-50 Hz or 120 VAC-60 Hz voltage. The power circuit must be electrically wired with single-phase to match the motor label.

3.6.2 Three-Phase Motors - **IMPORTANT!**

BEFORE STARTING THREE-PHASE MOTORS

STEPS

1. Prime pump before applying power to avoid damage to the pump and motor.
2. Check the direction of rotation.

Three-phase motors can run in either direction, depending on how they are connected to the power supply. When the three cable leads are first connected to the power supply, there is a 50% chance that the motor will run in the proper direction. To make sure the motor running in the proper direction, carefully follow the next procedure:

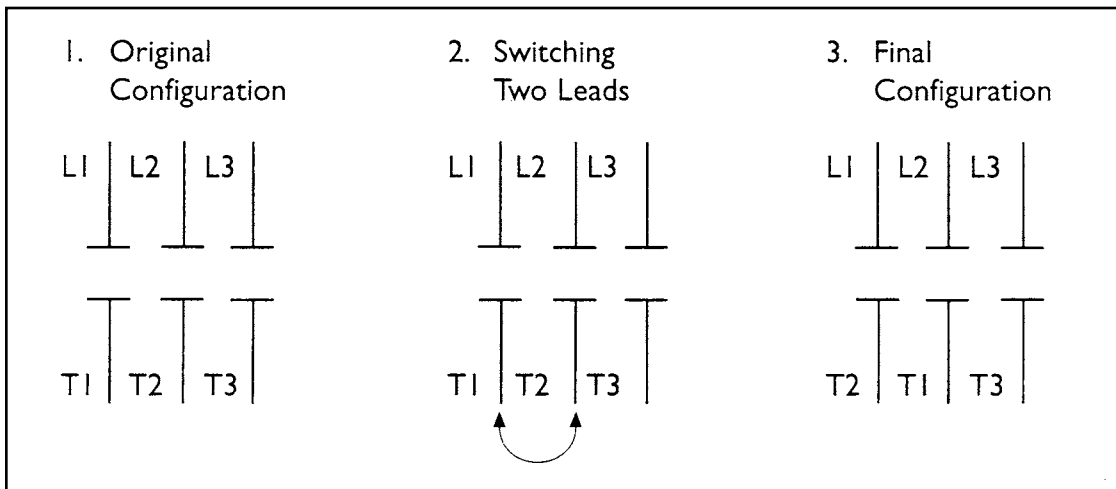

Figure 3.6
Changing Motor Rotation

STEPS

- A. Start the pump and note the pressure and flow rate developed at the pump discharge.
- B. Stop the pump and interchange any of the two leads (Figure 3.6, Changing Motor Rotation).
- C. Start the pump again and re-check the flow rate and pressure.
- D. Compare the results observed. The wire connection that yielded the highest pressure and flow rate is the proper connection. Interchange the two leads again only if necessary.

3.6.3 Three-Phase Power Imbalance

Current imbalance should not exceed 5% of the average three-phase current. The current imbalance can be calculated as follows:

STEPS

1. Measure the current through each of the three legs.
2. Determine the average of the three currents.
3. Determine the difference between the current in each leg and the average of all three legs.
4. Take the difference with the largest value, and divide it by the average current. Multiply by 100 to obtain the current imbalance percentage.
5. If the current imbalance is greater than 5%, "roll" the leads and re-test (Figure 3.7, "Rolling" the Leads to Balance Current Draw). If "rolling" the leads does not correct the problem, the source of the imbalance must be located and corrected. For more information on current imbalance, refer to the motor operation manual.

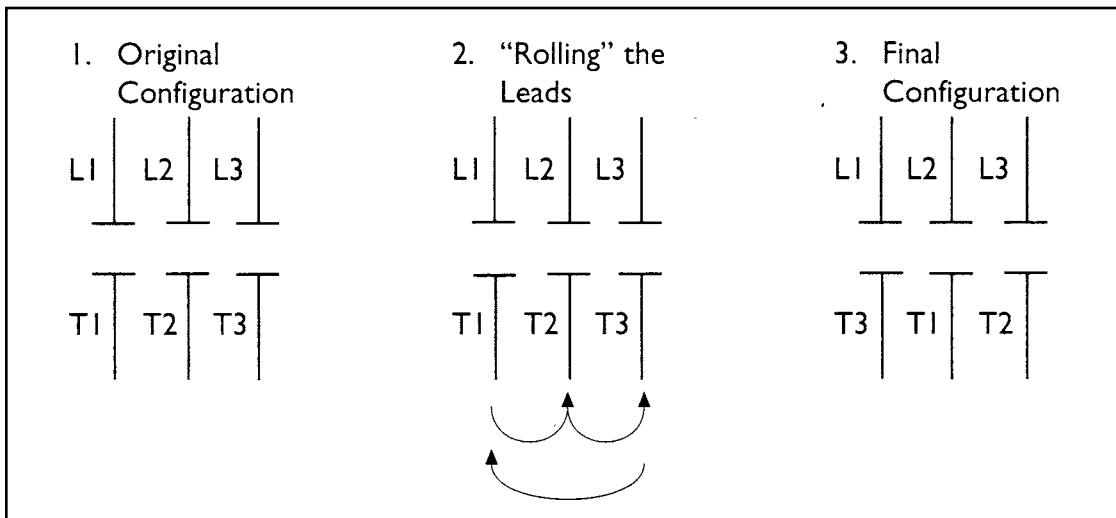

Figure 3.7
"Rolling" the Leads to
Balance Current Draw

3.6.4 Wire Sizing

For correct power lead sizing from the power source to controls and motor, refer to the motor installation manual or local electrical codes.

3.7 Electrical Grounding

WARNING: ELECTRICALLY GROUND THIS UNIT PRIOR TO START-UP.

Failure to do so may result in serious injury or death!

Verify there is electrical continuity between the motor module and the junction box using a volt-ohm meter (Figure 2.1, Pump and Motor Labels). The junction box must be grounded to an earth ground following local electrical codes. Grounding lugs are provided within the junction box for this purpose. Check the continuity of your ground connection to the motor module using a volt-ohm meter.

The motor module flange may also be directly connected to an earth ground.

3.8 Motor Protection - IMPORTANT!

Warranty on the flow-cooled motor is void unless proper quick-trip ambient compensated protection is used on all three motor lines. Subtrol may be used on pumps with Franklin Motors. Refer to the motor installation manual.

4.0 PUMP OPERATION

Review Section 2.0 (Tonkaflo Specifications) and Section 3.0 (Pump Installation) before operating your pump.

4.1 Priming

Prime the pump as noted in Section 3.5 (Pump Priming).

4.2 Operation

Operate the pump within its specified flow range. Failure to do so may damage the motor or liquid end. Refer to the Performance Specifications (Section 2.2) or the performance curve supplied with your pump.

CAUTION: **Do not run pump dry or without sufficient heads.**
The pump shall not be operated with an inlet pressure less than 20 psi (1.4 bar).

Do not deadhead pump.

The pump shall not be operated below the minimum or above the maximum capacity specified for your particular model (Table 2.1, Pump Performance Summary).

Do not exceed 90°F (32°C) operating fluid temperature.

The pump may be flushed with sanitizing water provided no power is supplied to the motor.

4.3 Restarts - IMPORTANT!

A maximum of 100 starts per day is recommended

Motors should be allowed to run one minute to dissipate heat build-up from starting current

5.0 GENERAL TROUBLESHOOTING

This troubleshooting guide can assist you in identifying common operating problems you may experience with your machine. The operator can easily correct many of these problems, however, for those that persist or are not understood you should contact the GE Customer Support Center. Have the following information available when calling the Customer Support Center:

1. Machine installation date
2. Model number
3. Serial number
4. Detailed description of problem.

TROUBLESHOOTING GUIDE		
PROBLEM	POSSIBLE CAUSES	REMEDIES
Low flow	Restrictions in the inlet or discharge	The pump inlet should be piped to induce minimal pressure drops through piping diameter changes, elbows, instrumentation, etc. QSV pumps should NEVER be throttled at the inlet. Check discharge screen for obstructions.
	Inlet strainer/filter plugged	Verify no debris is clogging screen or filter.
	Discharge throttling valve closed (pump deadheaded)	Make sure the discharge valve is open enough to keep the pump running on the performance curve.
	Air leak in inlet piping	Fluid motion in your inlet piping may draw air into the pump if the piping is not sealed properly. Air bubbles will be visible in the discharge line.

TROUBLESHOOTING GUIDE		
PROBLEM	POSSIBLE CAUSES	REMEDIES
Low flow (continued)	Suction lift too high	QSV pumps are not designed to “lift” or “pull” fluid from a tank. QSV pumps must be fed with positive pressure [at least 20 psi (1.4 bar)]. This may be accomplished either by having positive head from the tank or incorporating a transfer pump.
	Reverse rotation of motor	Make sure the motor is spinning in the proper direction.
	Pump not adequately primed	Prime the pump by filling all inlet piping, including the pump, with the process fluid.
	Excessive flow	Make sure your pump is operating within the flow range specified by the pump performance summary table or the performance curve included with the pump.
	Clogged suction into filter or screen	Verify no debris is clogging the inlet screen or filter.
	Air leak in the inlet piping	Fluid motion in your inlet piping may draw air into the pump if the piping is not sealed properly. Air bubbles will be visible in the discharge line.
	Reverse rotation of motor	Make sure the motor is spinning in the proper direction. Reverse two of the leads if necessary.

TROUBLESHOOTING GUIDE		
PROBLEM	POSSIBLE CAUSES	REMEDIES
Motor does not run	Blown fuse, tripped circuit breaker or overloaded	Verify the fuses are not blown, a circuit breaker has not tripped (also check the breaker for controls), and the heaters are not overloaded. The wiring, heater switches and starter must be inspected for possible damage prior to starting.
	Line voltage connection different from motor voltage	Make sure the motor is wired across the proper voltage. The required voltage is indicated on the motor label.
	Bad connection	With the circuit de-energized, check for continuity using an ohmmeter.
	Motor wired improperly	Confirm the circuit is wired for single-phase or three-phase and the motor is grounded.
	Shut-off controls disabling circuit.	Check safety shut-off circuitry to make sure the necessary circuit by-passes are in place to start the motor.
	Single-phase motor controller not operational	Check single-phase motor controller and verify that it is in working order. See detailed label inside controller box.
Motor runs, then stops	Motor exceeding rated amp draw	Check the amp draw through each leg leading to the motor using an ammeter. The readings should not exceed the maximum amps (S.F.A.) indicated on the motor label.

TROUBLESHOOTING GUIDE		
PROBLEM	POSSIBLE CAUSES	REMEDIES
Motor runs, then stops (continued)	Motor starter heater size too small	Measure the current draw to verify it is below the trip setting. Increase the heater size or adjust the trip setting to correspond to the S.F.A. indicated by the motor label.
	Specify gravity of liquid or viscosity greater than design	QVS pumps are designed to pump water. Consult the factory for liquids other than water.
	Water short in motor electrical lead	With the pump filled with the process fluid, use a megohm meter to measure the resistance between each motor lead and ground first at low voltage, then at a potential between 500 and 1000V if the low-voltage test indicates an open circuit. Consult the motor installation and maintenance manual for acceptable values.
	Bad connection	With the circuit de-energized, check for continuity using an ohmmeter.
	Motor wired improperly	Confirm the circuit is wired for single-phase or three-phase power and the motor is grounded.
	Three-phase current imbalance	Make sure the three legs of your three-phase power are balanced within $\pm 5\%$ of each other.

TROUBLESHOOTING GUIDE		
PROBLEM	POSSIBLE CAUSES	REMEDIES
Pump/motor vibrates	Improper mounting	Confirm both the pump liquid end and motor module are firmly secured to a rigid structure.
	Starved suction line	QSV pumps must be fed with positive pressure [at least 20 psi (1.4 bar)]. Check to make sure there are no obstructions, constrictions, high points, or clogged filters ahead of the pump.
	Operating off the performance curve	QSV pumps must operate in the flow range specified by the performance summary table or the pump performance curve.
Pump leaks	Piping not properly sealed	Seal threaded fittings with Teflon tape. Make sure gaskets are properly seated in Victaulic or flanged fittings.
	O-rings in pump casing or motor module damaged	Replace the O-ring if possible, or return the pump to the factory for repair.

6.0 FIELD MAINTENANCE

6.1 Flow-Cooled Motor and Liquid End - Tonkaflo Service Policy

WARNING: **FIELD SERVICE OF THE FLOW-COOLED MOTOR OR LIQUID IS NOT RECOMMENDED.** If a liquid end is damaged by running the pump dry, inadequate flow, deadheading, cavitation or other reasons, return it with the motor to the factory for repair. The motor module and liquid end may be separated for easier shipping. See Section 6.2 (Liquid End Removal and Installation) for liquid end removal.

If a repair at the factory is desired, call the factory for a Return Goods Authorization (RGA) number and follow the directions provided by a GE Customer Service representative. See Section 7.0 [Return Goods Authorization (RGA) Procedure] for more details.

6.2 Liquid End Removal and Installation

WARNING: **DISCONNECT POWER SOURCE BEFORE ATTEMPTING ANY TYPE OF FIELD SERVICE. FAILURE TO DO SO MAY RESULT IN SERIOUS INJURY OR DEATH!**

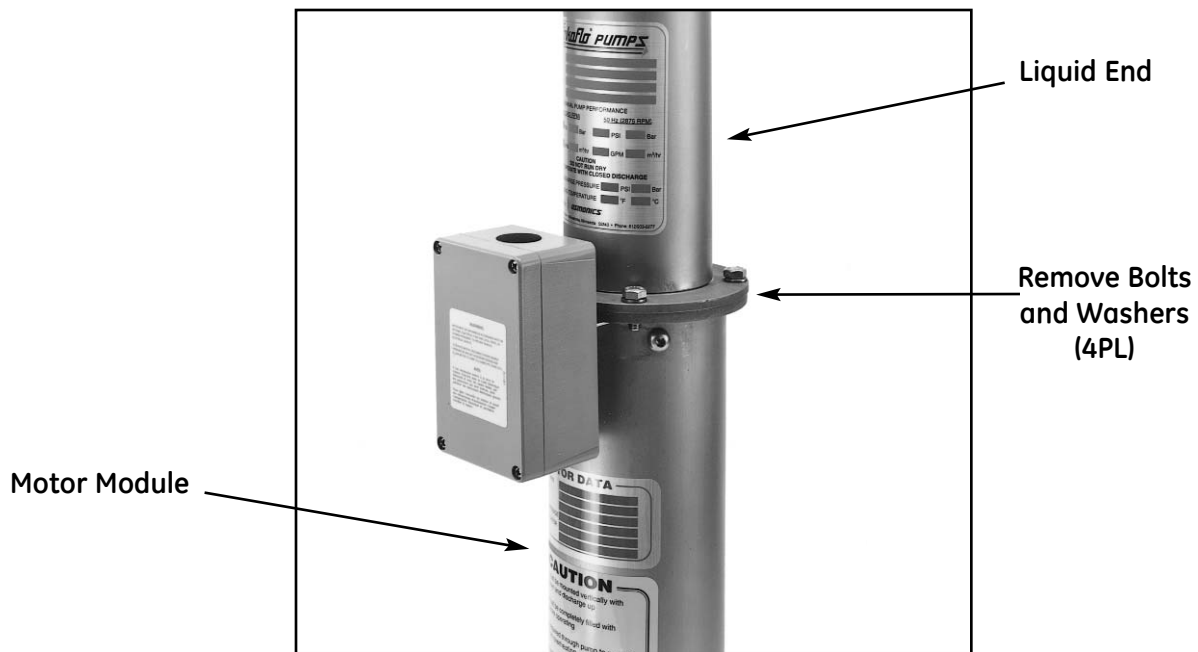

Figure 6.8
Liquid End and
Motor Module
(QS2825V Shown)



Figure 6.9
Removing Liquid End
(QS2825V Shown)

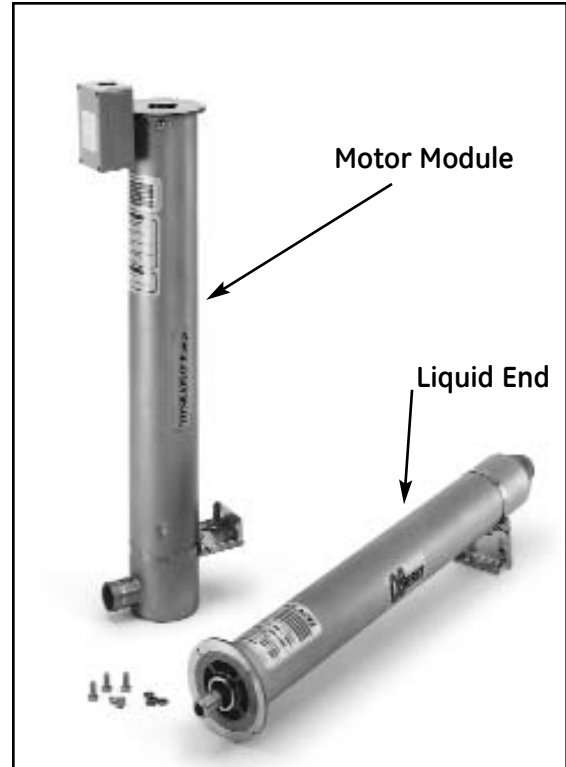

Figure 6.10
Liquid End Removal
(QS2825V Shown)

To separate the liquid end from the motor module, simply remove the four bolts joining the two together (Figure 6.8, Liquid End and Motor Module) and carefully pull them apart (Figure 6.10, Liquid End Removal). To rejoin the liquid end to the motor module, use the following procedure: (Figures 6.9 and 6.10 detail the components and assembly).

STEPS

1. Lubricate the O-ring with petroleum or silicone grease
2. Align the splines on the liquid end coupling to the splines on the motor, and join together using the four cap screws and lock washers. Do not over-tighten.

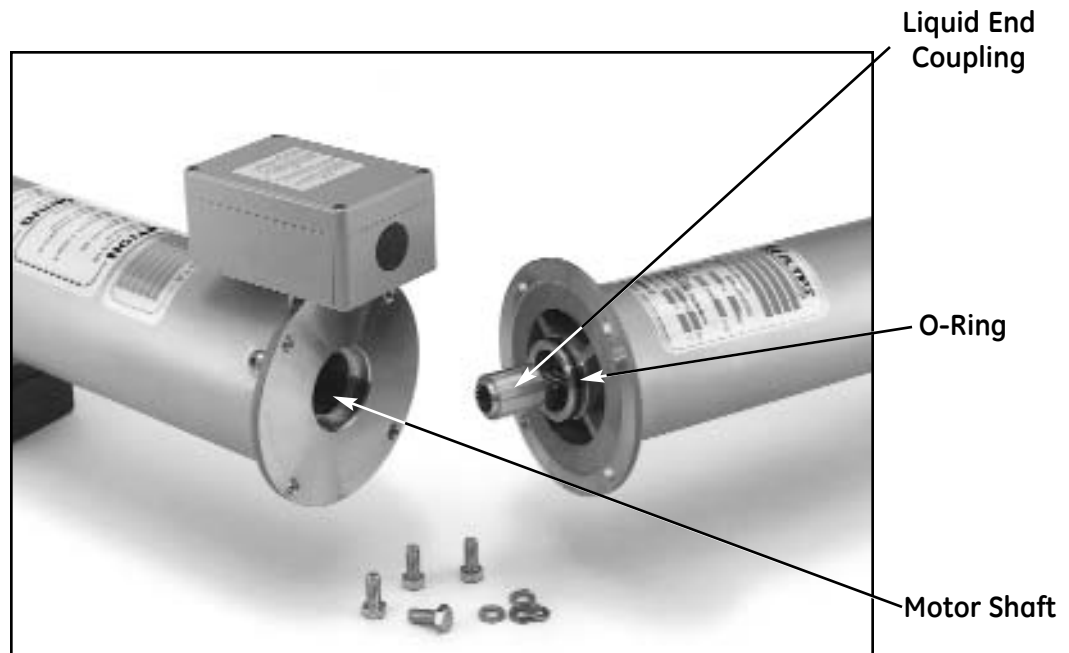

Figure 6.11
Component Detail
(QS2825V Shown)

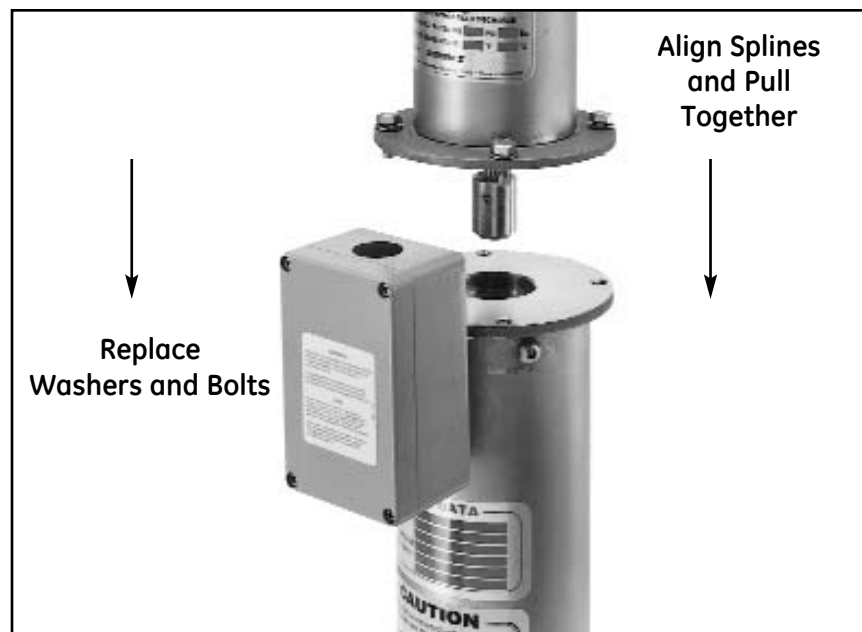

Figure 6.12
Rejoining Liquid End
to Motor Module
(QS2528V Shown)

7.0 TONKAFLO PUMP RETURN GOODS AUTHORIZATION (RGA) PROCEDURE

If you wish to return goods for repair, warranty evaluation and/or credit, please have your original sales order or invoice available when you call GE. Call (800) 848-1750 and ask to speak with Customer Service. A Customer Service representative will provide instructions and a Return Goods Authorization (RGA) number which needs to be clearly written on the outside of the box used to ship your materials. All equipment must be shipped to GE with the freight prepaid by the customer. Call our Customer Service Center with any questions or issues concerning freight claims and a representative will discuss your situation.

All materials to be returned must be rendered into a non-hazardous condition prior to shipping.

There are two ways to handle a return: (1) send in the pump for repair and return or (2) purchase a new pump and when desired, send the defective pump to the factory for repair and return.

7.1 Motor Warranty

Motors must be sent to the nearest authorized motor service center for repair, replacement, and warranty disposition.

7.2 In-Warranty Pump Failure

7.2.1 Return the defective pump to the factory for repair on an RGA within fifteen (15) days. GE absorbs the cost of repair. The repaired pump will be returned and remains under warranty for the remainder of the original warranty period or three months, whichever is longer.

7.2.2 GE will not restock or issue return credit against a new, non-stock, pump purchase regardless of the warranty status of the failed pump. The warranty (Section 10.0) is 12 months from installation or 15 months from receipt, whichever occurs first.

7.3 Out-of-Warranty Pump Failure

Return the pump on an RGA for repair. The pump will be repaired and repair charges invoiced to the customer. The warranty on repairs is three months.

7.4 Shipping Charges

7.4.1 In-Warranty

Customer pays for shipment to GE. GE pays one way surface freight return to customer.

7.4.2 Out-of-Warranty When New Pump is Purchased

Customer pays all shipping charges.

8.0 DIMENSIONAL DRAWING

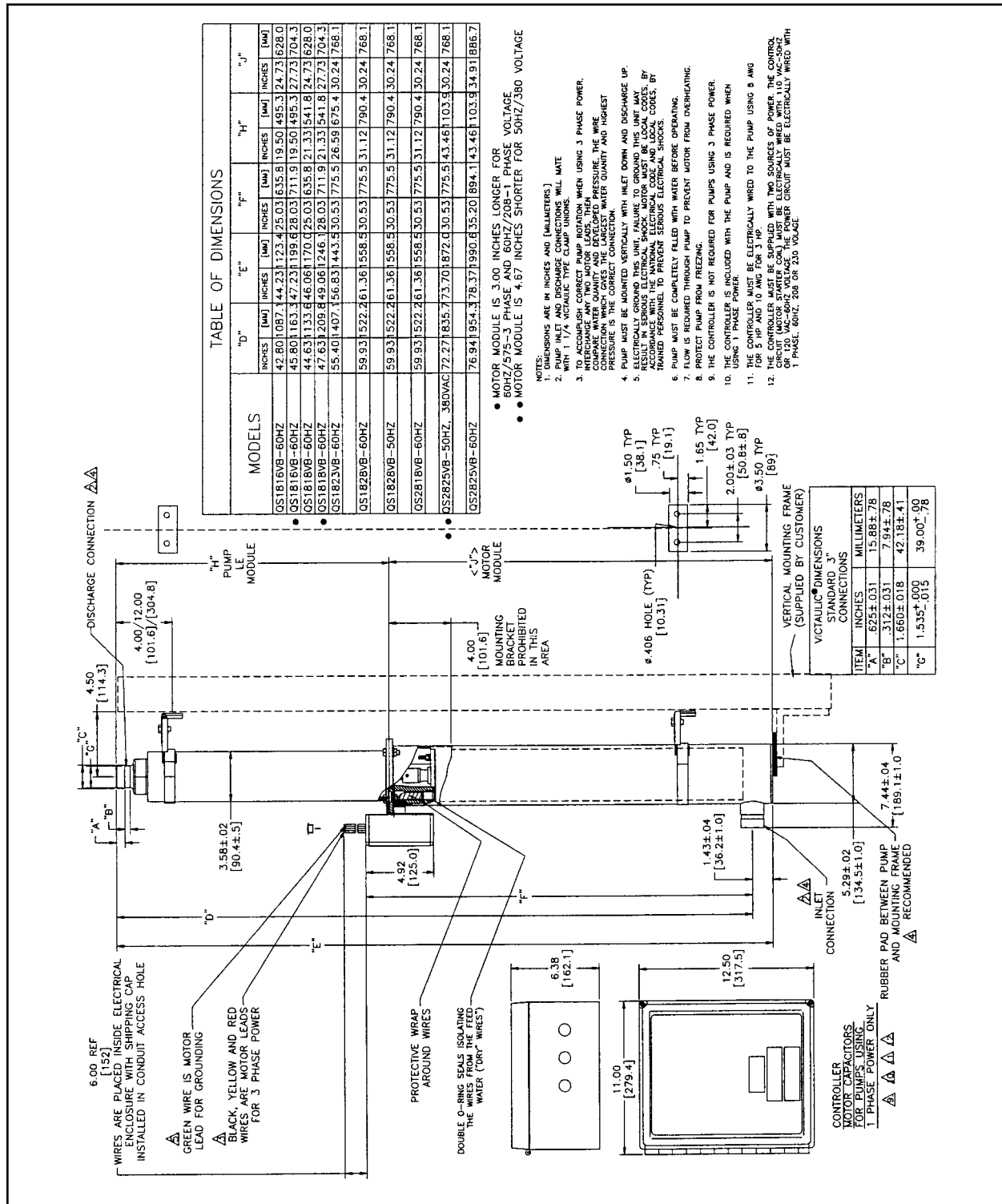

Figure 8.13
QS1800V and
QS2800V Series

9.0 REPLACEMENT PARTS

9.1 Parts Schematic

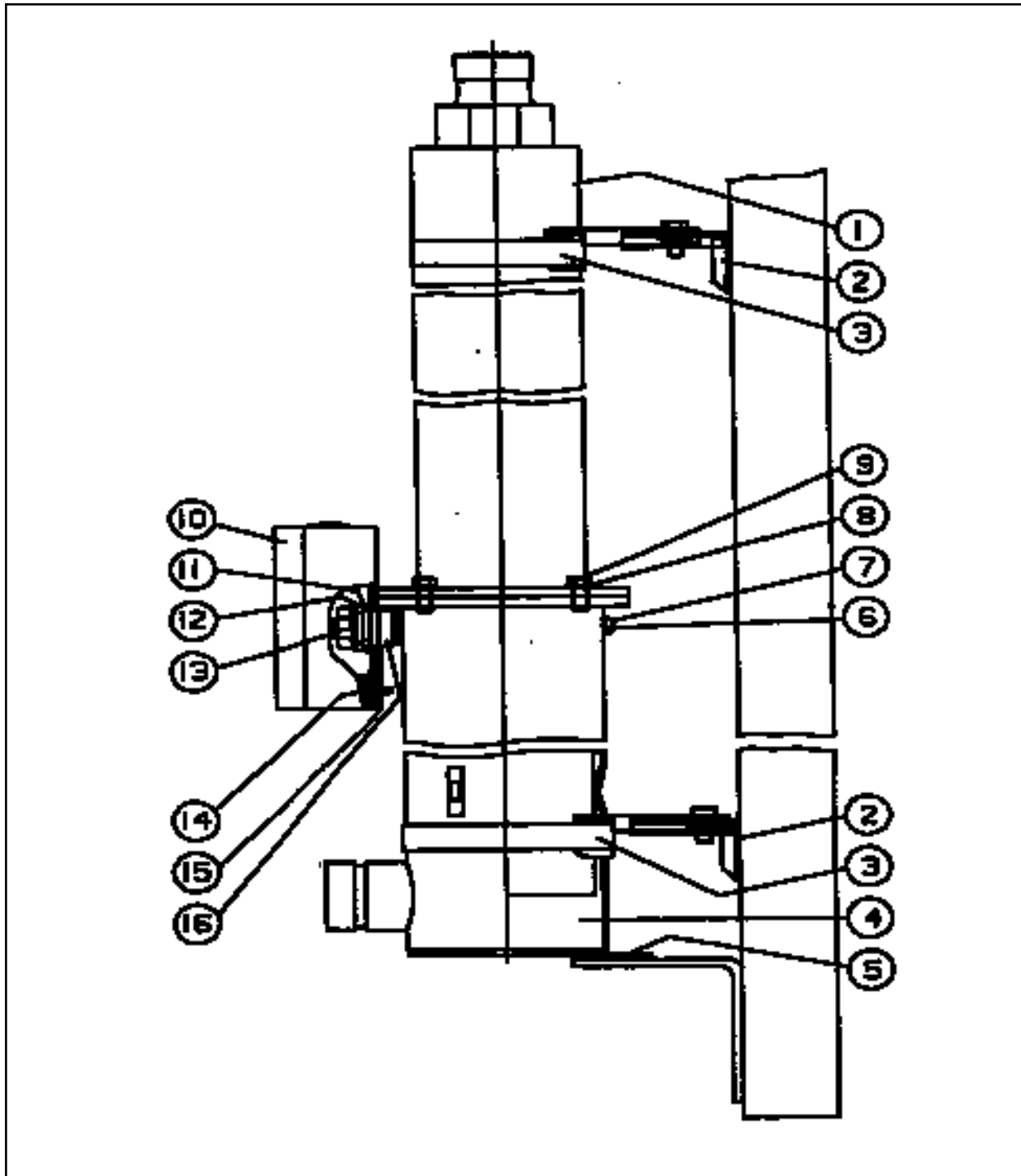

Figure 9.14
Parts Schematic

9.2 Parts List, Standard Models

Item Number	Part Description	QS1800V QS2800V Part Number
1	Liquid End Module	*
2	Shell Support Assembly	1125211
3	Clamp	1122861
4	Motor Module	*
5	Rubber Pad	1125199
6	Lock Washer	1149629
7	Screw	1123200
8	Lock Washer	1149629
9	Screw, Cap, Hex	1156215
10	Electrical Enclosure	1125267
11	Gasket	1112276
12	Nut, Electrical	1111878
13	Nut, PVC	1125312
14	Screw	1158439
15	Bracket	1125268
16	Nipple Assembly	1125313

* Specify pump model.

9.3 Accessories for QS Series Tonkaflo Pumps

Part Number	Part Description
1110597	Victaulic Coupling, 1.25-inch (31.8 mm), Style 77, Buna-N
1113653	Adapter, 1.25-inch (318. mm), Victaulic x 1.25-inch (31.8 mm), FNPT, 316SS
1120797	Adapter, 1.25-inch (318. mm), Victaulic x 1.0-inch (25.4 mm), FNPT, 316SS
1120229	Adapter, 1.25-inch (318. mm), Victaulic x 0.75-inch (19.1 mm), FNPT, 316SS
1120264	Pump Discharge Screen
1123394	QS Series Operation and Maintenance Manual

9.4 Ordering Parts

Order parts through your local distributor or directly from:

GE Infrastructure
Water & Process Technologies

5951 Clearwater Drive
Minnetonka, MN 55343-8995
USA

Phone: (952) 933 - 2277
Fax: (952) 933 - 0141
Toll Free: (800) 848 - 1750

To order parts, the following information is necessary:

1. Pump model number
2. Pump serial number (from nameplate)
3. Other nameplate information, such as, operating temperature or material code, and type of mechanical seal
4. Motor horsepower, motor frame size, and enclosure specifications
5. Part name
6. Part number
7. Quantity desired
8. Special materials of construction, if any.

10.0 WARRANTY

GE warrants its pumps to be free from defects in design, material, or workmanship for a period of 15 months from receipt or 12 months from installation of the product, whichever occurs first, when said products are operated in accordance with written instructions and are installed properly. If Tonkaflo pumps are altered or repaired without prior approval of GE, all warranties are void. If any defects or malperformance occur during the warranty period, GE's sole obligation shall be limited to alteration, repair or replacement at GE's expense, F.O.B. factory, of parts or equipment which, upon return to GE and upon GE's examination, prove to be defective. Equipment and accessories not manufactured by GE are warranted only to the extent of and by the original manufacturer's warranty. GE shall not be liable for damage or wear to equipment caused by abnormal conditions, excessive temperatures, vibration, failure to properly prime or to operate equipment without flow, or caused by corrosives, abrasives or foreign objects. The foregoing warranty is exclusive and in lieu of all other warranties, whether expressed or implied including any warranty of merchantability or fitness for any particular purpose. In no event shall GE be liable for consequential or incidental damages.

PUMP MODEL NUMBER: _____

PUMP SERIAL NUMBER: _____

For more information call 952-933-2277 or 800-848-1750 in the U.S., or visit www.gewater.com.

GE Infrastructure Water & Process Technologies

North American Sales

5951 Clearwater Drive
Minnetonka, MN
55343-8995
USA
(952) 933-2277 Phone
(952) 933-0141 Fax

Euro/Africa Sales

230 rue Robert Schurman
ZA des Uselles
77350 Le Mée sur Seine
FRANCE
+33 1 64 10 2000 Phone
+33 1 64 10 3747 Fax

Asia/Pacific Sales

1044/8 SOI 44/2
Sukhumvit Road Parkanog
Bangkok 10110
THAILAND
+66 2 38 14213 Phone
+66 2 39 18183 Fax



Free Manuals Download Website

<http://myh66.com>

<http://usermanuals.us>

<http://www.somanuals.com>

<http://www.4manuals.cc>

<http://www.manual-lib.com>

<http://www.404manual.com>

<http://www.luxmanual.com>

<http://aubethermostatmanual.com>

Golf course search by state

<http://golfingnear.com>

Email search by domain

<http://emailbydomain.com>

Auto manuals search

<http://auto.somanuals.com>

TV manuals search

<http://tv.somanuals.com>