

Use and Care Guide

Refrigerator



Safety Instructions 3



Operating Instructions, Tips

Appliance Registration.....	2
CFC Disposal.....	2
Operating Your Refrigerator.....	3, 4



Care and Cleaning.....4



Preparation

Clearances.....	5
Location.....	2, 5
Vacation and Moving Precautions.....	5



Problem Solver 9

More questions...call
GE Answer Center® 800.626.2000



Installation..... 6-8

Adapter Plug.....	6
Electrical Requirements.....	6
Extension Cord.....	6
Grounding.....	6
Reversing the Door Swing.....	7, 8



Consumer Services..... 10, 11

Model and Serial Numbers.....	2
Repair Service.....	2
Warranty.....	Back Cover

Models: SC4 TAX4

GE Quality Product



HELP US HELP YOU...

Read this guide carefully.

It is intended to help you operate and maintain your new refrigerator properly.

Keep it handy for answers to your questions.

If you don't understand something or need more help, call:

GE Answer Center®

800.626.2000

24 hours a day, 7 days a week

Keep proof of original purchase date (such as your sales slip or cancelled check) with this guide to establish the warranty period.

Write down the model and serial numbers.

You'll find them on a plate located at the top outside rear corner of the refrigerator.

These numbers are also on the Consumer Product Ownership Registration Card that came with your refrigerator. Before sending in this card, please write these numbers here:

Model Number

Serial Number

Use these numbers in any correspondence or service calls concerning your refrigerator.

If you received a damaged refrigerator, immediately contact the dealer (or builder) that sold you the refrigerator.

Save time and money. Before you call for service, check the Problem Solver. It lists causes of minor operating problems that you can correct yourself.

CFC DISPOSAL

Your old refrigerator has a cooling system that used CFCs (chlorofluorocarbons). CFCs are believed to harm stratospheric ozone.

If you are throwing away your old refrigerator, make sure the CFC refrigerant is removed for proper disposal by a qualified servicer. If you intentionally release this CFC refrigerant you can be subject to fines and imprisonment under provisions of the federal Clean Air Act.

IF YOU NEED SERVICE

We're proud of our service and want you to be pleased. If for some reason you are not happy with the service you receive, here are three steps to follow for further help.

FIRST, contact the people who serviced your appliance. Explain why you are not pleased. In most cases, this will solve the problem.

NEXT, if you are still not pleased, write all the details—including your phone number—to:

Manager, Consumer Relations
GE Appliances
Appliance Park
Louisville, Kentucky 40225

FINALLY, if your problem is still not resolved, write:

Major Appliance
Consumer Action Program
20 North Wacker Drive
Chicago, Illinois 60606

IMPORTANT SAFETY INSTRUCTIONS

Read All Instructions Before Using This Appliance.



⚠ WARNING—When using this appliance, always exercise basic safety precautions, including the following:

- **Use this appliance only for its intended purpose** as described in this Use and Care Guide.

- **This refrigerator must be properly installed in accordance with the Installation Instructions before it is used.** See grounding instructions in the Installation section.

- **Never unplug your refrigerator by pulling on the power cord.** Always grip plug firmly and pull straight out from the outlet.

- **Repair or replace immediately all electric service cords that have become frayed or otherwise damaged.** Do not use a cord that shows cracks or abrasion damage along its length or at either the plug or connector end.

- **When moving your refrigerator away from the wall, be careful not to roll over or damage the power cord.**

- **Do not allow children to climb, stand or hang on the shelves in the refrigerator.** They could damage the refrigerator and seriously injure themselves.

- **If your old refrigerator is still around the house, but not in use, be sure to remove the doors.** This will reduce the possibility of danger to children.

- **After your refrigerator is in operation, do not touch the cold surfaces, particularly when hands are damp or wet.** Skin may adhere to these extremely cold surfaces.

- **Don't refreeze frozen foods which have thawed completely.** The United States Department of Agriculture in Home and Garden Bulletin No. 69 says:

“... You may safely refreeze frozen foods that have thawed if they still contain ice crystals or if they are still cold—below 40°F.

“... Thawed ground meats, poultry or fish that have any off-odor or off-color should not be refrozen and should not be eaten. Thawed ice cream should be discarded. If the odor or color of any food is poor or questionable, get rid of it. The food may be dangerous to eat.

“... Even partial thawing and refreezing reduces the eating quality of foods, particularly fruits, vegetables and prepared foods. The eating quality of red meat is affected less than that of many other foods. Use refrozen foods as soon as possible to save as much of their eating quality as you can.”

- **Unplug your refrigerator before cleaning and making repairs. NOTE:** We strongly recommend that any servicing be performed by a qualified individual.

- **Do not store or use gasoline or other flammable vapors and liquids in the vicinity of this or any other appliance.**

SAVE THESE INSTRUCTIONS

OPERATING YOUR REFRIGERATOR



Temperature Control Dial

The temperature control dial has settings from “1” to “9” plus “OFF”. “1” is the warmest. “9” is the coldest. Initially set the temperature control dial at “5”. After using the refrigerator for 24 hours, adjust the temperature control to the setting that is best suited to your needs.

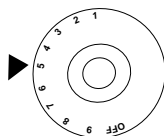
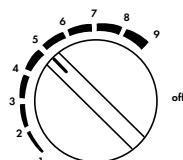

Your temperature control dial will look like one of the dials above.

NOTE:

- **If this refrigerator is unplugged or turned off, you must allow 3 minutes before starting it or plugging it back in. If you attempt to restart it in less than 3 minutes, it will not start.**
- **Turning the temperature control dial to “OFF” stops cooling but does not shut off power to the refrigerator.**

(continued next page)



OPERATING YOUR REFRIGERATOR

(continued)

Ice Service

Ice trays need to be set on the floor of the ice tray compartment to freeze properly.

To release ice cubes, hold the tray upside down over an ice bucket or bowl and twist tray at both ends.

If the ice tray freezes to the floor, pour a little lukewarm water around it to loosen it. Do not use boiling water which can damage plastic parts, or sharp metal objects such as a knife or screwdriver which can damage the cooling system tubing.

Wash ice trays in lukewarm water only. Do not put them in an automatic dishwasher.

Ice Tray Compartment

- This compartment is designed for production of ice cubes and short-term storage (a few days at the most) of some commercial-frozen foods.
- The temperature in the ice tray compartment doesn't get cold enough to freeze food safely.



CARE AND CLEANING

Cleaning Inside—Outside

Unplug the refrigerator and remove food, shelves and trays. Wash inside with warm water and baking soda solution—about two tablespoons of baking soda to a quart of water. Then rinse and dry.

Don't use cleansers such as soaps, detergents, scouring powder or spray cleaners—they may cause odors inside the refrigerator.

Wash ice cube trays, drip tray and shelves in mild detergent solution and dry with a soft cloth.

To help prevent odors, leave an open box of baking soda in the rear of the refrigerator, on the shelf. Change the box every three months.

Wipe outside of refrigerator with a soft cloth dampened with soapy water or Appliance Polish Wax Cleaner, available from GE Appliance Service and Parts Centers. Use only mild, soapy water to clean the door gasket.

Never use acids, chemical thinner, gasoline, benzine or the like for cleaning any part of the refrigerator. Boiling water or benzine may deform or damage plastic parts.

Do not wash any plastic parts from your refrigerator in your automatic dishwasher.

Defrosting

Defrost whenever frost on the wall of the ice tray compartment becomes 1/4" thick.

Never use a sharp or metallic instrument to remove frost as it may damage the cooling coils. (A punctured cooling coil will cause serious problems and void the warranty.) We recommend using a plastic scraper.

Do not use any electrical device in defrosting your refrigerator.

To defrost, remove foods and ice trays from the ice tray compartment, put drip tray in place, and set temperature control dial at "OFF".

Defrosting usually takes a few hours. To defrost faster, keep the door open. Also, pouring warm (not hot) water on the frosted part may speed defrosting. **Do not use boiling water**—it may damage plastic parts.

After defrosting, empty water from the drip tray. Wash the drip tray in warm water. Wipe the ice tray compartment with a damp cloth. Then turn the temperature control to the desired setting and return food and ice trays to the refrigerator.

NOTE: If ice buildup is very thick, it may keep the ice tray compartment door from opening or closing completely. Don't try to force it open; after defrosting, the door will open and close easily.

PREPARATION



Location

The refrigerator must be installed on a floor strong enough to support it when fully loaded.

If the refrigerator is in a 40°F. or colder room, it will operate but it will not cool foods properly.

Clearances

Allow the following clearances for ease of installation, door opening and proper air circulation:

- Top.....12"
- Back.....5"
- Sides 1/2"

When You Move

Disconnect the power cord from the wall outlet, remove food and defrost refrigerator. Then clean and dry the interior.

Secure all loose items such as ice trays and drip tray by taping them securely in place to prevent damage.

Be sure refrigerator stays in upright position during actual moving and in van. Refrigerator must be secured in van to prevent movement. Protect outside of refrigerator with blanket.

When you go on Vacation

For extended vacations or absences, unplug the refrigerator. Clean the interior with a baking soda solution of one tablespoon of soda to one quart of water. Wipe dry. To prevent odors, leave an open box of baking soda in the refrigerator. Leave doors open.

For shorter vacations, remove perishable foods and leave the control at regular setting. However, if room temperature is expected to drop below 40°F. follow the same instructions as for extended vacations.

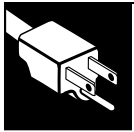

INSTALLATION REQUIREMENTS

IMPORTANT...Please read carefully

How to Connect Electricity

For personal safety, this appliance must be properly grounded.

The power cord of this appliance is equipped with a three-prong (grounding) plug which mates with a standard three-prong (grounding) wall outlet (Fig. 1) to minimize the possibility of electric shock hazard from this appliance.

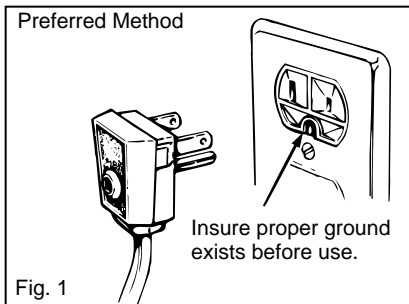

Have wall outlet and circuit checked by a qualified electrician to make sure the outlet is properly grounded.

Where a standard two-prong wall outlet is encountered, it is your personal responsibility and obligation to have it replaced with a properly grounded three-prong wall outlet.

DO NOT, UNDER ANY CIRCUMSTANCES, CUT OR REMOVE THE THIRD (GROUND) PRONG FROM THE POWER CORD.

Use of Adapter Plug

Because of potential safety hazards under certain conditions, we strongly recommend against use of an adapter plug. However, if you still elect to use an adapter, where local codes permit, a **TEMPORARY CONNECTION** may be made to a properly grounded two-prong wall outlet by use of a UL listed adapter (Fig. 2) available at most local hardware stores.

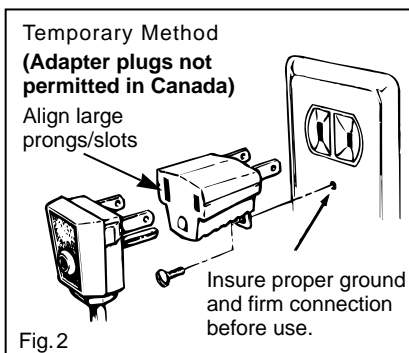

The larger slot in the adapter must be aligned with the larger slot in the wall outlet to provide proper polarity in the connection of the power cord.

CAUTION: Attaching adapter ground terminal to wall outlet cover screw does not ground the appliance unless cover screw is metal, and not insulated, and wall outlet is grounded through house wiring. You should have the circuit checked by a qualified electrician to make sure the outlet is properly grounded. When disconnecting the power cord from the adapter, always hold the adapter with one hand. If this is not done, the adapter ground terminal is very likely to break with repeated use. Should the adapter ground terminal break, **DO NOT USE** the appliance until a proper ground has been established.

Use of Extension Cords

Because of potential safety hazards under certain conditions, we strongly recommend against the use of an extension cord. However, if you still elect to use an extension cord, it is absolutely necessary that it be a UL listed 3-wire grounding type appliance extension cord having a grounding type plug and outlet and that the electrical rating of the cord be 15 amperes (minimum) and 120 volts.

Electrical Requirements

The refrigerator should always be plugged into its own individual electrical outlet which has a voltage rating that matches the plate.

This provides the best performance and also prevents overloading house wiring circuits which could cause a fire hazard from overheated wires.

REVERSING THE DOOR SWING

(on some models)

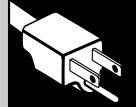

TO CHANGE THE DOOR SWING DIRECTION

Carefully set the refrigerator on its left side.

Remove the leveling leg below the bottom hinge and the leveling leg at the opposite corner.

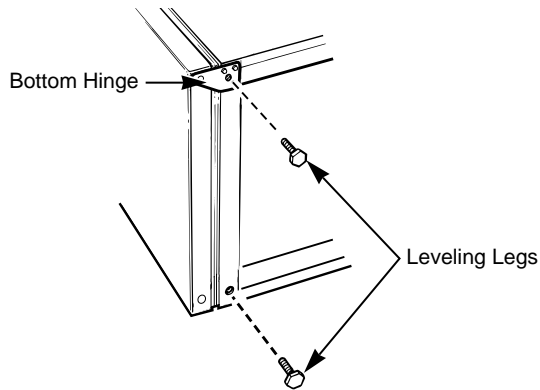

Remove the bottom hinge. Set the door aside. Remove the two screws from the other side of the case bottom.

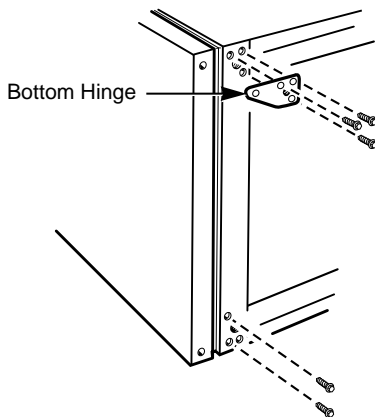

Remove the three screws that hold the top in place.

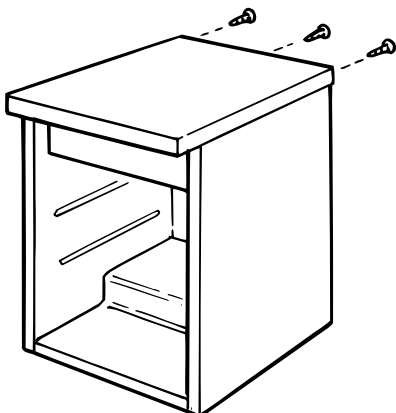

Slide back the top just enough to have access to the screws.

Remove the top screw and door pin. Reinstall them on the other side.

Replace the top and three screws.

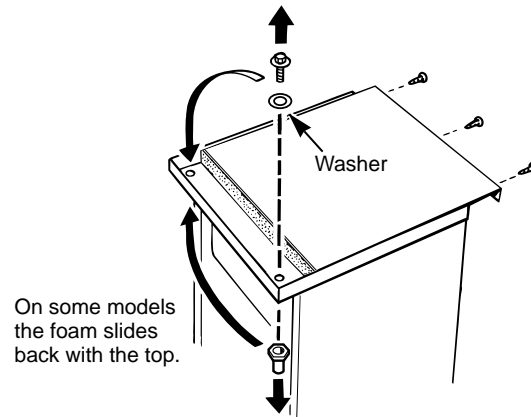

On some models the foam slides back with the top.

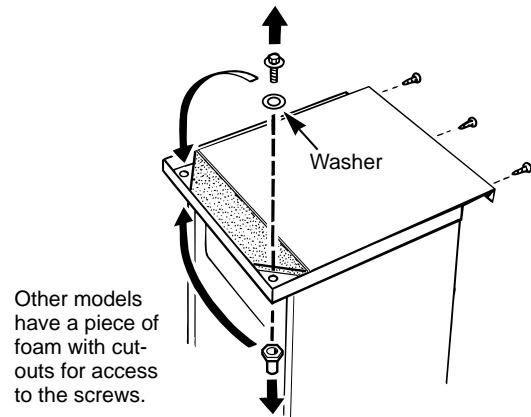

Other models have a piece of foam with cut-outs for access to the screws.

Place the door in position on the top door pin.

Replace the plug button on the other side of the door.

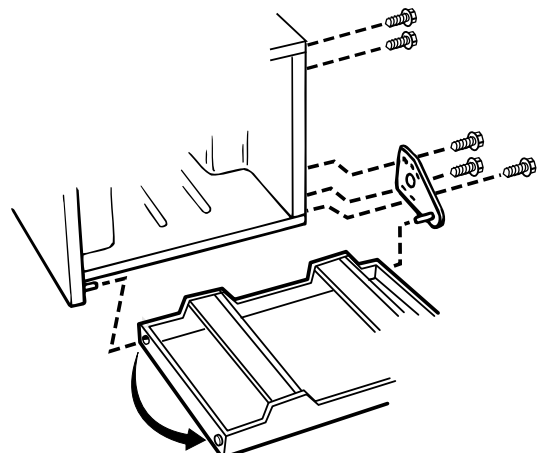

(continued next page)



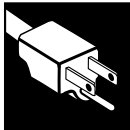

REVERSING THE DOOR SWING

(continued)

Replace the two screws in the other side of the case bottom.

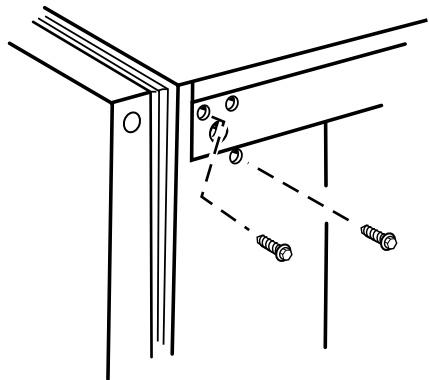

Replace the bottom hinge on the same side as the top door pin.

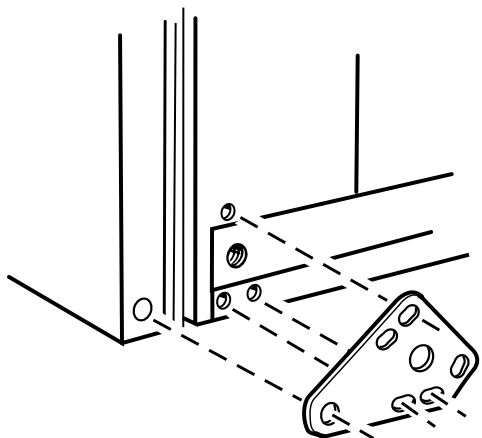

Before tightening the hinge screws, check the gasket. Look at it from both sides to make sure it contacts the cabinet evenly from top to bottom. Push it in if necessary. Also check to insure the door opens and closes without interference. If necessary adjust the position of the bottom hinge.

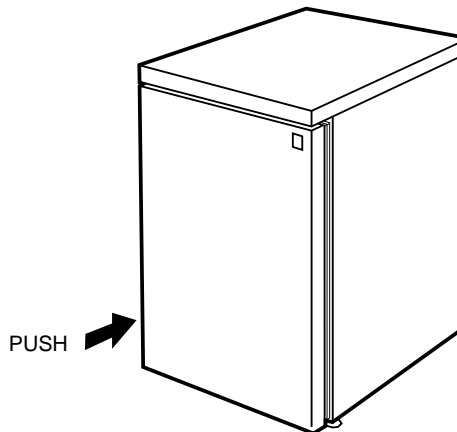

Replace both leveling legs and tighten the hinge screws.

Finished! Enjoy using your refrigerator.

QUESTIONS? USE THIS PROBLEM SOLVER



PROBLEM	POSSIBLE CAUSE
REFRIGERATOR DOES NOT OPERATE	<ul style="list-style-type: none">• Not plugged in.• The circuit breaker tripped, or fuse blown.
TURNS ON AND OFF FREQUENTLY	<ul style="list-style-type: none">• This is normal. Small refrigerators cycle more often than larger ones.
SEEMS TO RUN TOO LONG	<ul style="list-style-type: none">• Check for proper clearances.• Frequent door opening let cold air escape.
VIBRATION	<ul style="list-style-type: none">• If refrigerator vibrates, it probably is not level. Use leveling legs (or shims if necessary) to make it level.
CABINET HAS ODOR	<ul style="list-style-type: none">• Foods with strong odors should be tightly covered.• Check for spoiled food.• Interior may need cleaning. Keep an open box of baking soda in refrigerator and replace every three months.

If you need more help...call, toll free:
GE Answer Center®
800.626.2000
consumer information service

GE Service Numbers



We'll be there!

GE Answer Center®

800.626.2000

Whatever your question about any GE major appliance, GE Answer Center® information service is available to help. Your call—and your question—will be answered promptly and courteously.

And you can call any time. GE Answer Center® service is open 24 hours a day, 7 days a week.

In-Home Repair Service

**800-GE-CARES
(800-432-2737)**

A GE consumer service professional will provide expert repair service, scheduled at a time that's convenient for you. Many GE Consumer Service company-operated locations offer you service today or tomorrow, or at your convenience (7:00 a.m. to 7:00 p.m. weekdays, 9:00 a.m. to 2:00 p.m. Saturdays).

Our factory-trained technicians know your appliance inside and out—so most repairs can be handled in just one visit.

For Customers With Special Needs

800.626.2000

Upon request, GE will provide Braille controls for a variety of GE appliances, and a brochure to assist in planning a barrier-free kitchen for persons with limited mobility. To obtain these items, free of charge, call 800.626.2000.

Consumers with impaired hearing or speech who have access to a TDD or a conventional teletypewriter may call 800-TDD-GEAC (800-833-4322) to request information or service.



Service Contracts

800-626-2224

You can have the secure feeling that GE Consumer Service will still be there after your warranty expires. Purchase a GE contract while your warranty is still in effect and you'll receive a substantial discount. With a multiple-year contract, you're assured of future service at today's prices.

Parts and Accessories

800-626-2002

Individuals qualified to service their own appliances can have parts or accessories sent directly to their home. The GE parts system provides access to over 47,000 parts...and all GE Genuine Renewal Parts are fully warranted. VISA, MasterCard and Discover cards are accepted.

Care and cleaning instructions contained in this manual cover procedures to be performed by any user. Other servicing generally should be referred to qualified service personnel. Caution must be exercised, since improper servicing may cause unsafe operation.

Further Service

We're proud of our service and want you to be pleased. If for some reason you are not happy with the service you receive, here are three steps to follow for further help.

First, contact the people who serviced your appliance. Explain why you are not pleased. In most cases, this will solve the problem.

Next, if you are still not pleased, write all the details—including your phone number—to:

Manager, Consumer Relations
GE Appliances, Appliance Park
Louisville, KY 40225

Finally, if your problem is still not resolved, write:

Major Appliance Consumer
Action Program
20 North Wacker Drive
Chicago, IL 60606

YOUR GE REFRIGERATOR WARRANTY

Staple sales slip or cancelled check here. Proof of original purchase date is needed to obtain service under warranty.

WHAT IS COVERED

LIMITED ONE-YEAR WARRANTY

For one year from date of original purchase, we will provide, free of charge, parts and service labor to repair or replace **any part of the refrigerator** that fails because of a manufacturing defect.

LIMITED ADDITIONAL FOUR-YEAR WARRANTY

For the second through fifth year from date of original purchase, we will provide, free of charge, a **replacement compressor** if the compressor fails because of a manufacturing defect. You pay for any service labor charges.

For each of the above warranties:

You must take the refrigerator to a General Electric Factory Service Center or a General Electric Customer Care® servicer and pick it up following service. In-home service is also available, but you must pay for the service technician's travel costs to your home.

This warranty is extended to the original purchaser and any succeeding owner for products purchased for use in the 48 mainland states, Alaska, Hawaii and Washington, D.C.

All warranty service will be provided by GE Appliance Service and Parts Centers or by our authorized Customer Care® servicers during normal working hours.

Should your appliance need service, during warranty period or beyond, call 800-GE-CARES (800-432-2737).

WHAT IS NOT COVERED

- Service trips to your home to teach you how to use the product.

Read your Use and Care material.

If you then have any questions about operating the product, please contact your dealer or our Consumer Affairs office at the address below, or call, toll free:

GE Answer Center®
800.626.2000
consumer information service

- Improper installation.

If you have an installation problem, contact your dealer or installer.

You are responsible for providing adequate electrical, plumbing and other connecting facilities.

- Replacement of house fuses or resetting of circuit breakers.

- Failure of the product if it is used for other than its intended purpose or used commercially.

- Damage to product caused by accident, fire, floods or acts of God.

- Loss of food due to spoilage.

WARRANTOR IS NOT RESPONSIBLE FOR CONSEQUENTIAL DAMAGES.

Some states do not allow the exclusion or limitation of incidental or consequential damages, so the above limitation or exclusion may not apply to you. This warranty gives you specific legal rights, and you may also have other rights which vary from state to state. To know what your legal rights are in your state, consult your local or state consumer affairs office or your state's Attorney General.

Warrantor: General Electric Company

**If further help is needed concerning this warranty, write:
Manager—Consumer Affairs, GE Appliances, Louisville, KY 40225**

Part No. 162D3917P006
Pub No. 49-6865-3

8-96 CG

SC4
TAX4
Printed in Mexico

Free Manuals Download Website

<http://myh66.com>

<http://usermanuals.us>

<http://www.somanuals.com>

<http://www.4manuals.cc>

<http://www.manual-lib.com>

<http://www.404manual.com>

<http://www.luxmanual.com>

<http://aubethermostatmanual.com>

Golf course search by state

<http://golfingnear.com>

Email search by domain

<http://emailbydomain.com>

Auto manuals search

<http://auto.somanuals.com>

TV manuals search

<http://tv.somanuals.com>