

GE Monogram®

Owner's Manual

ZDI15 and ZDIS15
Automatic Ice Maker

Introduction

Your new Monogram icemaker makes an eloquent statement of style, convenience and kitchen planning flexibility. Whether you chose it for its purity of design or the assiduous attention to detail, you'll find that your Monogram icemaker's superior blend of form and function will delight you for years to come.

The information on the following pages will help you operate and maintain your icemaker properly.

If you have any other questions—in the USA, please call the GE Answer Center® 800.626.2000. In Canada, please call 1.888.880.3030.

Contents

Care and Cleaning	13–16	Problem Solver	20
Consumer Services	23	Product Registration	2, 22
Controls and Features	10–11	Repair Service	3
Important Phone Numbers	23	Reversing the Door Swing	18–19
Model and Serial Numbers	2	Safety Instructions	4–9
Operating Instructions	12	Warranty	Back Cover
Preparation	17		

Before using your icemaker

Read this manual carefully. It is intended to help you operate and maintain your new icemaker properly.

Keep it handy for answers to your questions.

If you don't understand something or need more help, call in the USA:

GE Answer Center®
800.626.2000
24 hours a day, 7 days a week
In Canada, call 1.888.880.3030

Write down the model & serial numbers

You'll find them on a label on the left wall of the ice storage bin.

These numbers are also on the Consumer Product Ownership Registration Card packed separately with your icemaker.

Before sending in this card, please write these numbers here:

Model Number

Serial Number

Use these numbers in any correspondence or service calls concerning your icemaker.

*If you
received a
damaged
icemaker*

Immediately contact the dealer (or builder)
that sold you the icemaker.

*If you
need
service*

To obtain service, see the Consumer Services
page in the back of this manual.

We're proud of our service and want you to be
pleased. If for some reason you are not happy
with the service you receive, follow these steps.

For customers in the USA:

FIRST, contact the people who serviced your
appliance. Explain why you are not pleased.
In most cases, this will solve the problem.

NEXT, if you are still not pleased, write all the
details—including your phone number—to:

Manager, Customer Relations
GE Appliances
Appliance Park
Louisville, KY 40225

For customers in Canada:

FIRST, contact the people who serviced your
appliance. Explain why you are not pleased.
In most cases, this will solve the problem.

NEXT, if you are still not pleased, write all the
details—including your phone number—to:

Manager, Customer Relations
Camco Inc.
1 Factory Lane, Suite 310
Moncton, N.B. E1C 9M3

IMPORTANT SAFETY INSTRUCTIONS

READ AND SAVE THESE INSTRUCTIONS

Before it is used, the icemaker must be properly installed and located as described in this manual.

⚠ WARNING—To reduce the risk of fire, electrical shock or injury when using your icemaker, follow basic precautions including the following:

- Never allow children to operate, play with, or crawl inside the icemaker.
 - Never clean icemaker parts with flammable fluids. The fumes can create a fire hazard or explosion.
 - Do not store or use gasoline or other flammable vapors and liquids in the vicinity of this or any other appliance. The fumes can create a fire hazard or explosion.
 - Be sure your icemaker is properly installed and grounded by a qualified technician in accordance with the Installation Instructions.
 - Do not attempt to repair or replace any part of your icemaker unless it is specifically recommended in this manual. All other servicing should be referred to a qualified technician.
- Unplug the icemaker or disconnect power before cleaning, servicing or changing the light bulb. Failure to do so can result in death or electrical shock.
 - It is your responsibility to be sure your icemaker:
 - has been installed where it is protected from the elements.
 - is located so that the front is not blocked to restrict incoming or discharge air flow.
 - is connected only to the proper kind of outlet, with the correct electric supply and grounding. A 115 volt, 60 Hz., 15 amp fused electrical supply is required.

NOTE: Time delay fuse or circuit breaker is recommended.

- is not used by anyone unable to operate it properly.
- is used only to do what icemakers are designed to do.
- is properly maintained.

IMPORTANTES INSTRUCTIONS DE SÉCURITÉ

LIRE ET CONSERVER CES INSTRUCTIONS

Avant son utilisation, la machine à glaçons doit être bien installée et située selon la description dans ce manuel.



AVERTISSEMENT : Pour réduire les risques d'incendie, de choc électrique ou de blessure lors de l'utilisation de la machine à glaçons, suivre les précautions fondamentales, y compris les suivantes :

- Ne jamais laisser les enfants utiliser, employer comme jouet ou pénétrer dans la machine à glaçons.
- Ne jamais nettoyer les pièces de la machine à glaçons avec des fluides inflammables. Les émanations peuvent créer un risque d'incendie ou d'explosion.
- Ne pas entreposer ni utiliser de l'essence ou d'autres vapeurs et liquides inflammables dans le voisinage de cet appareil ménager ou de tout autre appareil. Les émanations peuvent créer un risque d'incendie ou d'explosion.
- S'assurer que la machine à glaçons est bien installée et reliée à la terre par un technicien qualifié, et conformément aux instructions d'installation.
- Ne pas essayer de réparer ou de remplacer une pièce de votre machine à glaçons à moins de recommandations spécifiques dans ce manuel. Tout autre besoin de service doit être soumis à un technicien qualifié.
- Débrancher la machine à glaçons ou déconnecter le courant électrique avant de la nettoyer, de l'entretenir ou de changer l'ampoule d'éclairage. L'omission d'observer ces précautions peut causer un décès ou un choc électrique.
- Vous avez la responsabilité de vous assurer que la machine à glaçons :
 - a été installée où elle est protégée contre les intempéries .
 - est située de sorte que le devant n'est pas obstruée pour restreindre l'arrivée ou la sortie du courant d'air.
 - est connectée seulement au type approprié de prise de courant avec une alimentation électrique correcte et une liaison à la terre. Une alimentation électrique de 115 V, 60 Hz, et fusible de 15 A est requise.

REMARQUE : Les fusibles temporisés ou disjoncteurs de circuit sont recommandés.

- n'est pas utilisée par quiconque ne peut faire fonctionner l'appareil d'une manière appropriée.
- est utilisée seulement pour accomplir ce que les machines à glaçons sont destinées à fournir.
- est soumise à un entretien approprié.

HOW TO CONNECT ELECTRICITY

Do not, under any circumstances, cut or remove the third (ground) prong from the power cord. For personal safety, this appliance must be properly grounded.

The power cord of this appliance is equipped with a 3-prong (grounding) plug which mates with a standard 3-prong (grounding) wall outlet to minimize the possibility of electric shock hazard from this appliance.

Have the wall outlet and circuit checked by a qualified electrician to make sure the outlet is properly grounded.

Where a standard 2-prong wall outlet is encountered, it is your personal responsibility and obligation to have it replaced with a properly grounded 3-prong wall outlet.

The icemaker should always be plugged into its own individual electrical outlet which has a voltage rating that matches the rating plate. This provides the best performance and also prevents overloading house wiring circuits which could cause a fire hazard from overheated wires.

Never unplug your icemaker by pulling on the power cord. Always grip plug firmly and pull straight out from the outlet.

Repair or replace immediately all power cords that have become frayed or otherwise damaged. Do not use a cord that shows cracks or abrasion damage along its length or at either end.

When moving the icemaker, be careful not to roll over or damage the power cord.

RACCORDEMENT ÉLECTRIQUE

Ne coupez ni retirez en aucun cas la troisième broche (mise à la terre) de la fiche du cordon d'alimentation. Pour votre sécurité, cet appareil doit être correctement mis à la terre.

Le cordon d'alimentation de cet appareil est muni d'une fiche à 3 broches (mise à la terre) qui se branche dans une prise mural ordinaire à 3 alvéoles (mise à la terre) pour réduire au minimum les risques du chocs électriques.

Faites examiner la prise de courant et le circuit par un électricien qualifié pour vous assurer que la prise est correctement mise à la terre.

Si la prise murale est du type standard à 2 alvéoles, il vous incombe de la faire remplacer par une prise à 3 alvéoles correctement mise à la terre.

La machine à glaçons doit toujours être branché dans sa propre prise de courant, dont la tension nominale est identique à celle indiquée sur la plaque signalétique.

Cette précaution est recommandée pour garantir un rendement optimum et éviter une surcharge des circuits électriques de la résidence, ce qui pourrait créer un risque d'incendie par surschauffe des fils.

Ne débranchez jamais la machine à glaçons en tirant le cordon d'alimentation. Saisissez fermement la fiche du cordon et tirez droit pour la retirer de la prise.

Réparez ou remplacez immédiatement tout cordon effiloché ou endommagé. N'utilisez pas un cordon fendillé ou présentant des signes d'usure.

Lorsque vous déplacez votre machine à glaçons du mur, faites attention de ne pas la faire rouler sur le cordon d'alimentation afin de ne pas l'endommager.

▲ DANGER: RISK OF CHILD ENTRAPMENT

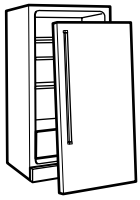

Child entrapment and suffocation are not problems of the past. Junked or abandoned refrigeration products are still dangerous... even if they will sit for "just a few days." If you are getting rid of your old appliance, please follow these instructions to help prevent accidents.

Before You Throw Away Your Old Refrigeration Product:

- Take off the doors.
- Leave the shelves in place so that children may not easily climb inside.

▲ DANGER! RISQUES POUR LES ENFANTS

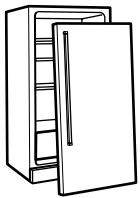

Les enfants pris au piège ou morts d'asphyxie sont toujours d'actualité. Les appareils de réfrigération abandonnés sont toujours aussi dangereux, même si on n'attend que "quelque jours" pour s'en débarrasser. Si vous ne gardez pas votre ancien appareil, veuillez suivre les directives ci-dessous afin de prévenir les accidents.

Avant de vous débarrasser de votre vieux appareil de réfrigération:

- Démontez les portes.
- Laissez les clayettes en place afin d'empêcher les enfants de grimper à l'intérieur.

CFC DISPOSAL

Old refrigeration products have cooling systems that used CFCs (chlorofluorocarbons). CFCs are believed to harm stratospheric ozone.

If you are throwing away an old refrigeration product, make sure the CFC refrigerant is removed for proper disposal by a qualified servicer. If you intentionally release this CFC refrigerant you can be subject to fines and imprisonment under provisions of environmental legislation.

SE DÉBARRASSER DU CFC

Les vieux appareils de réfrigération ont un système de refroidissement qui a utilisé les CFC (chlorofluorocarbones). Les CFC sont jugés nocifs pour l'ozone stratosphérique.

Si vous débarrassez de votre vieil appareil de réfrigération, assurez-vous que le frigorigène avec CFC soit enlevé correctement par un technicien qualifié. Si vous libérez intentionnellement ce frigorigène avec CFC vous pouvez être soumis aux contraventions et à l'emprisonnement après les stipulations des lois sur l'environnement.

USE OF EXTENSION CORDS

Because of potential safety hazards under certain conditions, we strongly recommend against the use of an extension cord.

However, if you must use an extension cord, it is absolutely necessary that it be a UL-listed (in the United States) or a CSA-listed (in Canada),

3-wire grounding type appliance extension cord having a grounding type plug and outlet and that the electrical rating of the cord be 15 amperes (minimum) and 120 volts.

CORDONS PROLONGATEURS

Nous vous recommandons fortement de ne pas utiliser de cordons prolongateurs à cause des risques potentiels qu'ils présentent dans certaines conditions.

Toutefois si vous décidez d'utiliser tout de même un cordon prolongateur, il est

absolument nécessaire qu'il s'agisse d'un cordon à 3 fils avec mise à la terre pour appareils électroménagers homologué UL (aux États-Unis) ou homologué CSA (au Canada), pourvu d'une fiche et d'une prise mises à la terre de 15 ampères (minimum) et de 120 volts.

USE OF ADAPTER PLUGS *(Adapter plugs not permitted in Canada)*

Because of potential safety hazards under certain conditions, we strongly recommend against the use of an adapter plug.

However, if you must use an adapter, where local codes permit, a **temporary connection** may be made to a properly grounded 2-prong wall outlet by use of a UL-listed adapter available at most local hardware stores.

The larger slot in the adapter must be aligned with the larger slot in the wall outlet to provide proper polarity in the connection of the power cord.

When disconnecting the power cord from the adapter, always hold the adapter in place with one hand while pulling the power cord plug with the other hand. If this is not done, the

adapter ground terminal is very likely to break with repeated use.

If the adapter ground terminal breaks, **DO NOT USE** the refrigerator until a proper ground has been established.

Attaching the adapter ground terminal to a wall outlet cover screw does not ground the appliance unless the cover screw is metal, and not insulated, and the wall outlet is grounded through the house wiring. You should have the circuit checked by a qualified electrician to make sure the outlet is properly grounded.

SAVE THESE INSTRUCTIONS

FICHE D'ADAPTATION *(Fiches d'adaptation non permises au Canada)*

Nous vous recommandons fortement de ne pas utiliser une fiche d'adaptation à cause des risques potentiels qu'elle présente dans certaines circonstances.

Toutefois, si vous décidez d'utiliser tout de même une fiche d'adaptation, vous pouvez effectuer un **raccordement temporaire**, si les codes locaux le permettent, dans une prise de courant à 2 alvéoles adéquatement mise à la terre en utilisant une fiche d'adaptation homologuée UL, en vente dans la plupart des quincailleries.

La fente la plus longue de la fiche doit être alignée avec la fente la plus longue de la prise murale afin d'assurer la polarité appropriée pour le branchement du cordon d'alimentation.

Lorsque vous débranchez le cordon d'alimentation de la fiche d'adaptation, saisissez toujours la fiche d'une main pendant que vous tirez sur la fiche du cordon

d'alimentation de l'autre. Sinon, la borne de mise à la terre de la fiche d'adaptation risque de casser avec le temps.

Si la borne de mise à la terre de la fiche casse, **N'UTILISEZ PAS** l'appareil tant qu'une mise à la terre adéquate n'aura pas été rétablie.

Le fait de fixer la borne de mise à la terre de la fiche d'adaptation à la plaque de la prise de courant n'assure pas automatiquement la mise à la terre de l'appareil. Il faut que la vis soit en métal, non isolée, et que la prise de courant soit mise à la terre par l'entremise du câblage de résidence. Faites vérifier le circuit par un électricien qualifié pour vous assurer que la prise est adéquatement mise à la terre.

CONSERVEZ CES DIRECTIVES

Remove packaging

IMPORTANT: Do not remove any permanent instruction labels inside your icemaker or the Tech Sheet that is fastened behind the lower access panel.

- Remove tape and any labels from your icemaker before using (except the model and serial number label).

To remove any remaining tape or glue, rub the area briskly with your thumb. Tape or glue residue can also be easily removed by rubbing a small amount of liquid dish soap over the adhesive with your fingers. Wipe with warm water and dry.

- Do not use sharp instruments, rubbing alcohol, flammable fluids or abrasive cleaners to remove tape or glue. These products can damage the surface of your icemaker. For more information, see the *Important Safety Instructions* section.

Clean before using

After you remove all of the packaging materials, clean the inside of your icemaker before using it.

See the cleaning instructions in the Care and Cleaning section.

Set controls

1. To start the normal ice making cycle, select ON.
2. To stop icemaker operation, select OFF.

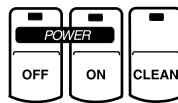

NOTE: The CLEAN setting is used whenever solutions are circulated through the icemaker for cleaning. Only the water pump operates at this setting. See the *Care and Cleaning* section.

*Features of your
icemaker*

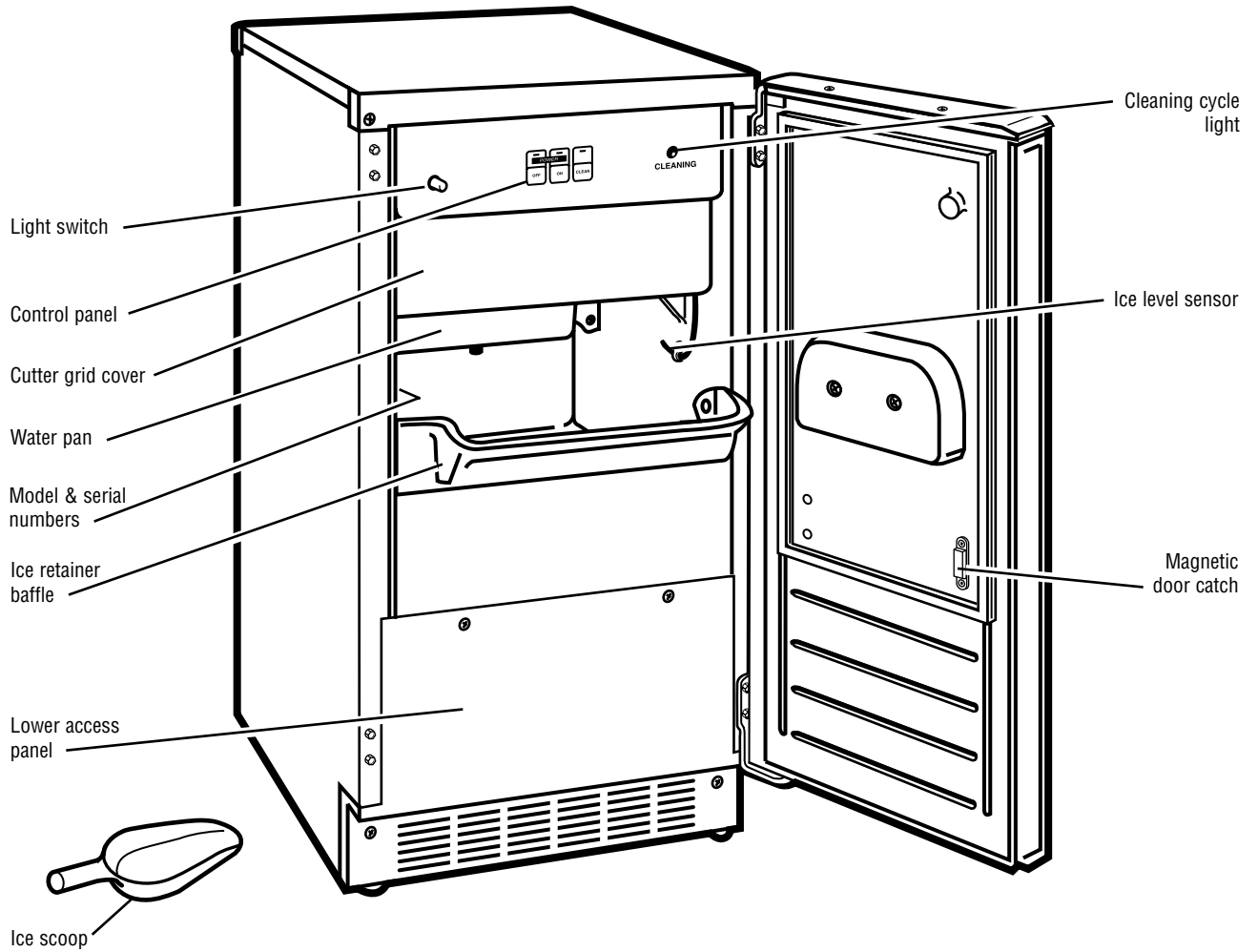

How your icemaker works

When you first start your icemaker, the water pan will fill and the system will rinse itself before starting to make ice. The rinsing process takes about five minutes.

Under normal operating conditions, the icemaker will cycle at preset temperatures. The ice level sensor located in the ice storage bin will monitor the ice levels.

IMPORTANT

- If the water supply to the icemaker is turned off, be sure to set the icemaker control to OFF.
- The icemaker is designed to make clear ice from the majority of water sources on a daily basis. If your results are unsatisfactory, your water may need to be filtered or treated.

Making Ice

1. Water is constantly circulated over a freezing plate. As the water freezes into ice, the minerals in the water are rejected. This produces a clear sheet of ice with a low mineral content.

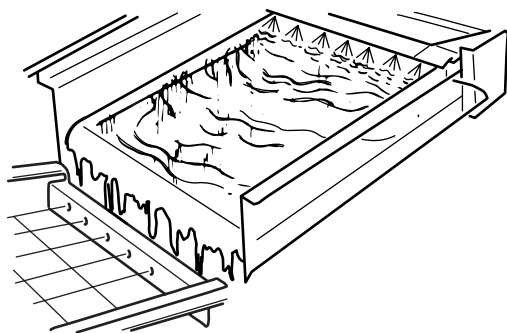

2. When the desired thickness is reached, the ice sheet is released and slides onto a cutter grid. The grid divides the sheet into individual cubes.

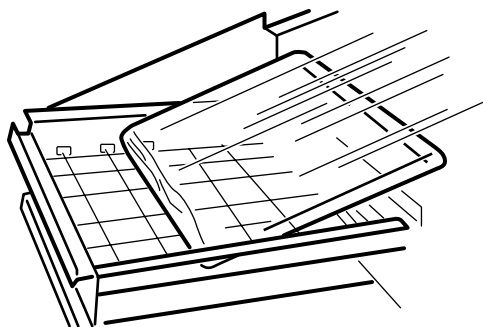

3. The water containing the rejected minerals is drained after each freezing cycle.
4. Fresh water enters the machine for the next ice making cycle.
5. Cubes fall into the storage bin. When the bin is full, the icemaker shuts off automatically and restarts when more ice is needed. The ice bin is not refrigerated and some melting will occur. The amount of melting varies with room temperature.

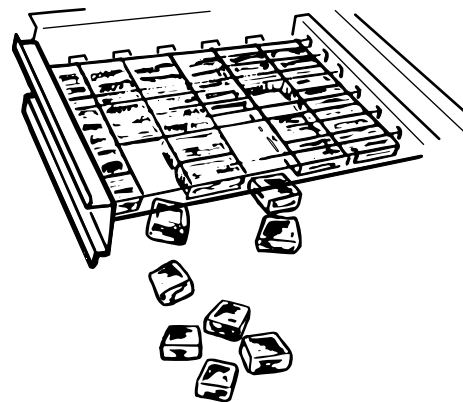

NOTE: As the room and water temperatures vary, so will the amount of ice produced and stored. This means that higher operating temperatures result in reduced ice production.

Unplug the icemaker before cleaning.

Caring for your icemaker

Periodically inspect and clean the icemaker to keep it operating at peak efficiency.

Both the ice making system and the air cooled condenser need to be cleaned regularly. The minerals rejected from the circulating water during the freezing cycle will eventually form a hard scaly deposit in the water system which prevents a rapid release of the ice from the freezing plate.

Clean the ice and water system periodically to remove mineral scale buildup. Frequency of cleaning depends on water hardness. With hard water (15 to 20 grains/gal. [4 to 5 grains/liter]), cleaning may be required as frequently as every 6 months.

For best performance, brush or vacuum lint and dirt from the condenser once a year. Unscrew the grille on the bottom front of the cabinet to access the condenser.

Exterior surfaces

Wash the exterior enamel surfaces and gaskets with warm water and mild soap or detergent. Wipe and dry. Regular use of a good household appliance cleaner and wax will help protect the finish.

Do not use abrasive cleaners on enamel surfaces as they may scratch the finish.

Models with a stainless steel exterior can be cleaned with a commercially available stainless steel cleaner using a clean, soft cloth. Do not use appliance wax or polish on the stainless steel.

Icemaker system

1. Push the selector switch to OFF.
2. Wait 5 to 10 minutes for the ice to fall into the storage bin. Remove all ice from the storage bin.
3. Unscrew the drain cap from the bottom of the water pan located inside the storage bin as shown. Allow the water to drain completely.

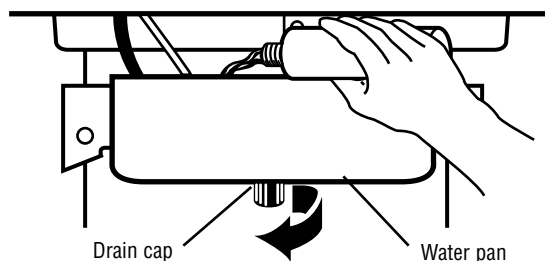

4. Replace the drain cap.
5. Use one 16 oz. bottle of Nickel Safe Ice Machine Cleaner by Nu Calgon. Read and follow all safety precautions on the bottle. Pour one bottle of solution into the water reservoir. Fill the bottle twice with tap water and pour it into the water reservoir.

Nickel Safe Ice Machine Cleaner by Nu Calgon is available at appliance repair shops, or through

GE Parts and Accessories. Order part number WX08X42870. In the U.S.A., call 800.626.2002 or visit GEAppliances.com. In Canada, call 1.888.880.3030.

6. Push the selector switch to CLEAN. The light will turn on, indicating that the cleaning cycle is in process.

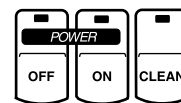

7. When the indicator light turns off (approximately 45 minutes), the cleaning cycle is complete. During the cleaning cycle, the system will both clean and rinse itself.
8. After the cleaning cycle is complete, remove the drain cap from the water pan to see if any cleaning solution is left in the water pan. If cleaning solution drains from the water pan, you should run the clean cycle again.

NOTE: Severe scale buildup may require repeated cleaning with a fresh quantity of cleaning solution.

9. Push the selector switch to ON to resume ice production.

Condenser

A dirty or clogged condenser:

- Prevents proper airflow.
- Reduces ice making capacity.
- Causes higher than recommended operating temperatures which may lead to component failure.

1. Unplug the icemaker or disconnect power.
2. Remove the 2 screws in the lower access panel and the 2 screws from the base grille area of the front panel support. Pull forward to remove the lower access panel.
3. Pull the bottom forward and then pull down to remove the lower access panel.

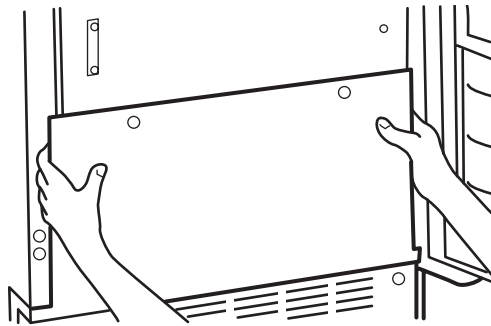

4. Remove dirt and lint from the condenser fins and the unit compartment with a brush attachment attached to a vacuum cleaner.

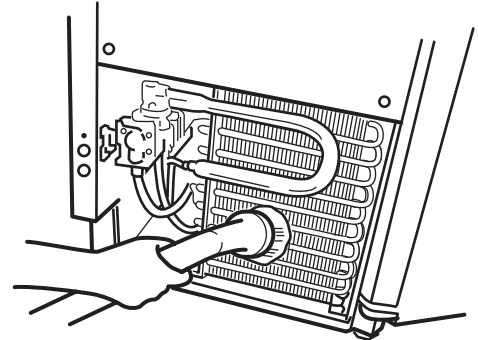

5. Replace the lower access panel using the 4 screws.
6. Plug in the icemaker or reconnect power.

Interior

1. Unplug the icemaker or disconnect power.
2. Open the storage bin door and remove any ice that is in the bin.
3. Remove the drain cap from the water pan and drain thoroughly. Replace the drain cap.
4. Remove the three screws that hold the cutter grid cover in place.
5. Unplug the wiring harness from the left side of the cutter grid.

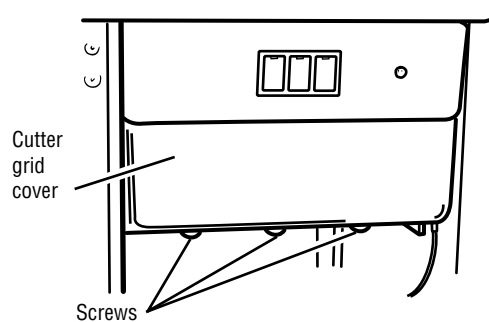

6. Unplug the ice level sensor from the right side of the cutter grid. Pull the ice level sensor down and forward away from the cutter grid.
7. Remove the right-hand screw and loosen the left-hand screw. Lift the cutter grid up and out over the left-hand screw.

NOTE: Make sure the plastic spacer from the right-hand side of the cutter grid bracket stays with the cutter grid.

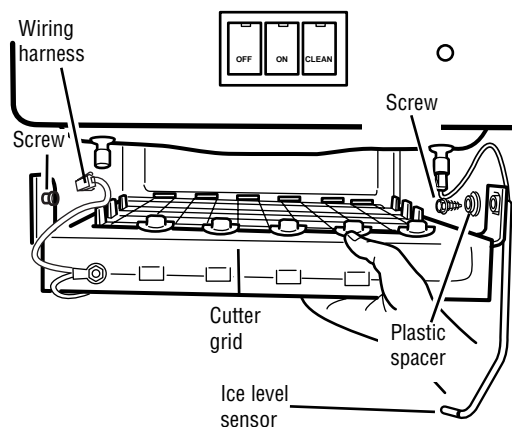

8. Remove the two screws that hold the water pan in place. Push down with one hand on

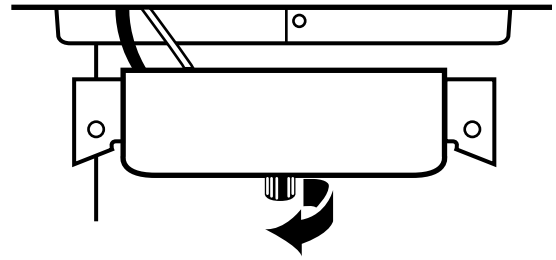

the front of the pan while pulling forward on the bottom back side.

9. The cutter grid, exterior of hoses, water pan, storage bin, door gasket and ice scoop should be cleaned with mild soap or detergent and warm water. Rinse in clean water. Then clean the same parts with a solution of 1 tablespoon (15 mL) of household bleach in 1 gallon (3.8 L) warm water. Rinse again thoroughly in clean water.

NOTE: Do not remove hoses. Do not wash plastic parts in dishwasher. They cannot withstand high temperatures.

10. Wash only the outside of the plastic hoses with mild soap or detergent and warm water. Rinse with clean water.
11. Replace water pan by pushing back on the bottom with one hand while pushing up and back on the top. Secure the water pan by replacing both screws.
12. Check the following:
 - Drain cap from the water pan is in place.
 - Hose from the water pan is inserted into the storage bin drain opening.
13. Slide the cutter grid back into place and secure it by replacing the right-hand screw and tightening the left-hand screw. Reconnect the electrical and ice level sensor harnesses.
14. Replace the cutter grid cover with three screws.
15. Plug in the icemaker or reconnect power.
16. Reset the controls. See the *Set controls* section.

Light bulb replacement

The icemaker has a light bulb in the top of the storage bin. To replace it, open the bin door and follow these instructions:

1. Unplug the icemaker or disconnect power.
2. Remove the 3 screws that hold the cutter grid cover in place. Reach behind the control panel and pull the light bulb down.
3. Replace with a 12-volt wedge base-type bulb (automotive #917). Locate the light bulb receptacle at the top behind the control panel. Align the flat edge of the light bulb with the receptacle and snap the bulb into place.
4. Replace the cutter grid cover with the 3 screws.
5. Plug in the icemaker or reconnect power.

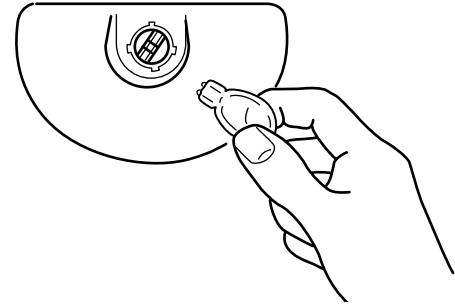

Vacation and moving

To shut down the icemaker:

1. Unplug the icemaker or disconnect power.
2. Remove all ice from the storage bin.
3. Shut off the water supply.
4. Remove the 2 screws in the lower access panel and the 2 screws from the base grille area of the front panel support. Pull forward to remove the lower access panel.

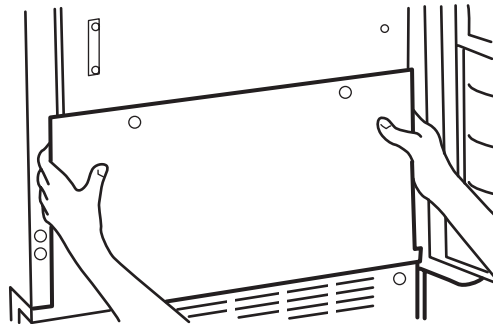

5. Disconnect the inlet and outlet lines to water valve. Allow these lines to drain and then reconnect to the valve.
6. Replace the lower access panel and screws. Drain water from water pan by removing the drain cap. Also, remove water from drain line.
7. Before using again, clean the icemaker and storage bin.
8. Plug in the icemaker or reconnect power.

NOTE: All components of the icemaker are permanently lubricated at the factory. They should not require any additional oiling throughout the normal life of the machine.

Front leveling legs

Your icemaker has 2 adjustable leveling legs to help you steady the product and make sure it is level.

1. Place a carpenter's level on top of the icemaker to make sure it is level from front to back and side to side.
2. Lift the top front of the icemaker to locate the leveling screws that are on the bottom front.
3. Using an adjustable wrench, change the height of the legs as follows:
 - Turn the leveling leg to the right to lower that side of the icemaker.
 - Turn the leveling leg to the left to raise that side of the icemaker.

NOTE: The icemaker should not wobble. Use shims to add stability when needed.

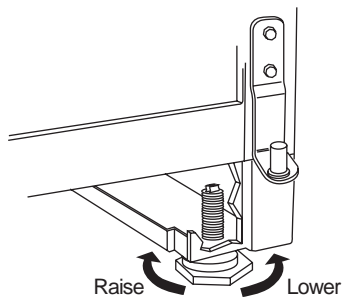

4. Use a carpenter's level to make sure the icemaker is even from front to back and side to side.

Reversing the Door Swing

Icemaker

To reverse
the door

TOOLS NEEDED: 5/16" wrench, 1/4" wrench,
flat putty knife, Phillips screwdriver

Parts Supplied:

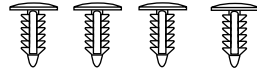

Four plug buttons

Parts Identification: (For Reference Only)



Hinge Pin



Handle Screw



5/16" Hex Head
Hinge Screw

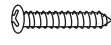

Endcap Screw

IMPORTANT: Before you begin, unplug the
icemaker or disconnect power.

To remove door from hinges:

1. Remove the handle screws and lift off the
handle (on some models). Keep the parts
together and set them aside.
2. Remove the hinge pin from the top hinge.
3. Lift the door off of the bottom hinge.
Place the hinge pin back into the top hinge.
4. Reverse the door endcaps as follows:
 - Remove the screws and endcaps from the
door, top and bottom.
 - Place the top endcap on the bottom of the
opposite side of the door with the long flat
side facing the door front.
 - Place the bottom endcap on the top of the
opposite side of the door with the long flat
side facing the door front.
5. Set the door aside.

To reverse the hinges:

1. Using a flat putty knife, remove the plug
buttons from the screw holes opposite of the
door hinges, top and bottom. Set aside.
2. Remove the two screws holding the top
hinge. Turn the hinge upside down so that
the hinge pin points up. Place the hinge on
the opposite side at the bottom of the door.
3. Remove the plastic hinge sleeve from the
"old" bottom hinge and replace it on the
new bottom hinge pin.
4. Remove the bottom hinge. Turn the hinge
upside down so that the hinge pin points
down. Place the hinge on the opposite side
at the top of the door.
5. Push the plug buttons into the original
screw holes.
6. Remove the top hinge pin.

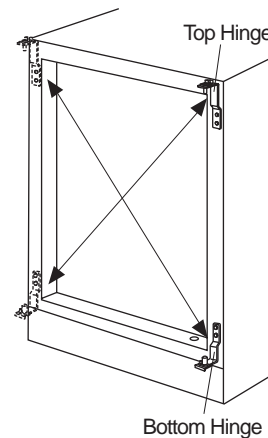

Top Hinge

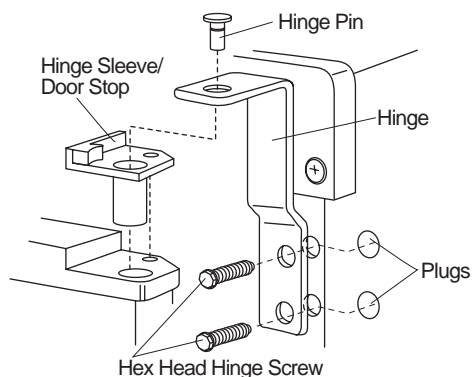

Bottom Hinge

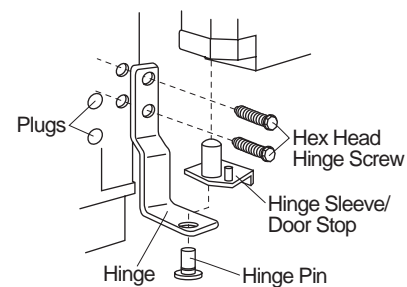

To reverse the door

To replace door on hinges:

1. Place plastic hinge sleeve on bottom hinge and position the door on the pin.
2. Place plastic hinge sleeve in the top hinge hole on the door. Align the door on the bottom hinge and replace the top hinge pin.
3. Replace the handle and handle screws.

To reverse the door catch:

1. Remove the plug buttons from the opposite side of the door.
2. Remove the screws from the magnetic door catch and replace it on the opposite side of the door.
3. Push the plug buttons into place on the opposite side of the door.

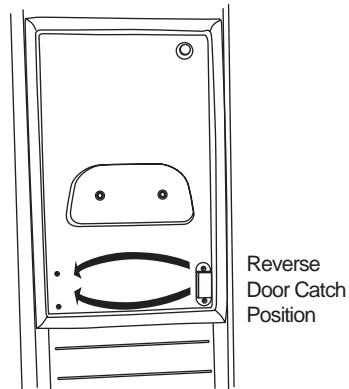

The Problem Solver

Icemaker

Questions?

Use this
problem solver!

PROBLEM	POSSIBLE CAUSE
ICEMAKER DOES NOT OPERATE	<ul style="list-style-type: none"> • Power cord is not plugged into a live outlet. • The control is set at OFF. • The fuse is blown/circuit breaker is tripped. Replace fuse or reset the breaker. • Room temperature is colder than normal. Room temperature must be above 55°F (13°C). Otherwise, bin thermostat may sense cold room temperature and shut off even though the bin is not full of ice. Also, unit may not restart once it does shut off.
ICE CUBES HAVE ODOR/TASTE	<ul style="list-style-type: none"> • High mineral content in the water supply. Water may need to be filtered or treated. • Food items stored in ice bin. Do not store any foods in the ice bin. • Packaging materials were not removed. Make sure that all packaging materials were removed at the time of installation. • Ice storage bin needs cleaning. • Scale has built up in the icemaker. If there is white scale buildup in the icemaker's water or freezing system, you should clean the icemaker. See <i>Care and Cleaning—Icemaker System</i>.
ICEMAKER IS ON, BUT DOESN'T PRODUCE ICE	<ul style="list-style-type: none"> • The control is set at OFF. • Water supply is not connected. • Condenser is dirty. Dirt or lint may be blocking the airflow through the condenser. See <i>Care and Cleaning—Condenser</i>. • Scale has built up in the icemaker. If there is white scale buildup in the icemaker's water or freezing system, you should clean the icemaker. See <i>Care and Cleaning—Icemaker System</i>.
ICEMAKER IS ON, BUT PRODUCES LITTLE OR NO ICE	<ul style="list-style-type: none"> • Room temperature is too hot. Room temperatures of more than 90°F (32°C) will normally reduce ice production. • Condenser is dirty. Dirt or lint may be blocking the airflow through the condenser. See <i>Care and Cleaning—Condenser</i>. • Scale has built up in the icemaker. If there is white scale buildup in the icemaker's water or freezing system, you should clean the icemaker. See <i>Care and Cleaning—Icemaker System</i>. • Water is leaking from the water pan because the drain cap is not secure. Make sure the drain cap is securely tightened.
GRID IS NOT CUTTING ICE SHEETS	<ul style="list-style-type: none"> • Cutter grid is not securely in place. Unplug the icemaker or disconnect power. Remove the cutter grid cover and check the cutter grid harness plug to make sure the connection is secure. For instructions on removing and replacing the cutter grid and the location of the harness plug, see <i>Care and Cleaning—Interior</i>.
ICEMAKER PUMPS CONTINUOUSLY, BUT PRODUCES NO ICE	<ul style="list-style-type: none"> • The ice sheet is trapped on the cutter grid. Unplug the icemaker or disconnect power. Remove the cutter grid cover and move the ice sheet to the cutter grid. Make sure the cutter grid is lined up with the freezing plate. See <i>Operating Instructions—How your icemaker works</i>. If it is not lined up with the freezing plate, adjust the cutter grid. For instructions on removing and replacing the cutter grid, see <i>Care and Cleaning—Interior</i>. Reinstall the cutter grid cover and reconnect power. Turn on the icemaker. The icemaker will reset itself and start a new cycle after flushing water through the system.

Consumer Product Ownership Registration Important Mail Today

GE Appliances



Place
1st Class
Letter
Stamp
Here

General Electric Company
Warranty Registration Department
P.O. Box 32150
Louisville, KY 40232-2150

Consumer Product Ownership Registration

Dear Customer:

Thank you for purchasing our product and thank you for placing your confidence in us. We are proud to have you as a customer!

Follow these three steps to protect your new appliance investment:

1 Complete and mail your Consumer Product Ownership Registration today. Have the peace of mind of knowing we can contact you in the unlikely event of a safety modification.

2 After completing this registration, write your model and serial numbers in this manual. You will need this information should you require service. The service number in the USA: 800.444.1845. In Canada, call: 1.888.880.3030.

3 Read your "Owner's Manual" carefully. It will help you operate your new appliance properly.

Important: To ensure that your product is registered, mail the separate product registration card. If the separate product registration card is missing, fold and mail the form below. No envelope is needed.

FOLD HERE

Consumer Product Ownership Registration



Product
Ice maker

Model

Serial

Mr. Ms. Mrs. Miss

First Name _____ Last Name _____

Street Address _____

Apt. # _____

City _____ State _____ Zip Code _____

Date Placed In Use _____ Day _____ Year _____ Phone Number _____ - _____ - _____



monogram.com



TAPE CLOSED

With the purchase of your new Monogram appliance, receive the assurance that if you ever need information or assistance from GE, we'll be there. All you have to do is call—toll-free!

GE Answer Center®

***In the USA:
800.626.2000***

Whatever your question about any Monogram major appliance, GE Answer Center® information service is available to help. Your call—and your question—will be answered promptly and courteously. And you can call any time. GE Answer Center® service is open 24 hours a day, 7 days a week.

OR

Visit our Website at: monogram.com

In Canada, call 1.888.880.3030.

In-Home Repair Service

***In the USA:
800.444.1845***

***In Canada:
1.888.880.3030***

A GE consumer service professional will provide expert repair service, scheduled at a time that's convenient for you. Many GE Consumer Service company-operated locations offer you service today or tomorrow, or at your convenience (7:00 a.m. to 7:00 p.m. weekdays, 9:00 a.m. to 2:00 p.m. Saturdays). Our factory-trained technicians know your appliance inside and out—so most repairs can be handled in just one visit.

For Customers With Special Needs...

***In the USA:
800.626.2000***

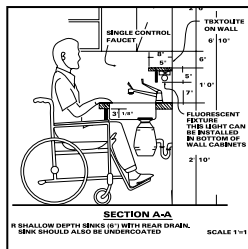

GE offers Braille controls for a variety of GE appliances, and a brochure to assist in planning a barrier-free kitchen for persons with limited mobility.

Consumers with impaired hearing or speech who have access to a TDD or a conventional teletypewriter may call 800.TDD.GEAC (800.833.4322) to request information or service.

Service Contracts

***In the USA:
800.626.2224***

***In Canada:
1.888.880.3030***

You can have the secure feeling that GE Consumer Service will still be there after your warranty expires. Purchase a GE contract while your warranty is still in effect and you'll receive a substantial discount. With a multiple-year contract, you're assured of future service at today's prices.

Parts and Accessories

***In the USA:
800.626.2002***

***In Canada:
1.888.880.3030***

Individuals qualified to service their own appliances can have parts or accessories sent directly to their home. The GE parts system provides access to over 47,000 parts...and all GE Genuine Renewal Parts are fully warranted. VISA, MasterCard and Discover cards are accepted.

User maintenance instructions contained in this manual cover procedures intended to be performed by any user. Other servicing generally should be referred to qualified service personnel. Caution must be exercised, since improper servicing may cause unsafe operation.

YOUR MONOGRAM ICEMAKER WARRANTY

Staple sales slip or cancelled check here. Proof of original purchase date is needed to obtain service under warranty.

WHAT IS COVERED

From the Date of the Original Purchase

FULL ONE-YEAR WARRANTY

For one year from date of original purchase, we will provide, free of charge, parts and service labor in your home to repair or replace *any part of the icemaker* that fails because of a manufacturing defect.

FULL FIVE-YEAR WARRANTY

For five years from date of original purchase, we will provide, free of charge, parts and service labor in your home to repair or replace *any part of the sealed icemaking system* (the compressor, condenser, evaporator and all connecting tubing) that fails because of a manufacturing defect.

.....
This warranty is extended to the original purchaser and any succeeding owner for products purchased for ordinary home use in the 48 mainland states, Hawaii and Washington, D.C. or Canada. In Alaska, the warranty is the same except that it is LIMITED because you must pay to ship the product to the service shop or for the service technician's travel costs to your home.

All warranty service will be provided by our Factory Service Centers or by our authorized Customer Care® servicers during normal working hours.

Should your appliance need service, during warranty period or beyond, in the U.S.A., call 800.444.1845. In Canada: 888.880.3030.

WHAT IS NOT COVERED

- Service trips to your home to teach you how to use the product.
 - Replacement of house fuses or resetting of circuit breakers.
 - Damage to the product caused by accident, fire, floods or acts of God.
 - Failure of the product if it is used for other than its intended purpose or used commercially.
 - Improper installation.
- If you have an installation problem, contact your dealer or installer. You are responsible for providing adequate electrical, plumbing and other connecting facilities.
- Incidental or consequential damage caused by possible defects with this appliance.

Some states/provinces do not allow the exclusion or limitation of incidental or consequential damages, so the above limitation or exclusion may not apply to you. This warranty gives you specific legal rights, and you may also have other rights which vary from state to state/province to province. To know what your legal rights are in your state/province, consult your local or state/provincial consumer affairs office or your state's Attorney General.

Warrantor: General Electric Company. If further help is needed concerning this warranty, write: Manager—Customer Relations, GE Appliances, Louisville, KY 40225



Part No. 2217244
Pub No. 49-60027-1
12-01 JR

Printed in the United States

Free Manuals Download Website

<http://myh66.com>

<http://usermanuals.us>

<http://www.somanuals.com>

<http://www.4manuals.cc>

<http://www.manual-lib.com>

<http://www.404manual.com>

<http://www.luxmanual.com>

<http://aubethermostatmanual.com>

Golf course search by state

<http://golfingnear.com>

Email search by domain

<http://emailbydomain.com>

Auto manuals search

<http://auto.somanuals.com>

TV manuals search

<http://tv.somanuals.com>