

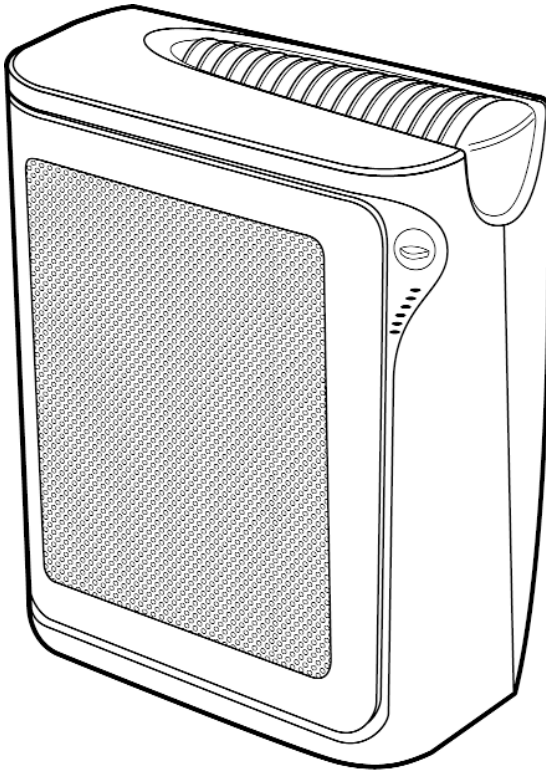

HEPA Air Purifier



GE SMARTAIRE™ HEPA FILTER # 106773 / # 106743
GE SMARTAIRE™ CARBON FILTER #106753

106633
106643
106653

For Consumer Assistance Please Call: 1- 877-207-0923

PLEASE READ AND SAVE THESE IMPORTANT SAFETY INSTRUCTIONS

When using electrical appliances, basic safety precautions should always be followed to reduce the risk of fire, electric shock, and injury to persons, including the following:

1. Read all instructions before using the appliance.
2. To avoid fire or shock hazard, plug the appliance directly into a 120V AC electrical outlet.
3. If the filter is covered by a bag when shipped: Remove plastic bag over filter before use.
4. Keep the cord out of heavy traffic areas. To avoid fire hazard, NEVER put the cord under rugs, near heat registers, radiator, stoves, or heaters.
5. Close supervision is necessary when any appliance is used by or near children or by disabled people.
6. NEVER place air purifier in an area where it is accessible to children.
7. **WARNING:** always unplug the air purifier before moving it, opening the grill, changing filters, cleaning or whenever the air purifier is not in use. Be sure to pull by the plug and not the cord.
8. Never block the air openings, grills/outlets or place on a soft surface such as a bed or sofa, as this could cause the unit to tip over, blocking the Air Intake Opening/Grill.
9. Never drop or insert any object into any openings.
10. To protect against electrical hazards, DO NOT immerse in water or other liquids. Do not use near water.
11. DO NOT operate any appliance with a damaged cord or plug, after the appliance malfunctions, or if it has been dropped or damaged in any manner. Return appliance to manufacturer for examination, electrical or mechanical adjustment or repair.
12. Use appliance only for intended household use as described in this manual. Any other use not recommended by the manufacturer may cause fire, electric shock, or injury to persons. The use of attachments not recommended may cause hazards.
13. DO NOT use outdoors.
14. DO NOT puncture filters
15. Air purifier should be unplugged when not in use.
16. NEVER use detergents, gasoline, glass cleaner, furniture polish, paint thinner, or other household solvents to clean any part of the air cleaner.
17. DO NOT attempt to repair or adjust an electrical or mechanical functions on this unit. Doing so will void your warranty. The inside of the unit contains no user serviceable parts. All servicing should be performed by qualified personnel only.
18. DO NOT plug the cord in with wet hands: electric shock could result.
19. **WARNING:** To reduce the risk of fire or electric shock, DO NOT use this air purifier with any solid state speed control device.
20. Keep away from heated surfaces and open flames.
21. DO NOT place anything on top of unit.

22. To avoid risk of fire, DO NOT place air purifier against or within 3 feet of any heat source.

PLEASE READ AND SAVE THESE IMPORTANT SAFETY INSTRUCTIONS

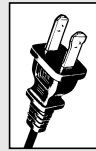

THIS PRODUCT IS EQUIPPED WITH A POLARIZED AC (Alternating Current) PLUG (a plug having one blade wider than the other). This plug will fit into the power outlet only one way. If the plug does not fit fully into the outlet, reverse the plug. If it still does not fit, contact qualified personnel to install the proper outlet. DO NOT DEFEAT THE SAFETY PURPOSE OF THIS POLARIZED PLUG IN ANY WAY.

Consumer Safety Information

Note: This is an electrical appliance and requires attention when in use.

Note: DO NOT block air intake grill or filtered air outlet.

Cord and Plug Installation Safety Instructions

The length of cord used on this appliance was selected to reduce the hazards of becoming tangled in, or tripping over a longer cord. If a longer cord is necessary an approved extension cord may be used. The electrical rating of the extension cord must be equal to or greater than the rating of the air purifier (5 Amps or 600 Watts). Care must be taken to arrange the extension cord so that it will not drape over the countertop or tabletop where it can be pulled on by children or accidentally tripped over.

FEATURES - OPERATION

How the HEPA Air Cleaner Works

Your GE Brand HEPA Air Purifier draws dirty air through the front air intake grill area. This air is then passed through a foam pre-filter, a carbon filter and HEPA filter, which helps retain the particles in the air such as dust, smoke, pollen, mold spores and pet dander. The resulting filtered air is directed back into the room from the top outlet grill.

NOTE: This air purifier filter removes 99.97% of airborne particles as small as 0.3 microns from air passing through it.

Dual Position

The air purifier can stand upright or lie on its side. It is designed to fit with its back flush against a wall.

When positioning the unit, please be sure the air inlet grill, filters and air outlet are not blocked to ensure maximum airflow.

PRE-OPERATING INSTRUCTIONS

1. After removing the unit from the box, take the plastic covering off the unit and discard it.
2. Place unit with air intake grill pointing up.
3. Open the door of the air purifier.
4. The Carbon filters are packed in a plastic bag loose inside the box. Please remove the plastic and discard.
5. The Carbon filters should be put on each of the HEPA filters. The plastic tabs on the HEPA filter will hold the carbon in place. (fig. 1.)
6. Close the air purifier door by pushing firmly against the right hand side of the door.

Figure 4

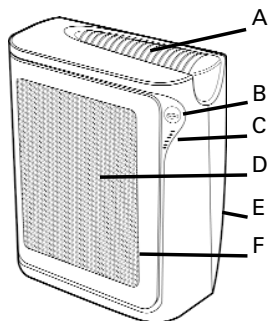

- A. Filtered Air Outlet
- B. Speed Control Knobs
- C. Filter Life Monitor
- D. Air Intake Grill
- E. Power Cord
- F. Door

OPERATING INSTRUCTIONS

1. Select a location where the air intake grill and filtered air outlet are not obstructed.
2. Plug into a 120V AC electrical outlet.
3. The air purifier is now ready for your use. Please set the unit to the desired speed setting; High ❖❖, Medium ❖, Low ♦♦ or Sleep ♦.

FILTER LIFE MONITOR

The filter life monitor uses a series of lights to give you an indication of the remaining filter life. With the new filters the top light will be illuminated green. As the filter life progresses the filter life indicator will move to yellow, and your HEPA filters should be checked for particulate accumulation. When the filter life indicator light is red, it is time to change the HEPA filters.

CLEANING AND MAINTENANCE INSTRUCTIONS

1. Turn the air purifier off and unplug it before cleaning.
2. The outside of the air purifier can be cleaned with a soft, clean dampened cloth.
3. The filtered air outlet on the top of the unit can be cleaned of dust with a small, soft brush.
4. If you wish to clean the inside of the air purifier, please only use a dry, soft cloth to wipe it down.

Figure 1

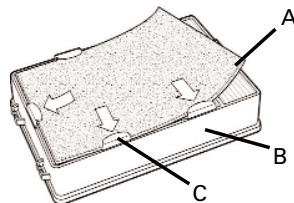

- A. Carbon Filter
- B. HEPA Filter
- C. Plastic tabs

REPLACING THE FILTER CLEANING INSTRUCTIONS - STORAGE

REPLACING THE FILTERS

1. On average, HEPA filters need to be replaced every 12 - 18 months. Carbon filters need to be replaced every 3 - 6 months. Filter life will vary depending on air quality and usage. Replace filters if punctured.
2. Turn off and unplug the air purifier before attempting to replace the filters.
3. Remove each of the filters from the unit by pulling gently towards you.
4. To replace the carbon filter, simply remove the old carbon filter and insert a new carbon in its place, using the plastic tabs as a guideline. (See Fig.1)
5. To replace the HEPA filter, discard the old HEPA filter. Put a new carbon filter on the HEPA filter. Insert the new HEPA filter into the unit, by sliding it onto the hang tabs. (See Fig. 2)
6. After replacing the HEPA filter, RESET the filter life monitor by inserting a small object (such as a pin or paper clip) into the hole marked RESET.

NOTE: Carbon and HEPA filters are not washable and should be replaced at the recommended intervals.

PRE-FILTER CLEANING/REPLACEMENT INSTRUCTIONS

1. Every 2-3 weeks, check the condition of the foam pre-filter.
2. Open the front door and remove the Pre-filter frame to examine the pre-filter (fig. 3).
3. If the Pre-filter has a noticeable amount of dust, lint, or particulate accumulation, wash it by hand in warm soapy water. The pre-filter must be washed at least every 30 days or more often as necessary. If the pre-filter is worn or damaged, replace it (go to step 5.). **DO NOT wash in an automatic washer, gently hand wash only.**
4. After washing, rinse and dry the pre-filter thoroughly before replacing it into the air purifier door. **DO NOT dry the pre-filter in an automatic dryer, hand dry only by dabbing gently with a dry cloth towel.**
5. Replace pre-filter in door and latch pre-filter frame (fig.3).

CAUTION: DO NOT OPERATE AIR PURIFIER WITHOUT A PRE-FILTER IN PLACE. DIRT AND LINT WILL CLOG IT AND REDUCE PERFORMANCE.

Figure 2

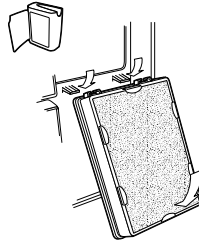

STORAGE INSTRUCTIONS

If your air purifier will not be used for an extended period of time, please follow the below instructions.

1. Turn unit off and unplug.
2. Clean Pre-filter and dry completely. See Pre-filter cleaning instructions.
3. Remove Carbon and HEPA filters and discard.
4. Wipe air purifier clean as in cleaning instructions.
5. Replace Pre-filter.
6. Replace air purifier in original carton and store in a dry cool place.
7. Order Replacement filters for next use.

Figure 3

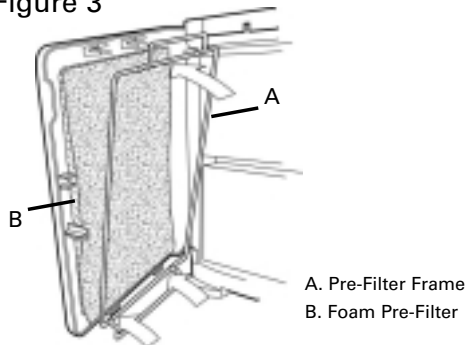

A. Pre-Filter Frame
B. Foam Pre-Filter

TROUBLESHOOTING

Problem

Solution

Unit will not operate.

Check that the unit is plugged in and the electrical outlet or circuit breaker is working.

Make sure the unit is on by turning the power knob.

If the door is ajar the unit will not operate. Make sure the filters are properly installed and firmly close the door by pushing on the right side of door.

Decreased air flow.

If the filter life indicator is red, the HEPA filters need to be changed.

If the HEPA filters have not been changed in a year or more, change the HEPA filters.

Ensure carbon filters are changed every 3-6 months.

Check to ensure nothing is blocking air inlet and filtered air outlet.

Wash the pre-filter.

REPLACEMENT ACCESSORY

To order call 1-877-207-0923

- 106773 Replacement SmartAire™ HEPA Filter (1 Pack)
- 106743 Replacement SmartAire™ HEPA Filter (2 Pack)
- 106753 Replacement SmartAire™ Carbon Filter (4 Pack)
- P00633 Replacement Foam Pre-filter (106633)
- P00643 Replacement Foam Pre-filter (106643)
- P00653 Replacement Foam Pre-filter (106653)

WARRANTY INFORMATION

SERVICE INSTRUCTIONS

1. Do NOT attempt to repair or adjust any electrical or mechanical functions on this unit. Doing so will void the warranty.
2. If you have any questions regarding this unit's operation or believe any repair is necessary, please call 1-877-207-0923 to speak with a Customer Service Representative.
3. If you need to exchange the unit, please return it in the original carton, with a sales receipt, to the store you purchased it. If you are returning the unit more than 30 days after the date of purchase, please see the enclosed warranty.
4. If you have any other questions or comments, feel free to write us:

Customer Service Department

P.O. Box 769, Milford, MA 01757-0769

For your own records, staple or attach your sales receipt to this manual. Also, please take a moment to write the store name/location and date purchased below.

STORE NAME

LOCATION:

DATE PURCHASED:

(STAPLE RECEIPT HERE)

FIVE (5) YEAR LIMITED WARRANTY SAVE THIS WARRANTY INFORMATION

What does your warranty cover?

- Any defect in material or workmanship.

For how long after the original purchase?

- 5 years.

What will we do?

- Provide you with a new, or at our option, a reconditioned unit.
- The exchange unit is warranted for the remainder of your product's original five year warranty period.

How do you make a warranty claim?

- Return product to nearest WAL*MART store
- Properly pack your unit. We recommend using the original carton and packing materials.
- Include in the package a copy of the sales receipt or other evidence of date of original purchase. If the unit was a gift, provide a statement specifying the date received. Also print your name and address and a description of the defect.
- Return the product to your nearest WAL*MART store.
- A new or reconditioned unit will be provided.

What does your warranty not cover?

- Customer instruction. This instruction manual provides information regarding operating instructions and user controls. For additional information, ask your dealer.
- Commercial use.
- Damage from misuse, abuse, or neglect.
- Products which have been modified or incorporated into other products.
- Products purchased or serviced outside the USA.

How does state law relate to this warranty?

- This warranty gives you specific legal rights, and you may also have other rights which vary from state to state.

What if you purchased your product in the U.S., Canada or Mexico and encounter a problem while using it outside the country of purchase?

- The warranty is valid only in the country of purchase and if you follow the warranty claim procedure as noted.

 GE is a trademark of General Electric Company and is used under the license by WAL*MART Stores, Inc. Bentonville, AR 72716

Free Manuals Download Website

<http://myh66.com>

<http://usermanuals.us>

<http://www.somanuals.com>

<http://www.4manuals.cc>

<http://www.manual-lib.com>

<http://www.404manual.com>

<http://www.luxmanual.com>

<http://aubethermostatmanual.com>

Golf course search by state

<http://golfingnear.com>

Email search by domain

<http://emailbydomain.com>

Auto manuals search

<http://auto.somanuals.com>

TV manuals search

<http://tv.somanuals.com>