



# *GE Fanuc Automation*

---

*Programmable Control Products*

*Series 90™ -70  
I/O Link  
Interface Module*

GFK-0644A

February 1993

## *Warnings, Cautions, and Notes as Used in this Publication*

### **Warning**

Warning notices are used in this publication to emphasize that hazardous voltages, currents, temperatures, or other conditions that could cause personal injury exist in this equipment or may be associated with its use.

In situations where inattention could cause either personal injury or damage to equipment, a Warning notice is used.

### **Caution**

Caution notices are used where equipment might be damaged if care is not taken.

### **Note**

Notes merely call attention to information that is especially significant to understanding and operating the equipment.

This document is based on information available at the time of its publication. While efforts have been made to be accurate, the information contained herein does not purport to cover all details or variations in hardware or software, nor to provide for every possible contingency in connection with installation, operation, or maintenance. Features may be described herein which are not present in all hardware and software systems. GE Fanuc Automation assumes no obligation of notice to holders of this document with respect to changes subsequently made.

GE Fanuc Automation makes no representation or warranty, expressed, implied, or statutory with respect to, and assumes no responsibility for the accuracy, completeness, sufficiency, or usefulness of the information contained herein. No warranties of merchantability or fitness for purpose shall apply.

The following are trademarks of GE Fanuc Automation North America, Inc.

Alam Master	CIMSTAR	Helpmate	PROMACRO	Series Six
CIMPLICITY	FieldControl	GENet	Logicmaster	Series One
Series 90	CIMPLICITY 90-ADS	Genius	Modelmaster	Series Three
VuMaster	CIMPLICITYPowerTRAC	Genius PowerTRAC	ProLoop	Series Five
Workmaster				

Copyright 1993 GE Fanuc Automation North America, Inc.  
All Rights Reserved

## Content of this Manual

This book is a reference to the features, operation, installation, and configuration of the GE Fanuc Series 90™-70 I/O Link Interface Module (IC697BEM721).

**Chapter 1. Introduction:** Describes the functions and features of the Series 90-70 I/O Link Interface Module.

**Chapter 2. Installation:** Includes basic setup procedures.

**Chapter 3. Series 90-70 PLC Configuration:** Shows how to add an I/O Link Interface Module to the Series 90-70 PLC system.

**Chapter 4. Series 90-70 PLC Programming:** Explains how to configure, monitor, and control the I/O Link Interface Module.

## Related Publications

*Logicmaster 90-70 Users's Manual* (GFK-0263). Reference manual for system operators and others using the Logicmaster 90-70 software to program, configure, monitor, or control a Series 90-70 PLC and/or a remote drop.

*Power Mate Connection, Programming, Maintenance Manual* (GFZ-61613). Reference manual to setting up, programming, operating, and maintaining a Power Mate system.

*Series Zero Connection Manuals.* For 0 and 00-TC, TE, TTC, MC, ME, GCC, GSC, and PC controls, the connection manual is GFK-61393. For 0-L and 00-L controls, the connection manual is GFZ-61573.

*Series Zero Operator Manuals.* For 0 and 00-TC, TE, TTC, and GCC controls, the operator manual is GFZ-61394. For 0 and 00-MC, ME, and GSC controls, the operator manual is GFZ-61404. For 0-PC and 00-PC controls, the operator manual is GFZ-61594. For 0-L and 00-L controls, the operator manual is GFZ-61574.

*Series 15 Connection Manual* (GFZ-61213E).

*Series 15 Operator/Programming Manual* (GFZ-61213E).

*Series 16 Connection Manual* (GFZ-61874E).

*Series 16 Operator Manuals.* For the 16-MA control, the operator manual is GFZ-61874. For 16-TA and 16-TTA controls, the operator manual is GFZ-61804.

*Series 16 Maintenance Manual* (GFZ-61805).

## We Welcome Your Comments and Suggestions

At GE Fanuc automation, we strive to produce quality technical documentation. After you have used this manual, please take a few moments to complete and return the Reader's Comment Card located on the next page.

*Jeanne Grimsby*  
senior technical writer

<b>Chapter 1</b>	<b>Introduction</b> .....	<b>1</b>
	System Overview .....	1
	Application Software .....	3
	Module Description .....	4
	Module Specifications .....	5
	Cable Types for the I/O Link .....	6
	Optical Adapter .....	8
	Operation of the I/O Link .....	9
	Getting Started .....	14
 <b>Chapter 2</b>	 <b>Installation</b> .....	 <b>15</b>
	Installing the I/O Link Interface Module in the Rack .....	15
	Removing the I/O Link Interface Module from the Rack .....	16
	Connecting the I/O Link Interface Module to Other Devices .....	17
	Serial Port Pin Assignments .....	18
	Optical Adapter Installation .....	20
 <b>Chapter 3</b>	 <b>Logicmaster 90-70 Configuration</b> .....	 <b>21</b>
 <b>Chapter 4</b>	 <b>Programming Guide</b> .....	 <b>23</b>
	Overview .....	23
	Selecting a Program Block .....	24
	Adding the Program Block Logic to an Application Program .....	24
	Calling the Program Block .....	25
	Program (%P) References for the I/O Link Program Blocks .....	26
	Global (%G) References for the I/O Link Program Blocks .....	27
	Configuring I/O Links .....	28
	Controlling the I/O Link Module .....	30
	Monitoring Link Operation .....	32

# Chapter 1

## Introduction

### System Overview

The Series 90-70 I/O Link Interface Module (IC697BEM721) is used to interface a Series 90-70 PLC to GE Fanuc and Fanuc products which may also be placed on the proprietary Fanuc I/O Link. The Fanuc I/O Link is a serial interface that provides high-speed exchange of I/O data between a master device and up to 16 slaves.

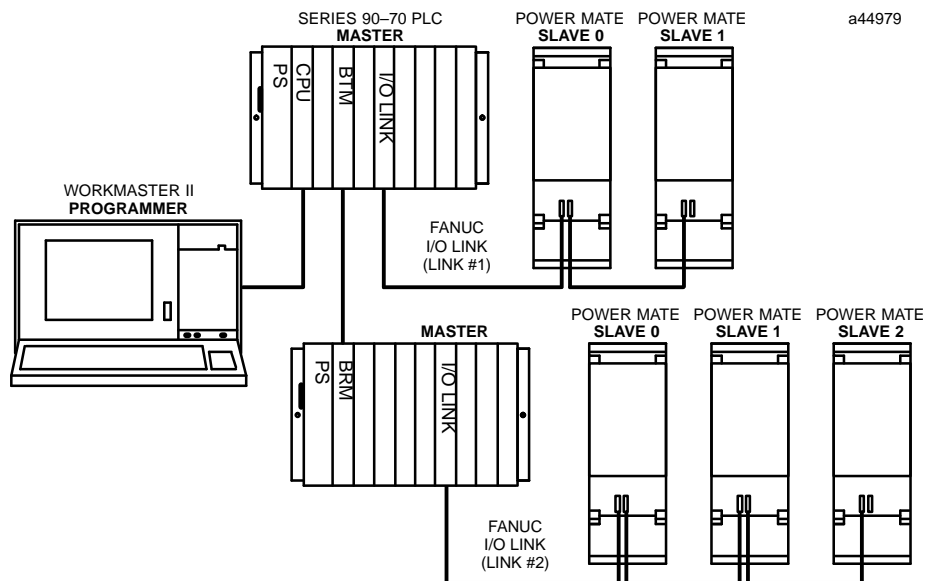

Up to four I/O Link Interface Modules can be installed in a Series 90-70 PLC. They can be located in the CPU rack and in expansion racks. Each I/O Link Interface Module can be used in either master or slave mode.

Two I/O Link Interface Modules are shown in the example system illustrated above—one in the CPU rack and the other in an expansion rack. Each module is set up as a master with its own I/O Link. In this example, both of the I/O Link Interface Modules exchange data with Power Mate CNCs. Usually, when there are multiple I/O Link Modules in the same PLC, they are on separate I/O Links as shown here. However, it is possible to have more than one I/O Link Interface Module in the Series 90-70 connected to the same link, if that suits the needs of the application.

## Master or Slave Operation

When used as a master, an I/O Link Interface Module can receive up to 1024 discrete inputs from devices on the I/O Link, and send up to 1024 discrete outputs. Potential slave devices include the Series 90-30 PLC and the Power Mate CNC.

When used as a slave, the Series 90-70 I/O Link Interface Module can receive up to 64 discrete inputs from the master, and send up to 64 discrete outputs. The master may be another Series 90-70 PLC, a Series 15, Series 16, or Series 18 CNC, a Series 0 Model C CNC, or an F-D Mate CNC. The Series 90-70 PLC and Series 0 CNC can be used as either master or slave.

In the example system shown below, the Series 90-70 PLC shown at the top functions as an area controller for three machine cells. The area controller has two I/O Link Interface Modules, each of which operates as an I/O Link master.

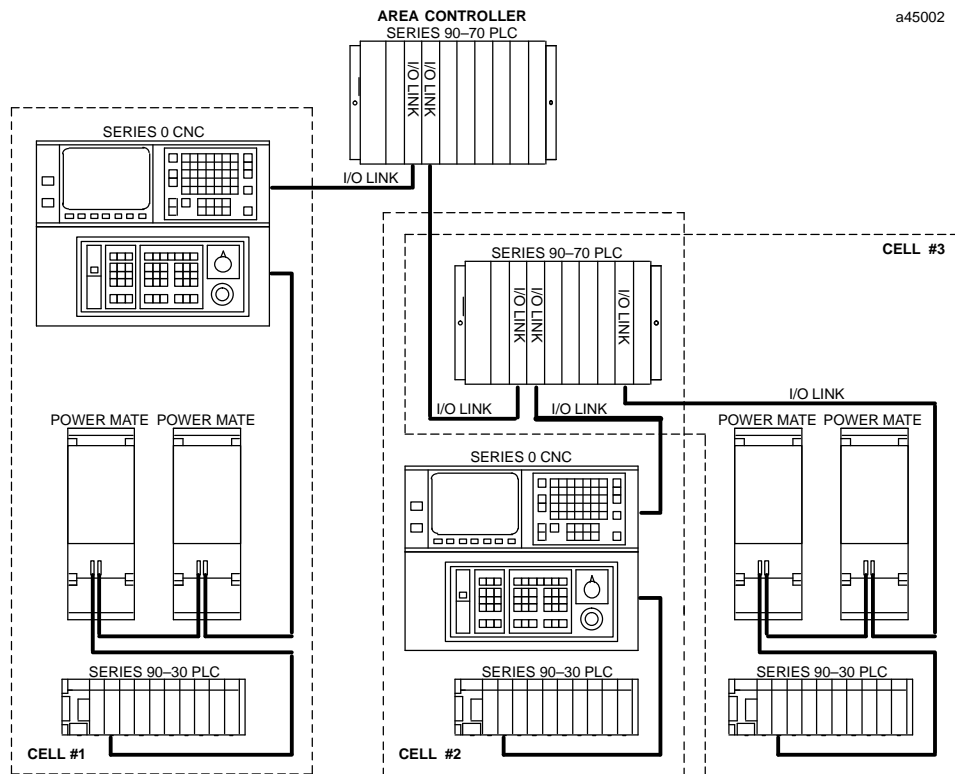

In this system, the left I/O Link from the area controller goes to cell 1, where a Series 0 CNC, two single-axis Power Mate CNCs, and a Series 90-30 PLC are the slaves. They control the operations of a large machine and its auxiliary equipment. The right I/O Link from the area controller goes to another Series 90-70 PLC. That PLC serves as a slave on the link to the area controller, and as a master on two other links to smaller machine cells. In cell 2, a Series 0 CNC and a Series 90-30 PLC are the slaves. In machine cell 3, the slaves are a Series 90-30 PLC and two Power Mate CNCs.

---

## Application Software

The Series 90–70 I/O Link Interface Module is provided with two application software diskettes (catalog number IC641SWP708), a 3-inch and a 5-inch diskette. The content of these diskettes is the same.

This application software can be used to integrate up to four I/O Link Interface Modules into the PLC's application program. There are three Program Blocks on a diskette. Each will transfer I/O data between the module and the PLC, perform diagnostics functions, and transfer application program commands to the module.

One Program Block is selected as being most appropriate for the application, and added to the application program. Additional application program logic can be created to perform the following functions:

1. To specify the number of I/O Link Interface Modules present in the PLC.
2. To specify, for each I/O Link Interface Module:
  - A. A rack and slot location in the Series 90–70 PLC.
  - B. Master or slave operation.
3. And, for each I/O Link Interface Module that will be a master:
  - A. To assign a data length and I/O addresses for each slave on its link.
  - B. To control operation of the link and monitor module and link status.

Chapter 4 explains how to select the best Program Block for your system, and how to incorporate it in an application program.

# Module Description

An I/O Link Interface Module occupies one module slot in a Series 90-70 PLC rack. It can be installed in any rack, in any slot except rack 0 slot 1, which is reserved for the CPU Module.

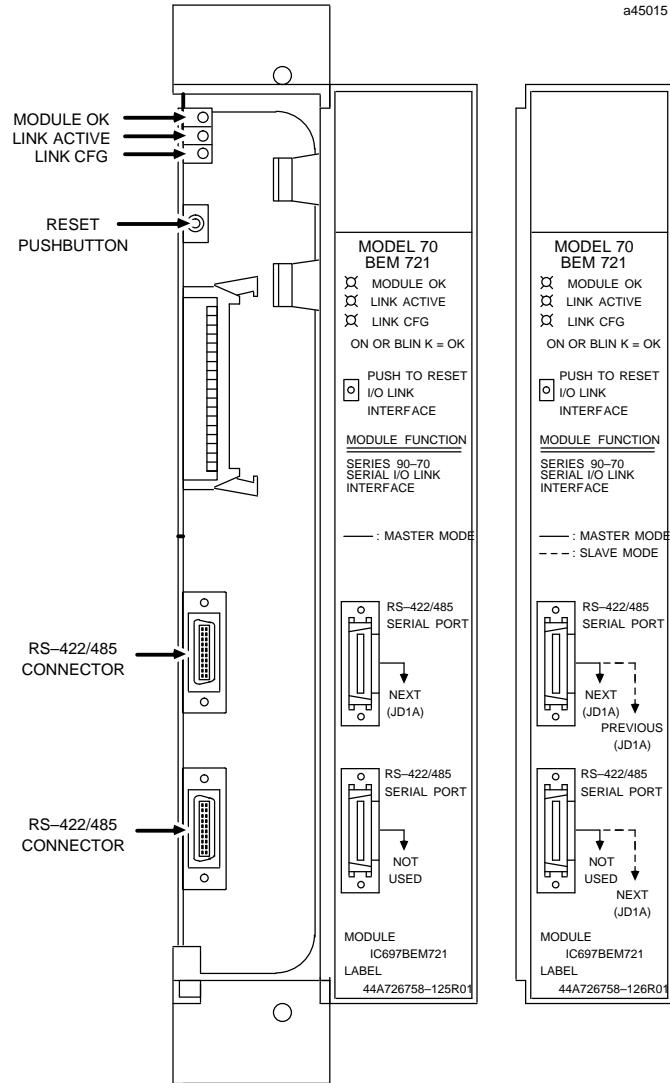

## LEDs

The I/O Link Interface Module has three LEDs that show its operating, configuration, and communications status.

- Module OK:** indicates the module's operating status.
- Link Active:** indicates the module's communications status.
- Link Cfg:** indicates whether I/O Link configuration has occurred.



## Reset Pushbutton

The Reset pushbutton provides a convenient means of reset if a failure occurs. If the module is being used as a master, pushing the Reset button resets both the module and operation of the link. The application program must be used to re-initialize the link. If the module is being used as a slave and a fault has caused the module to stop operating, pushing the Reset button resets the module while the rest of the link continues to function.

### Note

The Reset pushbutton should not be used if the link is operating normally. Pressing Reset during normal operation causes the link to stop operating. The diagnostic program logic interprets this as an external link failure.

## Serial Ports

The front of the module has two 20-pin, D connector, RS-422/485 serial ports. These ports are used for connection to the I/O Link.

## Module Specifications

<b>Physical dimensions:</b>	6.3in x 9.19in (160mm x 233mm). Occupies single slot in Series 90-70 rack.
<b>Module type:</b>	Series 90-70 PLC module, providing I/O Link communications with up to 16 slave devices in master mode.
<b>Current requirement from +5-volt bus</b>	1.0 Amp without Optical Adapter 0.2 Amp per Optical Adapter
<b>LEDs:</b>	Module OK, I/O Link Active, I/O Link Configured
<b>Pushbutton:</b>	Reset I/O Link
<b>I/O Points:</b>	
In master mode	1024 inputs, 1024 outputs maximum
In slave mode	64 inputs, 64 outputs maximum
<b>Environmental:</b>	
Operating temperature	0°C to +60°C (32°F to +140°F)
Storage temperature	-40°C to +85°C (-40°F to +185°F)
Humidity	5% to 95% (non-condensing)
Vibration and shock	3.5mm displacement 5-9Hz 1 G 10-200Hz 15G for 11mS duration
<b>RS-422/485 Serial Ports:</b>	1.5 MHz transmission rate.

## Cable Types for the I/O Link

The following cables and connectors can be used to complete the I/O Link between devices.

Item	CatalogNumber	Vendor	Description
Cable	A03B-0807-K801	GE Fanuc	5 meter length with connectors on both ends. Connects between master and slave device, or between two slave devices.
Cable	A03B-0807-K802	GE Fanuc	10 meter length with connectors on both ends. Connects between master and slave device, or between two slave devices.
Cable	AMW2076	OKI Electric Cable	10-pair shielded cable without connectors, for making custom-length cable. Connects between master and slave device, or between two slave devices.
Connector	A02B-0120-K301	GE Fanuc	20-pin connector with solder lug. Consists of the two following parts.
Connector	PCR-E20FS	Honda	20-pin female connector with solder lug.
	PRC-V20L	Honda	Connector cover.
Cable	A03B-0807-K803	GE Fanuc	1 meter length with connectors on both ends. Connects between master or slave and Optical Adapter. This cable can only be used with an Optical Adapter; do not use it for master/slave or slave/slave connections.
Optical Adapter	A138-154-B001	GE Fanuc	Required for optical fiber cable.
Cable	A66L-6001-009	GE Fanuc	Optical fiber cable for use with Optical Adapter:
	" #L10R03		10m
	" #L15R03		15m
	" #L20R03		20m
	" #L30R03		30m
	" #L40R03		40m
	" #L50R03		50m
	" #L60R03		60m
	" #L80R03		80m
	" #L90R03		90m
	" #L100R03		100m

## Cable Lengths on the I/O Link

The maximum distance between the master and the first slave, and between successive slaves, depends on whether electrical or optical cable is used.

- The maximum length of an electrical cable link is 10 meters (33 feet).
- The maximum length of an optical fiber cable is 100 meters (330 feet).

Electrical and optical cables can be used in the same I/O Link.

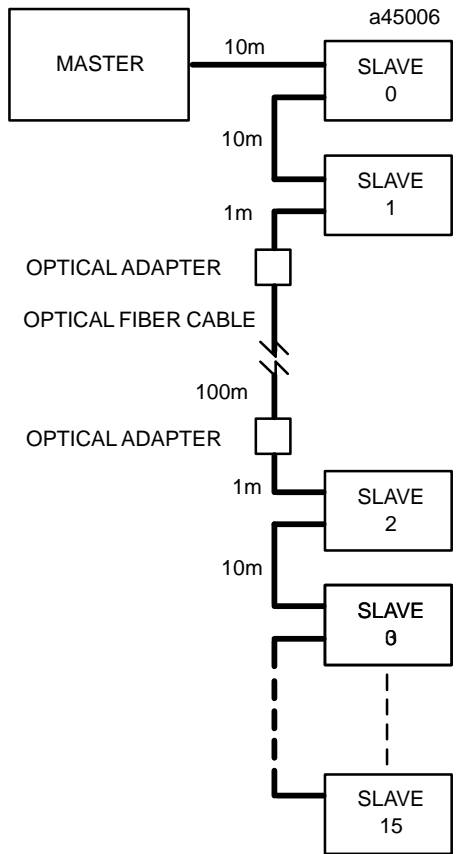

## Optical Adapter

An Optical Adapter (A138-154-B001) can be used to interface the electrical cable of the I/O Link with optical cable.

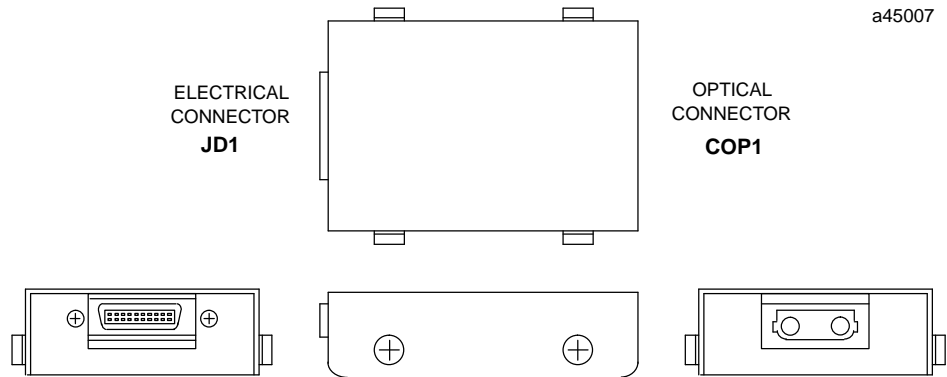

Use pairs of adapters in applications where:

- distances of up to 100 meters (330 feet) are required between any two devices on the I/O Link.
- the I/O Link runs between different cabinets, and it is not possible to connect the cabinets with a wire of 5.5mm<sup>2</sup> or thicker.
- excessive electromagnetic noise may affect the cable. This includes noise from machinery such as a welding machine, and noise-generating cable such as power cable that runs for long distances with the I/O Link cable.

# Operation of the I/O Link

The I/O Link consists of a full duplex communications channel. Physically, the link consists of two twisted pairs of wire and a signal ground conductor. These wires are contained in a cable that has an over-all shield. Signals are of the differential type and a wire pair is used for each signal. Signal levels are compatible with specification EIA RS-422/RS-485. The signal baud rate is 1.5 Mbaud maximum.

## Input and Output Data

The master on an I/O Link can send 1024 outputs and receive up to 1024 inputs from slave devices. A slave can send and receive either 32 or 64 inputs and outputs. For each link device, inputs and outputs have the same meaning:

- **Input Data** is data received from the link.
- **Output Data** is data sent to the link.

So the *same* set of data is considered output data by the device that sends it and input data by the device that receives it.

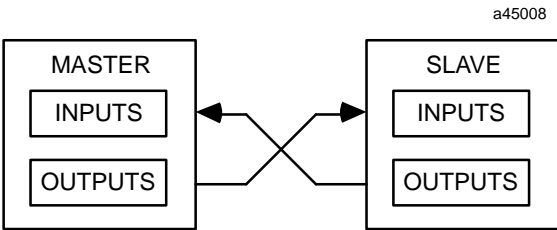

For each Series 90-70 I/O Link Interface Module used as a master, %I and %Q references and data lengths for each slave are assigned within the application Program Block, using Logicmaster 90. Instructions for doing this are given in chapter 4. For other types of devices on the link, references and data lengths are assigned differently. For details on how a specific type of device handles its I/O Link data, you should refer to the User's Manual for that device.

## Data Sent by the Master

The master sends output data for all slave devices together. If a Series 90-70 PLC is the master on an I/O Link, it simply places the data to be sent into the %Q output references assigned to the I/O Link Interface Module.

Slaves receive the data in order of their positions on the link. Each slave in turn reads out its configured amount of data, and passes the remainder on to the next slave. To a slave, data received from the master is input data. If a Series 90-70 PLC is a slave, it obtains the data received from the master by reading the %I input references assigned to the I/O Link Interface Module.

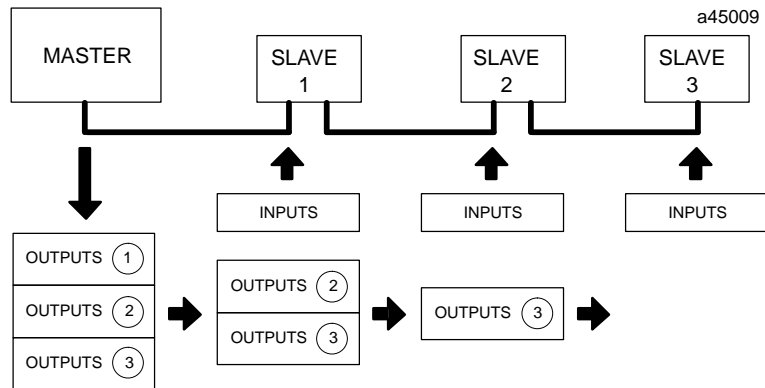

## Data Returned by Slaves

The master continuously reads the output data from each slave. If a Series 90-70 PLC is a slave, it provides this data by placing it into the %Q references configured for the I/O Link Interface Module. If a Series 90-70 PLC is the master, it reads the data from the %I references assigned to the I/O Link Interface Module.

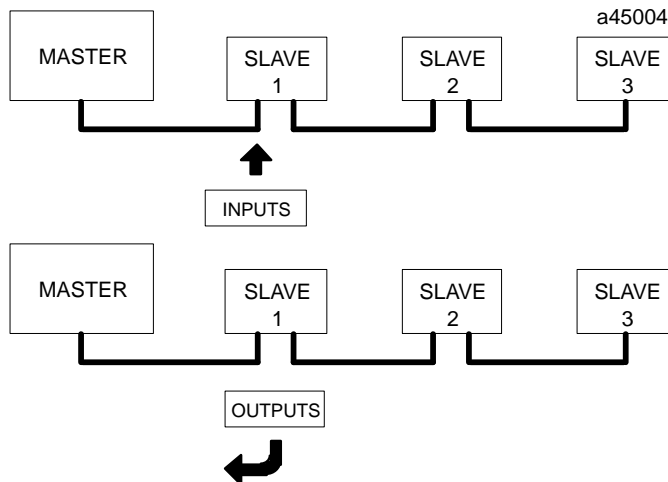

The master identifies each set of data it receives with respect to the slave's position on the link. To the master, data received from slaves is input data.

## Inputs and Outputs Hold Last State

The inputs and outputs *of the I/O Link Interface Module* will hold their last states if one of the following events occurs:

- the link is broken.
- the master resets.
- the slave resets.
- the Series 90-70 PLC is put into STOP mode.
- the Series 90-70 PLC is powered-down.

When the disruption is corrected, the module initializes all inputs and outputs to zero, then quickly resets them to their actual states.

## Faults on the I/O Link

- A. **The Series 90–30 PLC, Series 90–70 PLC, and Power Mate CNC without a separate encoder port** handle faults as described below. The following information applies only if there are no other types of devices on the link.

If one of the following faults occurs, communications stop at the fault location. If there are prior devices on the link, they are still able to transfer data with the master. If there are subsequent devices on the link, however, they cannot.

- Power is removed from any device.
- There is a fault in the I/O Link cable such as an open or shorted wire.
- A module fault, software fault, or hardware fault occurs in the master or slave.

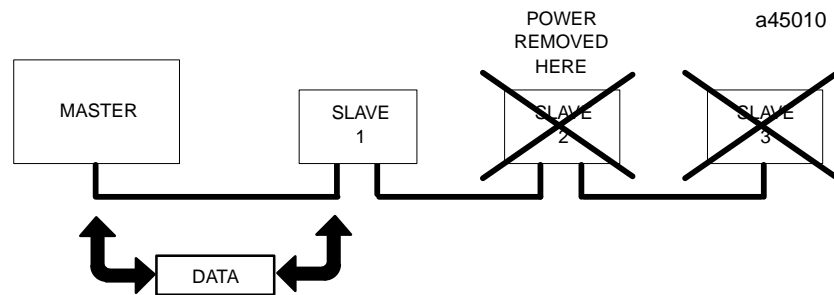

If the master is a Series 90–70 PLC and one of the following faults occurs, communications continue on the rest of the link.

- A slave has been set up for the wrong amount of data.
- A Series 90–30 slave is in Stop mode.
- The sequence of slaves on the link is not the same as the sequence expected by the master.

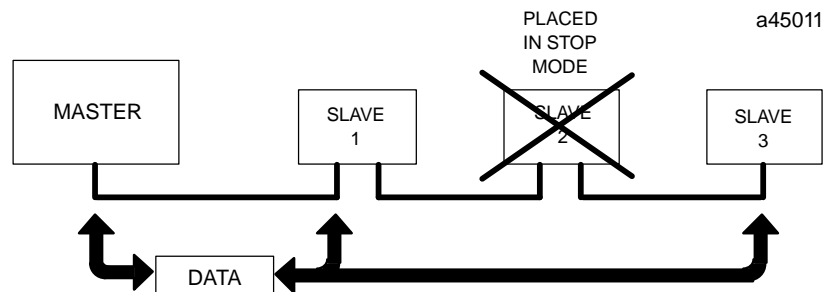

- B. **If the link is connected to any other type of device, including a Power Mate CNC that has a separate encoder port, a fault on any device causes the entire link to shut down as a safety precaution.** If that happens, follow this procedure to restore link operation.

1. Correct the condition that caused the fault.
2. With the master inactive on the link, clear system errors by power cycling each CNC slave (turn power off, then on again).
3. Cycle power to each Series 90–30 I/O Link module, to clear the Logicmaster fault table.
4. Reset the I/O link from the master.



## Diagnostics

The application Program Block automatically provides the Series 90–70 PLC with diagnostic information about the I/O Link Interface Module, and about link operation if the module is operating as a master. The diagnostic information is placed into %P references assigned to that I/O Link Interface Module. Additional program logic can be created to read these %P references for monitoring the following:

- Whether an invalid configuration has been provided during link initialization. The link will not operate until a valid configuration has been supplied.
- Whether the I/O Link Module is operating properly.
- Whether input data is being received.
- Whether a link fault has occurred.

Chapter 4 explains how to add these diagnostics to an application program.

## Link Control

In addition, the Program Block automatically reads other %P references in the Series 90–70 PLC to receive commands from the application program. These %P references can be used to instruct the I/O Link Interface Module to do the following:

- Operate as a master or a slave.
- Disable or enable the input and/or output update between the master and slave(s).
- Start or restart link operation.
- Reset or stop link operation.

Use of these program references is also explained in chapter 4.

---

## Getting Started

To install and configure a Series 90–70 I/O Link Interface Module, follow these basic steps:

### **1. Install the module and complete the I/O Link**

Follow the instructions in chapter 2 to install the Series 90–70 I/O Link Module. After installing the other devices on the link (as instructed in their individual User's Manuals), complete the I/O Link cabling. This is also described in chapter 2.

### **2. Add the I/O Link Module to the Series 90–70 PLC Configuration**

Follow the instructions in chapter 3 to complete the Logicmaster 90 configuration screen for an I/O Link Interface Module.

### **3. Select and install an application Program Block from the diskette**

Chapter 4 explains how to choose the most appropriate Program Block from an application diskette, and how to add it to a Program Folder.

### **4. Complete the program logic for the I/O Link Module**

This is also explained in chapter 4.

# Chapter 2

## Installation

---

---

This chapter tells how to install an I/O Link Interface Module, and how to complete the I/O Link that joins the module to other devices.

### Installing the I/O Link Interface Module in the Rack

The I/O Link Interface Module must not be located to the left of any board that generates interrupts (such as a PCM, Genius Bus Controller, Analog, GENet LAN, or Ethernet module).

#### Caution

**Rack power MUST be OFF when installing or removing the I/O Link Module.**

1. Grasp the module firmly with your hand and insert it into the card guide.
2. Align the module's printed circuit board with the connector on the rack backplane and slide it towards the connector until it has started to seat.
3. Place one thumb on the left side of the top plastic flange and the other thumb on the left side of the bottom plastic flange. Push the board into the connector until the top and bottom latches click onto the rack rails.
4. Visually inspect the board to be sure it has seated properly.

#### Caution

**Make sure no exposed wiring touches any conductive material. Such contact could damage the module, and other units to which it is connected.**

5. *A CPU module must be present in rack 0 slot 1 before applying power to the I/O Link Interface Module.* Turn on power, and observe the LEDs.

LED Name	LED Status	Indication
Module OK	On	The I/O Link Interface Module has passed its powerup diagnostics and the hardware is operating properly.
	OFF	The module has failed a diagnostic test, or a run-time failure has been detected.
Link Active	On	The module is communicating with the I/O Link.
	OFF	A failure has occurred with the I/O Link, and communications are not possible.
Link Cfg	ON	I/O Link configuration has occurred, and the module is ready to communicate.
	OFF	The module has not been configured for link operation.

### Note

If a CPU is powered up for the first time after being received from the factory (or for the first time after its configuration has been cleared or its battery has been removed), and there is an I/O Link Interface Module present in one of the racks of the PLC, a “Loss of Module” diagnostic is generated in the PLC.

To proceed, clear the fault and download a configuration to the CPU. See chapter 3 for configuration instructions. Once the CPU has been configured, the “Loss of Module” diagnostic will only occur if the module subsequently fails or is removed.

## Removing the I/O Link Interface Module from the Rack

1. Remove power from the rack.
2. Squeeze the rack clips on the back of the cover to disengage the clips from the rack rail.
3. Pull the module firmly to remove it from the backplane connector.
4. Slide the board along the card guide and remove it from the rack. Avoid contact with neighboring boards and wiring.

## Connecting the I/O Link Interface Module to Other Devices

Using the appropriate cable, connect the devices on the I/O Link. Notice that the cables are marked JD1A on one end and JD1B on the other.

### Ports on the I/O Link Module

The functions of the ports on the I/O Link Interface Module depend on whether the module is used as a master or as a slave.

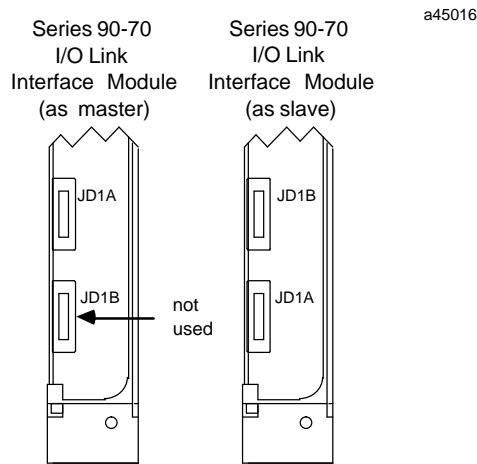

If the system also includes a Series 90-30 PLC, you will notice that the port functions for the Series 90-30 I/O Link Interface Module are the same as the port functions on the Series 90-70 I/O Link Interface Module when it is used as a slave.

### I/O Link Module Used as a Master

If the module will be used as a master, connect the cable from the first slave to the upper port. The lower port is not used in master mode.

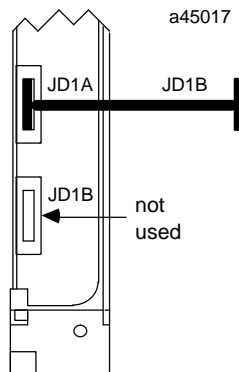

## I/O Link Module Used as a Slave

If the module will be used as a slave, connect the cable from the previous device (either the master or another slave) to the upper port. If the module is followed by another slave on the link, connect the cable from that device to the lower port.

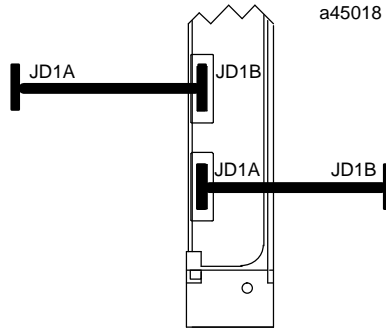

## Order of the Devices on the Link

The devices on an I/O Link must be installed in the order expected by the master. If the Series 90-70 PLC is the master, be sure to connect the devices on a link in the order that agrees with the information provided to the application Program Block.

## Serial Port Pin Assignments

Pin #	Signal	Pin #	Signal
1	SIN	11	0 volts
2	*SIN	12	0 volts
3	SOUT	13	0 volts
4	*SOUT	14	0 volts
5		15	0 volts
6		16	0 volts
7		17	
8		18	+5 volts
9	+5 volts	19	
10		20	+5 volts

The +5-volt output from each connector powers the fiber optic link modules for long distance applications. The +5-volt output is not used otherwise.

## Cable Diagram, No Optical Adapter

The following illustration shows connection details for electrical cable used between a master and slave or between two slave devices. This cable (A03B-0807-K801, A03B-0807-K802, or cable made using AMW 2076 and connectors A02B-0120-K301) does not include the +5-volt signal. Optical Adapter cable, which includes the +5 volt signal, must not be used to directly connect master and slave devices.

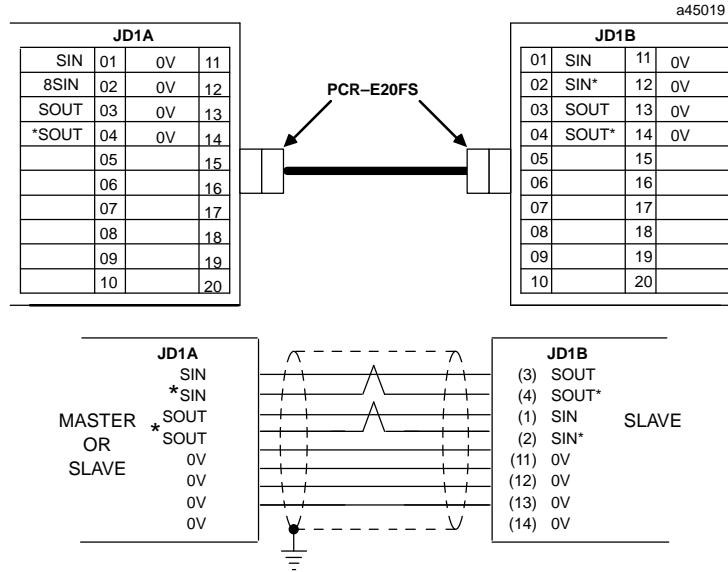

The differential signals, SIN/\*SIN, and SOUT/\*SOUT must be connected using twisted pair wires.

**Caution**

**The I/O Link cable's shield must be connected to chassis ground in your system. Use the grounding cable (44A729227) provided.**

## Optical Adapter Installation

The Optical Adapter is an optional component used to interface the electrical cable to optical cable.

An Optical Adapter must be installed in a sealed enclosure. Avoid contact with other electrical components or wiring, which could short the unit. Use the adapter's casing screws to make earth ground connection. The electrical potential of the earth ground used for the adapter must be the same as that of the I/O Link to which it is connected.

### Cable Connections

Connection between two optical adapters is made using optical fiber cable A66L-6001-009. Lengths of 10 to 100 meters are available. Connect the optical fiber cable to COP1 on the adapter unit.

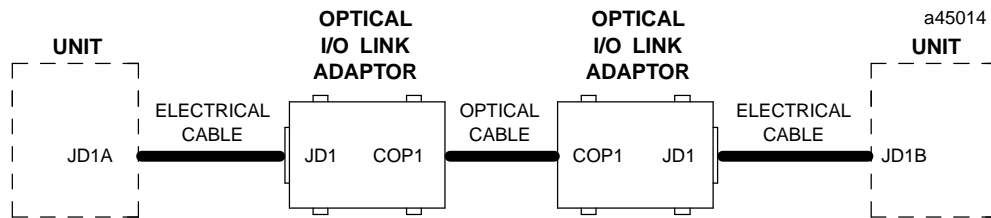

Connection between a master or slave device and an Optical Adapter is made using electrical cable A03B-0807-K803, which is a one-meter cable with connectors on both ends. Connect this cable to JD1 on the adapter. A connection diagram is shown below.

### Cable Diagram, Electrical Cable to Optical Adapter

Cable A03B-0807-K803 provides the +5-volt signal required by the Optical Adapter. Do not use this cable to directly connect master or slave devices; use it only with an Optical Adapter.

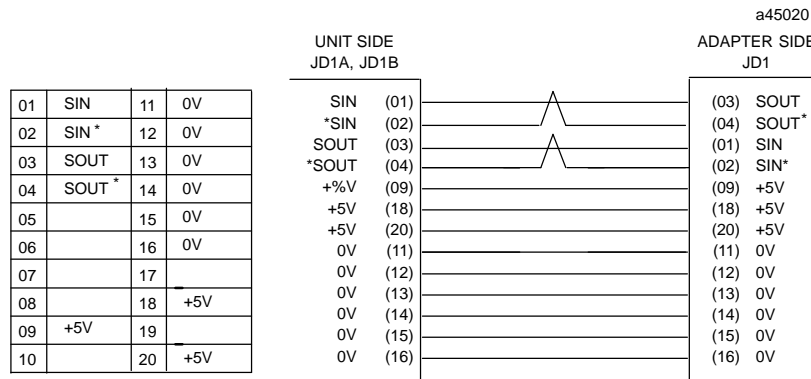

### Note

The +5-volt output on the Series 90-70 I/O Link Module is fused with a 0.5 Amp fuse. The fuse is not field replaceable.



# Chapter 3

## Logicmaster 90-70 Configuration

---

---

This chapter explains the Logicmaster 90–70 software configuration steps related to a Series 90–70 I/O Link Interface Module. For the I/O Link Module, *this configuration only designates the location of the module; it does not assign I/O references. After the module itself has been “installed” using Logicmaster 90, you will set up and initialize the I/O Link as explained in chapter 4.*

### Configuration Steps

1. In the LM90 configuration software, select I/O Configuration.
2. Display the configuration screen for the rack where the module will be located. The Next Page and Prev Page keys are used to move between rack configuration screens.
3. In the correct rack display, move the reverse video cursor to the module’s intended slot. (Use the left and right cursor keys to move the cursor).

### Note

DO NOT locate an I/O Link Interface Module to the left of any board that generates interrupts (such as a PCM, Genius Bus Controller, Analog, GEnet LAN, or Ethernet module).

- 4. If you are using version 4 of Logicmaster, press F1 (vme) to display the catalog list shown below. Select Foreign VME from the list.

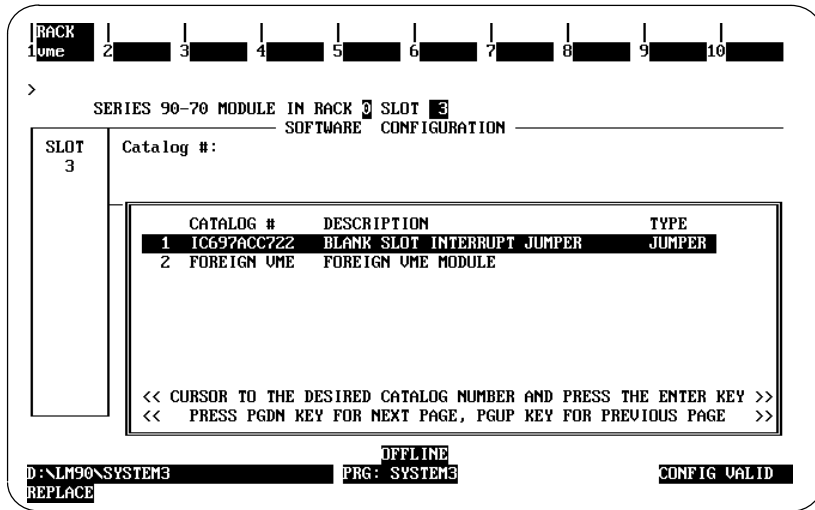

If you are using version 3 of Logicmaster instead press F2 (vme) to display the catalog list. From the list, select Foreign VME (no interrupt).

- 5. No further configuration is required; press Rack (Shift-F1) or the Escape key to return to the rack display.

# Chapter 4

## *Programming Guide*

---

---

This chapter explains how to incorporate logic for one to four I/O Link Interface Modules in an application program for the Series 90–70 PLC. Programming instructions for other devices on the link are not included.

### Overview

The Program Blocks on the diskettes provided with the I/O Link Interface Module will transfer input and output data between the Series 90–70 PLC and up to four I/O Link Interface Modules. The Program Blocks also monitor diagnostics from each I/O Link Interface Module in the PLC, and provide a mechanism for controlling link operation from the application program.

One Program Block is selected for the application, and added to the application program using the Librarian function of Logicmaster 90–70.

Logic must be added to the application program to call the Program Block, which will execute once each time it is called. Normally, it is called once per PLC sweep.

The Program Block utilizes a range of %P references, set aside in PLC memory, to exchange data with the Series 90–70 PLC. The application program interfaces with the Program Block by reading and writing the same %P references. The Program Block also makes use of a small group of %G references. These do not require any application program interaction. However, it is important to be sure that these %G references are not used for any other purpose.

## Selecting a Program Block

There are three Program Blocks on a diskette. Select the Program Block that provides the level of functionality and performance required for the application.

Program Block Identifier	Number of I/O Link Modules	Maximum Number of References	Compatible CPUs
LINK73X	1	512 points	731/732/771/772/81/782
LINK77X	2	2048 points	771/772/81/782
LINK78X	4	4096 points	781/782

The LINK73X Program Block provides the fastest update speed and has the lowest memory requirements, but is limited to a single I/O Link Interface Module per 90-70 system and 512 I/O points. LINK77X provides up to two I/O Link Interface Modules per 90-70 PLC and 2048 I/O points, but it is slightly slower and requires more memory. LINK78X accommodates up to four I/O Link Interface Modules per PLC and provides up to 4096 I/O points. Its update rate is slower than the other two Program Blocks, and it uses more memory.

For the 731/732 CPU, the LINK73X Program Block is required. For the 771/772 CPU, either LINK73X or LINK77X can be used. For the 781/782 CPU, any of the three Program Blocks can be used. Remember that the smaller Program Blocks will give better performance.

## Adding the Program Block Logic to an Application Program

To add a Program Block to an application program, follow these steps:

1. Copy the selected Program Block library file from the diskette to the Logicmaster 90-70 library directory (such as: c:\lm90\p70\p70\_lib).
2. Using the Librarian function (available with Logicmaster 90-70 version 3.0 or later), import the Program Block into the working folder.
3. If the application program will use nicknames for the Program Block %P references (see page 27), include the nicknames in the Variable Declaration Table. The nicknames are provided as three .SDE files in the program folder on the application software diskette: LINK73SX.SDE, LINK77SX.SDE, and LINK78SX.SDE. To include the appropriate file, go to the Variable Declarations in the working folder, select "include", and enter the path and filename (such as: c:\link\link73sx.sde).
4. Complete the application program logic as described on the following pages.

# Calling the Program Block

To call the LINKxxX block, place a Call instruction as close as possible to the start of the main program. To assure consistent mapping of link I/O data, do not use permissive logic to the call. Include at least one call to the LINKxxX block each program sweep, to assure that the link status is routinely updated and the link retry mechanism is enabled. This is discussed in more detail later in the chapter.

## Example Call Instruction

In this example, the Call instruction calls Program Block LINK73X.

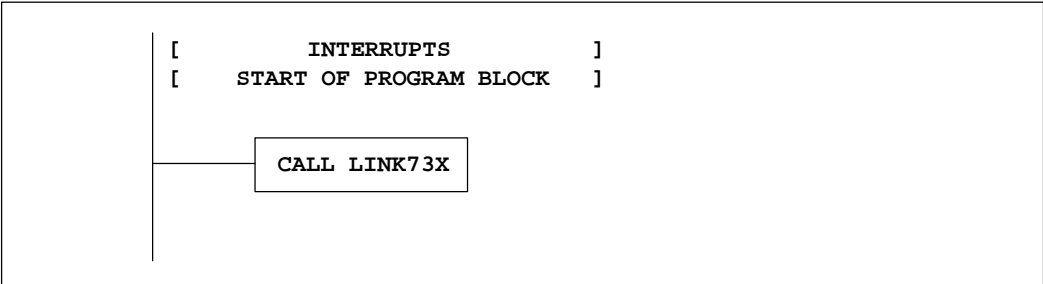

## Using Multiple Calls to the Program Block

For most applications, the main program will include only one Call instruction to the LINKxxX Program Block. However, it is possible to use multiple calls in the program. For example, a call might be used at a particular place in the program to update inputs, outputs, or both. In this way, the Program Block call would serve as a “DoI/O” instruction.

In applications with long communications windows or in Constant Sweep Time mode, a call to LINKxxX might be used at the beginning of the program to update only inputs, with another call at the end to update only outputs.

When using multiple calls to the LINKxxX Program Block, all additional calls after the first should use the set status of the “Link Active” status bit as a permissive to their execution.

## Program (%P) References for the I/O Link Program Blocks

The I/O Link Program Blocks use the program registers (%P) shown below. The references for devices 1 to 15 are used only if the I/O Link Module is a master, and it has more than one slave.

Information in Reference	Program Reference				Nickname			
	%P0001				numlink			
	1stModule		2ndModule		3rdModule		4thModule	
	Program Ref.	Nickname	Program Ref.	Nickname	Program Ref.	Nickname	Program Ref.	Nickname
Rack location # (0-7)	%P0002	L1rack	%P0054	L2rack	%P0106	L3rack	%P0158	L4rack
Slot location # (2-9)	%P0003	L1slot	%P0055	L2slot	%P0107	L3slot	%P0159	L4slot
Status word (see page 32.)	%P0004	L1stat	%P0056	L2stat	%P0108	L3stat	%P0160	L4stat
Control word (see page 30.)	%P0005	L1cntrl	%P0057	L2cntrl	%P0109	L3cntrl	%P0161	L4cntrl
Device 0 (or I/O Link Module used as slave), slave data length (32 or 64)	%P0006	L1dev0	%P0058	L2dev0	%P0110	L3dev0	%P0162	L4dev0
" slave start address of %I	%P0007	L1dev0I	%P0059	L2dev0I	%P0111	L3dev0I	%P0163	L4dev0I
" slave start address of %Q	%P0008	L1dev0Q	%P0060	L2dev0Q	%P0112	L3dev0Q	%P0164	L4dev0Q
Device 1, slave data length (32 or 64)	%P0009	L1dev1	%P0061	L2dev1	%P0113	L3dev1	%P0165	L4dev1
" slave start address of %I	%P0010	L1dev1I	%P0062	L2dev1I	%P0114	L3dev1I	%P0166	L4dev1I
" slave start address of %Q	%P0011	L1dev1Q	%P0063	L2dev1Q	%P0115	L3dev1Q	%P0167	L4dev1Q
Device 2, slave data length (32 or 64)	%P0012	L1dev2	%P0064	L2dev2	%P0116	L3dev2	%P0168	L4dev2
" slave start address of %I	%P0013	L1dev2I	%P0065	L2dev2I	%P0117	L3dev2I	%P0169	L4dev2I
" slave start address of %Q	%P0014	L1dev2Q	%P0066	IL2dev2Q	%P0118	L3dev2Q	%P0170	L4dev2Q
Device 3, slave data length (32 or 64)	%P0015	L1dev3	%P0067	L2dev3	%P0119	L3dev3	%P0171	L4dev3
" slave start address of %I	%P0016	L1dev3I	%P0068	L2dev3I	%P0120	L3dev3I	%P0172	L4dev3I
" slave start address of %Q	%P0017	L1dev3Q	%P0069	L2dev3Q	%P0121	L3dev3Q	%P0173	L4dev3Q
Device 4, slave data length (32 or 64)	%P0018	L1dev4	%P0070	L2dev4	%P0122	L3dev4	%P0174	L4dev4
" slave start address of %I	%P0019	L1dev4I	%P0071	L2dev4I	%P0123	L3dev4I	%P0175	L4dev4I
" slave start address of %Q	%P0020	L1dev4Q	%P0072	L2dev4Q	%P0124	L3dev4Q	%P0176	L4dev4Q
Device 5, slave data length (32 or 64)	%P0021	L1dev5	%P0073	L2dev5	%P0125	L3dev5	%P0177	L4dev5
" slave start address of %I	%P0022	L1dev5I	%P0074	L2dev5I	%P0126	L3dev5I	%P0178	L4dev5I
" slave start address of %Q	%P0023	L1dev5Q	%P0075	L2dev5Q	%P0127	L3dev5Q	%P0179	L4dev5Q
Device 6, slave data length (32 or 64)	%P0024	L1dev6	%P0076	L2dev6	%P0128	L3dev6	%P0180	L4dev6
" slave start address of %I	%P0025	L1dev6I	%P0077	L2dev6I	%P0129	L3dev6I	%P0181	L4dev6I
" slave start address of %Q	%P0026	L1dev6Q	%P0078	L2dev6Q	%P0130	L3dev6Q	%P0182	L4dev6Q
Device 7, slave data length (32 or 64)	%P0027	L1dev7	%P0079	L2dev7	%P0131	L3dev7	%P0183	L4dev7
" slave start address of %I	%P0028	L1dev7I	%P0080	L2dev7I	%P0132	L3dev7I	%P0184	L4dev7I
" slave start address of %Q	%P0029	L1dev7Q	%P0081	L2dev7Q	%P0133	L3dev7Q	%P0185	L4dev7Q
Device 8, slave data length (32 or 64)	%P0030	L1dev8	%P0082	L2dev8	%P0134	L3dev8	%P0186	L4dev8
" slave start address of %I	%P0031	L1dev8I	%P0083	L2dev8I	%P0135	L3dev8I	%P0187	L4dev8I
" slave start address of %Q	%P0032	L1dev8Q	%P0084	L2dev8Q	%P0136	L3dev8Q	%P0188	L4dev8Q
Device 9, slave data length (32 or 64)	%P0033	L1dev9	%P0085	L2dev9	%P0137	L3dev9	%P0189	L4dev9
" slave start address of %I	%P0034	L1dev9I	%P0086	L2dev9I	%P0138	L3dev9I	%P0190	L4dev9I
" slave start address of %Q	%P0035	L1dev9Q	%P0087	L2dev9Q	%P0139	L3dev9Q	%P0191	L4dev9Q
Device 10, slave data length (32 or 64)	%P0036	L1dev10	%P0088	L2dev10	%P0140	L3dev10	%P0192	L4dev10
" slave start address of %I	%P0037	L1dv10I	%P0089	L2dv10I	%P0141	L3dv10I	%P0193	L4dv10I
" slave start address of %Q	%P0038	L1dv10Q	%P0090	L2dv10Q	%P0142	L3dv10Q	%P0194	L4dv10Q
Device 11, slave data length (32 or 64)	%P0039	L1dev11	%P0091	L2dev11	%P0143	L3dev11	%P0195	L4dev11
" slave start address of %I	%P0040	L1dv11I	%P0092	L2dv11I	%P0144	L3dv11I	%P0196	L4dv11I
" slave start address of %Q	%P0041	L1dv11Q	%P0093	L2dv11Q	%P0145	L3dv11Q	%P0197	L4dv11Q
Device 12, slave data length (32 or 64)	%P0042	L1dev12	%P0094	L2dev12	%P0146	L3dev12	%P0198	L4dev12
" slave start address of %I	%P0043	L1dv12I	%P0095	L2dv12I	%P0147	L3dv12I	%P0199	L4dv12I
" slave start address of %Q	%P0044	L1dv12Q	%P0095	L2dv12Q	%P0148	L3dv12Q	%P0200	L4dv12Q
Device 13, slave data length (32 or 64)	%P0045	L1dev13	%P0097	L2dev13	%P0149	L3dev13	%P0201	L4dev13
" slave start address of %I	%P0046	L1dv13I	%P0098	L2dv13I	%P0150	L3dv13I	%P0202	L4dv13I
" slave start address of %Q	%P0047	L1dv13Q	%P0099	L2dv13Q	%P0151	L3dv13Q	%P0203	L4dv13Q
Device 14, slave data length (32 or 64)	%P0048	L1dev14	%P0100	L2dev14	%P0152	L3dev14	%P0204%	L14dev14
" slave start address of %I	%P0049	L1dv14I	%P0101	L2dv14I	%P0153	L3dv14I	P0205	L4dv14I
" slave start address of %Q	%P0050	L1dv14Q	%P0102	L2dv14Q	%P0154	L3dv14Q	%P0206	L4dv14Q
Device 15, slave data length (32 or 64)	%P0051	L1dev15	%P0103	L2dev15	%P0155	L3dev15	%P0207	L4dev15
" slave start address of %I	%P0052	L1dv15IL1d	%P0104	L2dv15I	%P0156	L3dv15I	%P0208	L4dv15I
" slave start address of %Q	%P0053	v15Q	%P0105	L2dv15Q	%P0157	L3dv15Q	%P0209	L4dv15Q

## Using Nicknames for the %P References

If you want to use the %P nicknames listed in the table, add them to the Variable Declaration Table (see page 24).

## Global (%G) References for the I/O Link Program Blocks

The %P references listed in the previous table are used for link configuration, control, and monitoring. They will be included in the application program as explained on subsequent pages.

An I/O Link Program Block also uses certain %G references for its own operations. These %G references should *not* be included in the application program. They should be reserved for the exclusive use of the Program Block.

Program Block Identifier	%G References to be Reserved
LINK73X	%G1025 – %G1040
LINK77X	%G1025 – %G1040 %GA1025 – %GA1040 %GB1025 – %GB1040
LINK78X	%G1025 – %G1040 %GA1025 – %GA1040 %GB1025 – %GB1040 %GC1025 – %GC1040 %GD1025 – %GD1040

## Configuring I/O Links

In the application program, use Move and Block Move instructions to configure the I/O Links in the system by placing the required data in the appropriate %P program references.

### Configuration Logic, Example

Use Move instructions to supply the number of I/O Link Interface Modules (1), and the rack location (0), and slot location (5) of that module.

```

+-----+
+-----+MOVE+-----+MOVE+-----+MOVE+-----+
|         |INT|         |INT|         |INT|         |
|CONST --+IN Q+-%P00001  CONST --+IN Q+-%P00002  CONST --+IN Q+-%P00003
|+00001  |LEN|         |+00000  |LEN|         |+00005  |LEN|         |
|         |00001|         |         |00001|         |         |00001|         |
+-----+
+-----+
+-----+

```

Block Move instructions can supply the data lengths and beginning %I and %Q addresses for six slaves on the link, which is link 1 in this example.

```

+-----+
+-----+BLKMV+-----+BLKMV+-----+BLKMV+-----+
|         |INT|         |INT|         |INT|         |
|CONST --+IN1 Q+-%P00006  CONST --+IN1 Q+-%P00012  CONST --+IN1 Q+-%P00018
|+00032  |LEN|         |+00032  |LEN|         |+00032  |LEN|         |
|         |00001|         |         |00001|         |         |00001|         |
|
|CONST --+IN2           |CONST --+IN2           |CONST --+IN2           |
|+00001  |             |+00097  |             |+00151  |             |
|
|CONST --+IN3           |CONST --+IN3           |CONST --+IN3           |
|+00001  |             |+00097  |             |+00151  |             |
|
|CONST --+IN4           |CONST --+IN4           |CONST --+IN4           |
|+00064  |             |+00032  |             |+00064  |             |
|
|CONST --+IN5           |CONST --+IN5           |CONST --+IN5           |
|+00033  |             |+00129  |             |+00215  |             |
|
|CONST --+IN6           |CONST --+IN6           |CONST --+IN6           |
|+00033  |             |+00129  |             |+00215  |             |
|
|CONST --+IN7           |CONST --+IN7           |CONST --+IN7           |
|+00000  |             |+00000  |             |+00000  |             |
+-----+
+-----+
+-----+

```

The first Block Move configures the length and beginning %I and %Q addresses of devices 0 and 1. The second Block Move configures devices 2 and 3. The third Block Move configures devices 4 and 5. To simplify programming, IN7 in these Block Moves is not used. If there were more I/O Links, or more devices on link 1, they would be configured in the same manner.



## Configuration Guidelines

To configure the I/O Link(s) in a PLC system, enter constant data values into the appropriate %P registers. These values determine:

- The number of I/O Link Interface Modules in the PLC.
- The rack and slot location of each I/O Link Interface Module.
- The data length for each slave device (32 or 64 for a Power Mate).
- The beginning address in PLC %I memory for input data.
- The beginning address in PLC %Q memory for output data.

This must be done before the start command is issued to any I/O Link Interface Module (as explained later in this chapter).

Program references for the I/O Link Program Blocks are listed in the table opposite.

### ***Specify the Number of I/O Link Modules***

The total number of modules specified in %P must be compatible with the Program Block being used:

- A. for LINK73X, %P00001 must be 1
- B. for LINK77X, %P00001 may be 1 or 2
- C. for LINK78X, %P00001 may be 1 to 4

### ***Configuring the I/O Link Module as a Master***

If the I/O Link Interface Module is a master, specify a data length and references for each slave on the I/O Link. The data length (I/O count) for each device must be 0, 32, or 64. No other values are correct.

The starting %I and %Q addresses must be compatible with the Program Block being used:

- A. for LINK73X, the range is (1 to 481) or (1 to 449)
- B. for LINK77X, the range is (1 to 2017) or (1 to 1985)
- C. for LINK78X, the range is (1 to 4065) or (1 to 4033)

Configure all devices to have consecutive numbers; do not leave any “holes” in the configuration for a module. If a 0 is configured for a slave’s data length, the data lengths of all subsequent slaves on the same link must also be 0.

## Note

All %P references from %P0009 through %P0209 *which are not used for the application* must be set to 0 before the link is activated.

Configure all %I and %Q starting addresses at word boundaries.

### ***Configuring the I/O Link Module as a Slave***

If the module is a slave, configure it to be Device 0. Specify its data length (32 or 64) and references.

Assign a starting %I and %Q address for the module that is compatible with the Program Block being used. The %I and %Q addresses must begin on word boundaries. Set to 0 the unused %P references for devices 1 through 15. See “Configuring the I/O Link Module as a Master”, above.

## Controlling the I/O Link Module

Operation of the module is controlled by setting or clearing bits in the control word, which is located at:

- %P00005 for link 1
- %P00057 for link 2
- %P00109 for link 3
- %P00161 for link 4

The bits in the control word for each I/O Link Interface Module contain the following information:

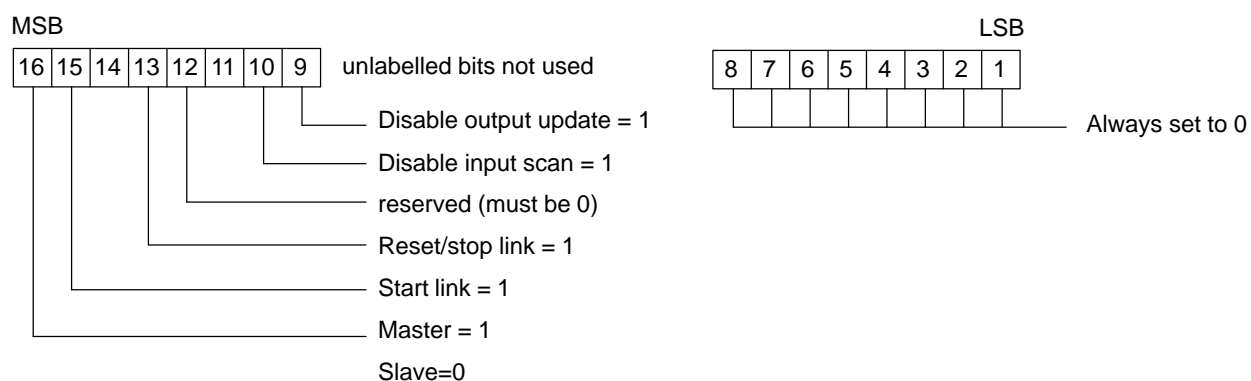

These are one-shot commands. Do not repeatedly write to these bits—that would unnecessarily increase program PLC sweep time and cause unexpected link results.

### Set Master or Slave Mode (bit 16)

Set the most significant bit of the control word as part of the configuration routine that loads all of the other %P registers with the correct values. To use the module as a master, set this bit to 1. To use the module as a slave, set it to 0.

### Start/Restart (bit 15)

After loading a valid configuration into the appropriate %P registers, write a 1 into control bit 15 using a one-shot permissive. The module confirms receipt of the start command by resetting this bit to a 0.

If the module is being used as a master, setting this bit to 1 starts the module and the link. It can also be used to restart the link after a link reset has occurred.

If the module is being used as a slave, use this bit to start or restart the module itself (not the link).

### Reset or Stop (bit 13)

To stop or reset the module, write a 1 to control bit 13, using a one-shot permissive. The module confirms receipt of the command by resetting bit 13 to a 0. The status shows Error Code 6, indicating that a reset was issued and the fault bit was not set.

If the module is a master, this bit resets or stops both the module and the I/O Link. If the module is a slave, setting this bit to 1 resets or stops only the module itself, not the I/O Link.

### Disable or Enable the Input Update (bit 10)

To disable the input update portion of the I/O scan, write a 1 to control bit 10. This might be done during program debugging, or if the program uses multiple calls to the LINKxxX Program Block. Disabling the input update causes the module to ignore new inputs it receives. To re-enable input updates, clear control bit 10 by writing a 0 to it.

Remember that input data is considered to be output data by the device that sends it (see page 26 for an explanation of input and output data).

If the module is a master, setting this bit to 1 causes all input references assigned to devices on the link to hold their last states. The slaves continue to send data to the master, but the new data is ignored by the master; no data is written to the input table.

If the module is a slave, setting this bit to 1 causes the input references assigned to the module to hold their last states. The master continues to send data to the slave, but the new data is ignored by the slave. No data is written to the input table.

### Disable or Enable the Output Update (bit 9)

Disabling the output update keeps the module from *updating* outputs; it does not keep the module from *sending* them. If outputs are disabled, the module keeps sending its last set of output data repeatedly. This might be desirable during program debugging, or if the program uses multiple calls to the Program Block.

Remember that output data is considered to be input data by the device that receives it.

To disable the output update, write a 1 to control bit 9. To re-enable output updates, clear control bit 9 by writing a 0 to it.

If the module is a master, disabling the output update means that no new data will be sent to any slaves on the link. They will continue to receive the same set of data from the master repeatedly.

If the module is a slave, disabling the output update means that no new data will be sent to the master. It will continue to receive the same set of data from that specific slave repeatedly.

## Monitoring Link Operation

For each link, the Program Block uses a specific program register (%P) for status data. These are:

- %P00004 for link 1
- %P00056 for link 2
- %P00108 for link 3
- %P00160 for link 4

Monitor the status word for information about:

- A. the operation of the interface module
- B. the operation of the link
- C. detailed error codes to help diagnose problems

Bits in the status word for an I/O Link contain the following information:

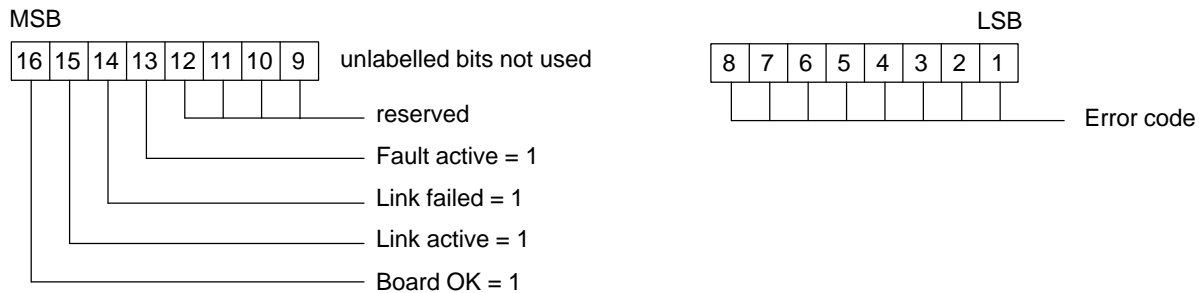

Bits 9 to 12 of the status word are reserved; they should be zeros.

### Monitor the Module (bit 16)

This bit shows the status of module operation, and of link operation if the module is a master. The application program should monitor this bit. If it is 0, the program should take appropriate action such as ignoring any I/O or status information from the module.

The Program Block automatically sets bit 16 to 1 when the module passes its powerup diagnostics, the correct rack and slot are placed in the %P configuration registers, and VME backplane communications have been established.

The Program Block resets bit 16 to 0 if a module hardware fault is detected, or backplane communications are interrupted.

Pressing the I/O Link Interface Module's Reset pushbutton does *not* clear this bit. The Program Block will only try to reinitialize the module after completing powerup diagnostics. *An automatic retry will occur only after link faults; the user must restart the link after a hardware reset.*

### Monitor Communications Status (bit 15)

Monitor status bit 15 to check the status of communications on the link. If this bit is a 0, input data is NOT being received, and appropriate action should be taken. The Program

Block automatically sets this bit to 1 shortly after the application program sets control bit 15 (start bit) to a 1.

If the module is a master, bit 15 is 1 if all link devices are providing input data and are ready to receive output data. The Program Block automatically resets this bit to a 0 if any link fault occurs.

If the module is a slave, bit 15 is 1 if the module is ready to exchange data with the master.

### Monitor for Link Failure (bit 14)

If the module is a master, after a link fault occurs, and the specified number of retries have failed, the Program Block sets this bit to a 1. It is necessary to manually intervene to find the cause of the failure. Look at the error code in the least significant byte of the status word. Error codes are listed in the next table.

After the problem is corrected, reinitialize and restart the link. The Program Block automatically clears status bit 13 when a restart is attempted.

### Monitor for an Invalid Configuration or Link Fault (bit 13)

The application program should monitor this bit to verify operation of the I/O Link.

If status bit 13 is a 1, either an invalid configuration was provided during link initialization, or a fault has occurred on an active link. The Program Block sets this bit to a 1 immediately after the problem occurs.

If the problem occurs during initialization, initialization stops. It will be necessary to enter a valid configuration into the %P registers before initialization can continue. The error code in the least significant byte of the status word will indicate what the configuration problem is.

If the module is a master and the problem is an active link fault, the Program Block automatically tries to restart the link the specified number of times.

The Program Block automatically clears this bit when the link becomes active again. *If this bit continually cycles on and off, the link wiring and devices should be inspected. The application program can keep track of the number of link faults over time, and take appropriate action if too many faults occur.*

## Error Codes: Troubleshooting

The less significant byte of an I/O Link status register contains an error code supplied by the Program Block. Error codes are listed below and on the next page.

Error Code	Description of Error	Recommended Action
0	No error	None
1	I/O Link module hardware fault	Reset the module by pressing the pushbutton or cycling power. If the problem persists, replace the module.
2	External I/O Link failure	This fault can be caused by pressing the Reset pushbutton while the link is operating. If that is not the cause, inspect all cabling and examine carefully each link device. Reset the link. If the problem persists, remove devices from the link one at a time to isolate the defective unit. This error code may also be caused by a hardware problem on the I/O Link Interface Module.
3	Configuration error	Try to reinitialize the link interface. If the problem persists, contact the GE Fanuc PLC service hotline (phone number: 1-800-978-5747).
4	Link interface is not responding	Check that the I/O Link Interface Module is installed in the rack and slot location specified in the %P configuration data. Also determine if the module is inserted completely in the backplane, and the VME bus is operating to other modules in that rack. Make sure that the Logicmaster configuration has been correctly completed for the module as described in chapter 4. Reset the module by cycling power on the rack. If the problem persists, replace the link module.
6	Link Reset	This code indicates that a reset has occurred, or that the application program has reset the link by writing a 1 to control bit 13. The fault bit (status bit 12) is not set. The I/O Link Module automatically resets control bit 13 to 0 to acknowledge that it has received the command.
9	Invalid Number of I/O Link Modules	This code means that the number of I/O Link Interface Modules is not in the range of 0-2 or 0-4, as specified in program reference %P0001.

## Configuration Error Codes

Error Codes 10 to 91, listed below, describe configuration errors. If the I/O Interface Module is being used as a slave, only Error Codes 10, 11, 12, 28, and 44 are used.

Error Code	Description of Error	Recommended Action	Error Code	Description of Error	Recommended Action	
10	Invalid rack ID	Must be in range 0-7	44	Dev. 0, invalid %Q starting address	Must not be greater than maximum I/O data length.	
			45	Dev. 1 "		
			46	Dev. 2 "		
			47	Dev. 3 "		
			48	Dev. 4 "		
			49	Dev. 5 "		
			50	Dev. 6 "		
			51	Dev. 7 "		
			52	Dev. 8 "		
			53	Dev. 9 "		
			54	Dev. 10 "		
			55	Dev. 11 "		
			56	Dev. 12 "		
			57	Dev. 13 "		
			58	Dev. 14 "		
			59	Dev. 15 "		
11	Invalid slot ID	Must be in range 2-9	60	Link devices not defined with consecutive addresses	All data length register values must be 0, following the first occurrence of 0.	
12	Dev. 0, Invalid data length	Must be 0, 32, or 64.	61	Dev. 0, configured but not responding.	Link doesn't operate.	
13	Dev. 1 "		62	Dev. 1 "	Link continues to operate with dev. 0	
14	Dev. 2 "					
15	Dev. 3 "					
16	Dev. 4 "			63	Dev. 2 "	Link continues to operate with previous devices.
17	Dev. 5 "			64	Dev. 3 "	
18	Dev. 6 "			65	Dev. 4 "	
19	Dev. 7 "			66	Dev. 5 "	
20	Dev. 8 "			67	Dev. 6 "	
21	Dev. 9 "			68	Dev. 7 "	
22	Dev. 10 "			69	Dev. 8 "	
23	Dev. 11 "			70	Dev. 9 "	
24	Dev. 12 "			71	Dev. 10 "	
25	Dev. 13 "			72	Dev. 11 "	
26	Dev. 14 "			73	Dev. 12 "	
27	Dev. 15 "			74	Dev. 13 "	
			75	Dev. 14 "		
			76	Dev. 15 "		
28	Dev. 0, invalid %I starting address	Must not be greater than maximum I/O data length.	77	1 extra (undefined) device on the link		
29	Dev. 1 "					
30	Dev. 2 "			78		2 extra (undefined) devices on the link
31	Dev. 3 "			79		3 "
32	Dev. 4 "			80		4 "
33	Dev. 5 "			81		5 "
34	Dev. 6 "			82		6 "
35	Dev. 7 "			83		7 "
36	Dev. 8 "			84		8 "
37	Dev. 9 "			85		9 "
38	Dev. 10 "			86		10 "
39	Dev. 11 "			87		11 "
40	Dev. 12 "			88		12 "
41	Dev. 13 "			89		13 "
42	Dev. 14 "			90		14 "
43	Dev. 15 "			91		15 "

## A

Active Link fault, 33  
Address Assignment, 29  
Application software, 3 , 23

## B

Board OK bit, 32

## C

Cable diagrams, 19 , 20  
Cable lengths, 7  
Cables and connectors, 6  
Calling the Program Block, 24  
Catalog Number  
    Grounding Cable, 19  
    Optical Adapter, 6  
Chassis ground, 19  
Communications window time, 24  
Configuration error, 34  
Configuration example, 28  
Configuration, invalid, 33  
Configuration, Series 90 PLC, 21  
Connectors, 4  
Constant Sweep Time CPU mode, 24  
Control bit definitions, 30  
Control the link, 3  
Control word, 26 , 30  
Controlling the I/O Link Module, 30  
CPU module, 15  
CPUs, compatible, 23  
Current requirement, 5

## D

Data length, 3  
Data lengths, 26 , 29  
Data transmission rate, 5

Device numbers, 26  
Diagnostics, 13  
Dimensions, 5  
Disable I/O update bits, 30  
Distance between devices, 7  
DoI/O, 24

## E

Electromagnetic noise, 8  
Error code bits, 32  
Error code definitions, 34 , 35  
Example logic, 25 , 28

## F

Fanuc I/O Link, 1  
Fault Active bit, 32  
Faults on I/O Link, 12

## G

Getting started, 14  
Global (%G) references used, 27  
Grounding cable, 19

## H

Hardware fault error, 34  
Hotline phone number, 34  
Humidity specification, 5

## I

I/O capacity, 1  
I/O Link Modules, number of, 3  
I/O Links, number of, 23  
I/O update, enable/disable bits, 30  
Input data, 9 , 10  
Inputs, enable/disable, bit, 30 , 31  
Installation, 15



Installation, I/O Link Module, 15  
Installation, Optical Adapter, 20  
Interrupts, 21

## L

LEDs, 4 , 15  
Link Active bit, 24 , 32  
Link Active LED, 4 , 15  
Link Cfg LED, 15  
Link control, 13  
Link Failed bit, 32  
Link failure error, 34  
Link operation stops, 12  
LINK73X, links and I/O, 23  
LINK77X, links and I/O, 23  
LINK78X, links and I/O, 23  
Logic examples, 25 , 28  
Logicmaster 90–70, 21  
Logicmaster 90–70 librarian, 24

## M

Master devices, 1  
Master/slave mode bit, 30  
Module appearance, 4  
Module installation, 15  
Module OK LED, 4 , 15  
Module removal, 16  
Module type, 5  
Monitoring the link, 32  
Monitoring the module, 32  
Multiple calls, 24

## N

Nicknames for %P references, 24 , 26  
Normal operation, 34  
Number of I/O Link Modules, 1  
Number of modules, 29

## O

Optical Adapter, 8 , 20  
Output data, 9 , 10  
Output, +5 volt, 18 , 20  
Outputs, enable/disable bit, 30

## P

Permissive logic, 30  
Pin assignments, 18  
Ports, 4  
Program Block installation, 24  
Program Blocks, 3 , 23  
Program nicknames, 26  
Program references, 26  
Programming, 23

## R

Rack location, 3 , 4 , 21 , 26 , 29  
Reference addresses, 3  
Reference assignment, 29  
References, 9  
References, maximum, 23  
Removal, 16  
Reset pushbutton, 4  
Reset/Stop link bit, 30

## S

Serial port pin assignments, 18  
Signal levels, 9  
Slave devices, 1  
Slot location, 3 , 4 , 26 , 29  
Specifications, 5  
Start Link bit, 30  
Status bit definition, 32  
Status word, 26 , 32  
Stop Link bit, 30  
System overview, 1

## **T**

Temperature specification, 5

Troubleshooting, 34

## **V**

Vibration and shock specification, 5

## Free Manuals Download Website

<http://myh66.com>

<http://usermanuals.us>

<http://www.somanuals.com>

<http://www.4manuals.cc>

<http://www.manual-lib.com>

<http://www.404manual.com>

<http://www.luxmanual.com>

<http://aubethermostatmanual.com>

Golf course search by state

<http://golfingnear.com>

Email search by domain

<http://emailbydomain.com>

Auto manuals search

<http://auto.somanuals.com>

TV manuals search

<http://tv.somanuals.com>