

# Amersham Hybridization oven/shaker

## Product User Manual

Codes: RPN2510E  
RPN2511E  
RPN2512E



# Page finder

1. Legal	3
2. Introduction	4
3. Safety warnings and precautions	5
3.1. Electrical Installation	5
4. Specification	6
5. Setting up the Hybridization Oven/Shaker	7
5.1. Setting the oven temperature	7
5.2. Setting up the rotisserie	7
5.3. Setting up the platform shaker	8
6. Hybridization using the platform shaker	9
7. Hybridization using the rotisserie	10
7.1. Assembly of membranes into bottles	10
7.2. Hybridization	10
7.3. Membrane washing procedures	11
7.3.1. Radioactive Hybridizations	11
7.3.2. AlkPhos Direct Hybridizations	11
8. Maintenance/care/cleaning of the oven/shaker	12
8.1. Error codes/faults	12
9. Troubleshooting guide	13
Appendix 1. Products for electrophoresis	14
Appendix 2. Hybond membranes for nucleic acid applications	15
Appendix 3. Radioactive labeling systems	16
Appendix 4. Non-radioactive labeling and detection systems	17
Appendix 5. Products for autoradiography and chemiluminescent detection	18
Appendix 6. Hybridization buffer	19
Appendix 7. Radiation safety products	20

# 1. Legal

GE, imagination at work and GE monogram are trademarks of General Electric Company.

Amersham, Alkphos Direct, ECF, ECL, ECL Plus, ECL Advance, Hybond, Hypercassette, Hyperfilm, Hyperscreen, Hypertorch, Megaprime, Nick, Rapid-hyb, Ready-To-Go, Rediprime, Sensitive and Trackertape are trademarks of GE Healthcare companies.

All third party trademarks are the property of their respective owners.

© 2003–2007 General Electric Company – All rights reserved.

First published November 2003

All goods and services are sold subject to the terms and conditions of sale of the company within GE Healthcare which supplies them.

A copy of these terms and conditions is available on request. Contact your local GE Healthcare representative for the most current information.

<http://www.gehealthcare.com/lifesciences>

GE Healthcare UK Limited.

Amersham Place, Little Chalfont,

Buckinghamshire, HP7 9NA UK

## 2. Introduction

One of the most widely used techniques in the molecular biology field is the immobilization of DNA and RNA onto a solid support membrane and subsequent hybridizations with a specific single stranded probe, labeled to facilitate its detection.

Using the GE Healthcare Hybridization Oven/Shaker ensures that the temperature and shaking/rotation frequency, and hence the stringency of hybridization and washing steps are rigidly controlled. This enables rapid and reproducible probing of nucleic acids, and proteins immobilized on nylon and nitrocellulose membranes.

The GE Healthcare Hybridization Oven/Shaker is a multipurpose instrument combining accurate temperature control with a choice of interchangeable hybridization modes:

- Variable speed rotisserie: holding 7 × 40 mm or 2 × 75 and 2 × 40 mm hybridization bottles.
- A variable speed platform shaker for 'box' hybridizations, depurination, denaturation and neutralization steps.

The instrument is:

- **Economical:** bottle hybridization minimizes probe volumes, reducing reagent volumes and enhancing signal intensity.
- **Precise:** stringency of hybridization and washing steps are rigidly controlled, ensuring reproducible results.
- **Sensitive:** validated protocols ensure optimal hybridization and washing steps, enhancing multiple reprobing when using Hybond™ membranes.
- **Safe:** the double-glazed polycarbonate/acrylic door offers excellent thermal insulation whilst minimizing radiation exposure.
- **Convenient:** small foot-print maximizes the use of limited laboratory space.

The instrument is suitable for use in conjunction with radiolabeled probes using Rapid-hyb™ buffer, non-radioactive nucleic acid labeling and detection systems such as AlkPhos Direct™, and protein labeling and detection systems including ECL™, ECL Plus™ and ECL Advance™. Some protocols for use with these applications are included in section 7.

# 3. Safety warnings and precautions

 If the equipment is not used in the manner described in this manual the protection provided might be impaired

This equipment is designed to operate under the following conditions: -

For indoor use only

Use in a well ventilated area

Ambient temperature range + 5°C to + 40°C

Altitude to 2000 m

Relative humidity not exceeding 80%

Mains supply fluctuation not exceeding 10%

Over-voltage category II IEC60364-4-443

Pollution degree 2

Use with a minimum distance all around of 200 mm from walls or other items

The unit should be carried using both hands.

Never move or carry the unit when in use or connected to the mains electricity supply.

In the case of mains interruption, a fault or electrical failure, the unit will continue to operate on restoration of the electricity supply or removal of the fault.

## 3.1. Electrical Installation

 **WARNING:** Lethal voltages inside the Hybridization Oven casing. Always switch the Hybridization Oven/Shaker off and remove the plug from the electrical socket before performing any cleaning or maintenance of the instrument.



**THIS INSTRUMENT MUST BE EARTHED**

**IMPORTANT:** The Hybridization Oven/Shaker has been supplied with a cordset and plug. Check that the appropriate plug for your electrical supply has been included. If there is any doubt consult a qualified electrician and inform your local GE Healthcare sales office.

Should the plug require replacement in the future, the following information should be noted:

The wires in the mains lead are coloured in accordance with the following code:

GREEN/YELLOW	Earth
BLUE	Neutral
BROWN	Live

As the colours of the wires in the mains lead of this item may not correspond with the coloured markings identifying the terminals in your plug, proceed as follows:

- The wire which is coloured green/yellow must be connected to the terminal in the plug which is marked with the letter 'E' or by the earth symbol or colours green or green/yellow.
- The wire, which is coloured blue, must be connected to the terminal, which is marked with the letter 'N' or coloured black.
- The wire, which is coloured brown, must be connected to the terminal, which is marked 'L' or coloured red.
- Fit the plug with the appropriate fuse. Always replace the plug cover, never use the plug without the cover.

The GE Healthcare Hybridization Oven/Shaker is intended for research use only and not for any other purpose.

**IF IN DOUBT CONSULT A QUALIFIED ELECTRICIAN**

# 4. Specification

---

## Overall dimensions

---

Height:	17"	(43.5 cm)
Depth:	15"	(38.0 cm)
Width:	15"	(38.0 cm)

---

## Oven dimensions

---

Height:	8"	(20.0 cm)
Depth:	9"	(23.0 cm)
Width:	10"	(25.0 cm)

---

---

**Weight:** 24 kg

---

**Capacity (nominal):** 18 litres

---

**Temperature range:** Ambient plus 5°C–80°C

---

**Temperature precision:** +/- 0.5°C

---

**Temperature fluctuation:** +/- 0.1°C (@37°C)

---

**Power rating:** 250 W

---

**Over temperature cut-out:** 1°C over set temperature

---

**Temperature variation:** < 0.25°C

---

**Rotisserie speed:** 2–10 rev/minute

---

**Shaker platform speed:** 5–70 strokes/minute

---

## Electrical

---

Nominal Voltage/Hertz/Amp	Product code
230 V / 50 Hz / 3.1 A	RPN2510E
110/120 V / 60 Hz / 4 A	RPN2511E
100 V / 50/60 Hz / 4 A	RPN2512E

---

Each instrument is supplied with 1 rotisserie (RPN2514), 6 hybridization bottles (RPN2516) and an instruction manual.

---

## Accessories

---

Rotisserie, holds 7 × 40 mm hybridization bottles	RPN2514
Rotisserie, holds 2 × 75 mm and 2 × 40 mm hybridization bottles	RPN2515
Hybridization bottle, 260 × 40 mm (For rotisserie RPN2514, pack of 6)	RPN2516
Hybridization bottle, 170 × 40 mm (For rotisserie RPN2514, pack of 6)	RPN2517
Hybridization bottle, 240 × 75 mm (For rotisserie RPN2515, pack of 2)	RPN2518
Hybridization mesh, 1 roll 21.5 cm × 10 m	RPN2519

---

# 5. Setting up the Hybridization Oven/Shaker

1. Remove all packaging and place the Hybridization Oven/Shaker on a level working surface, ensuring that there is sufficient room above the instrument to allow the door to be opened fully.
2. Leave the unit to stand for a minimum of 3 hours. This will allow acclimation to the new ambient temperature.
3. Plug the female end of the power cable into the Hybridization Oven/Shaker.
4. Connect the power cable to a suitably grounded electrical outlet. The correct operating voltage of the Hybridization Oven/Shaker is found on the product information label on the rear of the instrument.
5. Turn the Mains ON/OFF switch (1 on Fig 1) to the ON position.
6. The GE Healthcare Hybridization Oven/Shaker is now ready for use.

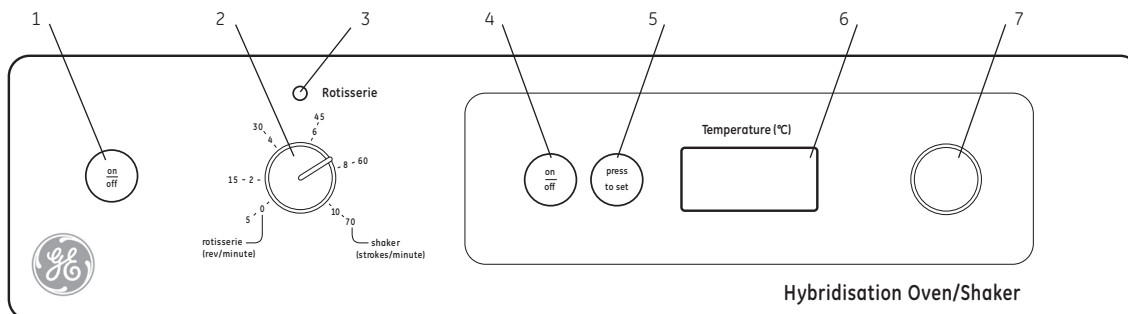

**Fig 1. Diagram of instrument control panel**

## 5.1. Setting the oven temperature

1. The Oven temperature controls are located on the right hand side of the control panel (numbers 4 to 7 in figure 1).
2. To turn the temperature control ON press the on / off button (4). The LED display (6) will show the current Oven temperature.
3. To set the temperature, press and hold the press to set button (5) and at the same time rotate the temperature selector dial (7) until the required temperature is shown on the digital display (6).
4. Release the press to set button (5) and the temperature display (6) will revert back to the actual Oven temperature.
5. The set temperature can be viewed at any time simply by pressing and holding the press to set button (6)
6. The oven will now automatically heat up to the set temperature.

### Rotisserie/shaker controls

1. Rotisserie/shaker ON/OFF button
2. Rotisserie/shaker speed selector dial
3. Motor on indicator

### Temperature controls

4. Temperature on/off button
5. Press to set button
6. LED temperature display
7. Temperature selector dial

**Note:** the Oven is fitted with automatic digital over-temperature protection (see Section 8.1. for more details).

## 5.2. Setting up the rotisserie

The rotisserie is installed in the Hybridization Oven/Shaker during transit. To use the rotisserie for bottle hybridization, the following procedure should be adopted:

1. Lift up the oven door to its fullest extent to allow complete access to the oven interior.
2. Lift the rotisserie vertically out of the oven. Unpack and place on the bench.
3. Place the membranes to be hybridized into the required number of hybridization bottles. Using the rotisserie as a stand for the bottles, place the bottles into the rotisserie, pushing them down as far as they will go.

**NOTE:** Always ensure that the weight is evenly distributed on both sides of the rotisserie. Place an empty hybridization bottle into the other side of the rotisserie as a counterbalance if necessary.

4. Place the rotisserie into the oven onto the rotation mechanism, ensuring that the serrated bands at either end of the rotisserie locate onto the steel cogs of the rotation mechanism at the rear of the oven. (B on figure 2). The plastic flanges of the rotisserie locate on to the small wheels on the oven floor. Close the oven door.
5. Ensure that the desired temperature has been set (see section 5.1).
6. The speed controls are on the left hand side of the control panel (numbers 1 to 3 in figure 1). Turn the Rotisserie/Shaker ON by pressing the on / off button (1). The red indicator light (3) above the speed selector dial (2) will illuminate.
7. Turn the Rotisserie/Shaker speed selector dial (2) clockwise until the desired rotation speed is reached (allowable values are 2–10 rpm).

The rotisserie will now start to rotate at the set speed.

8. When hybridization is complete turn the Rotisserie/Shaker OFF by pressing the on / off button (1). The red indicator (3) will go out.

### 5.3. Setting up the platform shaker

During transit, the platform is stored vertically at the rear of the oven chamber. It can remain in this position whilst the rotisserie is in use. To use the platform shaker for 'sandwich box' hybridizations, the following procedure should be adopted:

1. Open the oven door to its fullest extent, lift the rotisserie vertically and store in a safe place.
2. Lift the platform by its handle (A, see figure 2) from its storage position, slide it forward and locate it on the rocking mechanism by placing the side pegs of the platform into the retainers (D) on the side walls of the oven chamber. This action seats the nylon blocks (C) on the underside of the platform on to the pegs (E) protruding from the rocker mechanism at the rear of the oven.
3. Place the box in which the hybridization is being performed on to the shaker platform and close the oven door.
4. Ensure that the desired temperature has been set (see section 4.1).
5. Turn the Rotisserie/Shaker ON by pressing the on / off button (1). The red indicator light (3) above the speed selector dial (2) will illuminate.
6. Rotate the Rotisserie/Shaker speed selector dial (2) clockwise, until the desired shaker speed is reached. Allowable values are 5–70 strokes per minute.

The shaker platform will now oscillate at the set speed.

7. When hybridization is complete turn the Rotisserie/Shaker OFF by pressing the on / off button (1). The red indicator will go out (3).

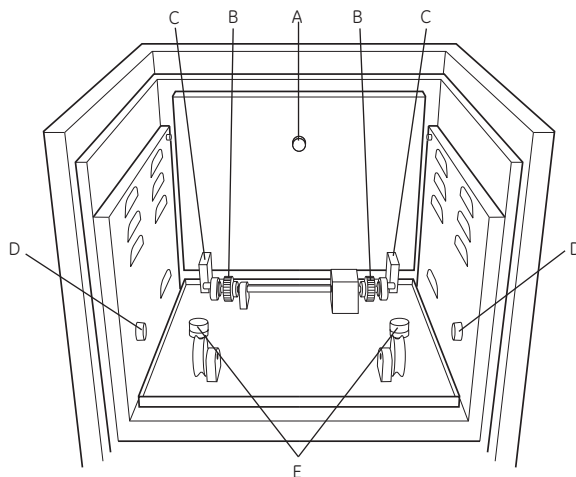

**Fig 2. Hybridization oven drive components**



# 6. Hybridization using the platform shaker

The Hybridization Oven/Shaker is compatible with the hybridization technologies available from GE Healthcare. These include radioactive hybridizations using Rapid hyb buffer and the range of non-radioactive systems for the labelling and detection of proteins and nucleic acids (see appendix 1).

When using the platform shaker the hybridization and washing conditions recommended in the appropriate GE Healthcare literature should be used. The following protocol therefore provides a guideline. For specific hybridization times and temperatures, refer to the relevant protocol booklet.

1. Prepare blots as recommended in the appropriate Hybond protocol booklet.
2. Set the oven temperature as described in section 5.1.
3. Place the membrane in a suitable box (or bag) and cover with sufficient prehybridization buffer to ensure that the entire surface of the membrane is covered. Recommended volume: surface area ratio is given in most protocol booklets. Seal the box (or bag) securely.
4. Place the box (or bag) on the platform, set the oscillation speed to 30 strokes/minute as described in section 5.3. Prehybridize for the required length of time.
5. Remove the box (or bag) from the oven and carefully add the labeled single stranded probe (denaturation may be required post labelling refer to the appropriate protocol booklet) to the prehybridization buffer.
6. Reseal the box (or bag) securely, replace it on the platform and hybridize for the required length of time.
7. Remove the membranes and place in a clean box containing the first stringency wash solution.
8. Increase the oscillation speed of the platform to 60 strokes/minute. Carry out the recommended washing protocol at the appropriate temperature and for the appropriate times.

**NOTE:** Do not pipette the probe solution directly on to the membrane as this may cause localized background.

# 7. Hybridization using the rotisserie

Several advantages are associated with performing hybridizations in bottles, namely those of safety and economy as outlined in the introduction. However, the use of bottles for hybridizations and washing procedures requires certain adaptations to standard protocols.

## 7.1. Assembly of membranes into bottles

1. Add approximately 20 ml 2 × SSC buffer into the hybridization bottle. The rotisserie acts as a convenient bottle stand.
2. Pre-wet the membrane in 2 × SSC buffer and loosely roll it up.
3. Insert the rolled up membrane into the bottle and replace the cap. Ensure that the cap is screwed on securely, (hand tight plus a quarter turn). **DO NOT OVERTIGHTEN**, or the thread of the cap can be damaged, leading to leakages.
4. Place the bottle on a flat surface and roll it gently in the opposite direction to that in which the membrane is coiled. This rolling action causes the membrane to uncoil, so lining the inner surface of the bottle.

However, studies at GE Healthcare laboratories using a wide range of hybridization mesh technologies demonstrate a resulting loss of sensitivity due to partial absorption of the probe into the mesh.

A nylon mesh (RPN2519) is available as an optional extra, as it can facilitate easier handling of a number of blots and the more fragile nitrocellulose membranes. These handling advantages should be considered against the potential loss of sensitivity before use.

When a hybridization mesh is used in conjunction with the membrane, the following procedure should be adopted:

5. Pre-wet the mesh alongside the membrane in 2 × SSC buffer and place the prewetted membrane on top of the mesh. The mesh should be slightly larger than the blot in all dimensions. Roll both up together, with the mesh on the outside of the membrane, and insert into the bottle as described above (7.1.4.).

**NOTE:** If placing several small blots into one bottle, prewet the membranes as above, and space them out along the length of the bottle with forceps.

**NOTE:** The use of a mesh in bottle hybridizations to ensure uniform contact between the membrane surface and the buffer has been recommended.

## 7.2. Hybridization

1. Set the required oven temperature as detailed in section 5.1.
2. Discard the 2 × SSC, used in the bottle to unroll the membrane, and replace with prehybridization buffer. Recommended volumes are provided in most GE Healthcare protocol booklets. Generally a minimum of 10–15 ml per 20 × 20 cm blot is advised. Seal the bottle, avoiding overtightening.
3. Place the hybridization bottle(s) into the rotisserie (as detailed in section 5.2.) add counterbalance bottles if necessary. Place the rotisserie into the oven so that the bottles are rotating in the same direction as the membrane is rolled, see Figure 3.

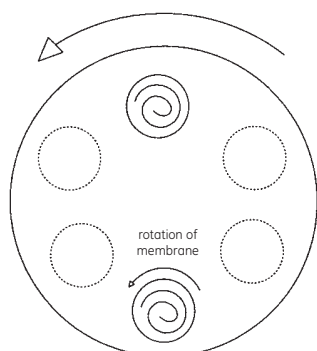

**Fig 3.** Rotation of rotisserie

4. Prehybridize the membrane for the specified length of time at a rotisserie speed of 4 rpm.
5. Following prehybridization, turn off the rotisserie, remove the rotisserie from the oven. Add the labeled probe to the buffer, either by removing an aliquot of the buffer, adding the probe and returning the aliquot to the bottle; or by adding the probe directly into the bottle, avoiding the membrane.
6. Hybridize for the specified length of time at a rotisserie speed of 4 rpm.

## 7.3. Membrane washing procedures

Membranes can either be removed from the hybridization bottles and washed in a box on the platform shaker (this is a more efficient procedure), or the washing procedure may be carried out in the bottles. If the platform shaker is used, follow the standard washing procedure mentioned in the appropriate protocol booklet.

If bottles are to be used it is necessary to modify the standard washing procedure.

Outlined in this section are the optimized washing protocols for radioactive hybridizations and non-radioactive based hybridizations.

### 7.3.1. Radioactive Hybridizations

1. Carefully drain off the hybridization buffer, rinse the bottle and the membrane thoroughly with  $2 \times$  SSC and discard.
2. Perform the following stringency washes in large volumes (100 ml minimum) of the following solutions, at a rotisserie speed of 8 rpm:
  - $2 \times$  10 minutes with  $2 \times$  SSC, 0.1% SDS at 65°C
  - $1 \times$  15 minutes with  $1 \times$  SSC, 0.1% SDS at 65°C
  - $2 \times$  10 minutes with  $0.1 \times$  SSC, 0.1% SDS at 65°C

(More washes over the same time period for each stringency condition can improve background).

3. Remove the membrane from the bottle, drain off excess stringency wash, wrap in SaranWrap™ and autoradiograph.

### 7.3.2. AlkPhos Direct Hybridizations

4. Drain off the hybridization buffer, rinse the bottle and the membrane thoroughly with primary wash buffer and discard.
5. Perform the following stringency washes in large volumes (100 ml minimum) of the following solutions, at a rotisserie speed of 8 rpm:
  - $3 \times$  10 minutes with primary wash buffer solution at 55°C
  - $3 \times$  5 minutes with secondary wash buffer at room temperature
6. Remove the membrane from the bottle and detect using the standard procedures outlined in the protocol booklet.

**NOTE:** This last step is a high stringency wash and should be omitted if related sequences are to be probed.

**NOTE:** The room temperature washes can be achieved by switching off the oven and leaving the door open whilst performing the washes or by allowing the oven to cool down to room temperature before performing the final washes.

# 8. Maintenance/care/cleaning of the oven/shaker

The GE Healthcare Hybridization Oven/Shaker is designed to provide trouble-free operation. The base of the oven and the shaker tray act as a spills tray and will contain any spillage that occurs during hybridization and washing procedures.

To ensure lasting operation the following instructions should be followed:

 **ALWAYS DISCONNECT THE HYBRIDIZATION OVEN/SHAKER FROM THE ELECTRICAL SUPPLY BEFORE CLEANING OR DRYING THE INSTRUMENT.**

1. Any leakage from the hybridization bottles or the sandwich boxes should be cleaned up immediately. Do not allow any liquids to enter the drive mechanism.
2. Wipe away any liquids from inside and outside of the unit using soap and water with a soft cloth or sponge.
3. Do not allow chemicals to remain on unit surfaces.
4. Never clean unit with abrasive pads or cleaners.
5. Never clean unit with acetone or chloroform.

 Only spare parts supplied or specified by GE Healthcare or its agent should be used. Fitting of non-approved parts may affect the performance of the safety features designed into the instrument.

## 8.1. Error codes/faults

The Oven has built in fault diagnostics. If a fault occurs, this system will display an error code in the LED display to help the service engineer rectify the problem. Please see the table below for details of error codes and other faults. In the unlikely event that a problem does occur, note down which code / fault you observe and contact your nearest GE Healthcare Office for further assistance. If you have your own service personnel available for repair, a comprehensive service manual is available on request.

<b>Fault</b>	<b>Safety system in operation</b>	<b>Fault displayed by</b>
Temperature probe PT100 reading low	Automatic over-temp system activated	LED displays Err and 0.1 alternatively
Temperature probe PT100 reading high	Automatic over-temp system activated	LED displays Err and 0.2 alternatively
Triac fault	Secondary relay control activated	Top left dot flashes in display
Rotisserie / shaker motor stalled	Cuts power to motor	No movement seen but Rotisserie red indicator light still on
Software crash	Cuts mains power	No temperature or motor motor power, all LED's blank

# 9. Troubleshooting guide

This section briefly summarizes some of the potential problems encountered during membrane hybridizations. More complete troubleshooting guides are supplied in the pack leaflet that accompany each product.

Symptom	Cause	Remedy
<b>1. Membrane curling up in hybridization bottle</b>	<b>1.1.</b> Incorrect orientation of bottle in rotisserie	<b>1.1.</b> Ensure membrane is rolled up in the same direction as the bottle is rotating (see section 7.2)
<b>2. High background</b>	<b>2.1.</b> Probe concentration too high	<b>2.1.</b> Reduce probe concentration
	<b>2.2.</b> Unincorporated <sup>32</sup> P nucleotides not removed	<b>2.2.</b> Remove unincorporated nucleotides
	<b>2.3.</b> Insufficient blocking	<b>2.3.</b> Use recommended hybridization buffer or extend prehybridization time
	<b>2.4.</b> Insufficient washing	<b>2.4.</b> Increase number of buffer changes during the washing stage or increase stringency of final wash
<b>3. Weak signal</b>	<b>3.1.</b> No transfer from gel to membrane	<b>3.1.</b> Load extra lanes with control DNA. Transfer can be checked by restaining gel with ethidium bromide. If large DNA fragments are detected poorly, use a depurination step (0.25 M HCl)
	<b>3.2.</b> Probe not labeled	<b>3.2.</b> Check probe labelling before hybridization. See protocol in probe labelling booklet
	<b>3.3.</b> Probe not denatured	<b>3.3.</b> Boil probe for 5 minutes before adding to hybridization buffer
	<b>3.4.</b> Low specific activity of probe	<b>3.4.</b> Review labelling conditions
	<b>3.5.</b> Washes too stringent	<b>3.5.</b> Increase buffer salt concentration and decrease temperature
<b>4. Patchy backgrounds</b>	<b>4.1.</b> Hybridization buffer or wash solution not evenly covering membrane	<b>4.1.</b> Increase volume of hybridization wash or solutions or use mesh (see section 7.1. step 4)
	<b>4.2.</b> Damaged membrane	<b>4.2.</b> Handle membrane carefully with forceps
<b>5. High background around edge of membrane</b>	<b>5.1.</b> Damaged membrane	<b>5.1.</b> Use clean scissors or a sharp scalpel to cut membrane

# Appendix 1. Products for electrophoresis

## DNA Markers

Precise Sizing		Digest of Natural DNAs	
50 Base-pair ladder 27-4005-01	100 Base-pair ladder 27-4007-01	KiloBase DNA marker 27-4004-01	DRigest III 27-4060-01
500 <sup>a</sup>	2000 <sup>a</sup>	10000	23130 <sup>b</sup>
450	1900	8000	9416
400	1800	6000	6557
350	1700	5000	4361 <sup>b</sup>
300	1600	4000	2322
250	1500	3000	2027
200	1400	2500	1353
150	1300	2000	1078
100	1200	1500	872
50	1100	1000	603
	1000	500	564 <sup>d</sup>
	900		310
	800		281
	700		271
	600		234
	500		194
	400		125 <sup>c</sup>
	300		118
	200		72
	100		

**a** not necessarily the largest size fragment possible, only the largest that is readily distinguishable

**b** cos ends are located on these bands

**c** may not always be visible

Marker code number	Recommended gel	Loading amount (µg/lane)	Heat before loading
27-4005-01	2% agarose/6% polyacrylamide	2.0	No
27-4007-01	1.5% agarose	2.0	No
27-4004-01	0.8% agarose	0.5	No
27-4060-01	1% agarose	0.5–1.0	60–65°C for 2 minutes

# Appendix 2. Hybond membranes for nucleic acid applications

Size	Pack size	Hybond N+	Hybond XL	Hybond N	Hybond NX	Hybond ECL	Hybond C Extra	Hybond P
82 mm	50 discs	RPN82B	RPN82S	RPN82N	RPN82T	RPN82D	RPN82E	
87 mm	50 discs	RPN87B	RPN87S	RPN87N	RPN87T			
132 mm	50 discs	RPN132B	RPN132S	RPN132N	RPN132T	RPN132D		
137 mm	50 discs	RPN137B	RPN137S	RPN137N	RPN137T		RPN137E	
82 mm	50 gridded discs	RPN1782B						
87 mm	50 gridded discs	RPN1787B						
132 mm	50 gridded discs	RPN1732B						
137 mm	50 gridded discs	RPN1737B						
30 × 50 cm	5 sheets	RPN3050B	RPN3050S	RPN3050N				
9 × 10 cm	10 sheets					RPN910D		
10 × 10 cm	10 sheets					RPN1010D		
15 × 20 cm	10 sheets	RPN1520B	RPN1520S	RPN1520N	RPN1520T	RPN1520D		
20 × 20 cm	10 sheets	RPN2020B	RPN2020S	RPN2020N	RPN2002T	RPN2020D	RPN2020E	RPN2020F
22.2 × 22.2 cm	10 sheets	RPN2222B	RPN2222S	RPN2222N				
14 × 16 cm	15 sheets							RPN1416F
12 × 10 cm	20 sheets	RPN1210B	RPN1210S	RPN1210N				
15 × 10 cm	20 sheets	RPN1510B	RPN1510S	RPN1510N				
6 × 8 cm	50 sheets					RPN68D		
7 × 8 cm	50 sheets					RPN78D		
11.9 × 7.8 cm	50 sheets	RPN119B	RPN119S	RPN119N				
22.2 × 22.2 cm	50 sheets	RPN2250B						
22.5 × 22.5 cm	50 sheets	RPN225B						
115 × 73 mm	50 sheets	RPN1576B						
20 cm × 3 m	1 roll	RPN203B	RPN203S	RPN203N		RPN203D	RPN203E	
30 cm × 3 m	1 roll	RPN303B	RPN303S	RPN303N	RPN303T	RPN303D	RPN303E	RPN303F
30 cm × 3 m	1 roll <sup>a</sup>					RPN3032D		

a = 0.2 µm pack size

# Appendix 3. Radioactive labeling systems

Labelling system	Technology	Nucleotide	Amount of template	Labelling time	Probe specific activity (dpm/ $\mu$ g)	Recommended application	Product code
<b>Rediprime™ II</b>	Random-prime	dCTP only	25 ng	10 minutes	$2 \times 10^9$	membrane hybridization	RPN1633 RPN1634
<b>Ready-To-Go™ DNA labelling beads</b>	Random-prime	dCTP only	10 ng–1 $\mu$ g	5 minutes	$2 \times 10^9$	membrane hybridization DNA labelling	27-9240-01
<b>Megaprime™</b>	Random-prime	any dNTP	25 ng	10 minutes	$2 \times 10^9$	membrane hybridization	RPN1604 RPN1605 RPN1606 RPN1607
<b>Nick translation</b>	Nick translation	any dNTP	1 $\mu$ g	2–3 hours	$2 \times 10^9$	production of large amounts of probe	N5000 N5500



# Appendix 4. Non-radioactive labeling and detection systems

Labelling and detection system	Sensitivity	Time from hybridization to detection	Duration of light output	Strip before re-probing	Quantification	Recommended application
<b>AlkPhos Direct (RPN3690)</b>	0.06 pg	1 hour	5 days	yes	no	Single copy Southern and Northern
<b>ECL Direct (RPN3000)</b>	0.5 pg	1 hour	1-2 hours	no	no	High target applications eg. colony/plaques

# Appendix 5. Products for autoradiography and chemiluminescent detection

## Hyperfilm – high performance autoradiography films

Product description	size	number sheets	code
Hyperfilm ECL	5 × 7 inches	50	28-9068-35
Hyperfilm ECL	18 × 24 cm	50	28-9068-36
Hyperfilm ECL	18 × 24 cm	100	28-9068-37
Hyperfilm ECL	8 × 10 inches	50	28-9068-38
Hyperfilm ECL	8 × 10 inches	100	28-9068-39
Hyperfilm ECL	24 × 30 cm	50	28-9068-40
Hyperfilm ECL	35 × 43 cm	50	28-9068-41
Hyperfilm MP	5 × 7 inches	50	28-9068-42
Hyperfilm MP	18 × 24 cm	50	28-9068-43
Hyperfilm MP	18 × 24 cm	100	28-9068-44
Hyperfilm MP	8 × 10 inches	50	28-9068-45
Hyperfilm MP	8 × 10 inches	100	28-9068-46
Hyperfilm MP	24 × 30 cm	50	28-9068-47
Hyperfilm MP	35 × 43 cm	50	28-9068-48
Hyperfilm MP Enveloped	18 × 24 cm	50	28-9068-50

## Hypercassette™ – cassettes for autoradiography and light detection

Size	Code (standard)	Code (deep)
18 × 24 cm	RPN11642	RPN11628
24 × 30 cm	RPN11643	
30 × 40 cm	RPN11644	RPN11627
35 × 43 cm	RPN11645	
18 × 43 cm	RPN11646	
20 × 40 cm	RPN11647	
5 × 7 inches	RPN11648	
8 × 10 inches	RPN11649	RPN11629
10 × 12 inches	RPN11650	

## Hyperscreen™ – intensifying screens for <sup>32</sup>P and <sup>125</sup>I autoradiography

Size	Code	Quantity
18 × 24 cm	RPN1662	1 pair
24 × 30 cm	RPN1663	1 pair
30 × 40 cm	RPN1664	1 pair
35 × 43 cm	RPN1665	1 pair
18 × 43 cm	RPN1666	1 pair
20 × 40 cm	RPN1667	1 pair
5 × 7 inches	RPN1668	1 pair
8 × 10 inches	RPN1669	1 pair
10 × 12 inches	RPN1670	1 pair

## Related Products

Product name	Description	Code
<b>Hypertorch™</b>	Battery powered LED darkroom torch, pack of 3	RPN1620
<b>Sensitize™</b>	Optimized preflash system	RPN2051

# Appendix 6. Hybridization buffer

Product name	Pack size	Code
<b>Rapid-Hyb buffer</b>		
Rate enhanced hybridization buffer	125 ml	RPN1635
for use with radiolabelled nucleic acid probes	500 m	RPN1636

# Appendix 7: Radiation safety products

Product Description	Product Dimensions	Quantity	Code Number
CDC storage box	240 × 140 × 130 mm	1 box	RPN2032
Pipette guards	Beta pipette guard, Gilson P20/100	1 guard	RPN1544
	Beta pipette guard, Gilson P200	1 guard	RPN1545
	Beta pipette guard, Gilson P1000	1 guard	RPN1546
	Multipack, 1 each of the above codes	3 guards	RPN1556
Beta Radiation safety starter packs		1 pack	RPN2052
Radioactive spills kit	Radioactive spills kit	1 kit	RPN2030
	Radioactive spills kit (US only)	1 kit	RPN2030US
	Refill pack for radioactive spills kit	1 pack	RPN2031
	Refill pack for radioactive spills kit (US only)	1 pack	RPN2031US
Safety screens	Beta safety screen, 15°, 530 × 355 mm	1 screen	RPN1536
	Beta safety screen, 45°, 600 × 355 mm	1 screen	RPN1537
	Beta side/rear screen, 550 × 350 mm	1 screen	RPN2034
Safety trays and liners	<b>Safety Trays</b>		
	685 × 455 mm	1 tray	RPN1534
	685 × 530 mm	1 tray	RPN2042
	530 × 330 mm	1 tray	RPN2043
	1120 × 535 mm	1 tray	RPN2063
	565 × 535 mm	1 tray	RPN2083
	455 × 255 mm	1 tray	RPN2093
	<b>Safety Tray Liners</b>		
	to match tray 685 × 455 mm	25 liners	RPN1528
	to match tray 685 × 530 mm	25 liners	RPN2048
	to match tray 530 × 330 mm	25 liners	RPN2058
	to match tray 1120 × 535 mm	25 liners	RPN2068
	to match tray 565 × 535 mm	25 liners	RPN2088
	to match tray 455 × 255 mm	25 liners	RPN2098
	Beta heavy-duty tube rack	96 × 35 × 50 mm	1 rack
Microcentrifuge tube racks	160 × 90 × 75 mm (for 1.5 ml tubes)	1 rack	RPN1542
	160 × 90 × 75 mm (for 0.5 ml tubes)	1 rack	RPN2037
Beta Waste Safes and Bags	<b>Beta Waste Safes</b>		
	400 × 240 × 220 mm	1 safe	RPN1532
	315 × 229 × 230 mm	1 safe	RPN2038
	150 × 120 × 100 mm	1 safe	RPN2039
	150 × 150 × 150 mm	1 safe	RPN2082
	<b>Waste Safe Bags</b>		
	to fit RPN1532	25 bags	RPN2091
	to fit RPN2038	25 bags	RPN2090
	to fit RPN2082	25 bags	RPN2089
	Beta Work Tank	540 × 400 × 500 mm	1 tank
Redivial workstation	160 × 90 × 75 mm	1 workstation	RPN1585
Work Boxes and Safe Storage Boxes	<b>Work Boxes</b>		
	Beta Work Box, 185 × 115 × 80 mm	1 box	RPN1539
	Beta Safe Storage Box, 300 × 185 × 155 mm	1 box	RPN1541
	<b>Work Box Inserts</b>		
	32 × 1.5 ml tubes	1 insert	RPN1540
	32 × 2.0 ml tubes	1 insert	RPN2035
	32 × 0.5 ml tubes	1 insert	RPN2036



# GE Healthcare

## **GE Healthcare offices:**

GE Healthcare Bio-Sciences AB  
Björkgatan 30, 751 84 Uppsala,  
Sweden

GE Healthcare Europe GmbH  
Munzinger Strasse 5, D-79111 Freiburg,  
Germany

GE Healthcare Bio-Sciences Corp.  
800 Centennial Avenue, P.O. Box 1327,  
Piscataway, NJ 08855-1327,  
USA

GE Healthcare Bio-Sciences KK  
Sanken Bldg. 3-25-1, Hyakunincho,  
Shinjuku-ku, Tokyo 169-0073,  
Japan

For contact information for your local office,  
please visit: [www.gelifesciences.com/contact](http://www.gelifesciences.com/contact)

GE Healthcare Limited  
Amersham Place  
Little Chalfont, Buckinghamshire,  
HP7 9NA, UK

<http://www.gehealthcare.com/lifesciences>



imagination at work

## Free Manuals Download Website

<http://myh66.com>

<http://usermanuals.us>

<http://www.somanuals.com>

<http://www.4manuals.cc>

<http://www.manual-lib.com>

<http://www.404manual.com>

<http://www.luxmanual.com>

<http://aubethermostatmanual.com>

Golf course search by state

<http://golfingnear.com>

Email search by domain

<http://emailbydomain.com>

Auto manuals search

<http://auto.somanuals.com>

TV manuals search

<http://tv.somanuals.com>