



GE Industrial Systems

INSTALLATION / USER MANUAL

Digital Energy™ LP 11U

*Uninterruptible Power Supply
5-6-8-10 kVA*



GE Digital Energy

General Electric Company
CH - 6595 Riazzino (Locarno)
Switzerland

Telephone +41 (0)91 / 850 51 51
Fax +41 (0)91 / 850 51 44
Website www.gedigitalenergy.com



LP 11U UPS

Technology for the Digital World.

ver 3.0 - US



OPERATING MANUAL Digital Energy LP 5/6/8/10-11U UPS
LX-DOC File: OPM_LPU_11U_5K0_10K_1US_V030
Manual version 3.0 Software version R2.11



INSTALLATION / USER MANUAL

Digital Energy™ LP 11U

Uninterruptible Power Supply
5-6-8-10 kVA

Preface

We thank you for selecting a **General Electric Digital Energy™ LP Series Uninterruptible Power Supply (UPS)** and recommend that you read these instructions carefully before installation and start-up of the UPS.

Please keep this manual in a safe place for future reference and carefully read the important safety instructions in chapter 1 before installation of this device.

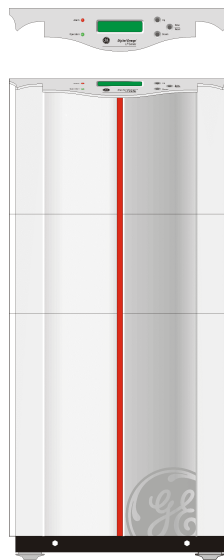

© 2003 by **GE Industrial Systems**

All rights reserved.

The information contained in this publication is intended solely for the purposes indicated.

The present publication and any other documentation supplied with the UPS system is not to be reproduced, either in part or in its entirety, without the prior written consent of GE.

The illustrations and plans describing the equipment are intended as general reference only and are not necessarily complete in every detail. The content of this publication may be subject to modification without prior notice, no liability can be accepted for any error or omission.



CONTENTS

- 1 IMPORTANT SAFETY INSTRUCTIONS..... 4
 - 1.1 Save these instructions
 - 1.2 General
 - 1.3 Installation
 - 1.4 Storage
 - 1.5 Batteries

- 2 INTRODUCTION 6
 - 2.1 Description
 - 2.2 Warranty

- 3 FUNCTIONAL EXPLANATION..... 7
 - 3.1 Principles of Operation
 - 3.2 Normal Conditions
 - 3.3 Utility Failure
 - 3.4 Automatic Bypass Switch
 - 3.5 Manual Bypass Switch

- 4 INSTALLATION..... 9
 - 4.1 Transport
 - 4.2 Unpacking
 - 4.3 Package Contents
 - 4.4 Location
 - 4.5 Installation
 - 4.5.1 Installation Procedures
 - 4.5.1.1 Standard installation procedure: Vin 208-240Vac, Vout 120/208/220/230/240Vac
 - 4.5.1.2 Installation procedure: Vin 120Vac (optional 5/6kVA), Vout 120/208/220/230/240Vac
 - 4.5.2 Available input voltages: hardware modifications
 - 4.5.2.1 Input voltage 208 or 240Vac
 - 4.5.2.2 Input voltage 120Vac (optional, 5/6kVA only)
 - 4.5.3 Available output voltages: hardware modifications
 - 4.5.3.1 Output voltage 208Vac
 - 4.5.3.2 Output volatge 120Vac split-phase
 - 4.5.3.3 Output voltage 220/230/240Vac
 - 4.5.3.4 Output voltage 120Vac single phase
 - 4.5.4 Input / output voltages: Software modification
 - 4.5.5 Installation of DE LP battery extension pack(s)
 - 4.5.6 LP-11U series: 2 / 3 / 4 parallel operating units - additional info
 - 4.5.6.1 Notes concerning installation of a parallel system
 - 4.5.6.2 Notes concerning starting up the parallel system
 - 4.5.6.3 Notes concerning use / maintenance of a parallel system

- 5 OPERATION 22
 - 5.1 Description of Front and Rear Panel
 - 5.2 Start-up
 - 5.3 Use
 - 5.3.1 Information menu
 - 5.3.2 Status and alarm menu
 - 5.3.3 Service menu
 - 5.3.4 Set-up menu
 - 5.4 Test Screens
 - 5.4.1 Battery test, general
 - 5.4.2 Quick battery test
 - 5.4.3 Deep battery test
 - 5.5 Other Features
 - 5.5.1 Shutdown
 - 5.5.2 Utility start
 - 5.5.3 Sleep and wake-up
 - 5.5.4 Overload protection in bypass mode
 - 5.5.5 ECO-Mode
 - 5.5.6 Auto restart
 - 5.5.7 Superior battery management



| | | |
|----|--|----|
| 6 | INTERFACING FEATURES | 35 |
| | 6.1 RS232/Contact Interface | |
| | 6.2 Emergency Shutdown | |
| | 6.3 Relay Card (optional) | |
| | 6.4 SNMP Interface (optional) | |
| 7 | OPTIONAL FEATURES..... | 36 |
| | 7.1 Extended Runtime | |
| | 7.2 Plug-in Cards | |
| | 7.3 RPA-Facility (Redundant Parallel Architecture) | |
| | 7.4 PDM: Power Distribution Module | |
| | 7.5 Seismic Anchors | |
| 8 | MAINTENANCE | 38 |
| | 8.1 General | |
| | 8.2 Cooling fan | |
| | 8.3 Batteries | |
| | 8.4 Safety | |
| | 8.5 Storage | |
| | 8.6 Recycling the UPS at the end of service life | |
| 9 | TROUBLESHOOTING | 39 |
| 10 | SPECIFICATIONS | 40 |
| | APPENDIX: INSTALLATION DRAWINGS | |



1 - Important Safety Instructions

1.1 Save these instructions

This manual contains important instructions that should be followed during installation and maintenance of the UPS and batteries. It also gives all necessary information about the correct use of the UPS.

Full understanding and compliance of the safety instructions and warnings contained in this manual are the **ONLY CONDITION** to avoid any dangerous situation during installation, operation and maintenance work, and to preserve the maximum reliability of the UPS system.

GE refuses any responsibility in case of non-observance, unauthorized alterations or improper use of the delivered UPS.



Before attempting to install and start up the UPS, carefully read this manual. Keep this manual next to the UPS for future references. All servicing must be done by qualified personnel. Do not attempt to service the UPS unless you have had proper training.



CAUTION: By opening or removing covers you run the risk of exposure to dangerous voltages!

While every care has been taken to ensure the completeness and accuracy of this manual, GE accepts no responsibility or liability for any loss or damage resulting from the use of the information contained in this document.

This document shall not be copied nor reproduced without the permission of GE.

Due to technical improvements, some of the information contained in this manual may be changed without notice.

1.2 General



- **CAUTION: RISK OF ELECTRIC SHOCK** Do not remove the cover, there are no user serviceable parts inside. All maintenance and service work should be performed by qualified service personnel.
- The UPS contains batteries. The output terminals may be electrically live, even when the UPS is disconnected from the utility supply. Dangerous voltages may be present during battery operation. The batteries must be disconnected during maintenance or service work.
- The UPS contains potentially hazardous voltages.

1.3 Installation

- Move the UPS in an upright position and in its original package to the final destination room.
- To lift the UPS, use a forklift or lifting belts with spreader bars.
- Check for sufficient floor and elevator loading capacity.
- Check carefully the integrity of the UPS equipment. In case you note some visible damage, do not connect any voltage to the UPS but contact the nearest Service Centre.
- This UPS is intended to be used in a controlled indoor environment and free of conductive contaminants and protected against animal intrusion.
- The UPS should only be powered from a single phase, three wire AC source equipped with an earth connection.
- In this manual "Earth" is represented with two different symbols:



= Field wiring equipment grounding terminal,



= Grounding terminals.

- Do not install the UPS in an excessively humid environment or near water.
- Avoid spilling liquids or dropping any foreign object into the UPS.
- The unit must be placed in a sufficiently ventilated area; the ambient temperature should not exceed 40°C (104°F). Optimal battery lifetime is obtained if the ambient temperature does not exceed 30°C (86°F).



- It is important that the unit has adequate ventilation. Maintain air movement around and through the unit. Do not block the air vents.
- Avoid placing the unit in direct sunlight or near heat sources.
- Do not plug household appliances such as electric heaters, toasters or vacuum cleaners into the UPS. The UPS output is intended to be used only for electronic loads such as computers and telecommunications equipment.
- Use insulated copper input and output wiring, rated 90°C (194°F) wire size based on the ampacities given in Tables 310-16 of the Nation Electrical code, ANSI/NFPA 70-1993. Specified in table 2 and table 3.

1.4 Storage

- Store the UPS with its batteries fully charged in a dry location, storage temperature must be within -20 and +45°C (-4°F and 113°F)
- If the unit is stored for an extended period of time, the batteries must be recharged periodically. Connect the unit to the mains and switch it on:
 - if the storage temperature is within -20 and +30°C (-4°F and 86°F), recharge the batteries every 6 months, for 24 hours,
 - if the storage temperature is within -20 and +45°C (-4°F and 113°F), recharge the batteries every 4 months, for 24 hours.

1.5 Batteries



- **NOTE:** Servicing of batteries should be performed or supervised by personnel knowledgeable of batteries and the required precautions. Keep unauthorized personnel away from batteries.
- When replacing the batteries, use only the same type and size battery.
Preferably for LP 5/6-11U: Kobe HV7-12 or Panasonic LC-R127R2P
LP 8/10-11U: Kobe HV12-12 or Panasonic LC-RA1212P
- **CAUTION:** A battery can present a risk of electrical shock and high short circuit current. The following precautions should be observed when working on batteries:
 - Remove watches, rings or other metal objects.
 - Use tools with insulated handles.
 - Wear rubber gloves and boots.
 - Do not lay tools or metal parts on top of batteries.
 - Disconnect charging source prior to connecting or disconnect battery terminals.
 - Determine if the battery is inadvertently grounded. If inadvertently grounded, remove source of ground. Contact with any part of a grounded battery can result in electrical shock. The likelihood of such shock will be reduced if such grounds are removed during installation and maintenance.



- Avoid charging in a sealed container.
- **CAUTION:** Never dispose of batteries in a fire: they may explode.
- **CAUTION:** Do not open or mutilate batteries: their contents may be extremely toxic. If exposed to electrolyte, wash immediately with plenty of water.
- Proper disposal or recycling of the batteries is required. Refer to your local codes for disposal requirements.



2 - Introduction

2.1 Description

More than ever before, today's advanced electronic equipment, with complex integrated circuits and other sensitive electronics, needs a stable and continuous AC power supply to operate correctly. While the power coming from the wall outlet is often unreliable, a **GE Digital Energy™ LP-U UPS** provides the security of completely uninterrupted power.

A compact, truly on-line system, the LP-U UPS protects your equipment from all forms of power interference, including complete power failure. A simple and elegant circuit design, together with extensive protection against abnormal operating conditions (e.g. overload, short circuit, overheating), makes the UPS exceptionally reliable.

The UPS offers complete galvanic isolation of input and output, also when operating in bypass mode. As a result, input and output voltages do not necessarily have to be equal, making the UPS suitable for almost every situation.

All units are standard equipped with a backfeed protection relay.

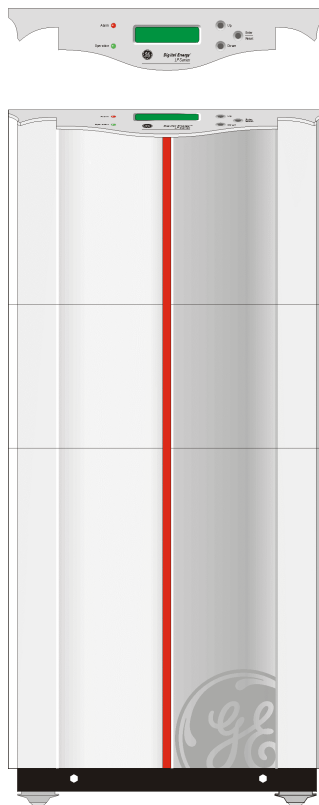

Figure 1: The GE Digital Energy™ LP 11U UPS

2.2 Warranty

GE Digital Energy, operating through its authorized agents, warrants that the standard products will be free of defects in materials and workmanship for a period of 24 months (12 months for the battery) after the date of invoice, or such other period as may be specified.



NOTE: This warranty does not cover failures of the product which result from incorrect installation, misuse, alterations by persons other than authorized agents, or abnormal operating conditions.



3 - Functional Explanation

3.1 The Principles of Operation

The UPS stores electric energy in batteries. This allows the UPS to supply output power even when the incoming utility power is cut off completely.

Energy is stored as Direct Current (DC), while input and output energy must be Alternating Current (AC). Therefore the UPS contains an input converter (AC to DC) and an output converter (DC to AC). (fig.2)

3.2 Normal Conditions

Under normal conditions, energy from the utility is channeled through the input converter, which supplies the output converter and the battery charger. The batteries are kept in a fully charged state, and the output converter synthesizes a completely new AC output sine wave to supply the load (electrical equipment).

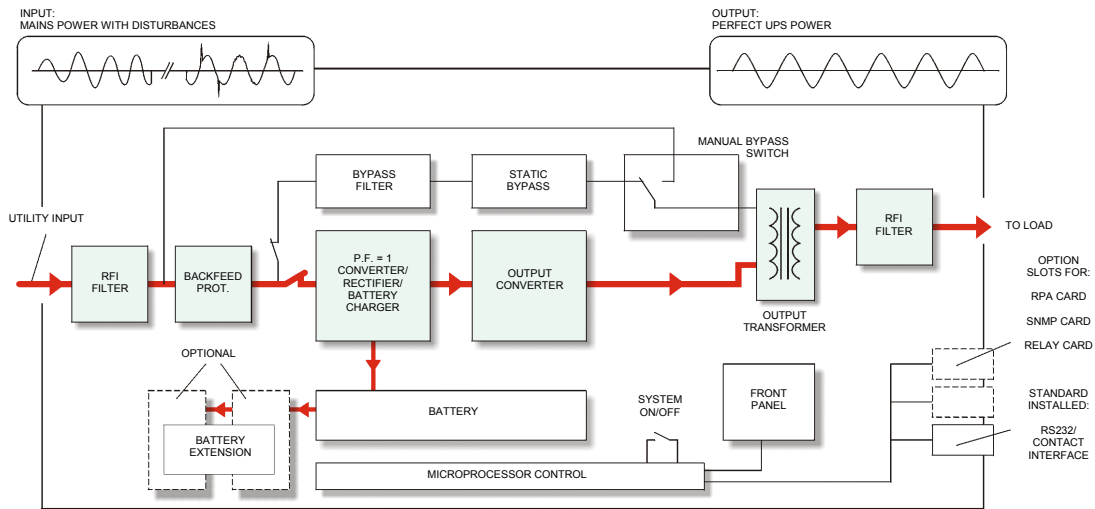

Figure 2. Block diagram of the LP 11U UPS, utility present

3.3 Utility Failure

In the event of a utility power failure (i.e. absent or outside tolerance) the system uses the energy reserve stored in the battery to continue to produce AC power, ensuring unbroken output (fig. 3). No interruption or alteration will ever be noticed in the output power.

In the event of an extended utility failure, the output converter will stop when the battery has been discharged. At this point, the UPS is no longer able to power the connected equipment.

When the utility is re-established within tolerance, the output converter will be supplied again by the input converter and the batteries will be recharged, making them ready to support future power failures.

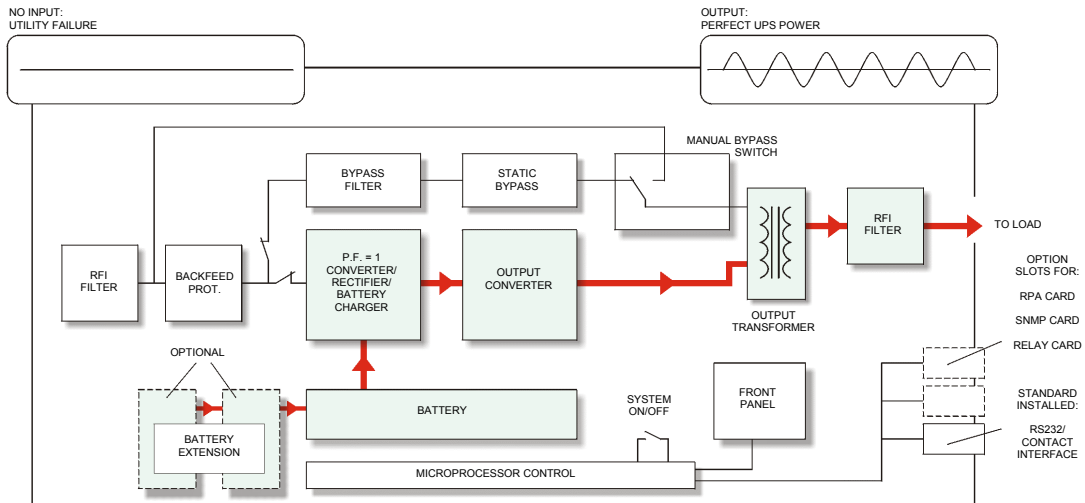

Figure 3. Block diagram of the LP 11U UPS, utility failure



3.4 Automatic Bypass Switch

If the output converter is unable to deliver the demanded output power because of overload or overtemperature, the automatic bypass switch will automatically transfer the load to the utility. When the situation is corrected the UPS will switch back to normal operation, i.e. the load is transferred back to the output converter. Though the automatic bypass switch is shown as a simple mechanical switch in figures 2-5, the transfers are done by means of thyristors, i.e. electronically, without any interruption of the power supplied to the load.

In case of a severe overload or short-circuit the magnetic bypass circuit breaker (rear panel) may trip in order to protect the UPS. If the current is insufficiently high to trip the breaker, the UPS will be switched off by the software in order to protect the UPS and connected equipment.'

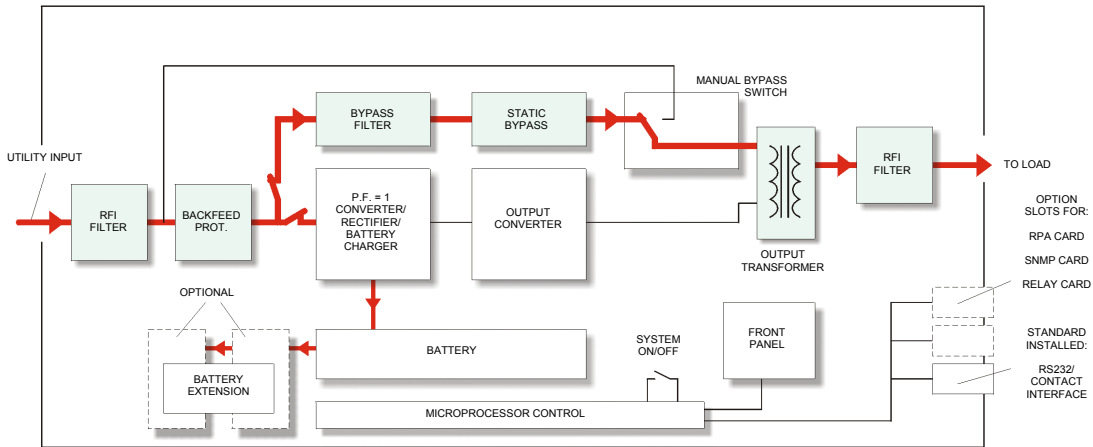

Figure 4 . Bypass operation: Automatic bypass

If a power failure occurs during bypass operation, load power may be lost. If the UPS functions under overload conditions it may not be able to protect the load.

3.5 Manual Bypass Switch (Service switch)

The system can be bypassed manually using the manual bypass switch located at the rear panel. It is a two-position switch: the normal position is '1': as in figures 2-4. Position '2' is the service position: the load is directly connected to the utility input. This way maintenance of the UPS (e.g. battery replacement, as in fig. 5) is possible without interruption of the power supplied to the load.



CAUTION: REFER SERVICE TO QUALIFIED PERSONNEL ONLY. THE RFI FILTERS AND OUTPUT TRANSFORMER ARE ALWAYS ACTIVE.

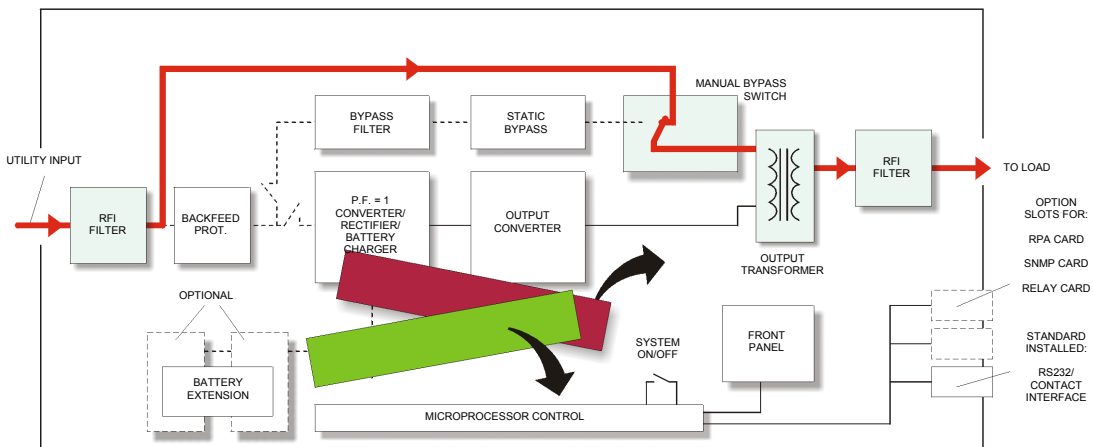

Figure 5 . Bypass operation: Manual bypass



4 - Installation

4.1 Transport



NOTE: Transport the UPS only in upright position. Check for sufficient floor and elevation loading capacity. Move the UPS in its original package to the final destination room. Do not stack other package on top.

4.2 Unpacking

Cut the two wrapping bands, and remove the shipping box. Loosen the four bolts with which the UPS is fixed to the pallet. Remove the UPS from the pallet.



BE CAREFUL! Pay attention to the **HEAVY WEIGHT** of the UPS when downloading the UPS from the pallet! **Never try to lift the unit by yourself!**

The UPS is equipped with castors, which allow easy displacement of the unit. Please take appropriate measures to avoid damage on vulnerable floors.

4.3 Package Contents

The shipping box contains a LP-U UPS, a CD-ROM, an RS232 cable, a link (5/6kVA models only, see 4.5.3) a safety guide and this manual. If the UPS is equipped with an RPA plug-in card (Redundant Parallel Architecture, right option slot at the rear of the unit) the shipping box also contains a yellow network cable and one bus terminator. Inspect the UPS for damage after unpacking. If any damage is present please notify the carrier and place of purchase immediately.

4.4 Location

Please refer to section 1.3 of 'IMPORTANT SAFETY INSTRUCTIONS'.

4.5 Installation

IMPORTANT:

Before making any connection and switching on the LP UPS, please check the following conditions:

- The voltage and frequency of your utility supply is 120/208/230/240 Vac and 50 or 60 Hz; from the factory the input and output of the UPS are set to 208 Vac / 60 Hz.
- Be sure that the UPS is wired for the present utility voltage. This is indicated on the packaging of the UPS, as well as at the I/O terminals.
- Overcurrent protection for the AC circuit is to be provided by others.



CAUTION: To reduce risk of fire, connect only to a circuit input/output provided with branch circuit overcurrent protection in accordance with the National Electrical Code, ANSI / NFPA 70, as indicated below:

| UPS model | Input overcurrent protection (Amps) | | | Output overcurrent protection (Max. Amps) | | | |
|-------------------------|-------------------------------------|------|------|---|-----------|------|------|
| | 120V | 208V | 240V | 120V (1 X) | 120V (2X) | 208V | 240V |
| Operating input voltage | | | | | | | |
| LP 5-11U | | 35 | 30 | 40 | 20 | 25 | 20 |
| LP 5-11U /120V | 60 | | | 40 | 20 | 25 | 20 |
| LP 6-11U | | 40 | 35 | 50 | 25 | 30 | 25 |
| LP 6-11U /120V | 70 | | | 50 | 25 | 30 | 25 |
| LP 8-11U | | 60 | 45 | 70 | 35 | 40 | 35 |
| LP 10-11U | | 70 | 60 | 80 | 40 | 50 | 40 |

Table 1. external input fuse value



- Ensure that the total power requirement of the equipment to be protected does not exceed the rated output power of the UPS. (output power for your unit is indicated on the rating label on the rear panel).
- When using the 120V split phase outputs make sure that the load per 120V output does not exceed half the rating.
- The UPS may only be installed by trained personnel. The UPS must be grounded when in use: Connect the UPS to a single phase, three wire AC source equipped with an earth connection.
- Use insulated copper input and output wiring, rated 90°C derated to 40°C, wire size based on the ampacities given in Tables 310-16 of the National Electrical code, ANSI/NFPA 70-1993.

This wiring shall have the following minimum sizes:

INPUT WIRING:

| UPS model | Utility voltage | | |
|-----------|-----------------|--------|--------|
| | 120V | 208V | 240V |
| LP 5-11U | 6 AWG | 10 AWG | 10 AWG |
| LP 6-11U | 4 AWG | 8 AWG | 10 AWG |
| LP 8-11U | N/A | 6 AWG | 8 AWG |
| LP 10-11U | N/A | 4 AWG | 6 AWG |

Table 2. Input wiring

OUTPUT WIRING:

| UPS model | Output voltage | | |
|-----------|----------------|--------|--------|
| | 120V | 208V | 240V |
| LP 5-11U | 8 AWG | 10 AWG | 10 AWG |
| LP 6-11U | 8 AWG | 10 AWG | 10 AWG |
| LP 8-11U | 6 AWG | 8 AWG | 8 AWG |
| LP 10-11U | 4 AWG | 8 AWG | 8 AWG |

Table 3. Output wiring

TIGHTENING TORQUE FORCE:

| UPS model | Tightening torque force |
|------------------|-------------------------|
| LP 5/6-11U/120V | 22 Lbs/inch |
| All other models | 18-20 Lbs/inch |

Table 4. Tightening torque force



4.5.1 Installation Procedures

4.5.1.1 Standard installation procedure: input voltage 208-240Vac, output voltage 120/208/220/230/240Vac.

If a battery extension pack is to be installed, please proceed with section 4.5.5.
If 2, 3 or 4 parallel operating units will be installed, please proceed with section 4.5.6.
The numbers between (brackets) refer to figure 19 in section 5.1.

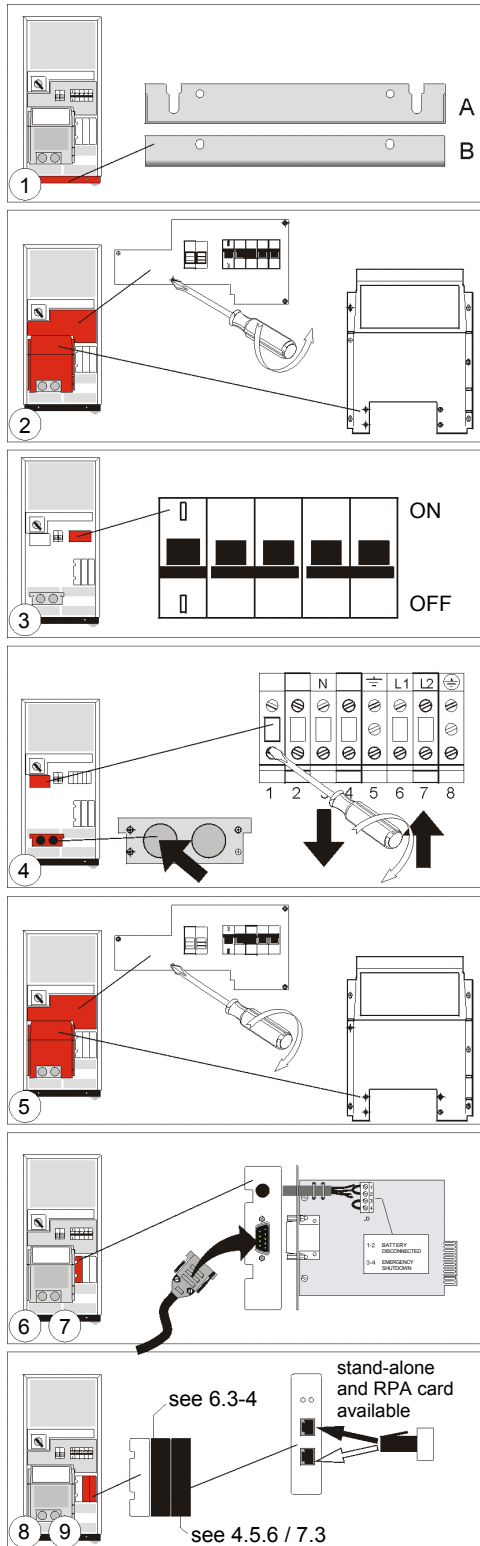

Figure 6. LP 5/68/10-11U:
Standard installation procedure

1. Mount the levellers: position A to fix the UPS to the floor, position B to lift the castors from the floor.
2. Loosen the screws and remove the conduit box (17) and the metal cover plate (11).
3. Make sure that all circuit breakers (7-8-9) are in 'off' position (down).
4. Input/output connection:
Lead the input/output cables through the cable inlet. If the cables come from below (recommended for 8kVA and 10kVA models), you can rotate the cable inlet 90 degrees. Connect the input/output wires to the I/O terminals (11a and 11b). Please refer to section 4.5.2 1 (input) and 4.5.3 (output) for detailed information.
5. Re-install the metal cover plate (11) and the conduit box (17).
6. An emergency shutdown switch can be connected to connector J3 on the RS232/Contact Interface Card, between pins 3 and 4. See section 6.2 for more information.
7. For advanced communication possibilities, the RS232/contact interface port (12a) can be connected to a computer system. See section 6.1 for more information.
8. The middle 'option slot' (13) allows easy installation of plug-in cards: SNMP Card or Relay Card. See sections 6.3 and 6.4 for more information.
9. The right 'option slot' (14) allows easy installation of the RPA-card (Redundant Parallel Architecture). If the card is already mounted, and if the unit is intended to be used stand-alone, a bus terminator (delivered with the unit) has to be placed in one of the two bus connectors on the card. If the unit will be part of a parallel system, see sections 4.5.6 and 7.3 for more information.
10. Connect the utility power to the UPS.
11. If hardware modifications were necessary in step 4 because the I/O voltages are different from the default (208Vac), software modifications should be performed as well. Proceed with 4.5.4.
12. For a quick start proceed with section 5.2 'Start-up'.



4.5.1.2 Installation procedure:
input voltage 120Vac (optional, 5-6kVA only), output voltage 120/208/220/230/240Vac.

If a battery extension pack is to be installed, please proceed with section 4.5.5.

If 2, 3 or 4 parallel operating units will be installed, please proceed with section 4.5.6.

The numbers between (brackets) refer to figure 19 and 20 in section 5.1.

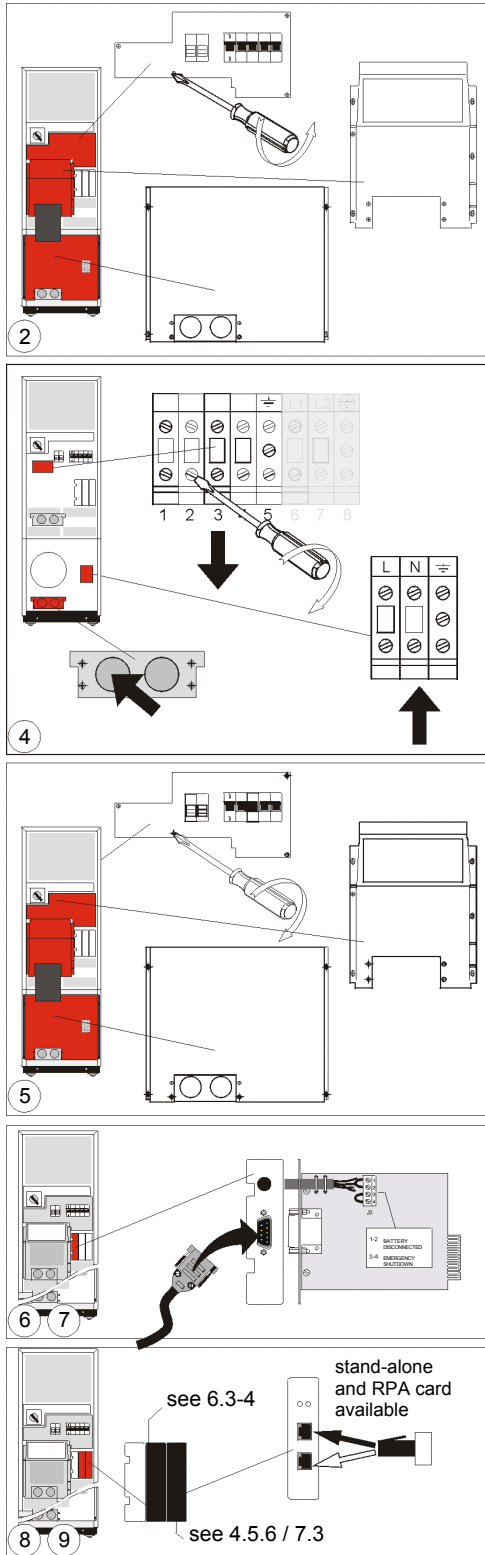

Figure 7. LP 5/6-11U:
Installation procedure 120V input

1. Mount the levellers: position A to fix the UPS to the floor, position B to lift the castors from the floor. Please refer to figure 6, step 1.
2. Loosen the screws and remove the conduit boxes (17, 2x) and the cover plate (11).
3. Make sure that all circuit breakers (7-8-9) are in 'off' position (down). Please refer to fig. 6, step 3.
4. Input/output connection:
Lead the input/output cables through the cable inlet. If the cables come from below (recommended for 8kVA and 10kVA models), you can rotate the cable inlet 90 degrees. Connect the input wires to the input terminals (11b). Connect the output wires to the output terminals (11a). Please refer to section 4.5.2.2 (input) and 4.5.3 (output) for detailed information.
5. Re-install the cover plate (11) and the conduit boxes (17, 2x).
6. An emergency shutdown switch can be connected to connector J3 on the RS232/Contact Interface Card, between pins 3 and 4. See section 6.2 for more information.
7. For advanced communication possibilities, the RS232/contact interface port (12a) can be connected to a computer system. See section 6.1 for more information.
8. The middle 'option slot' (13) allows easy installation of plug-in cards: SNMP Card or Relay Card. See sections 6.3 and 6.4 for more information.
9. The right 'option slot' (14) allows easy installation of the RPA-card (Redundant Parallel Architecture). If the card is already mounted, and if the unit is intended to be used stand-alone, a bus terminator (delivered with the unit) has to be placed in one of the two bus connectors on the card. If the unit will be part of a parallel system, see sections 4.5.6 and 7.3 for more information.
10. Connect the utility power to the UPS.
11. If hardware modifications were necessary in step 4 because the output voltage is different from the default (208Vac), software modifications should be performed as well. Proceed with 4.5.4.
12. For a quick start proceed with section 5.2 'Start-up'.



4.5.2 Available input voltages: hardware modifications

The following input voltages are possible: 208, 240 Vac (see 4.5.2.1) and 120 Vac (see 4.5.2.2)

4.5.2.1 Input voltage 208 or 240Vac.

1. Input voltage is 208 Vac. This is the factory setting. Proceed with step 3.
2. Input voltage is 240Vac. In this case the bypass tap on the output transformer must be changed. Please refer to fig. 8 and 8a. Proceed as follows:
 - 2.1 Remove the yellow wire B from faston 74 (connect) and place this wire on faston 72 (park).
 - 2.2 Remove the blue wire A from faston 61 (park) and place this wire on faston 74 (connect).

Bypass tap factory setting: 208 Volt

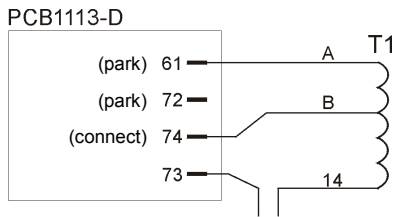

Bypass tap changed to 240 Volt

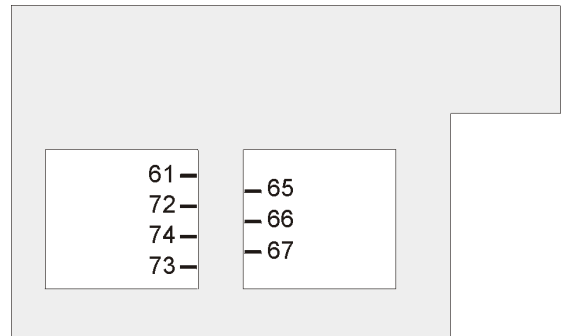
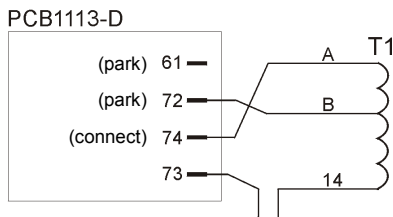

Figure 8. LP 5/6/8/10-11U:
Bypass tap change

Figure 8a. LP 5/6/8/10-11U:
Rear view

3. Connect the utility supply wires to terminals 6 (L1), 7 (L2) and 8 (equipment grounding conductor). See figure 9. Ground connection is essential!
If a neutral wire is part of the site wiring provided, we suggest to isolate this wire for future use or other applications.

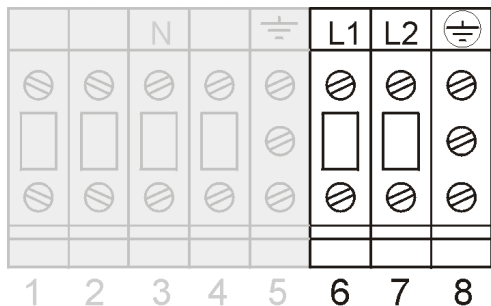

Figure 9. LP 5/6/8/10-11U:
Output (grey) / input terminals

4. For the output voltage proceed with 4.5.3.



4.5.2.2 Input voltage 120Vac (optional, 5/6kVA only).

LP-U UPS equipped with an (optional) step-up transformer (5/6kVA models only) can be connected to an input voltage of 120Vac.

1. Connect the utility supply wires to terminals L, N and GND (equipment grounding conductor). See figure 10. Ground connection is essential!

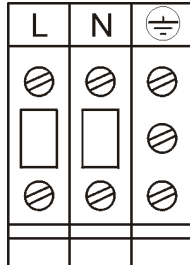

Figure 10. LP 5/6-11U:
120Vac Input terminals

2. For the output voltage proceed with 4.5.3.

4.5.3 Available output voltages: hardware modifications

The off-factory setting is 208 Vac: a link is placed between terminals 2 and 3. An extra link was delivered with the unit (in a plastic bag) to enable other output voltages (5/6kVA models only). The following voltages are available: 120, 208, 220, 230, 240 Vac.

4.5.3.1 Output voltage 208Vac

This is the off-factory setting. There is a link between terminal 2 and 3.

1. Connect the output wires to the terminals 1 (L1) and 4 (L2).
2. Connect the ground wire to terminal 5. Ground connection is essential! See figure 11.

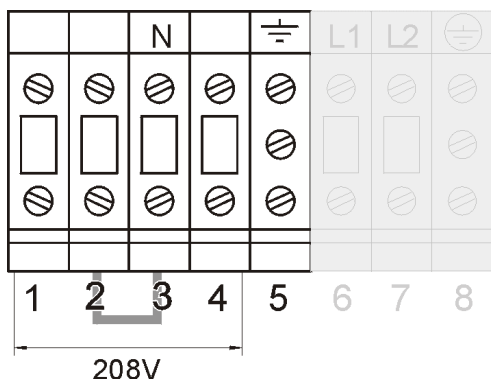

Figure 11. LP 5/6/8/10-11U:
208 Vac output connection

3. Return to either 4.5.1.1 step 5 or 4.5.1.2 step 5



4.5.3.2 Output voltage 120Vac split-phase

1. The factory setting of the output tap (208Vac) has to be changed to 240Vac. Please refer to fig. 12 and 12a. Proceed as follows:
 - 1.1 Remove the yellow wire L from faston 67 (connect) and place this wire on faston 65 (park).
 - 1.2 Remove the brown wire F from faston 66 (park) and place this wire on faston 67 (connect).

Output tap factory setting: 208 Volt

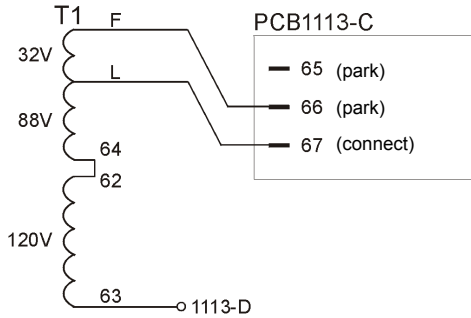

Output tap changed to 240 Volt

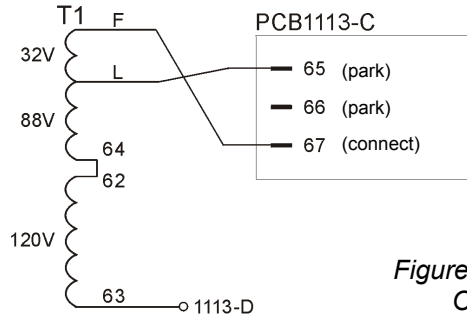

Figure 12. LP 5/6/8/10-11U: Output tap change

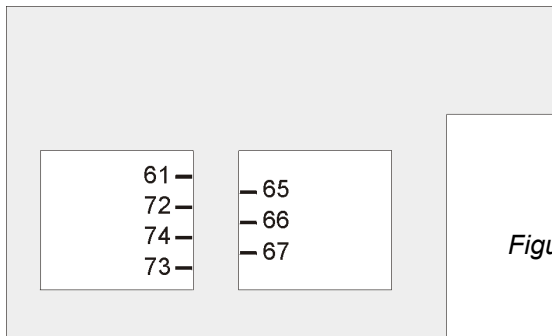

Figure 12a. LP 5/6/8/10-11U: Rear view

2. Connect the load wires between the terminals 1 (L1) and 2 (N) (120V), and between the terminals 3 (N) and 4 (L2) (120V). Connect the ground wire to terminal 5. Ground connection is essential! Do not remove the link between terminals 2 and 3. See figure 13.

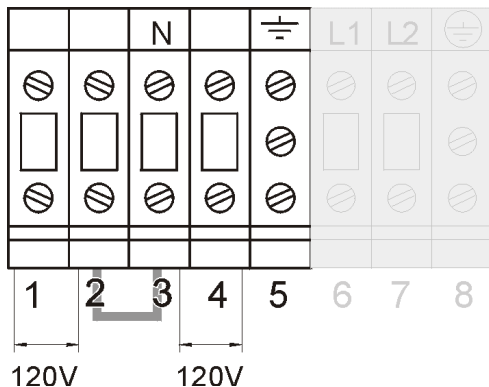

Figure 13. LP 5/6/8/10-11U: 120 Vac split-phase output connection

3. Return to either 4.5.1.1 step 5 or 4.5.1.2 step 5



4.5.3.3 Output voltage 220/230/240Vac

1. The factory setting of the output tap (208Vac) has to be changed to 240Vac. Follow the procedure as described in section 4.5.3.2 steps 1.1 and 1.2.
2. Connect the load wires between the terminals 1 (L1) and 4 (N). Connect the ground wire to terminal 5. Ground connection is essential! Do not remove the link between terminals 2 and 3. See figure 14.

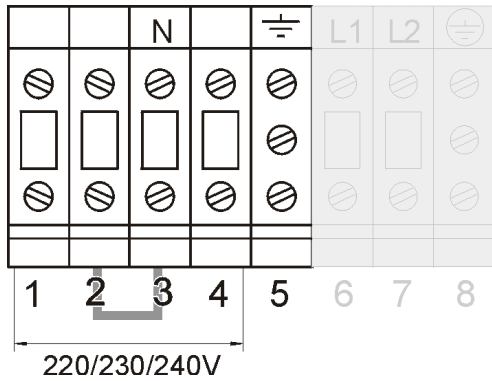

Figure 14. LP 5/6/8/10-11U:
220/230/240 Vac output connection

3. Return to either 4.5.1.1 step 5 or 4.5.1.2 step 5

4.5.3.4 Output voltage 120Vac single phase

1. The factory setting of the output tap (208Vac) has to be changed to 240Vac. Follow the procedure as described in section 4.5.3.2 steps 1.1 and 1.2.
2. Remove the link between terminals 2 and 3.
3. Place this link between terminal 1 and 2.
4. Place the extra link (delivered with the unit) between terminals 3 and 4.
5. Connect the load wires between connectors 1 (or 2) and 3 (or 4).
For LP 8/10kVA: If the wire size does not allow to place two wires (i.e. load wire and link) in one terminal, proceed with step 8.
6. Connect the ground wire to terminal 5. Ground connection is essential!
7. Return to either 4.5.1.1 step 5 or 4.5.1.2 step 5.

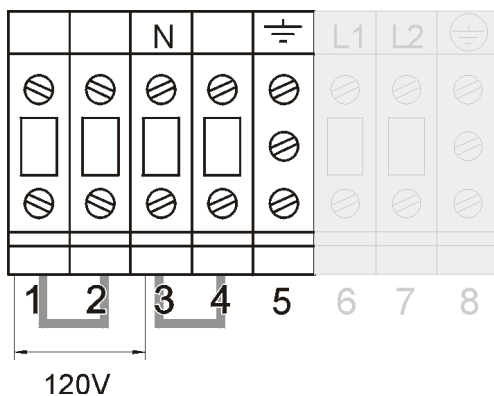

Figure 15. LP 5/6-11U:
120 Vac single phase output connection



For LP 8/10kVA:

8. Remove all links between the terminals.
9. Split both the load wires and spread one wire over terminal 1-2 and the other over 3-4 respectively.
10. Connect the ground wire to terminal 5. Ground connection is essential! See figure 15a.
11. Return to either 4.5.1.1 step 5 or 4.5.1.2 step 5

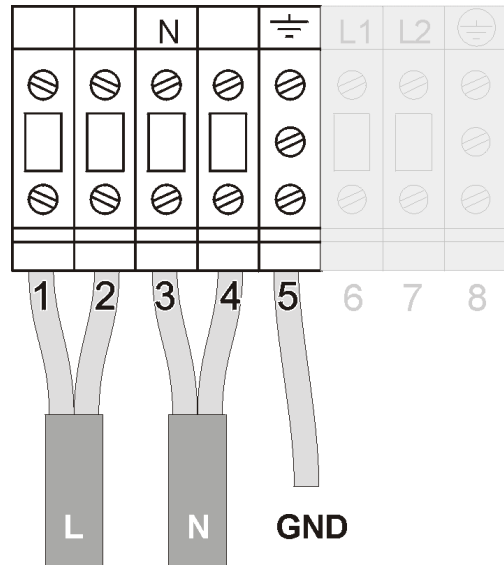

Figure 15a. Output cable splitting for 8/10kVA 120V 2-wire

4.5.4 Input/output voltages: Software modification.

NOTE: following this procedure you realize that the values shown in the LCD match the actual input/output voltages.

1. Switch on the circuit breakers 'utility' (8) and 'bypass' (9) (see also section 5.2, step 1-2)
2. Go to the set-up menu. See 5.3.4 'Set-up Menu'



3. Using the push-buttons 'up' and 'down' you can scroll through the several set-up screens. 'Enter/Reset' confirms the screen choice. Go to the set-up screen 'INPUT VOLTAGE'.

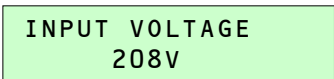

4. Here you can change the input voltage to 240 Volt. The value of the input voltage blinks. Scroll through its settings by using the push-buttons 'up' and 'down', the new setting is confirmed by pressing 'Enter/Reset'.

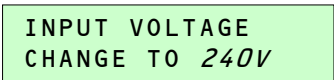

5. Go to the set-up screen 'OUTPUT VOLTAGE'.

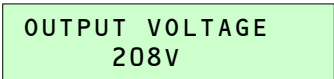

6. Here you can change the output voltage to 240 Volt. The value of the input voltage blinks. Scroll through its settings by using the push-buttons 'up' and 'down', the new setting is confirmed by pressing 'Enter/Reset'.

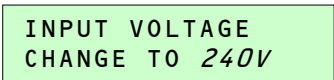

7. To return to the default screen scroll to the set-up screens first and press 'Enter/Reset'. You can also wait 20 seconds: the time-out period of no key activity.
8. You can now proceed with 5.1 or 5.2.



4.5.5 Installation of GE Digital Energy™ LP-U battery extension pack(s)

The numbers between (brackets) refer to figures 19-21 in section 5.1.

Battery extension pack(s) are shipped with all materials necessary to connect them to the UPS. The pack(s) can be connected to the DC connector (15) at the rear panel of the UPS. Be sure to switch off the UPS before proceeding: be sure that the UPS can be switched off without causing damage to the load, and turn all circuit breakers (7-8-9) into 'off' position (down).

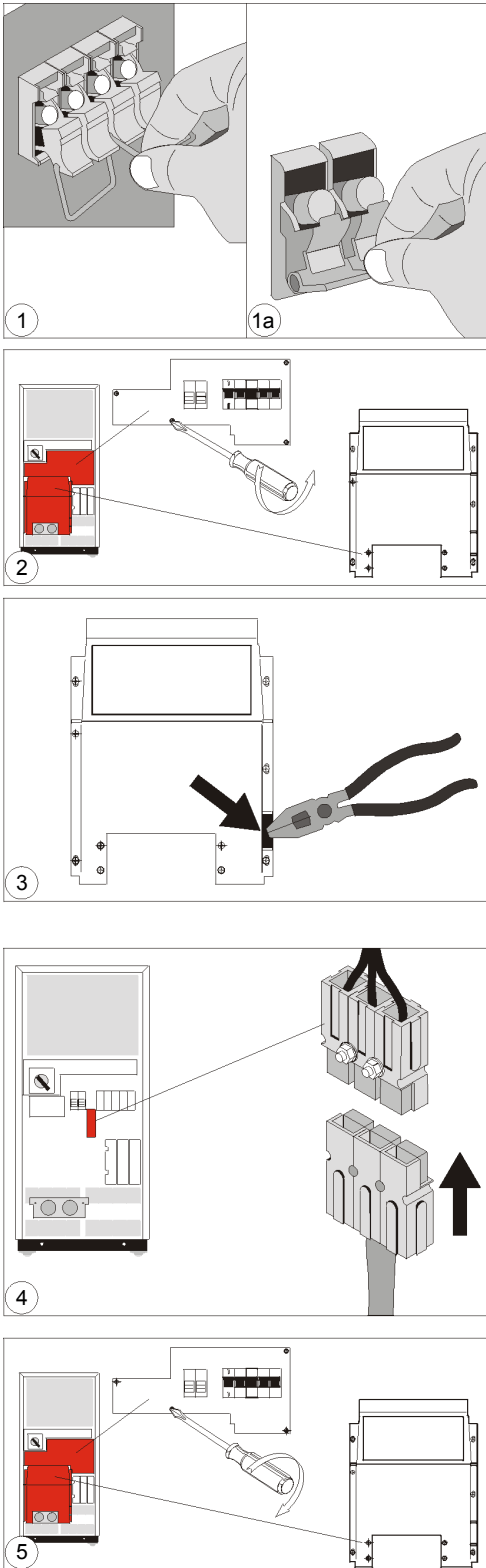

Figure 16. LP 5/6/8/10-11U:
Installation of battery pack

1. Open the DC fuse holders at the rear of the battery pack (16) and make sure that the fuses have been removed.
- 1a. Open the DC fuse holders at the rear of the UPS (16) and make sure that the fuses have been removed.
2. UPS rear panel: loosen the screws, and remove the cover plate (11) and conduit box (17).



CAUTION! The battery voltage is 240Vdc and is NOT isolated from the utility.

3. Break out the indicated part of the conduit box, fix the gland of the DC cable in this opening.
4. Connect the DC connector of the battery pack (15a) to the DC socket of the UPS (15). Be sure that the colours match. You will hear a click when the cable is properly installed.
5. Re-install the cover plate and conduit box.
6. In case of 14Ah battery packs: using the DC connector of the battery pack (15) you can install a second, third, etc. pack. 7Ah battery packs cannot be connected in parallel.

NOTE: A maximum of two Digital Energy™ 14Ah battery cabinets can be connected without additional fusing. Every two additional Digital Energy™ 14Ah battery cabinets must be connected over a 60Amp fuse, rated for 300Vdc.

NOTE: Third party battery cabinets must be connected over a 60Amp fuse, rated for 300Vdc, using the Digital Energy™ external battery cable (order separately).

7. Insert the 2 (7Ah) or 4 (14Ah) DC fuses of the (each) battery pack, insert the DC fuses of the UPS and close the fuse holder(s) of battery pack and UPS (16).
8. In order to calculate the available back-up time related to the actual load, information on the capacity of the battery set is stored in the UPS. As the total battery capacity changes when battery extension packs are installed, the battery capacity must be re-programmed. See 5.3.4.

In case of a custom-built battery extension set you may want to install a 'battery disconnected' alarm device.

9. Be sure that the UPS is switched off, and disassemble the RS232/Contact Interface Card (12) from the unit. *If the card is disassembled during normal operation the UPS will shut down!* Remove the wire from connector J3 (pin 1 and 2). Install the wiring of a normally closed contact (e.g. an auxiliary contact of a circuit breaker) to pin 1 and 2. Re-install the interface card. If the contact is opened, the UPS will generate an 'EXTERNAL BATTERY FUSE FAILURE'. See 5.3.2 for more information.

Proceed with 4.5.1 or 5.2.



4.5.6 LP 11U series: 2 / 3 / 4 parallel operating units – additional info

The RPA option (Redundant Parallel Architecture) allows you to create a redundant UPS system in which 2, 3 or 4 LP-U units operate in parallel. The following should be considered when installing units in parallel.

This section gives additional information on:

- installation (4.5.6.1)
- start-up (4.5.6.2)
- use / maintenance (4.5.6.3)

4.5.6.1 Notes concerning installation of a parallel system

1. All inputs of the UPSs must be supplied from the same phase. This is to enable bypass operation of the parallel system. All inputs must be individually protected by fuses in the installation. The values of these fuses should correspond to the values mentioned in section 4.5 table 1.
2. All outputs must be connected together, supplying the load. It is advised to install switches (S 1-4, fig. 17) in the output wiring, in order to be able to isolate a unit from the remaining system for service and maintenance purposes. It is advised to make a Neutral-to-Ground bounding in the output junction.
3. The diameter of input and output cables must be according to the table in the installation drawings (see appendix). Cables with different diameters can cause tripping fuses in the UPS and/or the installation.
4. The length of all input cables from the input junction (Li, fig. 17) to the UPS inputs should be equal. The same applies to the cables from the outputs to the output junction (Lo, fig. 17). The minimum length of the input as well as the output cables is 3 meters / 10 feet.

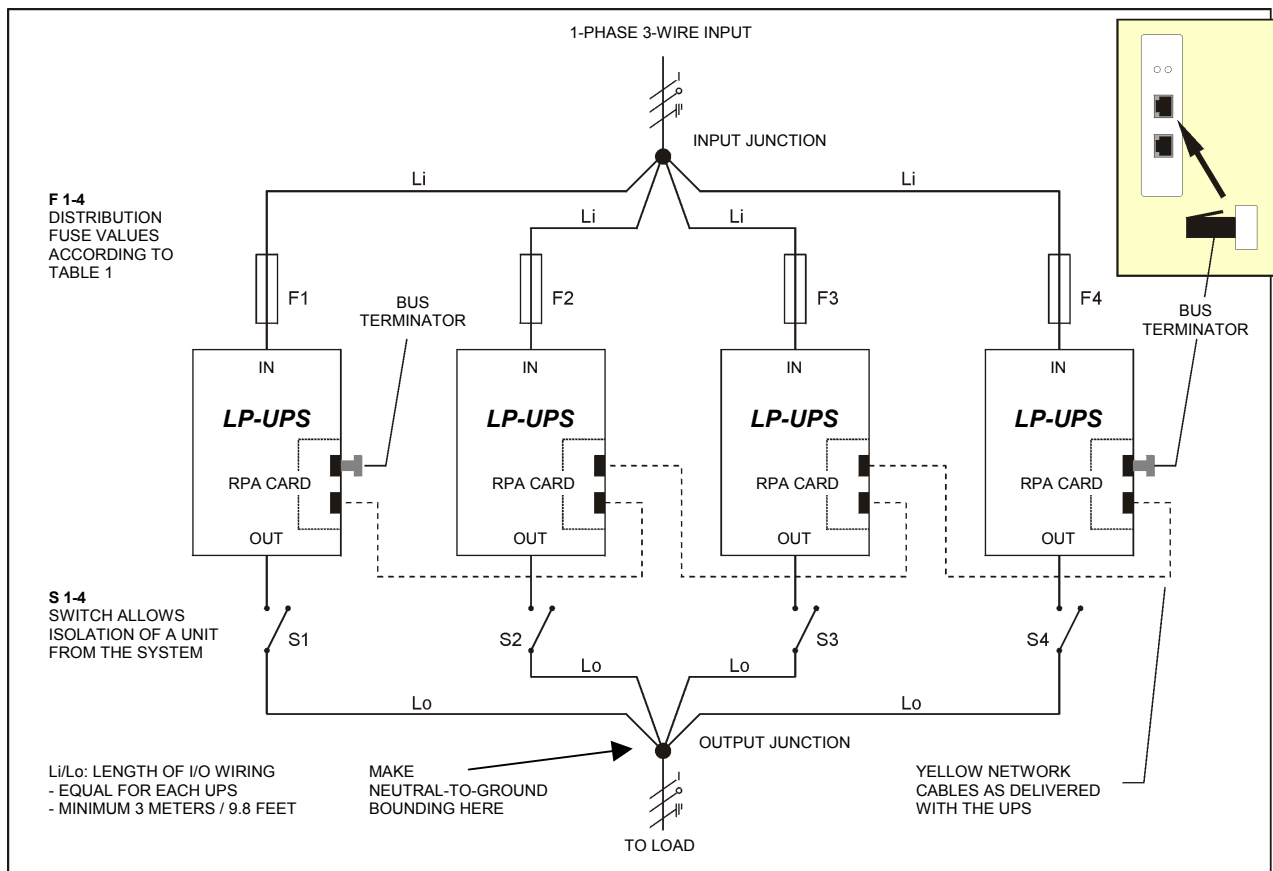

Figure 17. Installation of parallel operating LP-U UPSs



- The right option slot (14) at the rear of the unit contains the the RPA-card. Before the parallel system can be put into operation a unique number has to be appointed to each UPS in the system. This can be 0, 1, 2 or 3. Start with 0 for the first unit, 1 for the second, 2 for the third and 3 for the last unit:
 - loosen the screws, remove the RPA-card
 - set the dipswitch to the appointed number (fig. 18)
 - re-install the RPA-card, fasten the screws.

Do NOT install the network cables between the RPA-cards of the units yet!

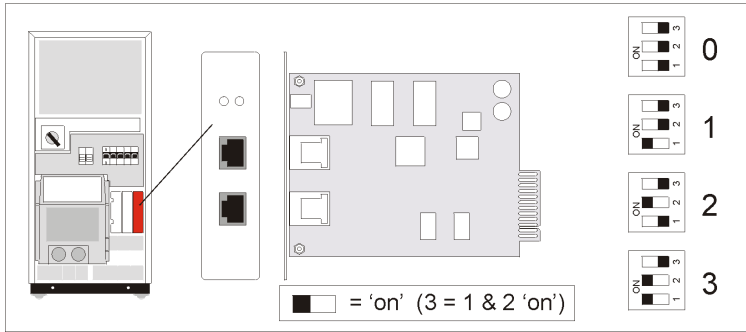

Figure 18. Appointing a unique number to each UPS in the system

- In the UPS many parameters can be set. It is advised to keep the same setting for each parameter in each UPS in the parallel system. In any case the following parameters are critical and should have equal settings:
 - autorestart (on/off, see 5.3.3)
 - output voltage (120/208/220/230/240 Vac, see 5.3.4)
 - output frequency (50/60 Hz, see 5.3.4)

It is absolutely required that these parameters are set to the same value. Off factory this is the case. If you're not sure that the units have equal settings:

- be sure that the RPA-cards of the units have not been interconnected yet
- be sure that utility power is connected to the UPS
- start each unit individually (see 5.2), check / change the parameters, and switch the unit off again.

- Interconnect the RPA-cards of the units, using the network cable that came with the UPS. See figure 17 (dotted line). Only install the cables that were delivered with the UPSs! Of the first and the last UPS in the system only one RPA-socket is used to interconnect the UPSs. A bus terminator must be placed in the other (free) RPA-socket. The required bus terminators have been delivered with the unit.

4.5.6.2 Notes concerning starting up the parallel system

For starting up the system please refer to section 5.2.

After switching on all units the LP UPSs will show the following display:

```

AUTORESTART OFF
PRESS ENTER
  
```

After pressing the 'Enter/Reset' button on one of the units the system will start up. All units will display the standard screen. The number in the lower right corner indicates the number of the UPS in the system.

```

LP 5-11U
LOAD 40%      2
  
```

If the parameters mentioned in 4.5.6.1 step 6 are not set to the same value the UPS will display the following screen after start-up:

```

AUTORESTART OFF
SETTING MISMATCH
  
```

In this case check and correct the setting of the parameters as mentioned in 4.5.6.1, step 6.



4.5.6.3 Notes concerning use / maintenance of a parallel system

ECO-mode:

If LP-U units operate in parallel, the ECO-mode feature is not available.

No-load shutdown:

If LP-U units operate in parallel, the no-load shutdown function is not available.

Manual bypass:



If you want to switch one of the UPSs to bypass operation using the manual bypass switch (switch is turned into position 2) then all UPSs in the parallel system have to be switched to bypass operation in order to prevent damage.

Maintenance:

To isolate a unit from the redundant system:

1. Switch off the UPS which has to be isolated,
2. Remove the installation fuse from the input of that UPS (F1-4 in figure 17),
3. Separate the output of the UPS from the output junction (S1-4 in figure 17).

To re-enter the unit into the system:

4. Reinstall the installation input fuse,
5. Connect the output of the UPS to the output junction,
6. Switch on the UPS.



5 - Operation

5.1 Description of Front and Rear Panel

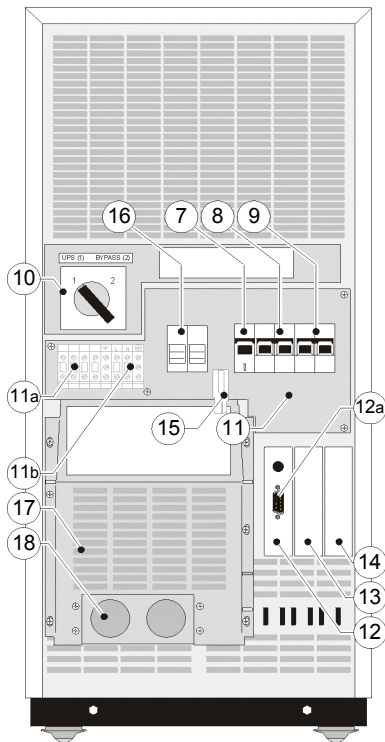
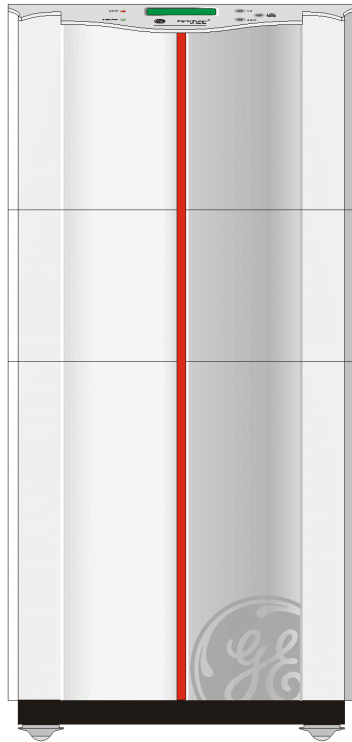
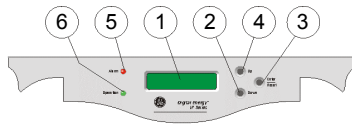

- 1 LCD screen
2x16 characters, shows UPS system data, status messages, settings.
The language is selectable: English, German, French, Italian, Spanish. Section 5.3.4 describes the selection procedure.
 - 2-4 Push-buttons
With the button keypads 'Down' (2) and 'Up' (4) you can scroll through the several screens, with keypad 'Enter/Reset' (3) a selection is confirmed. Keypad activity is accompanied by a short beep. If there is no keypad activity during 20 seconds the LCD screen will return to the default screen (except for the service screens, see section 5.3.3).
 - 5 LED 'operation' indicates normal operation.
 - 6 LED 'alarm', indicates an alarm situation, accompanied by alarm message(s) on the display and a sounding buzzer.
See section 5.3.2 for more information.
 - 7 Switch 'UPS on/off', turns on/off the complete UPS, including the automatic bypass!
 - 8 Circuit breaker 'Utility on/off', protection fuse for utility input and battery charger.
 - 9 Circuit breaker 'Bypass on/off', fuse to protect the system in case of severe overload or short circuit in the UPS load.
 - 10 Manual Bypass Switch:
 - 1 = Load on UPS
 - 2 = Load on utility
-  **WARNING:** In position 2, if the input line is energized, the output is also live regardless the position of the circuit breakers 'utility' and 'bypass'.
- 11 Cover plate, behind it:
 - 11a Output terminals
 - 11b Input terminals
 - 12 RS232/Contact Interface Card, with:
 - 12a - RS232 Interface Port (see section 6.1)
 - Emergency shutdown (see 4.5.1 and 6.2)
 - Battery disconnected, pin 1-2 (can be used for external signaling).
 - 13 Free option slot for plug-in cards:
 - Relay Card (see 6.3)
 - SNMP Card (see 6.4)
 - 14 Option slot for RPA (Redundant Parallel Architecture) Card. Not available yet.
 - 15 DC socket / connector.
 - 16 Battery fuse holder
 - 17 Conduit box
 - 18 Cable inlet

Figure 19 :
Front and rear panel



Rear panel of the step-up transformer:

- 11b Input terminals L, N and GND
- 17 Conduit box
- 18 Cable inlet

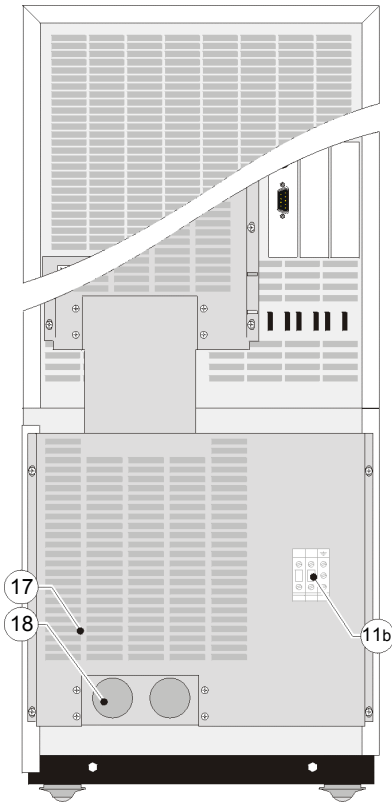
Figure 20. Rear panel of the step-up transformer

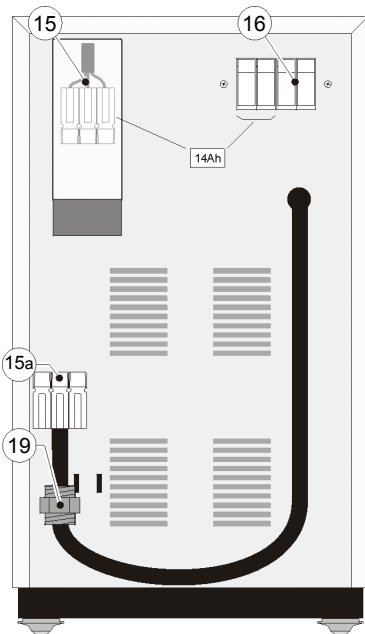

Rear panel of (optional) battery extension pack:

- 15 DC socket (14Ah only)
- 15a DC connector
- 16 Battery fuse holder(s)
7Ah: 2 fuses
14Ah: 4 fuses
- 19 Gland to fasten cable in conduit box of UPS

Figure 21. Rear panel battery extension pack (optional)



5.2 Start-up

The numbers between (brackets) refer to figure 19 in section 5.1.

Note: the UPS can be started on battery power if the utility input voltage is not available or if circuit breaker 'utility' is in off-position: simply skip step 1. To prevent accidental discharging of the batteries, it is however recommended to proceed with step 1 and start the unit only when the utility input voltage is available.

1. Turn breaker 'utility' (8) and breaker 'bypass' (9), both on the rear panel, into position 'on' (up).
2. Some UPS parameters (e.g. voltage, frequency, LCD language) are user selectable. If you want to change one or more settings, please refer to section 5.3.4 'Set-up Menu' now. Changing the settings later is possible, however only after switching off the unit.
3. Turn switch 'UPS on/off' (rear panel, 7) into position 'on' (up). The green LED 'operation' (front panel, 5) will illuminate.

After switching on the UPS performs a self-test and the display (front panel, 1) will show:



```
SELFTEST  
IN PROGRESS
```

After completion of the self-test the output voltage of the UPS is available and the unit is ready for use. The display will show the default screen: model and actual load (values are examples)

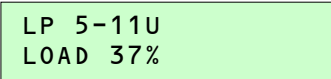

```
LP 5-11U  
LOAD 37%
```

In case of a system failure the self-test results in a failure message; this message is displayed for 30 seconds before the self-test is repeated automatically. If the faulty situation persists, switch off the UPS and contact your dealer. See chapter 9 for more information.

4. Though the batteries (the internal energy reserve) were fully charged when the UPS left the factory, they might have lost some energy during transport and/or storage. It is recommended to allow the UPS to recharge the batteries for a few hours. This way you ensure that the UPS can provide sufficient runtime in case of a utility power failure.
5. If not yet switched on, the equipment connected to the UPS can be switched on now; operate as usual.



5.3 Use

Once the unit is in operation, there is no need to switch the unit on/off during use.

If the manual bypass switch (rear panel, 10) is in position '1', switching off by the on/off switch (rear panel, 7) results in a total absence of the output voltage (also the bypass voltage) of at least 5 secs.

If an emergency shutdown switch has been installed (see 4.5.1.1-2, step 6) the UPS will stop immediately when the switch is opened. Restart is only possible after closing the switch and turning the UPS **off** and **on** again with the UPS on/off switch (rear panel, 7).

The UPS is operated via the push-buttons (front panel, 2-3-4) and the LCD display (front panel, 1). Furthermore the UPS can be controlled via the RS232/contact interface port (rear panel, 12a). For more information see 6.1.

The menus on the display can be divided into 5 groups:

- 1 standard screen
- 2 information menu (5.3.1)
- 3 status- and alarm menu (5.3.2)
- 4 service menu (5.3.3)
- 5 set-up menu (5.3.4)

The *standard menu* shows UPS model and actual load.

```

LP 5-11U
LOAD 37%

```

5.3.1 Information Menu

When the default screen is displayed the first information screen can be entered by depressing the 'up' key (front panel, 4). Using the 'up' and 'down' keys (front panel, 4 and 2) you can scroll through several information screens. After the last information screen the default screen will appear.

The screens display the following information:

```

INPUT LINE  208V
2.45kW      60Hz

```

Utility voltage and utility frequency, and the power delivered by the utility.

```

OUTPUT      208V
LOAD 50%    60.0Hz

```

Output voltages and output frequency, and the power delivered by the UPS (as % of the nominal UPS rating).

```

BATTERY     23°C
271V        1.9A

```

The temperature near the batteries, the battery voltage and the battery current (charging: + value, discharging: - value).

```

AUTONOMY TIME
LEFT 5:27:00

```

The remaining battery runtime (or autonomy) during a utility failure.

```

OPERATING TIME
0YEAR 29DAYS

```

The total operating time of the UPS.



5.3.2 Status and Alarm Menu

The UPS alerts the user with a standard alarm screen that the operating mode has changed and/or that an alarm situation occurs:

ON LINE
ALARM PRESS UP

The actual operating mode, the possible modes are mentioned below. The lower line -if displayed- shows that an alarm occurred. More information can be retrieved with the 'up' key. If no further information is available, the second line is blank.

Possible operating modes:

- ON LINE The normal operating mode. For more information see section 3.2.
- ON BYPASS Overload or failure situation. For more information see section 3.5.
- ON BATTERY For a detailed description of this mode see section 3.3.
- OUTPUT OFF No power is delivered to the load. This can be the result of a command via the RS232 Port, or because no electric energy is available (utility failure, depleted batteries).
- ON MANUAL BYPASS Service mode. For more information see section 3.6.
- on ECO-mode ECO-Mode. See section 5.5.5

Depressing the 'up' key from the standard alarm screen shows, in priority order, which alarms are active,. Scroll through the screens with the 'up' and 'down' keys. Alarm message texts can succeed each other. The following messages are possible:

LOADnotPROTECTED
CAP. C2 DEFECT

The output capacitor C2 is defective. Contact your dealer.

UPS OVERLOADED
REDUCE LOAD

The load exceeds the rated output power of the UPS, and the output voltage can no longer be guaranteed. This text alternates with the following screen:

UPS OVERLOADED
LOAD 143%

showing the actual load as % of the nominal UPS rating. These messages are displayed if the load is > 100%.
If the load exceeds 150% the UPS will immediately switch to bypass, assuming that the conditions for a transfer to bypass are fulfilled. If an overload condition between 100-150% persists, the UPS can eventually also switch to bypass operation due to temperature protection. If a transfer to bypass is inhibited (due to voltage or frequency errors of the utility supply) the UPS may automatically switch off within a few seconds (load dependent). *Output power is lost at that moment.* To avoid these problems, be absolutely certain that the power demands of the protected equipment are within the limits of the UPS.

LOADnotPROTECTED
TEMP TOO HIGH

The temperature of the heatsinks or output transformer is too high. As a result the output voltage may be transferred to bypass.

The operating temperature can rise to intolerable levels as a result of:

- extreme environmental temperature
- lack of proper ventilation
- an overload situation
- fan failure

If the UPS operates in 'on line' mode, it will switch to bypass until the temperature is normal again. If however the UPS operates 'on battery', a shutdown will occur and output power is lost.

LOADnotPROTECTED
VOLTAGE TOO HIGH

The internal DC voltage is too high, internal failure

BATTERY CHARGER
VOLTAGE TOO HIGH

The output voltage of the battery charger is too high, internal failure

BATTERY CHARGER
TEMP TOO HIGH

The battery temperature is too high due to a battery failure or a too high ambient temperature



| | |
|--------------------------------------|--|
| BATTERY CHARGER NO FLOAT | After 24 hours of charging time, the battery voltage did not reach the normal float voltage. This may be caused by faulty batteries, too many battery packs connected or a charger fault. |
| CAPACITOR C1 CAPACITY LOW | The main DC-capacitor needs replacement due to aging or failure |
| LOADnotPROTECTED INVERTER OFF | Due to a failure the output converter's output is not available. As a result the load may have been transferred to bypass. |
| LOADnotPROTECTED BATTERY DEPLETED | The remaining runtime is zero. As a result the load may have been transferred to bypass. |
| LOADnotPROTECTED BATTERY LOW | The remaining run time is less than the set time (standard 2 minutes). This text alternates with the following screen: |
| UPS SHUTDOWN LEFT 2 MINUTES | The output voltage can be lost after the indicated time due to discharged battery. Controlled shutdown of any computer equipment is absolutely necessary at this point. (Using the RS232 or SNMP communications interface, this procedure can be initiated automatically on unattended systems). If the UPS operates at 100% load, the shutdown procedure should be completed within 2 minutes after the 'battery low' alarm started. When the batteries are fully discharged, the UPS is no longer able to power the connected equipment. |
| BYPASS ERROR FUSE FAILURE | The static bypass circuit breaker (rear panel, 9) is in 'off' (down position): no bypass voltage available. Utility voltage is available. If not manually operated, this may have been caused by an overload situation. |
| INPUT ERROR FUSE FAILURE | The utility circuit breaker (rear panel, 8) is in the 'off' (down position): no line voltage available, bypass voltage is available. If not manually operated, this may have been caused by an internal system failure. |
| INTERNAL BATTERY FUSE FAILURE | The internal battery fuse is defective; this may have been caused by an internal system failure. This alarm also appears if no batteries are installed. |
| EXTERNAL BATTERY FUSE FAILURE | The (custom-built) battery extension set has been disconnected from the system: its energy reserve is not available. See 4.5.2 step 12 for details. |
| REPLACE BATTERY | The batteries are (almost) chemically worn out. If the batteries are aged, they must be replaced as soon as possible to ensure full protection for your equipment (see section 8.3). |
| INPUT out LIMITS 137V 60.0Hz | The utility voltage or utility frequency are outside UPS input tolerance (see chapter 10, specifications) |
| BYPASSoutLIMITS 197V 60.0Hz | The utility voltage or utility frequency are outside bypass input tolerance but inside UPS (rectifier) input tolerance (see chapter 10, specifications). Bypass operation is inhibited: if for whatever reason the output converter is unable to deliver the required output, output power is lost. |



INPUT AND OUTPUT
NOT SYNCHRONIZED

The output converter frequency is not synchronized to the utility (input) frequency. In this situation the automatic bypass switch is not able to transfer the load from output converter to bypass and reverse: automatic bypass operation is inhibited: if for whatever reason the output converter is unable to deliver the required output, output power is lost. (see section 3.5). Synchronization is only possible if the utility frequency remains within certain limits (see chapter 10).

BATTERY RUNTIME
LEFT 0:09:41

The remaining runtime. This figure is counted down during battery operation until either the utility returns or the batteries are depleted.

OUTPUT OFF
NO INPUT POWER

The output is switched off due to a faulty situation, indicated by the second line.

PROG. SHUTDOWN
WITHIN 0:09:17

The output will be switched off by a remote command (RS232/SNMP). The second line indicates the time until shutdown.

PROG. SHUTDOWN
LEFT 0:14:03

The output is switched off by a remote command (RS232/SNMP). The second line indicates the time until wake-up.

SHUTDOWN
ALARM PRESS UP

The output is switched off by the 'no-load shutdown' feature: no input voltage and load <2%. If the input voltage is restored, the output will be available again. See also section 5.5.1

IMMEDIATE
SHUTDOWN

The wire on connector J3 pin 3-4 (rear panel, plug-in card 12) is interrupted. The output is no longer available. To restart the unit, restore the connection and turn the on/off switch (rear panel, 7) off and on again.

5.3.3 Service Menu

When the default screen is displayed you can enter the first service screen by depressing the keys 'down' (2) and 'Enter/Reset' (3) simultaneously for approx. 1 second. Using the 'up' (4) and 'down' (2) keys you can scroll through several service screens.

SERVICE SCREENS
ENTER exit

The intro service screen. 'Enter/Reset' returns to the default screen.

SERIAL NUMBER
L051U01/0020A030

The serial number of the UPS.

SOFTWARE VERSION
R2.9; 640777

Release number of the installed software and production code of the UPS.

FAN SPEED 10
INV.DC: + 375

Service information about fan speed (min. 10, max. 30) and internal DC voltage.

HEATSI.TEMP: 0
TRANSF.TEMP: 310

Service information on internal temperature levels, values in mV over the temperature sensors.

FLOAT CHARGE: 1
OUTPUT FAST : 0

First line: service information on charger. '1' = batteries have reached float voltage.
Second line: service information on output converter.



TSTAMP Q4
6028773 1

Service information on internal timer.

FREQ RANGE: 2%
NO LOAD : 1

Frequency tracking range: output converter frequency will follow the bypass frequency within these limits before returning to its own internal frequency. Standard setting: nominal ±2%. Can be changed into nominal ±4% or ±6%. See 5.3.4 Set-up Menu.

No-load shutdown: after a 10 minutes delay the UPS will shut down during utility failure if the load is < 2%. It will restart after the utility returns or when the unit is switched off and on again.

Default setting = 1 (active). For disabling this feature see 5.3.4.

QUICK BATTERY
TEST PRESS ENTER

Start of the manual Quick Battery Test.

See for more information section 5.4.2 'Quick Battery Test'

CALIBRATE BAT
PRESS DOWN+ENTER

Start of the manual Deep Battery Calibration Test.

See for more information sections 5.4.3 'Deep Battery Calibration Test'

PF1 THYRISTOR 1
BATT. THYRISTOR 0

Service information on internal UPS components

VSS THYRISTOR 0
PF1. CONVERTER 1

Service information on internal UPS components

BAT CHARGER 2
INVERTER 1

Service information on internal UPS components

Batt.Charger: 0 = off, 1 = float charging; 2 = top charge, 3 = boost charging, 4 = maintenance charge

LAST TEST TIME
0:00:00

Duration of latest test performed, hh/mm/ss

FORCE BYPASS
press DOWN+ENTER

The UPS transfers the load to bypass when the keys 'down' (2) and 'Enter/Reset' (3) on the front panel are depressed simultaneously for approx. 1 second. If the bypass supply is not within limits, the lower line will show the text 'UNAVAILABLE'.

AUTOMATIC BYPASS
ENABLED

Service set-up information whether the bypass is enabled (default) or disabled. If disabled: UPS will NOT go to bypass. For disabling the bypass refer to the set-up menu (5.3.4).

BATTERY 7Ah
BAT. CHARGE 86%

Service set-up information about the total battery capacity. Information about the actual battery charge condition. For changing the programmed battery capacity refer to the set-up menu (5.3.4).

PLL LOCK SPEED
NORMAL

Service set-up information about frequency tracking speed for the inverter to follow the bypass frequency, LOW (1Hz/sec.) is the normal value and default. HIGH (5Hz/sec.) may be suitable if the UPS is connected to a generator with fast frequency changes and the UPS must be synchronized to prevent alarms. For changing the lock speed refer to the set-up menu (5.3.4).

ECO DISABLED
ENTER/RESET CHNG

Service set-up information about the ECO-mode. By pressing 'Enter/Reset' the ECO-mode can be enabled or disabled, depending on the actual status. In this way the load will be supplied by way of the electronic bypass. If the ECO-mode is disabled the load will be supplied by the inverter. See also 5.5.5.

AUTO RESTART ON
ENTER/RESET CHNG

Service set-up information about the autorestart function. This function can be switched on or off by pressing 'Enter/Reset', depending on the actual status. See also 4.5.6.



5.3.4 Set-up Menu

To enter the set-up menu:

1. Be sure the UPS is switched off.
2. Press push-button 'Enter/Reset' (front panel) and then turn switch 'UPS on/off' (rear panel) into position 'on' (up). Keep Enter/Reset pressed until set-up menu appears.

Using push-buttons 'up' and 'down' you can scroll through the several set-up screens, 'Enter/Reset' confirms a screen choice. After selecting a set-up screen you can scroll through its settings using the push-buttons 'up' and 'down', a setting is confirmed by pressing 'Enter/Reset'. To abort the set-up procedure (i.e. without changing the setting) just wait the 20 seconds time-out period after which the default screen will return.

SETUP SCREENS
ENTER/RESET exit

The intro set-up screen. 'Enter/Reset' returns to the default screen. You can also wait 20 seconds: the time-out period of no key activity.

Pressing 'up' displays the screens in the following order:

WARNING: OUTPUT
CHANGES ON LINE

A short reminder that the new settings will be valid immediately after depressing the 'Enter/Reset' key.

LANGUAGE
ENGLISH

Changes the language of the screen messages: you can select English, German, French, Italian, Spanish.

INPUT VOLTAGE
208V

The system input voltage: Range 120/208/240 Vac.

OUTPUT VOLTAGE
208V

The system output voltage. Range: 120/208/220/230/240 Vac.

OUTPUT FREQUENCY
60.0Hz

The system output frequency. Range: 50/60 Hz.



WARNING! Changing of the output frequency can cause severe damage of equipment connected to the UPS: Be sure that the new frequency is suitable for the connected equipment.

FREQUENCY RANGE
2%

The frequency tracking range (in which the output converter frequency will follow the bypass frequency). Range: 2/4/6 %. If the bypass frequency is beyond the setting, the output converter will return to the fixed crystal controlled frequency.

PLL LOCK SPEED
NORMAL

The frequency tracking speed range (in which the output converter frequency will follow the bypass frequency). Range: NORMAL (1Hz/sec), HIGH (5Hz/sec).

BATTERY CAPACITY
7Ah

Battery capacity. Range: 7 through 590 Ah, in 1 Ah steps.



WARNING! If you proceed, the information about the actual battery condition (as a result of a deep battery test) is lost. For more info see section 5.4.3 'Deep Battery Test'.

FAN CURVE
0

The fan speed. Range: 0 / 1. Proper setting optimizes the cooling capacity of the fans installed. **DO NOT READJUST!** Incorrect setting may lead to reduced lifetime of the power semiconductors.

NO-LOAD SHUTDOWN
YES

Setting 'YES' means that the function is activated: the UPS will switch off during a utility failure when the load is less than 2% of the maximum load. Range: YES/NO.

NOTE: if the UPS operates in parallel the no-load shutdown function is not available. In this case do not activate this function: its setting should read "NO".



AUTOMATIC BYPASS
ENABLED

Controls functioning of the automatic bypass switch. Range: ENABLED/DISABLED. If the UPS is used as a frequency converter you may change the setting to 'DISABLED'. Bypass operation will then be inhibited and all alarms related to 'bypass out of limits' are suppressed.

SERVICE WARNING
DISABLED

The system can prompt for service to a user defined schedule. Range: 8/12/16/20/24/28 months or DISABLED. To reset the timer: first select "DISABLED" and subsequently set a new alarm interval.

5.4 Test Screens

These screens show the test procedure, either started from the service menu (front panel keys) or via the UPS monitoring software (RS232/SNMP). The upper line indicates the kind of test, the second line its status.

Upper lines:

second line:

| | | |
|-----------------------|------------------------|--|
| GENERAL SYSTEM | TEST START | the test will start soon |
| QUICK BATTERY | TEST ACTIVATED | the test is running |
| CALIBRATE BAT | TEST SUCCESSFUL | the test has been completed successfully |
| BYPASS | TEST FAILED | the test has not been completed successfully |

5.4.1 Battery Test, general

Automatic test: Every 500 operating hours the UPS conducts automatic battery tests to ensure that the batteries and the wiring are able to support power failures. The tests do not cause any interruption in the functioning of the unit.

Manual test: A manual battery test can be activated

- either through an interface kit, via the RS232 or SNMP Interface Port (please refer to the manual of your interface package), or
- via the front panel: see below

5.4.2 Quick Battery Test

From the standard menu first enter the service menu (press the 'down' and 'Enter/Reset' keys simultaneously, then press the 'down' key until the following screen appears:

QUICK BATTERY
TEST PRESS ENTER

The 'Enter/Reset' key confirms the selection, and the screen shows:

QUICK BATTERY
TEST START

The test status (indicated by the second line) can be:

| | | |
|------------------------|---|--|
| TEST ACTIVATED | = | testing |
| TEST SUCCESSFUL | = | battery has been tested with positive result |
| TEST FAILED | = | the batteries should be replaced |
| NOT AVAILABLE | = | battery capacity too low to start the test |

If the batteries are dangerously close to being worn out, a low priority alarm 'replace battery' will be generated. The batteries must be replaced as soon as possible (see section 8.3).

NOTE: If the manual test is started immediately after installation or after a power failure, the UPS may generate a false 'replace battery' alarm as the batteries have been (partly) discharged during transport/storage or during the power failure.



5.4.3 Deep Battery Test

The runtime as shown on the LCD screen is calculated, and the value is initially based on the capacity of new batteries. As batteries age, their capacity deteriorates, and as a result the initial battery capacity may be too unreliable for a proper runtime prediction. The UPS is able to keep track of the aging process, if a 'deep battery test' (battery calibration test) is executed regularly. During such a test the condition of the batteries is tested, and the result of the test is stored, and used by the UPS system for future runtime calculations.

We advise performing a deep battery test on a regular basis. For accuracy reasons the interval should depend on the number of discharges. With one discharge per month a 6 month interval is sufficient. If the discharge interval is shorter than once a week a monthly deep battery test is advised.

A deep battery test can be started only if the following conditions are met:

- The load should be more than 30% of nominal load
- The batteries should be fully charged (100% on screen)
- There are no alarms at the time the test is started.

Procedure:

From the standard menu first enter the service menu (press the 'down' and 'Enter/Reset' keys simultaneously for 2 seconds). Subsequently press the 'down' key until the following screen appears:

```
CALIBRATE BAT
press DOWN+ENTER
```

Press the keys 'down' (2) + 'Enter/Reset' (3) simultaneously, for at least 1 second.

The following screen appears:

```
CALIBRATE BAT
TEST ACTIVATED
```

The test is executed, this may take a few minutes with standard battery and full load. Partial load and/or batt. extension packs can lengthen the test period considerably. Do not change the load during the test, i.e. do not switch off or on connected equipment!

The deep battery test discharges the batteries to 'battery low' alarm level (see section 5.3.2 'battery low'). Please note that immediately after a deep battery test the expected run time is very short: allow the UPS to recharge its batteries.

After the test the second line informs about the result:

| | | |
|------------------------|---|--|
| TEST SUCCESSFUL | = | The test has been completed successfully |
| TEST FAILED | = | The test could not be executed properly: not all test conditions were fulfilled. <i>The UPS system was not informed about the actual battery condition!</i> |



5.5 Other Features

5.5.1 Shutdown

'Remote shutdown': Using communication capabilities, the computer can direct the UPS to turn itself off following controlled shutdown of the system. Subsequently the UPS will remain off for at least a few seconds (see also 6.1). LED *'operation'* will blink green. The unit will start up again as soon as the utility returns.

'No-load shutdown': The UPS will also switch off if the load is < 2% of the maximum load, and the input is absent for more than 10 minutes. For more information see section 5.3.2, message 'SHUTDOWN ALARM'.

NOTE: If the UPS operates in parallel, the no-load function is not available.

'Emergency shutdown': for more information see section 5.3.2, message 'IMMEDIATE SHUTDOWN'.

5.5.2 Utility start

The UPS is able to start, even if the batteries are not connected. Alarm messages 'BATTERY FUSE FAILURE' and 'BATTERY DEPLETED' will be shown. The run time is zero.

5.5.3 Sleep and wake-up

GE Digital Energy™ UPS monitoring software allows you to program a 'sleep period' of the UPS by sending two commands to the UPS:

- shut down after # minutes, and subsequently:
- shut down during # hours.

After the first command the following screen appears:

```

PROG. SHUTDOWN
WITHIN 0:09:17

```

During the sleep period the output voltage is no longer available. LED *'operation'* blinks green, and the LCD screen shows the time left until restart:

```

PROG. SHUTDOWN
LEFT 0:14:03

```

If a utility failure occurs during the sleep period and the battery voltage eventually drops below 200Vdc, the UPS will automatically switch off in order to save battery power. When the main returns the UPS will start up automatically. The programmed sleep time however is lost.

The sleep period can be cancelled by either turning the UPS ON/OFF switch (6) off for a few seconds or by sending the appropriate command via the RS232/SNMP port.

5.5.4 Overload protection in bypass mode

The UPS will protect itself in case of overload. Upon an overload which is caused by abnormal circumstances the UPS will switch to bypass operation, and subsequently the bypass input fuse on the front panel will trip. The capacity of the bypass fuse allows it to handle the inrush currents of the equipment connected to the UPS. The fuse will only trip after more than an hour at an input current of 40Amp (LP 5/6-11U) or 50Amp(LP8-11U) or 63Amp (LP 10-11U).

In order to protect the UPS system the software will cut off the abnormal current:

| | in 10 minutes: | in 1 minute: |
|-------------|----------------|--------------|
| LP 5/6-11U: | 36Amp | 49Amp |
| LP 8-11U: | 55Amp | 65Amp |
| LP 10-11U | 70Amp | 81Amp |

Between 36-49Amp(LP 5/6-11U), 55-65Amp (LP 8-11U), 70-81Amp(LP 10-11U) the time is inversely proportional to the input current. We advise to place a distribution fuse slow blow type between UPS input and the utility supply. Please refer to the installation drawing.



5.5.5 ECO-mode

The UPS is equipped with the 'ECO-mode' feature. If the feature is enabled, the load is operated on utility through the electronic bypass switch. If the utility is interrupted or out of limits the load is automatically transferred to the inverter. Operating the load on utility improves the efficiency of the UPS with 5-8% and saves on energy costs. We advise not to use the ECO-mode in case of an unstable utility.

After enabling the ECO-mode (please refer to service screens 5.3.3) the *standard menu* changes to:

```
LP 5-11U
LOAD 37%      ECO
```

NOTE: If LP-U units operate in parallel, the ECO-mode feature is not available.

5.5.6 Auto restart

If this feature is enabled and the unit has shut down (e.g. due to overload) the UPS will start up automatically when the normal situation is restored. The off-factory setting is: enabled.

If the auto restart feature is disabled the unit will not automatically restart when the normal situation is restored but the display will show:

```
AUTO RESTART OFF
PRESS ENTER
```

After 'Enter' the unit will restart. See also 5.3.3 'service screens'.

5.5.7 Superior Battery Management

- **Load dependent battery-end voltage:** The allowable final battery voltage depends on the discharge current: the higher the current, the lower the 'end-of-discharge' battery voltage. This gives maximum capacity without over discharging. Over discharging results in failure to recover normal capacity and in shortened battery life.
- **Equalize mode:** When switched on for the first time the UPS will start boost-charging the batteries for 15 hours in order to equalize all battery voltages.
- **Boost mode:** If after a discharge the battery voltage is lower than 240Vdc, the UPS will charge the batteries with a boost charge voltage of 285Vdc. This enables fast recharging of the batteries. The programmed battery charging mode will change from boost charge into float charge after boost charging twice.
- **Temperature compensated battery charging:** This feature reduces the battery charge voltage with increasing temperature (-18mV/°C or -32.4mV/°F per 12V battery). As a result poor charging of the batteries under low temperature conditions and overcharging of the batteries under high temperature conditions are prevented.



6 - Interfacing Features

The UPS is equipped with 3 'option slots' (rear panel, 12-14). In the most left slot (12) an RS232/contact interface card is factory installed. See 5.1. In the middle slot (13) additional Relay or SNMP plug-in Cards can be installed. The most right slot (14) allows easy installation of an RPA plug-in Card (Redundant Parallel Operation).

6.1 RS232 / contact interface

The RS232/Contact interface (9-pole, sub D, rear panel, 12a) enables advanced communication between the UPS and e.g. a personal computer. An interface kit (cable and software) is delivered with the UPS. The software supports most common operating systems incl. Novell, UNIX, VMS, Windows 3 - 95/98/2000 - NT, IBM OS/2, LINUX, has a modular and layered architecture and works for all degrees of network complexity: stand-alone, multi-vendor networks and large managed networks.

During a power failure the UPS software takes a number of actions: processes are stopped, open files are closed and unattended systems will be shut down in a controlled way. When the utility power returns, the systems will automatically start up and will be up and running as soon as possible.

For specific information on **GE Digital Energy™** connectivity products please contact your dealer or internet: www.gedigitalenergy.com.

| Pin # | Function |
|-------|-------------------------------|
| 1 | Battery low |
| 2 | Serial data out |
| 3 | Serial data in / UPS shutdown |
| 4 | Not used |
| 5 | Common |
| 6 | Bypass active |
| 7 | Plug&Play / RTS |
| 8 | Utility failure |
| 9 | General alarm |

contact interface: Max 48V / 30mA

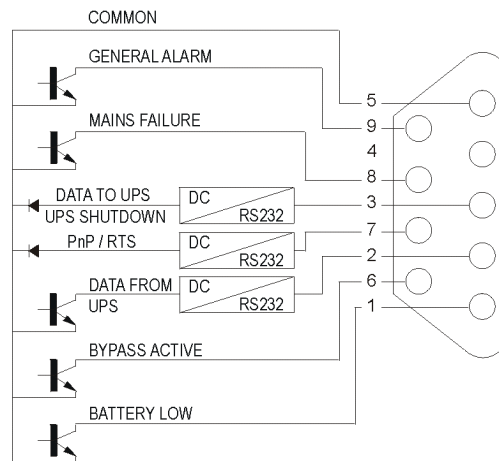

Fig. 22: RS232 / contact interface

6.2 Emergency shutdown

The emergency shutdown connector is located on the RS232/contact interface card (12). Be sure that the UPS is switched off, and remove the card from the unit*. Remove the wire from connector J3 (pin 3 and 4). Install the wiring of a normally closed contact to connector J3 (pin 3 and 4). Re-install the RS232 interface card. If during normal operation of the UPS the contact is opened, the UPS will shut down. To restart the unit, restore the connection and turn the UPS off and on again.

* If the card is removed during normal operation the UPS will shut down.

6.3 Relay Card (optional)

The relay plug-in card can be installed in the middle option slot (rear panel, 13). The card is provided with four potential free contacts representing: battery low, bypass active, utility failure and general alarm. For more information please refer to the user manual that comes with the interface card.

6.4 SNMP Interface (optional)

This SNMP plug-in card can be installed in the middle option slot (rear panel, 13). The card makes the UPS 'SNMP manageable': it allows the data interface to be connected directly to an Ethernet network (thin coax, twisted pair, AUI). For more information please refer to the user manual that comes with the interface card. When this option is installed the RS232 communication link is no longer available.



7 - Optional Features

7.1 Extended Runtime

Extended runtime versions are equipped with additional separate battery packs to increase the runtime of the unit. Additional batteries will increase the recharging time for the unit. All other operational information is the same.

If a battery pack is connected, the UPS must be informed about the new total battery capacity to allow a reliable recalculation of the available run time. Please refer to section 5.3.4 'Set-up Menu'. Dependent of the charge condition of the new batteries the new run time calculations may temporarily be unreliable.

Connecting an external charger may cause damage to the UPS. As the batteries are not galvanically separated from the utility input, the external charger must be galvanically separated from the utility. Using an external charger will cause a false run time prediction during charging time, the correct run time will be shown 10 hours after reaching battery float charge. If you are in doubt, contact your dealer.

Battery pack A: 240V / 7 Ah
Battery pack B: 240V / 14 Ah

| Batt. pack(s) | cap. of batt. pack(s) (Ah) | tot. cap. incl. internal battery (Ah) | | runtime (minutes), at 100% / 50% load | | | |
|---------------|----------------------------|---------------------------------------|---------|---------------------------------------|--------|--------|-------|
| | | 5/6-11 | 8/10-11 | 5-11 | 6-11 | 8-11 | 10-11 |
| | | - | - | 7 | 12 | 10/25 | 8/20 |
| A | 7 | 14 | 19 | 25/60 | 21/50 | 22/50 | 16/39 |
| B | 14 | 21 | 26 | 45/90 | 35/75 | 33/70 | 25/57 |
| A+B | 21 | 28 | 33 | 60/120 | 50/100 | 44/90 | 34/70 |
| B+B | 28 | 35 | 40 | 80/150 | 65/130 | 55/110 | 43/90 |

For more information please refer to the **NOTES** in section 4.5.5 step 6.

7.2 Plug-in Cards

An option slot (rear panel, 13) allows easy installation of a relay or SNMP plug-in card. See sections 6.3 and 6.4 for more information.

7.3 RPA-Facility (Redundant Parallel Architecture)

Nowadays there are many mission-critical applications that need a fault tolerant, 100 % reliable availability of mains power. By adding the RPA-facility to the UPS (rear panel, 14), highest standards for reliability can be met. The RPA-facility allows to connect 2, 3 or 4 units in parallel.

Connecting GE Digital Energy™ LP-U units in parallel is attractive for several reasons.

Redundancy: To achieve the highest possible level of power protection in a fault-tolerant network. By connecting units in parallel, using the N+x system, a redundant system can be created. In this case all the UPSs equally share the load in the system during normal operation. In this way every possible single point of failure will be eliminated. This means that if one of the UPSs in the parallel system fails, the other(s) can still supply the load guaranteeing full protection without any interruption.

Scalability: To add power if needed without investments beforehand. Another reason for paralleling units is upgrading the power rating of the system. If e.g. a LP 5kVA is installed, the power rating can be upgraded to 10kVA by adding another LP 5kVA in parallel. This spread investment makes sure that you don't have to invest in advance, but only when you need to.

GE's unique RPA system has the following major advantages:

- RPA offers true redundancy because not only the power electronics are redundant, but also the batteries, the bypass circuit and the control logic,
- The RPA system is an option: you don't have to buy it if you don't need it.



7.4 PDM: Power Distribution Module

This Power Distribution Module (PDM) contains 4 x Nema 5-20R, 2 x Nema L6-30R and 1 x Nema L14-30 R Power sockets (see fig. 23). The PDM replaces the conduit box (17), and converts the LP-U into a pluggable UPS. Only qualified personnel is allowed to install the PDM.

For more information please refer to the user manual that comes with the Power Distribution Module.

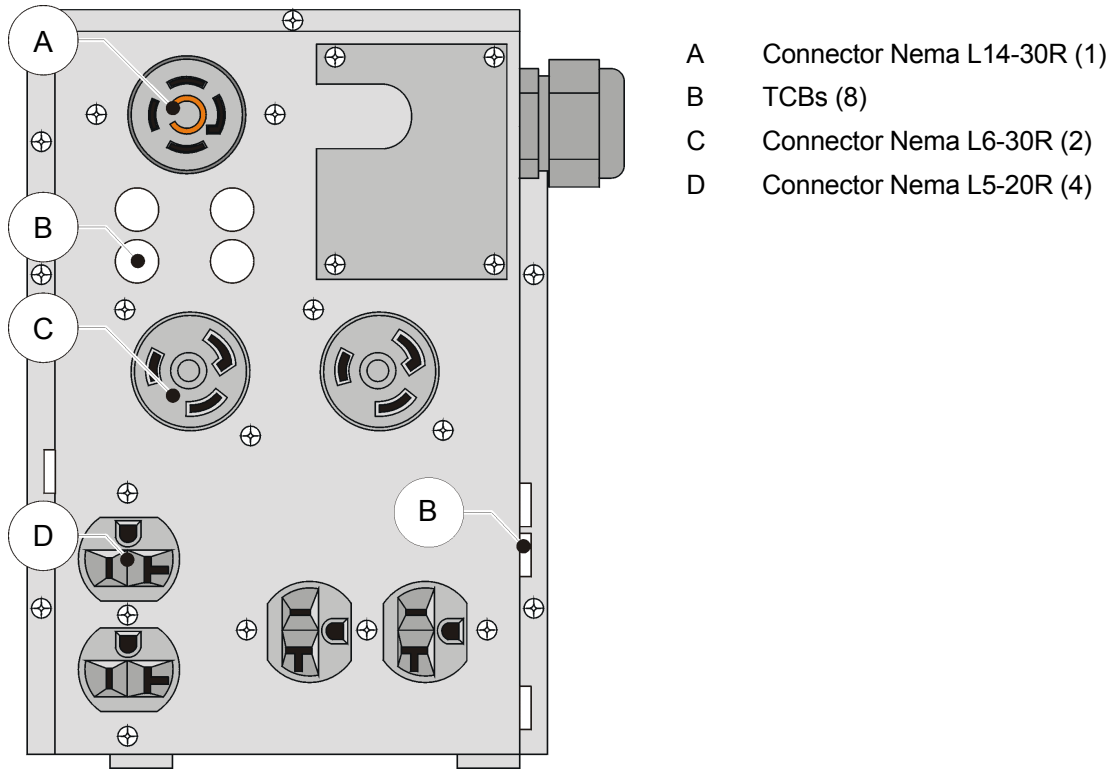

Fig. 23: Power Distribution Module

7.5 Seismic anchors

Seismic anchors can be ordered separately; contact your local dealer.



8 - Maintenance

8.1 General

When used properly, the UPS is virtually maintenance free other than keeping the air inlets/outlets free from dust.

8.2 Cooling fan

The expected operational life of the cooling fans is approximately 20,000 to 40,000 hours of continuous operation. A high ambient temperature will shorten this operational life.

8.3 Batteries

The service life of the battery is from 3 to 6 years, depending on the operating temperature and on the number of discharge cycles.

As a healthy battery is essential to the performance of the UPS, an automatic battery test is performed regularly to ensure failsafe operation (see section 5.4.1). When the condition of the battery is critical, the warning signal will be activated (buzzer 1x per 8 secs, and alarm message 'Replace battery', see 5.3.2). The batteries must be replaced as soon as possible. Please contact your dealer. **Use only UL recognised batteries (BAZR2), valve regulated types.**

NOTE: under certain circumstances a *manual* battery test can result in a false alarm: please see section 5.4.2 'QUICK BATTERY TEST'.

Regular deep battery tests are advised in order to re-calibrate the capacity of aging batteries. See section 5.4.3 for more information.



NOTE: All maintenance and service work, including battery replacement, should be performed by qualified service personnel.

For authorized service personnel only:

Never short the battery terminals. Shorting may cause the battery to burn. Avoid charging in a sealed container. Proper disposal of batteries is required: refer to your local codes for disposal requirements. Never dispose of batteries in a fire: they may explode. Never disassemble or reassemble batteries; their contents (electrolyte) may be extremely toxic. If exposed to electrolyte, wash immediately with plenty of water, if eye contact occurs flush with water and contact a physician.

8.4 Safety



CAUTION:

When the LP-U UPS is operating, all parts of the electronics are directly connected to the utility and high voltages are present on all internal parts, including the battery. Even after disconnection from the utility, all parts inside the UPS, including the battery, conduct dangerous voltages (except the RS232 output).

For your safety, only authorized service personnel may remove the cabinet cover.

8.5 Storage

Always store the UPS in a dry location with the batteries in a fully charged state, storage temperature must be within -20 and +45°C. Storing the unit for a period exceeding 3 months can reduce the life of the batteries. To maintain their normal life expectancy, the batteries must be recharged periodically:

- if the storage temperature is within -20 and +30°C (-4°F and 86°F): every 6 months, for 24 hours,
- if the storage temperature is within -20 and +45°C (-4°F and 113°F): every 4 months, for 24 hours.

8.6 Recycling the UPS at the end of service life



NOTE: This product has been designed to respect the environment, using materials and components respecting eco-design rules. It does not contain CFCs (Carbon Fluorine Chloride) or HCFCs (Halogen Carbon Fluorine Chloride).



GE Digital Energy, in compliance with environment protection recommends that the UPS equipment, at the end of its service life, must be recycled conforming to the local applicable regulations.



WARNING

The batteries contain lead, which is a dangerous substance for the environment. Therefore the batteries must be recycled correctly by specialized companies.



9 - Troubleshooting

Whenever a malfunction occurs, first check external factors (e.g. connections, temperature, humidity or load) to determine whether the problem is caused by the unit itself or by its environment. Subsequently check whether the breakers/switches on the rear panel (fig. 19, 7-8-9) are in 'on' position. Always check these external factors before concluding that your UPS is faulty.

The front screen will indicate the problem and solution (if the problem is due to environmental circumstances). If the solution is not shown on the screen, please contact your dealer.

During the self-test, performed immediately after start-up, the UPS may detect a system failure. In this case a message is displayed for 30 seconds before the self-test is repeated. If the faulty situation persists, please contact your dealer.

(One of) the following messages can be displayed:

SELFTEST FAILURE
PCB POWER SUPPLY

One or more voltages of the internal power supply is (are) outside tolerance. Please contact your dealer.

SELFTEST FAILURE
AC ON INPUT

An external AC voltage (not the UPSs output voltage) was detected on the output terminals. Please contact your dealer.

SELFTEST FAILURE
INT.BATTERY FUSE

The internal battery fuse is defective. Please contact your dealer.

SELFTEST FAILURE
EXT.BATTERY FUSE

The battery extension circuit breaker is in 'the off' position. Please switch it to 'the on' position.

SELFTEST FAILURE
BATTERY CHARGER

Malfunction of the battery charger. Please contact your dealer.

SELFTEST FAILURE
U_{ic} TOO HIGH

Malfunction of the input circuit: voltage delivered is too high. Please contact your dealer.

SELFTEST FAILURE
TEMP TOO HIGH

The temperature of (one of) the components is (still) too high. See section 5.3.2.

SELFTEST FAILURE
U_{ba} TOO LOW

The battery voltage is too low to allow start-up. Wait for a few hours, leave the UPS switched on.*

SELFTEST FAILURE
U_{ic} TOO LOW

Malfunction of input circuit: voltage delivered is too low. The batteries may be faulty or depleted. Wait for a few hours, leave the UPS switched on.*

SELFTEST FAILURE
Q4 NOT OK

Hardware output voltage detection 'Q4' is active. Please contact your dealer.

* If absence of input power (utility failure, maintenance work) is expected to last longer than a few hours, switch off the UPS to save battery power. If the UPS input power is absent for several days and the UPS remains on under no-load conditions, the batteries can be discharged very deeply, resulting in a short battery life time.



10 - Specifications

| | | | | | |
|-------------------------------|---|---|--------------|--------------|---------------|
| UPS Type | : | 5-11U | 6-11U | 8-11U | 10-11U |
| Output power (kVA/kW) | : | 5/4 | 6/4.8 | 8/6.4 | 10/8 |
| AC input voltage | : | 120/208/240 Vac (120V only with step-up transformer for LP 5/6-11U) | | | |
| Input frequency | : | 60/50 Hz | | | |
| AC output voltage | : | 120/208/220/230/240V | | | |
| Output frequency | : | 60 or 50 Hz, std. 60 Hz; selectable on front | | | |
| System efficiency (full load) | : | 87% | | | |
| Line input breaker (C-type) | : | 32A | 32A | 50A | 63A |
| Bypass input breaker (C-type) | : | 32A | 32A | 50A | 63A |
| Battery safety fuse (F4A) | : | 30A | 30A | 30A | 30A |
| Battery safety fuse (F4B) | : | 30A (spare) | 30A (spare) | 30A | 30A |
| Internal safety fuse (F5A) | : | - | - | 30A | 30A |
| Internal safety fuse (F5B) | : | 30A | 30A | 30A | 30A |
| Input/output connectors | : | terminals at rear of unit | | | |

INPUT

| | | | | | |
|---|---|-------------|-------|-------|------|
| AC input voltage range (208V-240V) | : | | | | |
| at 100% load | : | 162 - 285 V | | | |
| at 50% load | : | 146 - 285 V | | | |
| at 20% load | : | 133 - 285 V | | | |
| AC input voltage range (120V, L5/6-11U) | : | | | | |
| at 100% load | : | 81 - 141 V | | | |
| at 50% load | : | 72 - 141 V | | | |
| at 20% load | : | 66 - 141 V | | | |
| Input frequency range | : | 40-70 Hz | | | |
| Input current wave form | : | sinusoidal | | | |
| Input power factor | : | ≥ 0.99 | | | |
| Max. input current at 100% load | : | 120V | 43.3A | 50.8A | n.a. |
| | : | 208V | 25.0A | 30.0A | 40.5 |
| | : | 240V | 21.4A | 25.1 | 34.8 |
| Inrush current | : | none | | | |
| Rectified DC voltage out | : | 380 V | | | |

BATTERY CHARGER

| | | | | | |
|----------------------------|---|--|-----|-----|-----|
| Characteristic | : | U/I-characteristic, constant current charging until boost/float voltage, then constant voltage charging and boost charge mode for fast recharging of batteries | | | |
| DC input voltage range | : | 350-450 V | | | |
| DC output voltage at 20 °C | : | float: 273 V boost: 295 V | | | |
| Output current limit (Adc) | : | 2.0 | 2.0 | 3.0 | 3.0 |

OUTPUT CONVERTER

| | | | | | |
|------------------------------------|---|--|------|------|-------|
| Output power at pf. = 0.8, VA* | : | 5000 | 6000 | 8000 | 10000 |
| Semiconductor | : | IGBT | | | |
| AC output voltage | : | 120/208/240V ± 1% static resistive load 120/208/240V ± 2% measured crest load 2.5:1 120/208/240V ± 2% dynamic mean deviation over one half cycle for 100% of rated load applied or removed | | | |
| Typical overload (temp. dependent) | : | 110% ≥ 20 minutes 130% ≥ 3.5 minutes 150% ≥ 2 minutes | | | |
| Output frequency | : | 60 or 50 Hz selectable, ± 0.1%, unless synchronized with the utility | | | |
| Freq. tracking range | : | ± 2/4/6% of nominal, user selectable | | | |
| Output wave form | : | sine wave | | | |
| Max. phase difference input-output | : | max 7° | | | |
| Harmonic distortion | : | 2% max. with linear load | | | |
| Power factor range | : | Any lagging or leading power factor permitted within the specified rating to pf. 0.5 | | | |
| Output derating altitude | : | Till 1000m no derating Above 1000m 12.5% per 1000m, max. 4000m | | | |
| Protection | : | Automatic shut down (or transfer to bypass, if bypass is available) in case of - low/high DC voltage - overtemperature - overload / short circuit | | | |

The output is protected against connection to the utility supply

* according to EN 50091-1



UPS Type : 5-11U 6-11U 8-11U 10-11U

AUTOMATIC BYPASS SWITCH

The automatic switch provides transfer of the load to the utility voltage without any interruption of the supply. The transfer is initiated by a signal from the output converter protection circuit in case of an overload or high temperature. When the conditions return to normal the load is automatically transferred back to the output converter. The automatic bypass switch can be disabled by the end-user.

- Bypass voltage limits : -15%, +10% of nominal
Transfer transients : typically 2% mean deviation over one half cycle.
Frequency tracking range : ± 2/4/6% of nominal (user selectable)
Slew rate : max. 1Hz/sec or 5Hz/sec (user selectable)

BATTERY

- Battery type : Sealed and maintenance free
Nominal voltage (V) / capacity (Ah) : 12/7 12/7 12/12 12/12
Number of batteries : 20 20 20 20
Capacity of standard battery set : 7Ah 7Ah 12Ah 12Ah
Battery recharge time : 1.5 - 3 hours for 80% capacity
Battery service life : up to 6 years (depending on operating conditions)
Battery discharging : self discharge current ≤ 0.35 mA
discharge end voltage of the battery depending on the actual load
10.5Vdc < 0.2 CA till 9.0 Vdc > 2 CA
When the UPS is in sleeping mode the inverter will be switched off, battery charger and rectifier are in operation

Table with 4 columns: Runtime in minutes, VA / Watts, and values for different load configurations (1000/800, 2000/1600, 3000/2400, 5000/4000, 6000/4800, 8000/6400, 10000/8000).

BATTERY EXTENSION PACKS

- Sheet steel cubicle : VSDA1
Dimensions (hxwx, mm) : 537x313x590
Dimensions (hxwx, inch) : 21.1x12.3x23.2
Battery : 240Vdc/7Ah or 240Vdc/14Ah
Weight with battery (Kg) : 73 or 123
Weight with battery (Lbs) : 161 or 271

Table for Battery pack A (voltage V / capacity Ah) with columns for 240/7, 240/7, 240/7, 240/7 and rows for Total capacity (Ah), Typical runtime, 100% / 50% load, min., and Number of packs required.

Table for Battery pack B (voltage V / capacity Ah) with columns for 240/14, 240/14, 240/14, 240/14 and rows for Total capacity (Ah), Typical runtime, 100% / 50% load, min., and Number of packs required.

For more info see section 7.1

STEP-UP TRANSFORMER CABINET MOUNTED UNDERNEATH VSD2 (FOR LP 5/6-11U ONLY)

- Sheet steel cubicle : VSDT2 + VSD2
Dimensions (hxwx, mm) : 995x313x730
Dimensions (hxwx, inch) : 39.2x12.3x28.7
Weight (Kg) : 175 Kg
Weight (Lbs) : 386 Lbs



UPS Type : **5-11U** **6-11U** **8-11U** **10-11U**

ENCLOSURE

| | | | | | |
|---|---|---------------------|----------------|----------------|----------------|
| Sheet steel cubicle | : | VSD2 | VSD2 | VSD2 | VSD2 |
| Colour front | : | RAL 9006 (aluminum) | | | |
| Colour cabinet | : | RAL 9010 (white) | | | |
| Protection | : | IP 20 | | | |
| Dimensions (hxwxd, mm) | : | 680x313x730 | 680x313x730 | 680x313x730 | 680x313x730 |
| Dimensions (hxwxd, inch) (height with castors) | : | 26.8x12.3x28.7 | 26.8x12.3x28.7 | 26.8x12.3x28.7 | 26.8x12.3x28.7 |
| Weight (with batteries, Kg) | : | 134 kg | 134 kg | 175 kg | 186 kg |
| Weight (with batteries, Lbs) | : | 295 Lbs | 295 Lbs | 386 Lbs | 410 Lbs |

GENERAL DESIGN CRITERIA

| | | |
|------------------|---|---|
| Mechanical | : | IP20 |
| Humidity | : | 95% non condensing |
| Safety | : | UL 1778; 2001, C-UL EN 50091-1-1: 1999; EN 60950 / IEC 950: 2001 |
| Surge capability | : | 6kV 1.2/50µs; 3kA 8/20µs |
| EMC | : | FCC part 15, class A; EN 50091-2 |

ENVIRONMENT

| | | |
|--------------------------|---|--|
| Ambient temperature | : | -10 to +40°C (14 to 104°F) |
| Audible noise at 1 meter | : | 40 - 50dB(A), the audible noise is load and temperature dependent |



Dimensions Conduit Box

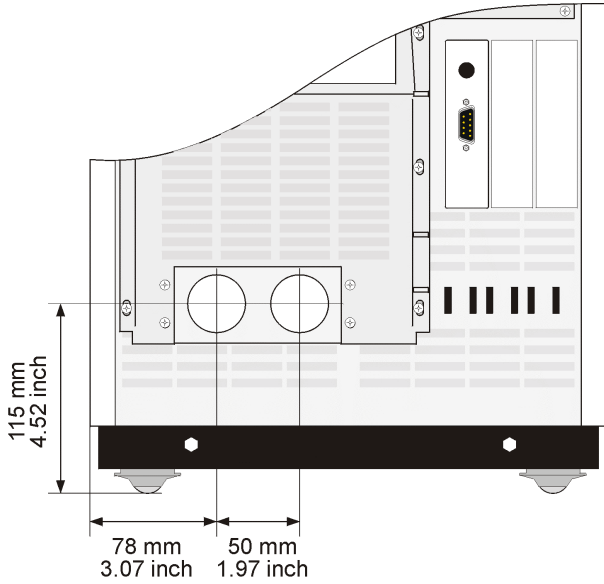

Frontal connection

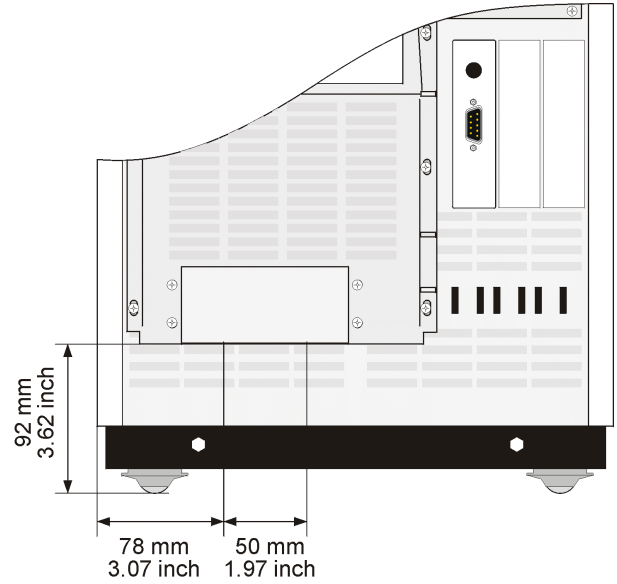

Connection from below

Center of Gravity

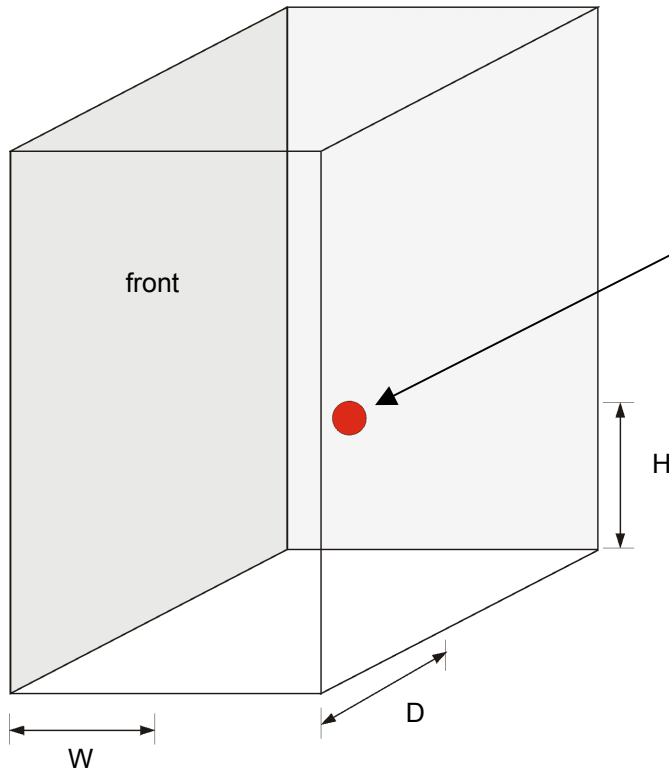

UPS cabinet, dimensions hwxwd:
680 x 310 x 710 mm
26.8 x 12.3 x 28.7 inch

Center of gravity, position:
H = 275 mm / 10.8 inch
W = 155 mm / 6.1 inch
D = 300 mm / 11.8 inch



LP 5/6/8/10-11U installation drawings

| Model | Heat dissipation Linear load 240 Volt | | | | Dimensions | | | Weight | Air flow 100% load | Amb. temp. | Rel. humidity non-cond. | Altitude (max 4000m) | Input wiring | | | Output wiring | | |
|------------|--|--------|----------|--------|------------|------|------|--------|--------------------------|---------------|-------------------------------|-----------------------------------|-----------------------|-----------------------|-----------------------|----------------------|----------------------|----------------------|
| | 100% load | | 50% load | | h | w | d | | | | | | utility volt. 120V | utility volt. 208V | utility volt. 240V | output volt. 120V | output volt. 208V | output volt. 240V |
| LP-U | W | Btu/hr | W | Btu/hr | Inch | Inch | Inch | Lbs | m3/hr | °F | | m | AWG/mm ² | AWG/mm ² | AWG/mm ² | AWG/mm ² | AWG/mm ² | AWG/mm ² |
| 5-11 | 571 | 1950 | 389 | 1329 | 26.8 | 12.3 | 28.7 | 295 | 660 | 14-104 | <95 | <1000, derating 12.5% per 1000 | N.A. | 10/6 | 10/6 | 8/10 | 10/6 | 10/6 |
| 6-11 | 661 | 2254 | 381 | 1300 | 26.8 | 12.3 | 28.7 | 295 | 660 | 14-104 | <95 | | N.A. | 8/10 | 10/6 | 8/10 | 10/6 | 10/6 |
| 8-11 | 948 | 3234 | 551 | 1882 | 26.8 | 12.3 | 28.7 | 386 | 660 | 14-104 | <95 | | N.A. | 6/14 | 8/10 | 6/14 | 8/10 | 8/10 |
| 10-11 | 1090 | 3719 | 556 | 1896 | 26.8 | 12.3 | 28.7 | 410 | 660 | 14-104 | <95 | | N.A. | 4/22 | 6/14 | 4/22 | 8/10 | 8/10 |
| 5-11/120 V | 641 | 2187 | 425 | 1451 | 39.2 | 12.3 | 28.7 | 386 | 660 | 14-104 | <95 | | 6/14 | N.A. | N.A. | 8/10 | 10/6 | 10/6 |
| 6-11/120 V | 744 | 2539 | 601 | 2051 | 39.2 | 12.3 | 28.7 | 386 | 660 | 14-104 | <95 | | 4/22 | N.A. | N.A. | 8/10 | 10/6 | 10/6 |

| Model | Minimum free space required (Inches) | | | Distance between mounting holes (Inches) | | | Input overcurrent protection (AMPS) | | | Output overcurrent protection (AMPS) | | | |
|------------|---|------|------|---|-------|------|--|------|------|--------------------------------------|--------------|------|------|
| | front | side | rear | x | y | z | 120V | 208V | 240V | 120V (1 X) | 120V (2X) | 208V | 240V |
| LP-U | | | | | | | | | | | | | |
| 5-11 | 4 | 2 | 8 | 7.24 | 22.76 | 7.48 | | 35 | 30 | 40 | 20 | 25 | 20 |
| 5-11 /120V | 4 | 2 | 8 | 7.24 | 22.76 | 7.48 | 60 | | | 40 | 20 | 25 | 20 |
| 6-11 | 4 | 2 | 8 | 7.24 | 22.76 | 7.48 | | 40 | 35 | 50 | 25 | 30 | 25 |
| 6-11 /120V | 4 | 2 | 8 | 7.24 | 22.76 | 7.48 | 70 | | | 50 | 25 | 30 | 25 |
| 8-11 | 4 | 2 | 8 | 7.24 | 22.76 | 7.48 | | 60 | 45 | 70 | 35 | 40 | 35 |
| 10-11 | 4 | 2 | 8 | 7.24 | 22.76 | 7.48 | | 70 | 60 | 80 | 40 | 50 | 40 |



LP 5/6/8/10-11U 208-240V input

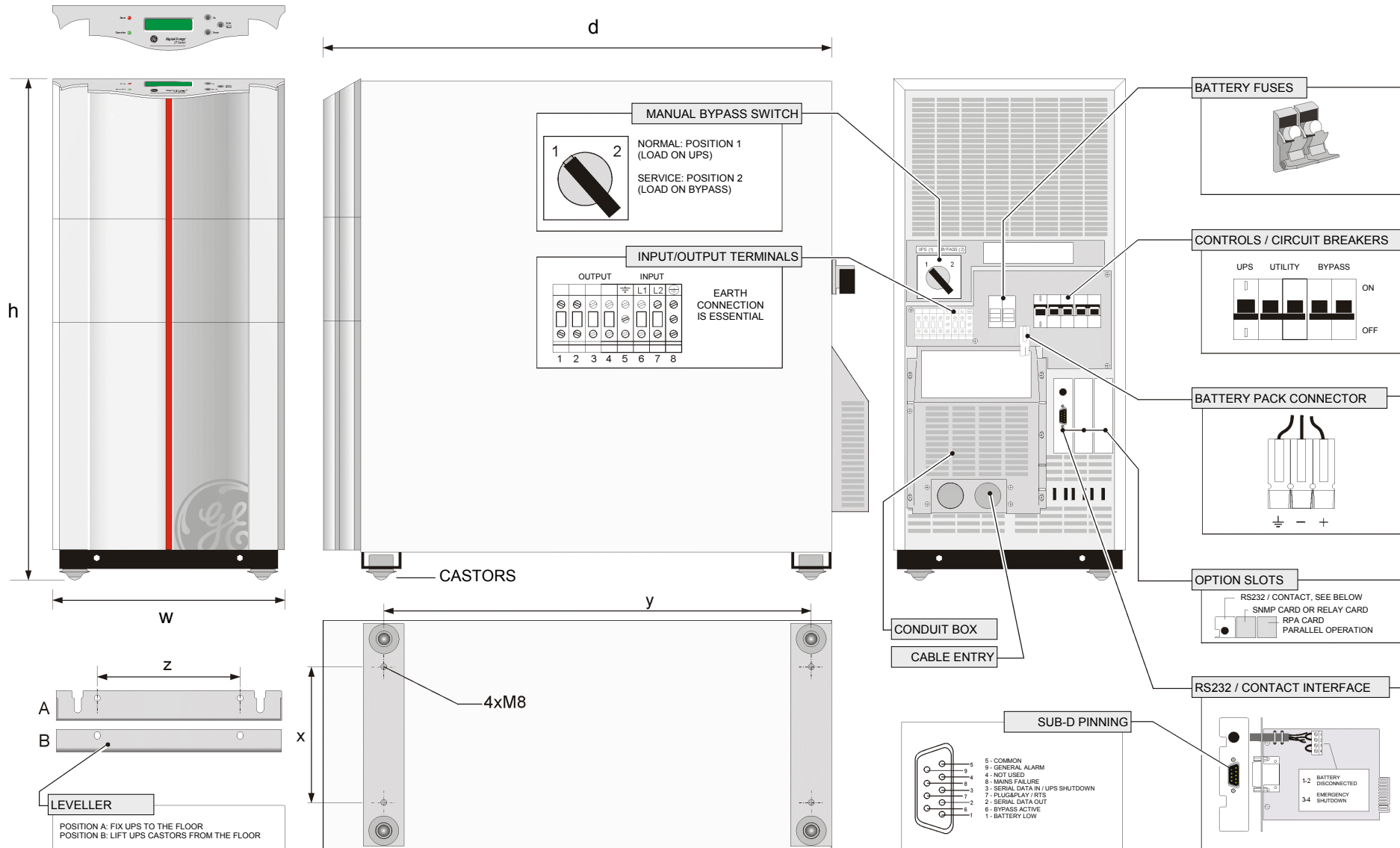



LP 5/6-11U 120V input

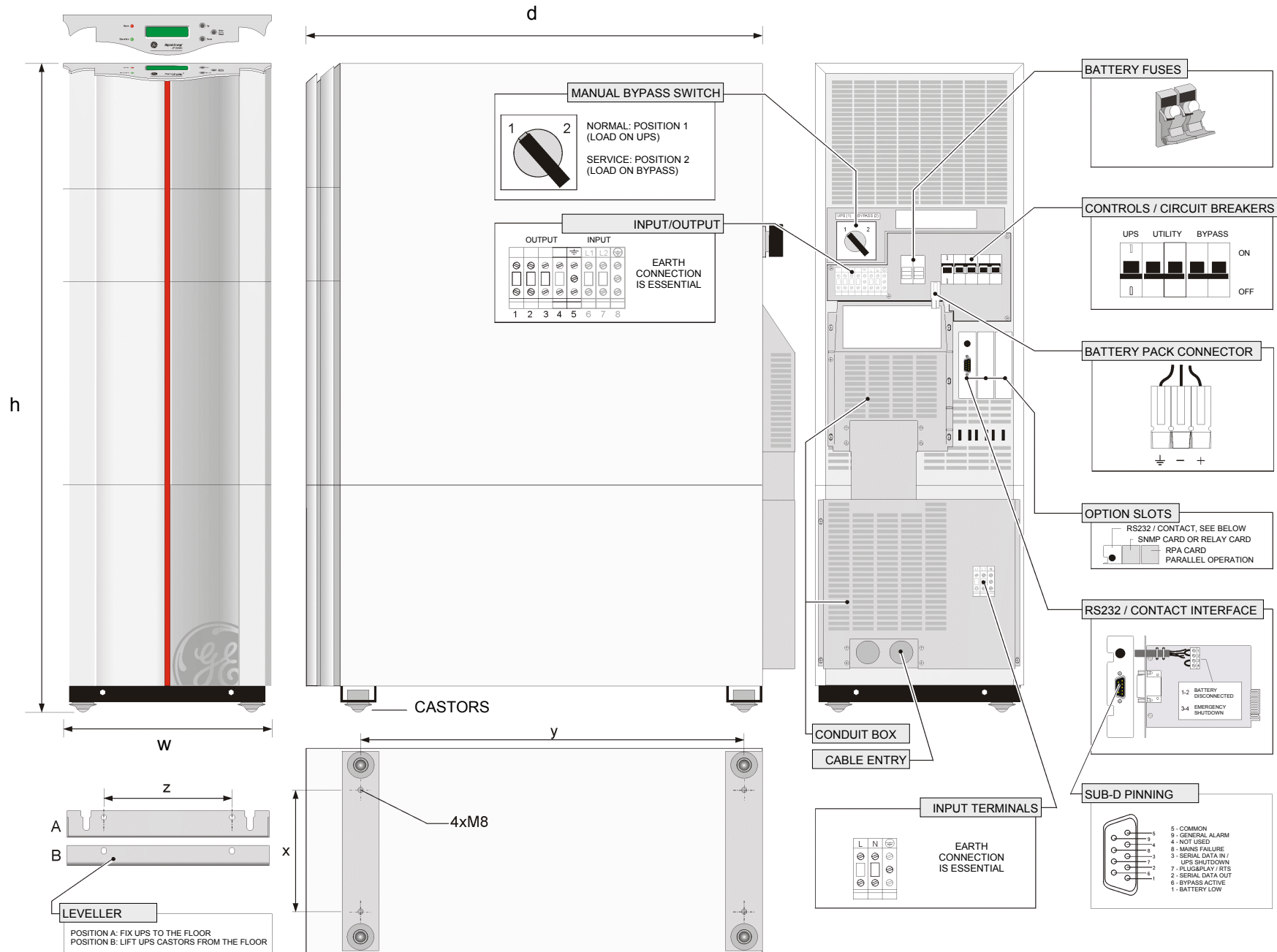

Free Manuals Download Website

<http://myh66.com>

<http://usermanuals.us>

<http://www.somanuals.com>

<http://www.4manuals.cc>

<http://www.manual-lib.com>

<http://www.404manual.com>

<http://www.luxmanual.com>

<http://aubethermostatmanual.com>

Golf course search by state

<http://golfingnear.com>

Email search by domain

<http://emailbydomain.com>

Auto manuals search

<http://auto.somanuals.com>

TV manuals search

<http://tv.somanuals.com>